



AgEcon SEARCH
RESEARCH IN AGRICULTURAL & APPLIED ECONOMICS

The World's Largest Open Access Agricultural & Applied Economics Digital Library

This document is discoverable and free to researchers across the globe due to the work of AgEcon Search.

Help ensure our sustainability.

Give to AgEcon Search

AgEcon Search

<http://ageconsearch.umn.edu>

aesearch@umn.edu

*Papers downloaded from **AgEcon Search** may be used for non-commercial purposes and personal study only. No other use, including posting to another Internet site, is permitted without permission from the copyright owner (not AgEcon Search), or as allowed under the provisions of Fair Use, U.S. Copyright Act, Title 17 U.S.C.*

No endorsement of AgEcon Search or its fundraising activities by the author(s) of the following work or their employer(s) is intended or implied.

HILGARDIA

*A Journal of Agricultural Science Published by
the California Agricultural Experiment Station*

VOLUME 18

JUNE, 1948

NUMBER 6

**SAMPLE MANIPULATION
AND APPARATUS USEFUL IN ESTIMATING
SURFACE AND PENETRATION RESIDUES
OF DDT IN STUDIES WITH LEAVES
AND FRUITS**

FRANCIS A. GUNTHER

UNIVERSITY OF CALIFORNIA • BERKELEY, CALIFORNIA

CONTENTS

Introduction	297
Materials and methods	298
Leaf studies	299
Fruit studies	301
Analytical procedure for estimating DDT	305
Efficiency of stripping technique for removing surface deposit of DDT	307
Efficiency of technique for removing penetrated DDT	308
Photoelectric arealimeter	309
Summary	315
Acknowledgment	316
Literature cited	316

SAMPLE MANIPULATION AND APPARATUS USEFUL IN ESTIMATING SURFACE AND PENETRATION RESIDUES OF DDT IN STUDIES WITH LEAVES AND FRUITS^{1, 2}

FRANCIS A. GUNTHER³

INTRODUCTION

THE CONSEQUENCES of DDT applied in the field have been intensively investigated at the University of California Citrus Experiment Station since 1943. Early in this investigation certain instances disclosed that DDT, as it was applied in the field in various experimental formulations, actually penetrated the fruit and leaf tissues. This indicated potential consumer hazards. Therefore, a detailed semiquantitative examination of surface residues and of the extent and degree of penetration resulting from such applications was undertaken.

Materials examined in this program included fruit, and sometimes leaves, from mature apple, avocado, citrus, olive, peach, pear, and plum trees. At the present time a report of the analytical techniques developed empirically from the handling of many thousands of these samples, and a detailed description of some of the apparatus used may be of benefit to other investigators.

Carter and Hubanks (1946)⁴ recently presented a brief discussion of apparent "recoveries," by analytical methods, of DDT added to dried plant material, including apples. Their results agree with those obtained by the techniques developed during the present investigation. Moreover, Wichmann *et al.* (1946) recently have thoroughly discussed the application of three methods for the quantitative determination of DDT as spray residues on fresh fruit, particularly apples and pears. Certain points of similarity between the techniques discussed by Wichmann *et al.*, and those discussed in the present paper will be noted.

It must be emphasized that certain of the manipulative procedures described in this report are only semiquantitative in nature. This is particularly

¹ Received for publication July 25, 1947.

² Paper No. 576, University of California Citrus Experiment Station, Riverside, California.

³ Assistant Insect Toxicologist.

⁴ See "Literature Cited" at the end of this paper for complete data on citations, referred to in the text by author and date of publication.

true of the treatments designed for the recovery of penetrated DDT. A careful check of all such semiquantitative procedures indicates 75 to 90 per cent recovery of penetrated DDT. Quantitative recovery data for the most important techniques have been included in the appropriate sections.

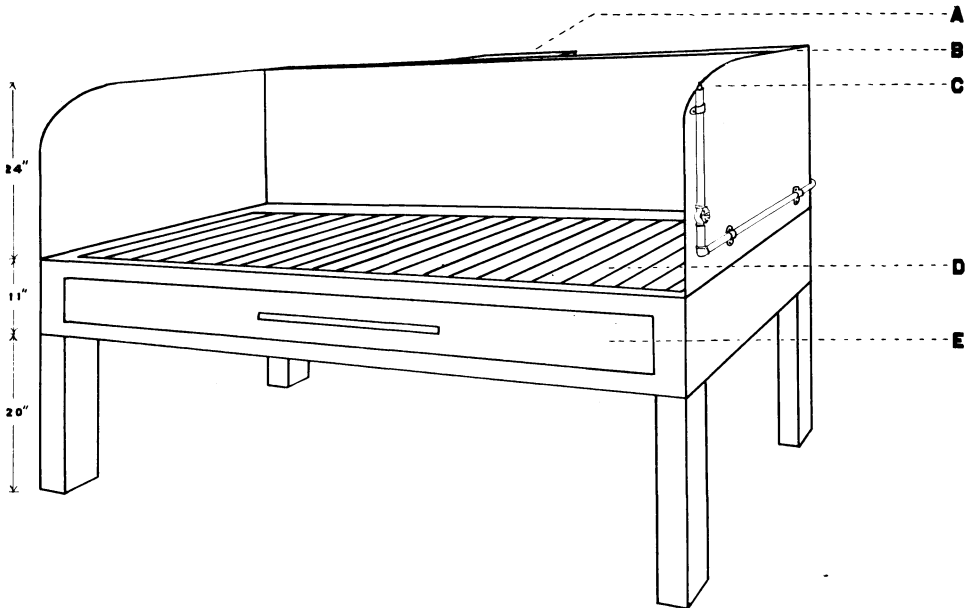

Fig. 1.—Downdraft hood designed especially to handle benzene vapors during stripping operations in DDT surface-residue and penetration studies. *A*, vent; *B*, false back; *C*, compressed-air pipe; *D*, slotted floor; *E*, plenum chamber. None of the dimensions shown is critical, as they were determined by convenience only.

Heavier-than-air vapors are drawn through the slotted floor (*D*) into the plenum chamber (*E*) below, up through the false back (*B*), and are then exhausted out of doors through the vent (*A*). An explosion-proof motor and an efficient fan are mounted in the vent (*A*). The slotted openings in the floor (*D*) of the hood are parallel to the air stream to avoid turbulence foci. A large shallow pan placed on the floor of the plenum chamber (*E*) prevents spilled materials from attacking the plywood flooring. The front panel of this chamber (*E*) is removable to allow easy access for cleaning and for recovering dropped objects. The pipe (*C*) is connected to the laboratory compressed-air supply, and is fitted as shown, with a needle valve and a tubing nipple. A graduated cylinder, thumb-controlled wash bottle (fig. 2) is connected to this nipple by means of a convenient length of rubber tubing threaded through an ordinary screen-door spring. This is to allow for flexibility of manipulation and freedom of interference and yet eliminate danger of collapsing or kinking of the tubing. (Drawing by Miss Athalie Thomas.)

MATERIALS AND METHODS

Penetrated DDT is usually expressed in terms of parts per million by weight. Surface DDT may also be expressed in terms of parts per million, but it is usually best expressed in terms of micrograms of DDT per square centimeter of surface. In the present studies, leaf areas were measured by

means of a photoelectric arealimeter;⁵ fruit surfaces were estimated by means of numerical tables of spheroidal surfaces (Turrell, 1946), in which measurements of the major and minor axes are translated into the areas involved.

The surface residual or the penetrated DDT was removed from the samples by solution in benzene (benzol). Benzene was selected for this purpose because of its high solvent power for DDT (Gunther, 1945*a*), its low cost, its ready availability in large quantities, and its poor solvent power for most inorganic chlorides and for such constituents of fruits and leaves as sugars, many pigments, and many fatty and waxy materials.

Benzene is a very toxic substance, however, and its vapors can be dangerous if inhaled over a long period. Experience has shown that the ordinary updraft hood will not adequately handle the dense benzene vapors. For example, in the fruit-stripping operations described later it quickly became apparent that the normal turbulence at the front of the hood did not provide for sufficient mixing to protect the operator from the benzene vapors. This was true even when the hood window was nearly closed and only the arms of the operator extended into the working space of the hood. One operator became gravely ill after working intermittently under these conditions over a period of a few months. The solution for this problem was a downdraft, slotted-floor hood (fig. 1).⁶

Leaf Studies

Sampling.⁷ Satisfactorily consistent analytical agreement between replicates of field samples of citrus leaves involved the use of two operators. Six trees in the plot were selected at random, the only requirements being that they must not be the trees treated either first or last from the tank of spray or dust material, and that they must not be manifestly atypical trees.

The first tree was circled clockwise by the first operator, and 5 average-sized mature leaves were selected at random from a foot-wide belt at chest height from each quadrant. Ordinarily, leaves from the same cycle of growth were chosen. This was done because of possible unknown effects of the nature of the leaf surface upon initial deposit, subsequent rate of penetration, and rate of weathering. For precise work, the leaves were held with a pair of long specimen forceps while the stem was clipped with a pair of fruit-picking shears. In this way, loss or transfer of deposit by finger contact was avoided. For most routine purposes, however, picking by fingers was done to save time.

The leaves were placed in a wide-mouth 2-quart Mason jar suspended from the neck of the operator by a rope harness. After the tree had been completely circled, the twentieth leaf was picked at the starting point. In this manner, the first operator circled the first, third, and fifth trees, and thereby collected 60 leaves. Meanwhile, the second operator circled counterclockwise the second,

⁵ Apparatus designed and constructed by the writer, with the assistance of C. W. Barnhardt. For details, see figures 3 to 7, with text description.

⁶ Apparatus designed and constructed by the writer, with the assistance of H. U. Meyer and C. R. Shafer.

⁷ Based in part on a statistical analysis of valid sample size and technique of sampling as conducted in connection with another project (A. M. Boyce and J. F. Kagy. Unpublished manuscript, 1939). The double-operator and reverse-circling modifications have proven their worth in helping minimize through randomization the so-called "psychological factors" involved in field sampling of citrus leaves.

fourth, and sixth trees, and similarly collected 60 leaves. At this point the two operators exchanged jars. Trees two, four, and six were then sampled by the first operator with his clockwise circling, and trees one, three, and five by the second operator with his counterclockwise circling.

Through this complicated procedure, a highly desirable divorce from the personal factor was secured in the selection of leaves. Thus, each sample of the 120-leaf duplicate pair was a composite from six random trees, picked in a consistent manner by two operators working always from opposite directions and contributing the same number of equivalent specimens to both samples. Further randomization was obtained by having the operators work alternate trees, then recycle to pick up the skipped trees.

The jar containing these 120 leaves was capped with waxed paper and a Kerr lid assembly. It was then stored in the shade while awaiting transport back to the laboratory. Samples for later use were placed under refrigeration in the laboratory until needed. Most of the leaves studied can be held at 40° F for 2 to 3 weeks before serious decomposition sets in.

Manipulation for Residue Analyses. Exactly 120 average-sized (about 25 square centimeters of single surface area per leaf) mature leaves were collected from the treated trees at the cessation of drip or runoff, as described above. After approximately 24 hours (Gunther *et al.*, 1946), the total surface area of the sample was determined photoelectrically. The leaves were replaced in the jar with 150 ml of benzene, and the jar was capped with a Kerr lid assembly over four layers of waxed paper. The jar was then vigorously shaken manually, 20 times vertically and 20 times horizontally, with rotation; it was then inverted and shaken 20 times more, vertically.⁸ After decantation of the benzene extract through a fluted shark-skin filter paper into a 500-ml standard-taper Erlenmeyer flask, an additional 100 ml of benzene was added and the shaking process repeated. Both extracts were combined and worked up essentially as described previously (Gunther, 1945*b*, 1945*c*). In order to adapt this published procedure to the mass-production problems of the present experiments, however, certain short cuts and techniques were developed. These will be described later.

Manipulation for Penetration Studies. Duplicate samples of 120 average-sized mature leaves were collected, leaf areas were determined photoelectrically, and samples were weighed to the nearest gram. One sample was then stripped with benzene, as described above, to obtain the surface residue. Leaves of the duplicate sample were distributed among four pie tins lined with waxed paper, and were dried at 65° C in a forced-draft oven for 12 hours. These dried leaves were then placed in a small, clean paper bag and crushed manually by kneading. The resulting leaf fragments were transferred to an extraction thimble (60 × 180 mm) and extracted exhaustively with 350 ml of benzene until the extract had run clear for 24 hours. After filtering, this extract was analyzed for its DDT content in accordance with the procedure described in a subsequent section (see "Analytical Procedure for Estimating DDT").

⁸The use of a mechanical stripper is advisable wherever expedient. We now use a 16-compartment drum-type stripper, which turns over at 50 r.p.m., and a stripping period of 30 minutes for standardization. The described manual stripping has proved adequate for replicated field experiments, however.

For precise work, a supplemental check procedure was devised to eliminate the possibility of carrying surface DDT inside the leaf, or vice versa, during the surface-stripping operation. In this procedure the leaves of one sample were subjected to the treatment for total DDT content. The leaves of the duplicate sample, on the other hand, were scrubbed manually on both sides with warm 10 per cent trisodium phosphate solution, rinsed thoroughly with distilled water, and then dried and extracted as described above.

With the first procedure, subtraction of the surface DDT value from the total DDT value gives the penetration value. The supplemental, second procedure serves as a check on stripping carry-in, because the value obtained when the penetration value from the leaves scrubbed with trisodium phosphate is subtracted from the total DDT value should equal the surface value obtained from the first procedure. If it does not, subsequent samples should be treated according to the second procedure, although it is too laborious and time consuming for mass production, and is to be recommended only when extreme precision is required, as in exploratory runs.

Fruit Studies

Sampling. In general, 8 pounds of most fruits constitute an adequate sample. With mature apples, avocados, grapefruit, lemons, oranges, peaches, and pears, an 8-pound sample ordinarily comprises from 10 to 30 fruits. The usual amount of DDT found on this quantity of fruit is well within the optimum range of the dehydrohalogenation method for the quantitative estimation of the DDT. It is also sufficient to minimize the various manipulation losses.

Whenever possible, the fruits were picked at shoulder height, approximately 2 pounds per tree, as widely spaced as possible. They were handled very carefully to minimize mechanical dislodgement of the existing surface deposit of the insecticide. The fruits were then placed in paper bags (nos. 16 to 20), according to fruit size, and the top of each bag was folded down and stapled shut to prevent any possibility of subsequent contamination. Samples to be used for initial surface-deposit or penetration studies were worked up immediately; otherwise, they were placed under refrigeration to await analysis. Most of the fruits studied can be held near 40° F for 2 to 3 weeks without appreciable loss of DDT.

Manipulation for Residue Analyses. Duplicate fruit samples of approximately 8 pounds each were collected and their weights determined to the nearest 10 grams. Where an analytical value of units of DDT per square centimeter was desired (rather than parts per million), it was necessary also to approximate the surface area of the sample by means of Turrell's (1946) tables. In order to do this, the major and minor axes of each fruit were determined with calipers to the nearest one-tenth millimeter. These values sufficed to locate the appropriate surface area for that fruit value in table 1 or table 2 of Turrell's book. The surface areas of fruits approximating in shape oblate or prolate spheroids, or spheres, may be determined readily according to this method.

Among the fruits studied, apples, citrus fruits, peaches, and plums simu-

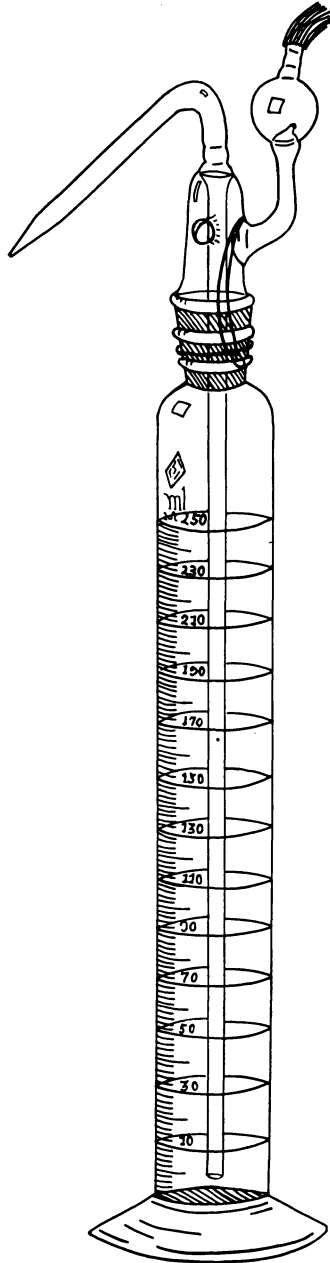

Fig. 2.—Pressurized, thumb-controlled, graduated-cylinder wash bottle used to strip deposits of DDT from fruit surfaces. (Drawing by Miss Rita Ninteman.)

late the regular shapes named above. Avocados and pears, however, present another problem. The areas of such fruits may be roughly approximated by considering each as a truncated cone placed upon a sphere, and calculating accordingly. At the present time, because of the intrinsic uncertainty underlying this geometrical approximation, an analytical value expressed in parts per million is to be considered the more cogent expression. Because of their small size, olives are usually weighed rather than measured.

For the analyses, a 500-ml standard-taper Erlenmeyer flask was fitted with a 6-inch funnel containing a 20-cm fluted shark-skin filter paper and placed on the floor of the downdraft hood. Each fruit was then pierced with an ice pick, held over the funnel, and rotated slowly. A fine stream of benzene was played over the surface of the rotating fruit by means of the pressurized, thumb-controlled, graduated-cylinder wash bottle shown in figure 2, until 15 ml of benzene had passed onto the fruit. After the entire sample had been stripped in this manner, an additional 15 ml of benzene was used to wash the filter paper and the stem of the funnel. The strip solution was worked up as described in a subsequent section.

Manipulation for Penetration Studies. Duplicate samples of approximately 8 pounds of fruit each were collected and their weights determined to the nearest 10 grams. Because the porous and thin skins of most fruits are readily permeable to benzene, and thus to a solution of DDT in benzene, it is not practical to strip fruits with benzene to remove surface deposits and then use these same fruits for penetration studies. Each fruit must therefore be scrubbed carefully with warm 10 per cent trisodium phosphate solution and rinsed thoroughly with distilled water. Obviously, the skin type determines the manner in which fruits are to be treated after scrubbing and rinsing. The further preparation of each of the various fruits studied is discussed briefly for purposes of illustration.

With all of these fruits it is well to compare yields of DDT from the steeping technique with those from exhaustive extraction, to determine the extent of DDT retention by the former more practicable method. In general, from 93 to 96 per cent of the DDT present in the dried material is transferred to the solvent with one steeping operation based upon the original excessive volume of benzene added. For example, if 500 ml of benzene is added to the dried sample, and, after steeping and gravity filtering, 200 ml of benzene is recovered, then the final DDT value obtained upon analysis is actually only about 40 per cent of the true value that would have been obtained had there been no retention of solvent in the marc.

Apples and Pears. Each fruit was cored with a standard mechanical apple corer. It was then skinned carefully with a Nee-Action Peeler^o whose left cutting blade had been sharpened to a razor edge and cutting slit widened to 5 mm. This type of peeling device removes a minimum of flesh when narrow strips (about 0.5 inch) of peel are removed. The strips of peel and the flesh of the fruit were then forced separately through a sausage grinder equipped with 0.18-inch perforations in the pulverizing plate. After being placed in pie tins lined with waxed paper, the ground peel and ground flesh were dried at 65° C in a forced-draft oven for 16 to 20 hours, then steeped separately with

^o M. and M. Mfg. Co., Chicago, Ill.

sufficient benzene to cover for 48 hours. The resulting extracts were filtered and worked up, as described in a following section, to yield values for peel content of DDT and flesh-penetrated DDT.

If the fruit is ripe, the grinding process results in a thin soup which is very difficult to dry satisfactorily, even in a vacuum oven. Ripe fruits were therefore cut into 0.125-inch slices, which were stacked carefully in the pie tins to allow circulation of air through the stack. They were then dried as above, but for 32 hours. The dried slices were triturated with benzene and then steeped for at least 48 hours.

Avocados. The thin-skinned varieties of avocado received the same treatment as apples and pears. The thick-skinned varieties were cut in half and the flesh scraped out as completely as possible with a tablespoon having one edge sharpened. Flesh and peel were then treated in the usual manner.

Citrus Varieties. The fruits were halved and each half was then reamed on a power juicer. Shreds of pulp still adhering to the inside of the hemisphere of peel were scraped out with the aid of a sharpened tablespoon. After the peel was diced, it was dried at 65° C for 16 to 20 hours in a forced-draft oven; it was then crushed and steeped with benzene in the usual manner.

Because the skin of a citrus fruit consists of two distinct portions, namely, the outer layer (flavedo) containing the oil glands and the inner spongy layer (albedo), the course of penetration of DDT into these layers was interesting to trace. For these studies, the peel was removed from lemons and oranges in longitudinal segments not more than 1 inch wide at the equatorial band. This was done with a special buttonhook-shaped peeler. Such a segment was then held flat upon a wooden block and the albedo was neatly severed from the flavedo with a Nee-Action Peeler. After a little practice, two or three strokes with the peeler usually sufficed to separate the two layers almost quantitatively. The albedo and flavedo were subsequently dried separately and extracted in the usual manner.

When semiquantitative studies of the juice and pulp were also to be made, the carefully peeled fruits were placed in a strong canvas bag and squeezed in a wine press until most of the juice had been expressed. The pulp so obtained was triturated with a little water and filtered on a Buchner funnel with the aid of a rubber dam made from a piece of inner tube. The filter cake was then dried and extracted in the usual manner. After the above filtrate had been added to the expressed juice, the resulting mixture was extracted with ether or petroleum ether (30° to 60° C). (Benzene could not be used because it formed too tight an emulsion with the juice.) The brown oil left after removal of the ether under reduced pressure was then triturated with 100 ml of benzene. After standing for several hours in the refrigerator, the benzene layer was decanted and the residue again extracted with 100 ml of benzene. The combined benzene extracts were worked up in the usual manner.

As an alternative procedure for juice and pulp analysis—when the sample was small enough—the peeled fruits were pulped with 100 ml of water in a Waring Blender. After filtration with suction, the filter cake was repulped with another 100 ml of water and refiltered. The pulp and combined juice filtrates were then extracted as described above.

Olives. These fruits were washed thoroughly with warm 10 per cent trisodium phosphate solution to remove surface DDT, rinsed, pitted with a no. 4 cork borer, and pulped in the sausage grinder. Most of the oil was expressed from the resulting pulp in a hydraulic press at 20,000 pounds per square inch. The remainder of the oil was removed by two triturations of the press cake with petroleum ether, followed by suction filtration with the aid of a rubber dam. The filter cake was worked up in the usual manner. The expressed oil was combined with the petroleum ether filtrates, and the solvent was removed under reduced pressure. A threefold volume of benzene was added to the residual oil with vigorous agitation, and the oil was then frozen out of the mixture in the freezing compartment of the refrigerator. After decantation of the oil, the mush of frozen benzene was allowed to warm to room temperature, then was treated in the usual manner.

Peaches. After a thorough scrubbing with 10 per cent trisodium phosphate solution, the rinsed peaches were immersed in boiling water for about 1 minute, whereupon the skins were easily lifted off. The skins and flesh were then worked up separately in the usual manner. The brief immersion in boiling water apparently had little effect upon any DDT present.

Plums. No really satisfactory method for the preparation of plum samples has been devised. The stringy nature of the flesh and the high water content of the fruit have been the detrimental factors. The best and most consistent results with plums were obtained by the same treatment given to peeled citrus fruits. Vacuum drying and lyophilization were not tried, although either would probably dry the plums satisfactorily.

Analytical Procedure for Estimating DDT

The following procedure was evolved as that most satisfactory for mass DDT analyses. It is based upon the quantitative dehydrohalogenation of DDT (Gunther, 1945*b*, 1945*c*). However, since many minor modifications have been introduced to circumvent certain deficiencies encountered in the processing of many thousands of surface and penetration samples, the entire modified procedure is presented here.

Evaporation. The benzene strip or extract solutions, in 500-ml standard-taper Erlenmeyer flasks, are evaporated nearly to dryness, three at a time, on the left three units of a six-unit variable-heat extraction-apparatus hot plate. By means of an adjustable glass-tube assembly, a jet of air is caused to impinge upon the surface of the benzene solution. The heating element and the jet of air are so balanced that the evaporating benzene solution does not exceed 50° C, yet the jet of air is sufficiently gentle to prevent spattering when maintained 0.5 inch above the surface of the liquid. As the benzene evaporates, the inlet for the jet of air is lowered from time to time. This is done to maintain, approximately, the half-inch gap between it and the surface of the liquid. Across the back of the heater assembly is placed a manifold which is connected with the laboratory vacuum system. Into this is fed the emergent vapors from the evaporators. Ordinarily, on this apparatus 250 ml of sample can be reduced to a volume of about 5 ml in 10 minutes.

Digestion. To the moist residuum from the evaporation is added approximately 50 ml of 1 *N* ethanolic potassium hydroxide solution from a graduated cylinder. The flask is then placed on one of the three hot plates on the right side of the apparatus. It is fitted with a reflux condenser, and allowed to reflux gently for exactly 15 minutes, as timed by a stop clock. Three digestions may be carried on simultaneously; in the meantime fresh samples are placed on the evaporators. At the expiration of 15 minutes, the digestion flask is disconnected from its condenser, and 100 ml of distilled water is added rapidly from an automatic Machlett pipette, in order to stop the reaction. Two drops of phenolphthalein indicator solution are then added, followed by 50 ml of 2 *N* nitric acid solution from another automatic pipette. If the phenolphthalein still imparts a pink color to the solution, a few more drops of the acid solution are added. Exactly 25 ml of a saturated solution of c.p. barium nitrate is then added, with swirling, to precipitate as their barium salts any fatty acids resulting from saponification.

Propionic and butyric acids are not completely precipitated by this treatment. Where these acids appear as saponification products of the natural fats and waxes in the original strips or extracts, an alternative procedure has been developed (Beier *et al.*, 1946).

After standing at room temperature for 5 minutes or longer to allow some coagulation of the precipitated barium salt, the flask contents are filtered with gentle suction through a fluted shark-skin filter on a Fisher Filtrator into a 400-ml beaker. In order to remove water-soluble chlorides present in the paper, it is imperative that the filter paper be washed thoroughly with distilled water prior to the filtering operation. A battery of four such filters has been found most convenient for maximum efficiency.

Titration. Two drops of concentrated sulfuric acid are added to the beaker of clear or faintly turbid filtrate. The beaker is clamped into position on a warmed-up Leitz G. and D. Electro-Titrator,¹⁰ and the stirrer is started. From an automatic microburette graduated in hundredths of a milliliter, approximately 1 ml of 0.05 *N* sodium chloride is added to the sample to insure a strongly positive titrator response, even if the sample originally contained no DDT. The sensitivity knob of the Electro-Titrator is turned to 7.0, the electrode switch is turned to position 2, and the zero adjustor knob is turned until the indicating needle reads 10.0; the control knob for battery is maintained in the far counterclockwise position throughout. Then 0.05 *N* silver nitrate solution is added rapidly from another automatic microburette until the indicating needle reaches 5.9. At this point, dropwise addition of the silver nitrate is started and continued until the needle reads about 3.6, whereupon fractional drops are added to the end point 2.9.

This end point of 2.9 incorporates all corrections due to unknown factors present in all of the reagents and reactions in the entire analytical procedure. Actually, this end-point value will vary with the composition of the wet electrode, which in this instance is a calomel type containing a saturated solution of mercurous sulfate in 0.1 *N* sulfuric acid solution layered over mercury. The other electrode is silver on platinum.

From the two burette readings, the milligrams of DDT originally present

¹⁰ Gamma Instrument Company, 95 Madison Avenue, New York, N.Y.

in the sample may be calculated as follows, assuming that one mole of DDT liberates exactly one mole of chloride ion:

$$[(\text{ml AgNO}_3) (N)] - [(\text{ml NaCl}) (N)] 354.5 = \text{mg DDT}$$

If a blank value for the parent fruit or leaf sample exists, it must be subtracted from the above value to obtain the net milligrams of DDT originally in the sample.

The assumption that one mole of DDT liberates exactly one mole of chloride ion is valid only when *c.p. p,p'*-DDT (m.p. 108° C or higher) is involved. Under the conditions specified, technical DDT of setting point around 90° C will ordinarily liberate 1.145 moles of chloride ion per mole of parent mixture. Presumably, this discrepancy is traceable to the abnormal hydrolysis of some of the *o,p'*-isomer present to yield the chlorophenylated acetic acid derivative in addition to the desired ethylene.

EFFICIENCY OF STRIPPING TECHNIQUE FOR REMOVING SURFACE DEPOSIT OF DDT

Several samples of 120 orange leaves each from field applications of DDT were treated and stripped in the usual manner. They were then restripped. Analyses of the two separate strip solutions yielded the values shown in table 1.

TABLE 1
DDT ANALYSES OF SUCCESSIVE STRIP SOLUTIONS FROM
FIELD-TREATED SAMPLES OF ORANGE LEAVES

Sample		DDT in solution, Mg*/cm ²	
Code number	Total area, cm ²	First stripping	Second stripping
2A	5,267	1.6	0.0
3A	5,673	1.9	0.0
4B	5,301	5.8	0.0
6A	5,078	6.4	0.0
9B	5,172	8.6	0.0
8B	5,105	9.0	0.1
19B	4,516	13.3	0.2
7A	5,795	15.1	0.2

* Micrograms.

The data show that the larger the deposit of DDT, the less efficient its removal in the first stripping operation. When untreated leaves were placed in jars with added quantities (2 to 20 mg) of accurately weighed *c.p.* DDT (m.p. 108° C) and then stripped, recoveries of DDT by analysis varied from 98 to 101 per cent.

Mature apples, grapefruit, lemons, oranges, and pears that had been sprayed or dusted in the field with various preparations containing DDT were stripped by the wash-bottle technique and then restripped a few minutes later into separate receivers. With few exceptions, the second stripping showed no determinable DDT for these fruits (table 2).

TABLE 2
DDT ANALYSES OF SUCCESSIVE STRIP SOLUTIONS FROM FIELD-TREATED
SAMPLES OF VARIOUS FRUITS

Sample				DDT in solution			
Fruit	Code number	Total area, cm ²	Total weight, grams	First stripping		Second stripping	
				Micrograms per square centimeter	Parts per million	Micrograms per square centimeter	Parts per million
Grapefruit	2A	1,263	2.5	...	0.0	...
	2B	1,243	2.5	...	0.0	...
	27A	1,309	7.8	...	0.0	...
	27B	1,271	7.7	...	0.1	...
Lemons	LA	4,338	1.0	...	0.0	...
	LB	7,598	1.0	...	0.0	...
	KA	4,177	4.5	...	0.0	...
	KB	4,130	4.6	...	0.0	...
Valencia oranges	LA	4,780	2.4	...	0.0	...
	LB	4,738	2.5	...	0.0	...
	DA	5,253	9.2	...	0.0	...
	DB	4,974	9.0	...	0.0	...
Apples	H3A	3,888	...	3.7	...	0.0
	H3B	4,114	...	3.7	...	0.0
	C2A	3,606	...	11.9	...	0.0
	C2B	3,434	...	11.8	...	0.0
Pears	A2	7,406	...	6.2	...	0.1
	A3	7,264	...	6.3	...	0.1
	BH1	3,916	...	12.6	...	0.1
	BH3	3,887	...	12.9	...	0.2

EFFICIENCY OF TECHNIQUE FOR REMOVING PENETRATED DDT

In routine fruit analyses the efficiency of removal of penetrated DDT by means of the steeping operation was determined by exhaustively extracting one or two replicates of a steeped sample. Necessary corrections were then

TABLE 3
EFFICIENCY OF TECHNIQUE FOR REMOVING PENETRATED DDT, AS SHOWN BY ANALYSES OF
EXTRACTS CONTAINING KNOWN AMOUNTS OF C.P. DDT ADDED TO OTHERWISE
UNTREATED LEAF AND FRUIT SAMPLES

Sample			DDT		
Type	Code number	Weight, grams	Added amount, milligrams	Recovered amount	
				Milligrams	Per cent
Valencia orange leaves	1	123.5	217.3	207.4	95.4
	2	110.0	80.0	76.1	95.1
Valencia orange fruits	P5	450.0	128.6	123.2	95.8
	P3	450.0	78.2	72.8	93.1
	P1	450.0	28.6	26.9	94.0
Pears	C1	1,008.0	34.8	33.2	95.4
	C2	1,245.0	100.0	95.3	95.3

applied to subsequent steeped samples, for exhaustive extraction of large numbers of samples was not ordinarily feasible. Leaf samples, however, were always extracted exhaustively.

Table 3 shows the results of some studies to determine the efficiency of the removal of added c.p. DDT (m.p. 108° C) from otherwise untreated samples of various leaves and fruits. All samples were prepared in the usual manner, except that before the drying operation the known amount of DDT was added as a saturated acetone solution and mixed thoroughly into the sample. After the acetone had evaporated at room temperature, the usual routine treatment followed. With the leaf samples, no corrections were applied, as they were always extracted exhaustively. Fruit samples were steeped with a known volume of benzene, the volume of filtrate was measured, and the correction necessary to convert to original volume was applied.

PHOTOELECTRIC AREALIMETER

The literature of this field occasionally refers to photoelectric apparatus of one type or another, used in measuring the surface areas of irregular planar objects by means of superimposing black images of those objects on the surface of a photoelectric cell. A patient search of the literature is discouraged, however, by lack of uniformity in cataloging either these devices or the papers discussing them, in the various abstract indices. For example, one such instrument may be indexed under "area," another under "meter," another under "photoelectric," or "surface," or "surface measurement." Accordingly, it is suggested that the name "photoelectric arealimeter" be adopted for all instruments conforming to the definition suggested above. This name has not been used before in this or in any other connection, so far as can be ascertained.

Many projects in this laboratory necessitated accurate and expeditious determination of the total surface areas of thousands of leaves of citrus and of other fruits. For one reason or another, no method or instrument either mentioned in the literature or available commercially appeared adequate to this task. The planimeter, for example, was much too slow, and the method of superimposing leaves on shadowgrams of known areas¹¹ was not sufficiently accurate when slight variations in area were involved. An application of the photoelectric cell seemed the best solution to the problem.

Mention of the application of the photoelectric cell to similar problems may be found in the literature (Bulger, 1935; Kramer, 1937; Milthorpe, 1942; and others). Turrell and Waldbauer (1935) have published a bibliography on the use of photoelectric cells in plant investigations. In addition, a few photoelectric arealimeters are available commercially. All these devices were too complicated, too expensive, or insufficiently versatile.

Probably the most rigorous of our requirements was that the arealimeter must not be affected by the normal 30-volt fluctuation in our line voltage at the laboratory wall outlets. Other requirements were that the device should compensate for all green light transmitted by thin or chlorotic leaves, and that it should be completely independent of external current supply for short

¹¹ Ebeling, Walter. Unpublished data on file at the University of California Citrus Experiment Station.

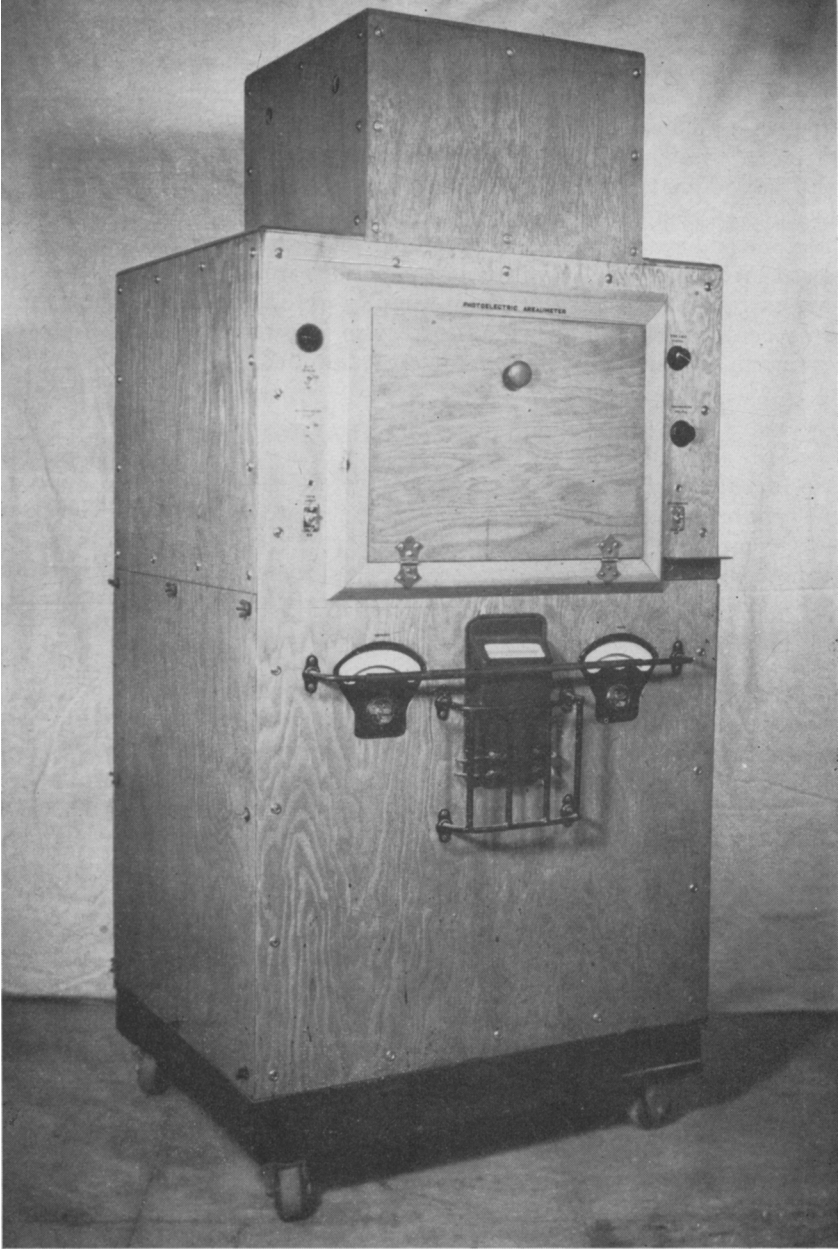

Fig. 3.—Photoelectric arealimeter.

periods of time, so that it could be transported to the field and used there when necessary. And, above all, the arealimeter had to maintain a consistently high accuracy.

All these requirements were met by the photoelectric arealimeter described herein. Free use has been made of suggestions and criticisms found in the works of the authors cited. Certain inherent "kinks" found in those units that are available commercially were carefully minimized in the present arealimeter; the nature of the improvements will become apparent as the reader considers the following descriptions.

Wiring System. A diagram of the complete wiring system of the arealimeter is shown in figure 4. This diagram is self-explanatory, except for the speci-

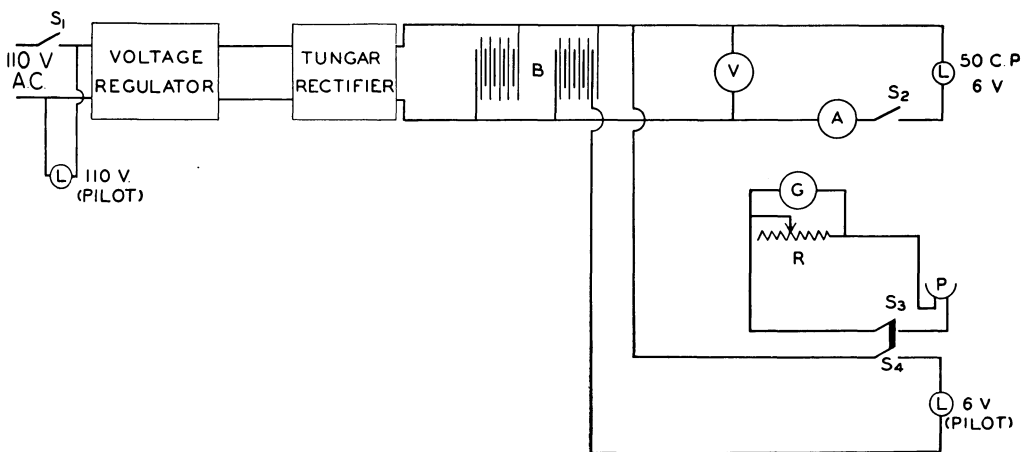

Fig. 4.—Wiring diagram of arealimeter. For description, see the text.

cations of the various instruments used. *L*, in every instance, is a light whose voltage is specified in the figure. The 50-candle-power, 6-volt light is an unfrosted automobile headlight bulb. *B* signifies two 15-plate automobile storage batteries connected in parallel. When the instrument is in continuous operation for long periods the use of four such batteries is advisable in order to decrease the frequency of supplemental recharging. *V* is a panel D.C. voltmeter, and *A* is a panel D.C. ammeter. *G* is a single-reflection, mirror-type galvanometer recalibrated from 0 to 100 in evenly spaced units, with a sensitivity of 0.06 microamperes per scale division and with a critical damping resistance of 1,000 ohms. It was necessary to rebuild the mirror suspensions and relocate the magnet of this galvanometer so that it would work satisfactorily in the vertical position required. *P* is a Weston model 594 G.B. photocell of approximately 3.5 microamperes per foot-candle, type 3S-1459M. *R* is a 500-ohm variable resistance. In addition (not shown in the diagram), a 1-ohm variable resistance is series-connected in the 50-candle-power lamp circuit in order to compensate for the slow aging of that lamp. *S*₁ and *S*₂ are single-pole, single-throw, radio-panel toggle switches, while *S*₃ and *S*₄ comprise a double-pole, single-throw switch.

Lens System. The lens system of the arealimeter is shown in figure 5. The distance between the tip of the lamp and the measuring disk of plate glass is 15 inches, and the top surface of the photocell is 20.5 inches below this plate glass. The measuring disk is 12 inches in diameter. Other pertinent dimensions

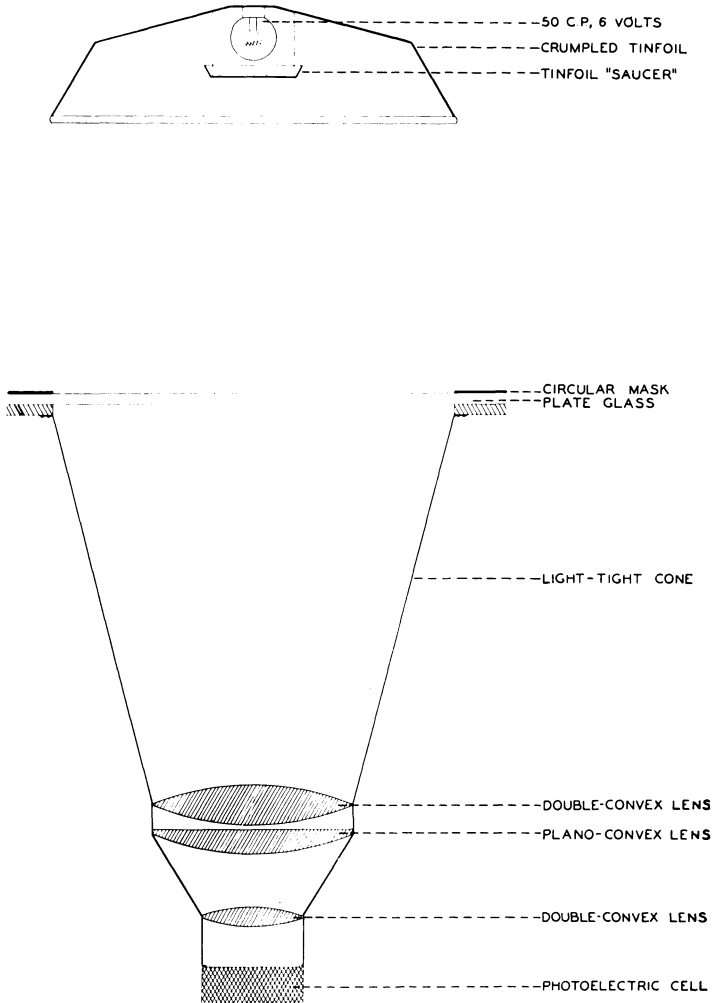

Fig. 5.—Lens system of arealimeter. For description, see the text.

are as follows : diameter of tin foil "saucer," 3 inches; distance from measuring disk to upper prism, 24.5 inches ; diameter of two large lenses, 6 inches each ; and diameter of small lens, 2 inches. These lenses were experimentally spaced to give the sharpest possible image of the entire 12-inch measuring disk over the entire surface of the photocell. A piece of red cellophane stretched tightly across the surface of the photocell satisfactorily excludes the green light transmitted by thin or chlorotic leaves.

Since maximum sharpness of image—and thus maximum accuracy of the instrument—depends on parallel rays of light falling on the measuring disk, the reflector indicated in figure 5 (see also fig. 6) was chosen carefully to fulfill this purpose. A large (12-inch) lens would serve equally well, but was too expensive. To eliminate undesirable highlights from the reflecting surface, and to enhance the uniformity of the light falling upon the measuring disk, the reflector is lined with crumpled tin foil. A 3-inch tin-foil saucer with upturned rim is suspended an experimentally determined distance below the bulb to exclude all direct illumination from the measuring disk. Painting the

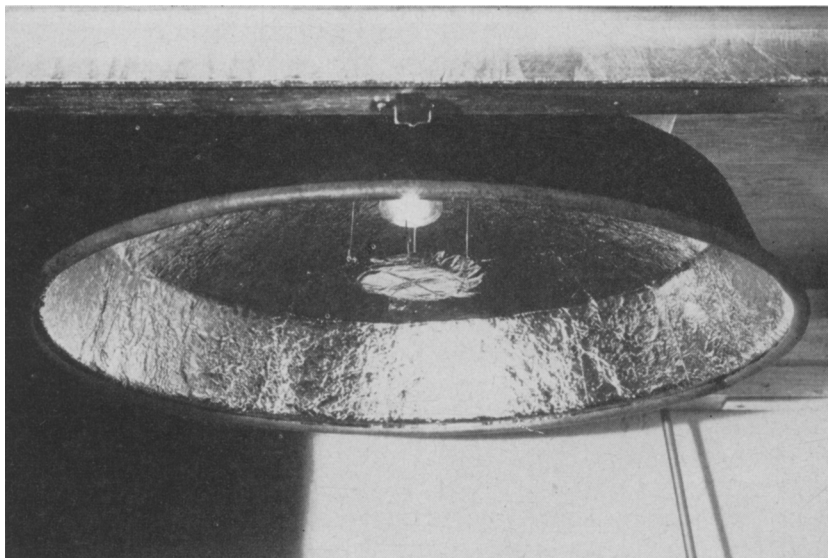

Fig. 6.—Dome-light reflector assembly of arealimeter. Attention is directed particularly to the reflecting surface of crumpled tin foil, and to the suspended "saucer," which effectively eliminates the bright spot caused by direct illumination of the measuring disk.

lower half of the bulb serves the same purposes, but the intensity of light at the measuring disk is thereby decreased materially.

Measuring Plate. The plate on which are placed all objects to be measured is shown in figure 7. The measuring disk is masked with a piece of green desk blotter beneath the plate of glass. The hinged screen, held in upright position by means of two screen-door springs (visible in the background of fig. 7), is used to hold the leaves flat on the surface of the measuring disk. A piece of rubber tubing is fitted around the rim of the reflector to prevent the screen from jarring the light assembly when released to the upright position.

Cabinet. The cabinet (fig. 3), which is built upon a welded base of quarter-inch angle iron in the form of a rectangle 20 inches long by 14 inches wide, is constructed of a well-braced framework of 2 × 2-inch boards faced with quarter-inch 3-ply veneer. A 3-inch rubber-tired steel caster is fastened to each corner of the base to make the arealimeter less difficult to move from place to place. In outside dimensions the cabinet is 51 inches high, 30.5 inches wide, and 24.5 inches deep.

Other features of construction may be discerned readily from the various photographs already discussed. The inside surface of the measuring chamber is given three coats of aluminum paint.

Occasionally it is desirable to measure leaves after they have been stripped rather than before. Most organic solvents will, under the conditions described herein, remove sufficient cuticular and other leaf waxes so that the leaves will begin to curl within a few minutes after stripping. Such leaves must be measured, therefore, while they are still wet with solvent. To alleviate the ill effects from breathing the organic solvents—and especially benzene—in such

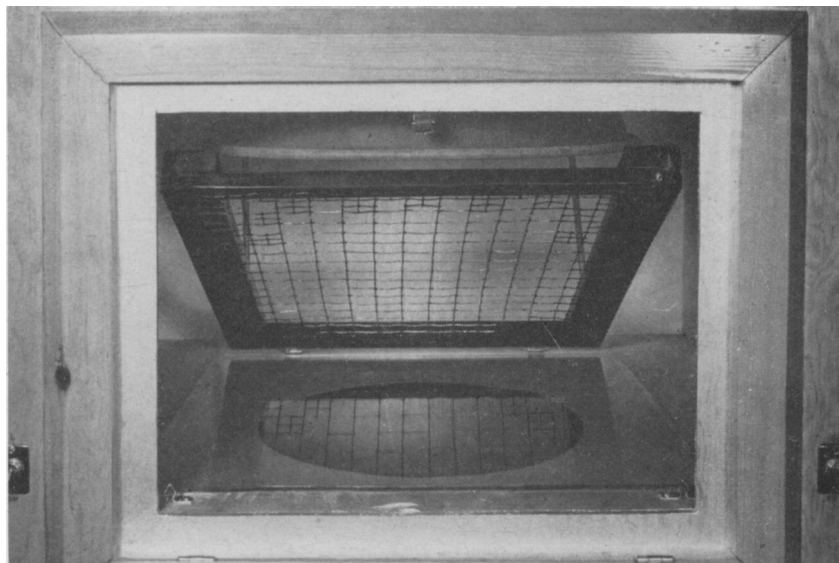

Fig. 7.—Measuring plate of arealimeter, with screen up, showing 12-inch circular measuring disk. Photographed before installation of the pilot lights.

a confined space as the measuring chamber, a 3-inch vibration-free squirrel-cage exhaust fan is mounted at the rear of the dome-light chamber. It is exhausted outdoors. The resulting gentle draft of air through the measuring chamber and away from the operator suffices as protection against the obnoxious vapors arising from the stripped leaves. Since this type of fan will starve itself in a confined space, there is no sudden onrush of air with consequent disturbance of leaves when the cabinet door is opened and closed.

Operation. To allow sufficient warm-up time, all switches (fig. 4) are turned on approximately 30 minutes before use. The galvanometer switch S_3 - S_4 is then turned off and the wire-tension control on the galvanometer housing is adjusted until the galvanometer reads 100. Switch S_3 - S_4 is turned on again, and the dome-light rheostat is adjusted until the galvanometer reads approximately zero; the final zero setting is accomplished with the 500-ohm galvanometer rheostat.

A piece of paper toweling is placed inside the light chamber to the left of the measuring disk, and the sample of leaves is dumped thereon. After the

screen has been raised, approximately 25 leaves are placed more or less haphazardly on the measuring disk. The screen is lowered and clamped, and overlapping, twisted, curled, or wrinkled leaves are straightened through the spacings in the screen. The cabinet door is then closed, and the reading of the galvanometer is noted. The screen is immediately released, the leaves are scraped to the right-hand side of the chamber onto another piece of paper toweling, and a fresh set of leaves is placed in position.

When the entire sample has thus been measured, the leaves are returned to the sample jar to be stripped, the measuring disk is wiped with one of the pieces of paper toweling, and both pieces of toweling are placed in the jar with the sample. The toweling itself contributes nothing to the subsequent DDT analyses, and it serves admirably to pick up any particles of DDT which may have been dislodged by this handling.

Addition of the galvanometer readings for the various sets within a sample, and multiplication of this sum by the constant 13.54, gives the total surface area of the sample in square centimeters. This constant was obtained as follows: Rectangular pieces of green desk blotter were cut as exact multiples of a square centimeter. These were placed in various combinations and in various places on the measuring disk, and the galvanometer reading was noted each time. A plot of galvanometer reading versus area yielded essentially a straight line within the range 0 to 730 square centimeters (full coverage of the measuring disk), whose slope was 6.77. Multiplication of a galvanometer reading by 6.77 therefore gives the single-surface area. In order to obtain the total double-surface area, this slope value is doubled. Other instruments, even though constructed as directed, would require individual calibration as above because of normal variations in photocell response.

With ordinary usage, the battery charger is left on an additional 2 hours for every hour that the arealimeter is in use. An exact balance is not possible because of the drain of the auxiliary pilot lamps, of the galvanometer lamp, and of line losses. As mentioned previously, it is not necessary for the charger to be on while the instrument is in use, if portability is desired. Under these circumstances, the batteries should be recharged for 3 hours to compensate for 1 hour of discharge. The principal reason for having the batteries in the circuit, however, is that they act as "floaters" and absorb all current fluctuations that get by the voltage regulator and the rectifier. Smooth operation of the arealimeter without these batteries is hardly possible.

SUMMARY

Because DDT applied in the field is known to penetrate certain leaves and fruits, empirical techniques for studying the magnitudes of both penetration and surface residues have been evolved and applied successfully since early 1943. The fruits considered in the present report include apples, pears, avocados, citrus varieties, olives, peaches, and plums. General techniques for the sampling and manipulation of leaves, and specific techniques for the sampling and manipulation of the various fruits, are discussed in detail.

Estimations of the DDT in or on the leaves or fruits were made with the aid of the dehydrohalogenation method of analysis, modified for efficient mass

production consistent with reasonable sensitivity. The major modification in this connection was the adoption of an electrometric titration for the chloride ion liberated from the DDT.

A detailed description is also given of the design and operation of a photoelectric arealimeter for the measurement of surface areas of irregular planar objects such as leaves.

ACKNOWLEDGMENT

The writer is indebted to those persons specifically mentioned in the text, and also to the Misses Phyllis Blair, Norma Cassina, Marjorie Elliot, Celia Lesley, Betty McFarland, Pauline Taylor, and Athalie Thomas for their aid in certain phases of the present investigation.

LITERATURE CITED

- BEIER, W. E., E. J. EDMONDS, C. W. WILSON, M. I. ELLIOT, and F. A. GUNTHER.
1946. A method for the quantitative estimation of DDT in plant and/or sulfur-containing materials. *Science* 104:376-77.
- BULGER, J. W.
1935. A photoelectric method for measuring small leaf areas. *Jour. Econ. Ent.* 28:76-81.
- CARTER, R. H., and P. E. HUBANKS.
1946. Determination of DDT deposits on fruits, vegetables, and vegetation. *Assoc. Off. Agr. Chem. Jour.* 29:112-14.
- GUNTHER, F. A.
1945a. Dichlorodiphenyltrichloroethane. I. Solubility in various solvents. *Amer. Chem. Soc. Jour.* 67:189-90.
1945b. Quantitative estimation of DDT and of DDT spray or dust deposits. *Indus. and Engin. Chem., Analyt. Ed.* 17:149-50.
1945c. Aspects of the chemistry of DDT. *Jour. Chem. Ed.* 22:238-42. *Errata. Ibid.*, p. 279.
- GUNTHER, F. A., D. L. LINDGREN, M. I. ELLIOT, and J. P. LADUE.
1946. Persistence of certain DDT deposits under field conditions. *Jour. Econ. Ent.* 39:624-27.
- KRAMER, P. J.
1937. An improved photoelectric apparatus for measuring leaf areas. *Amer. Jour. Bot.* 24:375-76.
- MILTHORPE, F. L.
1942. A simplified photoelectric cell method for measuring leaf areas. *Australian Inst. Agr. Sci. Jour.* 8:27.
- TURRELL, F. M.
1946. Tables of surfaces and volumes of spheres and of prolate and oblate spheroids, and spheroidal coefficients. 153 p. University of California Press, Berkeley and Los Angeles.
- TURRELL, F. M., and L. WALDBAUER.
1935. A bibliography on the use of photoelectric cells in plant investigations. *Iowa Acad. Sci. Proc.* 42:67-70.
- WICHMANN, H. J., W. I. PATTERSON, P. A. CLIFFORD, A. K. KLEIN, and H. V. CLABORN.
1946. The determination of DDT as spray residue on fresh fruit. *Assoc. Off. Agr. Chem. Jour.* 29:188-218.

The journal *Hilgardia* is published at irregular intervals, in volumes of about 600 pages. The number of issues per volume varies.

Subscriptions are not sold. The periodical is sent as published only to libraries or to institutions in foreign countries having publications to offer in exchange.

You may obtain a single copy of any issue free, as long as the supply lasts; please request by volume and issue number from:

Publications Office
College of Agriculture
Berkeley 4, California

The limit to nonresidents of California is 10 separate issues on a single order. A list of the issues still available will be sent on request.

