



**AgEcon** SEARCH  
RESEARCH IN AGRICULTURAL & APPLIED ECONOMICS

*The World's Largest Open Access Agricultural & Applied Economics Digital Library*

**This document is discoverable and free to researchers across the globe due to the work of AgEcon Search.**

**Help ensure our sustainability.**

Give to AgEcon Search

AgEcon Search

<http://ageconsearch.umn.edu>

[aesearch@umn.edu](mailto:aesearch@umn.edu)

*Papers downloaded from **AgEcon Search** may be used for non-commercial purposes and personal study only. No other use, including posting to another Internet site, is permitted without permission from the copyright owner (not AgEcon Search), or as allowed under the provisions of Fair Use, U.S. Copyright Act, Title 17 U.S.C.*

*No endorsement of AgEcon Search or its fundraising activities by the author(s) of the following work or their employer(s) is intended or implied.*

## Major Crops Water Requirements and Automated Irrigation Scheduling System

Amritpal Kaur , Devershi Pallavi Bhatt , Linesh Raja 

Department of Computer Applications, Manipal University Jaipur, India

### Abstract

Agriculture is a critical factor that impacts a country's economy. The agriculture sector uses 70% of the available fresh water. There are challenges in water management and irrigation scheduling that require resolution. Farmers are using traditional irrigation methods that use a lot of water with low water efficiency. Smart irrigation and farm management technology is crucial to sustainable agriculture, as it saves water and provides farmers with more information about crop water requirements. However, managing irrigation water is a complex task that depends on factors such as soil, weather, and environment. Robust modeling is necessary to accurately estimate the water requirements of a crop. In this we developed a smart irrigation model to automate the irrigation system according to water requirements of crops. To estimate the water requirements of crops a review was done on different crop water requirements and crops features. To develop the automated irrigation system an analysis is done on different irrigation methods, irrigation scheduling and requirements of irrigation scheduling. The proposed system is used to automated irrigation system and real time data is sent to think speak server for regular monitoring. The developed automated irrigation system is working up to expectations and help farmers to control the irrigation and conserve water by avoiding over irrigation.

### Keywords

Internet of Things, water management, IoT, sensors, smart griculture, Irrigation Efficiency.

Kaur, A., Bhatt, D. P. and Raja, L. (2025) "Amajor Crops Water Requirements and Automated Irrigation Scheduling System", *AGRIS on-line Papers in Economics and Informatics*, Vol. 17, No. 1, pp. 41-50. ISSN 1804-1930. DOI 10.7160/aol.2025.170104.

### Introduction

Agriculture uses up to 70% of the world's water resources, making efficient water use crucial for preserving water resources for the future. The traditional irrigation system is widely used by farmers. Surface irrigation, which uses gravity to deliver water to crops, is classified into three main types: border, basin, and furrow systems. The basin system has level, diked areas, while the border system has rectangular, sloping borders. Furrows control flow and prevent flooding by creating channels with water leaking through the walls and bottom of furrows (Saggi and Jain, 2022). Sprinkler irrigation is another method for controlled water distribution, such as rainfall, which can be used for various applications, including industrial, residential, and agricultural. Irrigation sprinklers can be used for various applications, including industrial, residential, and agricultural (Abo-Zahhad, 2023). Drip irrigation is the preferred option, as it is the most effective means of supplying water and nutrients

to crops. The system ensures that every plant receives the necessary nutrients and water precisely and timely to its root zone. This technique can save energy, water, and fertilizer while increasing production. Development of agriculture depends on water, particularly in dry and semi-arid regions. By using information and communication technologies (ICTs) to replace outdated methods with more advanced ones, the Indian economy has undergone a substantial transformation (Kondaveti et al., 2019). Services such as crop management, plant disease prevention, smart water management, IoT agriculture, crop management, crop tracking, and geospatial imagery have been made possible. India is one of the countries with the highest consumption of water for irrigation. Understanding the diverse, complex, and unpredictable agricultural ecosystems through ongoing analysis, measurement, and observation of physical elements and occurrences is crucial to overcoming these challenges. DSS (decision support system) should be used as a tool for farm management, assisting farmers in selecting which areas require irrigation

and how much water is required. To achieve efficient and efficient water usage, agricultural irrigation scheduling is an essential task. Applying the proper amount of water at the correct time is a key component of good irrigation scheduling (Tace et al., 2022). To understand the geographical variations in ET (evapotranspiration), irrigation scheduling improves water use efficiency and concentrates on evapotranspiration estimate techniques. Select irrigation applications, incorporate water quality limitations into scheduling and control models, and combine many sensor technologies (Dari et al., 2022). Because irrigation timing is dependent on several variables, including the environment, crop type, subsurface geo-hydrological state, and development stage, it is crucial for increasing agricultural productivity. The current mechanisms for determining irrigation decisions are enforced for certain crops in a particular location, but they might be difficult to apply to other crops and regions. Crop productivity and quality are greatly influenced by the timing and quantity of water applied. For irrigation scheduling, several techniques are used, such as growth phases, leaf water potential, soil moisture base, and pan evaporation (Abioye et al., 2022). The two soil moisture parameters, soil moisture threshold and soil moisture target, at which irrigation automatically starts and stops, are typically the basis for irrigation modeling in land surface models. The parameters are typically adjusted to their optimal values, ensuring that the soil water reservoir is filled precisely and preventing crop water overflow. The main idea is that many variables affect agricultural operations, including climatic, crop, soil, technological, and human aspects. To close this gap, this article provides a novel way to calibrate soil moisture threshold and soil moisture target to reflect the amount of water used for irrigation in every situation: optimal, deficient, or even excessive (Olivera-Guerra et al., 2023).

### Irrigation scheduling

In 1996, Howell conducted a study to examine the effects of irrigation scheduling on water use. This is an application approach that can lead to efficient and effective use of water. Modern irrigation techniques can increase this efficiency. However, even with advanced irrigation technology, it is still important to implement irrigation scheduling at the farm level (Ferreira and da Cunha, 2020). When there is insufficient rainfall, evapotranspiration must compensate for the water lost. Effective irrigation scheduling aims to provide the crop with the right amount of water at the right time by calculating

crop water requirements, which are then subtracted from the amount of rainfall that falls. This can be expressed as millimeters per day or millimeters per month (Phocaides, 2007). The following parameters are monitored to supply irrigation to crops.

- Oil Moisture Status
- The Water Requirement of Crops

Understanding water quality, soil, weather, crop, and drainage conditions is necessary for agricultural production. Reviewing pumping systems' efficiency is necessary. Climate and soil types have a great influence on irrigation, including when and how much water is required. Although estimating irrigation schedules is a complicated procedure, modern technology makes it easier (Ren et al., 2011). The timing of water delivery may be set with fixed or adjustable periods to accommodate the needs of agriculture. To ensure efficiency and proper crop growth, the amount should not be greater than what is required for the crop per application, including salt leaching. Crop yields and net benefits per unit area are examples of standard performance measures (Friedman et al., 2016). The best irrigation schedule satisfies the specified limitations and maximizes the measurement of the output.

### Irrigation scheduling methods

Different irrigation techniques are available for field irrigation, each with its own benefits and limitations. The best approach should be tailored to local conditions (Jackson et al., 2011). Primary irrigation methods, such as bucket watering or wells, are time consuming and require a source of supply. Advanced methods such as sprinkler, surface, or drip irrigation are used in larger areas. The applicability of these is contingent on several aspects, including crop type, technology, previous experience, labor expenses, and benefits (García-Vila and Fereres, 2012; Dwijendra et al., 2022). The application efficiency of various irrigation techniques is shown in Table 1 and the various irrigation techniques are shown in Figure 1.

Irrigation Methods	Application Efficiency Range %
Surface Irrigation	60-70%
Sprinkler Irrigation	70-95%
Micro Irrigation.	85-95%

Source: Own calculations based on food and agriculture organization data

Table 1: Application efficiency for different irrigation systems.

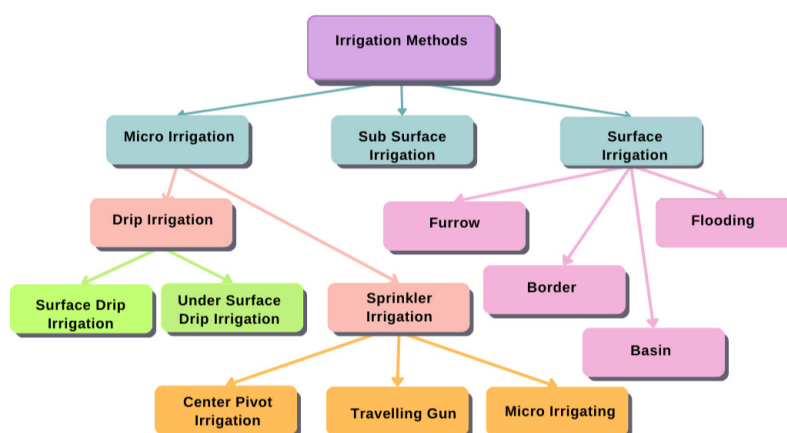

Source: Own calculations based on food and agriculture organization data

Figure 1: Different irrigation methods.

### Border irrigation

Applying water to a field's surface via gravity flow can be done in two ways: either through tiny channels called furrows or by full surface flooding known as basin irrigation (Morris et al., 2015). A contemporary technique, border irrigation uses evenly graded strips of land divided by soil bunds. This method can be fed through small gates, channel banks, spiles, or siphons. With the help of soil bunds, the water slides down the border's slope. Although borders can be up to 800 meters long and 3 to 30 meters wide, they are less appropriate for small-scale farms that rely on manual labor or animal-powered farming methods (Burguete et al., 2014).

### Sprinkler irrigation

Using rotating sprinkler heads, water is pumped through a network of pipes and sprayed over crops in a manner like that of natural rainfall. Moreover, sprinklers are used to apply the spray into the air, breaking it up into tiny water droplets that land on the ground. To apply the water evenly, the operational circumstances, pump supply system, and sprinklers must be designed (Cetin and Bilgel, 2002). For most fields, row, and tree crops, it works well. The crop canopy can be sprayed from above or below. However, larger sprinklers are not recommended for delicate crops such as lettuce since the massive water droplets they create could harm plants (Seyedzadeh et al., 2022).

### Drip irrigation

It includes the application of water to the soil at extremely low rates (2–20 l/h) by dripping it from small diameter plastic pipe systems connected

to emitters or drippers. Another name for it is trickling irrigation. Unlike surface irrigation and sprinkler irrigation, which typically irrigate the entire agricultural area, water is administered very close to plants, wetting only the soil where the roots grow. It works best when there are one or more devices connected to every plant, such as in the case of vine crops, trees, and row crops (vegetables, fruit). Because building a drip system costs a lot of money, it is only considered a viable solution for high-value crops (Pereira et al., 2007; Torres-Sanchez et al., 2020).

### Selecting an irrigation method

Selecting an irrigation system is a challenging process. Numerous factors, including crop types, soil, water, and climatic conditions, user knowledge and preferences, capital and operational expenses, and infrastructure accessibility, determine the best option for a user (Jemal and Berhanu, 2020; Zhang et al., 2021). There is no best practice for every circumstance. The following is a summary of the benefits and drawbacks of typical irrigation methods in Table 2. For sandy soils, where excessive percolation is an issue, spray or micro-watering are frequently preferable options than surface irrigation. In dry, windy regions where wind and evaporation losses might be substantial, surface irrigation may be preferable. Water-sensitive crops are better suited for micro irrigation, solid-set, or center-pivot systems as surface irrigation allows less control over application depth. Therefore, small, and frequent irrigations are impractical for these types of crops (Bakhshoodeh et al., 2022; Boutsoukiz and Arias-Moliz, 2022)

System Type	Advantages	Disadvantages
Furrow	Water flows in narrow channels and has cheap capital and maintenance expenditures.	High labor costs, poor water management, potential for soil erosion
Level basin	Efficient when designed well; requires less work than a furrow.	Losses from runoff and percolation ponded water and the need to level sloping areas
Border	The drain requires more work and produces more runoff; managing the depth of the infiltration is simpler.	Water flows over the entire surface of the soil.
Solid set	Good water control: Regular irrigation that can be automated; suits odd-shaped fields.	High initial investment: system may obstruct field operations
Set move	Less upfront costs compared to comparable sprinkler systems	Greater application depth, more labor than with traditional sprinkler systems, and inconsistent performance in windy conditions
Center pivot and linear move	High uniformity; Low labor	High initial and ongoing expenditures; Unsuitable for irregularly shaped fields; probable losses due to wind and evaporation
Traveling gun	less expensive to install than other sprinkler systems	Higher operating costs; evaporation and wind-related issues.
Micro-irrigation	Efficient water management; Potential for repeated applications	Higher initial investment; need for filtering and treatment of dirty water.

Source: Own calculations based on food and agriculture organization data

Table 2: irrigation systems' advantages and disadvantages.

### Requirement of irrigation scheduling

Irrigation scheduling is a crucial method used by farmers to determine the frequency and duration of crop watering (Isern et al., 2012). It aims to improve irrigation efficiency by providing the right amount of water to restore soil moisture. Monitoring indications are used to determine the necessity of irrigation. Precision water application is essential for optimal effectiveness. Excess or insufficient irrigation can lower crop yields, drain nutrients, wastewater, energy, and labor, and reduce soil aeration. Therefore, precise water application is crucial for effective irrigation management (Nasrullah et al., 2023). Several advantages of irrigation scheduling:

- Farmers can optimize crop yields by arranging water rotation across different fields to reduce crop water stress.
- Maximize soil moisture storage by reducing the number of irrigations needed and the labor and water costs for the farmer.
- The amount of fertilizer required is reduced by reducing surface runoff and deep percolation (leaching).
- Improve agricultural quality and productivity, which increases net returns.
- It helps to control salt problems in the root zone through controlled leaching.

### Different crop's water requirements and features

The different water requirements of cash crops and their characteristics are discussed below in Table 3. Crop irrigation water requirements refer to the difference between a crop's actual water requirement and the portion of rainfall it can utilize. The amount of water required for each crop cultivated under irrigation is calculated monthly, often in millimeters of water layer per time unit (mm/month). Crop water demand depends on factors such as crop type, climate, irrigation, rainfall, and growth stage. Crops such as rice and sugarcane require more water than beans or wheat, while sunny, hot climates require more water daily. Fully grown crops require more water than newly planted ones (Darouich et al., 2022)

Crop	Sowing Time	Height	Soil Type	Temperature	PH Level	Irrigation	Rainfall
Wheat	Oct-Dec (90-180 day)	80-120cm	Loam, Clay Loam	18°C - 26°C	6.0 to 7.0 ph	4-5 irrigations 1 <sup>st</sup> -20-25 days, 2 <sup>nd</sup> 40-45 days, 3 <sup>rd</sup> 60-65 days, 4 <sup>th</sup> 80-85 days, 5 <sup>th</sup> 100-105 days, 6 <sup>th</sup> 115-120 days after sowing	20-75 cm
Mustard	Sep-Oct (110-180 days)	160-200 cm	Light to Heavy Loamy	20°C-30°C	6.0 to 7.5 ph	1 <sup>st</sup> pre sowing irrigation, 3 after sowing at 4-week intervals and more depends on rainfall	25-40 cm
Cotton	April-May (150-180 days)	150+ cm	Sandy Loam, Clayey, Loamy Soil	20°C-40°C	6 to 8 ph	4-5 irrigations, depending on rain-fall, 1 <sup>st</sup> irrigation after sowing 4-6 weeks, remaining irrigations at intervals of 3-4 weeks	55-200 cm
Sugarcane	Feb-April (280-360 day)	8- 12+ feet	Well Drained Loamy, Clay Loam, Sandy Loam	18°C-42°C	5 to 8.5 ph	Summer every 15-20 days intervals Winter every 20-30 days intervals	75-150 cm
Guar	June-July (60-120 days)	1-2 meter	Drained Sandy Loam	28°C-32°C	7 to 8 ph	Every 20-30 days intervals and de-pends on rainfall.	100-100 cm

Source: Own calculations based on food and agriculture organization data

Table 3: Different crops water requirements and feature.

## Material and methods

### System design

The IoT architecture is composed of four layers: the website layer, the management service layer, the gateway and network layer, and the smart device or sensor device layer. Using IoT architecture, we can link the data from soil moisture sensors, rain sensors, water level sensors, and temperature sensors to think speak sever. The Node MCU is connected to various sensors, including soil moisture, temperature, rain detection, water level, and relays, to regulate the motor for optimal field irrigation. The relay is a switch that electromechanically or electronically opens and shuts circuits. The circuit is broken while the switch is open, and the circuit is complete, and the motor operates when it is closed. This switch is controlled with the aid of Node MCU programming. The Node MCU gathers data from all sources and sends it to the thing speak. Programming is done using the Arduino Integrated Development Environment (IDE). The source code editor is included. In this program the gadget using a source code editor, according to our specifications. The programming language is embedded in C. Node MCU is connected with all sensors and sensors are embedded in the agriculture field. Soil moisture sensor measures the soil's moisture content; if it falls below a threshold of 40%, the microcontroller will send a signal to a relay, which will turn on the water motor. If the soil moisture level exceeds the desired level, the microcontroller signals the relay to shut off the motor. If the moisture level is equal to the required threshold, the device

will really sit idle and wait for the next signal. To measure the water level of the tank water level sensor is used. Rain detection sensors are used to detect the rain status of the field. If the field is rainy outside, it will send a signal to the microcontroller to indicate the value of 1, if there is no rain outside, then it will send signals 0 to the microcontroller that there is no rain outside in the field. All the sensors are emended in field to detect the real-time field conditions and transfer them to the things speak for real-time monitoring of the sensors value and field conditions. The main block diagram of the system is shown in Figure 2.

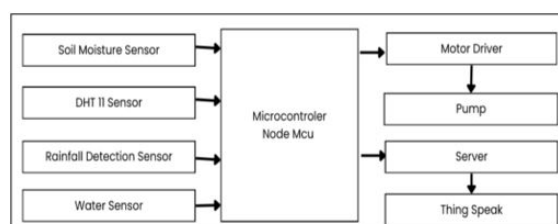

Source: Author's work

Figure 2: System block diagram.

### System working algorithm

The working of the system is shown in Figure 3:

Step 1: Start the power supply.

Step 2: Analyze the sensor data.

Step 3: The Node MCU esp8266 is used to initialize the system.

Step 4: The Thing Speak application receives updates from the DHT11 sensor, which continuously measures the field temperature and humidity.

Step 5: The field rain condition is continuously detected by the rain detection sensor, which changes the data in the Thing Speak application.

Step 6: The level of the water reservoir is continuously sensed by the water level sensor, which also changes the data in the Thing Speak application.

Step 7: The soil moisture sensor continuously measures soil moisture. If the threshold level of soil moisture is not met, then the motor that is attached to the relay will be switched on, otherwise the system will continuously measure the soil conditions from field.

Step 8: When the amount of soil moisture reaches the necessary level, the relay will automatically turn off the motor.

Step 9: As this is a continuous process, once Step 9 is achieved, the system will again start measuring the field conditions to step 2.

Step 10: This operation will continue until the system's input power is turned off. The flow chart displays both the basic principles of the system and an overview shown in Figure 3.

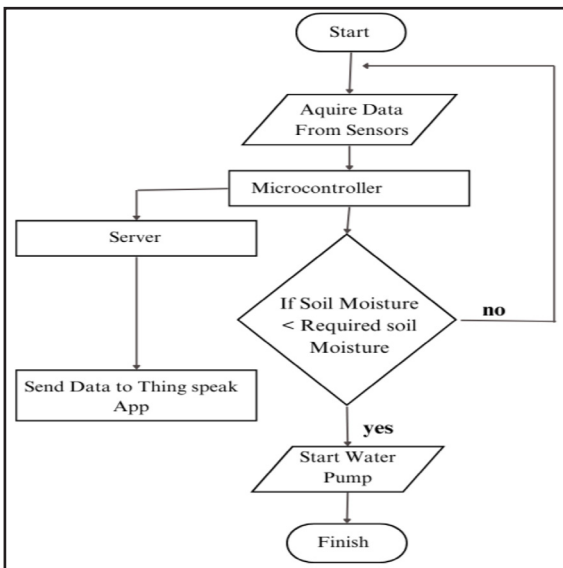

Source: Author's work

Figure 2: System block diagram.

### Hardware implementation

An analog pin attached to the YL-69 soil moisture sensor (connected to the node MCU pin A0), a rain detection sensor analog pin connected to the node MCU pin D7, and a breadboard supply power to the DHT11 sensors data pin connected to the node MCU pin D4. The Node MCU requires a voltage of 5VDC. Relay modules are required to connect the water pump motor. We will include a transistor

to change the relay module's 5V power supply to 3.3V as the ESP8266 requires a 3.3V power source. The transistor is connected to the ESP8266 via a 5k resistor. The relay signal pin is attached to the node MCU D0. An adjustable power supply and a motor pump are attached to the opposite side of the relay. The circuit for the system is shown in Figure 4. The output of the soil sensor at idle is 1023, the highest number, which then eventually drops to zero. Digital readings between 0 and 50 are sent by the temperature sensor. The Node MCU receives data from the sensors and signals from the application, acts on it, and then sends commands to the output pins and updated data to the application. Figure 4 illustrates the hardware connectivity of sensors with the Node MCU.

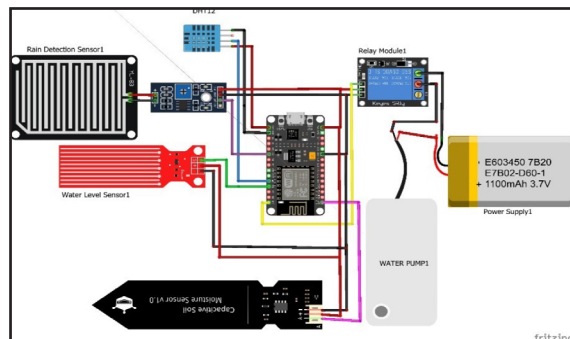

Source: Author's work

Figure 2: System block diagram.

### Result and discussion

The system must first be switched on and connected to Wi-Fi. The functioning of the system will be impacted if the internet connection is ever lost or receives a poor signal. Soil moisture sensor testing is done to monitoring the minute-by-minute variations in the moisture level. The development and testing of automated irrigation system is done successfully. The primary part of hardware in this system is the Node MCU ESP8266 module. All the sensors that are being used to collect data are saved and delivered to thing speak applications for quick and simple evaluations for additional actions and study. A more thorough explanation of each scenario of results is given below.

Condition 1: The DHT 11 sensor collects temperature and humidity data from the agriculture field and sends them to the Thing Speak server as shown in Figure 5.

Condition 2: The water level sensor collects the real-time data from the agriculture field reservoir and sends them to the Thing Speak server as shown in Figure 6.

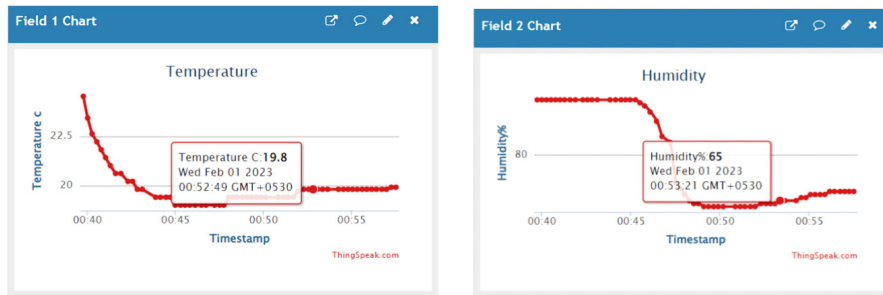

Source: Author's work

Figure 5: Temperature and humidity level status represented on Thing Speak.

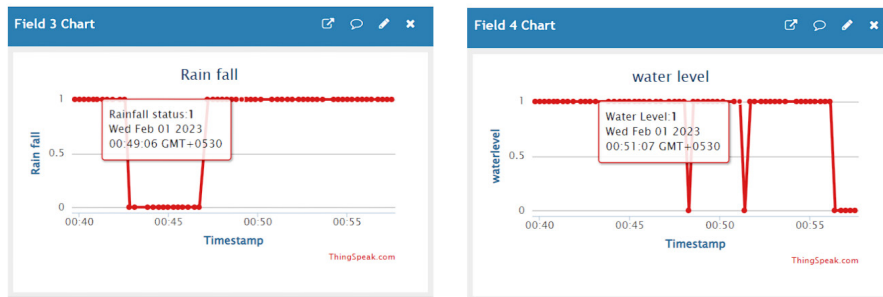

Source: Author's work

Figure 6: Water status and rain status represented on Thing Speak.

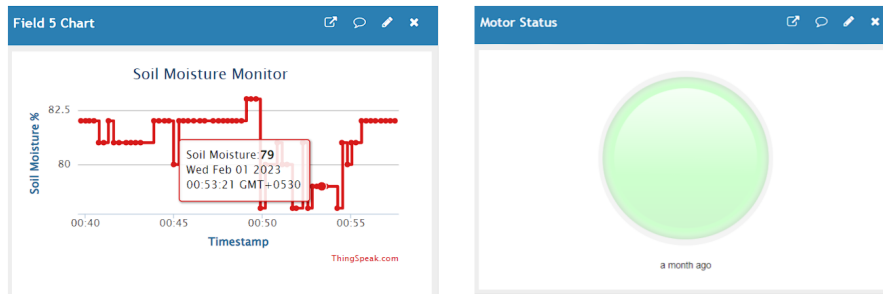

Source: Author's work

Figure 7: Soil Moisture and Motor Status represented in Thing Speak.

Condition 3: The rain detection sensor collects real-time rain data from the agricultural field and updates the Thing Speak server as shown in Figure 6

Condition 4: soil moisture sensor measure soil moisture from the agriculture filed and send to the Thing Speak server as shown in Figure 7.

Condition 5: If the soil moisture is below the required soil moisture, then the relay sends a signal to activate the irrigation motor, the off state of the motor shown in Figure 7.

## Conclusion

Agriculture is an important occupation around the world, with water scarcity being a significant factor. This article discusses various irrigation methods and their efficiency, focusing on crop water. A method using IoT techniques is presented that uses sensor data to communicate with a server via the Internet. A decision support system predicts irrigation needs and triggers relay switches through a web service. Traditional irrigation methods are still used by many farmers, but smart irrigation systems have been developed using a rule-based

approach. These systems intelligently decide the need for water and automatically switch on or off the motor, saving time and effort.

The system also monitors the status of the water tank and the field rain conditions.

*Corresponding author:*

*Dr. Devershi Pallavi Bhatt, Ph.D.*

*Department of Computer Applications, Manipal University Jaipur*

*Jaipur-Ajmer Express Highway, Dehmi Kalan,*

*Near GVK Toll Plaza, Jaipur, Rajasthan 303007, India*

*Phone: +9829321553, E-mail: bhattdevershi@gmail.com*

## References

- [1] Abioye, E. A., Hensel, O., Esau, T. J., Elijah, O., Abidin, M. S. Z., Ayobami, A.S., Yerima, O. and Nasirahmadi, A. (2022) "Precision Irrigation Management Using Machine Learning and Digital Farming Solutions", *AgriEngineering*, Vol. 4, pp. 70-103, No. 1. E-ISSN I2624-7402. DOI 10.3390/AGRIENGINEERING4010006.
- [2] Abo-Zahhad, M. M. (2023) "IoT-Based Automated Management Irrigation System Using Soil Moisture Data and Weather Forecasting Adopting Machine Learning Technique", *Sohag Engineering Journal*, Vol. 3, No. 2, pp. 122-140. E-ISSN 2735-5896, ISSN 2735-5888. DOI 10.21608/SEJ.2023.209528.1037.
- [3] Bakhshoodeh, R., Ocampo, C. and Oldham, C. (2022) "Evapotranspiration rates and evapotranspirative cooling of green façades under different irrigation scenarios", *Energy and Buildings*, Vol. 270, pp. 1-10. ISSN 0378-7788. DOI 10.1016/J.ENBUILD.2022.112223.
- [4] Boutsioukis, C. and Arias-Moliz, M. T. (2022) "Present status and future directions – irrigants and irrigation methods", *International Endodontic Journal*, Vol. 55, No. S3, pp. 588-612. ISSN 0143-2885. DOI 10.1111/IEJ.13739.
- [5] Burguete, J., Lacasta, A. and García-Navarro, P. (2014) "SURCOS: A software tool to simulate irrigation and fertigation in isolated furrows and furrow networks", *Computers and Electronics in Agriculture*, Vol. 103, pp. 91-103. ISSN 0168-1699. DOI 10.1016/J.COMPAG.2014.02.004.
- [6] Cetin, O. and Bilgel, L. (2002) "Effects of different irrigation methods on shedding and yield of cotton", *Agricultural Water Management*, Vol. 54, No. 1, pp. 1-15. E-ISSN 1873-2283. DOI 10.1016/S0378-3774(01)00138-X.
- [7] Dari, J., Quintana-Seguí, P., Morbidelli, R., Saltalippi, C., Flammini, A., Giugliarelli, E., Escorihuela, M. J., Stefan, V. and Brocca, L. (2022) "Irrigation estimates from space: Implementation of different approaches to model the evapotranspiration contribution within a soil-moisture-based inversion algorithm", *Agricultural Water Management*, Vol. 265, No. 1, p. 107537. E-ISSN 1873-2283. DOI 10.1016/J.AGWAT.2022.107537.
- [8] Darouich, H., Karfoul, R., Ramos, T. B., Moustafa, A. and Pereira, L. S. (2022) "Searching for Sustainable-Irrigation Issues of Clementine Orchards in the Syrian Akkar Plain: Effects of Irrigation Method and Canopy Size on Crop Coefficients, Transpiration, and Water Use with SIMDualKc Model", *Water*, Vol. 14, No. 13, pp. 1-12. E-ISSN 2073-4441. DOI 10.3390/W14132052.
- [9] Dwijendra, N. K. A., Abbas, Z., Salih, S. M., Opulencia, M. J. C., Morozova, L., Sergushina, E. S., Asnan, M. N., Kadhim, M. M. and Kavitha, M. (2022) "The effect of various irrigation technologies and strategies on water resources management", *Journal of Water and Land Development*, Vol. 53, pp. 143-147, E-ISSN 2083-4535. DOI 10.24425/JWLD.2022.140790.
- [10] Ferreira, L. B. and da Cunha, F. F. (2020) "New approach to estimate daily reference evapotranspiration based on hourly temperature and relative humidity using machine learning and deep learning", *Agricultural Water Management*, Vol. 234, No. 1, pp. 1-13. E-ISSN 1873-2283. DOI 10.1016/J.AGWAT.2020.106113.

- [11] Friedman, S. P., Communar, G. and Gamliel, A. (2016) "DIDAS – User-friendly software package for assisting drip irrigation design and scheduling", *Computers and Electronics in Agriculture*, Vol. 120, No. 1, pp. 36-52. ISSN 0168-1699. DOI 10.1016/J.COMPAG.2015.11.007.
- [12] García-Vila, M. and Fereres, E. (2012) "Combining the simulation crop model AquaCrop with an economic model for the optimization of irrigation management at farm level", *European Journal of Agronomy*, Vol. 36, No. 1, pp. 21-31. ISSN 1161-0301. DOI 10.1016/J.EJA.2011.08.003.
- [13] Isern, D., Abelló, S. and Moreno, A. (2012) "Development of a multi-agent system simulation platform for irrigation scheduling with case studies for garden irrigation", *Computers and Electronics in Agriculture*, Vol. 87, No. 1, pp. 1-13. ISSN 0168-1699. DOI 10.1016/J.COMPAG.2012.04.007.
- [14] Jackson, T. M., Hanjra, M. A., Khan, S. and Hafeez, M. M. (2011) "Building a climate resilient farm: A risk based approach for understanding water, energy and emissions in irrigated agriculture", *Agricultural Systems*, Vol. 104, No. 9, pp. 729-745. ISSN 0308-521X. DOI 10.1016/J.AGSY.2011.08.003.
- [15] Jemal, K. and Berhanu, S. (2020) "Effect of Water Application Methods in Furrow Irrigation Along with Different Types of Mulches on Yield and Water Productivity of Maize (*Zea mays* L.) at Hawassa, Ethiopia", *Journal of Natural Sciences Research*, Vol. 10, No. 5, pp. 1-10. ISSN 2225-0921. DOI 10.7176/JNSR/10-5-01.
- [16] Kondaveti, R., Reddy, A. and Palabtlá, S. (2019) "Smart Irrigation System Using Machine Learning and IOT", *Proceedings - International Conference on Vision Towards Emerging Trends in Communication and Networking, ViTECoN 2019*, Institute of Electrical and Electronics Engineers Inc. ISBN 9781538693544. DOI 10.1109/VITECON.2019.8899433.
- [17] Morris, M. R., Hussain, A., Gillies, M. H. and O'Halloran, N. J. (2015) "Inflow rate and border irrigation performance", *Agricultural Water Management*, Vol. 155, No. 1, pp. 76-86. E-ISSN 1873-2283. DOI 10.1016/J.AGWAT.2015.03.017.
- [18] Nasrullah, M., Liang, L. and Rizwanullah, M. (2023) "Estimating the efficiency gap of maize yield across different irrigation methods in Pakistan", *Irrigation and Drainage*, Vol. 72 No. 1, pp. 166-181. E-ISSN 1531-0361. DOI 10.1002/IRD.2750.
- [19] Olivera-Guerra, L. E., Laluet, P., Altés, V., Ollivier, C., Pageot, Y., Paolini, G., Chavanon, E., Rivalland, V., Boulet, G., Villar, J.-M. and Merlin, O. (2023) "Modeling actual water use under different irrigation regimes at district scale: Application to the FAO-56 dual crop coefficient method", *Agricultural Water Management*, Vol. 278, pp. 1-10. E-ISSN 1873-2283. DOI 10.1016/J.AGWAT.2022.108119.
- [20] Pereira, L. S., Gonçalves, J. M., Dong, B., Mao, Z. and Fang, S. X. (2007) "Assessing basin irrigation and scheduling strategies for saving irrigation water and controlling salinity in the upper Yellow River Basin, China", *Agricultural Water Management*, Vol. 93, No. 3, pp. 109-122. E-ISSN 1873-2283. DOI 10.1016/J.AGWAT.2007.07.004.
- [21] Phocaidés, A. (2007) "Handbook on Pressurized Irrigation Techniques", FAO, 288 p. ISBN 9789251058176.
- [22] Ren, W., Xiang, Q., Yang, Y., Cui, H. and Dai, L. (2011) "Implement of Fuzzy Control for Greenhouse Irrigation", *IFIP Advances in Information and Communication Technology*, Vol. 344, pp. 267-274. ISSN 1868-422X. DOI 10.1007/978-3-642-18333-1\_31.
- [23] Saggi, M. K. and Jain, S. (2022) "A Survey Towards Decision Support System on Smart Irrigation Scheduling Using Machine Learning approaches", *Archives of Computational Methods in Engineering*, Vol. 29, No. 6, pp. 4455-4478. E-ISSN 1886-1784. DOI 10.1007/S11831-022-09746-3.
- [24] Seyedzadeh, A., Khazaei, P., Siosemardeh, A. and Maroufpoor, E. (2022) "Irrigation management evaluation of multiple irrigation methods using performance indicators", *ISH Journal of Hydraulic Engineering*, Vol. 28, No. 3, pp. 303-312. ISSN 0971-5010. DOI 10.1080/09715010.2021.1891470.

- [25] Tace, Y., Tabaa, M., Elfilali, S., Leghris, C., Bensag, H. and Renault, E. (2022) "Smart irrigation system based on IoT and machine learning", *Energy Reports*, Vol. 8, No. 9, pp. 1025-1036. ISSN 2352-4847. DOI 10.1016/J.EGYR.2022.07.088.
- [26] Torres-Sanchez, R., Navarro-Hellin, H., Guillamon-Frutos, A., San-Segundo, R., Ruiz-Abellón, M. C. and Domingo-Miguel, R. (2020) "A Decision Support System for Irrigation Management: Analysis and Implementation of Different Learning Techniques", *Water*, Vol. 12, pp. 548, Vol. 12 No. 2, pp. 1-10. E-ISSN 2073-4441. DOI 10.3390/W12020548.
- [27] Zhang, T., Zou, Y., Kisekka, I., Biswas, A. and Cai, H. (2021) "Comparison of different irrigation methods to synergistically improve maize's yield, water productivity and economic benefits in an arid irrigation area", *Agricultural Water Management*, Vol. 243, No. 1, pp. 1-10. E-ISSN 1873-2283. DOI 10.1016/J.AGWAT.2020.106497.