



AgEcon SEARCH

RESEARCH IN AGRICULTURAL & APPLIED ECONOMICS

The World's Largest Open Access Agricultural & Applied Economics Digital Library

This document is discoverable and free to researchers across the globe due to the work of AgEcon Search.

Help ensure our sustainability.

Give to AgEcon Search

AgEcon Search

<http://ageconsearch.umn.edu>

aesearch@umn.edu

*Papers downloaded from **AgEcon Search** may be used for non-commercial purposes and personal study only. No other use, including posting to another Internet site, is permitted without permission from the copyright owner (not AgEcon Search), or as allowed under the provisions of Fair Use, U.S. Copyright Act, Title 17 U.S.C.*

No endorsement of AgEcon Search or its fundraising activities by the author(s) of the following work or their employer(s) is intended or implied.

Caribbean Regional Climate Sub Hub Assessment of Climate Change Vulnerability and Adaptation and Mitigation Strategies



Local produce at the farmers' market in Santurce, Puerto Rico (Photo credit: Victor Cuadrado)

Authors: William A. Gould, U.S. Forest Service (USFS) International Institute of Tropical Forestry (IITF) Research Ecologist, Caribbean Sub Hub Director; Stephen J. Fain, Caribbean Sub Hub Strategic Analyst, Yale University graduate student; Isabel K. Pares, Caribbean Sub Hub Coordinator; Kathleen McGinley, USFS IITF Social Scientist; Ann Perry, ARS Public Affairs Specialist; and Rachel F. Steele, National Climate Hubs Coordinator.

Caribbean Sub Hub
International Institute of Tropical Forestry
USDA Forest Service
1201 Calle Ceiba
Rio Piedras, PR 00926-1119

September 2015

Contributors: Our thanks to Edwin Almodovar, NRCS; Juliet Bochicchio, RD; Kimme Bryce, RD; Rudy O'Reilly, RD; Michelle Thurland-Martinez, RD; Wendy Hall, APHIS; Marlene Cole, APHIS; José Urdaz, APHIS; Sharon Hestvik, RMA; Juan M. Ortiz Serbiá, FSA; Rick Dantzler, FSA; Ricardo Goenaga, ARS; Carlos Hasbun, FAS; and Virgilio Mayol, FAS.

Edited by: Ann Perry, ARS

Suggested Citation: Gould, W.A., S.J. Fain, I.K. Pares, K. McGinley, A. Perry, and R.F. Steele, 2015: *Caribbean Regional Climate Sub Hub Assessment of Climate Change Vulnerability and Adaptation and Mitigation Strategies*, United States Department of Agriculture, 67 pp

Contents

Letter from the Regional Lead.....	4
1. Introduction	6
1.1 Description of the Region and Key Resources	6
Puerto Rico.....	7
U.S. Virgin Islands.....	8
General Climate Description.....	8
1.2 Demographics and land uses.....	10
1.3 Caribbean Climate Vulnerability	14
2. Regional Agriculture’s Sensitivity to Climate Change and Adaptation Strategies	15
2.1 Cropping Systems Overview of Risks, Vulnerabilities and General Adaptation Strategies.....	15
Coffee.....	17
Grasses	21
Specialty Crops (Fruits and Vegetables).....	24
2.2 Livestock Systems Overview of Risks, Vulnerabilities and General Adaptation Strategies	27
Beef and dairy industry in Puerto Rico	27
Beef and dairy industry in the U.S. Virgin Islands	28
2.3 Climate-related Vulnerability: Effects of 2014 drought on agriculture and livestock in Puerto Rico.....	31
Adaptation planning needs.....	31
3. Forest Systems Overview of Risks, Vulnerabilities and General Adaptation Strategies.....	32
3.1 Forest System Vulnerabilities	33
4. Additional Socioeconomic Factors Contributing to Regional Vulnerability.....	35
4.1 Issues of agricultural planning, infrastructure and production costs.....	36
4.2 High production costs due to high energy costs.....	37
4.3 Vulnerability of Food Supply Chains in Puerto Rico and the U.S. Virgin Islands.....	38
Water Issues in Puerto Rico and the U.S. Virgin Islands.....	40
Erosion and Agricultural Water Supply.....	40
Water Quality and Tourism.....	41
5. Potential Agribusiness and Niche-markets in the U.S. Caribbean	42
5.1 Hydroponics and Organic Agriculture: A case for climate resilient farming businesses	43
5.2 Commercial Aquaponics and Aquaculture	43
6. Research and Sustainable Practices for Climate Change Adaptation and Mitigation	44
6.1 Use of tropical forages for climate-smart livestock production.....	44

6.2	Bean Breeding Program at the University of Puerto Rico in Mayagüez: New bean germplasm for drought tolerance and disease resistance.....	44
6.3	Warming Experiment at the Luquillo Experimental Station in El Yunque National Forest.....	45
7.	USDA Programs	45
7.1	Natural Resources Conservation Service	45
	The Role of NRCS in the Caribbean.....	46
7.2	United States Forest Service	46
	National Forest System.....	46
	Research and Development.....	47
	Regional Stations	47
	Forest Service Cooperative Forestry Program	47
	National Agroforestry Center.....	48
	The Role of the Forest Service in the Caribbean	48
7.3	Farm Service Agency.....	48
	The Role of FSA in the Caribbean.....	49
7.4	Rural Development	49
	The Role of Rural Development in the Region.....	50
7.5	Risk Management Agency	50
7.6	Animal and Plant Health Inspection Service	51
7.7	Agricultural Research Service	54
	The Role of ARS in the Region	55
7.8	Foreign Agricultural Service (FAS).....	55
	Programs and Services.....	55
8.	Conclusions	56
	References.....	58

Letter from the Regional Lead

The USDA Caribbean Climate Sub Hub for Tropical Forestry and Agriculture (CCSH) is located at the U.S. Forest Service International Institute of Tropical Forestry in Río Piedras, Puerto Rico. The geographic scope of the CCSH includes the U.S. Caribbean Islands of Puerto Rico, Vieques, and Culebra and the U.S. Virgin Islands of St. Thomas, St. Croix, and St. John. The U.S. Caribbean is an integral part of a socially, economically, and ecologically diverse region and we hope that the work of the CCSH is relevant to tropical forestry and agriculture throughout the Neotropics. The wider Caribbean includes over 120 major islands and thousands of cays and islets. There are 28 countries and more than 42 million inhabitants. The climate is tropical and the range of agricultural and forestry products reflect the lack of frost, low degree of annual variation in temperature, high spatial and temporal variation in precipitation, frequent drought and storm events, and a combination of high biological diversity and high levels of endemism. However, there is also a range of cosmopolitan flora and fauna resulting from a long history of human commerce and interaction in the region. Much of the Caribbean's physical geography is comprised of coastal areas and many islands exhibit complex geology and topography. These factors influence soil types and distributions, hydrological processes, and local climate, which in turn affect forestry and agricultural production.

Agriculture and forestry practices in the U.S. Caribbean have had 500 years of North American, European, and African influence, as well as the legacy of indigenous cultures and farming practices. There is also a century of high caliber research in agriculture and forestry at local universities, Federal research agencies, and affiliated partners. In the last century, Puerto Rico and the Island economies have shifted from agricultural self-sufficiency to economies that rely heavily on imported lumber and food products. However, the climate, soils, and available land and water are very conducive to high productivity and there is widespread interest in working to reinvigorate the contribution of forestry and agriculture to the economy, job creation, and improving the quality of life. Current important crops in the U.S. Caribbean include coffee; grass and pastureland for dairy cattle and other livestock; fruits, vegetables and root crops; and ornamental products. Forestry and agricultural products are obtained from a wide range of plant species and cultivars that are produced in a diverse array of ecosystems, and they exhibit significant variations in pest resistance and heat and water stress tolerance. According to the International Panel on Climate Change (IPCC), climate is expected to warm and dry over the next century, with increasingly intense storm events. This may lead to both increased drought and increased susceptibility to flooding. The region's wide array of crops will exhibit a range of responses to these changes and a detailed understanding is needed of both crops and climate to develop effective adaptation plans. As a whole, the forestry and agricultural sectors in the Caribbean are highly vulnerable to climate change effects for a number of reasons:

- Threats to food security;
- New vulnerabilities to pests that affect humans, livestock, wildlife and plants;
- Sea level rise and salt water intrusion that affect coastal populations and prime agricultural lands;
- There is limited land available for growth and migration;
- The Caribbean is a global biodiversity hotspot;
- Unemployment and poverty levels are among the highest in the United States;
- A majority of farms lack access to specialized expertise, information, research, or equipment to adapt to climate change, and/or lack the ability to make needed adjustments to their production systems.

The CCSH will work to reduce the risks climate change may bring to the agriculture and forestry sectors. The CCSH will serve as a framework to enhance the USDA response in developing and delivering research and information that will increase local productivity, support innovative products and markets, provide regular vulnerability assessments, develop tools for farmers and managers to increase their

adaptive capacity, and serve as a clearinghouse for information on climate, agriculture, and forestry in the Caribbean.

William Gould

Caribbean Climate Sub Hub Lead



1. Introduction

The United Nations Intergovernmental Panel on Climate Change (IPCC) has deemed climate change a serious threat to agriculture and food security worldwide (Intergovernmental Panel on Climate Change, 2014). In addition, the U.S. Department of Agriculture (USDA) acknowledges that climate change has the potential to ‘confound’ the advancement of its mission and core obligation “to provide leadership on food, agriculture, natural resources, rural development, nutrition, and related issues through an evolving service role at the nexus of traditional rural American food, fiber, and fuel production and the emerging economic opportunities in renewable energy, broadband, and recreation” (U.S. Department of Agriculture, 2014b). Over the next 25 years, the effects of climate change to agriculture and forestry in the United States are likely to be mixed, but generally they are expected to amplify current biotic stressors. The overall effects will depend largely on the adaptive actions taken by land managers and producers (Walthall et al., 2012).

Response to climate change is a central theme in the USDA’s 2014-2018 Strategic Plan. The second of the Plan’s five goals is to ensure National forests and private working lands are conserved, restored, and made more resilient to climate change, while enhancing water resources (U.S. Department of Agriculture, 2014a). As an action point to this strategic goal, USDA has established seven Regional Climate Hubs and three Sub Hubs to deliver science-based knowledge and practical information to farmers, ranchers, and forest landowners to support decision making related to climate change. The Hubs will provide technical support, assessments and forecasts, and outreach and education. Each Hub and Sub Hub is designed to be the nexus of a network of connected activities or services. Operational centers for each Hub will be located either in a regional facility operated by USDA’s Agricultural Research Service (ARS) or USDA’s Forest Service (USFS). The Hubs are expected to maintain a dynamic network of public, academic, and private sector organizations, researchers, and outreach specialists in order to address vulnerabilities to climate change within forestry and agriculture (U.S. Department of Agriculture, 2014b). As part of this Hub network, the Caribbean Climate Sub Hub (CCSH) is focused on tropical forestry and agriculture and engaged in vulnerability assessments for the U.S. Caribbean region. This report is an initial step in these efforts.

1.1 Description of the Region and Key Resources

Agriculture and forestry activities in the Caribbean are diverse, and include products such as coffee, tropical fruits, ornamentals, beans, root crops, livestock, dairy products, and timber. Caribbean residents depend heavily on these products for subsistence and as valuable cash crop exports. The U.S. Caribbean, Puerto Rico and the U.S. Virgin Islands region relies heavily on imported agricultural and timber products and local production is far below its full potential. Increasing production capacity could improve food security, rural standards of living, and territorial economies, as well as increase opportunities to preserve aspects of the region’s unique culture.

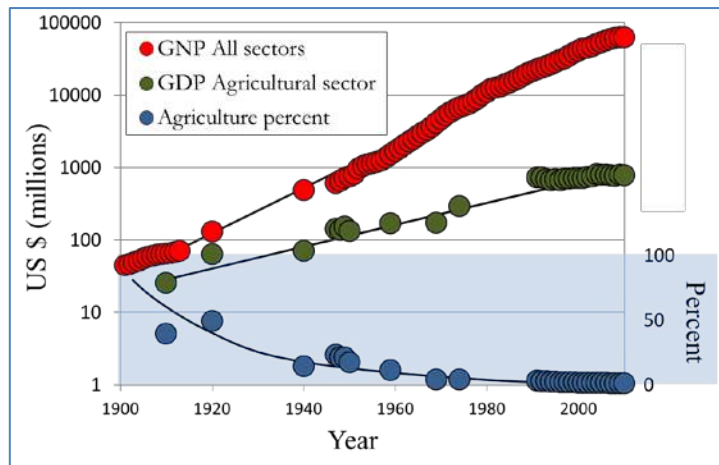

Figure 1: Relative contribution of the agricultural sector to the GNP of Puerto Rico has dropped from 50 percent to less than 1 percent in the last century. (Sources: Puerto Rico Department of Agriculture, Office of Agricultural Statistics and Dietz (1986).

Puerto Rico

The Commonwealth of Puerto Rico is the eastern most and smallest island within the Greater Antilles archipelago and is located roughly between the latitudes of 17° 45' and 18° 30' N, and longitudes of 65° 45' and 67° 15' W (Daly et al., 2003). The territory consists of the main island, which bears its name, and five smaller nearby islands and cays. The largest of these nearby islands, Vieques and Culebra, are considered part of the lesser Antilles and are often referred to as the 'Spanish Virgin Islands.' The Puerto Rican central mountain chain exceeds 600 m above sea level and has 63 peaks ranging between 2625 ft. (800 m) and 4390 ft. (1338 m). This Cordillera Central forms a barrier to the predominant northeast trade winds and casts a rain shadow over most of the southern coast, which averages less than 49 in (1140 mm) of rain annually. Areas north of the Cordillera receive an estimated annual rainfall average of 79 in (2030 mm). With an estimated overall average annual rainfall of 70 in (1780 mm), Puerto Rico has a yearly water budget of around 11,600 million gallons per day (Hunter & Arbona, 1995).

Much of the interior of the main island consists of a mountain range known as the Cordillera Central, which generally divides the wetter northern portion of the island from the more arid south. The Sierra de Luquillo, located in northeastern Puerto Rico, is smaller and isolated from the central range, but plays an important role in the island's ecological diversity. It is home to El Yunque National Forest, which is the only tropical rainforest within the National Forest system.

As recently as the 1930s, 90 percent of the main island's 2.2 million acres were in agricultural land use, over 70 percent of the population lived in rural areas, and agriculture accounted for 45 percent of the gross domestic product (GDP) (Chazdon, 2008; Grau et al., 2003). As a response to the collapse of the sugar industry and other struggles within the agricultural sector, Puerto Rican society began a deliberate shift toward a more industrialized economy in the 1940s. Agriculture now represents less than 1 percent of Puerto Rico's GDP (Figure 1). The rural to urban migration resulted in the abandonment of many agricultural lands as farmers replaced agrarian activities with jobs in the manufacturing and service industries (Grau et al., 2003). This socioeconomic transformation has occurred in other Caribbean islands as well and has led to a region-wide decline in the agricultural sector (Figure 2).

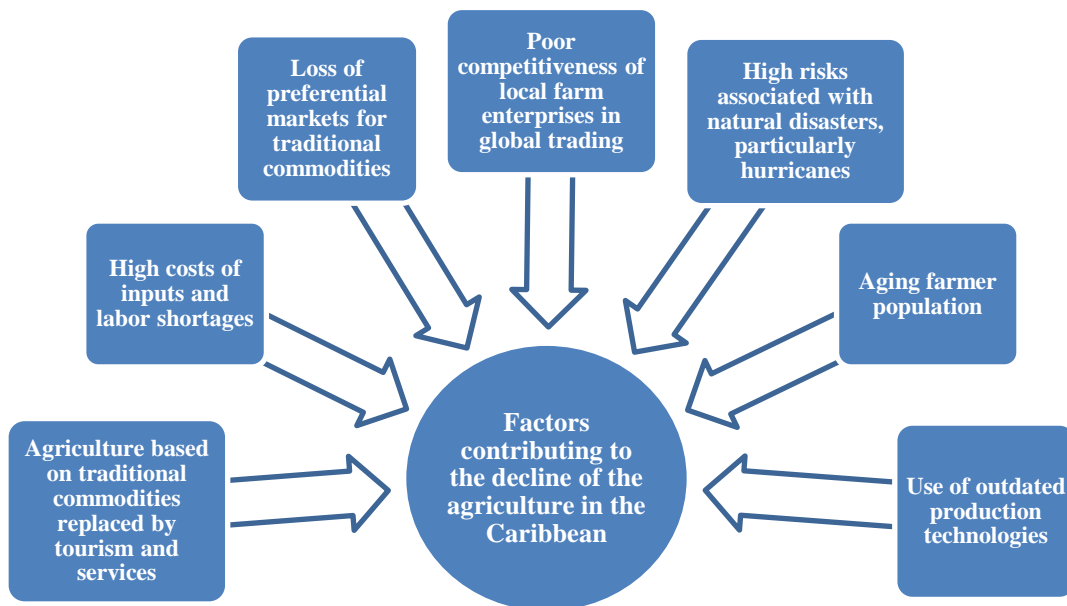

Figure 2: Socio-economic factors contributing to the decline of agriculture in the Caribbean region (adapted from Ganpat & Isaac, 2014).

U.S. Virgin Islands

Europeans first contact with the islands that now comprise the U.S. Virgin Islands came during Christopher Columbus' second voyage to the New World in 1493. Largely neglected by the Spanish Empire, various European colonial powers vied for control of the islands throughout the 17th century. As with much of the Caribbean, European demand for sugar drove the initial settlement and development of the islands (Mintz, 2007). By 1718, the Danes had established themselves in St. Thomas and were able to expand to St. John, constructing a fort at Coral Bay. In 1733, Denmark purchased the island of St. Croix from France uniting the territory now known as the U.S. Virgin Islands. Due to its strategic geographic positioning, protected harbor, and the neutrality of the Danes throughout many of the colonial wars of the 17th century, St. Thomas became an important center of trade within the Caribbean. St. Croix presented excellent growing conditions for sugarcane and by the mid-18th century had become the 6th largest producer of sugar in the region, well ahead of Puerto Rico and Cuba (Dookhan, 1974). The much steeper terrain of St. John and St. Thomas made cultivation more difficult, but these islands still managed to produce over two million pounds of sugar in 1796 alone (Dookhan, 1974). Negotiations for the U.S. purchase of the islands from Denmark began in 1867, but were not completed until 1917, when the United States finally acquired the territory for \$25 million (Davis & Santiago, 2000).

Agriculture continued to be important through the early 20th century, but by the 1960s the islands saw a shift toward manufacturing and tourism as the main economic activities. Today, tourism drives the islands' economy and contributes up to 80 percent of the U.S. Virgin Island's GDP (CIA World Factbook, 2014). As in Puerto Rico, U.S. Virgin Islands residents depend on imports from the continental United States for the majority of their food and domestic products. The agricultural and aquaculture sector in the Virgin Islands is modest and comprised largely of smallholder farmers producing on-island goods for local consumption (Wedderburn et al., 2008). Manufacturing, including petroleum refining and rum production, was second in economic importance until the February 2012 closure of the Hovensa crude oil refinery on St. Croix.

General Climate Description

Puerto Rico and the U.S. Virgin Islands fall within a tropical climate zone and experience moderate annual temperature variations. Temperature variations in both territories are affected by elevation and regional weather patterns, and can range from wintertime lows of 50 °F in the Cordillera Central of Puerto Rico to summertime highs of 95°F in the southwest portion of the island. Average temperatures in Puerto Rico are 70°F to 90° F in the lower elevations and 60°F to 80°F in the higher elevations, with average temperature variations of 6° F between the winter and summer months (Southeastern Regional Climate Center, 2015). The warmest average months in the region are July and August. The eastern slopes of the Sierra de Luquillo receive the highest amounts of precipitation, with average annual totals of over

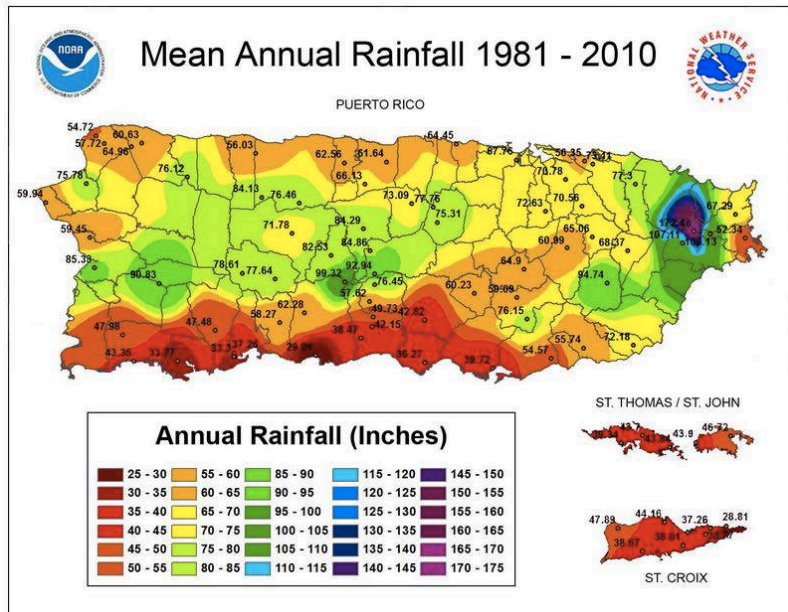

Figure 3: Mean Annual Rainfall 1981-2010 (Source: NOAA http://www.srh.noaa.gov/sju/?n=mean_annual_precipitation)

100 inches (Kunkel et al., 2013). Although rainfall frequencies and amounts vary significantly due to topographic effects within the island, the northern and central portions of Puerto Rico tend to be wetter, with a pronounced rainy season from April to November (Southeastern Regional Climate Center, 2015). The Virgin Islands experience less topographically-induced precipitation and are climatically similar to the southern portion of Puerto Rico (Figure 3).

Caribbean High-Resolution Climate Projections and Puerto Rico Downscale Climate Data

This research was led by Dr. Katharine Hayhoe of Texas Tech University and explored the potential effects of climate change in various Caribbean islands. Dr. Hayhoe used 32 different global climate models to simulate observed temperature and rainfall variability over the Caribbean and to generate future projections of temperature and precipitation for Puerto Rico. These future projections were analyzed in terms of model performance and changes projected for a range of global mean temperature targets, from +1 to +3°C, relative to 1971-2000. Projected changes were divided into two regions for temperature (hot coastal and more temperate inland) and three regions for precipitation (dry northern coast, dry southern coast, and wet inland locations).

Products from this research that are available for download at CLCC Data Center (www.caribbeanlcc.org) include:

- Quantitative datasets of raw climate projections for long-term weather stations in the Caribbean
- Qualitative analysis of global climate model performance over the Caribbean
- Quantitative analysis of projected climate changes for Puerto Rico stations

Results for Puerto Rico:

- Rainfall is projected to decrease, particularly in the wet season, with more frequent dry days. Precipitation in the Puerto Rico and the central Caribbean is characterized by a summer wet season ranging from May to November, and includes a mid-summer drought (MSD).
- The frequency of ‘moderate extreme’ precipitation (more than 1 inch of rain) is projected to decrease, while more extreme precipitation (more than 3 inches of rain in a day) is expected to become more common.
- Air temperatures in Puerto Rico are expected to warm faster than the global average. Increases are expected in both mean and extreme temperatures, including days per year over 95°F and nights warmer than 85°F.
- With just 1°C increase in global temperature, 60 percent of the wet seasons are projected to be warmer than the historical maximum. On average, there would be 100 more days over 85°F, 150 more days over 90°F and 35 more days over 95°F each year.
- With a 2°C increase in global temperature, every day would be warmer than the historical median, 350 days per year will be warmer than the historical 1-in-4 warmest days and 300 days per year will be warmer than the historical 1-in-10 warmest days.
- Increases are projected to be greater for inland locations and for nighttime temperatures (over 8°C).
- Per-degree global mean temperature change and temperature on the warmest day of the year is projected to increase by 3°C while cooling degree-days (a measure of air conditioning demand) are projected to increase by 600. The range of daily temperature is expected to increase, particularly in the wet season.
- Projected temperature changes are large enough to affect temperature-sensitive crops, species, and ecosystems, while the combined effects of changes in temperature and precipitation are likely to increase energy demands, water stress and drought risks, and risks associated with heavy rainfall events.

Reference: (Hayhoe, 2013)

1.2 Demographics and land uses

Population in Puerto Rico and the U.S. Virgin Islands is just under 4 million people and has been declining in the recent decade (Table 1). Land uses are most strongly controlled by topography and the steep climatic gradients represented on the islands (Figure 4). Agricultural trends are most strongly influenced by global and local market conditions, including government policy and planning, but episodic storms and drought events play a significant role.

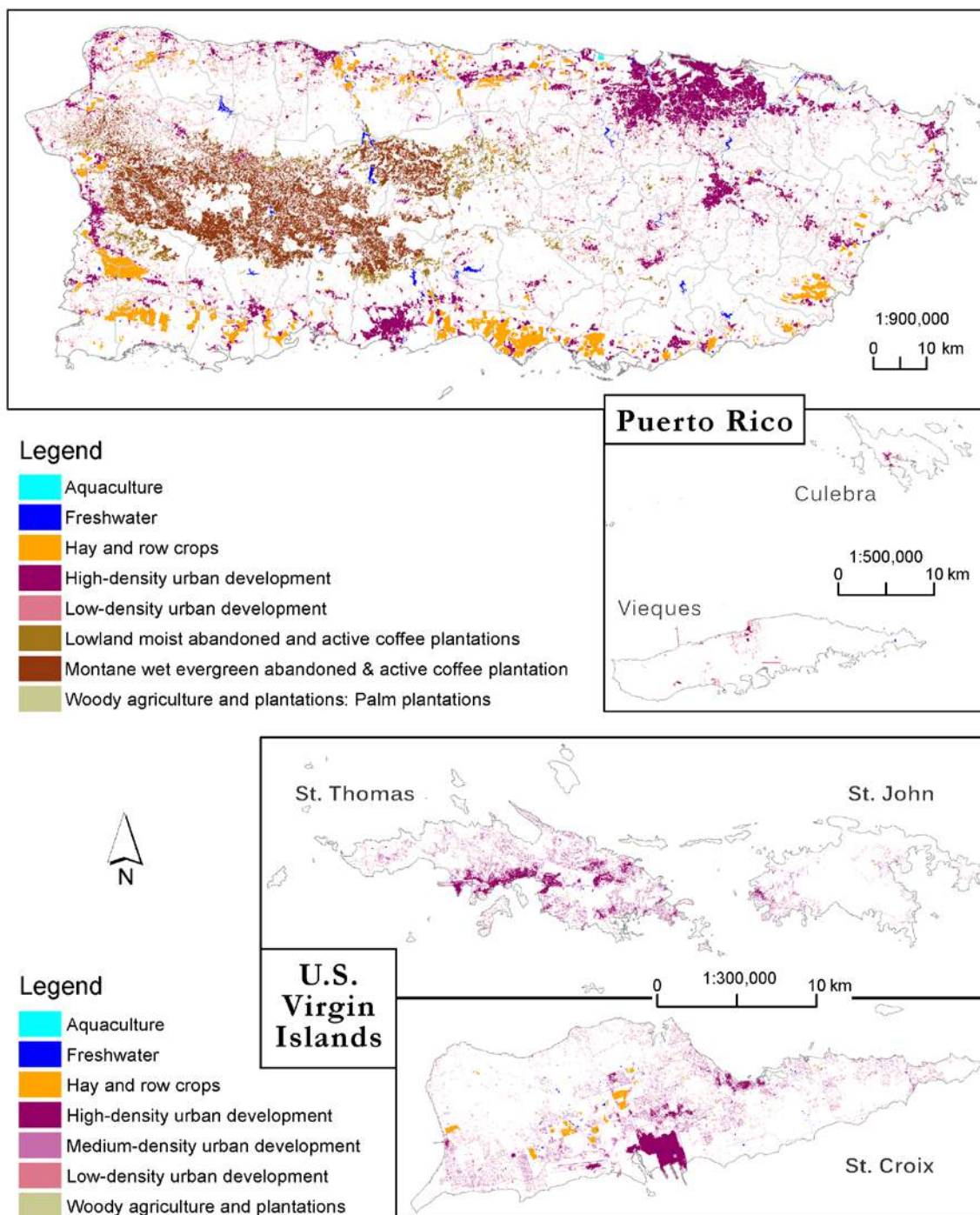

Figure 4: Agricultural and developed land cover of Puerto Rico (2000) and the U.S. Virgin Islands (2007) Source : (Gould et al., 2008).

Caribbean Region

Table 1: Comparative profiles of Puerto Rico and the US Virgin Islands. Source: (CIA World Factbook, 2014).

Country profile		Puerto Rico	U.S. Virgin Islands
Demography	Population	3,620,897 (July 2014 est.)	104,170 (July 2014 est.)
	Pop. Growth rate	-0.65 percent (2014 est.)	-0.56 percent (2014 est.)
	Net migration rate	-8.93 migrant(s)/1,000	-7.84 migrant(s)/1,000
	Unemployment rate	16 percent (2011 est.)	13 percent (2014)
Economy	GDP per capita (ppp)	\$16,300 (2010 est.)	\$14,500 (2004 est.)
	GDP (ppp)	\$64.84 billion (2010 est.)	\$1.577 billion (2004 est.)
	GDP: real growth rate	-5.8 percent (2010 est.)	2 percent (2002 est.)
	GDP: composition, by sector of origin	Agriculture: 0.7 percent; industry: 48.8 percent; services: 50.5 percent (2013 est.)	Agriculture: 1 percent; industry: 19 percent; services: 80 percent (2003 est.)
	Industries	Pharmaceuticals, electronics, apparel, food products, tourism.	Tourism, watch assembly, rum distilling, construction, pharmaceuticals, electronics.
	Economy overview	Economic growth has been negative for the past 4 years. The industrial sector has surpassed agriculture as the primary locus of economic activity and income. U.S. minimum wage laws apply. Sugar production has lost out to dairy production and other livestock products as the main source of income in the agricultural sector. Tourism is an important source of income with more than 3.6 million visitors in 2008. Closing the budget deficit and restoring economic growth and employment remain the central concerns of the government.	Tourism, trade, and other services are the primary economic activities, accounting for roughly 57 percent of GDP and about half of total civilian employment in 2010. The islands hosted nearly 2.74 million visitors - 2.2 million cruise ship and 536,000 air passengers - in 2011. Industry and government each account for about one-fifth of GDP. The agriculture sector is small, with most food being imported. The Hovensa refinery, which provided 90 percent of the fuel for the U.S. Virgin Islands, ended production in February of 2012.
Geography	Total area	13,790 km ²	1,910 km ²
	land	8,870 km ²	346 km ²
	water	4,921 km ²	1,564 km ²
	Coastline	501 km	188 km
	Climate	Tropical marine, mild; little seasonal temperature variation; rainy season May to November	Subtropical, relatively low humidity, little seasonal temperature variation; rainy season September to November.
	Terrain	Mostly mountains with coastal plain belt in north; mountains to sea on west coast; sandy beaches in coastal areas.	Mostly hilly to rugged and mountainous with little level land.
	Land use	Arable land: 6.76 percent Permanent crops: 4.51 percent Other: 88.73 percent (2011)	Arable land: 2.86 percent Permanent crops: 2.86 percent Other: 94.29 percent (2011)
	Irrigated land	220 km ² (2005)	1 km ² (2011)
	Natural hazards	Hurricanes; periodic droughts and floods.	Hurricanes; periodic droughts and floods
	Environmental issues	Erosion; droughts causing water shortages.	Lack of natural freshwater resources.

Trends in the Puerto Rican agricultural sector from 2007 to 2012 (National Agricultural Statistics Service, 2014a):

- Total farmland increased 5 percent from 557,530 cuerdas (540, 804 acres) to 584,988 cuerdas (567,438 acres) (one cuerda equals 0.97 acre);
- Number of farms on the island decreased 16 percent, from 15,745 to 13,159;
- The average size of a Puerto Rico farm increased by 26 percent, from 35.4 to 44.5 cuerdas (34 to 44 acres);
- Harvested cropland increased 10 percent, from 116,198 to 127,372 cuerdas (112,722 to 123,550 acres);
- Coffee grown in the open accounted for the largest amount of harvested cropland, with 23,876 cuerdas (23,160 acres). Total coffee harvested (including shade coffee) equaled 33,213 cuerdas (32,217 acres) in 2012;
- The total value of agriculture sales increased 6 percent, from \$516 million to \$548 million;
- Milk production was the largest single category of farm sales, generating \$189 million in 2012 (35 percent of the total value of agriculture sales);
- The value of coffee and nursery crops sales decreased, while the sales value of bananas, fruits and coconuts, plantains and vegetables increased (Figure 5);
- The total dollar value of sales generated by farms selling organically-produced commodities increased over 90 percent, from \$40,000 to \$421,000;
- The number of hydroponic farms increased from 156 to 213 farms and its production value increased by over \$7 million;
- Irrigated farmland increased 34 percent, from 39,707 to 53,361 cuerdas (38,516 to 51,760 acres);
- The number of farms using organic fertilizer increased from 295 to 507 farms, a 72 percent increase;
- The total number of beef cattle raised grew by 22 percent, from 75,000 to about 96,000;
- The average farm expenses increased, particularly from purchases of animal feed for livestock and poultry, which averaged over \$24,000 a year per farm. Average payroll expenses also increased to over \$20,000 a year per farm.

Trends in the U.S. Virgin Islands' agricultural sector from 2002 to 2007 (National Agricultural Statistics Service, 2009b):

- Total farmland decreased 36 percent, from 9,168 acres to 5,881 acres;
- Number of farms increased 15 percent, from 191 farms to 219 farms;
- The average size of a farm decreased by 44 percent from 48.0 to 26.9 acres;
- Harvested cropland decreased 50 percent, from 602 acres to 304 acres;
- The total value of agriculture sales decreased 31 percent from \$3.018 million to \$2.071 million;
- Horticulture specialties, including ornamental plants, was the largest single category of farm sales with \$946,636 in 2007, equaling 46 percent of the total value of agriculture sales;
- Market value of field and forage crops, vegetables, fruits and nuts, horticultural specialties, hogs and pigs, and livestock products increased, while sales and value of cattle and calves decreased;
- The number of cattle and calves decreased by 65 percent, from 2,223 to 776; the number of chickens decreased by 62 percent, from 1,830 to 699;
- Irrigated farmland decreased 47 percent, from 456 acres to 243 acres;
- Hired farm labor expenses decreased by 42 percent, from \$853,054 to \$499,069.

Caribbean Region

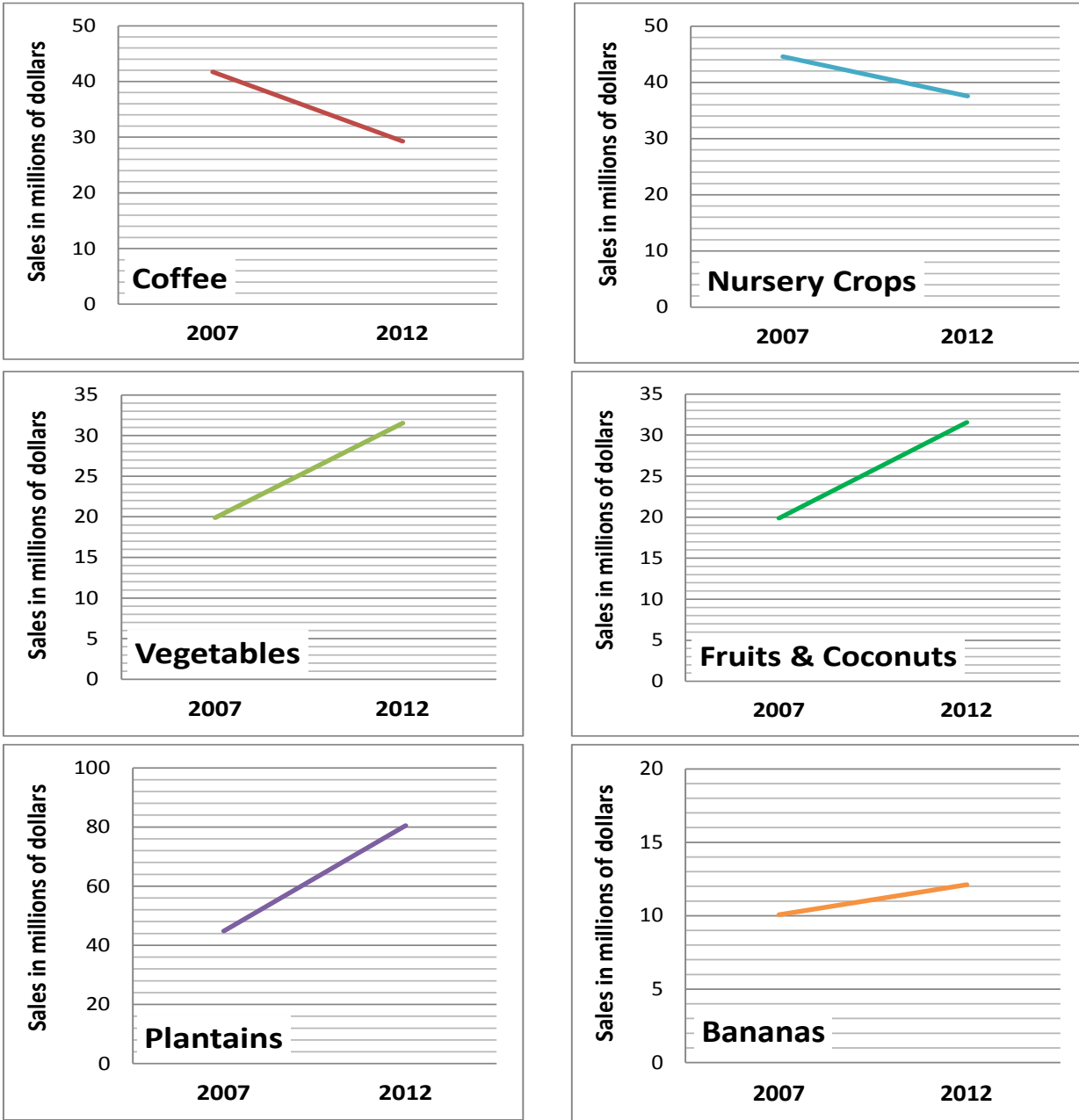

Figure 5: Market value of agricultural products sold in Puerto Rico in 2007 and in 2012 (National Agricultural Statistics Service, 2009b, 2014a)

1.3 Caribbean Climate Vulnerability

The Caribbean has been deemed especially vulnerable to the effects of climate change due to the region’s exposure to extreme weather events, its geographic and economic scale, and its reliance on tourism and imported goods (Barker, 2012; Gamble et al., 2009; Lewsey et al., 2004; Mimura et al., 2007; Puerto Rico Climate Change Council, 2013). The effects of predicted climatic shifts on working land systems vary to a large extent based on regional and site specific environmental and social factors. Environmental factors

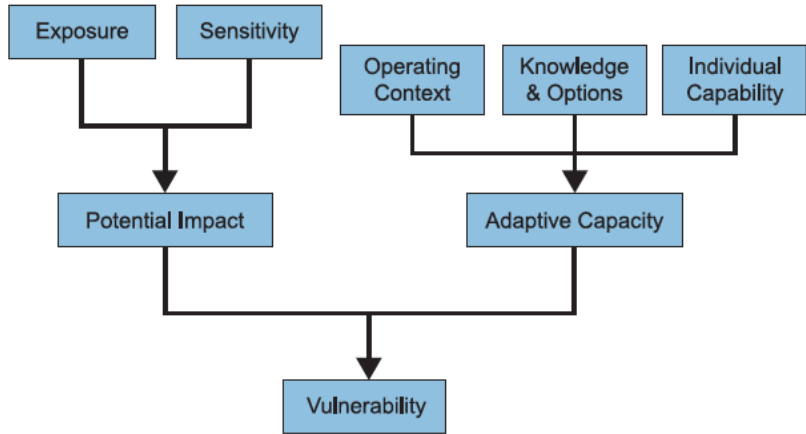

Figure 6: Components of vulnerability from Marshall (2010)

include mean temperature and precipitation shifts, changing diurnal extremes, changing seasonality, extreme weather events, increased carbon dioxide (CO₂) levels, hydrologic changes, and the subsequent effects on flora and fauna physiology and interactions. Social factors encompass socio-economic, political, cultural, and other human dynamics in which these environmental changes are occurring, including regulatory economic factors that affect how regional residents are able to respond and adapt to changing conditions. A combination of environmental and social conditions can be used to gauge the vulnerability of a given community or sector in the U.S. Caribbean, such as agriculture (Adger, 2006; Marshall, 2010; Walthall et al., 2012) (Figure 6). System disturbances include environmental disasters, economic downturns, supply chain failures, public health crises, political conflict, or upheaval, or a number of other events. Often these stressors precipitate or build on each other in what can become a system-wide negative feedback loop (Holling, 1973). Because these stressors can and do vary considerably across time and space, it is important for vulnerability assessments and subsequent actions to be timely and based on a combination of social and biophysical knowledge.

The U.S. Caribbean region represents a unique social-ecological system within the greater United States. Working lands in this region face some environmental challenges that are generally similar to those within the continental United States, such as increasing temperatures, shifting rainfall patterns, increasing weather variability and extremes, and rising sea levels. But higher levels of exposure, higher sensitivity, and lack of adaptive capacity make Caribbean systems more vulnerable to the effects of these challenges.

Factors contributing to high climate change vulnerability among Caribbean populations include:

- Vulnerable food supplies (Barker, 2012; Gamble et al., 2009).
- Potential new vulnerabilities to pests and introduced species that affect humans, livestock, wildlife and plants (Barker, 2012).
- Human populations and the prime agricultural lands are predominantly located in coastal areas (Gould et al., 2008; López et al., 2001; Parés-Ramos et al., 2008). Responding to sea level rise and finding ways to adjust coastal hydrology are critical issues requiring focused social, ecological, and climate science expertise, as well as long-term engagement with many agencies and organizations.
- Population densities in Puerto Rico and the Islands that are among the highest in the United States, and there is limited available space for growth and migration (Martinuzzi et al., 2007).

- The number and type of endemic and endangered species are among the highest in the United States (Gould et al., 2008).
- Unemployment and poverty levels are among the highest in the United States, and climate change represents an additional threat to rural economies.
- Of the 15,745 farms in Puerto Rico, 13,958 are individual or family owned and 575 are held by corporations (National Agricultural Statistics Service, 2009a). As a result, the majority of farms do not have the capacity for specialized research on adapting to climate change. Only 2,590 farms have crop insurance coverage and 10,628 farms have a net household income of less than \$20,000 (National Agricultural Statistics Service, 2009a) leaving many Puerto Rico farmers extremely vulnerable to the socioeconomic risks associated with climate change.

2. Regional Agriculture’s Sensitivity to Climate Change and Adaptation Strategies

This report provides an initial assessment of the major cropping systems, livestock, forestry, and related socio-economic factors in Puerto Rico and the U.S. Virgin Islands and their vulnerability to predicted climatic shifts associated with global climate change. Primary features of climate change affecting crop growth and yield are increased CO₂ levels, shifting seasonal weather patterns, and increased variability in temperature and precipitation. There is widespread agreement in the current literature that these factors interact with each other in varied, dynamic, and region-specific ways. However, more local studies are needed within Puerto Rico and the Virgin Islands to inform planning and infrastructural investments for increasing productivity and sustainability, and to insure the continued viability of Caribbean working land systems.

2.1 Cropping Systems Overview of Risks, Vulnerabilities and General Adaptation Strategies

Vulnerabilities for major crops, including coffee, grasses, fruits and vegetables, livestock (cattle), and forests are summarized for a set of seven broad climatic effects (Table 2) and discussed in detail by sector.

Table 2: Summary of major crop or other sector vulnerabilities.

Climate Effect	Coffee	Grasses	Specialty crops (Fruits and Vegetables)	Livestock	Forestry
Floods/Intense precipitation, sea level rise	Timing and amount of precipitation important to phenology of coffee. Negative effects of increased erosion and nutrient loss.	Some major range grass species intolerant to prolonged flood conditions.	Increasing extreme precipitation events may require additional cover crops, terracing, and other erosion controls. Timing of rain important in spread of pests and in productivity.	May affect hay, feed quality, costs, and availability.	Likely to affect coastal forests. Increased seasonality coupled with cyclonic storm effects may force directional changes in forest regeneration pathways.

Caribbean Region

Climate Effect	Coffee	Grasses	Specialty crops (Fruits and Vegetables)	Livestock	Forestry
Drought	Drought and unfavorable temperatures impede coffee production.	Selection for drought tolerant species. Fires may have greater negative effect. Overall decrease in range quality.	Drought tolerance varies by crop. Prolonged drought conditions will require additional investments in irrigation infrastructure. Research being conducted on drought tolerant cultivars.	Affects hay quality, feed cost, and availability, reduced productivity on grazing lands, and increased susceptibility to fire on grazing lands.	Increases in the intensity and length of droughts and increased wildfires are a serious concern in dry forest communities. Also likely to affect fruiting, phenology, and productivity.
Temperature shifts	Highly susceptible to increases in extreme temperatures.	Research needed to model species' responses to predicted temperature/precipitation shifts.	Higher temperatures can lead to increase in use of pesticides	Higher temperatures increase heat stress and reduce productivity	All forest types are likely to see alternations in flowering, fruiting phenology and survival of seedlings.
Intensified pest, weed, and disease outbreaks	Coffee Berry Borer (<i>Hypothenemus hampei</i>) introduced to Puerto Rico in 2007. Increases in temperature could support population spread and growth	Noxious weeds can spread and crowd out desired grass species.	Some pesticides (pyrethroids and spinosad) that are key to protecting perennial specialty cropping systems have been shown to be less effective in higher temperatures.	May directly or indirectly affect livestock by reducing quality and quantity of grazing lands.	Increasing stress and mortality.
Socio-economic	Labor shortages have a negative effect. Global shifts in weather patterns and pest distribution could have profound effect on market availability and competition, may have positive or negative effects.	Few examples or prototypes of resilient grazing practices available locally.	Marginal farms ill-positioned to make adaptive investments.	Lack of oversight and regulation in the cattle industry, small-scale production, and marketing, high land values, and low cost of imported meat favors imported over local meat. High cost of feed affects economic viability of local production.	Altered quantity and quality of forest ecosystem services (e.g., provision of clean water, carbon storage, economic and recreation opportunities).

Climate Effect	Coffee	Grasses	Specialty crops (Fruits and Vegetables)	Livestock	Forestry
Extreme Weather Events	Very susceptible to hurricane damage and lengthy damage recovery time.	Prolonged flooding problematic for some species.	Long re-establishment times post storm damage	Small-scale producers have low capacity to prepare for and respond to extreme weather events that directly affect livestock or indirectly affect costs and infrastructure.	Very susceptible to hurricane damage; forestry operations have little capacity to prepare for and respond to extreme weather events that directly or indirectly affect costs and infrastructure.
Additional Climate Features	Shifts in seasonality of rainfall events and temperature may affect distribution of pests and phenology of plants.	Salinization of coastal soils could have strongly negative effects. Some productivity models show increase in production with warmer climate, and CO ₂ enrichment.	Combination of CO ₂ fertilization and increased photosynthetically active radiation (PAR) availability shown to increase yields in some fruit trees.	Water availability and cost are important considerations that are likely to be affected by climate change.	Effects on cloud condensation will affect forest communities at the highest elevations.

Coffee

Coffee was first introduced to Puerto Rico in 1736 and superseded sugar cane in the late 19th century as the island’s chief agricultural export product. As Puerto Rican coffee was becoming a sought after commodity in Cuba and much of Europe around the turn of the twentieth century, a series of hurricanes and the loss of favored trade status with Spain resulted in a general industry-wide decline (Dietz, 1986). In an effort to reverse this trend and increase yields, the University of Puerto Rico Agricultural Extension Service conducted a series of studies during the 1940s and 1950s and found that decreasing tree cover and shading of coffee farms could increase yields (Abruna et al., 1959; Arrillaga & Gomez, 1942). Subsequently, intensive full sun techniques were encouraged throughout the 1960s and 1970s but failed to gain significant traction until the 1980s. Figure 7 shows how from 1982 to 2007, shade-grown coffee production declined by 70 percent

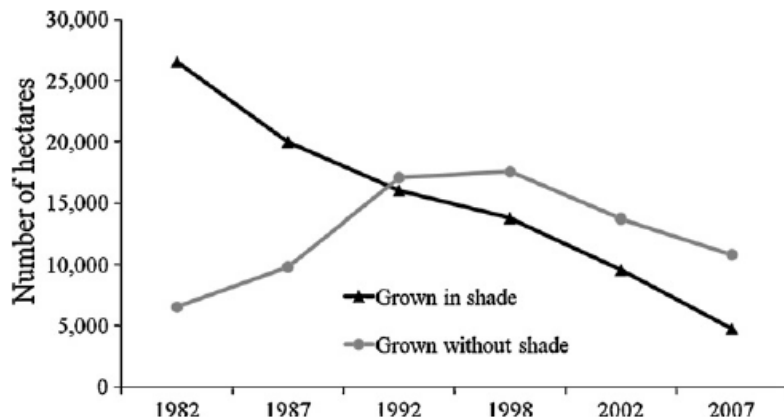

Figure 7: Number of hectares devoted to coffee grown in shade vs. full sun
 Source: (Borkhataria et al., 2012).

(Borkhataria et al., 2012). This strategy appeared to be effective as coffee became the most economically important crop in Puerto Rico from 1982 to 1998, accounting for 24 to 32 percent of the total agricultural market value (Borkhataria et al., 2012). However, this shift in cultivation practices significantly increased the crop's vulnerability to nutrient and soil loss as a result of runoff, wind damage, and landslides during severe storm events (Philpott et al., 2008). This vulnerability was demonstrated in 1998 when Hurricane Georges heavily damaged much of the island's coffee growing region.

By 2002, coffee had declined to only 16 percent of total agricultural market value, increasing slightly to 19 percent in 2007. The total value of coffee to the Puerto Rican economy peaked in 1992 at approximately \$56.8 million, and then declined to \$42 million by 2002. In 2007 it was valued at approximately \$41.8 million (Borkhataria et al., 2012; National Agricultural Statistics Service, 2014a). According to the NASS 2012 Census of Agriculture (2014a), the total number of coffee farms in Puerto Rico peaked in 1992 at 11,263, decreasing to 10,441 farms in 1998 and down to 4,478 farms by 2012. This steep decline may indicate the inability of many farmers to recover from Hurricane George. The average amount of money generated per farm from coffee increased steadily between 1982 and 1998, declined slightly in 2002, and then increased by 59 percent over the next five years. The 4,478 coffee farms in Puerto Rico in 2012 generated \$29,273,215 of income, representing approximately 5 percent of total agricultural market value that year (Borkhataria et al., 2012; National Agricultural Statistics Service, 2014a).

Environmental Vulnerabilities

Coffea arabica is the primary coffee species grown in Puerto Rico, and thrives in mean annual temperatures ranging from 15°C to 22°C (59° - 72°F). Temperatures above 23°C (~74°F) can result in accelerated flowering and loss of quality, while prolonged exposure to temperatures above 30°C (86°F) can lead to growth abnormalities and severely stunted growth (Damatta et al., 2006). Annual precipitation of 1000 mm (~40in) is generally considered a minimum for Arabica cultivation, with precipitation distributed over the course of the growing season. A dry period of 3-4 months is required to break bud dormancy and trigger the reproductive growth processes. Flowering usually coincides with the onset of rains, and subsequent fruiting and flowering is very dependent on available soil moisture. *C. arabica* evolved in the Ethiopian highlands as a shade tolerant, under-story plant. For a more in depth discussion on the physiology of *C. arabica* please see Obso (2006).

Climatic extreme events, such as droughts, floods, frosts, and heat waves can negatively affect coffee production. Drought conditions or heat waves during summer months can diminish the quality of the product or even translate to important losses in overall yield (Damatta et al., 2006; Gay et al., 2006). Climate models predict an increase in intense storms, hurricanes, and drought conditions within the eastern Caribbean, which could result in increased exposure levels for the already vulnerable coffee industry. Coffee production in Puerto Rico has been historically susceptible to hurricane and tropical storm damage (Borkhataria et al., 2012; Dietz, 1986). Coffee development requires a dry period during the onset of the spring season. However, a persistent dry spell or heavy rains during this season can spoil the flowering stage (Damatta et al., 2006). A study conducted at the University of Puerto Rico by Harmsen et al. (2009) found that the projected 20-year average September precipitation excess increased for all greenhouse gas emission scenarios and locations from 121 to 321 mm (4.7 – 12.6 in) between 2000 and 2090. Conversely, the projected 20-year average February precipitation deficit changed from -27 to -77 mm (1.06 – 3.03 in) between 2000 and 2090. Studies are needed correlating how this projected change precipitation distribution may affect coffee phenology and site selection in Puerto Rico.

The Coffee Berry Borer (*Hypothenemus hampei*) is one of the most important biological threats to coffee production worldwide. Jaramillo et al. (2009) determined the thermal tolerance of *H. hampei* (20-30°C) and predicted that even a temperature increase of 1°C could lead to considerably more rapid insect development and, more generations per fruiting season. The same study showed shifts in the pest's

latitudinal and altitudinal range under more dramatic temperature increases. The best strategy for slowing the expansion of *H. hampei* is to plant shade trees, which can reduce ambient temperatures by as much as 4°C. Such a reduction “would imply a drop of 34 percent in the intrinsic rate of increase of the coffee berry borer” (Jaramillo et al., 2011). A two-year study of shaded and unshaded coffee plantations in Kenya showed that *H. hampei* infestations levels in the shaded plantation were consistently lower than the sun-grown coffee (Jaramillo et al., 2011). During a roundtable discussion held in 2015 at the University of Puerto Rico, various industry experts gathered to discuss the state of the coffee industry in Puerto Rico. Much of the conversation centered on the threat of the Coffee Berry Borer and controls that have been found effective to date. The fungus *Beauveria bassiana* was presented as a potential bio-insecticide for the borer and a way to combat the pest without using harmful pesticides.¹

Socio-Economic Vulnerabilities

Coffee growers within the U.S. Caribbean face socioeconomic challenges, including global competition, limited operational resources, and labor shortages that affect producer resilience to changing conditions.

Limited Resource Farmers

Coffee plantations are a long-term investment for many farmers. Plants can require 3 to 6 years to reach productive maturity. The majority of Puerto Rico’s coffee producers are small-scale, limited resource farmers who may have few options for employing adaptive practices. Moving to another area, changing to specialty coffee, or cultivating another crop are long-term investments that may not be economically feasible for many growers (Gay et al., 2006). These economic constraints to modifying production practices represent a lack of social adaptive capacity. Marginally profitable farms have struggled to recover from storm damage because of long lag times between replanting and recovery of pre-storm yield levels (Borkhataria et al., 2012; Dietz, 1986).

¹ For more information see: <http://www.konacoffeefarmers.org/wp-content/uploads/2012/06/Balancing-pest-risk-with-cost-of-control-when-using-Beauveria-for-CBB-June-7-Hollingsworth-for-KCFA.pdf>; http://www.academia.edu/5249392/Biological_Control_of_Coffee_Berry_Borer_in_Organic_Coffee; and http://www.ars.usda.gov/research/projects/projects.htm?ACCN_NO=409873

Puerto Rican Coffee Production Strategies and Opportunities in Response to Climate Change

Primary coffee varieties

- *Coffea arabica* = Typica, Bourbon, Caturra, Pacas, Limani, Frontón, Catuai.
- *Coffea canephora* = Robusta
- *Coffea liberica* = Excelsa

Primary localities affected

- Adjuntas, Lares, Utuado, Jayuya, Maricao, Yauco, San Sebastián, Las Marias, Orocovis, Ciales.

Changes in climate

- Increasing temperatures, particularly in high-elevation areas;
- Long droughts punctuated by intense rainfall and floods;
- Water deficits and heat stresses;
- Increase in extreme weather events/hurricanes with intense winds;
- Shifts in seasonal rainfall patterns.

Climate effects

- Heat stress lowers production and reduces bean yields;
- Extreme and atypical rainfall events lower crop yields;
- Higher temperatures reduce photosynthesis, reduce growth, accelerate fruit senescence, limit fruiting, affect plant longevity, support Coffee Berry Borer populations;
- Increased rainfall and moisture may lead to coffee rust outbreaks, nitrogen deficits, reductions in plant growth and accelerated fruit fall;
- Drought can cause nutritional deficiency in soils;
- Quality of coffee might be diminished;
- Coffee shortages could increase market prices for consumers;
- Changes in temperature and rainfall could reduce available land suitable for coffee cultivation, including the loss of land currently highly suitable for coffee cultivation.

Adaptive strategies

- Shade grown coffee production can reduce high temperatures, reduce management costs, increase profits through crop diversification, increase nitrogen fixation, and reduce the need for fertilizer. Plant temporary and permanent shade (i.e., guaba, guineos, moca, platanos, gliricidia, gandul);
- Improve soil health with cover crops, manure, and crop residue recycling; use mulch to reduce soil temperature;
- In areas with increased rainfall, drain soil with contour ditches or diversion channels and regulate shade tree use;
- In areas with reduced rainfall, use permanent shade trees, and install infiltration trenches and individual terraces;
- Develop appropriate agroforestry and crop diversification management;
- Cultivate rust-resistant coffee varieties such as Limani, Frontón and Robusta;
- Use the fungus *Beauveria bassiana* as a bio-insecticide to control the Coffee Berry Borer pest;
- Shift location of production to higher elevation areas;
- Cultivate drought and heat-resistant varieties, and add irrigation;
- Establish windbreaks (i.e., macaco, hibiscos, bucaré enano) to reduce the effects of strong winds;
- Build local markets and platforms for knowledge sharing.

Opportunities

- Market demand exceeds production;
- Markets are increasing for specialty coffee products;
- New markets may develop to meet demands for organic, Fair Trade, or bird friendly production;
- Innovations in production and adaptive/climate smart demonstrations improve sustainable production and marketability of sustainable products;
- Shade-grown coffee provides a great marketing tool.

Labor Shortages

Labor shortages have been a persistent problem within Puerto Rico's coffee industry since its Spanish colonial roots. In recent years, estimates of lost crops due to insufficient labor have run from 30 to 50 percent of potential yield (Caribbean Business, 2014). Migrant labor forces predominantly of Dominican origin heavily augmented the labor force prior to the industry downturn after Hurricane George. During the time lag required to recover production, many of these migrant laborers left the region, which led to noticeable labor shortages around 2002. These shortages exist in the face of some of the highest unemployment rates in the United States of around 13 to 14 percent, (U.S. Department of Labor, 2013). A lawsuit filed by the U.S. Department of Labor against a major coffee grower in 2013 alleged violations of the Fair Labor Standards Act's minimum wage and record keeping provisions and highlighted industry struggles to comply with labor laws and meet production. Coffee pickers have traditionally been paid per pound of beans harvested, so inexperienced pickers can end up earning far less than the federally required hourly minimum. The Puerto Rican Department of Agriculture currently has a program to augment the wages of coffee laborers and in 2011 the Territorial Senate passed Bill 1038, which allows farmers anticipating labor shortages to hire foreign labor.

Market Opportunities

The global demand for coffee remains high and is growing. Among commodities, coffee has a monetary value surpassed only by oil. Its international trade generates over \$90 billion each year and involves roughly 500 million people throughout its supply chain from production to market (Damatta et al., 2006; Thurston et al., 2013). Current demand within Puerto Rico alone exceeds supply by almost two thirds, and the deficit is made up with substantial imports from Mexico and the Dominican Republic. These imports represent lost opportunities for Puerto Rican growers and room for substantial growth in the industry. Globally, coffee supplies are increasingly threatened by weather extremes, storm activity associated with climate change, and overall increased weather variability. Between 2009 and 2011, prices for *C. arabica* increased by 160 percent mainly because of dramatically reduced production levels in East Africa and Latin America, particularly in Columbia (Jaramillo et al., 2011). This situation has the potential to open new markets for Puerto Rican coffee exports, but the decline of the local industry can be reversed only if labor issues are solved and innovative and adaptive practices are adopted.

Adaptation planning needs

Modeling shifts in growing region/timing: There are currently no models that demonstrate how predicted temperature and precipitation shifts in Puerto Rico may affect local coffee production. Researchers could explore this issue using recently published downscaled climate data to model future shifts in phenology and potential growing regions.

Promoting shade-grown coffee to mitigate anticipated effects of climate change: Shade coffee systems have been demonstrated to have many benefits, including diversifying income sources for farmers, preserving water quality, decreasing plant susceptibility to heat stress and pests, preserving higher levels of bio-diversity, and protecting plants from extreme weather events (Borkhataria et al., 2012; Damatta et al., 2006). Much of Puerto Rico's coffee production takes place on steep hillsides that are prone to erosion under intensive cultivation practices. Incorporating crop trees into coffee systems stabilizes soil, reduces reservoir sedimentation, and can help recharge aquifers.

Grasses

When the United States took possession of Puerto Rico in 1898, 55 percent of the island was classified as pastureland (Dietz, 1986). As agricultural production declined throughout the island, much of the pasture and grassland that had been cleared by the Spanish for grazing and sugarcane production, transitioned into secondary forest. Alberts and Molinari (1943) provide excellent documentation and references for pasture

conditions and grass species distribution on the island in the early 1940s. By 2012, Puerto Rico had 554 farms harvesting grasses on 37,848 cuerdas (36,759 acres) from which it derived a market value of \$14,588,630 (National Agricultural Statistics Service, 2014a) (Figure 8). These numbers were up from the 2007 census which showed 406 farms harvesting on 36,041 cuerdas (35,004 acres) for a market value of \$13,372,308 (National Agricultural Statistics Service, 2009a).

Environmental Vulnerabilities

As recently as 1991, very few studies had been conducted on the potential effects of climate change on grasslands (Hall & Scurlock, 1991). Today, much of the current literature around climate change and grasslands is concerned with practices that increase carbon sequestration and nutrient retention in soils. The CENTURY model, developed by the Scientific Committee on Problems of the Environment (SCOPE) Project, has been used to model terrestrial biogeochemistry based on interactions between human management (agriculture, grazing, or other sources), climate, plant productivity, soil properties, and decomposition for a wide range of temperate and tropical grasslands (Parton et al., 1993). Using the CENTURY Model², Parton et al. (1995) investigated 31 temperate and tropical grassland sites and found that, with the exception of cold desert steppes, all sites experienced an increase in production and soil carbon retention. The authors have continued to use this ecosystem-based model in conjunction with the physiological-based model GRASS to predict the effects climate change may have on grasslands worldwide. Model results are sensitive to nitrogen (N) and precipitation inputs and fluctuations and are therefore specific to regional soil differences and varying management practices (Parton et al., 2014).

Item		2012	2007
Other vegetables or melons (including hydroponics)	farms	91	115
	cuerdas	152	246
	pounds	1,882,634	1,189,765
Nursery, greenhouse, floriculture and sod	farms	662	512
	cuerdas	2,842	3,057
Paragrass	farms	20	74
	cuerdas	(D)	1,677
Guinea grass	farms	167	137
	cuerdas	2,895	5,257
Merker grass	farms	3	29
	cuerdas	(D)	584
Pangola grass	farms	173	175
	cuerdas	7,491	8,855
Star grass	farms	45	67
	cuerdas	1,405	2,191
Pajón grass	farms	115	121
	cuerdas	8,644	11,608
Other dry hay	farms	72	(NA)
	cuerdas	9,878	(NA)
All grasses cut green for silage	farms	159	(NA)
	cuerdas	6,147	(NA)
All other silage - including corn and sorghum	farms	9	(NA)
	cuerdas	1,163	(NA)

Figure 8: Grasses harvested for sale: 2012 and 2007 (from National Agricultural Statistics Service, 2014a)

Studies conducted in greenhouses and controlled environments have found many plants respond positively to increased CO₂ levels by increases in biomass, photosynthesis, and yield. These responses are more pronounced among plants possessing C3 pathways for photosynthesis instead of C4 pathways. Major grass species within the Caribbean are predominantly C4 grasses. However, obtaining the positive effects of CO₂ fertilization can require more efficient water and fertilizer use to synchronize plant demand with the increased supply of CO₂. In addition, the benefits of increased CO₂ levels may be reduced or eliminated by the effects of climate change from increased temperatures and/or drought. These effects can result in lower levels of available soil moisture and nutrients, plant desiccation, heat stress, and

² The CENTURY model is a general model of plant-soil nutrient cycling which is being used to simulate carbon and nutrient dynamics for different types of ecosystems including grasslands, agricultural lands, forests and savannas. See <https://www.nrel.colostate.edu/projects/century/>

subsequent reduced yields and increased mortality (Izaurre et al., 2011; Karl, 2009). And while the overall quantity of biomass in grasses could potentially increase with higher CO₂ levels, pasture and rangeland forage quality generally declines from changes in plant N and protein content, which reduces the supply of adequate livestock feed. When forage protein levels decline, producers may need to lower stocking levels or increase their use of costly feed supplements (Karl, 2009). These supplements must be imported in the U.S. Caribbean at great cost to producers, which significantly contributes to the high cost of locally produced meat. Experiments and studies also demonstrate the dynamic and varied effects of increases in temperature, which may lengthen growing seasons, increase soil N availability, alter soil moisture content, and shift species composition and structure (Bertrand et al., 2008; Wan et al., 2005).

As with other major crops, there is a strong need for regional studies throughout Puerto Rico and the U.S. Virgin Islands to better understand how climate change might affect the production of grasses and grazing practices. The sector experienced a sharp decline in production from 230,652 tons in 2007 to 115,984 tons in 2012. Hardest hit were the Municipalities of Lajas, Cabo Rojo, Arecibo, Guánica, and Salinas. While the causes for the decline are varied and complex, extended rainy seasons followed by prolonged drought are heavily implicated. Unlike coffee and certain fruit trees, a shift toward more tolerant and resilient species such as star grass could be accomplished in a relatively quick and cost effective way, if changing climate conditions result in the need for these types of adaptations.

Socio-economic Vulnerabilities

Culturally accepted practices of overgrazing have surfaced as an issue in Puerto Rico and the U.S. Virgin Islands. In recent interviews and survey responses, advisors affiliated with the Natural Resource Conservation Service (NRCS), the University of The Virgin Islands, and the University of Puerto Rico expressed concern over lack of knowledge and/or adherence to sustainable carrying capacities. Within some areas of Puerto Rico, St. Croix, and St. Thomas, limited land availability and high land prices can drive landowners to exceed advisable stocking levels. These practices are strongly implicated as contributing to the overall degradation of Puerto Rico's watersheds and sediment accumulation in island reservoirs. Grazing management practices are often learned from prior generations within family operated farms or disseminated through cultural networks of farmers and ranchers. These traditional sources of information are extremely valuable, but are predicated upon historical analogues that may not optimize current or future environmental conditions or consider emerging social concerns such as water quality or carbon sequestration. Intervening in these knowledge-sharing networks can be difficult for 'outside' experts who may hold different value sets than local managers. Kristjanson et al. (2009) examined the effectiveness of various approaches and institutions in mobilizing scientific knowledge in order to inform sustainable management decisions in Africa. Some of their case studies involved intervention in traditional grazing practices in Tanzania. Building off a set of six propositions put forward by the Roundtable on Science and Technology for Sustainability of the U.S. National Academics, their case studies resulted in a list of seven recommendations. A United Nations Food and Agriculture Organization (FAO) study in Grenada on climate risk management in agriculture resulted in similar recommendations for *Good Agricultural Practices for Climate Risk Management*³ (Food and Agriculture Organization of the United Nations, 2008). Both studies make clear that farmers are more likely to incorporate management recommendations that are created through open, transparent, and participatory processes. The FAO report also found farmers were more likely to consider the adoption of best management practices that were already being implemented by farmers in their area. This represents an opportunity for researchers and advisors to positively intervene in traditional networks of knowledge sharing. Individual farmers may be offered incentives to demonstrate innovative grazing and management techniques to a broader community audience. The selection of the 'demonstration farmer' in this model is supremely

³ See http://www.fao.org/fileadmin/templates/tc/tce/pdf/Grenada_draft_final_report_May_2008.pdf

important, as this person must be someone who is trusted and commands respect within the community (Food and Agriculture Organization of the United Nations, 2008).

Pasture and Forage Production Strategies and Opportunities in Response to Climate Change

Primary Grass Crops

- Paragrass, Guinea grass, Merker grass, Pangola grass, Star grass, Pajón grass.

Primary localities affected

- Lajas, Arecibo, Cabo Rojo, Guánica, Hatillo, Aguada, St. Croix, St. Thomas.

Changes in climate

- Increased air temperatures;
- Increased drought conditions;
- Sporadic and extreme precipitation events.

Climate effects

- Heat stress;
- Desiccation;
- Reduced yields;
- Increased mortality;
- Limited amount of land available for forage production;
- Drought conditions result in decline in forage nutrients;
- As forage quality in pastures and rangelands declines with increasing CO₂ concentrations, more acreage will be required to provide livestock with the same amount of nutrients, resulting in an overall decline in livestock productivity.

Adaptive strategies

- Research alternative growing strategies and species;
- Shift toward more heat and drought tolerant species;
- Silvopasturing;
- Intercropping.

Opportunities

- CO₂ fertilization may prompt increased biomass production via increased growth rates and yields;
- Potential for bio-fuel production.

Adaptation planning needs

Changing pasture and grazing land management systems: Valuable new information could be derived from studies on how predicted temperature and precipitation shifts in the region will affect existing grass types and distributions, and the identification of species that could become desirable alternatives. Intercropping, silvopasturing techniques, and agroforestry practices may be useful strategies in attempting to capture the positive effects of increasing levels of available CO₂ and N while moderating ambient temperatures and moisture loss from evapotranspiration. However, extensive experimentation and demonstrations within the region may be necessary to effectively alter current practices.

Specialty Crops (Fruits and Vegetables)

The USDA classifies many of the major crops grown within the U.S. Caribbean region as ‘specialty crops.’ This classification includes most fruits and vegetables, as well as some root crops. These crops constituted many of the traditional food sources for the indigenous Taino peoples who pre-dated European settlement and for post-colonial Spanish populations. Widespread industrialization and the growth of the European middle class in the 19th century led to a sharp rise in demand for luxury

Caribbean Region

commodities such as sugar, coffee, and tobacco. Many of the small traditional farms on the island were aggregated to allow for mass production and export of these commodities. Because of this shift in cultivation, Puerto Rico and the Virgin Islands became increasingly dependent on imported food sources (Carro-Figueroa, 2002; Dietz, 1986). In 1830

subsistence crops such as plantains and sweet potatoes were still produced on over half of Puerto Rico’s agricultural lands, but sugarcane production was rapidly increasing (93 percent from 1812 to 1830). The cultivation of specialty crops continued to decline over the course of the 19th century, with correlating increases in food imports. Following the decline of sugar markets and the conclusion of World War II, a government led initiative known as ‘Operation Bootstrap’ sought to shift the economy of Puerto Rico from agriculture to light industry. This initiative contributed to a widespread abandonment of agricultural lands, urbanization, and reforestation of much of the island (Dietz, 1986). By 1988, much of the sugar industry throughout the Caribbean had collapsed and more than half of the former growing areas had transitioned back to dense forest (Grau et al., 2003; Thomlinson et al., 1996). More recently the Islands have begun to experience a renewed interest in specialty crop farming. The 2014 USDA Agricultural Census reflects growth in the organic farming and hydroponic sectors. As of 2012, the top three specialty crops by cuerdas⁴ were plantains, which were grown on 22,719 cuerdas (22,065 acres); oranges, which were grown on 8,759 cuerdas (8,507 acres); and vegetables, which were grown on 7,014 cuerdas (6,812 acres) (National Agricultural Statistics Service, 2014a).

Characteristics	Year		
	1949	1974	1997
Sugar cane	29.8	67.4	106
Coffee	7.1	8.9	7.2
Tabaco	7.8	2.2	---
Banana	1.3	3	3
Plantain	0.89	1.7	3.8
Tanier	0.7	1	1.5
Sweet Potato	0.9	0.83	2.5
Dasheen	0.6	0.8	1.45
Corn	1.6	1.3	7.6
Cassava	0.45	0.64	1.6
Pidgeon Pea	2.5	1.8	2.8
Yam	0.48	0.81	1.5

Figure 9: A historical comparison of average farm size (in cuerdas) across a selection of different crops, 1949 – 1997 (Carro-Figueroa, 2002).

Environmental Vulnerabilities

Climate change complicates food production from perennial crops, which comprise a large portion of specialty crops within the U.S. Caribbean. Perennial cropping systems are commonly in place for as long as 30 years. This poses a challenge in selecting the optimum cultivars for uncertain future conditions. Choosing the right cultivar is important when selecting for drought and pest tolerance. The development of new cultivars in perennial specialty crops commonly requires 15 to 30 or more years, greatly limiting the opportunity to quickly respond to changing conditions (Walthall et al., 2012). Studies have indicated that many fruit trees respond positively to increased CO₂ levels and moderate increases in temperature particularly when they coincide with an increase in photosynthetically active radiation (PAR) (Walthall et al., 2012). In some regions, increased atmospheric CO₂ has been shown to generally increase growth rates and yield, resulting in an increase in biomass accumulation and fruit production, and improved quality in fruit trees (Centritto et al., 1999; Idso & Kimball, 1997; Kimball et al., 2007). Over the long term, however, increased growth rates and yields may level off and begin to decline in the face of increasing temperatures and reduced soil nutrients (Adam et al., 2004; Druta, 2001; Pan et al., 1998; Vu et al., 2002; Walthall et al., 2012). Potential threats to specialty cropping systems include the proliferation of many pests following simultaneous increases in temperature and precipitation. However, overall warmer climates with small changes in precipitation during the growing season tend to maintain and eventually reduce the incidence of some diseases, unless an increase in precipitation occurs early in the growing season (Stöckle et al., 2010).

⁴ One cuerda = 0.971 acres

Specialty Crop Production Strategies and Opportunities in Response to Climate Change

Primary Crops

- Plantains, Bananas, Mangoes, Pumpkins, Oranges.

Primary localities affected

- Yabucoa, San Sebastián, Lares, Adjuntas, Salinas, St. Croix, St. Thomas.

Changes in climate

- Increasing temperatures and warming;
- Long droughts interspersed with intense rainfall and floods;
- Water deficits and heat stresses;
- Increasing extreme weather events/hurricanes with frequent and intense winds;
- Shifting seasonality of rainfall patterns.

Climate effects

- Heat stress/reduced yields;
- Warming and increased humidity could increase the incidence of pests, such as black leaf spot, known as black sigatoka, in bananas and plantains;
- Changes in disease distribution and severity; changes in disease vector ranges and behaviors;
- Emergence of new pests and diseases;
- Desiccation;
- Damage from extreme weather events;
- Salinization of soils and aquifers;
- Difficulty in planning/adapting.

Adaptive strategies

- Use of cover crops to improve soil health, including soil water holding capacity and infiltration;
- Integrate irrigation systems to avoid drought stress and reduce the incidence of pests associated with warming conditions;
- Improve soil health with integrated management practices such as no-till, use of manure and organic matter, and crop residue recycling;
- Improve pests and disease surveillance and monitoring;
- Greenhouse cultivation;
- Hydroponics;
- Aquaculture (e.g., the University of Virgin Islands Aquaponic System);
- Agroforestry practices.

Opportunities

- Increasing market for local products;
- Increase production to meet local demand and reduce the need for imported food;
- Improve information systems to pre-empt problems;
- Encourage adaptive/ climate smart demonstrations;
- Encourage innovation.

Socioeconomic Vulnerabilities

Many specialty crops within the U.S. Caribbean are perennial, including fruit tree crops such as avocados, mangoes, citrus, and others. In contrast to annual agronomic crop production, perennial crop production is not easily shifted to accommodate climatic changes. Many socioeconomic factors contribute to these constraints, including long crop re-establishment periods, travel times to processing plants, labor availability, and accessible markets. Small-scale producers have traditionally cultivated these crops on farms as small as 0.5 to 10 acres, and this scale of production is still common (Figure 10).

More recent statistics from the 2012 USDA Census of Agriculture indicate that the majority of Puerto Rico’s farms remain in the hands of small producers, although the number of small farms that are less than 10 cuerdas in size has declined significantly over the last ten years (Figure 10). Of the 2,579 farms in Puerto Rico classified by the USDA as

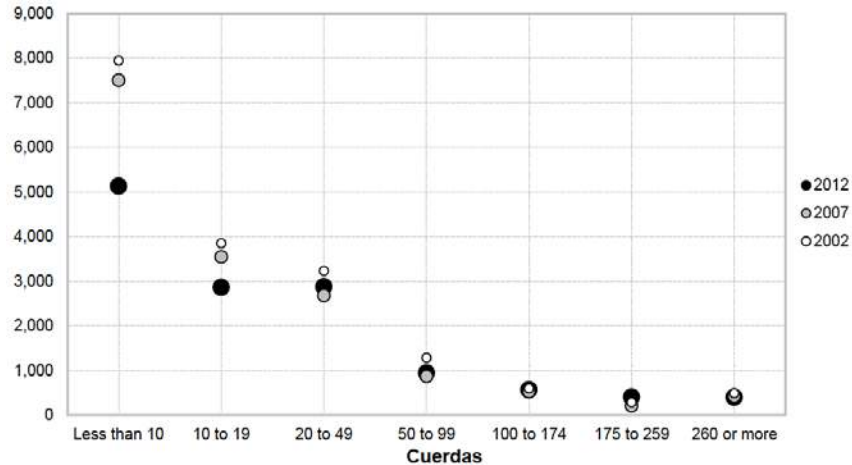

Figure 10: Puerto Rican farms by size (National Agricultural Statistics Service, 2014a)

growing fruits and coconuts, 2,268 of them were less than 10 cuerdas in size. In addition, most of them did not use irrigation--an important point to highlight, since small farmers may be less able to recover from storm damage or make adaptive investments in infrastructure and/or equipment.

2.2 Livestock Systems Overview of Risks, Vulnerabilities and General Adaptation Strategies

Cattle ranchers within the U.S. Caribbean are currently dealing with major challenges associated with the current drought, including the lack of available nutritional feed and needing to operate with limited resources.

Beef and dairy industry in Puerto Rico

The dairy industry is the leading agricultural enterprise in Puerto Rico and has been for the past four decades (National Agricultural Statistics Service, 2014b). From 1996 to 1997, the dairy industry was the most important agroindustry in Puerto Rico, with 425 dairy farms, three processing plants, and 90,000 milk or dairy cows that together generated over 28 percent (\$194 million) of agricultural sector revenues (Ramírez, 1998). For fiscal year 2009-2010, there were 330 dairy farms on the island that contributed \$215 million to the economy, which represents 26 percent of the gross farm income for that year (Ortiz, 2011). The dairy industry generates around 25,000 direct and indirect jobs, but despite its important role in the economy, it faces enormous challenges associated with high production costs, inefficiency herd management, poor nutritional programs, and low forage production (Ortiz, 2011). Overgrazing and the use of poor quality of pastures and grasses has forced farmers to rely mainly on imported and costly concentrated food to feed their animals.

The beef industry confronts serious challenges as well and has severely declined over the last decades. In 1950, Puerto Rico produced 23.2 million pounds of beef, which represented 74.4 percent of the total local consumption. The average per capita consumption was 14 pounds per person, according to the Puerto Rico Department of Agriculture Office of Agricultural Statistics. Beef imports began to increase dramatically in the 1960s. But the local production of beef started to decrease for the first time at the beginning of the 1990s, and during that decade, Puerto Rico imported more beef, relative to local production and population, than the U.S. mainland (Dewer et al., 1989). After the establishment of the farm-to-school program in 2000, there was a small increase in production that supplied local beef to school canteens. Since that time, local production has stabilized, but has not increased. In 2010, total beef consumption reached 156.8 million pounds, and only 17.2 million pounds (10.9 percent) were locally produced (Centro de Recursos Informativos Agrícolas de Puerto Rico, 2013). In 2012, production

declined to 15.5 million pounds. However, since the 1970s the per capita consumption of beef has remained stable at an average of 42.1 pounds per year (Centro de Recursos Informativos Agrícolas de Puerto Rico, 2013). The consumption of beef continues to be the center of the Puerto Rican diet. Meat and related products comprise 27 percent of local food consumption and represent the largest portion of food-related expenditures (Monclova, 2014a), compared to 24.7 percent spent on fruits and vegetables and 11 percent on dairy and related products. In 2011, the beef industry included 500 ranching families, employed about 4,000 people and accounted for 17 percent of the agricultural gross income, about \$30.1 million in 2008 (Araújo, 2011).

Beef and dairy industry in the U.S. Virgin Islands

The U.S. Virgin Islands have been known worldwide for its cattle industry thanks to the Senepol cattle breed, which was developed on St. Croix with traits suitable for livestock production in tropical climates. In the 1800s, N'Dama Cattle were imported to St. Croix from Senegal, West Africa. According to the Senepol Breeders Association, the N'Dama (a *Bos Taurus* breed), was well suited for the Caribbean because of its heat tolerance, insect and disease resistance, and its ability to thrive on poor quality forage. Previous attempts to import cattle from temperate regions failed due to heat and nutritional stress. In 1918, the red poll bull from Trinidad was brought to St. Croix by Bromley Nelthropp, whose father, Henry, was one of the largest breeders of the Senegalese cattle in the late 1800s (Pancham & Kossler, 2008). Genetic traits from the Red Poll breed were then introduced to the N'Dama stock to improve milking ability and fertility and to eliminate their horns (e.g., polled). This was the basis of the Senepol breed. The Senepol Association started in 1974 with four breeders, and by the 1980s cattle was being exported to Texas for breeding. Today Senepol cattle can be found in 21 states and around the world where there is a need for livestock that are adapted to tropical conditions.

However, in the past decades the number of senepols on the U.S. Virgin Island has declined. According to Hans Lawaetz of the Virgin Islands Senepol Association, this decline is a result of the high price of liability insurance, which has made St. Croix senepols less cost-competitive with livestock from smaller farms all over the world. As a result, St. Croix livestock farmers prefer breeding sheep and goats (Pancham & Kossler, 2008). For example, in the 1970s and 1980s, Annaly Farms sold 15 to 20 animals per week, but by 2008, sales had declined to 3 to 4 animals per week (Pancham & Kossler, 2008). The dairy industry of the U.S. Virgin Islands is also disappearing, particularly in St. Croix where Island Dairies (e.g., St. Croix Dairy Products) closed operations at the end of 2011 (Blackburn, 2011). In 2006, Island Dairies sold off all of its dairy cattle, closed down its milking operations and started manufacturing its products using dried milk-fat solids and frozen butterfat (Pancham & Kossler, 2008). A similar situation occurred with St. Thomas Dairies, which stopped adding fresh milk from its on-site cows after Hurricane Marilyn affected the island in 1995.

Vulnerabilities in the livestock sector in the U.S. Caribbean

One of the greatest challenges to dairy production in the Caribbean is heat stress (Ortiz, 2011). High temperatures and heat stress reduce the animal's productivity, and increases the proliferation and survival of parasites and disease pathogens. Warming reduces the ability of dairy cattle to produce milk and gain weight, and also lowers conception rates. The principal dairy breeds used in Puerto Rico and the U.S. Virgin Islands have been brought from temperate regions, so the higher temperatures anticipated from climate change might increase their vulnerability to chronic heat stress and reduce dairy productivity (Ortiz, 2011).

There are five "meat producing cores" in Puerto Rico and production is declining in all of them. According to the Comisión de Agricultura, Seguridad Alimentaria y Sustentabilidad de la Montaña y de la Región Sur, the lack of oversight and regulation in the beef industry over the past ten years has contributed to the disappearance of hundreds of livestock enterprises dedicated to raising beef cattle and is responsible for the bankruptcy of dozens of slaughterhouses around the island (Araújo, 2011). In 1984-

Caribbean Region

85 the USDA's Food Safety and Inspection Service reported that 20 plants were slaughtering cattle and calves in Puerto Rico (Duewer et al., 1989), but only four of these are still in operation today. USDA statistics indicate that the number of processed animal in Puerto Rico declined from 53,436 cattle in 2007-2008 to 36,993 cattle in 2011-2012. According to the Fund for the Promotion of the Beef Industry in Puerto Rico (Fondo para el Fomento de la Industria de Carne de Res en Puerto Rico) USDA grade A imported meat is more expensive than locally produced meat. Producers assert that local beef has a higher nutritional value since it is fresher and since it has a lower fat content because the animals are not castrated. Farmers also claim that the prices they receive for their cattle have been stagnant for the last 20 years. Farmers currently receive \$42 per arroba (quarter, or 66 pounds), but they state they should be receiving \$56.78 per quarter and are losing \$51.52 per animal (Araújo, 2011).

In 2014, the dry season in the U.S. Virgin Islands was drier than usual, and these conditions sparked wildfires that affected livestock and ranchers (Virgin Islands Department of Agriculture, 2013). The U.S. Virgin Islands Department of Agriculture (VIDOA) alerted livestock farmers that the dry weather could potentially damage their pastures and thus increase the risk for diseases and malnutrition since many of the farms were already affected by overgrazing. VIDOA stated that dry grass and brush do not supply the protein and energy needed by the cattle and indicated that farmers would need to provide protein in the form of grain, alfalfa cubes, hay, or by cutting young green tan-tan (Virgin Islands Department of Agriculture, 2013). Livestock is affected by dry weather and by wet weather and heavy rains. Dry weather makes livestock more susceptible to worms, ticks and other diseases, and dairy cattle becomes stressed and produce less milk, Molasses and corn can provide much needed energy as feed during dry weather but do not provide protein (Virgin Islands Department of Agriculture, 2013).

Livestock Production Strategies and Opportunities in Response to Climate Change

Primary livestock sectors

- Dairy and beef industry.

Primary localities affected

- Hatillo, Yabucoa, Camuy, Arecibo, Naguabo, San Sebastián, Lajas, Humacao, Isabela, St. Croix, St. Thomas.

Changes in climate

- Increasing temperatures and warming, continuous heat and humidity;
- Drought and longer dry seasons;
- Excessive rainfall in short periods of time;
- Increasing extreme weather events such as heat waves and hurricanes;
- Shifting seasonality of rainfall patterns.

Climate effects

- Thermal stress reduces animal productivity and increases mortality;
- Warming increases proliferation and survival of parasites and disease pathogens;
- Changes in rainfall distributions may lead to changes in diseases sensitive to moisture and relative humidity;
- Warming reduces the ability of dairy cattle to produce milk, gain weight, and reproduce; more daily stress hours reduce milk production and lower conception rates; milk production declines because of the increase in the number of days it takes for cows to reach their target weight;
- Warming lowers conception rates in beef cattle and reduces growth rates in swine;
- Warming increases water demands for animal needs and forage production;
- Warming increases animal housing costs (i.e., cooling systems);
- Warming may reduce pasture forage levels and quality;
- Excessively long rainy seasons reduce hay production;
- Climate changes may reduce the amount of land available for forage production;
- Drought conditions reduce forage nutrient quality which reduces the availability of good forage and increases grazing costs.

Adaptive strategies

- Changing livestock species as an adaptation strategy is a much more extreme, high-risk, and, in most cases, high-cost option than changing crop varieties;
- Selection of drought and heat-resistant livestock breeds, such as the "bald" Puerto Rican cow;
- Silvopasture establishment and crop diversification;
- Localized forage production and selection of nutritious grasses:
 - Star grass is drought-tolerant and resistant to most insects, but needs to be harvested or grazed on a regular basis to maintain optimal quality.
 - Aguja (needle) grass and Argentina bahia grass have shown tolerance to excess water and continued grazing.
 - Manure can be used to fertilize crops to increase forage yields and stocking rates.
- Modifying facilities to reduce heat stress on animals: adding shade trees; adding natural and artificial ventilation; and using cooling systems such as mist or fog systems and sprinkling systems;
- Developing more robust livestock breeds with enhanced adaptations to local climate conditions;
- Building local markets and platforms for knowledge sharing.

Opportunities

- Increasing production to meet local demand and reducing imports;
- Encouraging innovation and adaptive/climate smart demonstrations;
- Encouraging ranchers to provide ecosystem services to nearby farms such as invasive species control, fire hazard reduction, and pollination;
- Providing accurate predictions of climate trends and infrastructure and market development for the new livestock products.

2.3 Climate-related Vulnerability: Effects of 2014 drought on agriculture and livestock in Puerto Rico

The lack of rain during the first months of 2014 eventually led to drought conditions by May. The costs to Puerto Rico’s agriculture industry were estimated at \$20 million and affected about 4,000 farmers (Monclova, 2014b). According to USDA, about 2,541 livestock farms (28 percent of total livestock farms) were damaged by the drought, with sectors related to pastures, such as beef and dairy farms, cattle ranches and the coffee-growing industry being most strongly affected. The lack of rain reduced the availability of hay, which is the principal source of feed for cattle, goats, and sheep. This lowered livestock weights and overall livestock productivity, so farmers needed to buy costly imported concentrated feed. The area most affected by the drought was in the south, particularly the south-coast agricultural corridor and the Lajas Valley agricultural reserve, where 80 percent of the island’s vegetables are grown. The central coffee growing region was severely affected as well, as drought can reduce the size and quality of coffee beans (Damatta et al., 2006). USDA reported that 50 percent of the coffee farms (about 2,767 farms) were negatively affected by the drought. Overall, better than 50 municipalities were affected by abnormally dry or moderate drought conditions (Figure 11).

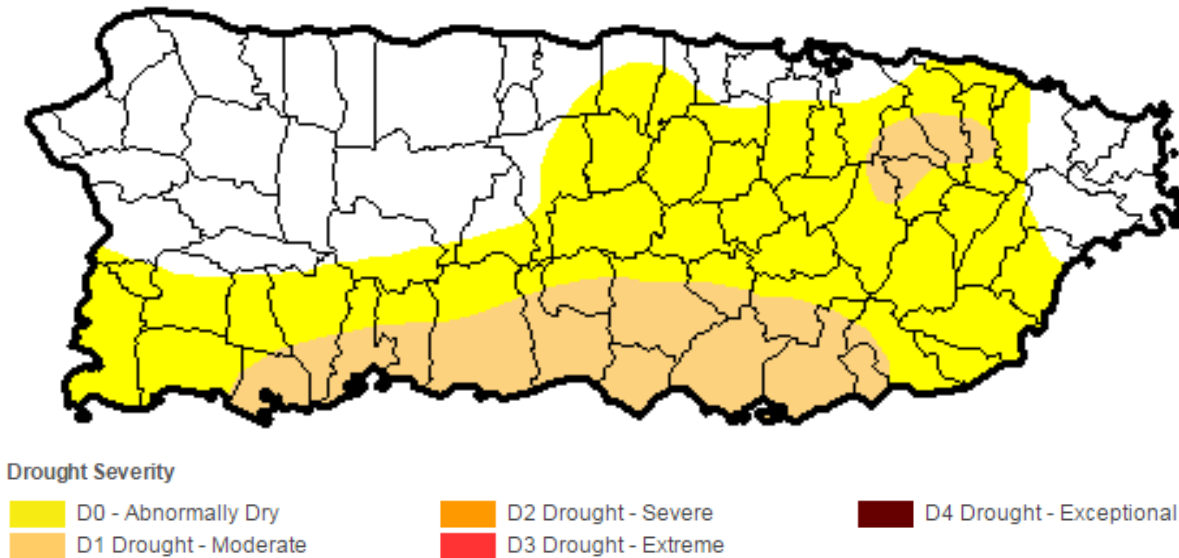

Figure 11: U.S. Drought Monitor - Statistics for Puerto Rico, July 29th, 2014.

(Source: <http://droughtmonitor.unl.edu/Home/StateDroughtMonitor.aspx?PR>)

NOTE: The U.S. Drought Monitor indicates local intensities range from D0 (abnormally dry, going into drought; short-term dryness that slows planting, crop or pasture growth, with above-average fire risk) to D1 (moderate drought, some damage to crops and pastures, with high fire risk; shallow streams, reservoirs or wells, with some water shortages developing or imminent; voluntary water-use restrictions requested).

Adaptation planning needs

Among the strategies identified by the Puerto Rican government to boost production and revive the beef industry are appropriating funds to continue the School Lunch Program, regulating the sales price for fresh meat, establishing a pilot cattle identification program, providing incentives for promoting artificial insemination and embryo transfer in cattle, and government agency purchases of Puerto Rican agricultural products. Small-scale production and marketing, high land values, and easy access to low-cost imported meat from Central America reduce the profits of Puerto Rican producers (Araújo, 2011; Duewer et al., 1989). In addition, heat, degraded lands, food shortages resulting from the cultivation of crops vulnerable to climate variabilities, and water shortages will likely affect the livestock industry in the U.S. Caribbean. Attempts to intensify production can inadvertently lead to infectious disease outbreaks by generally

diminishing sanitary conditions and increasing any given animals' exposure to others. These affects could in turn could have a negative effect on farmer productivity and increase consumer food costs.

3. Forest Systems Overview of Risks, Vulnerabilities and General Adaptation Strategies

Forests in the U.S. Caribbean consist primarily of broadleaf evergreen trees, with a mix of some 500 native and several hundred introduced species (Little & Wadsworth, 1964). Forest cover has gone through dramatic shifts from a pre-Columbian state of near total forest cover to deforestation at peak agricultural production in the 1950s, with a dramatic resurgence of reforestation after a wave of agricultural abandonment beginning in the 1950s and 60s (Birdsey & Weaver, 1987; Wadsworth, 1951) (Figure 12). Forest clearing in the 1800s and 1900s was primarily for agricultural purposes, but valuable timber was extracted for shipbuilding, construction, furniture, fencing, and as a source of charcoal (Dietz, 1986).

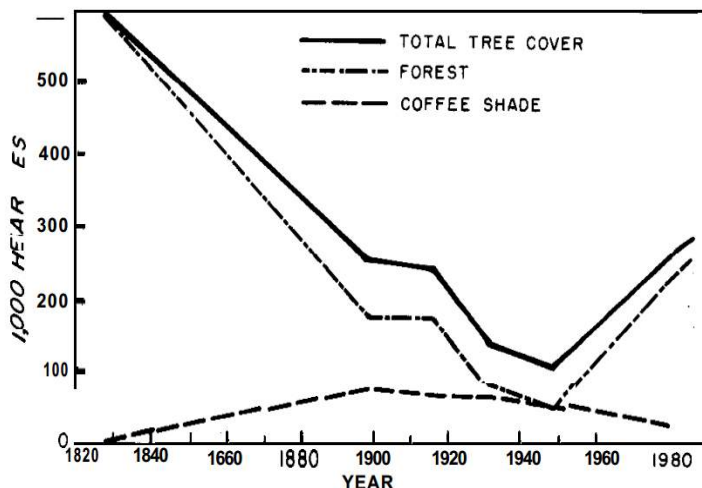

Figure 13: Forest loss and recovery over the last two centuries in Puerto Rico from (Birdsey & Weaver, 1987)

Currently more than half of the U.S. Caribbean archipelago is covered by forests, woodlands and shrublands that have become reestablished on abandoned farmland (Gould et al., 2008) (Figure 13). These forests are different from pre-Columbian forests, but have great potential for conservation, climate change mitigation, and use in modern forestry practices. Current forest cover structure and composition is principally governed by climate, substrate, topography and disturbance, along with forest age and management practices (or lack thereof) (Dansereau, 1966; Ewel & Whitmore, 1973; Gould et al., 2008; Gould et al., 2006; Helmer et al., 2002; Kennaway & Helmer, 2007; Lugo, 2005).

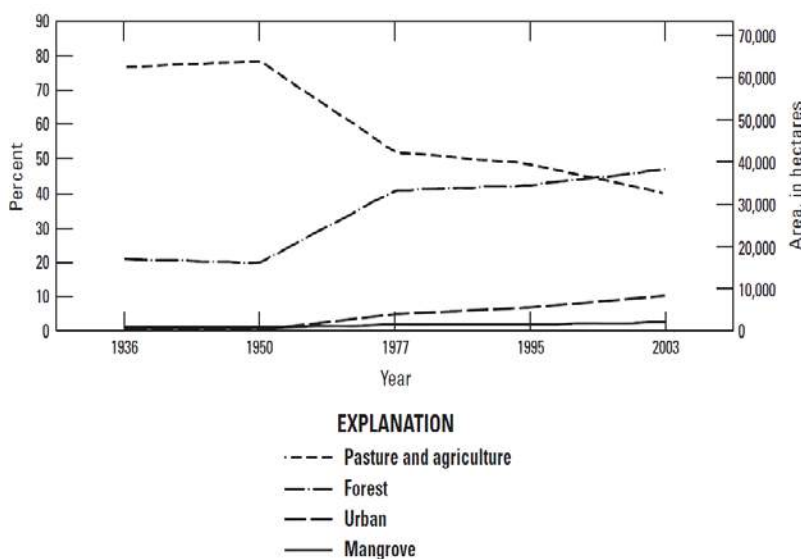

Figure 12: Resurgence of Forest cover in Northeastern Puerto Rico on abandoned pasture (Gould et al., 2012)

Little and Wadsworth (1964) described eight forest regions with distinctive climate and substrate that most likely defined the composition of original forests on Puerto Rico. A recent State of the Climate for Puerto Rico report (Puerto Rico Climate Change Council, 2013) assessed forest vulnerability to climate,

and in this assessment modern forest cover was categorized in four broad groupings as shown on Figure 14 (Nytch et al., 2013). This study was conducted to assess outcomes of changing climate stressors on the four forest categories shown on the map. Coastal Lowland Forests includes lowland moist forests and woodlands and freshwater Pterocarpus swamps and mangrove forests. Dry Forests includes forests, woodlands and shrublands in the subtropical dry Holdridge lifezone (Ewel & Whitmore, 1973). Karst Forests include the forests of the northern limestone region. Montane Forests include forests in the Central and Luquillo Mountains (Puerto Rico Climate Change Council, 2013).

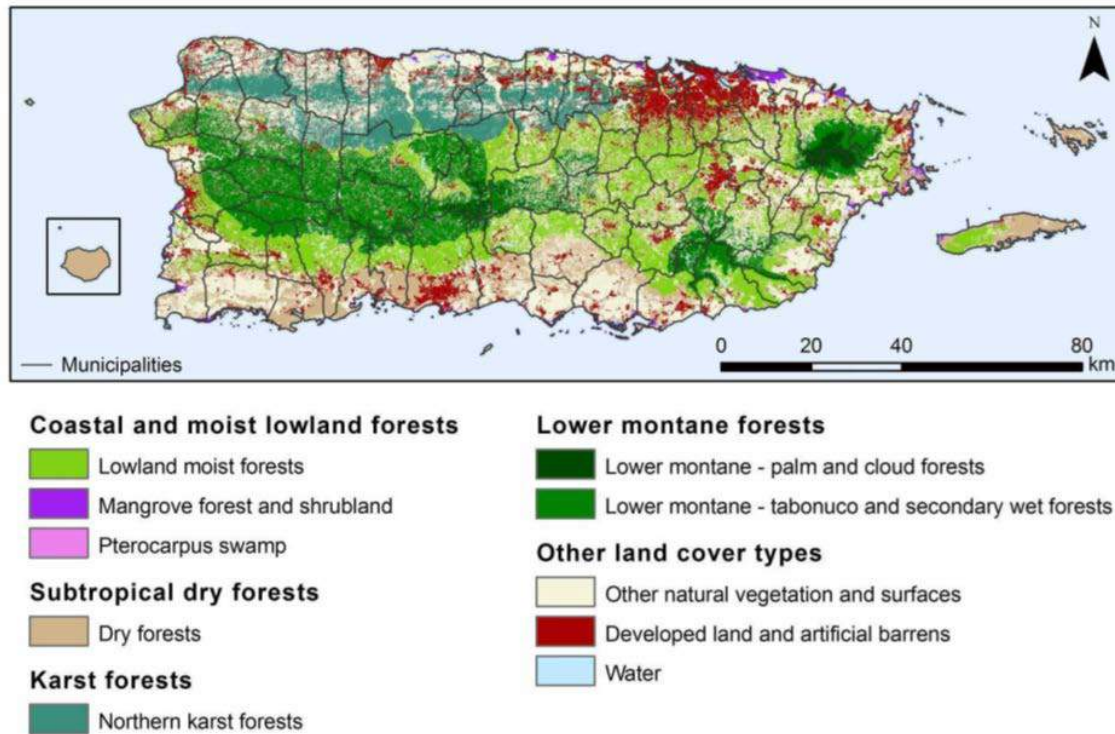

Figure 14: Four forest regions defined by climate and substrate (Nytch et al., 2013) based on (Gould et al., 2008).

3.1 Forest System Vulnerabilities

There is a long history of research on regional forest timber resources, tree species characteristics, and forestry practices (Briscoe & Wadsworth, 1970; Francis, 1995; Francis & Lowe, 2000; Little & Wadsworth, 1964; Wadsworth, 2000; Wadsworth, 1951, 1983; Wadsworth & Zweede, 2006). There is also a large body of research on ecological relationships of forest structure and function with climate related factors (Brokaw et al., 2012; Brown & Lugo, 1984, 1990; Gonzalez et al., 2014; Reagan & Waide, 1996). Nevertheless, the forestry sector in the U.S. Caribbean, much like the agricultural sector, is governed more by economic and social factors than climate. As in the agricultural sector, there is a renewed interest among government agencies and the public in revitalizing the timber and forest products industries as a way to improve local sustainability, economies, and quality of life. Climate adaptation, mitigation, and the relationship between forest cover and water resources is part of the public discussion and research scenario for the region. Four major climate change stressors that are likely to affect Puerto Rico's forests have been identified as 1) sea level rise, 2) increased severity of storms, 3) decreased precipitation, increased drought, and increased or changing seasonality, and 4) increased irradiation, increased mean temperatures and temperature extremes (Nytch et al., 2013). These stressors are predicted to have varying effects on the major climatic regions, forest cover, and associated forestry practices. Complex interactions among these stressors make it difficult to identify cause and effect relationships

among climate drivers and the effects on forested ecosystems. General conclusions about the anticipated outcomes and consequences are taken from Nytch et al. (2013):

- All forest types are likely to see changes in flowering and fruiting phenology. The establishment and survival of seedlings will be affected as well, which will result in changes in species composition, distribution, and abundance.
- Over the long term (decades), increased seasonality coupled with cyclonic storm effects will signal directional changes in forest regeneration pathways. This may ultimately lead to new communities that harbor unique assemblages of plants and animals, and exhibit altered forest structure and ecological functions.
- Biological communities located at the extremes of moisture, temperature, and elevation gradients – mountain peaks, dry forests, and coastal lowlands – are most at risk.
- Increased solar irradiation and temperatures, and their effects on cloud condensation, will affect forest communities at the highest elevations.
- Increases in drought intensity and length and increased wildfires are a serious concern in dry forest communities.
- Salt water intrusion will increase in coastal areas as sea levels rise and inundate low lying forests.
- Development pressures associated with population growth and expansion could further complicate the ability of lowland forests to adapt. Forested ecosystems also have cultural, historic, aesthetic, and economic values that will change in response to climate stressors.
- The delivery and flow of important forest ecosystem services may be compromised by climate-induced alterations, with potentially detrimental effects for the human communities that depend on them.

Adaptation planning needs

To some extent both the private sector and government agencies see value in supporting increased utilization of timber as a beneficial sustainable resource, but there is very little integrated organization, planning, or support for this increased use. Timber production could be conducted using diverse but limited land and water resources, but must compete with other planned and unplanned land uses. Planning is urgently needed for strategies that integrate conservation, water management, recreation, agriculture, and development for timber and non-timber wood resources and that incorporates future climate scenarios into these strategies. This would optimize the use of available information about the history and practice of tropical forestry, optimize opportunities to produce high-value wood products unique to the region, introduce new technologies in remote sensing characterization and forest resource monitoring, and integrate newer technologies and practices associated with collaborative landscape planning.

Forest Production Strategies and Opportunities Response to Climate Change

Primary wood resources

- There are a large number of native and nonnative tree species capable of providing wood products and other benefits such as erosion control, habitat improvement, water and nutrient retention. Species characteristics range from slow growing, high value specialty woods, to fast growing species capable of high productivity in diverse climates and soil conditions.

Primary localities

- Region-wide, with specific species and productivities governed by climate and soil characteristics. Forest cover and forestry practices are strongly tied to watershed characteristics and the amount and condition of runoff, stream flow, erosion and sedimentation. Key considerations in forestry (where and how much forest cover is optimal, are the locations of aquifer recharge areas, reservoirs, and estuarine and marine resources such as coral reefs.

Climate effects

- Alternations in flowering and fruiting phenology.
- Changes in seedling survival.
- Changes in species composition, distribution, and abundance.
- Increased seasonality changes in cyclonic storm effects:
 - Directional changes in forest regeneration pathways,
 - New communities - unique assemblages of plants and animals,
 - Altered forest structure and ecological functions.
- Effects on cloud condensation will affect cloud forest communities at the highest elevations.
- Increases in the intensity and length of droughts and increased wildfires will affect dry forest communities.
- Salt water intrusion and sea level rise will affect low lying forests.
- Biological communities located at the extremes of moisture, temperature, and elevation gradients – mountain peaks, dry forests, and coastal lowlands – are most at risk.

Adaptation strategies

- Improved marketing and resource use strategies.
- Better utilization of existing silvicultural knowledge.
- Use of spatial analyses to integrate forest resource use with other land use options.
- Incentives to increase productive forest lands.
- Integrating forestry and agriculture through practices such as silvopasturing and agroforestry

Opportunities

- Salvage market: currently high value woods are unused or lost to waste stream.
- Stewardship programs: providing support for silviculture and agroforestry.
- Global markets and added value products: Local timber developed into high value products that can be marketed globally.

4. Additional Socioeconomic Factors Contributing to Regional Vulnerability

Confounding socioeconomic factors make the U.S. Caribbean particularly vulnerable to a changing climate, including: 1) planning, infrastructure, and production costs; 2) high energy costs; and 3) food supply chain vulnerabilities.

4.1 Issues of agricultural planning, infrastructure and production costs

The island of Puerto Rico has a total land area of 2,274,528 cuerdas (around 2.2 million acres). Nearly 45 percent of the island, or about 1,042,974 cuerdas (1,011,685 acres), are classified as Agro-Ecological Zones (AEZ) by the NRCS due to their high agricultural value (UPRM, 2006). Of the agricultural lands classified as AEZs, only 91,000 cuerdas (88,270 acres) are protected or designated by law as Agricultural Reserves (UPRM, 2006). In addition to the agricultural reserves, the State Department of Agriculture has ~ 53,000 cuerdas (51,410 acres) classified as family farms and another ~ 67,000 cuerdas (64,990 acres) under the Lands Authority (“Autoridad de Tierras de Puerto Rico”), for a total of 211,000 cuerdas (204,670 acres) of agricultural lands administered by the government (Cordero-Mercado, 2014). This means that only 20 percent of the terrains classified as AEZ by NRCS are reserved for agricultural uses. The remaining land is available for urban, industrial, or commercial uses. The state law allows diverse uses in agricultural lands, including windmills and photovoltaic projects, which are competing for land resources and reducing the availability of agricultural land for food production. To assist the Department of Agriculture and the Lands Authority with the long-term agricultural planning, the Puerto Rico Planning Board has identified areas of high agricultural value and best sites for agricultural reserves (Figure 15).



Figure 15: Areas of high productivity or agricultural potential identified by the Puerto Rico Planning Board. These are low populated areas declared of high agricultural value. Soils in these areas are classified from I to IV, according to the Federal Conservation Service. Not all of them have been declared agricultural reserve by law.

Source: <http://gis.disur.org/datosgis/>

Of the total 361,542 cuerdas (351,138 acres) of land identified by the Puerto Rico Planning Board as areas of high productivity or agricultural potential, about 38 percent (137,386 cuerdas, 133,264 acres) are located in the north, 34 percent (122,924 cuerdas, 119,236 acres) in the south, 13 percent (47,000 cuerdas, 45,590 acres) in the east, 10 percent (36,154 cuerdas, 35,069 acres) in the west, and 5 percent (18,077 cuerdas, 17,535 acres) in the central mountain region (Figure 16). According to the Puerto Rico Products Association (APPR), agriculture must overcome tough structural challenges in order to become a productive sector, including high operational costs, low aggregated value, poor technology use and adoption, competitively-priced imports, and a limited agribusiness culture and innovation. Interviews and information gathering by the Caribbean Climate Sub Hub team indicate that land use planning processes

in Puerto Rico and the U.S. Virgin Islands may be problematic. Planners are appointed by sitting Territorial Governors with a correspondingly high turnover rate. Within the U.S. Virgin Islands, all land use planning measures must be approved by the entire Territorial Senate.

These and other such processes over-politicize planning and, to date, have created impediments in Puerto Rico for the completion of a comprehensive, island-wide land use plan. As a consequence, decisions often favor temporary economic expansion over long-term socio-ecological sustainability. This phenomenon can most readily be observed in the development and poor use practices within important watersheds on both island systems. Many of Puerto Rico’s reservoirs are operating at extremely reduced capacities because of high sedimentation rates caused by poorly planned and implemented development within their respective watersheds. Models that show general drying trends over the next several decades highlight the importance of comprehensive watershed management and the need to reconsider how land use policies and decisions are made throughout the U.S. Caribbean.

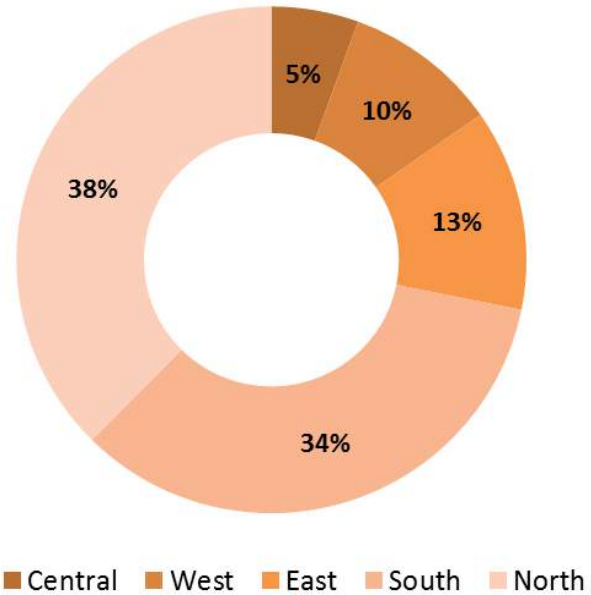

Figure 16: Distribution of arable lands within Puerto Rico

4.2 High production costs due to high energy costs

Like most other Caribbean islands, Puerto Rico and the U.S. Virgin Islands have no fossil fuel energy resources and rely on imports to meet their energy needs, including for electricity generation and desalination for the public water supply in the U.S. Virgin Islands. The cost of imported petroleum has driven Puerto Rico and U.S. Virgin Island electricity prices to more than twice the U.S. average (U.S. Energy Information Administration, 2013a). Puerto Rico’s electricity is supplied by the Autoridad de Energía Eléctrica (PREPA in English), a government agency that owns the electric distribution system. The majority (65%) of Puerto Rico’s energy supply is derived from petroleum. The balance of PREPA power supply is almost evenly divided between natural gas and coal generation, with a small fraction coming from hydroelectric generators. The U.S. Virgin Island’s economy is known to be nearly seven times more energy-intensive than the U.S. economy; according to the U.S. Energy Information Administration (EIA), per capita energy consumption in recent years has run as much as eight times higher than the U.S. average (U.S. Energy Information Administration, 2013b). Energy efficiency in the U.S. Virgin Islands is low because of water desalination requirements, the predominance of small simple-cycle generators, and operational constraints and power losses on the islands’ isolated electric grids. Currently, agencies are exploring the potential for connecting the isolated island grids with each other and with other Caribbean islands to develop a Caribbean-wide grid that could lower costs and enable the use of more renewable energy (U.S. Energy Information Administration, 2013a).

Puerto Rico Territory Energy Profile (U.S. Energy Information Administration, 2013a):

- Puerto Rico has few conventional energy resources, and imported petroleum products are the dominant energy source for the island.
- In 2012, 65 percent of Puerto Rico’s electricity came from petroleum, 18 percent from natural gas, 16 percent from coal, and 1 percent from renewable energy.

Caribbean Region

- In 2010, Puerto Rico was fifth among U.S. states and territories in installations of solar thermal hot water heaters. Two wind facilities that began operations in 2012, the Santa Isabel and Punta da Lima plants, can supply about 120 megawatts at full capacity, although they were not functioning at full capacity at time of publication. Up to 30 billion kilowatt-hours (kwh) per year of electricity could potentially be generated by tapping ocean wave energy.
- Puerto Rico offers tax benefits to encourage installation of solar equipment and allows net metering, meaning that residents can sell power from home solar panels to the grid.
- Puerto Rico has adopted a Renewable Portfolio Standard mandating that 20 percent of net electricity sales must come from renewable energy resources by 2035.

U.S. Virgin Islands Energy Profile (U.S. Energy Information Administration, 2013b):

- The U.S. Virgin Islands has few conventional energy resources and depend on imported petroleum products for electricity generation. To increase grid reliability, the Virgin Islands Water and Power Authority has explored the technical feasibility of undersea cable links with Puerto Rico and the British Virgin Islands.
- As of January 2012, consumers in the Virgin Islands were paying an average price of 47 cents per kwh for electricity, compared to an average of 12-14 cents/kwh in the continental United States.
- The Virgin Islands' first large-scale solar project, the 451-kilowatt King Airport photovoltaic array on St. Thomas, went into operation in fall 2011 and provides 15 percent of the airport's electricity. A 4-megawatt solar facility is being built on St. Croix.
- The Hovensa refinery, which was one of the 10 largest crude oil refineries in the world and which provided 90 percent of the Virgin Islands' fuel, ended production in February 2012. The site will continue as a storage terminal.
- The Virgin Islands was the site of a pilot project of the international Energy Development in Island Nations (EDIN) program, which encouraged efficiency and the use of renewable energy resources to cut fossil fuel use 60 percent by 2025. The program has transitioned to a new community-focused campaign.

High energy costs have a detrimental effect on the ability of Caribbean farmers to compete both domestically and abroad as they contribute to high production costs and the subsequent high cost of locally produced agricultural goods.

4.3 Vulnerability of Food Supply Chains in Puerto Rico and the U.S. Virgin Islands

To ensure the long-term sustainability of agricultural systems and to reduce the vulnerabilities associated with climate change, there is a need to combine crop resilience with adaptation strategies that target all aspects of food production, including supply-chain security, water scarcity, infrastructure, and distribution, evolving consumer demands, and workforce stability (Walthall et al., 2012). Low agricultural production and high dependency on imported food can increase the vulnerability of island states to the effects of climatic variability, unexpected world events, and other external factors (Mimura et al., 2007)(Figure 17).

Following a transition in the U.S. Virgin Islands from sugarcane to citrus fruits, tamarinds, mangos, animal feed (sorghum), and vegetables during the 1970s and 1980s, agricultural activity has decreased considerably during the last several decades (Samuel & McEntire, 2011). Likewise, Puerto Rico’s agricultural sector currently contributes only 1 percent of the island’s GDP. The absence of a strong agricultural sector in

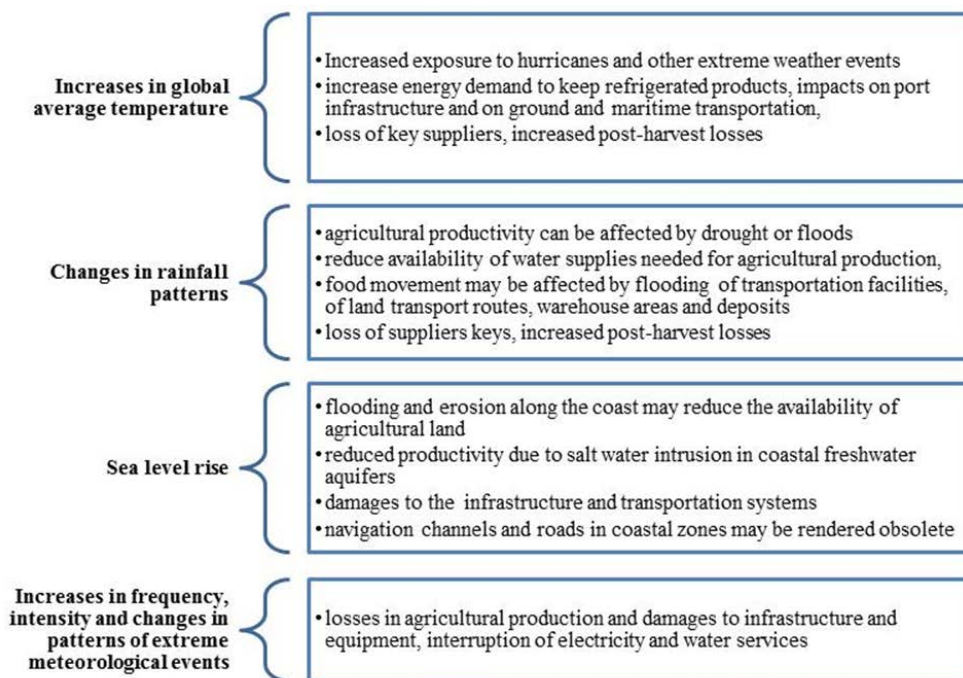

Figure 17: Vulnerabilities of food supply chains in Puerto Rico and U.S. Virgin Islands to climate change, considering farms located

these territories increases the risks of food insecurity and potential malnutrition. Food security is defined by four factors: availability of food, population access to food, usage of food, and stability of supply systems (Food and Agriculture Organization of the United Nations, 2014). Puerto Rico lacks security in these four factors (Comas, 2009). Puerto Rico imports 84 percent of its food needs, with the majority coming from the US (76%) (Comas, 2009). Puerto Rico imports almost all cereals, fats, oils, sugar, vegetables, legumes, and fish products (Comas, 2009). Most imports come from the United States through the Port of Jacksonville, Florida, which is located about 1,121 miles from the Port of San Juan, where 90 percent of the cargo for the island is received (Comas, 2009). Four maritime companies supply the bulk of transportation services between Puerto Rico and the United States, completing over 10 trips per week (Comas, 2009). This dependence on a limited number of companies increases the vulnerability of the food supply chain and increases the price of the food products due to high cargo fees and tight control over transportation and delivery services. This particular system increases the island’s vulnerability by having a single port of entry for products and a single mode of transportation, making the supply chain more susceptible to shocks and natural disasters. Similarly, the export industry of locally produced crops (most often mangos, coffee, and tomatoes), could also be potentially affected by these factors (National Agricultural Statistics Service, 2014a). Additionally, long food supply chains unduly contribute to climate change through greenhouse gas (GHG) emissions related to the production and transportation of products. The U.S. Virgin Islands also have a small agriculture sector, with 97 percent of food, medication, and fuel being imported (Alperen, 2006). Major piers within the territory have been deemed vulnerable to seismic activity and damage from tsunamis and/or tidal surges. Any damage to infrastructure and/or prolonged delays in food shipments could result in critical shortages on the islands (Alperen, 2006; CIA World Factbook, 2014) The Federal Emergency Management Agency (FEMA) Disaster Management Guide-U.S. Virgin Islands 2004⁵ indicates that due to the region’s high dependence

⁵ See <https://training.fema.gov/hiedu/downloads/compemgmtbookproject/comparative%20em%20book%20-%20chapter%20-%20in%20the%20u.s.%20virgin%20islands.doc>

on imported food, regional ports would need to resume normal operations within 1-2 weeks after a disaster to avoid severe depletion of island food supplies (Alperen, 2006).

Water Issues in Puerto Rico and the U.S. Virgin Islands

Water is potentially the most valuable and vulnerable resource within the U.S. Caribbean. Water management issues span geographical, institutional, and disciplinary boundaries, and necessitate contending with various demands and management paradigms. Despite these challenges, effective and comprehensive management is crucial to ensuring the viability of socio-ecological systems within the U.S. Caribbean. Water is a shared concern among interest groups and stakeholders that may otherwise view themselves as insulated from larger, landscape scale issues. Agricultural and forest management practices have a profound effect on water quality, but they have largely been shielded from Clean Water Act regulation due to their ‘non-point source’ designation. Despite this fact, land managers and advisors need to ensure that their operations align with recognized best management practices and are not unduly affecting public water supplies. Pollution from a variety of sources has had notable effects on ground, surface, and municipal water supply quality since the industrialization of the islands during the 1940s and 1950s (Hunter & Arbona, 1995). The Puerto Rico Office of the Governor Environmental Quality Board recognizes that “water pollution is detrimental to public health and welfare, creates public nuisances, is harmful to wildlife, fish and other aquatic life, and impairs domestic, agricultural, industrial, recreational and other beneficial uses of the waters” (Puerto Rico Environmental Quality Board, 2014). This statement highlights the need for a cooperative and integrated approach across the islands in the arena of water management and planning.

Issues of water quality and scarcity are already of great concern across the U.S. Caribbean region. Both Puerto Rico and the U.S. Virgin Islands have experienced a series of moderate to severe droughts within the last several years. In 1994, 1995, and again in 2015, severe droughts in Puerto Rico forced the government to implement water rationing and restrictions that affected millions of residents and businesses (U.S. Geological Survey, 2001). In the summers of 2014 and 2015, Puerto Rico experienced droughts that highlighted the precarious nature of its water supply in the face of high population densities, the potential effects of climate change and diminished storage capacity (Caribbean Business, 2014; Coto, 2014). Emerging climate models for the region predict an overall decrease in precipitation, but also point to greater variance in seasonal rainfall distribution, with an increase in intense precipitation events (Harmsen et al., 2009). Such shifts have the potential to prolong drought periods while also increasing erosion rates and threatening agricultural and municipal water supplies, as well as coastal ecosystems. The temporal and spatial distribution of rainfall can have profound effects on the hydrology of an area and may necessitate major adjustments in how working lands are managed by government planners.

Erosion and Agricultural Water Supply

Water is potentially the most valuable and vulnerable resource within the U.S. Caribbean. The humid, tropical environment and steep slopes in much of the central region of Puerto Rico make deforested areas particularly susceptible to erosion (Larsen & Román, 2013). Prior to industrialization, widespread deforestation for plantation agriculture resulted in frequent landslides and the accumulation of colluvial material (sediment) within watersheds throughout the country. The problem was exacerbated by increased land use pressure as the island’s population has expanded dramatically over the previous 70+ years. This accumulated colluvium erodes into streams over many decades, and larger episodic releases occur during intense rain events such as hurricanes and tropical storms (Larsen & Román, 2013). The process illustrates how land use practices can affect landscapes over the short and long-term and highlights the importance of comprehensive plans that are executed with future sustainability in mind. Currently, mean annual discharge of suspended sediments into Puerto Rican coastal waters is estimated at 2.7 to 9.0 million metric tons per year (Larsen & Webb, 2009). Storms and intense rainfall events play a disproportionately important role in this process; daily sediment discharge rates during such events have

been measured up to 3.6 times higher than annual means (Larsen & Webb, 2009). Among other negative effects, high sedimentation rates have led to lost storage capacity in Puerto Rico's reservoir system. This has limited the island's ability to adapt to periods of prolonged drought even as climate change may increase the need to do so. USGS monitoring revealed that 14 of Puerto Rico's public water-supply reservoirs had lost between 14 to 81 percent of capacity to sedimentation over the last ~50 years (López et al., 2001).

Within the Islands, farmers and the agricultural advisory community have indicated that water availability is one of their primary concerns. As can be seen by comparing mean annual rainfall (Figure 3), the Virgin Islands have a much more modest water budget than that of Puerto Rico. Many farmers rely upon the Virgin Islands Department of Agriculture to supply water to lands leased from the department. Farmers operating outside of the central valley region of St. Croix may rely on department trucks that deliver water to holding tanks. In addition, appropriate personnel are needed to monitor dam conditions located throughout St. Thomas and St. Croix. These dams and associated holding ponds serve a variety of purposes in Virgin Islands watershed systems. Slowing the flow of runoff allows sediment to settle out of turbulent waters and increases percolation times necessary to recharge vital aquifers. Much of the dam infrastructure was constructed under the Dutch and now needs repair, but there is little funding available for this purpose. Constructing, repairing, and maintaining these dams may provide a relatively low cost 'no regrets' strategy for decreasing the vulnerability of water supplies (and subsequently, food supplies) within the islands.

Sewage treatment plants constructed on St. Thomas and St. Croix in response to the Clean Water Act of 1972 have the potential to supply substantial amounts of water for agricultural uses. The St. Croix plant was constructed with an outlet where tanker trucks can access treated outflow (effluent) with the express intent of supplying agricultural needs on the island. On St. Thomas, the University of Virgin Islands campus is successfully irrigated with outflow from the treatment plant. This use represents only a fraction of the millions of gallons processed by the plants every day. Increasing the application of grey water and treated sewage may water managers with new strategies to maximize reduced water budgets. These strategies may also have beneficial effects on coastal and coral ecosystems, as such products have traditionally been piped to outflow points in coastal waters. Water infrastructure investments may need to be prioritized within the Virgin Islands and Puerto Rico in the face of climate change and associated potentials for shifting precipitation patterns.

Water Quality and Tourism

Tourism is a critical piece of the economies of both Puerto Rico and the U.S. Virgin Islands. Much of the tourism in the area is focused around beaches, pristine waters, and coral reefs that provide a quintessential Caribbean experience to the over 6 million tourists who visit the region annually. Urban and rural water management is a vital part of maintaining healthy coastal ecosystems that support the vibrant flora and fauna needed to maintain high levels of water quality, healthy fisheries, and tourism. Through the regions' various economic transitions, tourism has proven to be among the most consistent economic drivers and an important source of capital. In 2010, tourism, trade, and other services within the Virgin Islands accounted for roughly 57 percent of GDP and about half of total civilian employment (CIA World Factbook, 2014). Maintaining and building a healthy economy will be important to supporting revitalization efforts in the agricultural sector and in encouraging consumers to support local agricultural products. Projects like the 'Ridge to Reef' farm on St. Croix provide excellent examples of how agriculture, tourism, and coastal ecosystem management can and must be closely linked. Management practices and decisions made on farms in the coastal plain and upland areas have a direct effect on water quality at beaches and coral reefs. Agroforestry management, cover crop use, and strategic terracing are a few of the ways that producers can limit sediment runoff that reduces water clarity and harms reef health and fish populations. Organic farming minimizes pollution from fertilizer runoff that can lead to algal blooms and coral die-off. In Puerto Rico, nitrogen and phosphorous concentrations in river waters have

been observed to be as high as 10 times the estimated pre-settlement levels. The same study found fecal coliform and fecal streptococcus concentrations in many Puerto Rico rivers to be near or above regulatory limits (Larsen & Webb, 2009). River-borne nutrient and fecal discharges represent a less dramatic, but more chronic threat to coastal ecosystem health than the more episodic sediment discharges that can be largely driven by hurricanes and other intense precipitation events (Larsen & Webb, 2009; Szmant, 2002).

The negative effects of river-derived pollution on coral health, which is especially pronounced on the North, Southwest, and West coasts of Puerto Rico, highlight the need for watershed level planning to preserve the coastal systems that provide numerous ecosystem services and support tourism. Studies have shown that within the Virgin Islands, the primary sources of sedimentation are unpaved roads and land lacking vegetative cover (Macdonald et al., 1997), which are a potential target for management strategies to significantly reduce erosion rates. MacDonald et al., (1997) estimated that erosion from unpaved roads has caused a four-fold increase in sedimentation rates on St. John. Such sedimentation has been shown locally (Nemeth & Nowlis, 2001), and more generally (Fabricius, 2005), to be correlated with increases in coral bleaching rates, decreases in coral recruitment, and increases in coral disease and mortality. Poor sedimentation controls are one factor that leave coral systems increasingly vulnerable to other stressors such as increased ocean temperatures linked to climate change (Fabricius, 2005). Reduced coral coverage exposes coastal systems to increased pressure from wave action and storm surges, which can subsequently lead to greater rates of coastal erosion. Implementing and monitoring effective sediment control measures on construction and agricultural sites may represent another relatively low cost, 'no regret' strategy for limiting coastal vulnerability to climate change.

Agro-tourism could potentially supplement costs and provide incentives for implementing sustainable water-use practices. The tourism industry within the U.S. Caribbean represents a largely untapped market for agricultural stakeholders. Developing agro-tourism and motivating local businesses to showcase locally grown food and other products could help reduce a tourist trend known as leakage, which refers to tourism revenues that do not stay within the economy of the location where they are collected. Examples of this include profits generated by multi-national hotel and restaurant chains, as well as airline and cruise ship tickets. Generally, these sources provide only some low to middle income local jobs, while the bulk of the financial benefits are experienced elsewhere. This phenomena is thought to be particularly exaggerated in the U.S. Caribbean where the vast majority of food, drink, and other goods are produced externally and must be imported at high costs (Beekhuis, 1981). Marketing campaigns, local labeling, and tax incentives all represent potential strategies for creating more direct links between working lands and tourist revenue streams. Partnerships between farming cooperatives and cruise line companies should be explored for potential collaboration, since cruise ships annually bring around two million visitors to the Virgin Islands alone and represent an amazing 'captive' market for local products and agro-tours.

5. Potential Agribusiness and Niche-markets in the U.S. Caribbean

Agriculture and food enterprises in Puerto Rico are becoming increasingly oriented towards niche markets for high-value, high quality, or specialty crops and value-added products. These agribusinesses focus on market premiums and compete on the basis of higher quality, rather than lower prices. Lower prices are often an advantage foreign producers have within the island markets (Setrini, 2012). Since quality drives production for these enterprises, they can focus on narrower market niches or specific end-users. Therefore, high margins, instead of higher volumes, may be the keys to increased profitability for these producers. This 'niche focus' also enables cross-sector integration between farming and value added activities like food processing and services (Setrini, 2012). In the case of Puerto Rico, hydroponics and organic agribusinesses are some of the few areas registering growth within the islands (National Agricultural Statistics Service, 2014a). The number of hydroponic farms increased by 36 percent between 2007 and 2012 (from 156 to 213 farms) and its production value increased by over \$7 million (National Agricultural Statistics Service, 2014a). One example of a successful hydroponic business in Puerto Rico

is Huerto Isleño, which produces romaine lettuce. In 2014, the enterprise was awarded the "Hit 3001" by the Economic Development and Commerce Department during its annual competition for the best local startup company. Huerto Isleño's business plan is based on increasing the island's share of the five million heads of romaine lettuce sold in Puerto Rico each year, which currently is only 5 percent of the local market (Neggers, 2014).

5.1 Hydroponics and Organic Agriculture: A case for climate resilient farming businesses

The total dollar value of sales generated by farms selling organically-produced commodities increased from \$40,000 in 2007 to \$421,000 in 2012 (National Agricultural Statistics Service, 2014a). This increase illustrates the growing interest and the vast potential of organic agribusinesses in Puerto Rico. Furthermore, organic agriculture is increasingly being used as an adaptation strategy to address climate change and variability and to improve the livelihood of rural communities around the world (Food and Agriculture Organization of the United Nations, 2008, 2014). In part due to the application of sustainable practices, organic farming systems are often diverse, use fewer external inputs, and consume less energy than industrial agriculture. Diversified crops can improve resilience in the form of disease and pest resistance and diversified income sources. Organic farming can increase soil organic matter content and prevent nutrient exploitation, thus capturing and storing more water than soils under industrial cultivation. As a result, organic systems are less vulnerable to the effects of extreme weather conditions such as drought and flooding (Muller, 2009). Organic and agro-ecological methods for agricultural production, particularly small-scale production, also emit fewer GHGs and have the potential to sequester more carbon than industrial agriculture (Lin, 2011). However, innovative agribusinesses that want to expand local sourcing often struggle to meet retailers' quality and packaging standards and/or lack the capacity to supply consistent volumes of produce (Setrini, 2012). Niche market agriculture also requires skills in marketing that farmers may often lack, but agro-entrepreneurs in Puerto Rico tend to have higher levels of education, professional experience, and international connectivity, compared with farmers in the rest of Latin America (Setrini, 2012).

5.2 Commercial Aquaponics and Aquaculture

Aquaponics is the combined production culture of fish and hydroponic plants in recirculating systems where aquaculture effluent provides most of the nutrients required by plants (Rakocy et al., 2004). For over 30 years, the Aquaculture Program of the University of the Virgin Islands (UVI) has provided in-depth knowledge of the principles and practical application of the UVI aquaponic and biofloc tank culture systems. According to UVI, the Aquaculture Program has:

- UVI developed a commercial-scale aquaponic system (Figure 18) producing 5 million tons of tilapia annually that is harvested at 6-week intervals, as well as a variety of vegetables (lettuce harvested weekly; other crops harvested as needed);
- Nile tilapia, *Oreochromis niloticus*, is the breed of choice because it is a tropical fin-fish which tolerates the water quality and population densities characteristic of fish

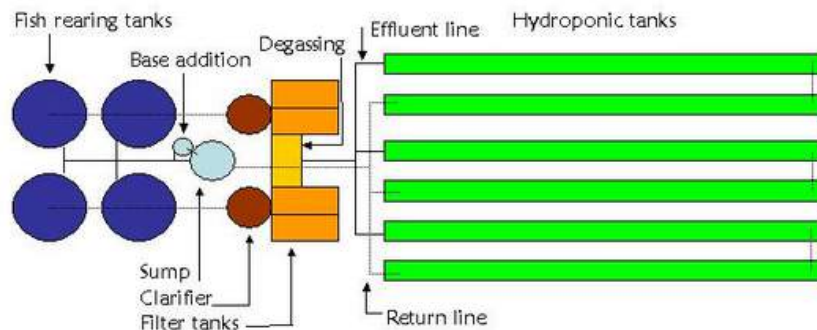

Figure 18: Deep water channel (DWC) aquaponic system – The UVI Aquaponic System

production systems. It is an herbivore and readily accepts manufactured diets made from grains and some fish meal, along with vitamin and mineral supplements to meet tilapia's nutritional demands;

- Developed a Biofloc System that produces 6,000 lbs. of tilapia per six-month crop using biologically active and suspended solids as the primary waste treatment process.

Because of its water-use efficiency, aquaponics have proven to be ideal for tropical, semi-arid environments, such as St. Croix. In addition, the island offers suitable locations and on-island expertise necessary for the development of a viable aquaculture industry. A recent assessment by the Worcester Polytechnic Institute found aquaponics to be a potentially viable farming method for Puerto Rico because the systems do not require arable land, utilize water efficiently, and avoid water pollution issues associated with traditional agriculture, (Manning et al., 2013).

6. Research and Sustainable Practices for Climate Change Adaptation and Mitigation

This section highlights two of the current research projects seeking to build resiliency into tropical agriculture within the U.S. Caribbean and abroad. Many other exciting and innovative projects are currently underway and have been discussed throughout this assessment. A primary goal of the CCSH is to help coordinate these efforts within the USDA and serve as a liaison between federal agencies, universities, and private research groups. The CCSH also hopes to assist in making the results of these research efforts readily available to farmers and working land operators within Puerto Rico and the U.S. Virgin Islands.

6.1 Use of tropical forages for climate-smart livestock production

Mixed systems integrating livestock and crops that are adapted to soil and climatic constraints is a promising strategy for sustainable agriculture in the U.S. Caribbean. Sustainable intensification of forage-based systems can help increase farm incomes, raise soil carbon accumulation, and reduce GHG emissions. Feeding high quality forage grasses reduces methane emissions from animals per unit of livestock product (Hristov et al., 2013). In Central America, the International Center for Tropical Agriculture (CIAT) has used participatory germplasm selection to address chronic dry season feed shortages and declining soil fertility in smallholder mixed crop-livestock systems. Results from this effort indicate the following (van der Hoek et al., 2012):

- Herbaceous and shrub legumes are promising options for improving animal feeding and to enhance soil quality. Benefits of using drought-adapted grasses (mainly *Brachiaria*) include increased availability of good quality feed and enhanced milk production, particularly during dry seasons;
- Mixed cropping of herbaceous legumes (e.g., *Canavalia brasiliensis*) addresses the critical issue of dry season feeding while improving soil quality. Symbiotic N fixation by the legume improves soil fertility (replacing up to 60 percent of required fertilizer) and increases subsequent maize yields. In addition, milk production increases by 20 to 30 percent when cows graze the legume-enriched maize residues;
- New options developed for small scale swine farmers include replacing up to 30 percent of cereals in feed with fresh material or forage legume silage, which can increase productivity and product quality and reduce feed costs.

6.2 Bean Breeding Program at the University of Puerto Rico in Mayagüez: New bean germplasm for drought tolerance and disease resistance

High average maximum daytime temperature above 30°C and minimum nighttime temperature above 20°C can considerably affect common bean yields in the lowland tropics less than 650 meters above sea

level (Porch et al., 2010). Scientists at the USDA Tropical Agriculture Research Station at Mayagüez, Puerto Rico are currently developing dry bean germplasm lines with increased tolerance to drought, high temperatures, and increased resistance to diseases such as common bacterial blight, root rot, and bean common mosaic virus. Their goal is to develop dry edible beans that use less water to grow. Results so far have included the release of two robust black-bean germplasm lines with improved adaptations to heat, drought, common bacterial blight, and bruchid pests (Porch et al., 2010).

6.3 Warming Experiment at the Luquillo Experimental Station in El Yunque National Forest

USFS researchers at the International Institute of Tropical Forestry (IITF) and the Luquillo Experimental Station in El Yunque, National Forest have been studying the potential effects of climate change on the region's ecologically sensitive areas since the early 2000s. Their work has included a 12-year study of how precipitation and temperature patterns are shifting across elevation gradients in the Northeast portion of the island (Beusekom et al., 2015). Luquillo Experimental station researchers are in the process of warming several research plots by 4° C (39.2° F) as part of a long-term study of how increased temperatures might affect tropical plant communities. Such studies will provide important 'ground-truthing' as more detailed climate models emerge for the islands. Results will also provide the working lands community with a window into how certain climate shifts may affect rainfall, soils, pest life cycles, and the physiological interactions among plant and animal communities.

7. USDA Programs

The 2014 USDA Climate Change Adaptation Plan⁶ presents strategies and actions to address the effects of climate change on key mission areas, including agricultural production, food security, rural development, forestry, and natural resources conservation. USDA programs administered through ARS, NRCS, USFS, Farm Service Agency (FSA), Rural Development (RD), Risk Management Agency (RMA), Animal and Plant Health Inspection Service (APHIS), and Foreign Agricultural Service (FAS) have been and will continue to play a vital role in sustaining working lands in a variable climate and are key partner agencies with the USDA Climate Hubs. In the Caribbean, Sub Hub partner agencies are also addressing issues associated with climate vulnerabilities and have programs and activities in place to help stakeholders respond to climate-induced stresses.

7.1 Natural Resources Conservation Service

NRCS has a National Technical Leader for Climate Change and technical specialists in National Technical Centers and the National Office that add capacity for technology transfer and support to NRCS State Conservationists and staff and to the more than 2,500 field offices.

NRCS is the principal federal agency that provides conservation technical and financial assistance on private agricultural and forestlands. As such, NRCS has a primary role in the delivery end of the Hub network. NRCS, along with other the USDA Service Center agencies and the Cooperative Extension System, will connect farmers, ranchers, Conservation Districts, and other public sectors to advances in climate change research and applications.

NRCS is already addressing potential effects of climate change through ongoing conservation programs and technical assistance activities that take steps to conserve and improve natural resources and assist

⁶ The 2014 USDA Climate Change Adaptation Plan includes input from eleven USDA agencies and offices. It provides a detailed vulnerability assessment, reviews the elements of USDA's mission that are at risk from climate change, and provides specific actions and steps being taken to build resilience to climate change. Find more here: http://www.usda.gov/oce/climate_change/adaptation/adaptation_plan.htm

farmers and ranchers as stewards of the land. These measures reflect the cornerstone of the goals that NRCS has had for over 75 years. Much of this assistance mitigates climate change via reduced GHG emissions or increased carbon sequestration and builds greater resiliency to climate and weather variability. A current example that reflects direct NRCS contact with producers is the Soil Health Initiative. One important aspect of this work is education and training sessions conducted for U.S. producers across the country on advantages and methods for improving the condition and resiliency of working lands soils. NRCS will continue to enhance delivery of conservation programs and assistance to working lands using advances in information and tools made more readily available through the Hub network.

In addition to technology transfer, NRCS will actively participate in determining important research directions and activities in areas supported by each Regional Climate Hub by evaluating production systems under credible climate change scenarios. NRCS will identify land management systems, conservation priorities, and conservation practices needed to protect natural resources and agricultural productivity in the face of climate change. With this practical understanding gained by this evaluation and with producer feedback, NRCS can provide input within the Hub network to agencies, universities, and organizations conducting foundational and applied research, including some applied research facilitated by NRCS.

The Role of NRCS in the Caribbean

The NRCS Conservation Practices are compromised every year because of a number of climate-related factors, including sun, weather, rain, hurricanes, and African dust, that shorten their lifespan. In addition, Operation and Maintenance are increasingly expensive every year for the same reasons. Because NRCS is a planning agency, its staff anticipates how economic and resource changes will affect conservation delivery. All NRCS programs are subject to vulnerability, and the risks in the Caribbean Area are higher than those of the continental United States. In recent years producers have been dealing with unseasonable precipitation, followed by extreme droughts, record numbers of wild fires, financial issues within the farming community, tropical pests, social issues (including Chikungunya and other diseases), and the unpredictable effects of hurricanes and African dust seasons in the region's urban communities.

7.2 United States Forest Service

The USFS is involved in research, translation, and delivery of information and technical tools for the public and private forestry sector. Forest and rangelands are key sinks of carbon, and carbon sequestration is increasingly an important management objective. Research in this area provides baseline carbon data at various scales to managers and provides methods to assess carbon in the forests and forest products and ways to integrate carbon issues in management strategies. The Research and Development (R&D) branch is USDA's principal in-house forestry and natural resource research arm. R&D has nearly 500 scientists and over 175 scientists are examining the direct and indirect effects of climate change on the Nation's forests, rangelands and urban ecosystems. The State and Private Forestry (S&PF) branch is the Federal leader in providing technical and financial assistance to landowners and resource managers to help sustain the Nation's forests and protect communities and the environment from wildland fires.

National Forest System

The USFS National Forest System manages 193 million acres and is often the "front line" when communicating with the public on natural resource management. The National Forest System (NFS) has 154 national forests and 20 grasslands organized into 9 Regions. The 439 wilderness areas total over 36 million acres of land and range in size from 372 acres in the Allegheny Islands Wilderness in Pennsylvania to 2,356,934 acres in the Frank Church-River of No Return Wilderness, which spans five national forests in Idaho. There are also 20 national recreation areas, 6 national scenic areas, 6 national monument areas, 2 national volcanic monument areas, and 2 national historic areas. The USFS NFS

works in partnership with public agencies, private organizations, tribes, watershed groups, volunteer organizations, nonprofit organizations, schools, and individuals to manage national forest resources. These include water, fish, trees, soil, recreation facilities, trails, roads, terrestrial habitats, invasive weeds, and many more.

Research and Development

Research and Development translates climate projections into scenarios describing their potential effects on forest, rangeland and urban ecosystems. These effects include changes in species composition, appearance, and function. This “translation” requires including climate change as one of many stressors that affect forest, rangeland and urban ecosystems; other factors include invasive plants, insect outbreaks, pathogens, fire and fragmentation. The resulting information is used to perform vulnerability assessments and devise management strategies that will keep these ecosystems healthy, resilient, and productive. Forest Service Research Stations directly and indirectly assist land managers in vulnerability assessments by providing models and tools, many of which are available at www.fs.fed.us/ccrc. Such efforts are underway throughout the country. Just as important as vulnerability assessments, Forest Service R&D provides the information needed to develop appropriate adaptation plans to keep ecosystems healthy, resilient, diverse, and productive. Since there is a diversity of ecosystems in the United States, the research is often, but not always, regional in scope and outlook.

Regional Stations

The five USFS research stations, the International Institute of Tropical Forestry, and the two threat assessment centers serve as regional hubs that provide key information to decision makers. In addition, there is also national expertise throughout the stations that enables the USFS to develop national assessments of the effects of climate change. One example of this is the Resources Planning Act (RPA) Assessment, which reports on the status and trends of the Nation’s renewable resources on all forest and rangelands (<http://www.fs.fed.us/research/rpa/>). The stations employ multiple approaches to climate change technology transfer, ranging from dedicated teams/staff to depending on individual scientists to move results to the field. Each station has a cadre of scientists and professional support staff who advance USFS knowledge about the effects from a changing climate. The USFS has a web portal that provides climate change information and tools in a user-friendly format for government land managers at the Climate Change Resource Center (<http://www.fs.fed.us/ccrc/>).

Forest Service Cooperative Forestry Program

The USFS Cooperative Forestry program works with States, private landowners, and other partners to promote healthy forests and livable communities throughout the United States. In partnership with State forestry agencies, Cooperative Forestry currently manages a number of programs, including the Forest Stewardship Program (FSP). This program helps private forest landowners develop plans for the sustainable management of their forests and its mission is to protect and improve the health of America’s rural, wildland, and urban forests. Forest Health Protection provides technical assistance on forest health-related matters, particularly issues related to disturbance agents such as native and non-native insects, pathogens, and invasive plants. In addition, Forest Health Protection provides forest insect, disease and invasive plant survey and monitoring information, as well as technical and financial assistance to prevent, suppress, and control outbreaks threatening forest resources. Over 250 specialists in forest entomology, forest pathology, invasive plants, pesticide use, survey, and monitoring, suppression and control, technology development, and other forest health-related services provide expertise to forest land managers throughout the Nation. The Urban and Community Forestry Program encourages states, federally-recognized tribes, and other partners to focus financial, educational, and technical assistance on helping local areas improve the resilience of their urban and community forests in response to climate-related stressors.

National Agroforestry Center

The USDA National Agroforestry Center (NAC) is a partnership between the USFS and the NRCS to accelerate the application of agroforestry through a national network of partners. NAC conducts [research](#), develops technologies and [tools](#), coordinates demonstrations and [training](#), and provides useful information to natural resource professionals.⁷

The Role of the Forest Service in the Caribbean

USFS activities in the Caribbean include the management of El Yunque National Forest (Luquillo Experimental Forest) and the administration of the International Institute of Tropical Forestry (IITF), which includes Forest Service Research and Development, State and Private Forestry, International Cooperation, the USDA Caribbean Climate Sub Hub, and the Caribbean Landscape Conservation Cooperative. Additionally, USFS International Programs administered from Washington and other Forest Service Research Stations may have activities of individual researchers or programs collaborating in the Caribbean. The scope of USFS work includes management of one National Forest and four Experimental Forests, research on American tropical forests with relevance globally, outreach and technical support through International Cooperation, International Programs, and State and Private Forestry. The scope of activities includes a wide range of cooperators, collaborators, and partners in the federal, state, nongovernmental, and private sectors which help the USFS accomplish its mission in the Caribbean. All of the USFS resources under direct management, or influenced by our research and other programs have some connection and vulnerabilities related to climate change. Of most concern to society are the ecosystem services provided by forests and rangelands. These include water, wildlife and habitat, recreation, air quality, soil conservation, and the research capacity of the USFS made possible by management of the experimental forests. USFS researches and manages some of the most biologically diverse, unique, wettest, and warmest lands in the nation. These lands, and the species and services they support are quite vulnerable to warming and drying climate, particularly the cloud forests in the Luquillo Mountains. Also vulnerable are coastal habitats managed by State and private landowner partners; as sea level rise, increased likelihood of drought and extreme storm events will affect hydrological cycles, flooding, and wildfire regimes. Additionally, most freshwater aquatic species in the Caribbean (e.g., fish, shrimp, and mollusks) have a component of their lifecycle associated with marine environments. These species and the services they provide are vulnerable to rising sea surface temperatures, ocean acidification, sea level changes, increasing storm events and sedimentation. They are also vulnerable to competition for freshwater resources from wildlife, domestic and industrial use, and agriculture.

Research on climate and climate change has been a focus of the IITF for decades. Climate change is being integrated with the forest planning of the El Yunque National Forest. USFS develops and delivers the best available science through programs in Research and Development, State and Private Forestry, International Cooperation, the USDA Caribbean Climate Sub Hub, and the Caribbean Landscape Conservation Cooperative.

7.3 Farm Service Agency

With more than 2,100 state and county offices throughout the United States, and nine offices in Puerto Rico, FSA is the “face” of USDA to producers who participate in the conservation and energy, commodity crop, disaster assistance, and farm loan programs it manages. Virtually all of FSA’s programs affect producers’ ability to adapt to and even mitigate the effects of climate change:

- The Conservation Reserve Program (CRP), one of the largest voluntary conservation programs in the world, provides incentives to producers to take marginal or vulnerable cropland out of

⁷ See <http://nac.unl.edu/>

production for 10-15 years in order to improve soil health, effectively eliminate erosion, enhance water quality, and create wildlife habitat. Under the Agricultural Act of 2014 (the 2014 Farm Bill), grassland can also be enrolled in and maintained under CRP.

- The Biomass Crop Assistance Program provides incentives to producers to establish, cultivate, and harvest eligible biomass for heat, power, bio-based products, research, and advanced biofuels.
- The new Price Loss Coverage and Agricultural Risk Coverage programs, along with the Marketing Assistance Loan and other existing programs, help mitigate price and yield risks that producers face. These programs help maintain farm incomes and keep farmers on the land.
- The Noninsured Crop Disaster Assistance Program, Livestock Forage Disaster Program, Livestock Indemnity Program, and other programs provide emergency assistance to producers when drought and other disasters affect agricultural production.
- The Direct and Guaranteed Loan Programs provide many farmers and ranchers the opportunity to obtain needed credit to begin and continue operations, particularly when it is difficult to obtain commercial credit. Under 2014 Farm Bill, the ability to help beginning and socially disadvantaged producers has been enhanced.

The Role of FSA in the Caribbean

In Puerto Rico, climate change that affects production and reduces crop yields and livestock inventory will affect the program benefits to be received by FSA participants. Adverse effects from climate change can reduce farmer income, and may increase the odds that producers will need to stop farming and find other ways to earn money.

Additional vulnerabilities include:

- Clams and oysters thrive only in waters of fairly exact salinity levels. As sea levels rise, sea water with higher salinity levels will intrude into less-saline waters where commercial clam and oyster production is currently conducted. This could result in the eradication of clams and oysters from many, if not all, of current production regions.
- Sea level rise will increase salt-water intrusion into freshwater aquifers and surface waters that are sources of water used for irrigation. Resulting saline irrigation water could kill plants, pollute agricultural soils, and corrode equipment and irrigation devices.
- In many coastal areas, tens of thousands of acres of commodity crops and specialty fruits are grown in hydric soils that are very near sea level. As sea levels rise, huge areas will become non-arable because they will be flooded or will become too wet.

Within Puerto Rico, FSA administers the CRP, as well as the Conservation Contract under the Debt for Nature Program for actual borrowers and the Emergency Conservation Program for all Puerto Rico farmers. The FSA provides general technical assistance to farm programs and loan program participants. This includes assistance in completing farm business plans, providing financial and production training, and conducting quality farm assessments. The FSA works with local and Federal partners in identifying the needs of customers and maximizing financial and technical assistance. In addition, the FSA is involved in disseminating information about conservation programs administered by FSA and other USDA agencies to farmers, ranchers, and forest landowners.

7.4 Rural Development

RD is committed to the future of rural communities by increasing economic opportunities for rural residents. RD provides technical assistance and financial backing for rural businesses and cooperatives to create quality jobs in rural areas. By improving the fiscal health of the rural economy, farmers, ranchers, and forestland owners are better able to invest in practices that will keep their lands healthy and resilient

into the future. Program examples include Emergency Community Water Assistance Grants (ECWAG) and programs that promote bio-based fuels and products.

The Role of Rural Development in the Region

The majority of farmers in the U.S. Caribbean are small-scale producers, and local ecosystems are already experiencing issues stemming from human activities. Because of their limited landmass, each of the 3 Virgin Islands is extremely vulnerable to climate change effects, and rising sea levels will reduce current landmass via flooding. Similarly, issues with coastal erosion will affect marine species that are native to the Virgin Islands, including any endangered species. Changes in rainfall patterns could lead to more frequent droughts, as well as sustained periods of rain and flooding. It is possible that climate change will also result in an increase in tropical diseases.

Current regional agricultural production is not sufficient to meet demand, and this situation would be exacerbated in the event of a disaster. This could lead to population declines and migration to the U.S. mainland, and insurance costs might also rise. Adaptations are general in nature, and what might work on one island may not be suitable for another island. Meetings with local U.S. Caribbean agricultural and extension groups can be held to explore the potential similarities and differences that will be needed to support each island's efforts to adapt to climate change.

7.5 Risk Management Agency

RMA provides a variety of crop and livestock related insurance products to help farmers and ranchers manage the risks related to agricultural production. Coverage is provided against agricultural production losses due to unavoidable natural perils such as drought, excessive moisture, hail, wind, hurricane, tornado, lightning, and insects, etc. In 2014 the Federal crop insurance program provided U.S. agricultural producers with over \$109.8 billion in agricultural commodity protection. These policies provide financial stability for agricultural producers and rural communities, and are frequently required by lenders.

Climate change is an ongoing process, so the risk environment for agricultural production will also be undergoing constant change, e.g., some perils may occur with greater (or lesser) frequency and/or severity. Climate change will also promote adaptive responses by producers, such as adopting new production practices, planting new varieties, or shifting the locations of farming operations.

RMA continually strives to improve the effectiveness of programs by refining insurance offers in light of changes in production practices. This includes adjusting program parameters (e.g., premium rates, planting dates, etc.) within each county to recognize structural changes to crop production risks in those areas. Because of this activity, RMA monitors climate change research and, to the extent that climate changes emerge over time, updates program parameters to reflect adjustments in adaptation or other changes. RMA also updates loss adjustment standards, underwriting standards, and other insurance program materials to ensure that the products are appropriate for prevailing production technologies.

In addition to providing crop insurance coverage to growers, RMA enters into partnerships with public and private entities for the development of non-insurance risk management tools and to provide risk management education and outreach. These efforts are undertaken to assist producers in mitigating and adapting to increased risks from climate change, drought, and other weather-related conditions. The partnerships are wide-ranging, multi-year, research projects that extend beyond traditional crops and offer new and innovative approaches to risk management.

In 2010, RMA's crop insurance National liability (book of business) was \$78 billion. In 2014, RMA's National liability was \$109.8 billion.

Caribbean Region

In 2010, six types of crops (Coffee crop/plantation, Farinaceous, Fruit Orchards, Vegetables, Citron, and Citrus) were insured in Puerto Rico, with \$67.2 million in liability. In 2014, crop insurance business declined to \$53 million for these six crop categories.

From 2010 to 2014, crop insurance participation and liabilities for Puerto Rico have declined. But crop insurance remains as an important risk management tool for local producers, especially if losses occur as a result of natural disasters such as hurricanes. The crop with the highest liability exposure for the Federal crop insurance program in the Caribbean Sub Hub region is coffee /plantation.

- Coffee crop/plantation liability decreased from \$31.5 million in 2010 to \$19.6 million in 2014;
- Farinaceous (bananas, plantain crop, yams) liability decreased from \$20.4 million to \$19.3 million;
- Fruit Orchards (passion fruit, avocado, papaya) liability increased from \$6.9 million to \$7.3 million;
- Three other crops insured (citron, citrus, vegetables) had liabilities under \$7 million.

RMA's Valdosta Regional Office will continue to monitor crop disasters such as hurricanes, excess precipitation, and drought. RMA will respond to Approved Insurance Providers and producer inquiries during these events. In addition, RMA's Valdosta Regional Office will continue to provide RMA headquarters in Washington, D.C., with estimates of liabilities, losses and the potential effect that natural disasters have on the Federal crop insurance program.

7.6 Animal and Plant Health Inspection Service

APHIS is responsible for protecting and promoting U.S. agricultural health, regulating genetically engineered organisms, administering the Animal Welfare Act, and carrying out wildlife damage management activities. APHIS is constantly working to defend U.S. plant and animal resources from agricultural pests and diseases. Once a pest or disease is detected, APHIS works in partnership with affected regions to manage and eradicate the outbreak. APHIS has four strategic goals: 1) to support rural communities; 2) to protect forests, rangelands, and private lands; 3) to expand opportunities to develop and trade safe agricultural products, including biotechnology-derived agricultural products; and 4) to minimize and prevent damage to the U.S. food supply caused by plant and animal pests and diseases. In the face of an increasingly variable climate and more erratic weather conditions, APHIS will continue to play a central role in responding to risk and managing vulnerabilities.

Many countries in the Caribbean share common regional characteristics that increase their vulnerability to climate change effects. These include; small land masses, very limited natural resources, high susceptibilities to natural catastrophic events, high population densities concentrated within coastal zones, and high dependence on agriculture and tourism (Baban, 2003).

Agriculture production remains the backbone for the economic activities in the Caribbean Basin. A large proportion of the population depends on agriculture. The agricultural sector accounted for 5 percent of the region's gross domestic product (GDP) in 2012, but contributed to more than 10 percent of total GDP in several Caribbean nations (Inter-American Development Bank, 2014).

Climate change reports for the Caribbean Basin have stated that average air temperatures within the region have increased by approximately 1 percent over the last 30 years and sea levels have risen approximately 2-3 mm per year since 1980 (Caribbean Catastrophe Risk Insurance Facility, 2010; Harmsen et al., 2009).

Climatic changes that are causing the greatest adverse effects in the Caribbean Basin include:

- ***West African Dust Plume*** – Severe droughts in the Soudano-Sahel region of Africa (attributable to human activities) are causing great quantities of mineral dust⁸ that are carried by winds from Africa to the Caribbean Basin during most of the year, particularly in the summer during June and July (Prospero & Lamb, 2003). The plume has created dense dust hazes throughout the area causing a “greenhouse effect” that prevent gas emissions from dissipating into the atmosphere, elevate air temperatures, suppress rainfall and create conditions favorable for drought.
- ***More extreme hurricane seasons*** – Hurricane formation, size, intensity and movement are heavily influenced by the world’s heat balance and momentum (Lugo, 2000). Hurricanes have significantly disturbed landscapes by direct sudden effects on vegetation cover and ecosystems processes. High rainfalls caused by hurricanes result in landslides, mudslides, and debris slides that consequently interact with land topography and change geologic substrates on the affected sites. Likewise, the high winds caused by hurricanes increase massive tree mortalities (an average 41.5 percent, compared to a typical tree mortality rate of 1.6 percent), generate large storm waves, results in salt water flooding into coastal areas that changes soil mineral compositions; and delays the regeneration of vegetation cover in affected sites (Lugo, 2000). These changes may also create favorable ecological niches for emerging animal infectious diseases (de la Rocque et al., 2008).
- ***Drier “dry seasons”*** – The dry season in the Caribbean (November – July) has become drier and warmer during the last years whereas the wet season (August-October) is becoming wetter. This means that for approximately 75 percent of the year the Caribbean is going thru extended periods of droughts because of marked decreases in rainfall (Inter-American Development Bank, 2014) whereas an increase in catastrophic flooding events are expected in the wet season. These changes in seasonal conditions may affect insect vector behavior in terms of disease spread pattern, diffusion range, amplification and persistence in novel habitats (de la Rocque et al., 2008).
- ***Gradual sea level rise and coastal erosion*** – These processes pose a threat of severe ecological disruption that will likely affect Caribbean agricultural structures and economies within the coastal zones approximately 2 km from the coast (Lewsey et al., 2004). A high percentage of agricultural land in this region is located on flat coastal plains that are subject to rises in sea levels and inland saltwater flooding. The flooding can adversely affect agricultural land by increasing saline levels in soils, lagoons, estuaries, wells, and aquifers. Potable water supply for crops and livestock might become very limited. Studies in Belize and Jamaica have shown that the volume of sugar cane production is predicted to fall up to 45 percent in 2030 due to potential climate zone shifts.

These natural and man-made phenomena are affecting the Caribbean agriculture in several ways, including the following:

- Reductions in crop yield have been observed during the dry period (Harmsen et al., 2009). Key crops might not be able to maintain photosynthesis activities as temperatures continue to rise (temperatures greater than 84° F and 86° F are harmful to corn and soybeans). Endemic crop varieties are less capable of surviving changes in climate. Production costs will increase because of the need to locate suitable sites to maintain reasonable crop production.
- Redistribution and zone shifts of tropical plants and animals, which will affect the distribution and levels of agricultural pests and animal and plant diseases. Warmer temperatures alter pest

⁸ Mineral dust is mainly constituted of the oxides (SiO₂, Al₂O₃, FeO, Fe₂O₃, CaO, and others) and carbonates (CaCO₃, MgCO₃) that constitute the Earth's crust.

Caribbean Region

population growth rates, extend the season of pest development, and increase risk of invasion by migrant pests (Porter et al., 1991). Increases in agricultural pests and plant diseases due to climate change have been reported in Colombia for bananas, plantains, coffee, potato, cacao, maize and cassava (Lau et al., 2013). The significant increase in agricultural pests has forced producers to extensively and indiscriminately use large quantities of pesticides, which has resulted in environmental damage to coastal marine life. Pesticide runoff has also significantly harmed marine habitats and contaminated seafood. Fisheries, which provide significant revenue earnings, are among the most important agricultural commodities in the Caribbean that have declined due to corals reef siltation (Baban, 2003).

- Many infectious animal diseases, particularly those that are vector-borne, are influenced by environmental changes (de la Rocque et al., 2008). The distribution of diseases like dengue, trypanosomosis, leishmaniosis, Lyme disease, tick borne encephalitis, and bluetongue have changed in recent decades. Increases in temperature directly affect arthropod vectors life cycles by augmenting insect metabolic rates, egg production rates, and blood meal feeding-frequencies (de la Rocque et al., 2008).

The following measures have been considered for managing risks and vulnerabilities related to climatic changes in the Caribbean region:

- Increased funding directed to agricultural research in the Caribbean and the effect of global environmental changes on agriculture (Inter-American Development Bank, 2014);
- Improved production practices, including irrigation, soil conservation, water management, pesticides applications, and pest and disease management;
- Improvements in climatic and oceanographic surveillance and deployment of early warning systems;
- Development and use of climate resilient crop varieties and species, such as the development of healthier maize cultivars to grow hybrids more resistant to climatic changes (Carena, 2013);
- Revisions of current agricultural policies and programs (Inter-American Development Bank, 2014);
- Public awareness and education programs (Lewsey et al., 2004);
- Using dikes, improved construction techniques, building retrofits, enhanced building codes, and protective ecological habitats such as mangrove in the fringe of the coastal zones (Caribbean Catastrophe Risk Insurance Facility, 2010; Lewsey et al., 2004);
- Using risk transfer solutions such as transferring part of the risk to a third party (i.e. insurance companies) (Caribbean Catastrophe Risk Insurance Facility, 2010);
- Some Caribbean countries are working on national adaptation strategies called National Adaptation Programmes of Action (NAPAs) to mitigate adverse climate change effects (Caribbean Catastrophe Risk Insurance Facility, 2010);
- Improve potable water supply use, including the efficiency of irrigation systems (Lewsey et al., 2004);
- Improve soil management by using efficient drainage techniques and watershed management (Lewsey et al., 2004).

In 2014, APHIS developed an *Adaptation Plan*⁹ to cope with current and future climatic change challenges. Climate change has become a very important variable in the development of APHIS policies, predictive and epidemiological models, risk assessments, and operational strategies, including domestic and offshore surveillance. A top APHIS priority is to develop prevention and mitigation strategies that can be used in manage the effects of climate change on U.S. plant and animal resources. APHIS, in

⁹ See http://www.usda.gov/oce/climate_change/adaptation/Animal_and_Plant_Health_Inspection_Service.pdf

Caribbean Region

coordination with other Federal agencies and cooperators, is constantly monitoring weather trends, agricultural pest distributions, and exotic plant and animal disease outbreaks to develop activities for protecting U.S. agriculture, natural resources, commerce, and trade.

- The Veterinary Services (VS) Center for Epidemiology and Animal Health (CEAH) and Wildlife Services National Wildlife Research Center are the Agency leaders for developing processes that will incorporate climate change modeling into risk assessments. They are also identifying specific agricultural pests, diseases, or vectors that have changing U.S. distributions resulting from climate change. Likewise, VS field officers in the Caribbean have been involved in projects that study the effect of integrated control strategies in vector-borne diseases, including diseases transmitted by insects including ticks, midges, and mosquitoes. Puerto Rico is currently the venue for a major study to develop improved strategies for controlling cattle fever ticks (*Rhipicephalus Boophilus microplus*) in livestock. Knowledge gained from these studies will help manage cattle fever tick population shifts in the northern part of Texas.
- APHIS plant health scientists are working with university researchers to elucidate the effect of climate changes on citrus canker. This has resulted in a redesign of the regulatory approach and identification of new measures for crop protection. Plant Protection and Quarantine (PPQ) Center is working with USGS to develop epidemiological forecasting tools for plant pests and diseases.
- APHIS is also working to integrate climate change modeling into its emergency preparedness and biosecurity hazard planning, which will enhance the ability of the Agency to predict, mitigate, and adapt to adverse conditions caused by extreme weather changes. Marketing and Regulatory Programs Business Services (MRPBS) Emergency Management Safety and Security Division is responsible for 1) revising the Emergency Support Function (ESF) #11 Annex to the National Response Framework (plans and concepts of operations); and 2) developing food and agriculture incident annexes for FEMA regions, including FEMA Region 2, which includes Puerto Rico and the U.S. Virgin Islands in the Caribbean region.
- Demands will increase for APHIS resources, including permits and notification applications, inspections, compliance issues, and deregulation petitions, as demands for genetically engineered crops increase.

7.7 Agricultural Research Service

ARS is the principal in-house agricultural research arm of USDA and conducts research under the thematic areas of:

- Crop Production and Protection
- Animal Production and Protection
- Natural Resources and Sustainable Agriculture Systems
- Nutrition, Food Safety and Quality.

Each of these thematic areas has climate change research components. ARS climate change mitigation research focuses on management of GHG emissions from agricultural sources and enhancement of carbon sequestration. ARS climate change adaptation research includes understanding the effects of climate change on agricultural systems, developing technologies that enable agriculture to adapt to abiotic and biotic effects of climate change, and identifying climate change effects that may be beneficial for agriculture.

The research includes laboratory, plot, field, landscape, and larger studies that incorporate foundational measurements to study and explain processes, and that result in the delivery of decision support

technologies to users and stakeholders. ARS has 90 research locations nationwide and four overseas laboratories. Interdisciplinary, cross-location ARS research networks include:

- Long Term Agroecosystem Research (LTAR) network
- Greenhouse gas Reductions through Agricultural Carbon Enhancement network (GRACEnet)
- Livestock GRACEnet
- Conservation Effects Assessment Project (CEAP)
- Renewable Energy Assessment Project (REAP)

ARS employs remote sensing research to (1) develop new systems to measure and monitor crop production and environmental systems, and (2) develop crop growth and yield models, erosion models, hydrologic models, soil process models and air emission models that can be used to plan for and deal with the challenges of a changing climate. ARS scientists are providing scientific leadership to the Agricultural Modeling Intercomparison and Improvement Project (AgMIP), which has the goal of improving projections of future crop production under different climate change scenarios provided by the climate science community. ARS led the development of technical references for the agriculture section of the United States Global Change Research Program (USGCRP) National Climate Assessment (NCA) and is building elements of the NCA process into its climate change research agenda.

ARS research is also developing data management systems to make ARS research data and models available and accessible to other researchers. A focal point for this effort is the National Agricultural Library, which is a part of the ARS system.

The Role of ARS in the Region

Excess rainfall in some areas of the Caribbean, particularly in areas with heavy clayey soils, can result in semi-anaerobic conditions which could lead to disease (root rots) and tree fruit death. The production of common bean (*Phaseolus vulgaris*) in the lowlands during the warmer summer season is vulnerable to increasing temperatures, because the high ambient temperatures during this season already result in a significant reduction in common bean yields. ARS scientists in Puerto Rico are conducting research on avocado (*Persea americana*) and mamey sapote (*Pouteria sapota*) to identify rootstocks with resistance to the fungi that cause root rot. Similarly, several common bean breeding programs at the University of Puerto Rico, Escuela Agricola Panamericana (Zamorano) in Honduras, and the ARS laboratory in Mayaguez, Puerto Rico, are breeding for drought and heat tolerance, and for associated disease resistance associated with climate change. In addition, ARS has started a breeding program for tepary bean (*Phaseolus acutifolius*), a highly abiotic tolerant orphan crop with potential for production in marginal environments.

7.8 Foreign Agricultural Service (FAS)

FAS links U.S. agriculture to the international community to enhance export opportunities and global food security. In addition to its Washington, D.C. staff, FAS has a global network of 96 offices covering 167 countries. These offices are staffed by agricultural attachés and locally hired agricultural experts who are the eyes, ears, and voice for U.S. agriculture around the world. FAS staff identify problems, provide practical solutions, and work to advance opportunities for U.S. agriculture and support U.S. foreign policy around the globe.

Programs and Services

Trade Policy: FAS expands and maintains access to foreign markets for U.S. agricultural products by removing trade barriers and enforcing U.S. rights under existing trade agreements. FAS works with foreign governments, international organizations, and the Office of the U.S. Trade Representative to establish international standards and rules to improve accountability and predictability for agricultural trade.

Market Development and Export Assistance: FAS partners with 75 cooperator groups representing a cross-section of the U.S. food and agricultural industry and manages a toolkit of market development programs to help U.S. exporters develop and maintain markets for hundreds of products. FAS also supports U.S. agricultural exporters through export credit guarantee programs and other types of assistance.

Data and Analysis: The FAS network of global contacts and long-standing relationships with international groups contribute to the Agency's unique market intelligence capacity. FAS analysts provide objective intelligence on foreign market opportunities, prepare production forecasts, assess export marketing opportunities, and track changes in policies affecting U.S. agricultural exports and imports.

Food Security: FAS leads USDA efforts to help developing countries improve their agricultural systems and build their trade capacity. FAS also partners with the U.S. Agency for International Development to administer U.S. food aid programs, which helps people in need around the world. FAS's non-emergency food aid programs help meet recipients' nutritional needs and also support agricultural development and education.

8. Conclusions

This assessment highlights some of the diverse vulnerabilities in the tropical forestry and agricultural sectors of the U.S. Caribbean. It represents an initial step toward understanding how the climate change may affect the people, agencies, products, and capacities in the region. The primary purpose is to better understand the regional vulnerabilities and potential adaptive strategies in order to target and guide resources, collaborative efforts, research, and best practices that will lead to strong, resilient, and climate smart agricultural and forestry sectors. Climate change presents the U.S. Caribbean with many of the same challenges that confront the continental United States. However, limited land availability and population pressures provide an almost 'self-contained' system in which comprehensive, cohesive, coordinated, and reflective management are an absolute necessity. The models, prototypes, and success stories built in the U.S. Caribbean will not only serve as an example to other islands in the region and world; they also have the potential to help shift the general land management paradigm towards one that works to preserve quality of life through integrated landscape level management. Embedded within this paradigm are socio-economic issues that are every bit as necessary and important to confront as those within the bio-physical realm. It will be extremely difficult for the region to achieve a higher level of food security without simultaneously confronting issues of land use planning and development, economic growth, water management, and soil conservation. Practitioners and advisors alike are fully aware of the connections between these issues, but they are often addressed within 'siloes' management regimes and institutions that can be remote, disconnected, and highly politicized. Throughout our initial outreach within the working lands community, a great deal of concern has been expressed over the loss and degradation of some of the islands' most fertile soils. Many attribute these losses to poor management practices and a lack of enforcement of existing land use regulations that frequently result in encroachment by development. Puerto Rico is the most densely populated region within the United States and also suffers from some of the highest unemployment and poverty rates. This confluence of issues can inadvertently support poorly planned and hasty development projects as decision-makers seek to obtain short-term economic gains. For those suffering from a critical lack of resources and opportunity, the issues of today can seem much more critical than those of tomorrow. However, these short-term advances can hamper the long-term viability of island economies and culture if such activities are not planned and conducted in ways that enhance human well-being and sustain cultural and natural resources.

In providing this initial vulnerability assessment, the Caribbean Climate Sub Hub hopes to begin a process of assimilating critical information and highlighting innovations that will enable the U.S. Caribbean to build a strong and resilient future in the face of climate change. These innovations may arise from local leaders and informal networks as well as from national and global sources. As in many places

Caribbean Region

within the continental United States, a younger generation within the region is awakening to the possibilities that agriculture and forestry present. Demand for fresh, high quality, local products is on the rise and may represent a turning point in regional efforts to develop sustainable forestry and agriculture sectors that are economically viable and that reflect the unique cultural and environmental heritage of the region. It is the desire of the Hub to support these efforts and to become a critical nexus in the flow of information and ideas between formal institutions and agencies and the grassroots organizations and producers working to turn the tide of agricultural decline and food insecurity. This assessment may be periodically updated to integrate new expertise on crop systems, climate and communication, and to include more crops, emerging products and practices, as well as tools and resources available to farmers, ranchers, foresters, and forestry and agricultural research and advisory communities.

References

- Abruna, F, Vicente-Chandler, J, & Silva, S. (1959). The Effect of Different Fertility Levels on Yields of Intensively Managed Coffee in Puerto Rico. *Journal of Agriculture of the University of Puerto Rico*, 43, 141-146.
- Adam, NR, Wall, GW, Kimball, BA, Idso, SB, & Webber, AN. (2004). Photosynthetic Down-Regulation over Long-Term Co2 Enrichment in Leaves of Sour Orange (*Citrus Aurantium*) Trees. *New Phytologist*, 2(163), 341-347.
- Adger, WN. (2006). Vulnerability. *Global Environmental Change*, 16(3), 268-281.
- Alberts, HW, & Molinari, OG. (1943). Pastures of Puerto Rico and Their Relation to Soil Conservation: US Department of Agriculture.
- Alperen, MJ. (2006). *Towards a Homeland Security Strategy for the United States Virgin Islands*. (Master's), Naval Post Graduate School.
- Araújo, XJ. (2011, 29 de julio). Auguran Fin De La Carne De Res Local. *El Nuevo Día*.
- Arrillaga, JG, & Gomez, LA. (1942). Effect of Solar Radiation Intensity on the Vegetative Growth and Yield of Coffee. *Journal of Agriculture of the University of Puerto Rico*, 25, 73-90.
- Baban, SMJ. (2003). Responding to the Effects of Climate Change on Agriculture, Fisheries and Tourism in the Caribbean Region Utilizing Geoinformatics. *Farm & Business: The Journal of the Caribbean Agro-Economic Society*, 6(1), 95-111.
- Barker, D. (2012). Caribbean Agriculture in a Period of Global Change: Vulnerabilities and Opportunities. *Caribbean Studies*, 40(2), 41-61.
- Beekhuis, J. (1981). Tourism in the Caribbean: Impacts on the Economic, Social and Natural Environments. *Ambio*, 10(6), 325-331.
- Bertrand, A, Pr.vost, D, Bigras, FJ, Lalande, R, Tremblay, GF, Castonguay, Y, & G.B.langer. (2008). Alfalfa Response to Elevated Co₂ Varies with the Symbiotic Rhizobial Strain. *Plant Soil*, 301, 173-187.
- Beusekom, AE, González, G, & Rivera, MM. (2015). Short-Term Precipitation and Temperature Trends Along an Elevation Gradient in Northeastern Puerto Rico. *Earth Interact*, 19, 1-33. doi: <http://dx.doi.org/10.1175/EI-D-14-0023.1>
- Birdsey, RA, & Weaver, PL. (1987). Forest Area Trends in Puerto Rico.
- Blackburn, J. (2011, September 16). Island Dairies to Close after 52 Years; 25 Jobs to Be Lost. *Virgin Islands Daily News*.
- Borkhataria, R, Collazo, JA, Groom, MJ, & Jordan-Garcia, A. (2012). Shade-Grown Coffee in Puerto Rico: Opportunities to Preserve Biodiversity While Reinvigorating a Struggling Agricultural Commodity. *Agriculture, Ecosystems & Environment*, 149, 164-170.
- Briscoe, CB, & Wadsworth, FH. (1970). Stand Structure and Yield in the Tabonuco Forest of Puerto Rico.

- Brokaw, N, Crowl, TA, Lugo, AE, McDowell, WH, Scatena, FN, & Waide, RB. (2012). *A Caribbean Forest Tapestry: The Multidimensional Nature of Disturbance and Response*. New York, New York: Oxford University Press.
- Brown, S, & Lugo, AE. (1984). Biomass of Tropical Forests: A New Estimate Based on Forest Volumes. *Science*, 233(4642), 1290-1293.
- Brown, S, & Lugo, AE. (1990). Tropical Secondary Forests. *Journal of tropical ecology*, 6(01), 1-32.
- Carena, MJ. (2013). Developing the Next Generation of Diverse and Healthier Maize Cultivars Tolerant to Climate Changes. *Euphytica*, 190, 471-479.
- Caribbean Business. (2014, July 29). Puerto Rico Moves Closer to Water Rationing. Retrieved from <http://www.caribbeanbusinesspr.com/news/pr-moves-closer-to-water-rationing-99104.html>
- Caribbean Catastrophe Risk Insurance Facility. (2010). Enhancing the Climate Risk and Adaptation Fact Base for the Caribbean. In E. o. C. A. E. Study (Ed.).
- Carro-Figueroa, V. (2002). Agricultural Decline and Food Import Dependency in Puerto Rico: A Historical Perspective on the Outcomes of Postwar Farm and Food Policies. *Caribbean Studies*, 77-107.
- Centritto, M, Lee, HSJ, & Jarvis, PG. (1999). Increased Growth in Elevated [CO₂]: An Early, Short-Term Response? *Global Change Biology*, 5(6), 623-633. doi: 10.1046/j.1365-2486.1999.00263.x
- Centro de Recursos Informativos Agrícolas de Puerto Rico. (2013). from <http://www.cridag.net>
- Chazdon, RL. (2008). Beyond Deforestation: Restoring Forests and Ecosystem Services on Degraded Lands. *Science*, 320(5882), 1458-1460.
- CIA World Factbook. (2014). Retrieved June 10, 2015, from <https://www.cia.gov/library/publications/the-world-factbook/geos/vq.html>
- Comas, M. (2009). *Vulnerabilidad De Las Cadenas De Suministros, El Cambio Climático Y El Desarrollo De Estrategias De Adaptación: El Caso De Las Cadenas De Suministros De Alimento De Puerto Rico*. (Disertación doctoral), Universidad de Puerto Rico.
- Cordero-Mercado, D. (2014, 23 de abril). Agricultura Y Ambiente: El Debate Por La Madre Tierra. *Periódico Diálogo Digital*.
- Coto, D. (2014, July 30th, 2014). Puerto Rico Warns Strict Water Rationing Near. *Associate Press*. Retrieved from <http://news.yahoo.com/puerto-rico-warns-strict-water-rationing-near-185426052.html>
- Daly, C, Helmer, EH, & Quinones, M. (2003). Mapping the Climate of Puerto Rico, Vieques and Culebra. *International Journal of Climatology*, 23(11), 1359-1381.
- Damatta, F, Ramalho, M, & Cochicho, JD. (2006). Impacts of Drought and Temperature Stress on Coffee Physiology and Production: A Review. *Brazilian Journal of Plant Physiology*, 18(1), 55-81.

Caribbean Region

- Dansereau, P. (1966). Studies on the Vegetation of Puerto Rico. *Description and integration of the plant communities*. Mayaguez, Puerto Rico, PR , US: Institute of Caribbean Science Special Publication 1.
- Davis, JR, & Santiago, CL. (2000). Soil Survey of the United States Virgin Islands: Natural Resources Conservation Service United States Department of Agriculture,
Virgin Islands Department of Planning and Natural Resources,
Virgin Islands Cooperative Extension Service,
United States Department of Interior, National Park Service.
- de la Rocque, S, Rioux, JA, & Slingenbergh, J. (2008). Climate Change: Effects on Animal Disease Systems and Implications for Surveillance and Control. *Revue scientifique et technique (International Office of Epizootics, 27(2), 339-354.*
- Dietz, JL. (1986). *Economic History of Puerto Rico: Institutional Change and Capitalist Development*: Princeton University Press.
- Dookhan, I. (1974). *A History of the Virgin Islands of the United States*. Kingston, Jamaica: Canoe Press.
- Druta, A. (2001). Effect of Long Term Exposure to High CO₂ Concentra-Tions on Photosynthetic Characteristics of Prunus Avium L. Plants. *Photosynthetica, 39(2), 289-297.*
- Duewer, LA, Nelson, KE, & Crawford, TL. (1989). Effects of Meat Imports on the Puerto Rican Livestock-Meat Industry *Animal industry* (pp. 49). Economic Research Service: Department of Agriculture.
- Ewel, JJ, & Whitmore, JL. (1973). Ecological Life Zones of Puerto Rico and US Virgin Islands *Ecological life zones of Puerto Rico and US Virgin Islands* US Department of Agriculture.
- Fabricius, KE. (2005). Effects of Terrestrial Runoff on the Ecology of Corals and Coral Reefs: Review and Synthesis. *Marine pollution bulletin*, pp. 125-146.
- Food and Agriculture Organization of the United Nations. (2008). Good Agricultural Practices for Climate Risk Management in Grenada Summary Report.
- Food and Agriculture Organization of the United Nations. (2014). The State of Food Insecurity in the World 2014. Strengthening the Enabling Environment for Food Security and Nutrition. Rome: FAO.
- Francis, JK. (1995). *Forest Plantations in Puerto Rico*. New York: Springer
- Francis, JK, & Lowe, CA (Eds.). (2000). *Silvics of Native and Exotic Trees of Puerto Rico and the Caribbean Islands (Spanish Version)*. Puerto Rico: U.S. Department of Agriculture, Forest Service International Institute of Tropical Forestry.
- Gamble, D, Parnell, D, & Curtis, S. (2009). *Caribbean Vulnerability: Development of an Appropriate Climatic Framework. Global Change and Caribbean Vulnerability: Environment, Economy and Society at Risk*. Kingston: University of the West Indies Press.

- Ganpat, WG, & Isaac, WP. (2014). *Impacts of Climate Change on Food Security in Small Island Developing States*. Trinidad and Tobago: The University of the West Indies,.
- Gay, C, Estrada, F, Conde, C, Eakin, H, & Villers, L. (2006). Potential Impacts of Climate Change on Agriculture: A Case of Study of Coffee Production in Veracruz, Mexico. *Climatic Change*, 79(3-4), 259-288.
- Gonzalez, G, Waide, RB, & Willig, MR. (2014). *54 Ecological Bulletins Ecological Gradient Analyses in a Tropical Landscape* (Vol. Number 54). Hoboken, NJ: Wiley-Blackwell.
- Gould, WA, Alarcón, C, Fevold, B, Jiménez, ME, Martinuzzi, S, Potts, GS, & Ventosa, E. (2008). The Puerto Rico Gap Analysis Project. Volume 1: Land Cover, Vertebrate Species Distributions, and Land Stewardship (I. I. o. T. Forestry, Trans.) (pp. 165). Río Piedras, PR.: US Department of Agriculture, Forest Service.
- Gould, WA, González, G, & Carrero Rivera, G. (2006). Structure and Composition of Vegetation Along an Elevational Gradient in Puerto Rico. *Journal of Vegetation Science*, 17, 653–664.
- Gould, WA, Martinuzzi, S, & I.K., P-R. (2012). Land Use, Population Dynamics, and Land-Cover Change in Eastern Puerto Rico. In S. F. Murphy & R. F. Stallard (Eds.), *Water quality and landscape processes of four watersheds in eastern Puerto Rico: U.S. Geological Survey Professional Paper 1789* (pp. 25-42).
- Grau, HR, Aide, TM, Zimmerman, JK, Thomlinson, JR, Helmer, E, & Zou, X. (2003). The Ecological Consequences of Socioeconomic and Land-Use Changes in Postagriculture Puerto Rico. *Bioscience*, 53(12), 1159-1168.
- Hall, DO, & Scurlock, JMO. (1991). Climate Change and Productivity of Natural Grasslands. *Annals of Botany*, 67(supp1), 49-55.
- Harmsen, EW, Miller, NL, Schlegel, NJ, & Gonzalez, JE. (2009). Seasonal Climate Change Impacts on Evapotranspiration, Precipitation Deficit and Crop Yield in Puerto Rico. *Agricultural Water Management*, 96, 1085-1095.
- Hayhoe, K. (2013). Quantifying Key Drivers of Climate Variability and Change for Puerto Rico and the Caribbean *Final Report 1 Oct 2011-30 Sep 2012*. (pp. 241).
- Helmer, EH, Ramos, O, López, Td, Quiñones, M, & Díaz, W. (2002). Mapping the Forest Type and Land Cover of Puerto Rico, a Component of the Caribbean Biodiversity Hotspot. *Caribbean Journal of Science*, 38, 165-183.
- Holling, CS. (1973). Resilience and Stability of Ecological Systems. *Annual Review of Ecology and Systematics*, 1-23.
- Hristov, AN, Oh, J, Lee, C, Meinen, R, Montes, F, Ott, T, Firkins, J, Rotz, A, Dell, C, Adesogan, A, Yang, W, Tricarico, J, Kebreab, E, Waghorn, G, Dijkstra, J, & Oosting, S. (2013). Mitigation of Greenhouse Gas Emissions in Livestock Production. In P. J. Gerber, B. Henderson, & H. P. S. Makkar (Eds.), *A review of technical options for non-CO2 emissions*. Rome, Italy: FAO.
- Hunter, JM, & Arbona, SI. (1995). Paradise Lost: An Introduction to the Geography of Water Pollution in Puerto Rico. *Social Science & Medicine*, 40(10), 1331-1355.

- Idso, SB, & Kimball, BA. (1997). Effects of Long-Term Atmospheric CO₂ Enrichment on the Growth and Fruit Production of Sour Orange Trees. *Global Change Biology*, 3(2), 89-96.
- Inter-American Development Bank. (2014). Agriculture and Future Climate in Latin America and the Caribbean: Systemic Impacts and Potential Responses. (D. R. M. Division, Trans.) *In Discussion Paper No. IDB-DP-329, Climate Change and Sustainability Division, Environment, Rural Development*.
- Intergovernmental Panel on Climate Change. (2014). Climate Change Impacts, Adaptations, and Vulnerability *Summary for Policy Makers* (Vol. Annual Report 5).
- Izaurrealde, RC, Thomson, AM, Morgan, JA, Fay, PA, Polley, HW, & Hatfield, JL. (2011). Climate Impacts on Agriculture: Implications for Forage and Rangeland Production. *Agronomy Journal*, 103 371-381.
- Jaramillo, J, Chabi-Olaye, A, Kamonjo, C, Jaramillo, A, Vega, FE, Poehling, HM, & Borgemeister, C. (2009). Thermal Tolerance of the Coffee Berry Borer *Hypothenemus Hampei*: Predictions of Climate Change Impact on a Tropical Insect Pest. *PLoS ONE*, 4(8), e6487.
- Jaramillo, J, Muchugu, E, Vega, FE, Davis, A, Borgemeister, C, & Chabi-Olaye, A. (2011). Some Like It Hot: The Influence and Implications of Climate Change on Coffee Berry Borer (*Hypothenemus Hampei*) and Coffee Production in East Africa. *PLoS ONE*, 6(9), e24528. doi: 10.1371/journal.pone.0024528
- Karl, TR. (2009). *Global Climate Change Impacts in the United States*: Cambridge University Press.
- Kennaway, T, & Helmer, E. (2007). The Forest Types and Ages Cleared for Land Development in Puerto Rico *GIScience & Remote Sensing*, 44(4), 356-382.
- Kimball, BA, Idso, SB, Johnson, S, & Rillig, MC. (2007). Seventeen Years of Carbon Dioxide Enrichment of Sour Orange Trees: Final Results. *Global Change Biology*, 13(10), 2171-2183.
- Kristjanson, P, Reid, RS, Dickson, N, Clark, WC, Romney, D, Puskur, R, Macmillan, S, & Grace, D. (2009). Linking International Agricultural Research Knowledge with Action for Sustainable Development. *Proc Natl Acad Sci U S A*, 106(13), 5047-5052. doi: 10.1073/pnas.0807414106
- Kunkel, KE, Stevens, LE, Stevens, SE, Sun, L, Janssen, E, Wuebbles, D, Konrad, CE, Fuhrman, CM, Keim, BD, Kruk, MC, Billet, A, Needham, H, Schafer, M, & Dobson, JG. (2013). Regional Climate Trends and Scenarios for the U.S. National Climate Assessment *Part 2. Climate of the Southeast U.S.* (pp. 142-142, 194 pp.): NOAA Technical Report NESDIS
- Larsen, MC, & Román, AS. (2013). Mass Wasting and Sediment Storage in a Small Montane Watershed: An Extreme Case of Anthropogenic Disturbance in the Humid Tropics *Geomorphic Processes and Riverine Habitat* (pp. 119-138): American Geophysical Union.
- Larsen, MC, & Webb, RMT. (2009). *Potential Effects of Runoff, Fluvial Sediment, and Nutrient Discharges on the Coral Reefs of Puerto Rico* (Vol. 25). West Palm Beach, Florida.
- Lau, C, Jarvis, A, & Ramirez, J. (2013). Colombian Agriculture: Adapting to Climate Change *CIAT Policy Brief No. 1*. Cali, Colombia: Centro Internacional de Agricultura Tropical (CIAT).

Caribbean Region

- Lewsey, C, Cid, G, & Kruse, E. (2004). Assessing Climate Change Impacts on Coastal Infrastructure in the Eastern Caribbean. *Marine Policy*, 28, 393-409.
- Lin, B. (2011). Resilience in Agriculture through Crop Diversification: Adaptive Management for Environmental Change. *Bioscience*, 3(61), 183-193.
- Little, EL, & Wadsworth, FH. (1964). Common Trees of Puerto Rico and the Virgin Islands. Washington D.C.: U.S. Department of Agriculture Forest Service.
- López, T, Aide, TM, & Thomlinson, JR. (2001). Urban Expansion and the Loss of Prime Agricultural Lands in Puerto Rico. *Ambio*, 30(1), 49-54.
- Lugo, AE. (2000). Effects and Outcomes of Caribbean Hurricanes in a Climate Change Scenario. *The Science of the Total Environment*, 262, 243-251.
- Lugo, AE. (2005). “Los Bosques.” in Biodiversidad De Puerto Rico. Vertebrados Terrestres Y Ecosistemas. . In R. L. Joglar (Ed.), *Editorial Del Instituto De Cultura Puertorriqueña* (pp. 395-548). San Juan, PR.
- Macdonald, LH, Anderson, DM, & Dietrich, WE. (1997). Paradise Threatened: Land Use and Erosion on St. John, Us Virgin Islands. *Environmental Management*, 21(6), 851-863.
- Manning, B, Mamayek, S, Ding, X, & Bunyavirosh, C. (2013). *Aquaponic Systems in Puerto Rico: Assessing Their Economic Viability*. Research project submitted to the Worcester Polytechnic Institute.
- Marshall, NS. (2010). Understanding Social Resilience to Climate Variability in Primary Enterprises and Industries. *Global Environmental Change*, 20(1), 36-43.
- Martinuzzi, S, Gould, WA, & Ramos Gonzalez, OM. (2007). Land Development, Land Use, and Urban Sprawl in Puerto Rico Integrating Remote Sensing and Population Census Data. *Landscape and Urban Planning*, 79(3), 288-297.
- Mimura, N, Nurse, L, McLean, RF, Agard, J, Briguglio, L, Lefale, P, Payet, R, & Sem, G. (2007). *Small Islands. Climate Change 2007: Impacts, Adaptation and Vulnerability*. Cambridge, UK: Cambridge University Press.
- Mintz, SW. (2007). *Caribbean Transformations*: Transaction Publishers.
- Monclova, H. (2014a). Can Puerto Rico Revive Agriculture? *Caribbean Business Edition*, 42-16.
- Monclova, H. (2014b). P.R. Agriculture Tackling Drought’s Impact on Agrarian Production. *Caribbean Business Edition*, 42-30.
- Muller, A. (2009). Benefits of Organic Agriculture as a Climate Change Adaptation and Mitigation Strategy for Developing Countries. *Discussion Paper. Environment for Development (EfD)*.
- National Agricultural Statistics Service. (2009a). 2007 Census of Agriculture *Puerto Rico Island and Municipio Data* (Vol. 1, pp. 339). Washington D.C.: U.S. Department of Agriculture.
- National Agricultural Statistics Service. (2009b). 2007 Census of Agriculture *United States Summary and State Data* (51 ed., Vol. 1). Washington D.C.: U.S. Department of Agriculture.

Caribbean Region

- National Agricultural Statistics Service. (2014a). *2012 Census of Agriculture*. Washington DC. : Retrieved from <http://www.agcensus.usda.gov/Publications/2012/>.
- National Agricultural Statistics Service. (2014b). *State and County Profiles*. Retrieved from: http://www.agcensus.usda.gov/Publications/2012/Online_Resources/County_Profiles/
- Negggers, X. (2014). Hydroponic, Organic Farming Grows in P.R. *Caribbean Business Edition*, 42-26.
- Nemeth, RS, & Nowlis, JS. (2001). Monitoring the Effects of Land Development on the near-Shore Reef Environment of St. Thomas, Usvi. *Bulletin of Marine Science*, 69(2), 759-775.
- Nytch, C, Silander, S, Colon-Rivera, RJ, & Gould, WA. (2013). Climate Change and Puerto Rico's Forests. In K. R. Jacobs & E. Diaz (Eds.), *Puerto Rico's State of the Climate 2010-2013: Assessing Puerto Rico's Social-Ecological Vulnerabilities in a Changing Climate*. (pp. 142-157). San Juan, PR. Puerto Rico Coastal Zone Management Program, Department of Natural and Environmental Resources, . NOAA Office of Ocean and Coastal Resource Management.
- Obso, TK. (2006). Ecophysiological Diversity of Wild Arabica Coffee Populations in Ethiopia: Groth, Water Relations and Hydraulic Characteristics Along a Climatic Gradient *Cuvillier Verlag* (Vol. No. 46).
- Ortiz, G. (2011). Impacto Sobre La Producción Agrícola Y Prácticas De Adaptación: La Industria Lechera De Puerto Rico Frente Al Cambio Climático *Guía Curricular del Servicio de Extensión Agrícola*.
- Pan, Q, Wang, Z, & Quebedeaux, B. (1998). Responses of the Apple Plant to CO₂ Enrichment: Changes in Photosynthesis, Sorbitol, Other Soluble Sugars, and Starch. *Australian Journal of Plant Physiology*, 25(3), 293-297.
- Pancham, A, & Kossler, B. (2008). Back to the Garden: Agriculture in the Virgin Islands. St. Croix.
- Parés-Ramos, I, Gould, W, & Aide, T. (2008). Agricultural Abandonment, Suburban Growth, and Forest Expansion in Puerto Rico between 1991 and 2000. *Ecology and Society*, 13(2), 1-19.
- Parton, WJ, Coughenour, MB, Scurlock, JMO, Ojima, DS, Gilmanov, TG, Scholes, RJ, & Hall, DO. (2014). Global Grassland Ecosystem Modelling: Development and Test of Ecosystem Models for Grassland Systems *Scope 56- Global Change: Effects on Coniferous Forests and Grasslands*.
- Parton, WJ, Scurlock, JMO, Ojima, DS, Gilmanov, TG, Scholes, RJ, Schimel, DS, & Kinyamario, JI. (1993). Observations and Modeling of Biomass and Soil Organic Matter Dynamics for the Grassland Biome Worldwide. *Global Biogeochemical Cycles*, 7(4), 785-809.
- Parton, WJ, Scurlock, JMO, Ojima, DS, Schimel, DS, & Hall, DO. (1995). Impact of Climate Change on Grassland Production and Soil Carbon Worldwide. *Global Change Biology*, 1(1), 13-22.
- Philpott, SM, Lin, BB, Jha, S, & Brines, SJ. (2008). A Multi-Scale Assessment of Hurricane Impacts on Agricultural Landscapes Based on Land Use and Topographic Features. *Agriculture, Ecosystems & Environment*, 128(1), 12-20.
- Porch, TG, Smith, JR, Beaver, JS, Griffiths, PD, & Canaday., CH. (2010). Registration of Tars-Ht1 and Tars-Ht2 Heat Tolerant Dry Bean Germplasm Lines. *HortScience*, 45(8), 1278-1280.

Caribbean Region

- Porter, JH, Parry, ML, & Carter, TR. (1991). The Potential Effects of Climatic Change on Agricultural Insect Pests. *Agricultural and Forest Meteorology*, 57(1-3), 221-240.
- Prospero, JM, & Lamb, PJ. (2003). African Droughts and Dust Transport to the Caribbean: Climate Change Implications. *Science*, 302, 1024-1027.
- Puerto Rico Climate Change Council. (2013). State of Puerto Rico's Climate 2010-2013 Executive Summary. Assessing Puerto Rico's Social-Ecological Vulnerabilities in a Changing Climate *Puerto Rico Coastal Zone Management Program* (pp. 27). San Juan, PR: Department of Natural and Environmental Resources, Office of Ocean and Coastal Resource Management (NOAA-OCRM).
- Puerto Rico Environmental Quality Board. (2014). Puerto Rico Water Quality Standards Regulation, as Amended, on August 2014 (pp. 108p, 106 appendices). San Juan, Puerto Rico: Government of Puerto Rico, Office of the Governor.
- Rakocy, JE, Shultz, RC, Bailey, DS, & Thoman, ES. (2004). Aquaponic Production of Tilapia and Basil: Comparing a Batch and Staggered Cropping System. *Acta Horticulturae*, 648, 63-69.
- Ramírez, A. (1998). El Servicio De Extensión Agrícola Y El Desarrollo De La Industria Lechera En Puerto Rico *Reunion Cientifica Anual SOPCA*.
- Reagan, DP, & Waide, RB. (1996). *The Food Web of a Tropical Rain Forest*: University of Chicago Press.
- Samuel, C, & McEntire, DA. (2011). *Emergency Management in the U.S. Virgin Islands: A Small Island Territory with a Developing Program*.
- Setrini, G. (2012). Cultivating New Development Paths: Food and Agriculture Entrepreneurship in Puerto Rico.
- Southeastern Regional Climate Center. (2015). Historical Climate Summaries for Puerto Rico and the Us Virgin Islands. from http://www.sercc.com/climateinfo/historical/historical_pr.html
- Stöckle, C, Nelson, R, Higgins, S, Brunner, J, Grove, G, Boydston, R, Whiting, M, & Kruger, C. (2010). Assessment of Climate Change Impact on Eastern Washington Agriculture. *Climatic Change*, 102(1), 77-102.
- Szmant, AM. (2002). Nutrient Enrichment on Coral Reefs: Is It a Major Cause of Coral Reef Decline? *Estuaries*, 25(4), 743-766.
- Thomlinson, JR, Serrano, MI, Lopez, TDM, Aide, TM, & Zimmerman, JK. (1996). Land-Use Dynamics in a Post-Agricultural Puerto Rican Landscape (1936-1988). *Biotropica*, 525-536.
- Thurston, RW, Morris, J, & Steiman, S (Eds.). (2013). *Coffee: A Comprehensive Guide to the Bean, the Beverage, and the Industry*: Rowman & Littlefield Publishers.
- U.S. Department of Agriculture. (2014a). *Strategic Plan 2014-2018*. Washington D.C.: Retrieved from <http://www.ocfo.usda.gov/usdasp/sp2014/usda-strategic-plan-fy-2014-2018.pdf>

Caribbean Region

- U.S. Department of Agriculture. (2014b). *Us Department of Agriculture Climate Change Adaptation Plan 2014*. Retrieved from http://www.usda.gov/oce/climate_change/adaptation/USDA%20Climate%20Change%20Adaptation%20Plan_Only.pdf
- U.S. Department of Labor. (2013). Puerto Rico Economy at a Glance. from <http://www.bls.gov/eag/eag.pr.htm>
- U.S. Energy Information Administration. (2013a). Puerto Rico Territory Energy Profile. Retrieved February, 2015, from www.eia.gov/state/
- U.S. Energy Information Administration. (2013b). U.S. Virgin Islands Energy Profile. Retrieved February, 2015, from www.eia.gov/state/
- U.S. Geological Survey. (2001). National Water Information System Data. Retrieved 20Oct14, 2014, from <http://waterdata.usgs.gov/nwis/>
- UPRM. (2006). Estimado De Terrenos De Uso Agrícola Para Sostener La Demanda Alimentaria De La Población De Puerto Rico Al 2006 *Hoja de Datos Ambientales*. Mayagüez: Universidad de Puerto Rico.
- van der Hoek, R, Peters, M, Mena, M, Schultze-Kraft, R, Schmidt, A, & Rao, I. (2012, June 6-9, 2012). *Tropical Forages to Enhance Sustainable Intensification of Mixed Systems in Central America and the Caribbean*. Paper presented at the Proceedings 66th Southern Pastures and Forage Crop Improvement Conference, San Juan, Puerto Rico.
- Virgin Islands Department of Agriculture. (2013). Vidua Advises Farmers About Livestock Health Problems Due to Dry Weather [Press release]. Retrieved from http://www.vifresh.com/news_detail.php?detail_id=85
- Vu, JCV, Newman, YC, Allen, LH, Gallo-Meagher, M, & Zhang, MQ. (2002). Photosynthetic Acclimation of Young Sweet Orange Trees to Elevated Growth Co₂ and Temperature. *Journal of Plant Physiology*, 159(2), 147-157.
- Wadsworth, F. (2000). Forest Production for Tropical America: USDA Forest Service.
- Wadsworth, FH. (1951). Forest Management in the Luquillo Mountains. I. Setting. . *Caribbean Forester*, 12, 114-124.
- Wadsworth, FH. (1983). Production of Usable Wood from Tropical Forests. *Ecosystems of the World*.
- Wadsworth, FH, & Zweede, JC. (2006). Liberation: Acceptable Production of Tropical Forest Timber. *Forest Ecology and Management*, 233(1), 45-51.
- Walthall, CL, Hatfield, J, Backlund, P, Lengnick, L, Marshall, E, Walsh, M, Adkins, S, Aillery, M, Ainsworth, EA, Ammann, C, Anderson, CJ, Bartomeus, I, Baumgard, LH, Booker, F, Bradley, B, Blumenthal, DM, Bunce, J, Burkey, K, Dabney, SM, Delgado, JA, Dukes, J, Funk, A, Garrett, K, Glenn, M, Grantz, DA, Goodrich, D, Hu, S, Izaurralde, RC, Jones, RAC, Kim, S-H, Leaky, ADB, Lewers, K, Mader, TL, McClung, A, Morgan, J, Muth, DJ, Nearing, M, Oosterhuis, DM, Ort, D, Parmesan, C, Pettigrew, WT, Polley, HW, Rader, R, Rice, C, Rivington, M, Roskopf, E, Salas, WA, Sollenberger, LE, Srygley, R, Stöckle, C, Takle, ES, Timlin, D, White, JW, Winfree, R,

Caribbean Region

- Wright-Morton, L, & Ziska, LH. (2012). *Climate Change and Agriculture in the United States: Effects and Adaptation. Usda Technical Bulletin 1935.* (Technical Bulletin 1935). Washington, DC.
- Wan, SQ, Hui, DF, Wallace, L, & Luo., YQ. (2005). Direct and Indirect Effects of Experimental Warming on Ecosystem Carbon Processes in a Tallgrass Prairie *Global Biogeochemical Cycles*, 19, GB2014.
- Wedderburn, M, Cherubin, A, & Macdougall, K. (2008). United States Virgin Islands Business Opportunities Report Prepared for the United States Department of the Interior Office of Insular Affairs.