



AgEcon SEARCH
RESEARCH IN AGRICULTURAL & APPLIED ECONOMICS

The World's Largest Open Access Agricultural & Applied Economics Digital Library

This document is discoverable and free to researchers across the globe due to the work of AgEcon Search.

Help ensure our sustainability.

Give to AgEcon Search

AgEcon Search

<http://ageconsearch.umn.edu>

aesearch@umn.edu

*Papers downloaded from **AgEcon Search** may be used for non-commercial purposes and personal study only. No other use, including posting to another Internet site, is permitted without permission from the copyright owner (not AgEcon Search), or as allowed under the provisions of Fair Use, U.S. Copyright Act, Title 17 U.S.C.*

No endorsement of AgEcon Search or its fundraising activities by the author(s) of the following work or their employer(s) is intended or implied.

STA/SI/2

Ag 844h



United States
Department of
Agriculture

Agricultural
Research
Service

Agriculture
Handbook
Number 600

Handbook of Water Harvesting

U.S. GOVERNMENT PRINTING OFFICE: 1973

JUN 5 '73

U.S. GOVERNMENT PRINTING OFFICE: 1973

Abstract

Frasier, G. W., and L. E. Myers. 1983. Handbook of Water Harvesting. U.S. Department of Agriculture, Agriculture Handbook No. 600, 45 p., illus.

Water harvesting, the collection and storage of precipitation runoff, is a method of providing water for animals and domestic use in areas where other means of water supply are not available or feasible to develop. A water-harvesting system is composed of a catchment or water-collecting area, a water-storage structure, and other components such as piping, evaporation control, and fencing. No single method or system is best suited for all sites or water needs. Variability of climate, soils, topography, and water needs require that each system be specifically designed to match local conditions. Many methods and materials for precipitation collection and storage have been developed, but the descriptions are scattered in various scientific, popular, and user-oriented publications. This handbook presents a stepwise guide for the design, selection of materials, installation, and maintenance of water-harvesting systems. All methods and materials described are being used in operational systems for supplying water for domestic animals, wildlife, and, with modifications, for domestic or household use.

Keywords: Water, precipitation, runoff, water harvesting, catchments, water storage, domestic water, evaporation control, rainfall, water quality.

Trade names are used in this publication solely for the purpose of providing specific information. Mention of a trade name does not constitute a guarantee or warranty of the product by the U.S. Department of Agriculture or an endorsement by the Department over other products not mentioned.



**United States
Department of
Agriculture**

Agricultural
Research
Service

Agriculture
Handbook
Number 600

Handbook of Water Harvesting

By Gary W. Frasier
and Lloyd E. Myers

Additional copies of this publication can be purchased from the U.S. Government Printing Office, Washington, D.C. 20402. When ordering by mail, ask for the publication by title and series. For faster service, call the GPO order desk at (202) 783-3238 and charge the publication to your Visa, MasterCard, or GPO Deposit Account. Discounts are available for purchases of more than 100 copies mailed to the same address.

Microfiche copies can be purchased from the National Technical Information Service, 5285 Port Royal Road, Springfield, Va. 22161. For additional information, call NTIS order desk at (703) 487-4650.

U.S. Department of Agriculture
National Agricultural Library
2025

Contents

	Page
Section 1.—Introduction	1
Purpose and scope	1
Definitions	1
History of water harvesting	2
Section 2.—Preliminary considerations	3
Section 3.—Site selection	3
Alternate water sources	5
Forage	5
Soils	5
Topography	5
Vegetation	6
Site accessibility	6
Precipitation	6
Potential expansion of system	6
Single versus multiple units	6
Section 4.—Final design	6
Water requirements	6
Precipitation	7
Catchment runoff efficiency	7
Catchment and storage costs	7
Acceptable risk	7
Size of catchment and storage	8
Example	8
Section 5.—Construction methods and materials— catchments	9
General site preparation	9
Shape of catchment apron	9
Catchment slopes	10
Clearing of catchment apron	10
Dike construction	10
Smoothing and compacting	11
Soil sterilization	11
Asphalt-fabric membranes	12
Description of treatment	12
Area of suitability	12
Runoff efficiency	12
Durability	12
Estimated costs	13
Materials	13
Installation procedure	13
Maintenance requirements	15
Advantages and disadvantages	15
Gravel-covered sheetings	15
Description of treatment	15
Area of suitability	15
Runoff efficiency	16
Durability	16
Estimated costs	16
Materials	16
Installation procedure	16
Maintenance requirements	17
Advantages and disadvantages	17
Paraffin wax	17
Description of treatment	17
Area of suitability	17
Runoff efficiency	18
Durability	18
Estimated costs	18
Materials	18
Installation procedure	18
Maintenance requirements	19

Contents—Continued

	Page
Advantages and disadvantages	19
Miscellaneous catchment treatments	19
Artificial rubber membranes	19
Sheet metal coverings	20
Concrete	20
Sodium salt	20
Section 6.—Construction methods and materials— storage tanks	21
General site preparation	21
Prefabricated tanks	21
Steel rim tanks	21
Steel rim	21
Tank liners	22
Poured concrete bottoms	24
Plastered concrete tanks	25
Membrane-lined reservoirs	26
Section 7.—Construction methods and materials— miscellaneous	29
Evaporation reduction	29
General	29
Roofs	29
Floating covers	30
Catchment and storage conveyance	30
Sediment traps	31
Screens	31
Fences	31
Diversion ditches	33
Piping, valves, and drinking troughs	33
Section 8.—Maintenance	34
General need	34
Specific requirements	36
Section 9.—Water quality	36
Literature cited	38
Appendix 1.—Computation of catchment and storage sizes	40
Description	40
Program instructions	43
Appendix 2.—Test for soil compatibility of the paraffin wax treatment	45

List of Tables

	Page
1. Approximate site requirements, costs, and performance data for field-tested catchment construction materials	4
2. Approximate average costs of water storage tanks in 1980	5
3. Estimates of daily and monthly drinking water requirements for various animals	7
4. Calculation example: First approximation runoff and storage data	8
5. Calculation example: Runoff and storage data for system optimization	9
6. Maximum allowable concentrations of chemical substances for domestic drinking water supplies	36
7. Recommendations for levels of toxic substances in drinking water for livestock	37
8. Guide to the use of saline waters for livestock and poultry	37

List of Tables—Continued

	Page
9. Summary of analysis of elements from samples collected from various water-harvesting catchment surfaces.....	38
10. Listing of program for computing optimum sizes of catchment and storage	40
11. Input data for sizing catchment and storage in example 1 using procedure described in appendix 1	44
12. Results of catchment and storage sizes for example 1 using the procedure described in appendix 1	44
13. Wax treatment suitability relative to water repellency drop evaluation	45

List of Figures

	Page
1. Typical water-harvesting system	1
2. Rock outcropping used as a catchment apron	2
3. Sheet metal catchment on wooden framework	2
4. Irregular shaped asphalt-fiberglass catchment matched to the natural surface topography	6
5. Irregular shaped catchment with lined collection ditches.....	10
6. Cross section of typical lined collection ditch	10
7. Hand raking and smoothing of catchment area	10
8. Recommended shapes and sizes of dikes for a water-harvesting catchment	11
9. Technique for covering buried rocks on a catchment surface	12
10. Compacting a catchment apron with a self-propelled vibrating drum roller	12
11. Compacting a catchment apron with a rubber-tired vehicle	12
12. Suggested order of installing membrane strips on a water-harvesting catchment	14
13. Spraying asphalt emulsion base coat on fiberglass matting for a catchment treatment	14
14. Sketch of fishmouth wrinkle in lap joint of membrane catchment covering	15
15. Brush application of asphalt emulsion seal coat on an asphalt-fiberglass catchment	15
16. Gravel placement on gravel-covered membrane catchment treatment.....	17
17. Paraffin-wax catchment supplying drinking water for cattle	17

List of Figures—Continued

	Page
18. Butyl rubber catchment furnishing livestock drinking water.....	19
19. Butyl rubber catchment destroyed by wind.....	20
20. Inverted V-sheet metal catchment.....	20
21. Concrete catchment for wildlife water.....	20
22. Sketch of storage tank pad preparation	22
23. Typical steel rim specifications	22
24. Details of joint assembly for steel rim tank	23
25. Detail of tank bottom preparation for membrane liners	24
26. Detail of tank rim to protect liners	24
27. Plastic-lined, steel rim tank.....	25
28. Detail of concrete base for a steel rim tank.....	26
29. Cross section of plastered concrete tank	27
30. Burial trench for reservoir membrane lining	28
31. Installation of asphalt-fabric, polyethylene lining in excavated reservoir.....	29
32. Inverted roof cover over steel rim storage tanks ..	29
33. Butyl-lined storage directly connected to catchment apron	30
34. Details of connecting buried conveyance pipe into side of storage tank	32
35. Detail of sediment trap	32
36. Trash screen used with sediment trap	33
37. Trash screen at inlet to conveyance pipe	33
38. Typical animal drinking trough with pole fence to protect water-level valve.....	34
39. Two methods of connecting drinking supply line to storage tank	34
40. Typical buried valve and float arrangement.....	35
41. Removal of plants growing through asphaltic catchment treatment.....	35
42. Asphalt-planking catchment treatment in need of preventive maintenance	35
43. Catchment treatment destroyed by wind because of the lack of preventive maintenance.....	36
44. Flow diagram for entry of monthly rainfall amounts	42
45. Flow diagram for entry of monthly water use amounts	42
46. Flow diagram for computation of catchment and storage sizes	44
47. Flow diagram for computing costs of catchment and storage	45
48. Drop appearance for different degrees of water repellency.....	45

Handbook of Water Harvesting

Gary W. Frasier and Lloyd E. Myers¹

Section 1.—Introduction

Purpose and Scope

This handbook describes some of the methods and materials being used to collect and store precipitation runoff to provide drinking water and to present a step-wise guide for the design, selection of materials, installation, and maintenance of water-harvesting systems. All methods and materials described are being used in operational systems to provide water for domestic animals, wildlife, and, with modifications, for domestic and household use. Sufficient information is available from research and operational catchments to permit reasonable predictions of expected performance and to identify conditions of climate, soil, and topography that can affect the final performance of the systems. With suitable filtration and chlorination, the described systems can provide water for household purposes.

¹Research hydraulic engineer and agricultural engineer (retired), Southwest Rangeland Watershed Research Center, ARS, USDA, 442 East Seventh Street, Tucson, Ariz. 85705.

Definitions

The term "water harvesting" is used to describe the process of collecting and storing water from an area that has been treated to increase precipitation runoff. The collected runoff from rain or snow is stored in some type of tank to supply drinking water for animals and humans or for supplemental irrigation of crops.

A *water-harvesting system* is the complete facility for collecting and storing precipitation runoff. It is composed of a catchment or water-collecting area, a water-storage structure, and various other components such as piping, evaporation control, and fencing (fig. 1). These systems are commonly called trick tanks by personnel of the Department's Forest Service and referred to as wildlife guzzlers by personnel in game and fish departments. No single method or system is best suited for all sites or water needs. Variability of climate, soils, topography, and water requirements requires that each system be specifically designed to fit local site conditions.

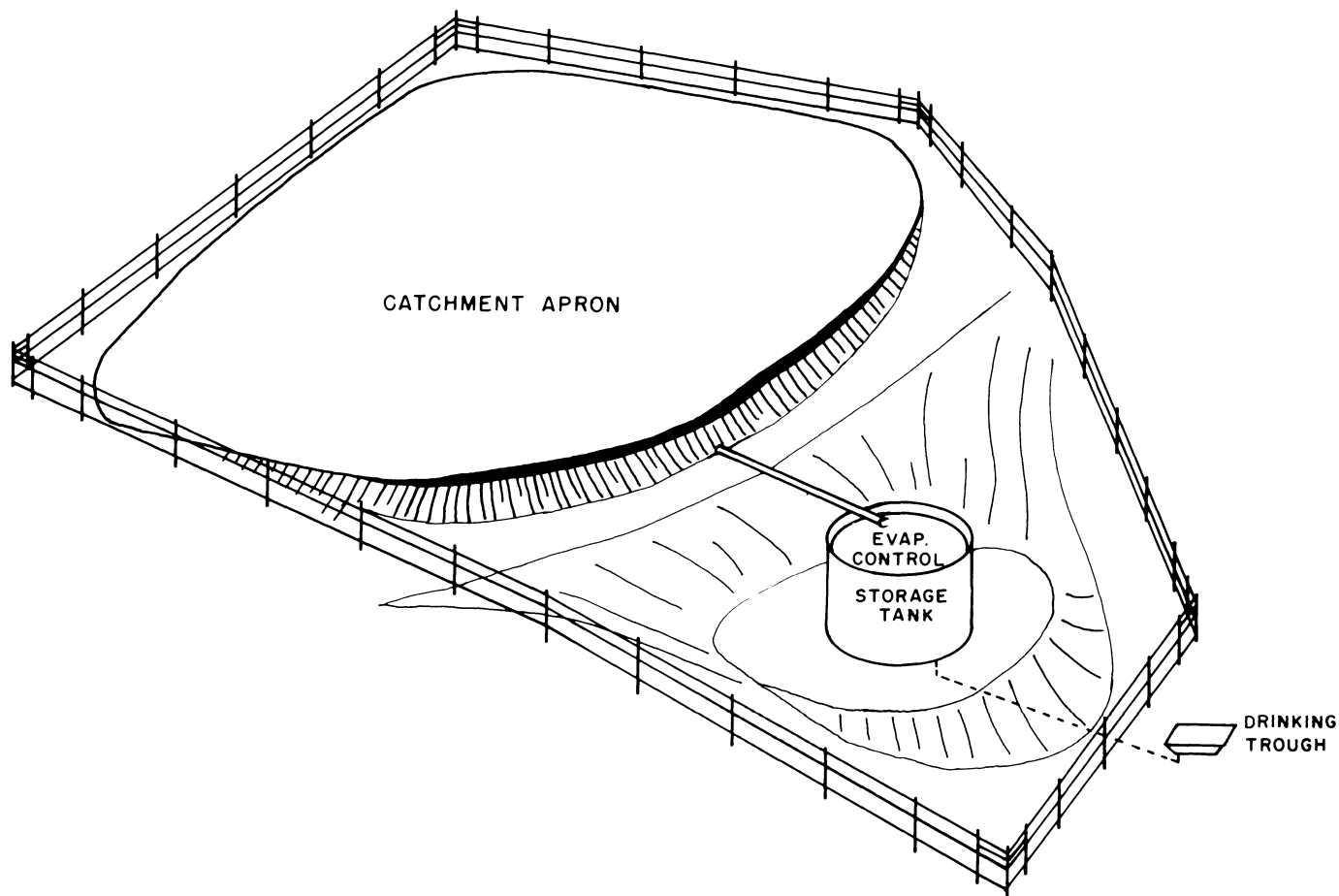

Figure 1.—Typical water-harvesting system.

The *catchment area* is the component of a water-harvesting system that collects and concentrates precipitation. Any area reasonably impermeable to water can be used as a catchment. Large rock outcroppings are natural surfaces potentially suitable for a catchment (fig. 2). Paved highways and roofs of buildings are examples of surfaces designed for other uses which can be modified with gutters for water collection. Most catchment surfaces, however, consist of land that has been cleared of vegetation, smoothed as necessary, and then chemically treated to stop water infiltration or covered with an impermeable sheet of rubber, plastic, asphalt-impregnated fabric, or metal.



BN-49421

Figure 2.—Rock outcropping used as a catchment apron on the Hopi Indian Reservation in northern Arizona.

The *storage tank* is the component of a water-harvesting system that stores the collected water until it is needed. Any container that prevents water loss by seepage is a potential means of water storage. Typical storage tanks are earthen reservoirs, lined pits, and various steel, plastic, concrete, or wooden tanks. The tanks may be completely enclosed or, as on many installations, open at the top. Open-top tanks for water-harvesting systems usually require some means of reducing or preventing water loss by evaporation. Typical evaporation control measures are roofs over the tanks or covers floating on the water surfaces.

History of Water Harvesting

Water harvesting is an ancient method of obtaining water that has received renewed interest in recent years as a viable water supply practice for many regions of the world. Water harvesting is believed to have been developed in ancient Iraq, 4,000 to 6,000 years ago, for supplying water to trade caravans (28).² Over 4,000 years ago, farmers in the Negev Desert of Israel cleared hill-sides to increase rainfall runoff and directed the runoff water to cultivated fields in the valleys (15). There is evidence that similar systems were used 500 years ago

²Italic numbers in parentheses refer to Literature Cited, p. 38.

by the Indians in the southwestern United States (46). Collecting runoff from the roofs of buildings and storing the water in cisterns or tanks is still used in some places as a means of domestic water supply (32).

Some of the first catchments built to collect animal drinking water were rooflike structures of galvanized sheet metal on a wooden frame (fig. 3). The catchments were effective but also relatively expensive. In more recent systems, the metal sections were placed directly on the soil surface (30). Various other materials, such as concrete, tar paper, and asphalt cement, were used as catchment treatments with limited degrees of success. The effective life of many of the installations did not justify the cost of the materials.

During the 1950's, studies were conducted on catchments covered with artificial rubber (butyl) membranes (29). Properly compounded butyl sheetings, when not under tension, exhibited exceptional resistance to deterioration under exposure to sunlight and were relatively simple to install. Unfortunately, many of these installations failed within 5 to 10 years, usually because of wind damage. With proper installation techniques and a periodic maintenance program, butyl-rubber sheetings have been successful on some installations. These butyl-rubber catchments were relatively expensive, and were primarily used by government agencies on public lands. During the 1950's, attempts were also made to use vinyl and polyethylene sheeting for exposed catchment covers. They failed because of damage by solar radiation and wind. Water harvesting was not recognized as a cost effective means of water supply until durable, easily installed, lower cost methods and materials were developed.

In the 1960's, various governmental, private, and university research organizations in the United States and in other arid or semiarid countries initiated studies to develop and evaluate new methods and materials



BN-49422

Figure 3.—Sheet metal catchment on wooden framework.

for constructing water-harvesting systems with lower installation costs and improved system reliability. A major shift in emphasis occurred when researchers at the U.S. Water Conservation Laboratory, Agricultural Research Service (ARS), U.S. Department of Agriculture (USDA), Phoenix, Ariz., began using the soil itself as a catchment surface by treating it with waterproofing and stabilizing materials (34). Many of the studies are still in progress. Numerous individuals and organizations have contributed to the development of the present state-of-the-art knowledge.

Many of the recommendations presented were derived from unreported studies conducted by the authors from 1959 to 1978 at the U.S. Water Conservation Laboratory. Some of the described techniques were developed by ARS scientists in cooperation with personnel of the USDA's Forest Service; U.S. Department of Interior's (USDI) Bureau of Land Management (BLM) and Bureau of Indian Affairs (BIA); and the Arizona Game and Fish Department.

This handbook describes the techniques and materials proved effective in research studies and on about 50 operational water-harvesting systems. Public land managers and private landowners are now routinely installing water-harvesting systems for supplying onsite drinking water for livestock and wildlife. These systems, while relatively expensive, are frequently more cost effective than other means of water supply in remote areas (6).

Section 2.—Preliminary Considerations

Prior to final site selection and design of the catchment and storage tanks, consideration should be given to all possibilities to make sure that lowest cost and most effective system components are not overlooked. Simultaneous consideration must be given to the construction site, the catchment construction materials, the type of storage tank, and all other elements involved in the system design. The approximate location of the construction site is determined by the area in which additional water is needed. Ordinarily, the lowest cost storage tank and catchment construction materials should be selected and a site located that permits their use. Frequently, a survey of the available sites will show that the actual choices are limited.

Table 1 lists information that is helpful in selection of catchment materials. Paraffin wax is a relatively low-cost material, but it will not work on some soils. Should the available sites have those unfavorable soils, asphalt-fabric and gravel-covered sheeting appear to be the next best choices. When gravel is available at the construction site, gravel-covered sheeting can be lower in cost than asphalt-fabric, but gravel-covered sheeting requires a smooth soil surface and flat slopes. Should the available site be steeper than 5 percent, or have a surface that cannot be smoothed, then asphalt-fabric would probably be the best preliminary choice.

Storage tank selection should also be based on the lowest cost structure that will fit the site and store water

with minimum loss. Table 2 presents cost data of interest in making a preliminary selection. This shows that a steel-rim tank, with a concrete bottom and a floating cover, is the lowest cost tank; however, labor was estimated at \$10 an hour. Should lower cost labor and sand be available at the site, a plastered-concrete tank can be lowest in cost. Evaporation losses may not be a problem in high rainfall areas. In this situation, the lowest cost could be a lined earthen tank without a roof.

Approximate size of the water-harvesting system should be considered in preliminary site surveys. Water requirements should be estimated from data in table 3, and average annual precipitation for the past 10 years should be obtained from the rain gage nearest the area needing water. Catchment size can then be approximated by the equation:

$$A = 0.2 \frac{U}{P}$$

where A = catchment area in square yards,
 U = annual water use (requirement) in gallons, and
 P = average annual precipitation in inches.

The total annual water requirements can be used as a preliminary approximation of storage tank size for short periods of water use (1 to 3 months). For longer periods, we can assume that the tanks will fill twice and that storage tank volume can be estimated as one-half the total annual water requirement. These approximate sizes are useful for preliminary surveys but should not be considered as final design.

Other factors must also be considered. Accessibility and availability of equipment, materials, and labor will often determine choices that can be made. General land topography and distance to alternative water sources will influence final system design and should be included in preliminary considerations. The area served can be expanded by using remote watering troughs connected by pipe to the main storage tank, or the system can be located at the junctions of several pastures. These latter factors will enter into determination of water requirements.

There are many different elements in the design of a water-harvesting system. A change in any one of the system components can change the selection or performance of the other components. Accordingly, in the process of making preliminary choices prior to final design, all system design components must be given simultaneous consideration. Failure to do so will result in a system that is too large or too small, costs more than it should, or does not provide the required amount of water when needed.

Section 3.—Site Selection

The site selected for a water-harvesting system will significantly affect the installation costs, performance, and utilization of the facility. Factors to consider when selecting a site are: Alternate water sources, quantity of

Table 1.—Approximate site requirements, costs, and performance data for field-tested catchment construction materials

Treatment	Catchment slope		Soil texture					Air temperature			Catchment surface		Materials ¹	Labor ¹	Approximate average life in years with good maintenance	Design runoff percentage
	3-5 per-cent	5-10 per-cent	Silt	Silt loam >20 per-cent sand	Sandy loam	Sand and loamy sand	Clay and clay loam	Freezing	Summer		Rough	Smooth				
									>90°F	<90°F						
Asphalt-fabric	X	X	X	X	X	X	X	X	X	X	X	X	² \$2.00	³ \$0.50	20	95+
Gravel-covered sheeting	X	O	X	X	X	X	X	X	X	X	O	X	1.75	.80	15	85+
Paraffin wax	X	O	O	X	(⁴)	O	(⁵)	X	X	O	X	X	1.00	.10	7	75+
Artificial rubber membrane	X	X	X	X	X	X	X	X	X	X	O	X	10.00	.50	15	95+
Sheet-metal covering	X	X	X	X	X	X	X	X	X	X	X	X	15.00	—	20	95+
Concrete	X	X	X	X	X	X	X	X	X	X	X	X	20.00	—	20	60+

O = Probable failure.

X = Probable success.

¹Approximate installation cost per square yard on prepared site.

²Based on 1980 materials cost.

³Based on estimated labor cost of \$10/hr.

⁴Treatment should work if clay is nonswelling.

⁵Treatment may work if clay is deflocculated.

Table 2.—Approximate average costs of water storage tanks in 1980¹

Tank type	Tank		Lining		Evaporation control		Total cost	
	Material	Installation ²	Material	Installation ²	Roof	Float cover	Roof	Float cover
Steel-rim tank	\$1,500	\$640						
Elastomeric lining			\$1,960	\$120	\$960	\$350	\$5,180	\$4,570
PVC lining			980	120	960	350	4,200	3,590
Composite lining			780	160	960	350	4,040	3,430
Concrete bottom			200	(³)	960	350	³ 5,300	³ 2,690
Excavated-earthen tank	N.A.	400						
Exposed elastomeric lining			1,840	400	2,010	N.A.	4,650	N.A.
Exposed composite lining			740	800	2,010	N.A.	3,950	N.A.
Buried lining			1,080	1,200	3,840	N.A.	6,520	N.A.
Plastered-concrete tank	⁴ 480	1,720	N.A.	N.A.	1,400	540	⁴ 3,600	⁴ 2,740

¹Based on 20,000-gal tank.

²Labor costs estimated at \$10/hr.

³Hauling distance will influence costs.

⁴Influenced by availability of sand at site.

Note: N.A. = Not applicable.

forage, soil type and depth, land topography, accessibility, and precipitation patterns.

Alternate Water Sources

Permanent water sources will obviously be considered in deciding the approximate location of a water-harvesting site. Intermittent sources should also be considered. Intermittent springs or streams or earthen stock ponds filled by runoff from high-intensity storms may be able to supply some of the water requirements during some part of the year or grazing season. Utilizing these temporary sources of water can, in some places, allow installation of a smaller water-harvesting system. If the watering troughs connected to the water-harvesting systems can be turned off when alternate water sources are available, the catchment-supplied water can be saved for periods when the intermittent sources are dried up. This practice is of major importance during periods of extended drought. All possible water sources should be evaluated with respect to number, location, dependability, and potential quantity.

Forage

The type and quantity of available forage, coupled with the grazing management plan, are major factors in site selection. The water-harvesting system is normally placed in areas inadequately used because of the prior absence of animal drinking water supplies to improve the distribution of the grazing animals and achieve more uniform utilization of forage. In some areas, remote watering troughs, gravity fed by pipelines from the storage, can be used to provide animal dispersion. This technique must be used with caution, because field experience has shown that extended pipelines to remote watering troughs are susceptible to mechanical failure, causing the loss of the stored water.

Soils

Selection of the general area for the water-harvesting system is initially based on forage availability and alternate water-source factors. Frequently, a catchment treatment is desired that requires a specific soil type. The site is then selected using soil type as one of the main criteria. If the required soil type is not present within the general area, the catchment treatment must be changed to a type compatible to the soils at the site. The soil type and depth also affect the kind of water-storage structure that can be installed. For example, if insufficient soil depth and rocks prevent the installation of a partially buried tank near the catchment, an above-ground tank may have to be constructed at some distance from the catchment.

Topography

In addition to specific soil types, some catchment materials have slope angle and length limitations. Premature treatment failure can occur if the treatment is installed on an unsuitable slope. If the slope requirements of a desired material cannot be met, the catchment site must be changed, or a different material must be used for catchment construction.

The effort required to prepare a catchment site can often be minimized by locating the catchment to take advantage of natural surface topography. Shallow natural depressions draining to a central location are one such topographic feature that is usually desirable (fig. 4).

The catchment-to-storage distance can be minimized if the slope increases immediately below the catchment area. This allows the tank to be placed closer to the catchment, which reduces the length of catchment-to-storage conveyance.



BN-49423

Figure 4.—Irregular shaped asphalt-fiberglass catchment matched to the natural surface topography.

Vegetation

Catchment sites covered with vigorous brush growth should be avoided if possible. Clearing is more difficult, and catchment maintenance must usually contend with new growth sprouting from roots that have not been dug out or killed. When the only soil suitable for catchment construction is covered with brush or, for esthetic reasons, the catchment must be hidden in brushy or tree-covered areas, great care should be taken to kill or to dig out and remove all roots.

Site Accessibility

The accessibility of the site for construction equipment is a factor of major economic importance. Sites that are difficult to reach, or that require a four-wheel drive vehicle increase the cost of equipment and labor required and may limit the types of materials that can be used in the installation. In very rough country, the movement of livestock will be restricted by poor site location.

Precipitation

In some locations, local topographic features, such as hills or mountains, can affect precipitation patterns over relatively small distances. When possible, rain shadow areas should be avoided. If significant quantities of the precipitation occur as snow, locating the catchment apron where the snow will accumulate in drifts, or the installation of snow fences to promote drift accumulation on the catchment, may be desirable.

Potential Expansion of System

The final consideration in site selection is to include the possibility of a future expansion of the system to provide additional quantities of water. The water requirement may be increased by changes in the grazing management plan to increase livestock numbers or by the installation of pipelines to remote watering troughs that increase the area served.

Single Versus Multiple Units

Although the unit cost of materials and labor for installation of many water-harvesting systems decreases as the sizes are increased, large water-harvesting systems may not be best for proper management of animals. To promote better distribution of animals, it may be better to build several small systems spaced throughout the grazing area. Multiple units reduce the travel distance of animals, which improves the uniformity of forage utilization. In areas with highly variable spatial rainfall patterns, multiple water-harvesting systems increase the probability that some water will be collected within a given period. Additionally, the failure and loss of water from one part of a multiple system is not as critical as the loss of water from a single system. Since multiple units are usually more costly to construct for the same quantity of water, the land manager must decide if the added water costs will justify the improved management.

Section 4.—Final Design

The final steps in designing a water-harvesting system are to select the methods and materials for constructing the catchment and storage that are best suited to the specific site conditions and to determine the size of the catchment apron and storage tank that will provide the needed water at the lowest total system cost.

Selection of the materials and construction methods should not be attempted without thorough knowledge of the characteristics, advantages, and limitations of the available materials and methods. This information is presented in Sections 5, 6, and 7. Initially, all possible types of methods and materials for the catchment and the storage are considered. The final choice of construction methods and materials will normally be made during the process of site selection. Included in these considerations are such factors as the expected life of the materials, maintenance requirements, availability of labor and equipment for installation, and costs.

Water Requirements

A water-harvesting system must supply the quantity and seasonal distribution of water required. For systems supplying livestock or wildlife drinking water, the total water requirements are based on the type and numbers of animals using the area. Table 3 gives some estimates of the daily and monthly water requirements of various types of animals. These water requirements will be influenced by the climatic conditions and the time of year the system is expected to furnish water. In hot, dry climates, the daily animal water needs are significantly higher than those in cooler climates. Similarly, livestock will require more drinking water in the summer than in the winter.

The quantity of water for domestic household use will vary depending upon the number of people, uses of water, and amount of water conservation practiced. Generally, people require 10 gal/day per person for

cooking, drinking, and washing and 20 to 40 gal/day per person for flush toilets and showers.

Table 3.—*Estimates of daily and monthly drinking water requirements for various animals*

Animal	Daily water requirements	Total water per animal unit month (AUM)
	<i>Gallons per day</i>	<i>Gallons per month</i>
Beef cattle (41): ¹		
Mature animals	8-12	240-360
Cows with calves	10-15	300-450
Calves	5-8	150-240
Dairy cattle (41):		
Mature animals	10-15	300-450
Cows with calves	12-18	360-540
Sheep (41):		
Mature animals	1-2	30-60
Ewes with lambs	1.5-2.5	45-75
Horses (41)	10-12	300-360
Wildlife (42):		
Mule deer	1-2	30-60
Antelope	1-2	30-60
Elk	5-8	150-240
Swine (26)	4	120
Chickens (per 100 head) (26)	4	120
Turkeys (per 100 head) (26)	7	210

¹Italic numbers in parentheses refer to Literature Cited, p. 38.

Any water losses from storage by seepage or evaporation must be included as part of the total water requirement. The magnitude of the seepage and evaporative losses is dependent upon the type and size of the storage tank. Unlined excavated earthen tanks often have seepage losses greater than 1 inch/day. Evaporation losses from open water surfaces in hot desert climates can exceed 0.25 inch/day (4). On a 50-ft-diameter steel tank, evaporation losses could exceed 300 gal/day. Failure to include these losses, or to eliminate them, can result in an undersized system and insufficient water during critical periods.

Precipitation

One of the most difficult parameters to accurately estimate is the quantity of precipitation that will occur during a given period. Monthly averages obtained from long-term precipitation records are the quantities most commonly used. Precipitation records can be obtained from the National Climatic Center, Environmental Data and Information Service, National Oceanic and Atmosphere Administration, U.S. Department of Commerce. In many areas, precipitation extremes (highs and lows) or short-term fluctuations from the mean can be significant and unpredictable. Selection of the high values of precipitation will result in an undersized water-harvesting system that will not be able to supply the required quantities of water. Conversely, an underestimate of rainfall will result in an expensive, oversized catchment and storage. Many areas will have random variations of periods with above-average precipitation (wet) and periods with below-average precipitation (dry).

We recommend a minimum of 10 years of records be used in estimating precipitation quantities. If there are extreme variations in precipitation quantities, data from the two wettest years should be eliminated. When the required information is available, statistical probability techniques can be used to determine the frequency of various precipitation extremes (27, 38). Selecting rainfall amounts based on probability analysis can reduce the chance of designing a system that will be unable to provide the necessary water or, at the extreme, be oversized at unnecessary added costs.

Catchment Runoff Efficiency

The required size of the catchment area is directly affected by the runoff efficiency of the catchment treatment. Some membrane coverings (for example, asphalt-fabric and sheet metal) have, essentially, a 100 percent runoff efficiency. Wax-soil treatments initially yield less than 100 percent runoff, and runoff will decline with time. The system design should include a reduced runoff efficiency to insure that adequate water will be collected as the treatment undergoes normal weathering deterioration. For example, wax may have an initial efficiency of 75 percent, which declines to 50 percent after 5 years. Unless retreatment in less than 5 years is anticipated, the 50 percent runoff efficiency should be used in designing a wax catchment to make sure the system provides adequate water during the fifth year.

Catchment and Storage Costs

The unit construction costs of the catchment and the storage are factors that affect their sizes. With high catchment costs (sheet metal) and low storage costs (plastered concrete), the lowest cost system is one with a small catchment and large storage. Conversely, the lowest cost system with low catchment costs (wax) and expensive storage (closed-top steel tank) are with a large catchment area and a small storage. When several different methods and/or materials are suitable at a specific site, the optimum catchment and storage sizes, and total costs for each of the methods and materials, should be computed to aid in their selection. The costs should include estimates of the labor and equipment requirements involved in preparing the site. Storage costs should include an allowance for evaporation control. The materials and labor cost estimates for the specific treatments are presented in the Methods and Materials sections and summarized in tables 1 and 2.

Acceptable Risk

Sometimes, the demand for water will be reduced during droughts because available forage and the numbers of grazing animals will also be reduced. When short intervals of low water yield can be tolerated, it is usually feasible to install smaller water-harvesting systems.

There may be periods when the precipitation will be significantly less than normal that will result in insufficient water being collected to meet the demands. This problem can be solved by increasing either the catch-

ment area or the storage volume, or both. The user must decide the amount of risk that can be accepted should there be insufficient precipitation during some periods.

Size of Catchment and Storage

A high-density, rotational grazing system often requires a different sized water-harvesting system than may be required if the animals were using the system year round. No single size of catchment and storage will be suitable for all systems. Usually, smaller systems can be installed if the maximum water requirements occur at, or slightly follow, the periods of maximum precipitation. Relatively large systems are required if the maximum-use periods occur during the low rainfall periods.

For most installations, many combinations of catchment and storage sizes will provide the required quantities of water. The lowest total-cost system will be determined by relative unit costs of the catchment and storage, precipitation patterns, and water-requirement patterns. Other factors that affect the relative sizes are the runoff efficiency of the catchment, the effectiveness of the method of evaporation control, and the willingness to accept a limited water supply during periods when precipitation is less than normal. The lowest total-cost system will frequently be one with a reduced storage, which overflows during some periods. The computations necessary for determining the relative sizes of the catchment and storage that will provide the required water at the lowest total cost are not difficult but are tedious and time consuming when considering all possible combinations of precipitation, water requirements, and unit costs.

Optimum catchment and storage tank sizes can be approximated by a series of hand calculations or with a programmable desk-top calculator. There is no one best or lowest cost system design. Within a reasonably narrow range of total costs, several combinations of catchment and tank sizes will provide the water required.

Example

A water-harvesting system for supplying drinking water for livestock and wildlife is to be constructed near Williams, Ariz. There will be 60 cows using the area for 5 months (Nov.-Dec. and Mar.-May) and 30 deer year round. Monthly rainfall is estimated at 10 percent less than recorded at the official weather station in Williams. The cattle require 10 gal/head/day (18,000 gal/month) and the deer, 2 gal/head/day (1,800 gal/month) (table 3). The catchment treatment selected is asphalt-fabric, costing \$2.50/yard², with a runoff efficiency of 95 percent. The storage is a steel-rim tank with a concrete bottom and floating butyl cover. The total storage cost is \$135/1,000 gal.

The first approximation of catchment size is obtained with equation 1 (p. 42).

$$A = 0.2 \frac{U}{P}$$

$$= 0.2 \frac{111,600}{19.8}$$

$$= 1,127, \text{ say } 1,100 \text{ yd}^2.$$

Tank size is approximated by:

$$111,600/2 \sim 55,000 \text{ gal.}$$

Precipitation and water use are listed in columns 2 and 4 of table 4. Calculations begin at the start of the series of months with the lowest water use to give the tank an opportunity to fill before a high-use period begins. June is the start of a low-use period in this example. Catchment runoff (column 3, table 4) is calculated by:

$$R = 5.5 \text{ PAE}$$

where:

R = runoff, in gallons,

P = precipitation, in inches,

A = catchment area, in square yards, and

E = catchment efficiency.

Table 4.—Calculation example: First approximation runoff and storage data

(1) Month	(2) P	(3) R	(4) U	(5) S^1
	<i>Inches</i>	<i>Gallons</i>	<i>Gallons</i>	<i>Gallons</i>
June	0.45	2,586	1,800	786
July	2.79	16,035	1,800	15,021
Aug.	3.06	17,587	1,800	30,808
Sept.	1.44	8,276	1,800	37,284
Oct.	1.26	7,242	1,800	42,725
Nov.	1.08	6,207	19,800	29,132
Dec.	1.98	11,380	19,800	20,712
Jan.	1.98	11,380	1,800	30,292
Feb.	1.98	11,380	1,800	39,872
Mar.	1.80	10,345	19,800	30,417
Apr.	1.35	7,759	19,800	18,376
May	0.63	3,620	19,800	2,196
June	0.45	2,586	1,800	2,982

¹Based on storage tank capacity of 55,000 gal.

The water in storage (column 5, table 4) is then calculated by:

$$S = R + S_p - U$$

where:

S = water in storage at end of month, in gallons,

S_p = storage from previous month, in gallons,

U = water use during month, in gallons.

Runoff and storage are calculated for each month and listed in columns 3 and 5. The computed quantity of water in storage (S) can never exceed the actual size of the storage tank (column 5, table 4), and the excess water is lost from use as tank spill or overflow. Calculations based on the first approximation catchment and storage sizes (1,100 yd² and 55,000 gal) are shown in table 4.

Examination of table 4 shows that the most water in storage was 42,725 gal. A 55,000-gal tank was, obviously, too large. Costs of catchment and tank for the first approximation are:

$$\text{Catchment: } 1,100 \times \$2.50 = \$ 2,750$$

$$\text{Storage Tank: } 55 \times \$135 = \underline{\$ 7,425}$$

$$\text{Total} = \$10,175$$

As a rule of thumb, lowest total cost is often achieved when catchment costs slightly exceed storage costs. Table 4 shows that storage can be reduced by about 12,000 gal, which reduces storage costs by \$1,620. This means the catchment can be increased by

$$1620/2.5 = 650 \text{ yd}^2$$

without increasing the total system cost. Runoff and storage calculations are made using 1,100 + 650 = 1,750 yd² catchment, and 55,000 – 12,000 = 43,000 gal storage tank and are listed in columns 3 and 5 of table 5.

Column 5 shows that the smallest amount in storage was 18,162 gal in May, indicating that storage can be reduced by 15,000 gal. This leaves 3,000 gal as a safety factor in case there is no rain the following June. Calculations are repeated using the same 1,750 yd² catchment with a 28,000-gal storage tank as listed in column 6. These calculations show that the 28,000-gal storage tank should be satisfactory.

Table 5.—Calculation example: Runoff and storage data for system optimization

(1) Month	(2) P Inches	(3) R ¹ Gallons	(4) U Gallons	(5) S ² Gallons	(6) S ³ Gallons
June	0.45	4,115	1,800	2,315	2,315
July	2.79	25,511	1,800	26,026	26,026
Aug.	3.06	27,979	1,800	43,000	28,000
Sept.	1.44	13,167	1,800	43,000	28,000
Oct.	1.26	11,521	1,800	43,000	28,000
Nov.	1.08	9,875	19,800	33,075	18,075
Dec.	1.98	18,104	19,800	31,379	16,379
Jan.	1.98	18,104	1,800	43,000	28,000
Feb.	1.98	18,104	1,800	43,000	28,000
Mar.	1.80	16,459	19,800	39,658	24,659
Apr.	1.35	12,344	19,800	32,202	17,203
May	0.63	5,760	19,800	18,162	3,163
June	0.45	4,115	1,800	20,477	5,478

¹Based on a catchment area of 1,750 yd².

²Based on a storage tank capacity of 43,000 gal.

³Based on storage tank capacity of 28,000 gal.

Total costs now are:

$$\text{Catchment: } 1,750 \times \$2.50 = \$ 4,375$$

$$\text{Storage Tank: } 28 \times \$135 = \underline{\$ 3,748}$$

$$\text{Total} = \$ 8,155$$

System costs have been reduced \$2,020 below the cost of the first approximation system. The cost of the system arrived at by these calculations is not significantly different than the cost of the system determined by a programmable desk-top calculator using the program listed in appendix 1. The computed catchment and storage sizes will supply the needed water, provided that the precipitation equals or exceeds the values used in the calculations. Should the actual precipitation be less than estimated, there may be periods of insufficient water.

Some situations will be more complicated than that presented in the above example, and calculations may not be as simple or as straightforward. Use of the program and procedures outlined in appendix 1 will be preferable in these situations. When a programmable calculator and a knowledgeable operator are available, catchment and storage sizes can be determined more rapidly with the programmable calculator than with the method described above.

Section 5.—Construction Methods and Materials—Catchments

Preparation and construction of the catchment area should be delayed until after completion of the storage tank. This permits better access to the tank construction area and reduces the possibility of runoff from the catchment area interfering with the tank installation. It also allows for the option of site relocation should undetected subsurface conditions, such as rocks, be encountered that would cause unexpected difficulty or expense in installing the water-storage tank.

General Site Preparation

Before installing a catchment treatment, the soil surface should be cleared, smoothed, and compacted; dikes should be constructed around the edges; and a soil sterilant should be applied to prevent any plant re-growth. The amount of site preparation necessary will be determined by the ground surface topography, native vegetation present, soil characteristics, and the type of materials to be used in catchment construction.

Shape of Catchment Apron

There is no standard shape for a catchment surface. To minimize material wastage at the edges, square or rectangular-shaped areas are frequently used with treatments that utilize large sheetings, such as gravel-covered plastic and artificial rubber. Some materials, such as paraffin wax, can be easily installed on irregular-shaped areas. Flexibility in catchment shape allows the utiliza-

tion of natural surface topography to minimize the construction effort (fig. 4). Some catchment treatments are not recommended where overland flow slope lengths are greater than 100 ft. To prevent the collected water from concentrating and eroding channels in the catchment surface (which will ultimately destroy the treatment), the catchment apron should be fan shaped to minimize the overland flow distance and lined with collection ditches to intercept the runoff water (fig. 5). These ditches, lined with materials such as gunite concrete, rubber sheeting, or asphalt-fabric membranes, convey the collected rainwater to the main outlet of the catchment (fig. 6). Usually, the catchment is first shaped to fit the land topography, then the shape is modified as necessary to simplify installation.

Catchment Slopes

The slope of a catchment surface should be only as steep as necessary to cause runoff. Ideally, the catchment slopes should be 3 to 5 percent. Some membrane

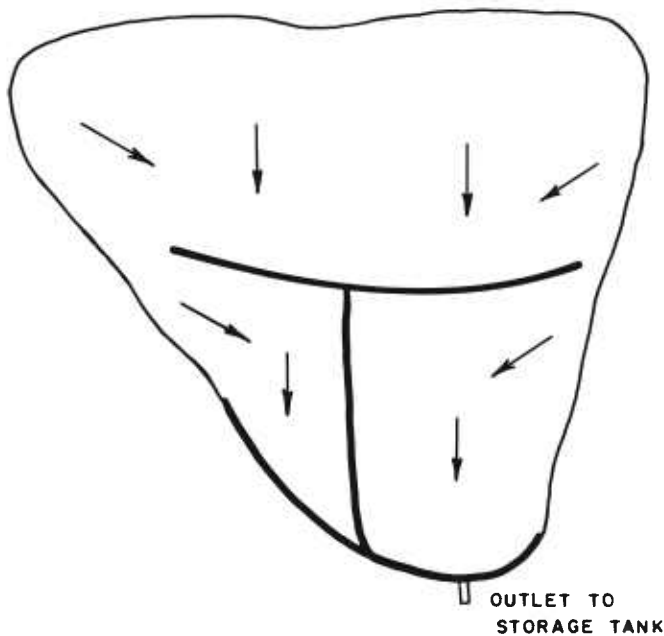

Figure 5.—Irregular shaped catchment with lined collection ditches. Arrows indicate direction of runoff. Heavy lines indicate runoff collection channels.

treatments can be installed on slopes up to 10 percent (table 1). Catchments with less than 3-percent slope may have significant surface retention in small depressions. Treatments with potential erosion problems, such as wax or gravel-covered polyethylene, should not be used on slopes greater than 5 percent.

Clearing of Catchment Apron

The catchment surface must be cleared of vegetation, stones, or other debris that might reduce the durability of the treatment or retain water on the surface. Clearing is usually done with a bulldozer, motorized road grader, rubber-tired front loader, or a large farm tractor with blade attachments. All shrubs, grass, organic debris, and rocks are removed from the area while minimizing the amount of soil disturbance. Hand raking of the area is usually necessary to remove small sticks, stones, and roots, and to smooth out tire tracks left by the heavy equipment (fig. 7).

Dike Construction

Dikes around the perimeter of the apron are usually necessary to contain the collected water and direct it to the catchment outlet. They are not used to prevent upslope water from running onto the catchment surface. A separate dike, upslope from the catchment, should be constructed if there is danger of uncontrolled upslope



BN-49424

Figure 7.—Hand raking and smoothing of catchment area.

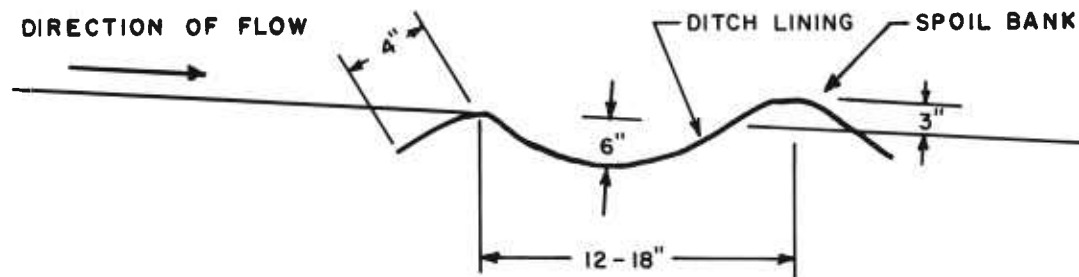

Figure 6.—Cross section of typical lined collection ditch. Spoil bank is composed of material excavated from collection ditch.

runoff damaging the catchment. The dikes should be constructed from soil that does not contain rocks, sticks, or other material that might damage the treatment or prevent firm compaction.

Catchments covered with flexible membranes, such as artificial rubber, must have properly shaped and sized dikes to reduce the possibility of uplift by wind. Wind blowing over improperly shaped dikes can create areas of negative pressure of sufficient force to lift improperly secured membrane treatments from the catchment surface. Small, gradually sloped dikes produce lower values of negative pressure than high, steep-sided dikes (10). General dimensions for approved dikes are shown in figure 8. The dikes on the upper edge and sides of the catchment should have a maximum height of 6 inches. Dikes on the lower edge of the catchment should be a minimum of 12 inches high, or 6 inches higher than the pipe outlet, if it is greater than 12 inches high. The interior sides of the dikes should merge smoothly with the catchment surface. The exterior sides of the dikes, around catchments covered with flexible membranes, should not exceed a slope of 1 (vertical) on 4 (horizontal) (10).

Membrane treatments must be securely anchored at the edges to prevent possible wind damage. Even low-speed winds can cause serious damage if allowed access under the membrane. The membrane edges should be buried in a trench on the top, back edge of the dike with the inside corner of the trench rounded and all loose material compacted or removed. The dimensions of the trench are shown in figure 8.

Smoothing and Compacting

A smooth, firm catchment surface makes installation of the treatment easier, improves the runoff efficiency, increases the life of the treatment, and reduces potential problems of mechanical damage. Following the initial clearing and raking, the catchment surface and dikes should be smoothed and compacted. Depressions that could trap water are filled with soil, and any large rocks within the catchment area that cannot be removed are covered with a layer of soil (fig. 9).

The soil is compacted using steel-lawn rollers filled with water, self-propelled vibrating rollers (fig. 10), or rubber-tired vehicles (fig. 11). The area is rolled twice, once in each direction, then inspected for depressions that could trap water. The depressions are filled with soil and compacted. With dry soil conditions, the area may need sprinkling with sufficient water to wet 4 to 6 inches deep to achieve the necessary compaction density. If time permits, an alternative method is to delay compaction until after the area has received sufficient precipitation to wet the soil. Some soils will compact naturally with alternate wetting and drying from natural precipitation events, but high intensity rainfall may cause erosion on a bare catchment area. Final compaction should result in the smoothest soil surface feasible within the time and resources available.

Soil Sterilization

After clearing and smoothing, the catchment area should be treated with a soil sterilant to prevent recurrent

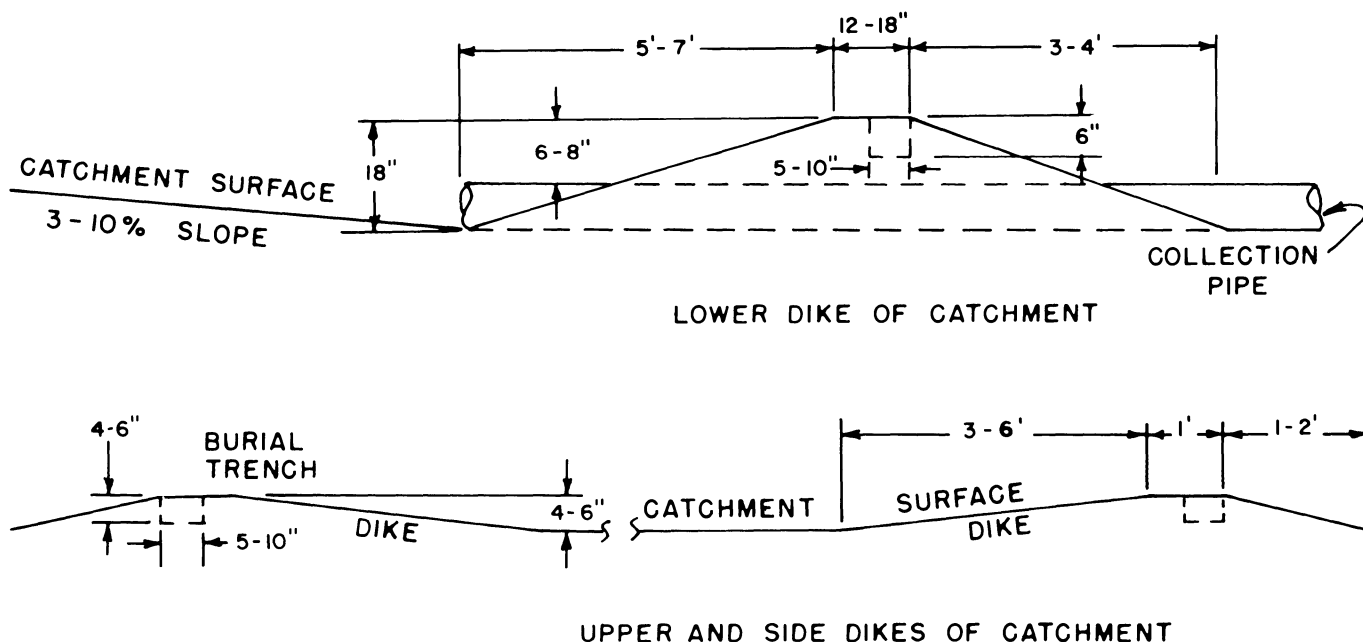

Figure 8.—Recommended shapes and sizes of dikes for a water-harvesting catchment.

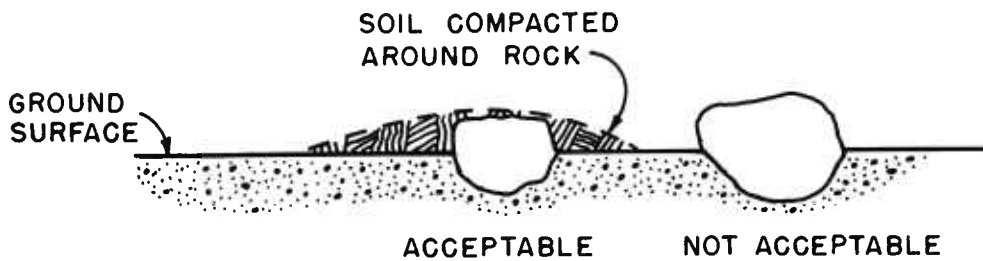

Figure 9.—Technique for covering buried rocks on a catchment surface.



BN-49425

Figure 10.—Compacting a catchment apron with a self-propelled vibrating drum roller.



BN-49426

Figure 11.—Compacting a catchment apron with a rubber-tired vehicle.

growth of plants. The sterilant should be a type that is immobilized within the soil profile and will not contaminate the runoff water. Specialists from local agricultural extension services, universities, or nurseries should be consulted for the types of soil sterilants best suited for soil, vegetation, and climate of the area.

Soil sterilants should be applied in sufficient quantities, and with adequate carrier fluid, to penetrate into the soil to kill any living roots or new plants growing from buried seeds. Some sterilants require an advance application to allow time for the chemical to be translocated into the plant root system. Any deep-rooted, persistent shrubs

or brush should be individually treated. Soil sterilants that use water as a carrier fluid can be applied during compaction.

Asphalt-Fabric Membranes

Description of Treatment

This treatment is a field-fabricated membrane of an inert fabric saturated in-place on the prepared catchment surface with a water-based asphalt emulsion. The water in the asphalt emulsion partially softens the fabric, allowing the membrane to conform to irregularities on the catchment surface. The asphalt emulsion soaks through the fabric to bond a layer of soil to the underside of the membrane, which provides additional weight to the covering. During the curing process, the asphalt hardens, forming a semirigid membrane with high tear strength. The asphalt cements the fabric threads and seals the pore spaces.

Area of Suitability

Asphalt-fabric membranes are presently being used on operational catchments in the hot, arid climate of the southwestern United States, cold mountainous regions of Colorado and New Mexico, and humid tropical regions of Hawaii. The treatment is not restricted to specific soil types and has been successfully installed on relatively loose sandy soils, soils with a high percentage of swelling clays, and soils with a predominance of large buried rocks or exposed rock outcroppings (35).

Runoff Efficiency

On a properly prepared, smooth catchment surface, the asphalt-fabric membrane has a runoff efficiency of nearly 100 percent. For design purposes, the runoff efficiency is assumed to be 95 to 98 percent to compensate for uneven surfaces causing storage in depressions (23).

Durability

Properly installed and maintained asphalt-fabric membranes are highly resistant to mechanical damage and deterioration by weathering processes. The asphalts slowly oxidize when exposed to sunlight. The asphalt oxidation byproducts are washed from the catchment surface by rainfall, which necessitates applying a new

asphalt topcoat every 3 to 5 years. The asphalt remains soft and tacky for a few days following application, but it is possible to walk on the surface during the cool portions of the day.

For 1 to 2 days after installation, the covering is semi-flexible and potentially susceptible to damage by high winds. The asphalt slowly hardens, and within 6 to 12 months, the membrane becomes semirigid and resistant to mechanical damage. Wheeled vehicles have been driven across the surface of several operational catchments without causing serious damage to the membrane. On several asphalt-fabric catchments (fig. 4), intentionally left unfenced, cattle and deer have walked on the surfaces without causing any damage. The material, with proper maintenance, has a projected life in excess of 20 years.

Estimated Costs

The initial cost of materials in 1981, including the seal coat asphalt, was approximately \$1.75 to \$2.00/yd². Typical installation time on a prepared site with a crew of four to five persons is 6 hr (24 to 30 work hours) for 10,000 ft². Seal-coat application requires approximately 3 hr for four to five persons (12 to 15 work hours).

Materials

Fabrics. The fabric must have sufficient tear strength to permit unrolling and positioning on the catchment surface, be resistant to deterioration by ultraviolet radiation (sunlight) and acids or alkalis normally found in soils, be chemically compatible with asphalts, and not swell or wrinkle when coated. The fiber-binding agent should be sufficiently water soluble to permit the fabric to conform to the catchment surface irregularities when prewetted with water or saturated with asphalt emulsion. The fabric should be temperature stable with less than 1 percent shrinkage after placement on the catchment surface.

Two general types of fabrics have been used on operational water-harvesting catchments—a chopped fiberglass matting and a polyester engineering-filtration fabric. The fiberglass matting consists of chopped strands of glass fibers bonded in a random pattern with a highly water-soluble polyester binder with a matting thickness designated at 1 to 1.5 oz/ft² of glass. The engineering-filtration fabric used is a synthetic polyester polymer spun bonded from continuous filaments and mechanically entangled into fabric thicknesses of 60 to 75 mil.

Asphalt. Any asphalt cement, cutback asphalt, or asphalt emulsion that can be applied by brushing or spraying is potentially suitable. Asphalt cement is solid undiluted asphalt that must be heated to about 300°F before it can be applied. Specialized heating and spraying equipment is required. Cutback asphalt is asphalt dissolved in a petroleum solvent. Use of cutbacks is being reduced because evaporation of solvent from large applications is a serious source of air pollution. Asphalt emulsions consist of very small particles of asphalt chemically dispersed in water.

Cutback asphalts and asphalt emulsions should have a minimum of 48 percent solids. Asphalt cements and most cutback asphalts must be heated before applied. Asphalt cements set or solidify very rapidly upon cooling, whereas cutback asphalts require evaporation of the carrier solvent to solidify or set. The type of solvent used in preparing the cutback and the air temperature are the primary factors determining the rate of evaporation and set. Asphalt emulsions usually do not require heating for application and set by evaporation of the water carrier fluid. The rate of asphalt emulsion set is dependent upon the temperature, humidity, rate of air movement, and thickness of the coating.

Some asphalt emulsions undergo separation and coagulation when stored for periods greater than 2 or 3 months. Most asphalt emulsions are irreversibly damaged if stored at temperatures below 40°F. To insure maximum bonding and sealing properties, asphalt emulsions should be obtained no earlier than 30 days before use.

All asphalt deteriorate by oxidation processes although some have added inert fillers or chemicals to retard oxidation. Some asphalt emulsions incorporate chemicals that prevent re-emulsification of the asphalt coating. One asphalt commonly used on operational catchments is a hydraulic foundation clay-based emulsion.

Installation Procedure

Fabric Placement. Excavate the trench for anchoring the edges of the membrane at the top of the dike on the perimeter of the catchment apron. Unroll and position the fabric in a straight line across the lower edge of the catchment apron in front of the catchment outlet pipe (strip 1, fig. 12). Place the ends in and across the bottom of the anchor trench while maintaining sufficient slack, 1ft/100 ft of length (1 percent), to allow for possible shrinkage as the asphalt cures and hardens. Take special care to provide sufficient slack in all directions to prevent the fabric from bridging between high points or at the toe of the dike. After positioning, prewet the strip and coat it with asphalt.

Next, cover the insides of the lower dike with short strips aligned perpendicular to the dike (fig. 12). Precut the strips to the desired lengths, allowing for sufficient material to lay in the burial trench plus an additional 4 to 6 inches for overlap onto the strip previously laid across the bottom of the catchment. Place the strips in position with 4-inch overlaps starting next to the catchment outlet and working both ways. As each strip is positioned, prewet and coat it with asphalt. Make smooth, watertight transition from the catchment surface to the outlet surface by fitting small, prewetted, asphalt saturated strips (4 to 6 inches wide, 12 to 24 inches long) around the structure and filling all spaces. Partially backfill the anchor trench after each strip is coated to hold the edges in place and to prevent wind from penetrating under the sheeting. Then, cover the remainder of the catchment area.

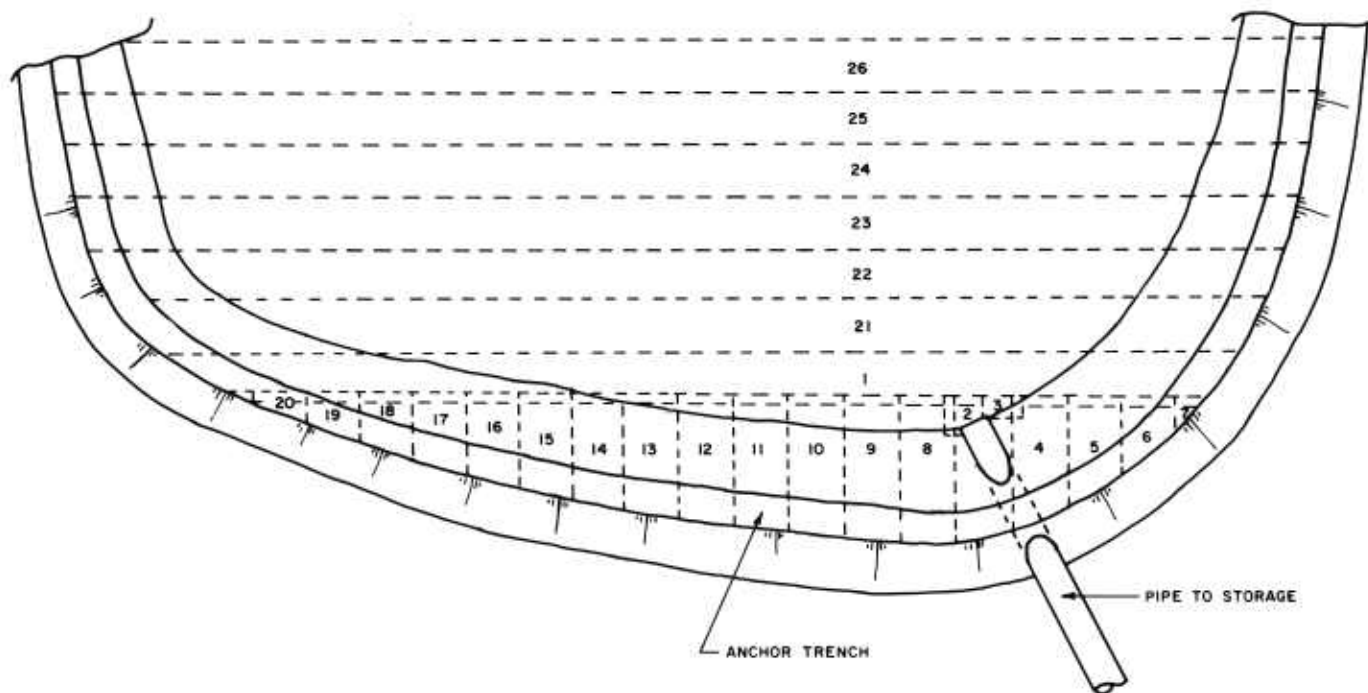

Figure 12.—Suggested order of installing membrane strips on a water-harvesting catchment.

Align the fabric strips perpendicular to the catchment slope. Position each strip with a 4- to 6-inch lap joint so that water flows over the lap and not against the seam. For installations in windy areas, align the fabric strips parallel to the direction of the prevailing wind to reduce the possibility of a catastrophic failure should a lap joint be improperly sealed. Fabrics of wide widths, which are shipped in large rolls, should be unrolled and precut on a smooth, clean area adjacent to the catchment apron, then carried and placed in position.

Asphalt Application. Most synthetic polyester fabrics require prewetting with water to enhance penetration of asphalt emulsions and to aid in softening the fabric for conformity to the soil surface. The prewetting water, containing a household detergent (one cupfull per 200 gal) or wetting agent, is applied uniformly to the fabric at a rate of $\frac{1}{4}$ gal/yd² immediately before application of the asphalt. This prewetting is usually not required with fiberglass matting.

Apply two separate coatings of asphalt. The first coating (base coat) penetrates and saturates the fabric. All asphalt types can be used for the base coat. The second coating (seal coat) seals the surface of the membrane. Use asphalt emulsions with inert fillers (clay emulsion) for the seal coat. Apply asphalt cements, cutback asphalts, and standard road asphalt emulsions directly as supplied. Dilute the clay asphalt emulsions with water (approximately 2 gal/55-gal drum) before application.

Spray or brush the asphalt (fig. 13) onto the fabric. In brush applications, transfer the asphalt from the drum, using 5-gal buckets, pour it on the fabric, and spread it in a uniform coat, using soft bristle floor brooms (18 to

24 inches wide). Because of plugging problems with centrifugal and piston-type pumps, use positive displacement rotary gear pumps for spraying asphalts.

In a single operation, apply sufficient asphalt to saturate the fabric without leaving excess material on the surface. Thick coatings of asphalt do not cure or harden uniformly with depth and can result in shrinkage cracks that may penetrate through the fabric. Once the asphalt starts to set, any additional material will not penetrate into the fabric. Special attention should be taken to insure that the fabric on the dikes is adequately treated and that the asphalt penetrates through all lap joints with good bonds. Even with spray applications, the asphalt should be brushed at all lap joints to insure a positive seal. Asphalt application rates are $\frac{1}{2}$ to $\frac{3}{4}$ gal/yd².



Figure 13.—Spraying asphalt emulsion base coat on fiberglass matting for a catchment treatment.

BN-49427

After the base coat has completely set (2 to 3 days with asphalt emulsion base coats), apply a second coating of the asphalt emulsion to completely seal the fabric and provide a protective weathering surface. Inspect all lap joints before applying the seal coat, and repair any bubbles or "fish mouth" wrinkles that may have formed because of excessive material in the top layer of fabric on a lap joint (fig. 14). Repair wrinkles by cutting them lengthwise and sealing the edges down in an overlap. Areas where there is insufficient fabric to make a good lap should be covered with a small patch.

To insure a positive seal at the seams in the covering, brush on the seal coat, starting at the top of the catchment and working downslope. Apply the seal coat in a uniform coating, insuring that any high points in the fabric caused by surface irregularities are adequately covered and excess material left in low spots or depressions is removed (fig. 15). Asphalt application rate is $\frac{1}{4}$ to $\frac{1}{2}$ gal/yd². Take care to insure adequate covering of the fabric at the edges of the anchor trench. After seal coat is applied, the anchor trench should be completely backfilled and the soil compacted.

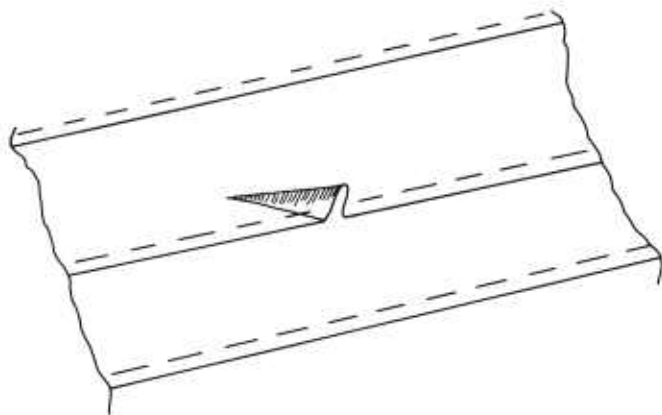

Figure 14.—Sketch of fishmouth wrinkle in lap joint of a membrane catchment covering.



BN-49428

Figure 15.—Brush application of asphalt emulsion seal coat on an asphalt-fiberglass catchment.

Maintenance Requirements

The asphalt-fabric membrane treatment is relatively durable. Maintenance requirements during the first 6 to 12 months are primarily concerned with insuring that all lap joints and edges are properly sealed to prevent wind from gaining access under the membrane. The catchment apron should be inspected 1 to 2 weeks after the seal coat is applied, followed with a scheduled 4- to 6-month interval preventive maintenance program. Small rodents, eating holes at the edges of the membranes, have been a problem. These holes should be patched immediately. New asphalt emulsion seal coats for the entire catchment ($\frac{1}{4}$ to $\frac{1}{3}$ gal/yd²) are usually required at 3- to 5-year intervals. Road grade asphalt emulsion seal coats may require retreatment at shorter intervals.

Advantages and Disadvantages

Advantages. The asphalt-fabric membrane is suitable for use on most soils and under a wide variety of climatic conditions. The membrane is relatively durable and resistant to mechanical damage. With proper maintenance, the treatment has a projected life in excess of 20 years.

Disadvantages. The initial cost of materials for the membrane is relatively high. While not restrictive to use as drinking water for livestock, the runoff water from the asphaltic surface is often discolored by asphalt oxidation byproducts in low rainfall areas with high solar radiation. The water discoloration can be reduced by using high-quality asphalts for the seal coats (asphalt clay emulsion) or by applying special protective coatings to the completed surface (25). At present, protective coatings suitable for application on asphalt surfaces are expensive and may not have sufficient durability to justify the cost.

Gravel-Covered Sheetings

Description of Treatment

This treatment consists of a waterproof membrane, such as polyethylene or roofing tar paper, placed on the prepared catchment surface and covered with a shallow layer of uniform-sized gravel. The membrane provides the impervious surface for collecting the precipitation, while the gravel cover protects the membrane from sunlight weathering processes and provides some resistance to minor mechanical damage. In some installations, an asphalt emulsion tack coat is used to bond the membrane to the soil and/or the gravel to the membrane (33).

Area of Suitability

Gravel-covered sheeting is being used on a limited number of operational catchments supplying livestock water in southwestern United States and northern Mexico. Several catchments have been constructed in Mexico for supplying domestic water for small isolated

villages (44). The treatment is not dependent upon specific soil types but does require a firm, very smooth, rock-and-gravel-free catchment surface. The treatment should be restricted to slopes less than 5 percent to reduce downslope movement of the gravel.

Runoff Efficiency

The average runoff efficiency of the treatment is influenced by the storm type and thickness of the gravel layer. A portion of each rainfall event (up to 0.10 inch) is absorbed by the gravel and lost back to the atmosphere by evaporation. The thicker the gravel layer, the greater the quantity of water retained and lost. The average runoff efficiency is 85 to 90 percent (31). Improper surface preparation or handling of the gravel cover during placement or walking on the finished catchment can puncture small pin holes in the membrane, which will further reduce the runoff efficiency of the treatment.

Durability

Properly installed and maintained gravel-covered treatments are relatively resistant to deterioration by weathering processes. If the gravel cover is disturbed, the underlying membranes will be susceptible to wind damage and sunlight deterioration. Animal foot traffic or burrowing rodents can puncture the membrane. With time, the gravel layer will trap windblown soil and seeds, which can grow and damage the membrane. Similar problems will occur if the gravel is not properly washed and screened. With proper maintenance, expected life of the treatment is from 15 to 20 years.

Estimated Costs

The initial cost of materials is \$0.50 to \$1.25/yd² for a gravel cover ¼ to ½ inch thick (gravel \$20/yd³). An asphalt tack coat to bond the gravel to the membrane would add \$0.25 to \$0.50/yd² to the cost. Typical installation time of the treatment on a prepared site (10,000 ft²), with a crew of four or five persons, is 16 hr (64 to 80 work hours).

Materials

Membrane. Many synthetic rubber and plastic sheetings or films are potentially suitable for use as the underlying membrane. The membrane material must have sufficient tear strength to permit unrolling and positioning on the catchment surface and be relatively resistant to puncturing and propagation of holes or tears. There should be a minimum amount of shrinkage of the material after being unrolled and positioned in a relaxed state on the catchment surface. The membrane materials most commonly used on operational water-harvesting catchments are sheetings of black polyethylene with a minimum thickness of 6 mils (0.006 inch), vinyl sheetings pigmented and 12 to 16 mils thick, or roofing felt, 36 inches wide, 30 lb/100 ft². To reduce handling problems in the field, widths should not exceed 20 ft. Vinyl sheetings and roofing felt are less subject to puncture damage than polyethylene, but they are more expensive.

Gravel. The gravel should be clean material with a uniform diameter of ¼ to ¾ inch (95 to 100 percent passing ¾-inch sieve; <5 percent passing ¼-inch sieve). To reduce the possibility of damaging the membrane during placement, rounded gravel obtained from washed river sediments is recommended. Crushed angular aggregates can cause pinholes in the membrane.

Asphalt. Most types of asphalt emulsions containing a minimum of 48 percent solids, and suitable for application by brushing or spraying, can be used as a tack coat.

Installation Procedure

Gravel-covered membrane treatments should not be used on any slope steeper than 5 percent. The soil surface must be smooth and free from gravel, small sticks, or other materials that can puncture the membrane. The outlet from the catchment must be designed to permit a watertight seal between membrane and pipe, and still retain the gravel covering in place.

Membrane Placement. The trench for anchoring the edges of the membrane is excavated on the catchment apron perimeter. A strip of the membrane material is unrolled and positioned across the lower edge of the catchment with the ends in and across the bottom of the anchor trench. Plastic sheetings are often packaged and shipped with the material partially stretched, and they often shrink as much as 15 percent when unrolled on the catchment surface. Provide sufficient slack in all directions to prevent the material from bridging between high points and at the toe of the dike. Wrinkles in the membrane will not significantly affect the runoff performance of the treatment. Install narrow-width materials (roofing felt) in the sequence used in laying the fabric in the asphalt-fabric treatment. Secure the membrane to the catchment outlet structure with suitable adhesives and/or a clamp and cover with gravel. A 6- to 12-inch edge width is left uncovered to allow for the overlap and seaming of the next sheet. Backfill the anchor trench as each sheet is covered, taking care to insure that there is a good gravel covering on the membrane edges next to the anchor trench. Cover the remainder of the catchment area in sequence with the membrane and gravel.

Align the membrane strips perpendicular to the slope of the catchment and join them with 4- to 6-inch overlaps placed so that the water flows over the joint and not against the seam. Self-adhesive tapes are available for joining sheets of polyethylene and vinyl plastics, and asphaltic mastics can be used for joining roofing felt.

Wind can cause problems in positioning and holding in place large sheets until the gravel cover can be placed. Under windy conditions, place the gravel cover as the material is unrolled and positioned across the catchment. In some installations, to reduce potential wind damage, it may be desirable to align the membrane strips parallel to the direction of the prevailing wind.

Gravel Placement. The gravel can be bonded to the membrane to reduce the possibility of the covering sliding downslope with the runoff water. Brush or spray the asphalt emulsion tack coat to the membrane at a rate of $\frac{1}{4}$ gal/yd² immediately before placing the gravel (37). The gravel must be placed on the treated surface before the asphalt has set.

Spread the gravel covering over the surface in a layer two- to three-particle-diameters thick (fig. 16). Do not place the gravel in piles on the membrane or you will have to rake or smooth the piles to achieve a uniform layer. This could damage the membrane.

For large installations, standard chip-spreading equipment mounted on the rear of dump trucks can be modified to unroll the membrane and place the gravel in a single operation (3). For smaller installations, the gravel is carefully shoveled onto the membrane. Be careful when walking on the membrane to prevent damaging it.



BN-49429

Figure 16.—Gravel placement on gravel-covered membrane catchment treatment.

Maintenance Requirements

Gravel-covered membrane treatments are relatively resistant to deterioration by weathering processes as long as the gravel coverings are maintained. This treatment can be damaged by animal foot traffic, and because of the possibility of making small punctures in the membrane, human foot traffic should be restricted to the minimum necessary for maintenance. Holes from rodents or mechanical sources should be repaired immediately upon discovery. The gravel covering is carefully brushed back from the damaged area, and a patch of the membrane materials is sealed over the damaged area and recovered with gravel.

The entire area should be carefully inspected every 6 months and additional gravel placed in areas where the membrane is exposed. Plant growth on the gravel layer should be removed and the area repaired as necessary.

Advantages and Disadvantages

Advantages. As long as the soil can be smoothed, the gravel-covered membrane treatment is not dependent upon specific soil characteristics and is resistant to weathering deterioration. The treatment is low to moderate in initial cost and can be used in most climates. The runoff water quality is excellent. With proper maintenance, the treatment has a projected life of 15 to 20 years.

Disadvantages. The treatment is susceptible to mechanical damage and must be protected from animals. Plant growth on the gravel cover can be a problem. The gravel layer retains a portion of each precipitation event that is lost to the atmosphere, reducing the average runoff efficiency. The treatment requires a smooth gravel and rock-free surface and should not be used on a soft subbase.

Paraffin Wax

Description of Treatment

This treatment consists of applying a low-melting point paraffin wax, usually sprayed onto a prepared catchment surface in a molten form. The wax may initially remain on the soil surface, but when heated by the sun on successive warm days, the wax penetrates the soil to a depth of $\frac{1}{4}$ to $\frac{1}{2}$ inch, coating each soil particle with a thin wax film and creating an efficient water repellent surface.

Area of Suitability

The paraffin-wax treatment is being used at selected installations in the hotter regions of Arizona for providing livestock drinking water (fig. 17) (6). The climatic areas potentially suitable for the wax treatment are not presently known. At present, this treatment is recommended only for climatic areas where the soil temperature reaches, or exceeds, the melting point of the wax during the warmer seasons of the year.



BN-49430

Figure 17.—Paraffin-wax catchment (foreground) supplying drinking water for cattle.

Paraffin-wax treatments are restricted to reasonably smooth surfaces free of gravel or rocks greater than one-half inch in diameter with slopes of 3 to 5 percent. While catchments with overland flow distances of 200 to 300 ft have been successfully treated with wax, overland flow distances should not exceed 100 ft. Lined interceptor ditches should be provided to reduce flow distances where necessary.

This treatment has been relatively effective on loamy sand soils containing less than 20-percent clays (particle size $<2\mu$). It has not been successful on soils with high clay content or where clay is predominately montmorillonite (expanding type). At present, the physical and chemical properties of soils suited for the wax treatment are not known (17). Representative samples of soil from a potential catchment site must be checked for water-proofing effectiveness with the wax before final selection of the treatment.

Prior to any field installation, tests should be conducted to determine the relative effectiveness of the wax on the specific soil. The Soil Compatibility Evaluation procedure (appendix 2) can be used to determine the potential, initial suitability of the wax treatment. It is not a test for the long-term effectiveness of the treatment, but based on existing field installations, soils rated as good to excellent can usually be successfully treated.

Runoff Efficiency

On compatible soils in a favorable climate, the paraffin-wax treatment will yield 80 to 95 percent runoff. During the colder winter periods, a hardening and crystallization of the wax may cause microscopic cracks in the treated soil layer and reduce the runoff by 10 to 15 percent (21).

Durability

The paraffin-wax treatment is relatively resistant to sunlight deterioration. Initially, the treated soil layer is relatively thin with most of the wax at the soil surface. Some problems have been encountered with winds lifting unmelted wax from the catchment surface, which leaves some areas inadequately treated. This is not a problem for installations made during hot summer periods when 2 to 3 hr of sunshine will heat the soil sufficiently to remelt the wax into the soil.

The wax provides some soil stabilization for 6 to 12 months after installation. The wax soaks a little deeper into the soil with each remelting by the sun. This reduces the stabilization effect of the treatment. Usually, within 2 to 3 years, soil stabilization by wax is negligible, and the treated unstabilized soil may gradually erode from the surface (22).

Inadequate soil sterilization will result in a problem of plant regrowth on the catchment surface. Initially, a good wax treatment will limit the amount of soil moisture available for seed germination and plant use. As the soil surface erodes or cracks, surface soil moisture levels will increase sufficiently to germinate buried seeds or

promote growth of dormant plants. The plant growth further disrupts the integrity of the water repellent layer, allowing additional water to infiltrate, which reduces runoff efficiency. On compatible soils in a favorable climate, and with proper maintenance, the expected life of the treatment is 5 to 10 years.

Estimated Costs

The initial cost of materials is \$0.50 to \$1.00/yd². A significant portion of the installation time is devoted to melting the wax. With the use of small asphalt-distributor trucks or roofing-tar kettles, melting times are usually 0.5 to 1.0 hr/2,000 lb of wax. Typical installation time of the treatment on a prepared site (10,000 ft²), including melting the wax with a crew of three, is 2 hr (total of 6 hr).

Materials

The only material required is a low-melting-point refined paraffin wax (125° to 128° F average melting point (AMP)). Major petroleum refining companies can supply the wax in 11-lb blocks. Several catchments have been treated with high AMP waxes (up to 140° F), but higher-melting-point waxes should be used only in climates where soil temperatures will definitely exceed the wax melting point. There are lower cost partially refined waxes, but at present, information concerning the performance of these lower quality waxes is not sufficient to allow them to be recommended for use in catchment construction.

Installation Procedure

Field experience has shown that the best results are obtained if the wax is applied when there is a high probability that there will be several consecutive days with air temperatures above 90° F. Apply wax to the surface of the prepared catchment area at a rate of 2.5 to 3.5 lb/yd². On large areas (>2,000 yd²), standard asphalt distributor trucks, 1,000- to 3,000-gal capacity, equipped with heaters and large capacity sprayers, are the fastest means of application. Paraffin-wax blocks are placed in the tank and melted. Melting time is reduced by recirculating the molten wax through the tank. As the truck travels across the catchment surface, the molten wax is sprayed onto the soil via the rear spreader bar. The truck speed is adjusted to obtain the required application rate, and successive spray passes are overlapped 3 to 6 inches. This method should not be used on catchments with soft soil surfaces, which will compact under the weight of the truck. The wheel tracks will trap the runoff waters, while ridges of soil will rapidly erode, leaving untreated strips.

Roofing tar kettles, with 100- to 500-gal capacity and equipped with a small pump system (5 to 10 gal/min), can be used for hand-spray application. The melted wax is pumped through a rubber hose ($\frac{3}{4}$ to 1 inch I.D., 50 to 75 ft long) and sprayed through a one- or two-nozzle hand-held spray wand. The spray wand is held 12 to 18 inches above the surface and slowly passed over the

area, insuring uniform coverage. On small catchment areas (<1,000 yd²), the wax can be melted in the tar kettle and applied by hand with small 2-gal sprinkling cans.

Several small catchments have been treated by spreading wax granules or chips on the soil surface and allowing the sun to melt the wax into the soil (16). The catchment area is subdivided into areas of 100 ft², and 30 to 35 lb of the granulated wax is uniformly spread over each sub-area. To insure that the layer of granulated wax is not disturbed by wind before it melts into the soil, this treatment should be applied only during the warmest part of the year. Low-melting-point wax (125° to 135°F) is difficult to cut into chips or granulate at temperatures above 90°. The wax can be chipped with garden-type shredders by precooling the wax to temperatures of 60° or less. To prevent remelting and solidification, chipped wax must be maintained at temperatures of 90° or less during storage and transportation.

On catchments over 100 ft long, or where the combination of catchment slope and length may cause a potential erosion of the treated surface, lined collection ditches are needed to convey the collected water to the outlet. Figure 5 shows the layout of asphalt-fabric lined collection ditches used on an operational catchment.

Maintenance Requirements

The paraffin-wax treatment is relatively resistant to deterioration by sunlight. The area should be fenced to keep out large animals that might damage the treatment. Routine maintenance is normally concerned with restricting and controlling plant growth. Areas damaged by plants or burrowing animals are spot treated with granulated or chipped wax during the hot summer periods.

Advantages and Disadvantages

Advantages. The paraffin-wax treatment is relatively low in cost. Runoff efficiency is excellent on suitable soils in a favorable climate. Each time the soil temperature reaches the melting point of the wax, the treatment penetrates deeper into the soil, creating a thicker water-repellent layer. Water quality is excellent, and with proper maintenance, the treatment has a projected life span of 5 to 10 years before major retreatment is required.

Disadvantages. The treatment requires a surface free of rocks greater than one-half inch in diameter and is restricted to favorable soil types and climates. The wax does not provide significant soil stabilization, and on large catchments, lined collection ditches are often needed to reduce potential soil erosion. Specialized equipment for melting and applying the wax is required.

Miscellaneous Catchment Treatments

Numerous materials are potentially suited for, or have been used for, covering or sealing a catchment surface.

These materials may not be well known or may not be in general use because of high cost, limited durability, sophisticated equipment and techniques required for installation, extensive maintenance, or lack of data defining the area (soils and climate) of potential applicability. The following is a brief discussion of some of these methods or materials that are potentially suitable in some installations as an alternative catchment treatment.

Artificial Rubber Membranes

Artificial rubber (butyl) membranes were used extensively for catchment apron coverings in the 1950's and 1960's (fig. 18) (29). These membranes were relatively easy to install and, based on results from accelerated weathering tests, had a projected life expectancy in excess of 20 years. Unfortunately, many of these installations did not perform to original expectations. The initial membranes, made of nonreinforced sheetings of vulcanized butyl, 30 to 60 mils thick, rapidly deteriorated when installed over surface irregularities, which induced localized tensile stresses (8). The incorporation of a reinforcing fabric of nylon or cotton in the sheetings reduced, but did not entirely solve, the stress deterioration problem.

Artificial rubber fabrics are flexible membranes and are susceptible to wind damage. Holes caused by rodents or birds and by wind vibrating the sheeting against the ground, allow wind access under the covering, which can lift the covering from the surface (fig. 19). Improper installation techniques have contributed to many failures (9).

Properly installed and maintained artificial rubber membranes can be effective catchment treatments, yielding



BN-49431

Figure 18.—Butyl rubber catchment furnishing livestock drinking water near Phoenix.



BN-49432

Figure 19.—Butyl rubber catchment destroyed by wind.

98 to 100 percent runoff with a probable life of 10 to 20 years. Materials specifications have been developed by the American Society of Agricultural Engineers (1). The membranes should be installed in a relaxed condition on smooth catchment surfaces and protected from wind vibration and uplift. The membrane, susceptible to mechanical damage, must be fenced to keep large animals off it. It should be inspected frequently and any damage caused by rodents or mechanical sources repaired immediately. As of 1981, material costs were \$5 to \$10/yd².

Sheet Metal Coverings

Early sheet metal catchments consisted of an above-ground wooden framework in the shape of an inverted roof covered with corrugated sheet metal (fig. 20). These catchments were durable, effective water collectors, but the cost of materials and labor of constructing the support framework has limited widespread acceptance. Several aboveground sheet metal catchments have been damaged by heavy snow loads.

Small catchments of sheet metal on a wooden framework on the soil surface have been constructed to furnish drinking water for wildlife. In some areas, salts in the soil will corrode the metal from the underside. Catchments covered with thin gage (<20 gage) metal have been damaged by foot traffic.



BN-49433

Figure 20.—Inverted V-sheet metal catchment in Hawaii.

Sheet-metal catchments are relatively durable and yield 95 to 100 percent runoff (30). With a washed gravel sub-base or a supporting framework holding the metal above the ground, the covering can be used on most soil types with a minimum of site preparation. The sheet metal must be coated (galvanized) to prevent rusting. Aluminum sheeting can be used if properly supported. Maintenance requirements are primarily concerned with insuring that the sheets are held firmly in place. Wind can seriously damage the catchment if it is allowed to penetrate under a sheet at a loose edge. Initial cost of materials, including support framework, is \$8 to \$15/yd². When using thin sheet metal, the catchment must be fenced to keep out large animals. Life expectancy of the catchment is in excess of 20 years.

Concrete

Concrete has been used on relatively small units (fig. 21), primarily because of the cost of materials and the labor required for installation. Runoff efficiency is 60 to 85 percent (23). Shrinkage cracks in the concrete reduce the runoff efficiency (18). The treatment is very durable and resistant to mechanical damage and probably would not need to be fenced. Cracks should be sealed with some type of crack sealer at appropriate intervals.



BN-49434

Figure 21.—Concrete catchment for wildlife water near Phoenix.

Only high-quality concrete, properly proportioned and with proper curing techniques, should be used. Initial cost of materials, including reinforcing wire, is \$10 to \$20/yd² for a 4-inch-thick slab. Projected life of the treatment is greater than 25 years.

Sodium Salt

A high rate of sodium salts mixed into the soil surface is a potential low-cost treatment that has been used on a limited number of installations in Arizona. The salt, sodium chloride (NaCl), or sodium carbonate (Na₂CO₃), is mixed in the top 2 to 3 inches of soil at a rate of 5 tons/acre, wetted, and compacted. The sodium in the

salt disperses the clay, which plugs the soil pores and reduces water infiltration. On suitable soils, the runoff efficiency is initially 50 to 75 percent (14). At present, the long-term runoff efficiency and the physical and chemical properties of soils suited for the treatment are not known.

Section 6.—Construction Methods and Materials—Storage Tanks

General Site Preparation

The storage tank should be the first item installed on a water-harvesting system. This allows the option of site relocation should undetected subsurface conditions, such as rocks and consolidated soil layers, be encountered that would cause significant difficulty or expense in installing the water-storage tank. Most water-storage facilities used on water-harvesting systems are aboveground or partially buried open-topped, vertical-walled steel, wood, or concrete tanks. Membrane-lined pits, artificial rubber bags, and totally enclosed steel tanks have been used on selected installations.

The type of storage used depends on the topographical and soil characteristics of the site plus the labor, materials, and funds available for construction. Tall, aboveground tanks are usually unsuitable for water-harvesting systems located on gently sloping land. For example, on land with a 5-percent slope, a 10-ft high tank would have to be located more than 200 feet downslope from the catchment. To shorten the distance between catchment and storage on sites with gentle slopes (3 to 10 percent), the storage should be some type of a low-profile tank, partially buried tank, or lined reservoir. The catchment-to-storage distance can be reduced by selecting sites that have an increase in ground slope immediately below the catchment area. Tanks should not be located on unconsolidated fill or soil that may compact and settle with time.

The amount of site preparation necessary to install the storage tank is a factor of the ground topography, soil characteristics, and type of tank. For vertical-walled tanks, a firm, smooth, level base is prepared. When installing partially buried tanks, the soil is excavated to the desired depth with a 3- to 6-ft clearance on all sides for construction access, with the excavation sides sloped to prevent soil from sliding into the work area (fig. 22). On sites where the soil may compact under load, a minimum of 4 inches of gravel fill is placed over the area, wetted, and then compacted prior to tank assembly. Excavated pit storages should have smooth, uniform side slopes of firmly compacted soil. Exposed rocks or rock ledges must be removed, and the resulting small depressions filled with soil. During the site preparation, a trench for the outlet pipe from the storage to the drinking trough, or other point of use, is excavated, the pipe laid in place, and the trench backfilled and compacted.

Prefabricated Tanks

A variety of wood, steel, or fiberglass prefabricated tanks with capacities of 5,000 to 100,000 gal are potentially suitable for use on water-harvesting systems. Small tanks (<20,000 gal) are often preassembled and transported to the site intact. Surplus railroad tank cars have been used for storage on some water-harvesting installations. Larger capacity tanks usually require onsite assembly from preshaped pieces. Steel tanks can be of bolted or welded construction with an integral bottom, with or without a roof.

Another type of prefabricated storage is bags constructed from sheets of artificial rubber. The bags are formed by seaming the sheets into a single unit (one-piece bag) or using two flat sheets and burying the edges in a trench above the waterline (two-piece bag). The bags are usually supported in an excavated pit. These bags are susceptible to damage by rodents; problems have been encountered also with rainwater and snow accumulating on top of the bag and blocking the inlet (9).

Prefabricated storages are relatively expensive with typical costs of \$200 to \$400 per 1,000 gal. Small pre-assembled tanks are simple to install and involve preparation of a suitable base or pad and positioning the tank. Prefabricated tanks of steel, wood, or fiberglass commonly have a projected life in excess of 20 years. Projected life of artificial rubber bags is less because of their low resistance to mechanical damage.

Steel Rim Tanks

These tanks consist of a vertical-wall, cylindrical steel rim with a waterproof liner or bottom. Typical capacities range from 5,000 to 80,000 gal (3 to 15 ft high, 15 to 45 ft in diameter) and are used for aboveground or semi-buried installations.

Steel Rim

Materials. The tank sides are formed from flat or corrugated steel (10 to 16 gage) sheets rolled to the required radius of curvature and zinc coated or similarly treated to prevent rusting. Rims constructed from thin sheets (14 to 16 gage) should have a reinforcing ring of angle iron (1¼ by 1¼ by ⅛ inch) fastened at the upper and lower edges of the tank to provide additional structural stability. Noncorrugated sheets will require vertical stiffeners at 8- to 12-ft intervals around the tank circumference. Figure 23 shows a typical steel rim. Many steel-fabricating companies can supply the steel rims. Steel-grain bins have been used on some water-harvesting installations (13).

Assembly. The sections are bolted or welded together, as specified by the manufacturer, on the prepared site. The finished structure must be in proper alignment and grade. For bolted tanks without a supplemental interior lining, an asphaltic mastic joint sealer is placed in all vertical and circumferential seams, and the bolts are

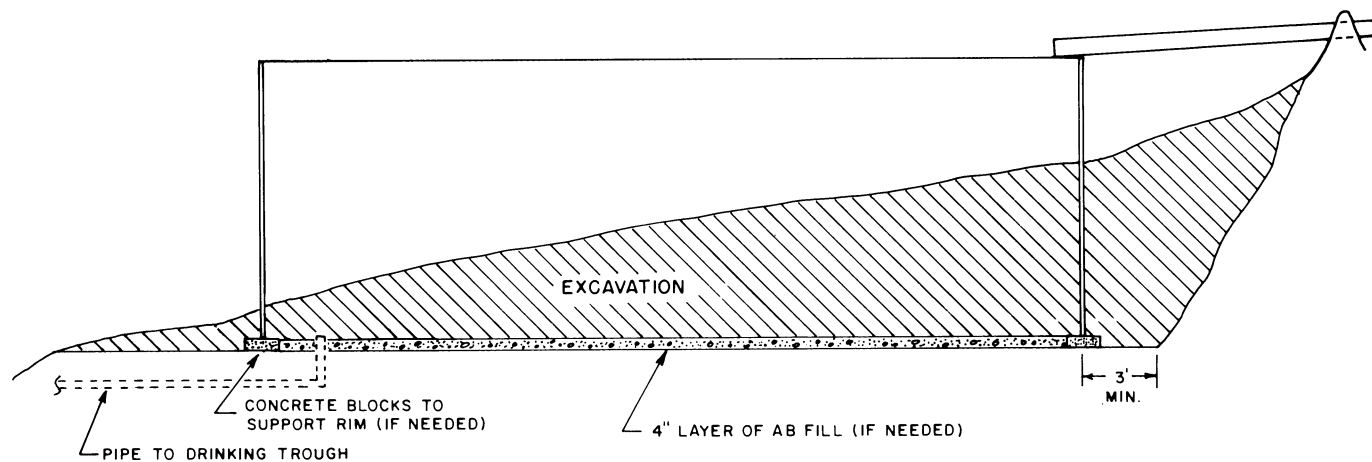

Figure 22.—Sketch of storage tank pad preparation.

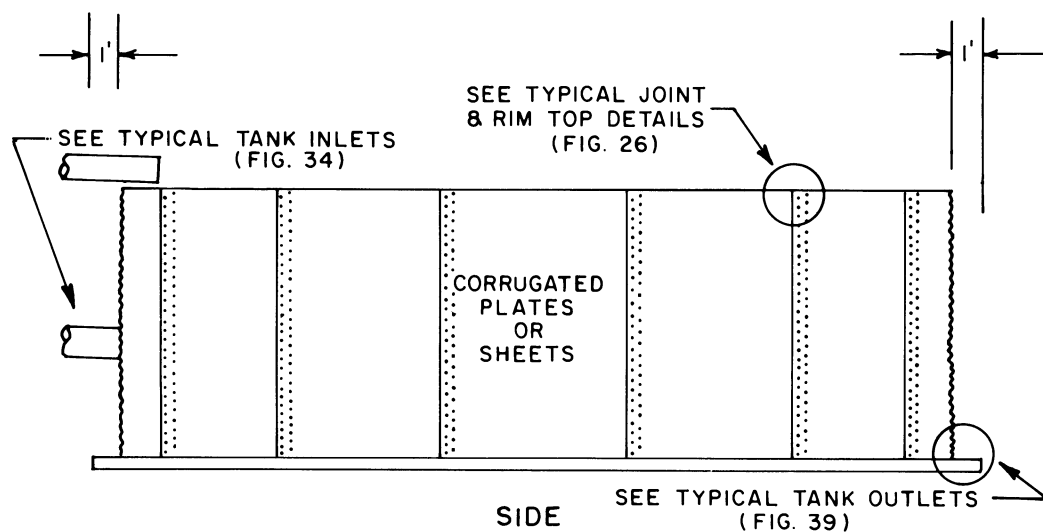

Figure 23.—Typical steel rim specifications.

drawn tight (fig. 24). Prior to backfilling, all bolts, welds, and damaged areas are coated with zinc-oxide paint or similar protective coating.

Durability. When the steel rims are properly coated with suitable paints, they are relatively resistant to deterioration and can withstand minor mechanical damage. Projected life of most steel rims is in excess of 20 years.

Estimated Costs. Costs depend on the tank size, thickness of steel, and amount of preshaping and precutting, such as bolt holes. Typical material costs of the steel rims are \$50 to \$100/1,000 gal of capacity. Bottoms or liners for the rims are an additional cost. Typical onsite assembly of the steel rim for a 30,000-gal storage will require 8 to 16 hr for a three-to-four-person crew (24 to 64 work hours). Large tanks may require mechanical means for lifting and positioning the sections.

Tank Liners

One method of sealing steel rim tanks is to place a flexible, or semiflexible, membrane liner inside the tank.

The steel rim provides the structural stability, and the liner contains the water. Most flexible tank liners are relatively easy to transport into remote sites.

Materials. Various plastic and artificial rubber sheetings have been used for tank liners. Standard black polyethylene (PE), 8 to 12 mils thick, is relatively low in cost and readily available, but it is difficult to seam. Polyvinyl chloride (PVC), 12 to 20 mils thick, is available from several plastic manufacturing companies and with the necessary expertise, it is relatively easy to seam using heat-sealing techniques. These plastic liners (PE and PVC) require a shading roof or specialized protective coating to prevent the sunlight from deteriorating the lining above the waterline. Another flexible lining material is a 20- to 45-mil-thick nylon-reinforced artificial rubber. A contact adhesive cement is used to seam the membrane into a lining. Specifications for artificial rubber and plastic membranes have been developed by the American Society of Agricultural Engineers (1).

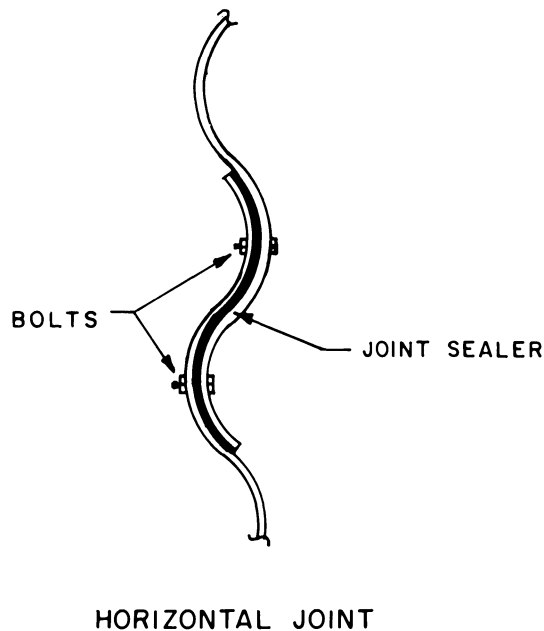
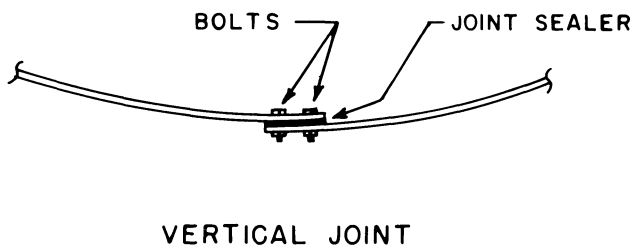

Figure 24.—Details of joint assembly for steel rim tank.

A semirigid liner, for steel rim tanks, is a three-ply membrane of an asphalted fabric-polyethylene-asphalted fabric. This lining is field assembled and consists of a single sheet of polyethylene protected on both sides by an asphalted-fabric membrane, which hardens into a semirigid membrane. The basic materials used in fabricating the lining are an asphalt clay emulsion, a polyester filter fabric, and a standard PE sheeting 6 mils thick.

Procedure. The steel rim is assembled and positioned on the prepared base. To minimize protrusions that could potentially damage the liner, all bolt heads are placed on the inside of the tank. The tank bottom is placed flush with the ground surface. On soft subgrades, the tank rim is supported on concrete leveling blocks. Two to four inches of sand or rock-free soil is placed inside the tank to provide a smooth cushion for the lining. This subbase is banked at the edges of the tank to provide a smooth transition from the tank floor to the tank wall (fig. 25) to minimize the development of excessive stress in the lining material, which would result from bridging across voids. A protective padding is placed on the top edge of the steel rim to prevent damage to the lining (fig. 26).

The simplest lining technique, with plastic and artificial rubber materials, is to place a single sheet down the side, across the bottom, and up the other side. The sheeting is draped into the tank and fastened to the upper edge of the steel rim with the excess material folded into pleats uniformly spaced around the perimeter. This technique requires excess material, which is folded along the tank sides, but does eliminate the problems of cutting and seaming a formfitting lining.

An alternate lining technique is to fabricate a formfitting liner shaped to the storage dimensions. This minimizes the quantity of material required for the lining, but requires additional labor and technical skill for fabrication. The linings are carefully extended into the corners at the bottom of the tank. The upper edges of the lining are draped over the top rim of the tank and 6 to 12 inches down the outside and banded to the tank with a steel cable (one-quarter inch in diameter) (fig. 27). Several installations have had linings destroyed by wind repositioning the linings in the tank bottom when the tanks were empty. As the tanks later filled with water, the liners were unable to reposition properly, and the weight of the water tore the lining material or pulled it loose at the top. This problem can be alleviated by placing weights in the tank bottom next to the wall.

The semirigid asphalted fabric-polyethylene-asphalted fabric lining is field assembled. Drape pretweted strips of the fabric down the insides of the tank with 6 to 8 inches of excess material at the top and bottom. Saturate each strip with asphalt emulsion, using small floor brooms or long fiber paint rollers. Overlap the strips 4 to 6 inches. Then, lay cut-to-fit fabric strips in the bottom of the tank, prewet them, and saturate them with asphalt emulsion.

Next, place a single sheet of polyethylene in the tank with 6 to 8 inches overhang on the upper rim. Fold excess plastic on the sides into pleats uniformly spaced around the perimeter. Finally, place a second layer of asphalted fabric in the tank as described in the first step.

Take care that the polyethylene sheeting is not punctured during installation of the second fabric layer. Three to five days after installation, brush a final seal coat of asphalt emulsion on the surface of the liner. A total of 1 to 1.5 gal of asphalt emulsion per square yard is required for coating the initial installation and the final seal coat.

Durability. The life of the liners is dependent upon the type of material used and the protection provided from sunlight deterioration and mechanical damage. PVC sheetings gradually harden and become brittle as the plasticizing agent migrates from the material. Projected life of a protected PVC liner is 5 to 10 years. Artificial rubber membranes (butyl) are relatively resistant to weathering deterioration and have a projected life of 15 to 20 years.

The asphalted fabric-polyethylene-asphalted fabric liner is relatively resistant to sunlight deterioration and mechanical damage. The asphaltic surface exposed

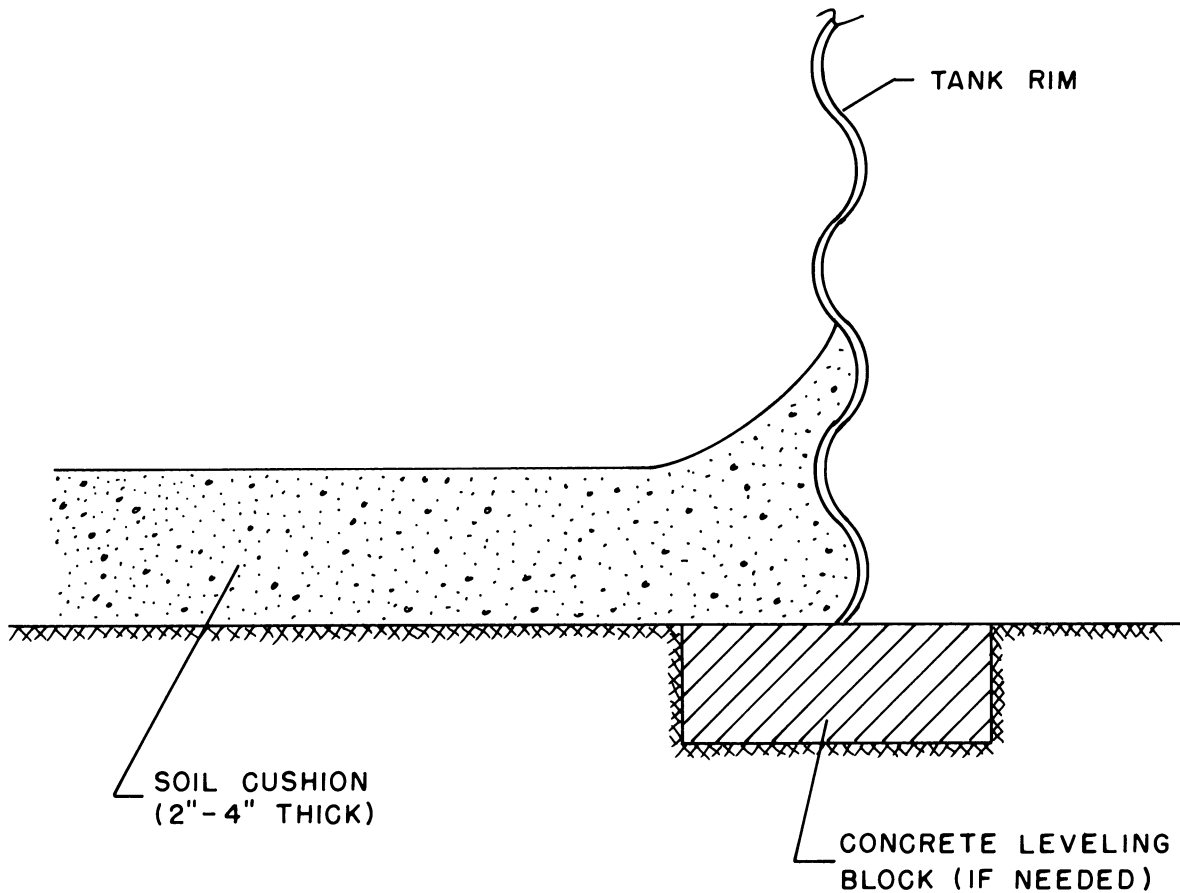

Figure 25.—Detail of tank bottom preparation for membrane liners.

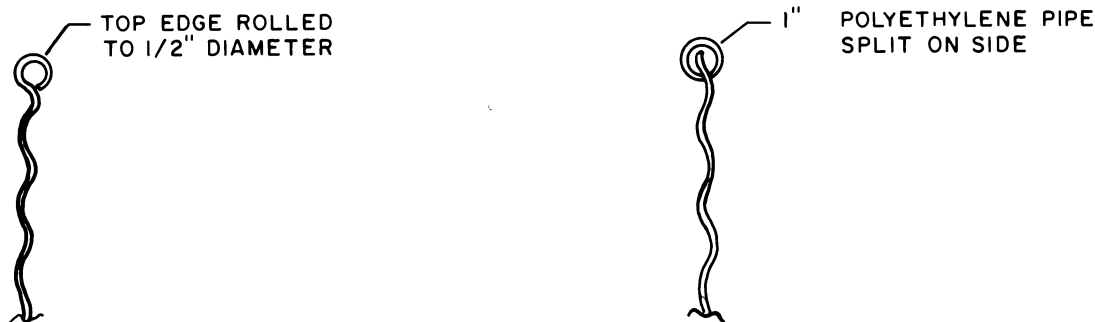

Figure 26.—Detail of tank rim alternatives to protect plastic liners.

above the waterline slowly deteriorates by oxidation, necessitating a new asphalt seal coat at a 3- to 5-year interval. The estimated life of the lining is 10 to 20 years.

Estimated Costs. Costs of the liners are dependent upon the type of material used plus the amount of prefabrication and form-fitting required. Typical lining costs are \$15 to \$30/1,000 gal of storage in addition to the cost of the steel rim. Flexible liners of plastic or artificial rubber can be installed in a 21-ft-diameter, 10-ft-high tank, in 2 to 4 hr by a three-person crew (6 to 12 work hours). The field fabricated composite membrane lining in the same size tank requires 3 to 5 hr for a three-person crew (9 to 15 work hours).

Poured Concrete Bottoms

Poured concrete floors for steel rim tanks are being used in many installations and, when properly installed, provide a durable bottom. They are relatively expensive to install in remote sites where travel distances and road conditions limit accessibility of transit mixers or large dump trucks for hauling materials. All joints in the steel rim must be sealed.

Materials. The concrete is composed of portland cement, fine aggregates, coarse aggregates, and water proportioned and mixed to produce a dense, plastic, workable mixture.



BN-49435

Figure 27.—Plastic-lined steel rim tank.

The cement should be a portland type recommended for the local aggregates and conforming to the standard specifications and tests of the American Society for Testing Materials (ASTM). The water should be clean and free from injurious amounts of oil, alkali, acid, organic matter, or other deleterious materials.

The fine aggregates should be sand or stone screenings that will pass through a standard No. 4 sieve, well graded in size from fine to coarse, and contain no more than 3 percent, by weight, of deleterious substances such as clay or silt. The coarse aggregate should be gravel or crushed stone retained on a No. 4 sieve not exceeding 1½ inches in diameter. Any joints in the bottom are sealed with a standard high-density water stop. The reinforcing wire should consist of woven wire fabric.

Procedure. Excavate a trench for the concrete stem beneath the rim of the tank on the prepared pad. Remove all loose material from the trench and compact the bottom to the density of the surrounding area. Erect the tank in the final position, but allow for it to be imbedded in the concrete 6 inches. Then place and secure the reinforcing wire. Stake a smooth, rigid form at the outside perimeter of the base.

All forms are cleaned with water or oiled, and the soil subbase is wetted to a minimum depth of 1 inch. The concrete is placed in a continuous pour, without seams or planes of weakness within a section, and is consolidated by agitation or vibration to insure proper bonding with all reinforcing. Care is taken to insure that all water-stop barriers and the rim of the tank are properly placed and firmly imbedded in dense concrete (fig. 28).

The concrete is struck off by straight edge screeding and hand finished to a smooth, even surface by wooden floats or other suitable means. Concrete should not be placed during inclement weather. Immediately after finishing, a concrete curing compound is applied, as recommended by the manufacturer.

Durability. Properly installed concrete bases are very durable with a projected life in excess of 20 years. Cracks in the concrete have been a problem in some installations. Tanks with diameters greater than 20 ft should have expansion joints with water stops. Back-filling around the base of the tank reduces the cracking caused by unequal thermal expansion of the steel tank and concrete base.

Estimated Costs. Costs of concrete bases are highly variable depending upon site accessibility. Typical onsite costs for the tank bottoms are \$5 to \$20/yd² of base (\$200 to \$800 for a 21-ft-diameter tank) in addition to the cost of the steel rim. Typical labor requirements are 4 to 8 hr for a four- to five-person crew (16 to 40 work hours).

Plastered Concrete Tanks

The plastered concrete storage tank consists of a thin (3 to 4 inches thick) vertical circular wall of reinforced concrete with a dense plaster coating on the inside and outside surfaces (36, 45). The bottom of the tank is of poured concrete. Maximum tank dimensions are 6 ft high and 30 ft in diameter (30,000 gal). These storages have been used in semiburied as well as aboveground installations.

Materials

The concrete is composed of portland cement, aggregate, and water proportioned and mixed to produce a dense, plastic, workable mixture suitable for troweling into a vertical wall of steel reinforcing fabric. The concrete is proportioned of one part cement to three parts aggregate with a maximum of 5 gal of water per 96-lb sack of cement. The workability of the mix can be improved by adding one part masonry cement to five parts portland cement, which is recommended for the local aggregates and conforms to the standard ASTM specifications and tests.

The aggregates should be of hard, clean, durable particles, maximum diameter ¼ to ⅜ inch, and well graded in size from fine to coarse, containing less than 3 percent, by weight, of deleterious substances such as clay and silt. Aggregate for the floor may have a maximum diameter of from ¾ to 1 inch. Plaster is the same formulation as concrete used in the walls, except that aggregate is limited to sand. The tank wall reinforcement consists of standard 7-ft concrete reinforcing woven wire and a fine mesh (maximum opening, 1 inch) woven wire (rabbit wire).

Procedure

Mark the location of the tank walls on the surface of the prepared pad by inscribing a circle of the required tank diameter. Cut two pieces of reinforcing wire, each with a length equal to the circumference of the tank plus 6 to 12 inches for overlap, to form the reinforcing hoops. Fold down the top edge of the wire for the outside hoop 12 inches, and fold up the bottom edge of the wire for the inside hoop 15 inches. Set the outside wire hoop on end (folded edge up) on the inscribed circle and wire the ends together. Set the inside hoop in place (folded edge down) with a space of ½ to ¾ inch between the inside and outside hoops with the

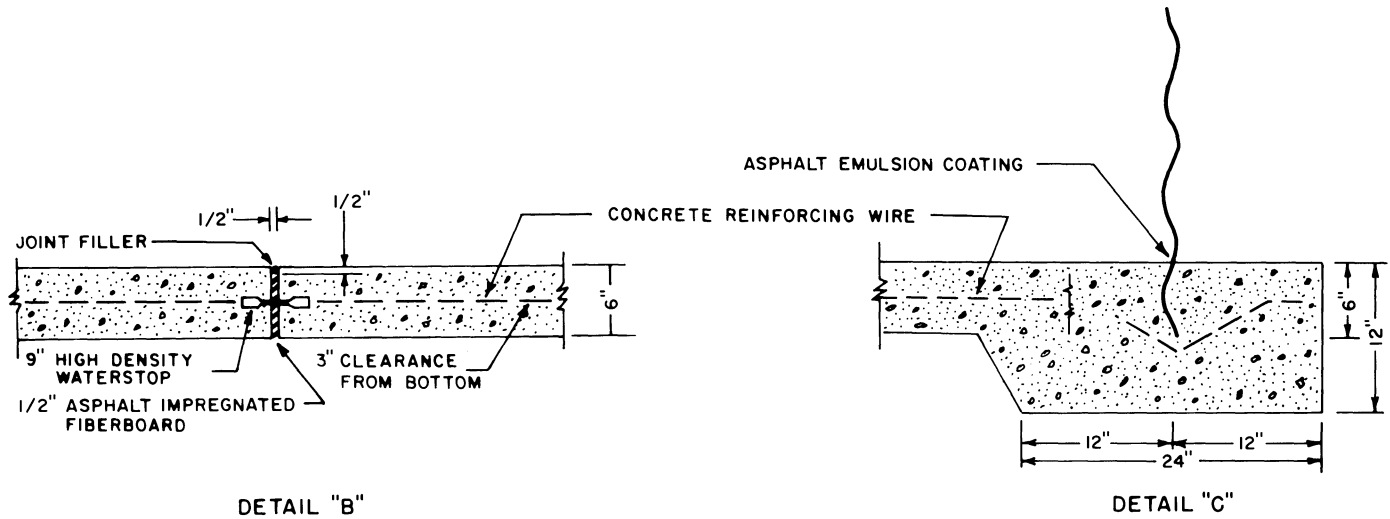
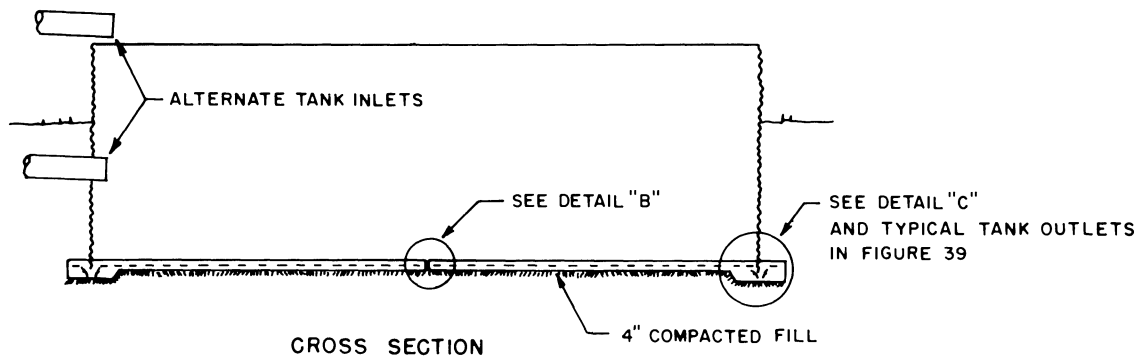

Figure 28.—Detail of concrete base for a steel rim tank.

splices of the hoops offset a minimum of 12 inches. Fasten rabbit wire containment mesh to both the inside and outside of the reinforcing walls. Stake U-shaped pieces of $\frac{3}{8}$ -inch reinforcing bar (8 to 12 inches long) to keep the bottom of the reinforcing wire cage in place. Fasten a temporary backup wall of thin metal sheeting (4 by 8 ft, 16 gage) to the outside of the wire cage. From inside the tank, work the plaster-concrete mix into and through the reinforcing wire cage using steel or wooden trowels, completely filling the space between the two layers of rabbit wire. Take care to insure there is a dense mix penetrating through the reinforcing wire to the backup sheets on the outside. Immediately after the initial set, cover the concrete with moist burlap sheeting for curing. As each section of the wall is finished, drape a plastic sheet over the sides to reduce the rate of water evaporating from the curing concrete.

After the core wall is finished and the concrete has started to set, trowel a plaster coating of the same concrete mix, approximately one-half inch thick, on the inside and outside of the tank. If the core wall has dried, remoisten the concrete before applying the plaster coat.

Place reinforcing wire mesh on the bottom of the tank and imbed it in a 4-inch-thick poured concrete floor.

Build up the inside and outside base of the wall to insure a positive watertight seal (fig. 29). After the plaster has cured for 1 to 2 weeks, wire brush the inside wall and the floor of the tank to remove loose material and brush two coats of emulsified asphalt paint on the surface.

Durability

Properly installed plastered-concrete tanks are very durable with a projected life in excess of 20 years. In some cases, the asphalt paint did not bond to the plaster, probably a result of the loose material on the tank surface. The concrete can crack if it is allowed to dry too fast during the curing process.

Cost

Typical onsite costs for a plastered-concrete tank are \$25 to \$50/1,000 gal. Materials costs will be significantly reduced if locally available sand and gravel are used. A typical 20-ft-diameter tank would require 5 days for a four-person crew (160 work hours).

Membrane-Lined Reservoirs

Excavated earthen reservoirs have been used only in a few water-harvesting installations. Because of the diffi-

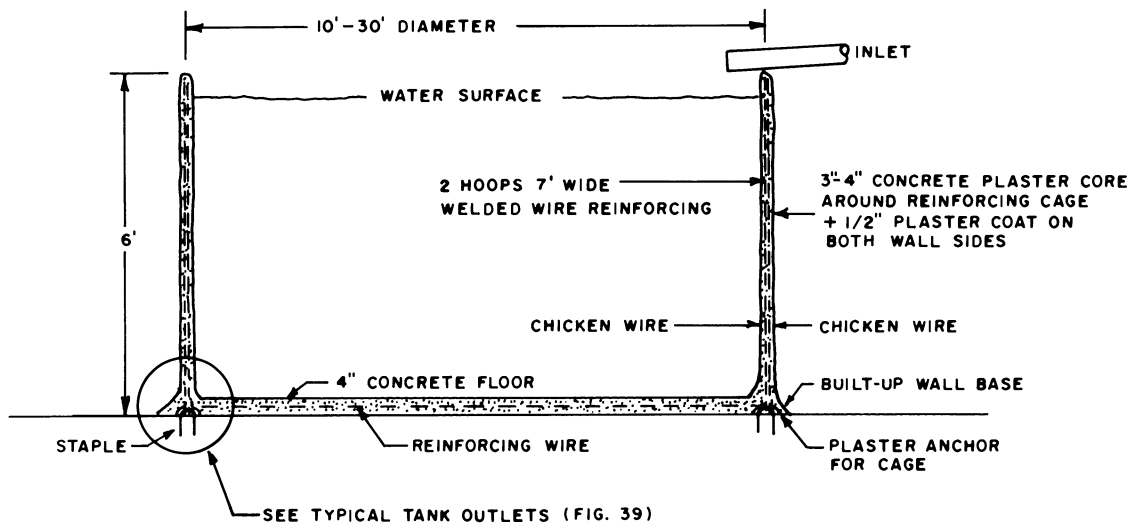

Figure 29.—Cross-section of plastered concrete tank (45).

culty in effective control of evaporation from storages with sloping side, these reservoirs are inefficient in areas where the annual evaporation significantly exceeds the annual precipitation. In Australia, unlined earthen reservoirs (batter dams) have been used in conjunction with large "roaded catchments" (2). In much of the United States, high seepage losses from unlined earthen reservoirs, combined with high evaporation rates, have restricted their use on water-harvesting systems.

Various types of chemicals and soil sealants, such as waterborne asphalt emulsions, bentonite clays, and long-chain polymers, have been considered as potential methods for sealing unlined earthen reservoirs. Most of these materials have a relatively narrow range of soil properties (physical and chemical) where the treatment may be effective, and many are destroyed whenever the treated soil dries. Most of these materials have not proved satisfactory for use in water-harvesting systems.

One chemical sealant method, potentially suitable for sealing some unlined reservoirs, is a clay dispersion technique using sodium salts. Aggregated soils, containing more than 15 percent montmorillonite clays ($>2\mu$) with a predominance of calcium, can often be sealed by the application of a sodium salt (NaCl , Na_2CO_3), which will disperse the clay and break down the soil aggregates (39).

In some special circumstances, unlined, sodium-sealed earthen reservoirs, in combination with oversized catchments, may provide a satisfactory water-harvesting system. Even with a good sodium treatment, the seepage rate can be equal to the evaporation rate (~ 0.25 inch/day), which prevents the extended storage of water.

Most excavated earthen reservoirs presently used on water-harvesting systems are lined with some type of waterproof membrane. The linings can be separated into two general types: (1) exposed linings and (2) buried linings. Materials susceptible to weathering or mechanical damage must be protected by a covering of soil or gravel (buried linings). Field experience has shown that all plastic film membrane must be buried. Artificial rubber

membranes need not be covered unless mechanical damage by livestock, vandals, or wind is expected.

Materials

Various types of PVC and PE plastic sheetings, 12 to 20 mils thick, have been used for linings. These materials will deteriorate when exposed to sunlight and are susceptible to mechanical damage, particularly by wind, which necessitates that these materials be limited to buried membrane installations. The plastic sheetings are available from several manufacturing companies.

Nylon-reinforced artificial rubber sheetings, such as butyl, 20 to 45 mils thick, have been used for numerous lining projects. These reinforced sheetings have sufficient resistance to mechanical damage and weathering deterioration, when properly fabricated and installed, to permit use as exposed linings.

A semirigid liner for exposed installations is a field assembled, three-ply membrane of an asphalted fabric-polyethylene-asphalted fabric. This is the same material previously described for lining steel rim tanks (p. 22).

Procedure

The ASAE (1) has provided detailed instructions for installing exposed and buried linings of flexible membranes. These standards should be adhered to within the limits imposed by site characteristics. The following discussion is a brief summary of these standards.

For *buried membranes*, the earthen pit must be over-excavated 6 to 9 inches in all dimensions to allow for the soil cover. Side slopes should not be steeper than 3-horizontal to 1-vertical. The final subgrade must be firm enough to support workers or equipment during the lining installation. All large soil clods, roots, rocks, or foreign material that might puncture the lining must be removed and depressions and soft spots filled. Rolling or compaction of the subgrade is desirable.

Excavate a trench 10 inches wide and 6 inches deep, 6 inches back from the pit edge, around the perimeter of

storage (fig. 30). The front edge of the trench is rounded and cleaned of all loose material that could cause stretching or tears in the lining material.

Carefully position the plastic-lining material in the prepared excavation in a relaxed state with a minimum of 10 percent slack evenly distributed in both directions. Fold excess lining material at the corners into uniform pleats laid flat on the surface. Position the upper edges of the lining across the bottom of the anchor trench and up the backside.



BN-49436

Figure 30.—Burial trench for reservoir membrane lining.

During placement of the sheeting, insure that the material is not subjected to undue tensile stresses that can cause holes or create weak spots in the material. Do not install buried membranes when the temperature is below 32° F. Special precautions are necessary when placing the soil cover when air temperatures exceed 100°, because the puncture resistance of many plastics decreases as the temperature increases.

The soil used to cover buried linings should be sufficiently stable to resist wind erosion and water scouring at or above the waterline and must resist sliding down-slope. The soil material immediately in contact with the lining, both under it and over it, should be coarser than a silty sand.

To place the cover material, begin at the bottom of the pit and proceed toward the top. Place the soil cover, a minimum thickness of 6 inches (3 inches of fine material next to the lining), so that the lining is not displaced or damaged by equipment or overburden. Finally, backfill the anchor trench.

On large storages, install one sheet at a time to prevent damage from wind or mechanical means. Starting at the lowest point, position the first plastic sheet with a 4-inch minimum overlap and seam it in accordance with the manufacturer's recommended techniques and seaming materials. Then, cover this sheeting and repeat the procedure until the lining is completed.

Exposed rubber linings may be installed on slopes up to 2-horizontal to 1-vertical. Exposed linings have been damaged by movement of the sheeting against the soil surface caused by unequal air pressures from wind passing across the top of the excavation. Under some conditions, negative air pressures can develop with sufficient force to lift the sheeting off the soil surface. The sheeting movement can sometimes be reduced by minimizing the angle of the outside slope of the banks and the side slope into the reservoir in the direction of the wind and by orienting the excavation so that the wind approaches from the direction of a corner (11).

Carefully position the lining material in the prepared excavation in a relaxed state with a minimum of 5 percent slack allowance in both directions. Fold the excess material at the corners into uniform pleats, and lay it flat on the surface. Place the upper edges of the material across the bottom of the anchor trench and up the backside, and backfill the trench with clean soil, using care to prevent stressing the lining material.

On large storages, the linings are often installed in sections with field-made seams joining the separate sheets. Position the first sheet and backfill the anchor trench. Lay the next sheet in place with a 4-inch minimum overlap, and seam it in accordance with the manufacturer's recommended techniques and seaming materials. All seams should be oriented up and down the slope to reduce stresses on the joint. Continue this procedure until the lining is completed.

The *composite lining* is a three-ply layer of asphalted fabric-polyethylene-asphalted fabric, which is fabricated in place in the field. Lay the polyester filter fabric on the prepared surface with at least 1 percent slack in each direction to allow for shrinkage. Lay the edges of the material across the bottom of the anchor trench and up the back side, prewet the fabric with a weak soap solution, then saturate it with the asphalt emulsion. Spread the asphalt uniformly over the fabric by brushing with soft bristle floor brooms. Apply the clay-asphalt emulsions, usually requiring dilution with water before application (2 gal/55-gal drum), at a rate of approximately $\frac{1}{2}$ gal/yd².

Next, place a single sheet of polyethylene on the surface with an evenly distributed 10 percent slack. Make sure that the plastic sheeting is not punctured or inadvertently damaged and that the slack is evenly distributed. The edges of the plastic sheeting are placed into and across the burial trenches, using care not to puncture the membrane.

A top layer of polyester-filter fabric is laid in place, pre-wetted, and saturated with asphalt emulsion at a rate of $\frac{1}{2}$ gal/yd². Take care not to damage the polyethylene during placement and coating of the top fabric layer. After the lining has been coated with asphalt, the anchor trenches are backfilled and compacted with clean fill material. Apply a final topcoat of asphalt emulsion at a rate of $\frac{1}{4}$ gal/yd² to the portion of the lining above the waterline.

On large reservoirs, install the lining in sections. Cover an area slightly larger than the plastic sheeting with the filter fabric and coat it with asphalt (fig. 31). Lay the plastic sheet in place. Then, lay the second fabric layer in place and coat it with asphalt. A 2-ft strip at the edge of the plastic should be left uncovered to permit seaming of the next section. Seam plastic with a contact adhesive tape. Continue this procedure until the lining is completed.



BN-49437

Figure 31.—Installation of asphalt-fabric, polyethylene lining in excavated reservoir.

Durability

The life of the liners is dependent upon the type of material used and the protection provided from mechanical damage and sunlight deterioration. Buried plastic liners have a projected life of 10 to 20 years. Exposed linings of artificial rubber (butyl) not subjected to tensile stresses and properly installed have a projected life of 15 to 20 years. The asphalted fabric-polyethylene-asphalted fabric composite lining has a projected life of 15 to 20 years. A periodic application (5-year intervals) of an asphalt seal coat is required on the lining exposed above the waterline.

Estimated Costs

The unit area costs for buried linings are highly dependent upon availability of materials for use in the soil cover. Typical materials costs for the plastic lining are \$0.20 to \$0.50/yd². Labor requirements are dependent upon type of equipment available for placing the soil cover. A typical storage of 40 by 50 ft and 6 ft deep would require a crew of five workers 2 to 3 days.

The materials cost of artificial rubber linings for exposed installations is \$7 to \$10/yd². Installation on a 40- by 50- by 6-ft pit would require four to five workers a total of 6 to 8 hr.

The materials cost of the composite linings is \$3 to \$5/yd², and installation requires five workers a total of 10 to 14 hr.

Section 7.—Construction Methods and Materials—Miscellaneous

Evaporation Reduction

General

Conserving the water collected from a water-harvesting system is a cost-effective method of maintaining an adequate water supply. Reducing evaporation is usually less expensive than increasing the size of the reservoir and/or catchment to offset the evaporative loss. On a typical system in northern Arizona, the cost of the evaporative reduction was less than 4 percent of the total cost of the entire water-harvesting system (6).

The greatest research effort in controlling evaporation has been with monomolecular films of long-chain alcohols (cetyl alcohol). Despite promising laboratory studies, field investigations showed effective reductions of less than 25 percent, and the films are almost impossible to maintain in the presence of wind (24). Steel tanks with integral tops are effective in controlling evaporative losses but are expensive. At present, the most effective methods of evaporation control are covering or shading the water surface with floating covers or roof-type shades. These techniques are relatively successful on vertical wall tanks, which have a constant size exposed surface area. It is significantly more difficult and expensive to effectively control evaporation on reservoirs with sloping sides where the water surface area changes with depth.

Roofs

Roofs of sheet metal on a wooden or steel framework have been used in many places to control evaporation. The roof shades the water from direct sunlight and reduces the wind velocity directly above the water surface. They are often oversized and placed in an inverted position above the storage tank to provide additional catchment area (fig. 32).

Studies on ponds showed that shading and wind velocity reduction reduced evaporation by 35 percent (7). This



BN-49438

Figure 32.—Inverted roof cover over steel rim storage tanks.

figure can be substantially improved by minimizing the space between the roof and the top of the tank. Exposed roofs are potentially susceptible to damage by wind and, in some areas, by snow loads.

The cost of constructing a roof is highly variable, with typical costs estimated at \$10 to \$20/yd², depending upon materials used. The costs of roofs should not always be assigned to evaporation control. In some areas, the roof can be oversized with little additional cost, allowing for a corresponding reduction in the size of the main catchment area. They can provide a compact, complete, effective water-harvesting system (40). Properly installed roofs have a projected life in excess of 20 years.

Floating Covers

For vertical wall tanks, evaporation losses can be effectively reduced with floating covers placed directly on the water surface. Floating cover materials, such as polystyrene sheeting, plastic balls, low-density perlite ore, and a continuous layer of paraffin wax, have been investigated (5). At present, most of these materials have not been satisfactory for use on operational water-harvesting systems. Foamed, artificial rubber sheeting is one material being used successfully, and is relatively easy to construct and install (12).

Materials. The foam rubber cover is made from a low-density, closed-cell ethylene-propylene-diene-monomer (EPDM) synthetic foam rubber sheeting ¼-inch thick. The foam rubber comes in various roll widths up to 4 ft wide. The sheets are seamed together into a single piece cover with a contact adhesive.

Procedure. Foam rubber covers will gradually shrink with time (3 to 5 percent in 6 months) and, to insure maximum effectiveness, should be correspondingly oversized. Assemble the cover on a hard, flat surface. Sketch a chalk outline of the required cover size on the work surface and carefully position strips of the foam rubber in a parallel alignment with a 2- to 3-inch overlap. Fold back the overlap of the top sheet and clean the exposed joint area of any dust or antisticking dusting compounds applied during manufacture, which may interfere with the adhesive bond. Clean the surface with xylene, naphtha, toluene, or methyl ethyl ketone solvents. Personnel using these solvents must wear rubber gloves to avoid skin contact and must work in a well-ventilated area to avoid breathing fumes.

Brush the cement adhesive onto the cleaned surfaces, allow them to dry to a tacky consistency, then carefully place the turned back edge onto the lower sheet without stretching or changing the alignment of the two strips. Press flat the joined surfaces. After seaming, mark the desired shape of the cover on the surface with chalk and trim off the excess material. Bond a strip of foam rubber (½ by 1 inch) along the underside of the cover circumference, as close as possible to the edge to assure the cover edge is in positive contact with the water surface.

Cut bail holes one-half inch in diameter into the cover on a 4-ft spacing to allow water trapped on the surface to drain off. Place the cover on the water surface with the stripped edge surface down. Stretch wires across the tank top to keep the cover down during windy periods when the water level is near the top.

Durability. The foam rubber (EPDM) is relatively resistant to weathering deterioration and has a projected life of 5 to 10 years. The foam sheeting, which can be damaged by mechanical means, must be carefully handled during construction and installation. Damaged areas can be easily repaired with small patches glued to the surface. Even with restraining wires, wind passing over the edge of a tank partly full of water may disrupt the cover. With extremely windy locations, a roof structure would be a more preferable method of evaporation control.

Estimated Costs. The foam rubber sheeting costs \$0.50 to \$0.90/ft². Experience has shown that two workers can assemble a 30-ft diameter cover in 2 to 3 hr (4 to 6 work hours).

Catchment and Storage Conveyance

Some water-harvesting systems utilize membrane-lined pit storages built at the lower edge of the catchment (fig. 33). On most systems, the storage tank is located some distance from the catchment apron, and a large pipe or lined channel, which may include provisions for trapping sediment and trash, carries the water from the catchment to the storage.

The conveyance must be of sufficient size to carry the water collected during high intensity storms from the catchment without ponding on the catchment surface. While many different designs and materials have been used, most conveyance systems utilize a rectangular or half-circle open channel or a large-diameter pipe (usually steel culverts or well casings). Some installations have been constructed with large-diameter, heavy-wall, rigid



BN-49439

Figure 33.—Butyl-lined storage directly connected to catchment apron.

plastic pipe. Experience has shown that, for catchments of one-quarter acre, the conveyance should have a minimum cross-sectional area of 0.6 to 0.8 ft² (10- to 12-inch-diameter pipe); larger catchment areas require a correspondingly larger size. The type and shape of the conveyance channel is often determined by the local availability of materials.

Starting 1 to 2 inches below the lowest point of the catchment apron, the conveyance channel is usually placed on a minimum slope of 0.5 percent and discharges into the top of the storage tank. Most plastic pipes require protection from exposure to direct sunlight and provisions to allow for longitudinal thermal expansion of the pipe. Spans greater than 20 ft between catchment and storage require some type of support system with sufficient strength to bear the weight of the conveyance *plus* water to prevent sagging of the channel or pipe. Steel or wooden frameworks are often used for the supports. On some soils, support pads of reinforced concrete may be necessary to prevent settlement from soil compaction with time. The framework and conveyance channel should be anchored to the ground to prevent potential wind damage.

The distance between the catchment and the water tank is dependent upon the type of tank selected (vertical height) and general slope or topography of the land. With gentle land slopes (<10 percent), the distance between catchment and storage may be relatively long to provide the necessary height to clear the top of an aboveground tank. Because wooden or steel supports for long distances are expensive, earthen embankments 6 to 8 ft high, formed by pushing with a bulldozer, may be used in some locations. The fill material should be firmly compacted and side slopes less than 2-horizontal to 1-vertical. A borrow area, 15 to 20 ft wide by 6 to 12 inches deep on each side will provide sufficient soil for the embankment. All disturbed areas should be seeded to adaptable plant species to prevent undesirable weed growth and soil erosion.

The distance between catchment and reservoir can be reduced by partially burying the storage tank to reduce the elevation difference or using low-profile storages. Another option is to lay the pipe from the catchment to the storage tank at ground level or buried in a shallow trench. The pipe is connected through the side or bottom of the tank (fig. 34). This technique can be less costly than long-distance support structures, but special considerations are necessary to insure the water-holding integrity of the storage. A small leak in the pipe connections can mean loss of the stored water.

Sediment Traps

Sediment traps are not required on all water-harvesting systems. The major sediment problem is usually from bedload material that will quickly settle out of the water. Suspended colloidal clays are usually of minor concern unless the water is being used for domestic purposes. Sediment traps should not be installed unless a potential sedimentation problem may interfere with the perfor-

mance of the system. Membrane catchment treatments do not usually generate sufficient sediment to warrant sediment traps. Traps should be considered for systems where the catchment is treated with paraffin waxes or other chemical soil treatment and where the water is stored in enclosed containers, that is, horizontal cylindrical steel tanks and butyl bags, which cannot be easily cleaned. Water-harvesting systems with membrane-lined reservoirs, which may be susceptible to damage in cleaning operations, may require sediment traps. Steel rim tanks with concrete bottoms can usually be cleaned and would not require sediment traps.

There are many types of suitable sediment traps. They should be easy to clean and have provisions for automatic bypassing of the water should the trap become filled. Figure 35 shows the general shape and dimensions of a sediment trap being used on operational water-harvesting systems with catchment aprons up to three-quarters of an acre in size. The trap is located at the lowest part of the catchment and discharges directly into the conveyance pipe to the storage tank. With a small ramp included, the trap also serves as a small wildlife and bird water supply, which reduces the possibility of the animals becoming trapped trying to obtain water from the storage tank.

All sediment traps should be inspected and cleaned at periodic intervals during the year. Additional inspections should be made any time it is suspected that there has been a high-intensity storm in the area.

Screens

Some water-harvesting systems will require screens to prevent animals and trash from getting into the storage tank through the conveyance system. The screens must be properly designed, placed, and maintained to prevent clogging that can interfere with the flow of water from the catchment surface. Figures 36 and 37 are sketches of various screen configurations being used on operational water-harvesting systems. The screen should have a minimum mesh size of 3 inches. The screening area should be at least 10 times larger than the cross-sectional area of the conveyance channel. The screens should be sloped upward in the direction of the flow to allow the water to flow up and over any clogging that occurs in the lower portion of the screen. Periodic maintenance for cleaning the screens is extremely important. Screen clogging problems can be reduced by eliminating or controlling unwanted weeds, such as Russian thistle, immediately around the catchment.

Fences

Fencing of the water-harvesting facility is an added cost and may not be required on all systems. Several asphalt-fabric membrane-covered catchments, left unfenced, were not damaged during a 10-year period of observation. Animals normally would not damage catchments of concrete or sheet metal. Wax soil treatments, butyl sheeting, and gravel-covered sheeting must be fenced to prevent animals from walking on the surface. Fencing

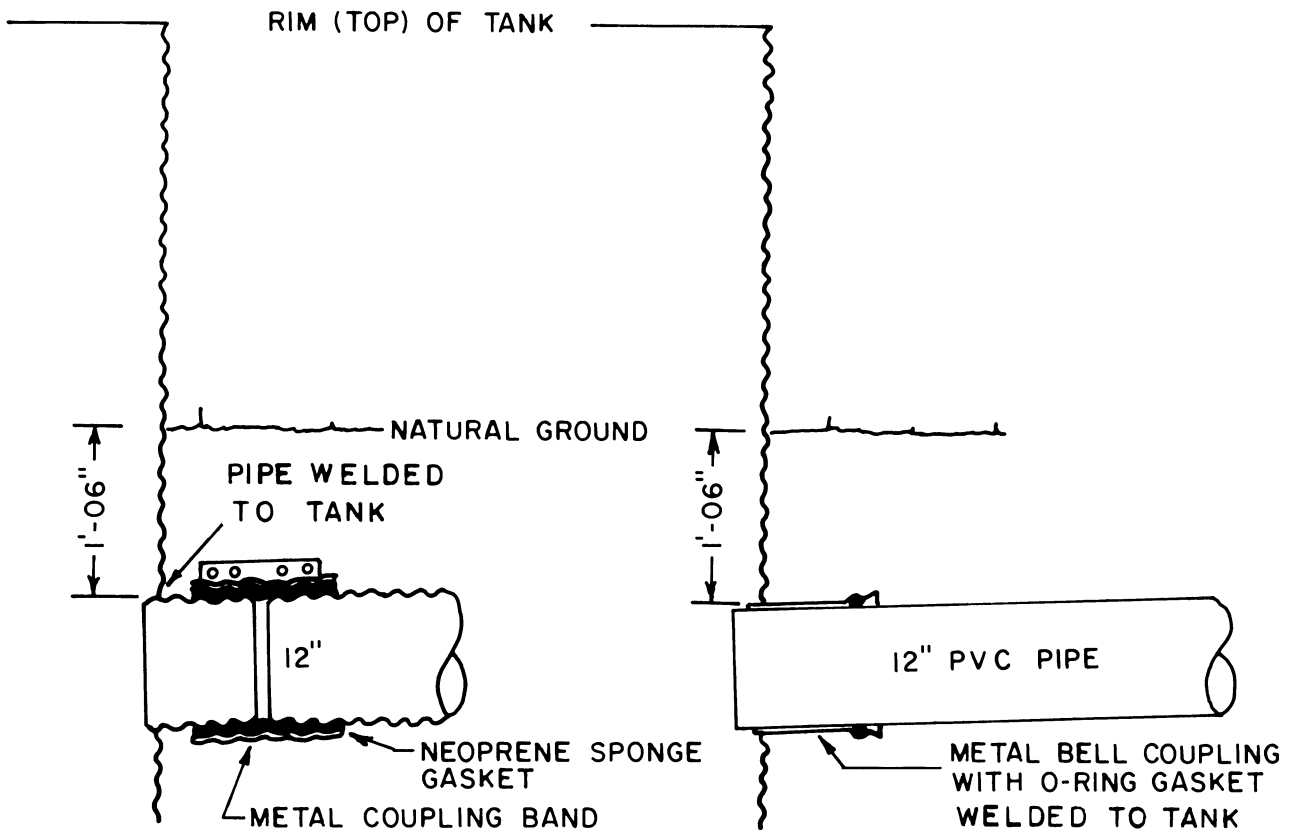

Figure 34.—Details of connecting buried conveyance pipe into side of storage tank. Finished pipeline from catchment to storage tank must be water tight.

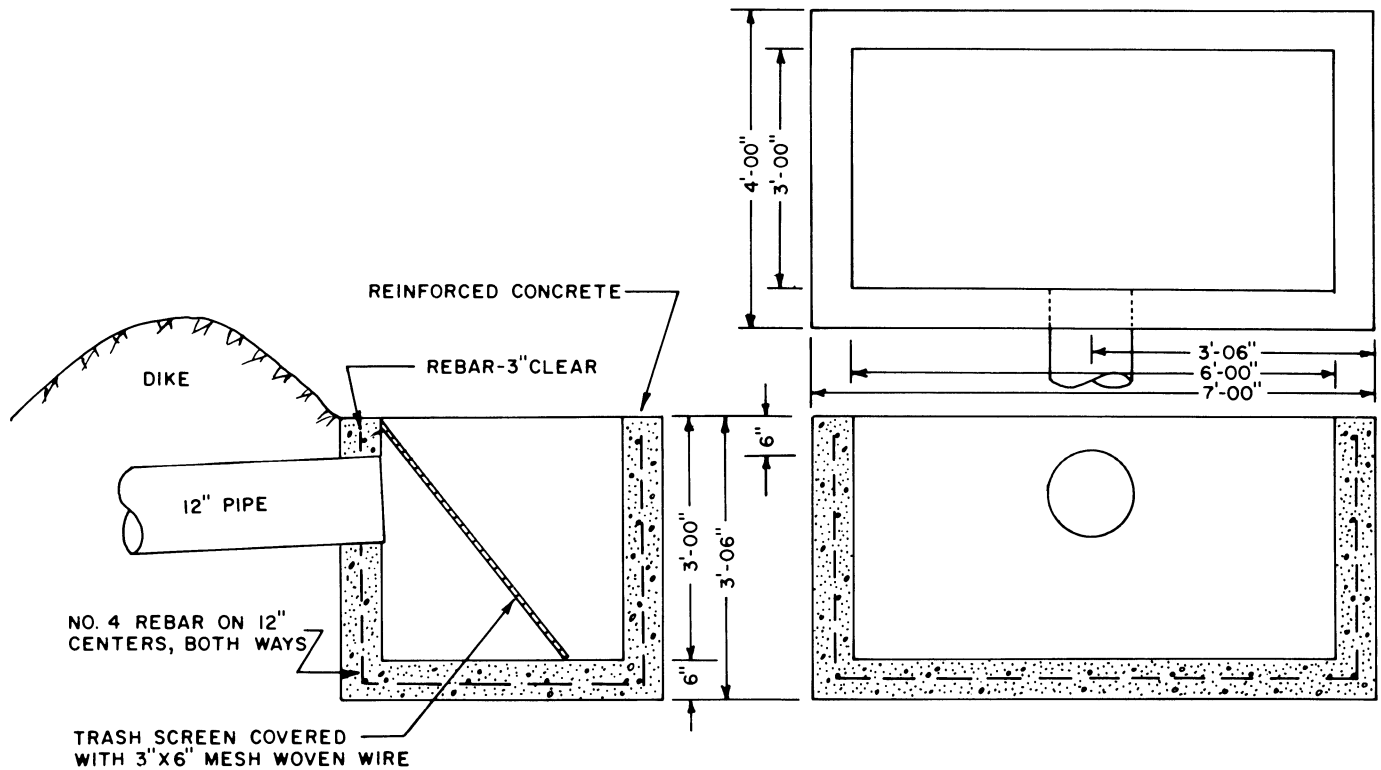
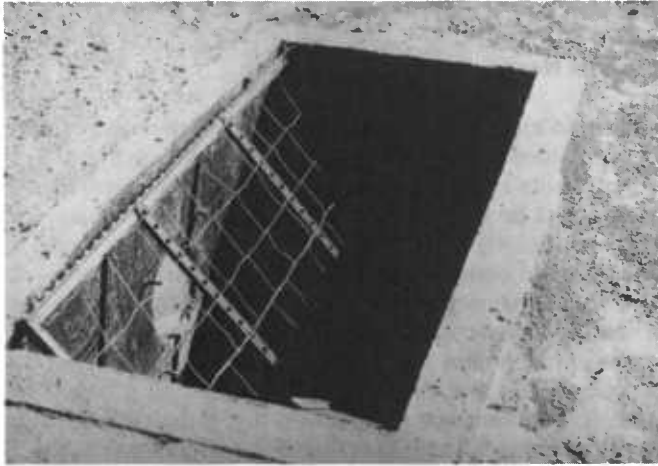

Figure 35.—Detail of sediment trap.



BN-49440

Figure 36.—Trash screen used with sediment trap.

costs can be minimized by placing the fence immediately adjacent to the catchment apron. Storage tanks greater than 6 ft above the ground surface do not require fencing. Usually, a tight four-wire barbed fence with proper post and stay spacing is adequate. In some installations, a high (10-ft) woven wire fence may be needed to prevent large game animals from getting inside the enclosure.

Diversion Ditches

Excess surface runoff water from upslope of the catchment apron should be diverted around the area by dikes and/or diversion ditches. This runoff water is usually

heavily loaded with sediment and trash, and if allowed to run onto the catchment surface, can clog screens and sediment traps. Upslope water running next to the catchment surface can wash out anchor trenches, exposing the edges of membrane treatments to potential wind damage. Chemical soil treatments can be severely eroded by excess water running over the surface. Water seeping under the catchment treatment can cause premature failure and will promote the growth of plants from buried seeds or roots.

The dikes around the catchment apron should not be used to divert the upslope runoff water. This water is best controlled by constructing separate dikes, diversion channels, or ditches a minimum of 20 feet upslope from the catchment apron.

Piping, Valves, and Drinking Troughs

All piping and valves should be of high-quality materials, galvanized steel or approved plastics, and installed according to the manufacturer's specifications. Valves should be of corrosion-resistant materials of sturdy construction. Various types of drinking troughs are available (fig. 38).

Figure 39 shows some of the methods used to connect outlet pipes to the storage facility. Float valves must be properly installed with protection against freezing and animal or vandal damage. This is usually best accomplished by installing buried float boxes. Figure 40 shows a suggested float arrangement.

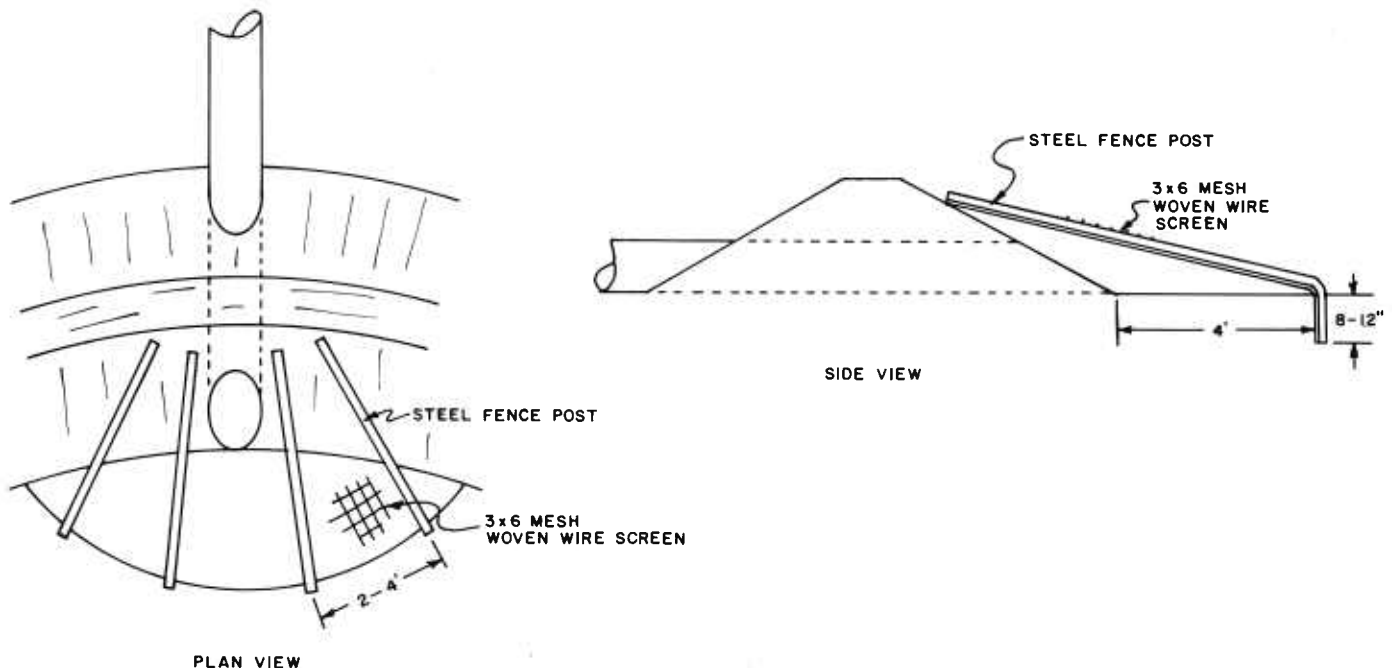

Figure 37.—Trash screen at inlet to conveyance pipe at lower edge of catchment area.



BN-49441

Figure 38.—Typical animal drinking trough with pole fence to protect water-level valve.

Section 8.—Maintenance

General Need

Failure to maintain a water-harvesting system will result in premature failure of the system. The effective life of components and materials used in a water-harvesting system will be significantly extended by proper maintenance (fig. 41), whereas failure to repair minor damage can result in complete destruction of the system (figs. 42 and 43). A maintenance program must be followed, even when the water collected is not being utilized. Some types of catchment and storage tanks require more frequent and intense maintenance than others. The specific maintenance program utilized must be matched to the specific system. Most water-harvesting systems can be adequately maintained with twice-a-year inspection and repair visits plus the immediate repair of any problems detected at other times. All elements of the system should be inspected, including checks for leaks in valves, pipes, and storage tanks, as well as the condition of the catchment, fence, and weed, rodent, and insect control. These scheduled inspection and repair trips usually require less than four hours of labor per visit, and can be very cost effective.

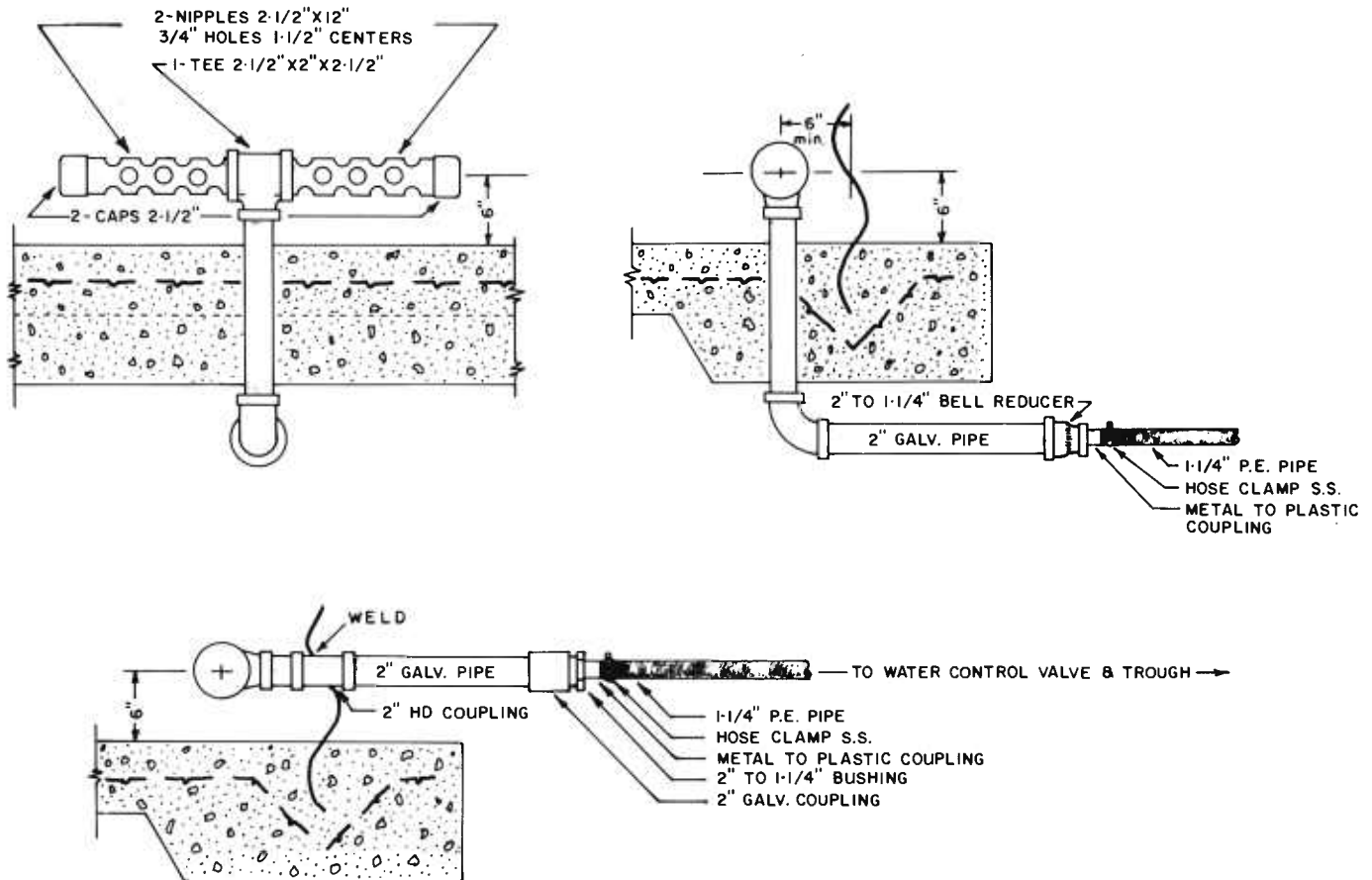

Figure 39.—Two methods of connecting drinking trough supply lines to storage tank. Above: Supply line trough bottom of tank. Below: Supply line through wall of tank.

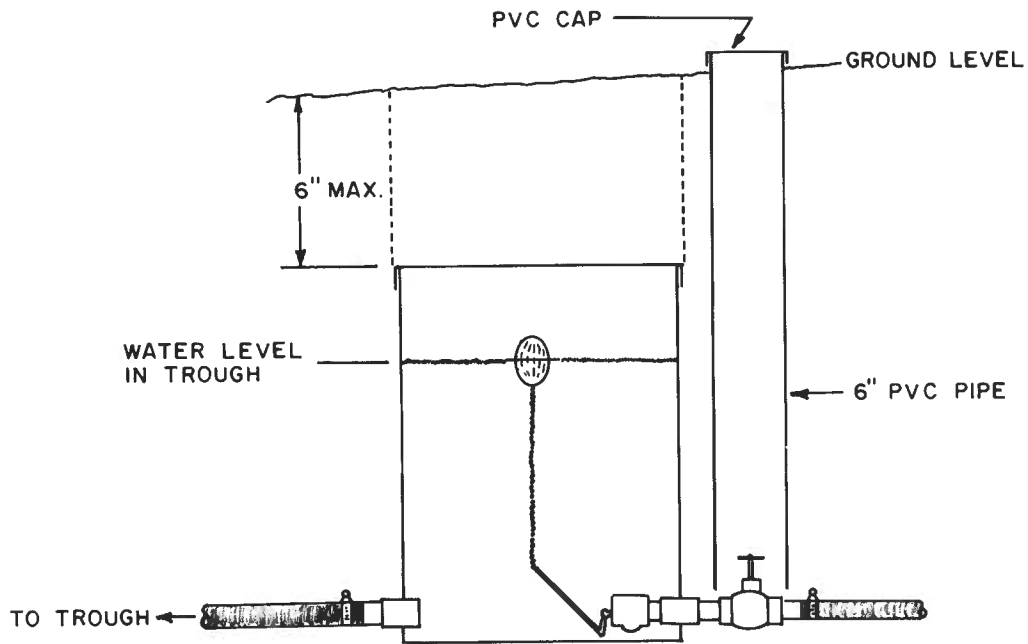

Figure 40.—Typical buried valve and float arrangement.



BN-49442

Figure 41.—Removal of plants growing through asphaltic catchment treatment.



BN-49443

Figure 42.—Asphalt-planking catchment treatment in need of preventive maintenance.



BN-49444

Figure 43.—Catchment treatment destroyed by wind because of the lack of preventive maintenance.

A storage-type rain gage should be installed at each site to obtain an estimate of the quantity of precipitation that occurs. By knowing the precipitation, you can estimate the quantity of water that will be produced from the catchment. Furthermore, by comparing the amount of precipitation to the quantity of water actually stored, you can estimate the catchment runoff efficiency or determine if there is a leak or seepage loss from the storage. Although a rain gage is desired, any cylindrical can with vertical walls, such as a half-gallon tomato or orange juice can, will provide reasonable measurements. The gage or can should be securely anchored in an exposed location 2 or 3 ft above the ground to help avoid damage by curious animals. A shallow layer (one-eighth inch) of low viscosity oil placed in the rain gage prevents evaporation of the collected water.

Specific Requirements

Damage to the catchment surface by rodents and insects is one of the most aggravating maintenance problems. On membrane treatments, these pests can eat holes in the material, which allow wind access under the covering unless they are patched. The severity of this problem will vary with the type of materials used and the location of the system. Initial vibration or movement of the cover by the wind is usually minor, but it increases with time, and will ultimately destroy the membrane. Rodent and insect damage can be reduced through removal of favorable habitat by maintaining a bare soil area 10 to 20 ft wide around the catchment apron (9). Insects may be controlled by proper application of approved insecticides, using care to prevent contaminating the runoff water. All sediment traps and trash screens should be cleaned during every visit to the system. Control of weeds on and around the catchment area also reduces the possibility of plant growth damaging the treatment or of windblown plant material plugging the sediment traps and trash screens or getting into the storage tank.

Some catchment treatments (asphalt-fabric) require a scheduled periodic retreatment of the surface. Renovating the catchment before complete failure will be less expensive than a complete reconstruction and will significantly increase the projected life of the treatment. New seal coats should be applied to asphalt-fabric catchments before the base fabric is damaged by weathering, usually at 3- to 5-year intervals. On water repellent soil catchments, unanticipated erosion can be controlled by installation of lined collection ditches and spot treatment of eroded areas. Similarly, patching and spot application of additional gravel will be needed on gravel-covered plastic membranes, and loose nails must be replaced on sheet metal catchments.

A good maintenance program is cheap insurance. Inadequate maintenance will prove costly. *Failure to maintain a water-harvesting system will result in failure of the system.*

Section 9.—Water Quality

The water quality standards for domestic use and animal drinking water are presented in tables 6, 7, and 8. With few exceptions, precipitation contains no contaminants harmful to animals or humans.

Water collected from a catchment surface can contain water-soluble impurities from windborne dust deposited on the catchment surface or weathering byproducts of the materials used to waterproof the catchment. Asphaltic surfaces deteriorate, by a combination of light, heat, and oxygen, into water-soluble degradation products, which discolor runoff water. The deterioration rate of asphaltic surfaces can be reduced by the application of protective coatings, and the discoloration particles in the runoff water can be removed by anionic exchange resin columns (25). Animal feces can biologically contaminate the runoff water.

Table 6.—Maximum allowable concentrations of chemical substances for domestic drinking water supplies (37, 43)

Constituent	Concentration
	Milligrams per liter
Arsenic	0.01
Ammonia nitrogen	.5
Barium	1.0
Boron	.01
Cadmium	.01
Chloride	250.00
Chromium (hexavalent)	.05
Copper	1.00
Iron	.30
Lead	.05
Manganese	.05
Mercury	.002
Nitrate (NO ₃)	10.00
Nitrite (NO ₂)	1.00
Selenium	.01
Silver	.05
Sulfate (SO ₄)	250.00
Zinc	5.00

Table 7.—Recommendations for levels of toxic substances in drinking water for livestock (37)

Constituent	Concentration
	<i>Milligrams per liter</i>
Aluminum	5.00
Arsenic	.20
Boron	5.00
Cadmium	.05
Chromium	1.00
Cobalt	1.00
Copper	.50
Lead	1.10
Mercury	.01
Nitrate plus nitrite	100.00
Nitrite	10.00
Selenium	.05
Vanadium	.10
Zinc	25.00

¹Lead is accumulative, and problems may begin at threshold value of 0.05 mg/L.

Quantitative information on the quality of water collected by a water-harvesting system is limited. Table 9 summarizes the analysis for various inorganic elements in water collected from different types of catchment surfaces located in Hawaii and Arizona (20). None of the elements existed in quantities that exceeded animal drinking water standards. Some elements detected may have come from windborne dust deposited on the catchment surface. Near mines or manufacturing plants, rainfall could also trap some elements. Limited biological analysis showed that some form of water treatment, such as chlorination, would be necessary to meet biological standards for potable water (19). Water-harvesting systems supplying water for household domestic use must be equipped with approved filtration (sand) and chlorination accessories.

Table 8.—Guide to the use of saline waters for livestock and poultry (37)

Total soluble salts content of waters (mg/L)	Remarks
Less than 1,000	Relatively low level of salinity. Excellent for all classes of livestock and poultry.
1,000–3,000	Very satisfactory for all classes of livestock and poultry. May cause temporary and mild diarrhea in livestock not accustomed to them or water droppings in poultry.
3,000–5,000	Satisfactory for livestock, but may cause temporary diarrhea or be refused at first by animals not accustomed to them. Poor waters for poultry, often causing water feces, increased mortality, and decreased growth, especially in turkeys.
5,000–7,000	Can be used with reasonable safety for dairy and beef cattle, sheep, swine, and horses. Avoid use for pregnant or lactating animals. Not acceptable for poultry.
7,000–10,000	Unfit for poultry and, probably, swine. Considerable risk in using for pregnant or lactating cows, horses, or sheep or for the young of these species. In general, use should be avoided, although older ruminants, horses, poultry, and swine may subsist on them under certain conditions.
Over 10,000	Risks with these highly saline waters are so great that they cannot be recommended for use under any condition.

Table 9.—Summary of analysis of elements from samples collected from various water-harvesting catchment surfaces (20)

Constituent	Parts per million				Galvanized steel
	Asphalt	Paraffin wax	Butyl	Silicone water repellent	
Cadmium	—	—	<0.001	—	<0.008
Calcium	0.5–35.0	6.4–46.0	2.1–32.0	3.8–14.0	(¹)
Chromium	<.002	<.009	<.02	<.006	<.01
Iron	<.0008	<.009	<.02	<.003	<.01
Lead	<.01	<.02	<.03	<.02	<.01
Magnesium	0.1–6.0	0.7–6.0	0.4–2.0	0.5–2.0	ND
Mercury	<.0007	<.0009	<.001	<.0008	<.0005
Potassium	0.3–6.0	1.2–16.0	0.7–2.0	0.9–5.0	ND
Sodium	0.2–12.0	0.4–8.0	0.5–1.0	0.9–9.0	ND
Zinc	<.004	<.003	<.01	<.0001	0.2

¹None detected.

Literature Cited

(1) American Society of Agricultural Engineers. 1980. Installation of flexible membrane linings. American Society of Agricultural Engineers Engineering Practice: ASAE EP340.1, Agricultural Engineers Yearbook, p. 476-481.

(2) Burdass, W. J. 1975. Water harvesting for livestock in Western Australia. *In* Proceedings of the Water Harvesting Symposium, Phoenix, Arizona, March 26-28, 1974. U.S. Department of Agriculture, Agricultural Research Service, ARS-W-22:8-26.

(3) Cluff, C. B. 1967. Water harvesting plan for livestock or home. *Progressive Agriculture in Arizona* 19(3):6-8.

(4) Cooley, K. R. 1970. Evaporation from open water surfaces in Arizona. University of Arizona, Agricultural Experiment Station and Cooperative Extension Service Folder 159, 2 p.

(5) ———. 1975. Evaporation for conserving water supplies. *In* Proceedings of the Water Harvesting Symposium, Phoenix, Arizona, March 26-28, 1974. U.S. Department of Agriculture, Agricultural Research Service, ARS-W-22:192-200.

(6) ———. Frasier, G. W., and Drew, K. R. 1978. Water harvesting: An aid to range management. *In* Proceedings of the First International Rangeland Congress, Denver, Colorado. Society for Range Management, p. 292-294.

(7) Crow, F. R., and Manages, H. L. 1967. Comparison of chemical and non-chemical techniques for suppressing evaporation from small reservoirs. *Transactions, American Society of Agricultural Engineers* 10(2): 172-174.

(8) Dedrick, A. R. 1973. Evaluating outdoor weatherability of butyl rubber sheeting under stress. *Transactions, American Society of Agricultural Engineers* 16(4):769-772.

(9) ———. 1973. Raintrap performance on the Fishlake National Forest. *Journal of Range Management* 26(1): 9-12.

(10) ———. 1974. Air pressure over surfaces exposed to wind. I. Water harvesting catchments. *Transactions, American Society of Agricultural Engineers* 17(5):917-920.

(11) ———. 1975. Air pressure over surfaces exposed to wind. II. Reservoirs. *Transactions, American Society of Agricultural Engineers* 18(3):508-513.

(12) ———. Hansen, T. D., and Williamson, W. R. 1973. Floating sheets of foam rubber for reducing stock tank evaporation. *Journal of Range Management* 26(6): 404-406.

(13) ———. and Lauritzen, C. W. 1969. A water storage structure for small systems. *Utah Science*, September. P. 63-64.

(14) Dutt, G. R., and McCreary, T. W. 1975. Multipurpose salt treated water harvesting system. *In* Proceedings of the Water Harvesting Symposium, Phoenix, Arizona, March 26-28, 1974. U.S. Department of Agriculture, Agricultural Research Service, ARS-W-22:310-314.

(15) Evenari, M. L., Shanan, L., Tadmar, N., and Aharoni, Y. 1961. Ancient agriculture in the Negev. *Science* 133: 979-996.

(16) Fink, D. H., Cooley, K. R., and Frasier, G. W. 1973. Wax-treated soils for harvesting water. *Journal of Range Management* 26(6):396-398.

(17) ———. Frasier, G. W., and Cooley, K. R. 1980. Water harvesting by wax-treated soil surfaces: Progress, problems, and potential. *Agricultural Water Management* 3: 125-134.

(18) ———. Frasier, G. W., and Myers, L. E. 1979. Water harvesting treatment evaluation at Granite Reef. *American Water Resources Association, Water Resources Bulletin* 15(3):861-873.

(19) Frasier, G. W. 1979. The use of wax-fiberglass as a catchment surface for water harvesting in Hawaii. Division of Water and Land Development, Department of Land and Natural Resources, State of Hawaii Circular No. C79, 33 p.

(20) ———. 1980. Harvesting water for agricultural, wildlife, and domestic uses. *Journal of Soil and Water Conservation* 35(3):125-128.

(21) ———. 1980. Lower cost water harvesting systems for range, wildlife, and livestock water. Final Report of Cooperative Study Between Bureau of Land Management, U.S. Department of Interior, and the Southwest Rangeland Watershed Research Center, Agricultural Research Service, U.S. Department of Agriculture, Tucson, Arizona. Unpublished. 42 p.

- (22) ——— 1981. Water for animals, man, and agriculture by water harvesting. *In* Proceedings of the U.S.-Mexico Resource Workshop, Rainfall Collection for Agriculture in Arid and Semiarid Regions, University of Arizona, Tucson. p. 83-86.
- (23) ——— Cooley, K. R., and Griggs, J. R. 1979. Performance evaluation of water harvesting catchments. *Journal of Range Management* 32(6):453-456.
- (24) ——— and Myers, L. E. 1968. Stable alkanol dispersion to reduce evaporation. *Proceedings of the Journal of the Irrigation and Drainage Division, American Society of Civil Engineers* 94(IR1):79-89.
- (25) ——— and Myers, L. E. 1970. Protective spray coatings for water harvesting catchments. *Transactions, American Society of Agricultural Engineers* 13(3):292-294.
- (26) Garver, H. L. 1948. Safe water for the farm. U.S. Department of Agriculture, *Farmers' Bulletin* No. 1978, 46 p.
- (27) Hanson, C. L., Neff, E. L., and Woolhiser, D. A. 1975. Hydrologic aspects of water harvesting in the northern Great Plains. *In* Proceedings of the Water Harvesting Symposium, Phoenix, Arizona, March 26-28, 1974. U.S. Department of Agriculture, Agricultural Research Service, ARS-W-22:129-140.
- (28) Hardan, A. 1975. Discussion: Session 1. *In* Proceedings of the Water Harvesting Symposium, Phoenix, Arizona, March 26-28, 1974. U.S. Department of Agriculture, Agricultural Research Service, ARS-W-22:6.
- (29) Lauritzen, C. W. 1960. Ground covers for collecting precipitation. *Farm and Home Science* 21:66-67, 87.
- (30) ——— 1967. Rain traps of steel. *Utah Science*, September. p. 79-81.
- (31) Matlock, W. G., and Shaw, R. J. 1966. Rainfall Collection for domestic water supplies. *Progressive Agriculture in Arizona* 18(4):10-11.
- (32) Myers, L. E. 1975. Water harvesting—2000 BC to 1975 AD. *In* Proceedings of the Water Harvesting Symposium, Phoenix, Arizona, March 26-28, 1974. U.S. Department of Agriculture, Agricultural Research Service, ARS-W-22:1-7.
- (33) ——— 1965. Water harvesting with plastic films. *Proceedings, Sixth National Agricultural Plastics Conference*, Phoenix, Arizona.
- (34) ——— 1961. Waterproofing soil to collect precipitation. *Journal of Soil and Water Conservation* 16(6): 281-282.
- (35) ——— and Frasier, G. W. 1974. Asphalt-fiberglass for precipitation catchments. *Journal of Range Management* 27(1):12-15.
- (36) National Academy of Sciences. 1953. Ferrocement: Applications in developing countries. Report of an Ad Hoc Panel of the Advisory Committee on Technological Innovation, Board on Science and Technology for International Development, Office of the Foreign Secretary, National Academy of Sciences, Washington, D.C. 89 p.
- (37) National Academy of Sciences-National Academy of Engineering. 1972. Water quality criteria 1972. Report of the Committee on Water Quality Criteria, Environmental Studies Board, National Academy of Sciences-National Academy of Engineering, Washington, D.C. 592 p.
- (38) Ree, W. O., Wimberley, F. L., Gwinn, W. R., and Lauritzen, C. W. 1971. Rainfall harvesting system design. U.S. Department of Agriculture, Agricultural Research Service, ARS 41-184, 12 p.
- (39) Reginato, R. J., Nakayama, F. S., and Miller, J. B. 1973. Reducing seepage from stock tanks with uncompacted sodium-treated soils. *Journal of Soil and Water Conservation* 25(5):214-215.
- (40) Sneva, F. A. 1979. Cool, clear water—water—water. *In* Special Report No. 549, Oregon Agricultural Experiment Station, Oregon State University, Corvallis.
- (41) U.S. Department of Agriculture. 1973. Hauling water to livestock on the range. *Technical Notes*, Soil Conservation Service, Utah. 3 p.
- (42) ——— 1973. Wildlife watering facility. *Technical Notes*. Soil Conservation Service, New Mexico. 3 p.
- (43) U.S. Department of Health, Education, and Welfare. 1962. Public Health Service drinking water standards. (Revised 1962) Public Health Service Publication No. 956, 61 p.
- (44) Velasco, H. A., and Carmona, G. 1980. Cosecha de agua de lluvia para consumo humano, consumo pecuario y agricultura de secano. *Primer Reporte de Evaluacion, Comision Nacional de las Zonas Aridas, Instituto Tecnológico y de Estudios Superiores de Monterrey*. 33 p.
- (45) Welchert, W. T., and McDougal, J. N., Jr. 1965. How to make a plastered concrete water-storage tank. *University of Arizona, Cooperative Extension Service and Agricultural Experiment Station Bulletin* No. A-41. 12 p.
- (46) Woodbury, R. B. 1963. Indian adaptations to arid environments. *In* *Aridity and Man*. Publication No. 74, American Association for the Advancement of Science, Washington, D.C. P. 55-85.

Appendix 1.—Computation of Catchment and Storage Sizes

Description

The sizes of catchment area and storage volume for the water-harvesting system with the lowest total installation cost can be determined with the aid of small desk-top calculators. The following program was developed for use with the Texas Instruments (TI) 58 or 59 Programmable Calculators. The program uses the metric system. English units must be converted before entry.

Table 10 presents a listing of the program. Figures 44 through 47 are flow diagrams of the program. Monthly rainfall data (in millimeters) are entered for a 12-month period (runoff per unit area) (table 11). For catchment treatments with runoff efficiencies less than 100 percent, the monthly rainfall inputs must be correspondingly reduced (rainfall times runoff efficiency) to obtain runoff per unit area. Monthly water requirements or use (in liters) for the same 12-month period are entered. (Enter zero for each period with no use.) The rainfall and use data are often entered based on a calendar year. Since the program always assumes there is no water in storage at the start of the 12-month period, a more realistic representation of normal field operations can be achieved by entering the data in some other 12-period sequence (that is, July to June).

Table 10.—Listing of program for computing optimum sizes of catchment and storage

LOC	CODE	KEY	COMMENTS
0	76	LBL	ENTER MONTHLY
1	11	A	RAINFALL DATA
2	00	0	
3	42	STO	INITIALIZE
4	00	00	REG 00 and 25 = 0
5	42	STO	
6	25	25	
7	91	R/S	ENTER DATA (RAIN)
8	69	OP	00 = 00 + 1
9	20	20	
10	72	STO IND	DATA STORED
1	00	00	IN REG 01 to 12
2	44	SUM	
3	25	25	25 = Σ RAIN
4	61	GTO	
5	00	0	LOOP TO
6	07	07	LOCATION 007
7	76	LBL	ENTER MONTHLY
8	12	B	USE DATA
9	00	0	
20	42	STO	INITIALIZE REG
1	26	26	26 = 0
2	01	1	
3	02	2	

Table 10.—Listing of program for computing optimum sizes of catchment and storage—Continued

LOC	CODE	KEY	COMMENTS
4	42	STO	RESET 00 = 12
5	00	00	
6	91	R/S	ENTER DATA
7	69	OP	
8	20	20	00 = 00 + 1
9	72	STO IND	DATA STORED
30	00	00	IN REG 13 to 24
1	44	SUM	
2	26	26	26 = Σ USE
3	61	GTO	
4	00	0	LOOP TO
5	26	26	LOCATION 026
6	76	LBL	COMPUTE INITIAL
7	13	C	CATCH AND STORE
8	43	RCL	SIZE
9	26	26	X = Σ USE
40	55	$\frac{\square}{\square}$	
1	43	RCL	X = Σ USE/ Σ RAIN
2	25	25	
3	95	=	X = AREA
4	42	STO	
5	29	29	29 = 1st AREA
6	86	ST FLAG	
7	04	4	INITIAL FLAG 4
8	76	LBL	
9	19	D'	LABEL (D')
50	87	IF FLAG	CONDITIONAL
1	04	4	BRANCH
2	34	\sqrt{x}	GO TO (\sqrt{x})
3	93	.	
4	08	8	X = .8
5	49	PRD	DECREASE STORAGE
6	28	28	28 = (0.8)(28)
7	61	GTO	
8	42	STO	GO TO (STO)
9	76	LBL	
60	34	\sqrt{x}	LABEL (\sqrt{x})
1	00	0	
2	42	STO	28 = 0
3	28	28	
4	76	LBL	
5	42	STO	LABEL (STO)
6	00	0	
7	42	STO	27 00 = 0
8	27	27	
9	42	STO	
70	00	00	
1	32	X \longleftrightarrow T	T = 0
2	76	LBL	
3	22	INV	LABEL (INV)
4	69	OP	
5	20	20	00 = 00 + 1
6	73	RCL IND	
7	00	00	X = RAIN(I)
8	65	X	
9	43	RCL	

Table 10.—Listing of program for computing optimum sizes of catchment and storage—Continued

LOC	CODE	KEY	COMMENTS
80	29	29	29 = AREA
1	95	=	X = R(I) x AREA
2	44	SUM	27 = TEMP STORAGE
3	27	27	27 = 27 + R(I)A
4	01	1	
5	02	2	
6	44	SUM	
7	00	00	00 = 00 + 12
8	73	RCL IND	
9	00	00	X = USE(I)
90	22	INV	
1	44	SUM	27 = 27 + R(I)
2	27	27	-USE(I)
3	43	RCL	
4	27	27	X = STORAGE
5	77	X > T	STORAGE > 0
6	23	LNK	GO TO (LNK)
7	01	1	
8	93	.	
9	00	0	
100	05	5	X = 1.05
1	49	PRD	INCREASE
2	29	29	AREA 5%
3	87	IF FLAG	CONDITIONAL
4	04	4	BRANCH
5	19	D'	GO TO (D')
6	61	GTO	
7	42	STO	GO TO (STO)
8	76	LBL	
9	23	LNK	LABEL (LNK)
110	75	-	
1	43	RCL	X = (STORAGE-
2	28	28	MAX STORAGE)
3	95	=	
4	77	X > T	X > 0
5	24	CE	GO TO (CE)
6	61	GTO	
7	32	X <—> T	GO TO (X <—> T)
8	76	LBL	
9	24	CE	LABEL (CE)
120	87	IF FLAG	CONDITIONAL
1	04	4	BRANCH
2	43	RCL	GO TO (RCL)
3	43	RCL	
4	28	28	X = MAX STOR
5	42	STOR	
6	27	27	27 = MAX STOR
7	61	GTO	
8	32	X <—> T	GO TO (X <—> T)
9	76	LBL	
130	43	RCL	LABEL (RCL)
1	43	RCL	
2	27	27	X = STORAGE
3	42	STO	
4	28	28	28 = STORAGE
5	76	LBL	
6	32	X <—> T	LABEL (X <—> T)
7	43	RCL	

LOC	CODE	KEY	COMMENTS
8	00	00	X = COUNTER
9	75	-	
140	02	2	
1	04	4	X = (COUNT-24)
2	95	=	
3	67	X = T	IF X = T
4	25	CLR	GO TO (CLR)
5	43	RCL	
6	00	00	X = COUNT
7	75	-	
8	01	1	
9	02	2	
150	95	=	
1	42	STO	00 = 00 -12
2	00	00	
3	61	GTO	
4	22	INV	GO TO (INV)
5	76	LBL	
6	25	CLR	LABEL (CLR)
7	91	R/S	
8	76	LBL	
9	14	D	LABEL (D)
160	22	INV	
1	86	ST FLAG	RESET FLAG
2	04	4	4
3	61	GTO	
4	19	D'	GO TO (D')
5	76	LBL	
6	15	E	LABEL (E)
7	93	.	
8	00	0	
9	00	0	
170	01	1	X = .001
1	42	STO	
2	27	27	27 = .001
3	43	RCL	
4	29	29	X = AREA
5	42	STO	
6	00	0	00 = AREA
7	91	R/S	ENTER AREA COST
8	49	PRD	
9	00	00	00 = CATCHMENT
180	43	RCL	TOTAL COST
1	00	00	
2	91	R/S	ENTER STORAGE
3	49	PRD	COST
4	27	27	
5	43	RCL	
6	28	28	X = STORAGE
7	91	R/S	
8	49	PRD	
9	27	27	27 = STORAGE
190	43	RCL	TOTAL COST
1	27	27	
2	91	R/S	
3	44	SUM	
4	00	00	00 = TOTAL COST
5	43	RCL	
6	00	00	

Table 10.—Listing of program for computing optimum sizes of catchment and storage—Continued

LOC	CODE	KEY	COMMENTS
7	91	R/S	
8			
9			

The program estimates an initial catchment size based on total precipitation and total use for the 12-month period, then computes a storage volume that allows for no spill or overflow. A water balance procedure is used to check that the rainfall collected in a period, plus any carryover water in storage, always exceeds the water requirement (use) for the period.

$$\text{Rainfall} \times \text{area} + \text{carryover} > \text{use} \quad (1)$$

If, during a period, there is insufficient water to meet the needs, the catchment area is increased by 5 percent and the water balance is rechecked by periods.

This procedure is continued, with the catchment area being increased 5 percent each time, until the water balance shows sufficient water for each period. Unit catchment costs (in dollars per square meter) and storage

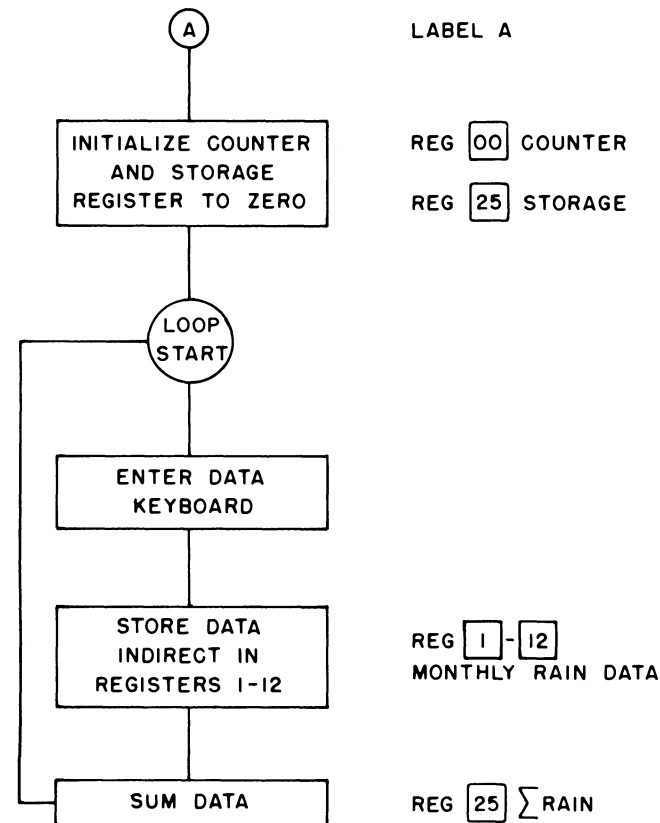

Figure 44.—Flow diagram for entry of monthly rainfall amounts.

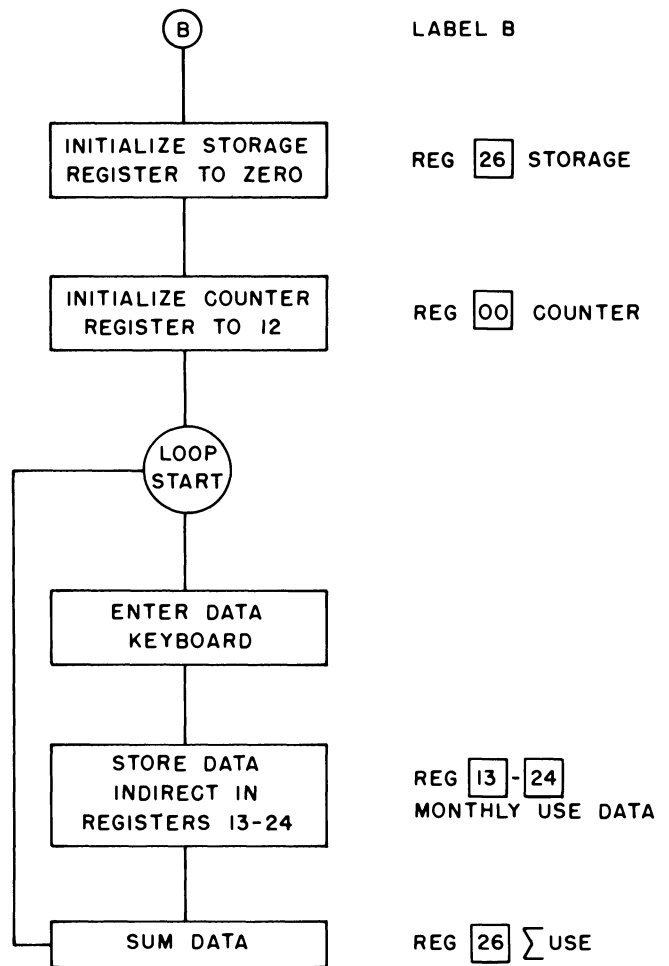

Figure 45.—Flow diagram for entry of monthly water use amounts.

costs (in dollars per 1000 L) are entered, and the size of catchment (in square meters), cost of catchment (in dollars), size of storage (in liters), cost of storage (in dollars), and total system cost (in dollars) are recorded.

The storage size is then reduced by 20 percent (spill or overflow from storage will occur), and a new catchment size is computed. The revised costs and sizes are recorded. This procedure is continued until a minimum total system cost is achieved. The catchment area and storage volume of the lowest total cost are the design sizes.

Example

The following is an example using the program. The input data are the same as the example in section 4. Table 11 is the input data for the example. Note that the rainfall data are converted to metric measurements (millimeters) then reduced by 10 percent to allow for the correction due to location (X.9) and reduced by another 5 percent to allow for catchment efficiency (X.95).

Program Instructions

Step	Procedure	Enter	Press	Display
1	Partition memory to a minimum of 30 storage registers			
2	Clear storage registers.			
3	Enter program.			
4	Start—Rainfall data entry. Enter monthly rainfall in millimeters; continue 12 times representing 12 months.	—	A R/S	0 Rain (I).
5	Use data entry. Enter monthly use in liters; continue 12 times representing 12 months.	Use (I)	B R/S	12 Use (I).
6	Compute initial catchment size and storage volume (running time 2 to 5 min).		C	0
7	Record computed sizes and costs. (a) Record catchment size (m ²). (b) Enter unit catchment cost (\$/m ²). (c) Record catchment cost (\$). (d) Enter unit storage cost (\$/1000 L). (e) Record storage size (L). (f) Record storage cost (\$). (g) Record total system cost (\$).	Unit cost Unit cost	R/S R/S R/S	Size of catchment. Cost of catchment. Size of storage. Cost of storage. Total system cost.
8	Compute next size of catchment and storage (storage reduced 20 percent) (running time 2 to 5 min).		D	0
9	Do step 7.			
10	Continue steps 8 and 7 until total cost is minimum.			

User Defined Labels

- A - Enter rainfall data (monthly).
- B - Enter use data (monthly).
- C - Compute first approximation of catchment and storage sizes.
- D - compute catchment size with storage reduced 10 percent.
- E - Display sizes and compute costs.
- D' - Branch index

Labels Used for Branching

INV, LNX, CE, CLR, X ↔ T, \sqrt{x} , STO, RCL

Data Registers

- 00 - Counter.
- 01 - Monthly rainfall data.
- 12 - Monthly use data.
- 13 - Monthly use data.
- 24 - Summation rain.
- 25 - Summation use.
- 27 - Intermediate storage sizes for computations (STR).
- 28 - Maximum storage size (STO).
- 29 - Catchment size.

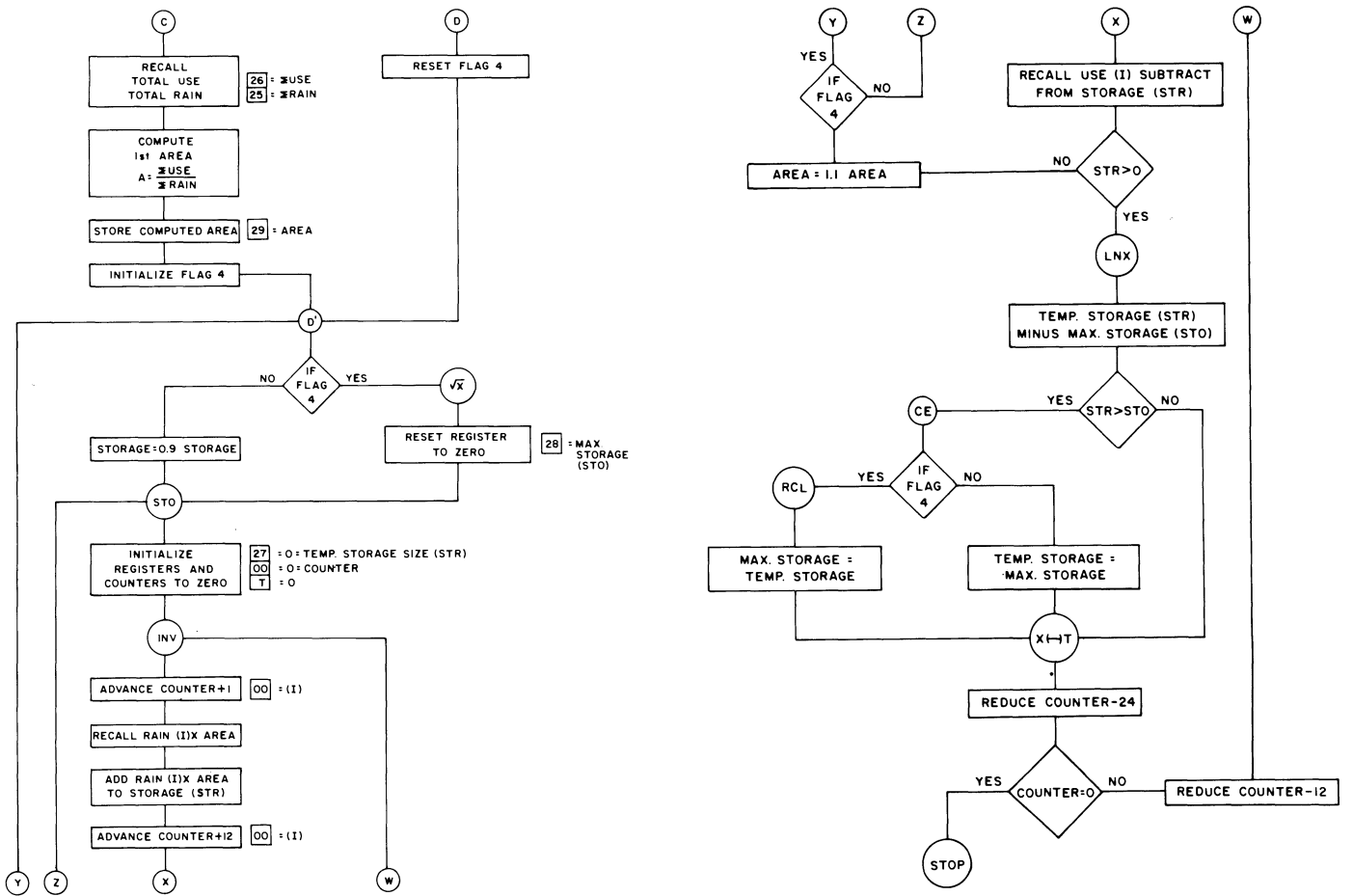

Figure 46.—Flow diagram for computation of catchment and storage sizes.

The results of the catchment and storage sizing computations are presented in table 12. For runs 1 through 9, January is the starting month. For runs 1A through 7A, June is the starting month. The June starting data are a more realistic starting point, as there may be years when below-normal rainfall in May would result in an empty storage at the start of the June period.

Table 11.—Input data for sizing catchment and storage in example 1 using procedure described in appendix 1

Month	Runoff per unit area ¹		Water requirement	
	Millimeters	Gallons	Liters	
Jan.	48	1,800	7 000	
Feb.	48	1,800	7 000	
Mar.	44	19,800	80 000	
Apr.	33	19,800	80 000	
May	15	19,800	80 000	
June	11	1,800	7 000	
July	68	1,800	7 000	
Aug.	74	1,800	7 000	
Sept.	35	1,800	7 000	
Oct.	31	1,800	7 000	
Nov.	27	19,800	80 000	
Dec.	48	19,800	80 000	

¹Runoff per unit area (millimeters) = rainfall (inches) × 25.4 (mm/inch) × correction for location × catchment efficiency.

Table 12.—Results of catchment and storage sizes for example 1 using the procedure described in appendix 1

Run No.	Catchment		Storage		Total cost
	Area	Cost	Volume	Cost	
	Square meters		Liters		Dollars
1	1376	4,128	271 154	10,034	14,162
2	1376	4,128	216 923	8,025	12,153
3	1376	4,128	173 539	6,419	10,547
4	1376	4,128	138 831	5,135	9,263
5	1445	4,335	111 065	4,110	8,445
6	1673	5,019	88 852	3,289	8,308
7	1937	5,811	71 082	2,630	8,441
8	2242	6,726	56 865	2,105	8,831
9	2472	7,416	45 492	1,683	9,099
1A	978	2,934	179 206	6,630	9,564
2A	1078	3,234	143 365	5,305	8,539
3A	1376	4,128	114 692	4,243	8,371
4A	1673	5,019	91 753	3,396	8,415
5A	1844	5,532	73 403	2,715	8,247
6A	2135	6,405	58 722	2,171	8,576
7A	2472	7,416	46 978	1,739	9,155

¹Based on \$3/m².

²Based on \$37/1000 L.

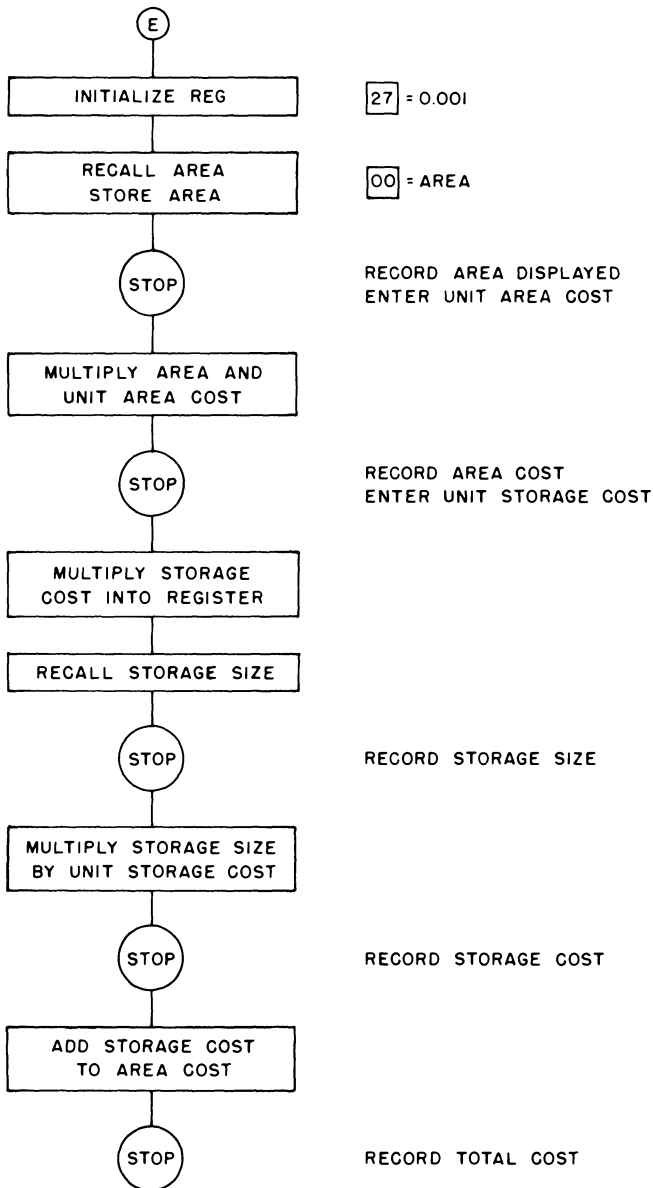

Figure 47.—Flow diagram for computing costs of catchment and storage.

Appendix 2.—Test for Soil Compatibility of the Paraffin-Wax Treatment

Soil samples representative of the 0- to 2-inch depths of the cleared catchment surface are taken. Each area with

visually different physical or chemical soil properties should have a separate sample taken.

Each soil sample is airdried (24 to 48 hr), rolled or crushed to break down large soil aggregates, and sieved through a No. 10 sieve (1.981 mm). The sieved soil is placed in a shallow pan or container with a minimum depth of one-half inch (preferably, a glass petri dish 3½ inches in diameter and ½ inch deep), and the surface smoothed. The soil is wetted with sufficient water to penetrate approximately one-quarter inch. Three to four hours later, additional water, sufficient to moisten but not saturate the full soil depth, is applied and the moist soil compacted with a flat object such as a large rubber stopper. The sample is airdried for 1 to 2 days. Granulated wax or chips of wax are spread on the dried surface at a rate of 2 lb/yd², and the sample is placed in a 160° to 180°F oven for 1 hr. After the wax has melted into the soil, the sample is removed from the oven and cooled to room temperature.

The treatment effectiveness is evaluated by observing, over a period of several hours, a drop of water, approximately one-quarter inch in diameter, placed on the soil surface. On a highly water repellent soil, the droplet assumes a spherical shape with small air bubbles trapped between the soil surface and the water drop. This condition is assigned a rating of 8. Complete absence of water repellency, that is, the drop soaks immediately into the soil, is assigned a rating of 0. On soils partially water repellent, the drop gradually increases in diameter, wets the soil surface, and eventually infiltrates into the soil. A rating of between 0 and 8 is assigned, depending upon the visual appearance of the droplet (fig. 48). The water drop is rated at 1-hr intervals over a period of 6 hr. Table 13 gives a criteria of treatment suitability based on the waterdrop rating.

Table 13.—Wax treatment suitability relative to water repellency drop evaluation

Treatment suitability	Time in hours					
	1	2	3	4	5	6
Unsatisfactory	5	3	1	1	0	0
Poor	6	4	3	2	2	2
Fair	7	6	5	4	4	3
Satisfactory	7	7	6	5	4	4
Good	8	7	7	6	6	5
Excellent	8	8	8	7	7	7

HIGHLY WATER-REPELLENT
SURFACE RATING - 8

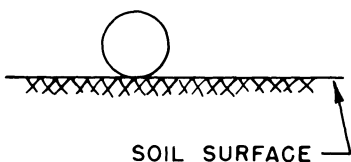

PARTIALLY WATER-REPELLENT
SURFACE RATING - 3 TO 6

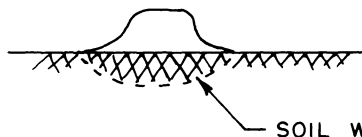

WETTABLE SOIL
SURFACE RATING - 1

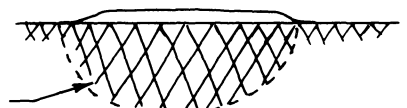

Figure 48.—Drop appearance for different degrees of water repellency.