



AgEcon SEARCH
RESEARCH IN AGRICULTURAL & APPLIED ECONOMICS

The World's Largest Open Access Agricultural & Applied Economics Digital Library

This document is discoverable and free to researchers across the globe due to the work of AgEcon Search.

Help ensure our sustainability.

Give to AgEcon Search

AgEcon Search

<http://ageconsearch.umn.edu>

aesearch@umn.edu

*Papers downloaded from **AgEcon Search** may be used for non-commercial purposes and personal study only. No other use, including posting to another Internet site, is permitted without permission from the copyright owner (not AgEcon Search), or as allowed under the provisions of Fair Use, U.S. Copyright Act, Title 17 U.S.C.*

No endorsement of AgEcon Search or its fundraising activities by the author(s) of the following work or their employer(s) is intended or implied.

Ag 84 Mr
Cap. 5

DESIGNING SHELL EGG GRADING AND PACKING PLANTS

PRODUCTION
CURRENT SERIAL RECORDS

FEB 8 '80

U.S.D.A.
NATIONAL LIBRARY
ED.



UNITED STATES
DEPARTMENT OF
AGRICULTURE

MARKETING
RESEARCH
REPORT
NUMBER 1105

PREPARED BY
SCIENCE AND
EDUCATION
ADMINISTRATION

Historic, archived document

Do not assume content reflects current scientific knowledge, policies, or practices.

ABSTRACT

Goble, Jesse W. 1980. Designing shell egg grading and packing plants. U.S. Department of Agriculture, Marketing Research Report No. 1105, 32 pp.

In this report are discussed (1) the general principles of plant layout design, (2) methodology useful to a shell egg packing firm to analyze and determine its facility requirements, (3) the layouts and operational procedures designed for three typical firms to demonstrate how individual facility requirements can be satisfied, and (4) some benefits resulting from adequate layout planning.

KEYWORDS: Designing plants, egg grading, eggs, grading plants, packing plants, plant layout, shell egg plants.

CONTENTS

	Page
Principles of plant layout -----	2
Layout planning to meet specific needs -----	2
Firm A -----	2
Firm B -----	10
Firm C -----	15
Benefits provided by the layouts -----	22
Appendix -----	23
Data collection form -----	23
Analysis of firm A facility needs (tables 4-14)---	27

Issued January 1980

DESIGNING SHELL EGG GRADING AND PACKING PLANTS

By Jesse W. Goble 1/

Shell egg processing firms are often faced with making decisions about plants that are no longer efficient to operate or lack capacity to handle increasing production. Other plants may no longer be properly located to serve changing patterns of egg production that result in rising costs to assemble the eggs for processing.

The increasing costs of constructing and operating shell egg grading and packing plants necessitate careful planning for new or remodeled facilities. Not to be overlooked are the effects of economies of scale when deciding about the capacity of a facility. Too small a facility will not provide the operating efficiency attainable in larger ones. On the other hand, one built with excessive capacity will increase the investment unnecessarily and possibly affect operating efficiency because of wasted space. The expected egg volume to be handled must be realistically projected so that a facility can be designed for expansion later at minimum cost and with least disruption to the operation. The type of operation also affects the kind of packing facilities needed. The likelihood of relocating an established shell egg packing plant to an egg production farm complex and integrating it into the total operation at one location is a possibility for some firms. Others may require a centralized plant to process the eggs from flocks on several farms. Nevertheless shell egg grading and packing facilities should be planned for compatibility with the production operations and have the capacity to handle the volume generated.

Besides the volume to be handled, plant layout and space are also affected when more efficient grading and packing equipment is installed to increase processing capacity. However, to justify using equipment with specialized capabilities and improved materials-handling system to increase efficiency requires a sufficient volume of eggs. Equipment and handling systems have minimum space requirements that must be considered in designing a new plant or remodeling an existing one. Planning a facility that uses equipment with capacity greater than currently needed to satisfy projected needs that may not materialize can

1/ Formerly poultry marketing specialist, Animal Products Marketing Laboratory, now on the Joint Planning and Evaluation Staff, Science and Education Administration, Beltsville Agricultural Research Center, Beltsville, Md. 20705.

create built-in inefficiencies. Preferably the plant should be designed to handle efficiently the current volume with provision for expansion later if necessary. This applies to the equipment as well as the building.

The purpose of this report is to show how layout plans can be developed to satisfy the facility requirements of individual shell egg packing firms. Three firms chosen for study have needs somewhat typical of the industry. The layouts demonstrate how planning can reflect the needs of individual firms yet conform to basic principles of efficient plant design.

PRINCIPLES OF PLANT LAYOUT

Developing a satisfactory layout for a shell egg packing plant can be thought of as arranging the facility to provide the space needed for operating equipment, personnel, movement of material, and storage, along with necessary supporting activities and services. The operations are considered in the order performed. Travel distances are kept short and direct; congestion, delays, and interferences are held to a minimum; safety and protection of employees are provided for; nonproductive effort is minimized; and work is distributed as equally as possible among workers. The primary objective is to arrange equipment and work areas so they will be economical to operate, yet safe and satisfactory for employees without sacrificing product quality. To accomplish this by chance, however, is highly unlikely. All equipment in the layout should have a justifiable purpose. Each processing area should be located according to its functional relationship to the others so as to provide the most convenient, direct, and uninterrupted movement of materials and employees.

For an effective layout plan, various features and considerations must be observed in an orderly way. They include (1) building, (2) products and materials, (3) machinery, (4) workers, (5) movement, (6) delays, (7) services, and (8) ease of making changes.^{2/} To solve a particular layout problem necessitates compromising these features to achieve the objectives of the layout plan since the relationships are so intertwined that one feature may affect several others. Thus a situation may exist where to make "trade offs" is necessary. When a feature is disregarded that should be provided for, or an essential one is overlooked, a less than satisfactory layout may result.

LAYOUT PLANNING TO MEET SPECIFIC NEEDS

A layout should satisfy the particular needs of an individual firm. In this report the facility needs of three shell egg packing firms are analyzed and layouts are developed to meet their particular requirements.

Firm A

Background

The firm operates a central shell egg packing plant at the edge of a mid-size city. Eggs are trucked to the plant from production flocks owned by the

^{2/} Muther, Richard. Practical plant layout. 363 pp. McGraw Hill Pub. Co., New York. 1955.

company as well as from contract operations. Because of the high cost of transporting the eggs, the firm desires to relocate the packing facility at one of its egg production farms, where it will construct a production complex consisting of 50,000 birds.

At its present location, the packing operation and storage space for a small quantity of packaging material are in a building with offices and retail sales operations. The main supply of packaging material is stored in a nearby building, from which it is trucked to replenish supplies at the grading and packing facility.

Facility Requirements

The firm plans to transport ungraded eggs from nearby production houses to the packing plant on castered racks that hold 450 dozen eggs on filler-flats.^{3/} Loaded racks from adjacent production houses will be moved manually to the plant and those from more distant houses on the farm and from other locations will be transported on trucks.

The firm presently handles the production from approximately 300,000 layers. By 1982, the number of birds is expected to be increased to one-half million.^{4/} Assuming an average annual egg production rate of 65 percent, approximately 3,794 cases are produced weekly from the present flocks. In 5 years, production would likely increase 66 percent and total 6,321 cases weekly. The grading and packing of the eggs would be done in a 5-day workweek. An estimated annual average of 1 percent would be inedible and broken eggs and 5.5 percent would be undergrades that could be diverted to breaking stock. The total loss and undergrades would approximate 247 cases weekly at present production levels and 411 cases in 5 years. The net volume of graded eggs packed during the 5-day week would be 3,547 cases, of which 3,015 would be cartoned and 532 packed on filler-flats and placed in 30-dozen cases. In 5 years, the volume of cartoned eggs would increase to over 5,000 cases, which when added to those packed on filler-flats would total nearly 6,000 cases. This increasing production must be planned for in the plant layout.

Cooler space is needed presently for approximately 1,200 cases of incoming ungraded eggs, which would require 80 castered racks (table 1). In 5 years, an estimated 134 racks would be needed. After the eggs are graded and packed, assuming a 1½-day turnover, storage space would be needed for 43 pallets to hold an average inventory of 1,267 cases of eggs. If 10 percent more pallets are arbitrarily added to allow for partially filled ones, space would be needed for a total of 48. An additional seven pallets would be required for holding undergrade eggs designated as breaking stock, assuming a 7-day turnover. Thus space must be provided for a total of 55 pallets in the graded egg cooler, which would need to be increased in 5 years to hold 91 pallets of eggs.

^{3/} A data collection form is useful for obtaining information in an orderly way to determine space requirements. (See appendix.)

^{4/} For details of planning analyses, see tables 4-14 (appendix).

Table 1.--Storage space requirements

Item	Units	Handling equipment	Handling units	Space per handling unit	Total floor-space _{1/}
	<u>Number</u>		<u>Number</u>	<u>Ft²</u>	<u>Ft²</u>
Cooler:					
Eggs (cases): ^{2/}					
Ungraded-----	1,200	Racks--	80	8.3	664
Graded and undergrades-----	1,476	--do---	55	15.2	836
Dry storage:					
Packaging material (bundles):					
Cartons-----	4,500	Pallets	300	15.2	4,560
Cases-----	600	--do---	43	15.2	654
Filler-flats-----	2,250	--do---	113	15.2	1,718

1/ Does not include aisle space.

2/ 30-doz case or equivalent.

The estimated number of cartons used per week would require 29 pallets for storage and would increase to 47 in 5 years. Approximately 13 pallets are needed to hold the quantity of cases used per week and 22 pallet loads would be needed in 5 years. The number of filler-flats used per week presently requires four pallets and would increase to seven in 5 years.

The following average inventory of packaging material is maintained by the firm:

	<u>Bundles</u>
Cartons -----	3,600
Cases -----	300
Filler-flats ---	1,500

The following average quantities are received per truck delivery:

	<u>Bundles</u>
Cartons -----	900
Cases -----	300
Filler-flats ---	750

Although the number of racks and pallets needed to handle eggs by 1982 would increase by about two-thirds, the quantity of packaging material stored would not have to be increased if the assumption is made that more frequent deliveries could be received to avoid the added storage cost of a larger inventory.

Description of Proposed Plant

Building.--The preengineered structure is 140 by 90 feet with 12-foot eaves and a double-pitched roof. Insulation is provided by the manufacturer as an integral part of the building. The floors and the platform are the same level (fig. 1). Since the site slopes, a dirt fill creates a level area on which to locate the building. It also provides an area where the platform can be built at truck-bed height with little additional preparation.

Since retail sales are made on the premises, convenient access is provided to the building for persons other than employees so as not to interfere with the plant operation. The employee entrance is also used for incoming racks of eggs manually moved directly from adjacent production buildings to the processing area.

Plant Layout.--The receiving and shipping platform, 58 by 14 feet (outside dimensions), is at the side of the building where the earth fill makes the platform 46 inches above ground level. The platform is enclosed and has two overhead doors, 8 by 8 feet. A side door and steps leading to the platform provide workers access from outside the building.

Ungraded eggs are received at the plant on metal castered racks, 3 by 2 feet, with 5 shelves that hold 450 dozen eggs on filler-flats. The loaded racks are moved manually from trucks onto the platform and then to the receiving cooler. From there they are taken to the processing area. After the eggs are graded and packed there, they are moved to storage and then loaded from storage onto trucks from the same platform where they were received. Some of the platform space between the two cooler doors is used for temporarily storing racks when not in use.

The storage area consists of refrigerated (coolers) and nonrefrigerated space. The receiving cooler provides refrigerated storage for the ungraded eggs. After the eggs have been graded, they are held in a second cooler to await shipment. Separate coolers permit the ungraded and graded eggs to be held at optimum temperatures to maintain product quality. Furthermore, checked shells caused by the excessive temperature differential between the eggs and the wash water used in the cleaning process can be minimized, since ungraded eggs can be held at a higher temperature than graded eggs. Potential bacteriological problems can also be avoided that might otherwise occur when washed and unwashed eggs are stored in the same cooler. Moreover, separate coolers improve product flow and contribute to handling efficiency.

The receiving cooler for ungraded eggs is 37 by 35 feet with a 10-foot-high ceiling. It provides space for 112 racks positioned in rows on each side of an 8-foot aisle. Although the cooler is larger than needed for the present volume, the additional space is adequate for anticipated needs until 1982. The aisle can also be used for temporary storage if needed.

The shipping cooler for graded eggs is 43 by 35 feet. It provides space for 2,400 cases of eggs loaded on 80 pallets, each 4 by 3 feet. However, the effective capacity is less, since some pallets will be only partially filled because of different brands and sizes of eggs that are usually packed. The 8-foot-wide aisle can also be utilized temporarily for additional storage.

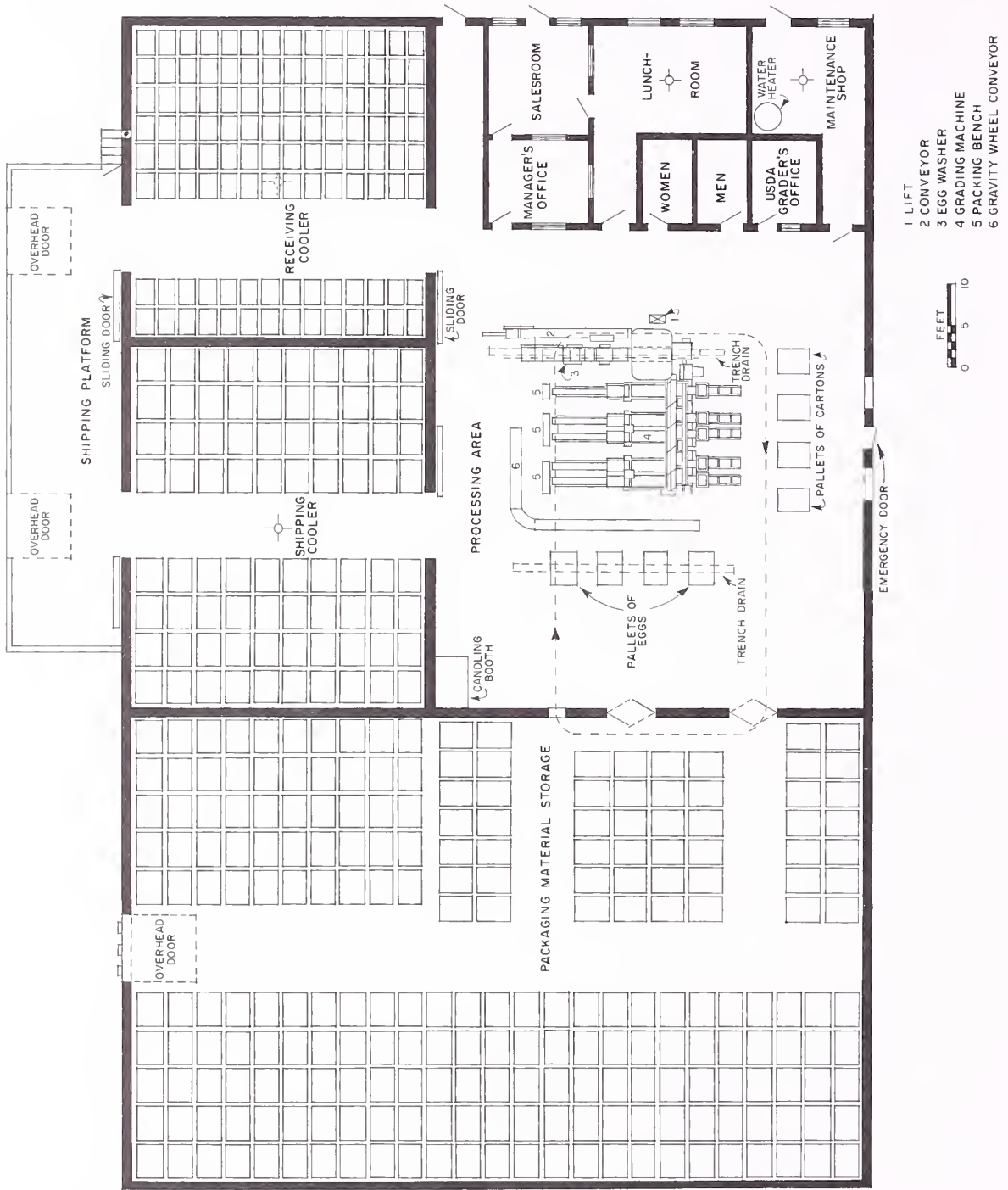

Figure 1.--Layout for firm A.

Each cooler has a 4-inch floor drain with a deep seal trap. By sloping the floor approximately one-eighth inch per foot to the drain, the floor can be kept clean by periodic washing. A curb 4 inches thick and 8 inches high with the top sloped outward should be constructed at the junction of the floor and walls to prevent pallet or rack damage to the walls.

The storage area for packaging material is 88 by 56 feet or 4,928 square feet. Bumpers attached to the building prevent damage to the outside wall from trucks backing up to the doorway. Packaging material is unloaded from trucks onto pallets and moved through an 8-foot overhead door to the storage area, where it is stored at least two tiers high to effectively utilize cubic space and thus reduce the square feet of floorspace needed. Although a forklift truck would be necessary to lift the pallets, it would cost less than constructing additional space that would be required if storage was limited to one tier.

Floorspace is provided for approximately 454 pallets if stacked 2 tiers high. Additional pallets can also be placed in the aisles temporarily when a new shipment is received. However, the average inventory of packaging material maintained by a firm is a management decision that affects the amount of space needed.

The wall separating the packaging material storage area from the processing area is nonload bearing so that it can be relocated to provide space for a second grading machine if necessary.

Pallets of cartons are transported from storage into the processing area through biparting doors, which also serve as a passageway for workers between the two areas. An overhead monorail conveyor with suspended "L" hooks transports made-up cases from storage to the carton packing stations. The conveyor also passes above the work station where racks of eggs are unloaded. If ungraded eggs are received in cases instead of on racks, the emptied cases can be hung on the hooks and either taken to the packing stations for refilling with cartoned eggs or moved to storage.

An alternative plan (not shown) is to transport the cases on pallets to the packing area and place them on a shelf above the conveyor back of the packing stations. After a case of cartoned eggs is placed on the conveyor, which moves it to the palletizing area, the packer would take an empty case from the overhead shelf and return to the packing station where the case would be filled with cartoned eggs.

The processing area is 57 by 52 feet, where the egg washer (3)^{5/} and grading machines or candler (4) are arranged for the most efficient flow of products and materials.

For sanitation purposes, two 12-inch-wide trench floor drains, each containing a 4 $\frac{1}{4}$ -inch outlet with deep seal trap, remove waste water and aid in maintaining a dry floor. The egg washer is positioned directly over one of the trench drains so that overflow and waste water will discharge directly into the

^{5/} Figures in parentheses refer to equipment in layouts (figs. 1, 3, and 4).

drain. The other drain would serve a second egg washer of the same capacity if the plant has to be expanded later.

Racks of eggs are moved manually from the receiving cooler and positioned on a lift (1) located next to the transfer conveyor (2). Flats of eggs are removed from the racks and placed on the conveyor, from which they are automatically transferred to the washer conveyor. The emptied racks and filler-flats are held temporarily in the receiving cooler and on the platform. After the eggs are washed, graded, and cartoned or placed on filler-flats and in cases, a worker manually places the filled cases on a gravity wheel conveyor (6), which moves them to a holding area for palletizing and subsequent transporting to the shipping cooler. The undergrade eggs are placed on filler-flats and stored in the shipping cooler on castered racks. Inedible eggs would be denatured and held in a cooler according to the provisions of the Egg Products Inspection Act of 1970.^{6/}

Palletized bundles of cartons are moved from the storage area to a position near the carton chutes of the grading machine. Empty racks are returned through the receiving cooler to the platform for temporary storage.

A candling booth (fig. 2) near the shipping cooler (fig. 1) aids in determining the quality of graded eggs as they come from the packing line and in rechecking the quality of graded eggs after they have been held in the shipping cooler for a sufficient time to cool. The booth should be constructed of sound-deadening material to reduce distracting noise that could affect the accuracy in detecting checked shells and evaluating other quality factors. An insulated curtain with a backing of foam rubber or comparable material can be used to close the booth when not in use. The ventilator on top should also be installed so that it is directed away from the source of greatest noise.

Trash from the grading and packing operations is held in a storage container near the receiving and shipping platform.

The auxiliary plant areas contain approximately 879 square feet of floor-space and include a manager's office, USDA grader's office, salesroom, employee facilities, and maintenance shop.

The manager's office is 12 by 10 feet with windows overlooking the processing activities, the adjoining salesroom, and the employee lunchroom. An office, 10 by 8 feet, is also provided for the USDA grader.

Since the firm retails some eggs, a salesroom, 13 by 12 feet, with a direct entrance from outside is provided for customers so that they do not have to enter other plant areas. The windows permit the sales operation to be overseen so that an employee does not have to be assigned full time to handle retail sales.

The employee lunchroom, 18 by 13 feet, has a concrete tile floor with a drain to facilitate sanitation. Equipment includes tables, chairs, and dispensers for food and beverage.

^{6/} Regulations Governing the Inspection of Eggs and Egg Products (7 CFR Part 59), Agricultural Marketing Service, U.S. Department of Agriculture, June 30, 1975.

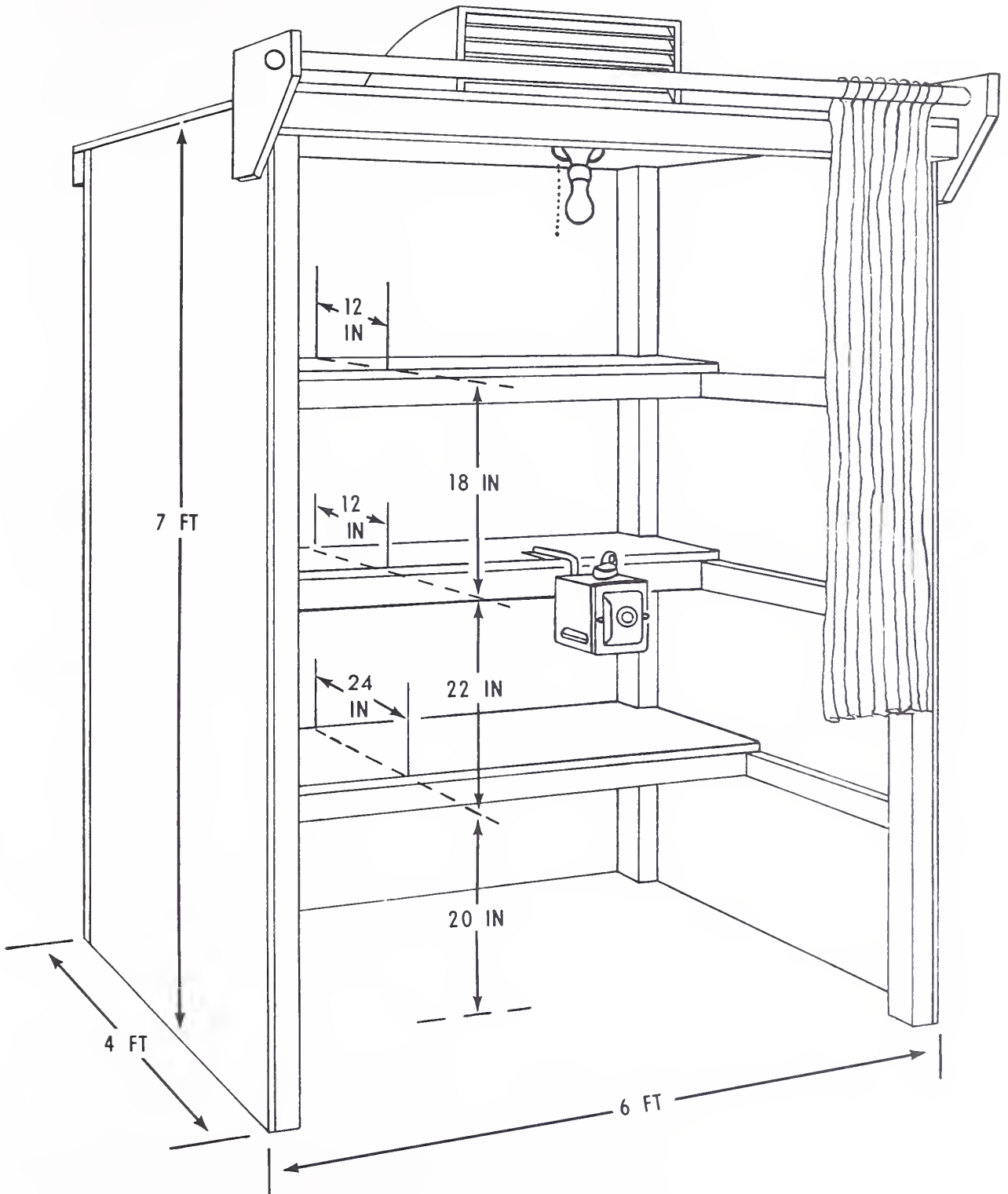

Figure 2.--Candling booth for periodically checking egg quality.

The women's and men's restrooms, each 10 by 6 feet, are mechanically ventilated to the outside and have self-closing doors. The number of sanitary facilities needed is specified in the guidelines prescribed by the U.S. Department of Agriculture regulations governing the inspection of eggs and egg products.

The maintenance shop, 13 by 13 feet, has a 5-foot-wide entrance. Shelves along one side of the entranceway provide storage space for supplies. A door to the outside of the building permits materials to be brought into the shop without entering the processing area. It can also be used in an emergency. The hot-water heater is located in the shop to minimize the distance to hot-water outlets.

Provisions for Expansion.--The capacity of the plant can be expanded by making minimum changes in the facility and with least interruption of the on-going operation. However, output would likely be increased first by adding a second shift of workers. Cooler space for ungraded eggs could be enlarged by using half of the adjacent shipping cooler. The remaining half of the cooler would continue to be used for graded eggs. A second cooler for graded eggs could be constructed adjacent to the present one by utilizing some of the packaging material storage area.

Space for a second egg grading and packing machine could be provided by moving back the wall separating the packaging material storage area from the processing area. The end wall of the building would be moved outward to compensate for the space taken from the packaging material area.

An alternative expansion plan would enlarge the graded egg cooler, processing, and packaging material areas as previously suggested but not the ungraded egg cooler. When the quantity of eggs handled exceeded the capacity of the cooler, the excess eggs could be held in coolers on the production farms and transported to the plant as space became available.

Firm B

Background

An egg packing firm purchased a large preengineered steel building previously used for a warehouse that contained three refrigerated coolers. The new owners decided to convert the building to a shell egg packing plant with capacity initially to handle 120 cases of eggs per hour and with expansion provisions for a future output of 240 cases per hour by adding a second grading machine. Ultimately the firm intends to add an egg products operation housed adjacent to the shell egg packing facility.

The building is located within an urban area where the proposed centralized egg packing operation would serve production complexes there. A part of the production to be handled is owned by the firm.

Initially, eggs will be handled from approximately 815,000 birds, which are expected to more than double in 5 years to 1,750,000 birds.

Facility Requirements

If an average annual production rate of 65 percent is assumed, then approximately 10,300 cases of eggs would presently be produced weekly and would reach 22,118 cases in 5 years if the anticipated flock increase occurs. Eggs will be received at the plant on castered racks holding 15 cases each (450 doz) and held in a receiving cooler until they are moved to the processing area for grading and packing.

Since the plant will operate 5 days per week, it will have to handle approximately 2,060 cases daily to compensate for the weekend when no processing will occur. In 5 years, the expected daily volume of eggs processed will increase to 4,423 cases. The estimated allowance is 1 percent for loss and 6 percent for undergrades so that the net weekly output for graded eggs will be 9,580 cases and 20,570 in 5 years.

Storage or receiving cooler space would be needed for temporarily holding 2,060 cases of incoming ungraded eggs on 137 racks, assuming a 1-day turnover (table 2). In 5 years, approximately 210 racks would be needed. After the eggs are graded and packed, space would be needed for storing them on 192 pallets holding 30 cases each for an average inventory of 5,748 cases, assuming a 3-day turnover. If 10 percent more pallets are arbitrarily added to allow for partially filled ones, space would be needed for 194. An additional 21 pallets would be required for holding undergrades, assuming a 7-day turnover. In 5 years, space would be needed for approximately 11,601 cases of graded eggs requiring 387 pallets. Undergrades amounting to 41 pallet loads could also be

Table 2.--Storage space requirements

Item	Units	Handling equipment	Handling units	Space per handling unit	Total floor-space ^{1/}
	<u>Number</u>		<u>Number</u>	<u>Ft²</u>	<u>Ft²</u>
Cooler:					
Eggs (cases):					
Ungraded-----	2,060	Racks---	137	6	822
Graded-----	5,748	Pallets-	192	15.2	2,918
Undergrades-----	615	--do----	21	15.2	319
Dry storage:					
Packaging material					
(bundles): ^{2/}					
Cartons-----	1,345	--do----	90	15.2	1,368
Cases-----	931	--do----	47	15.2	714
Filler-flats-----	729	--do----	52	15.2	790

^{1/} Does not include aisle space.

^{2/} Average minimum inventory plus quantity received per shipment.

held in the shipping cooler if identified adequately; however, if there is any likelihood of their becoming intermingled with graded eggs, they should be stored in the receiving cooler.

Description of Proposed Plant

Building.--The preengineered steel building consists of two adjoining units with a common load-bearing wall between them and a double-pitched roof. Overall dimensions of the building are 200 by 144 feet. The floor of the plant and the platform extending along one side of the structure are at one level. Two coolers also were available from previous occupancy.

On the second floor is a business office and employee facilities, consisting of a lunchroom and restrooms. Access to this area is by an inside stairway.

Plant Layout.--The receiving and shipping platform, 167 by 20 feet, extends along one side of the plant (fig. 3). It provides access to the receiving cooler, two shipping coolers, and the package material storage area. The platform is enclosed and an office is at one end. Although the platform as originally constructed was open at the front, it should preferably be enclosed so that escaping refrigerated air can be used when the cooler doors are opened and product quality can be maintained during truck loading operations.

Ungraded eggs are received at the platform on castered metal racks transported on trucks to the plant. The racks, 3 by 2 feet, with 5 shelves holding 450 dozen eggs on filler-flats, are moved manually from the trucks onto the platform and then to the receiving cooler. The platform is also used for loading trucks with graded eggs and for receiving packaging material, which is unloaded onto pallets and moved to dry storage with a forklift truck.

The storage area consists of refrigerated (coolers) and nonrefrigerated space. The space for storing eggs and packaging material is consistent with the requirements in table 2.

A receiving cooler is provided for holding ungraded eggs and a shipping cooler for storing them after they have been graded and packed.

The receiving cooler is 69 by 42 feet with a 10-foot-high ceiling. It has space for 267 castered racks holding 15 cases each for a total cooler capacity of 4,005 cases of eggs. Although the cooler is larger than needed initially, it provides sufficient capacity for the anticipated increased production in 5 years. By using the aisle for temporary storage, the needs for an additional year can also be met. The aisle is approximately 8 feet wide, but this will vary depending on how closely the racks are positioned. The L-shaped cooler provides access to both the platform and the processing area. Sliding insulated doors are preferred to swinging doors that open into the working area and may cause some congestion.

One of the shipping coolers is 56 by 42 feet. It provides storage space for 3,360 cases of eggs placed on 112 pallets, each of which is 4 by 3 feet. By double stacking pallets as the firm plans to do, the capacity could be increased to 6,720 cases. However, the effective capacity is less because some pallets are likely to be only partially loaded because of different brands and

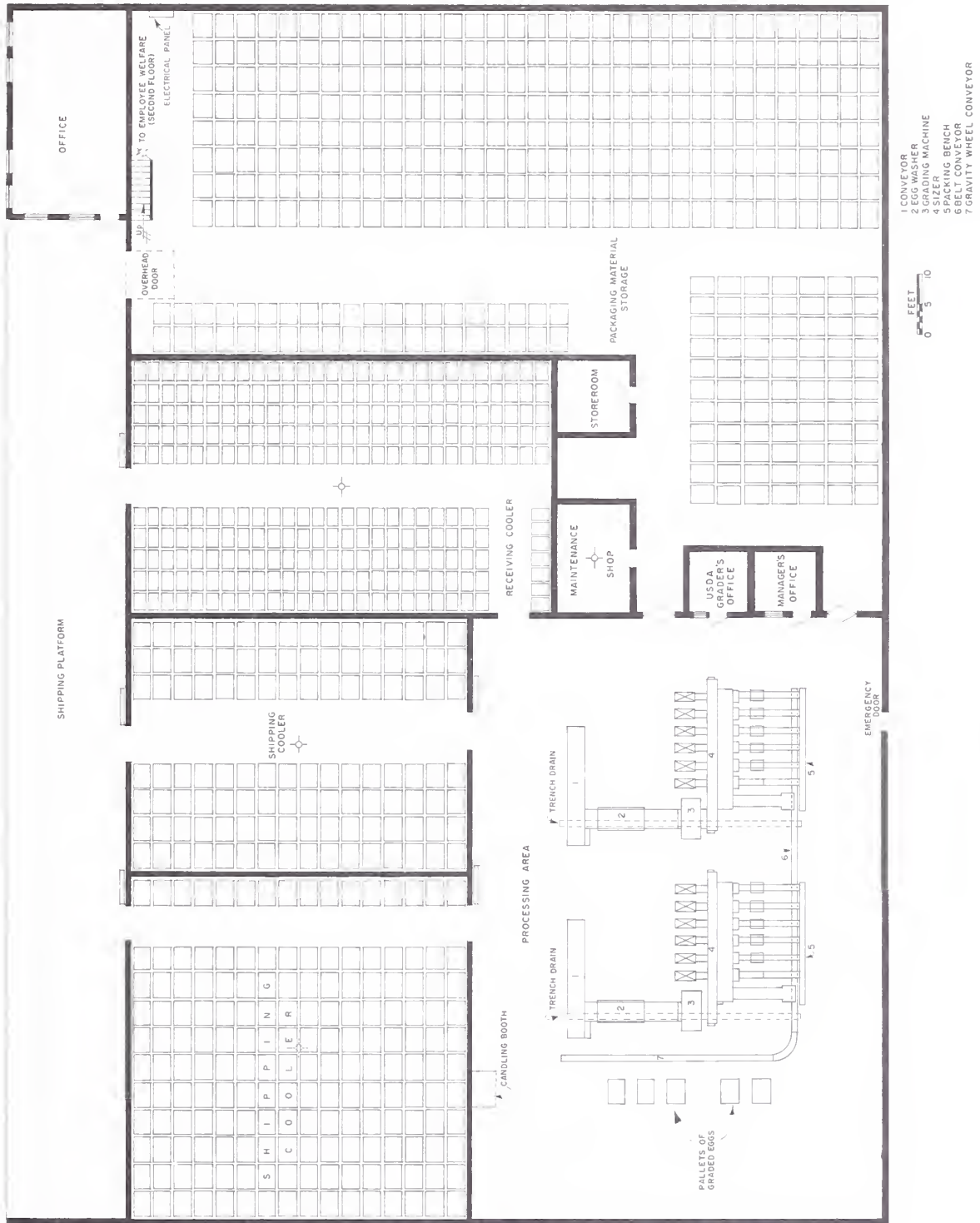

Figure 3.--Layout for firm B.

sizes of eggs that are packed. An aisle approximately 10 feet wide extends straight through the cooler from the processing area to the platform. Sliding cooler doors are also provided.

The second shipping cooler is 57 by 56 feet and provides storage space for 176 pallets with a capacity for 5,280 cases. By stacking pallets 2 high, which is the intention of the firm, a total of 10,560 cases could be stored at 100 percent capacity. This quantity is not realistic, however, since some of the pallets would unlikely be fully loaded. By stacking pallets two high, there is danger of damaging the shells of some of the eggs. A straight-through aisle, approximately 8 feet wide, provides access from the processing area to the shipping platform.

Storage for packaging materials uses approximately 8,893 square feet of floorspace. This is an L-shaped area with the main part extending from the shipping and receiving platform to the opposite side of the building; it adjoins the processing area. Space is provided for approximately 381 pallets of packaging material depending on the arrangement. By double stacking, 762 pallets can be placed in the space provided, or if placed 3 high, 1,143 pallets can be stored.

Initially the firm plans to install one grading machine with a capacity of 120 cases per hour. It is positioned approximately 10 feet from the wall separating the processing and packaging material storage areas. The conveyor (1) that feeds eggs to the washer (2) is positioned approximately 15 feet from the coolers. The packing bench (5) at the opposite side of the machine is approximately 12 feet from the outside wall of the building.

A trench floor drain, 12 inches wide, 8 inches or more deep, and approximately 40 feet long, is located parallel to the egg washer. The washer is positioned over the trench so that discharged water flows directly into it rather than onto the floor. A similar drain provides for a second machine if it is installed later. Each trench has a 4-inch drain with a deep seal trap, and the bottom of the trench slopes to the drain outlet.

Racks of eggs are moved manually from the receiving cooler to the processing area, where the eggs are placed on a conveyor that transports them to the conveyor of the washer. Ideally a small electric or hydraulic lift should be used to position the racks at variable heights and thus removing the eggs from the lower shelves is easier for a worker.

After cases are filled with cartoned eggs, they are pushed manually onto the belt conveyor (6) back of the packing bench and to a gravity wheel conveyor (7), which serves as a temporary accumulation area. They are then palletized and transported to the graded egg coolers. The undergrade eggs would be cased, palletized, and then held in the shipping cooler. Inedible eggs would be handled according to provisions of the Egg Products Inspection Act (1970).

Bundled cartons are transported on pallets from the package material storage area and positioned near the packing section of the grading machine. Similarly, pallets of empty cases are positioned near the packing bench within easy reach of the case packers. An alternative is to transport the empty cases from storage to the packing area on an overhead monorail conveyor with suspended L hooks that

hold individual cases. The conveyor passes above the case packing stations and returns to storage, where the empty hooks are reloaded with cases.

A candling booth (fig. 2) near the door of the larger graded egg coolers (fig. 3) is necessary to monitor product quality. Eggs should be randomly candled after grading and packing and also later after they have been stored in the cooler for a short time to detect both thermal- and impact-caused shell cracks.

A door in the outside wall of the processing area can be used by workers in an emergency.

An auxiliary area includes offices, employee facilities, storeroom, and a maintenance shop.

An office, 34 by 19 feet, is at the end of the receiving-shipping platform adjacent to the packaging material storage area. Another business office is on the second floor with access by an inside stairway. A small office, 10 by 10 feet, is provided for the USDA grader with the entrance from the processing area. Ideally a window should be installed to overlook the processing operations from within the office. Another office, 10 by 10 feet, with a window overlooking the operation is for the plant manager.

Provisions for Expansion.--In 3 years, if the anticipated production develops, the processing facilities will have to be expanded by adding a second 120-case-per-hour grading machine. Before the second machine could be economically utilized, adding a second shift of workers might be preferable to more fully use the existing machine.

The second machine would be positioned to the left of the first one. The belt conveyors adjacent to the packing benches would be aligned so that cases of eggs would be moved from the first machine onto the conveyor of the second. All the eggs would thus be accumulated on one storage conveyor to await palletizing. The second machine would be located over the trench floor drain similarly to the first machine.

The firm plans to develop facilities for an egg products operation in conjunction with shell egg packing. Since an egg products operation must comply with stringent Federal regulations, it is advisable to develop an efficient egg packing operation without compromising the layout to make it adaptable to include egg products, because the latter would likely necessitate adding an adjoining building. Only the packaging material storage area and possibly the receiving cooler could be jointly utilized by the shell egg packing and the egg products operations.

Firm C

Background

The shell egg firm now operates an antiquated, inefficient packing plant that no longer has sufficient processing capacity. Neither is it centrally located to the production area it serves and therefore assembly costs are excessively high. Consequently, the firm has decided to construct a new plant

at another location. The site chosen consists of 4 acres of land purchased adjacent to an interstate highway with access to a State highway.

Eggs are processed from flocks in the local area, with some of the birds owned by the firm and others contracted. Some of the eggs are received and stored temporarily without grading or packing for sale later as "nest run."

Initially the firm plans to build a cooler with sufficient capacity to hold the nest run eggs. Later the remainder of the plant would be built encompassing the cooler, which will then be used to hold both nest run eggs and those to be graded and packed.

Eggs are presently transported from the production farms to the plant on castered racks holding 25 cases on filler-flats, and this method of transporting will be continued in the proposed new plant.

Facility Requirements

The firm is handling the production from 350,000 hens, which are expected to increase to 600,000 in 5 years. Assuming an average annual production rate of 70 percent suggested by the firm, approximately 4,763 cases of eggs produced weekly would increase to 8,166 in 5 years.

The average daily inventory of incoming ungraded eggs to the plant is now 952 cases, which would require cooler space for 38 racks, each holding 25 cases of eggs. In 5 years, twice as much cooler space would be needed. Since the firm also requires space for nest run eggs handled without processing, the firm's receiving cooler with a total capacity for 3,000 cases of eggs stored on 120 racks would be adequate for the volume handled in the next 5 years (table 3).

The net quantity of graded eggs packed daily is 886 cases with 60 percent of them cartoned and 40 percent packed on filler-flats. Of those cartoned, 65 percent are put in fiber cases and 35 percent in 15-dozen-capacity wire baskets. With a 3-day turnover rate, the shipping cooler must provide storage space for approximately 2,658 cases of graded eggs and 286 cases of undergrades, the latter having a turnover of 5 days. This would require 97 pallets with an arbitrary allowance of 10 percent space made for partially filled pallets because of different brands and sizes of eggs and 9.5 pallets for undergrades. In 5 years, shipping cooler space would likely be needed for 167 pallets of graded eggs and 16.3 pallets of undergrades.

Approximately 3.6 pallets of cartons, 1.6 pallets of cases, and 1.2 pallets of filler-flats would be used daily for the present volume of eggs. Since the plant desires to maintain a 3-week inventory of packaging material, storage space would be needed for 139 pallet loads. This would include 20 pallets for storing an estimated 1,000 wire baskets, which would be held for a short time until reused. In 5 years, dry storage space would be needed for 236 pallets of packaging material.

The firm plans to initially use its existing 70-case-per-hour grading and sizing machine, and when more capacity is required, to replace it with a larger machine that could handle approximately twice as many eggs per hour.

Table 3.--Storage space requirements

Item	Units	Handling equipment	Handling units	Space per handling unit	Total floor-space _{1/}
	<u>Number</u>		<u>Number</u>	<u>Ft²</u>	<u>Ft²</u>
Cooler:					
Eggs (cases): <u>2/</u>					
Ungraded-----	<u>3/</u> 3,000	Racks-----	120	13.7	1,644
Graded-----	<u>4/</u> 2,658	Pallets---	<u>5/</u> 298.6	15.2	1,489
Undergrades----	<u>6/</u> 285	--do-----	10	15.2	152
Dry storage:					
Package material:					
Cartons (bundles)	<u>7/</u> 999.2	--do-----	62	15.2	942
Cases (bundles)	<u>7/</u> 491	--do-----	35	15.2	532
Filler-flats					
(bundles)----	<u>7/</u> 441	--do-----	22	15.2	334
Wire baskets					
(number)-----	<u>8/</u> 1,000	--do-----	20	15.2	304

1/ Does not include aisle space.

2/ 30-doz case or equivalent.

3/ Includes nest run eggs.

4/ 3-day turnover.

5/ Includes 10 percent allowance for partially filled pallets.

6/ 5-day turnover.

7/ 3-week average inventory.

8/ Average inventory.

Presently a small volume of special egg products is produced that requires a separate cooler and processing area. Shell eggs and packaging material for this special function will be transported from other plant storage areas as needed.

The firm also needs four offices for company personnel who do not have specific plant management responsibilities.

Description of Proposed Plant

Building.--The building is a preengineered steel structure, 160 by 110 feet, with a double-pitched roof. Since the site slopes, some earth has to be moved to create a level area for constructing the building. The low side of the slope provides for a truck-bed height platform. The entrance to the site dictates that offices be on the upper side of the slope at ground level so that the platform can be on the lower level.

Initially, only the receiving cooler will be constructed to take care of immediate needs; later it will be incorporated into a completed facility.

Plant Layout.--The receiving and shipping area consists of a platform 14 feet wide and 85 feet long (fig. 4). It is approximately 46 inches above ground level on the downward side of the building. Steps at one end of the platform are for worker access. The platform is enclosed and contains three overhead doors, 8 by 8 feet, to facilitate truck loading and unloading. The enclosure contains the refrigerated air from the coolers when the doors are opened during loading and unloading.

Ungraded eggs are received on castered metal racks, 5 by 2 feet, that hold 25 cases (750 doz) of eggs each. The loaded racks are removed from the trucks onto the platform and taken to the receiving cooler. Graded eggs are loaded onto trucks from this same platform.

An alternative is to eliminate the platform and perform the loading and unloading functions by positioning the trucks directly at the doors of the coolers and packaging material storage area. However, this eliminates the platform area for temporarily storing empty racks and pallets.

The storage area consists of refrigerated coolers for eggs and nonrefrigerated space for packaging materials.

The receiving cooler provides refrigerated space for holding incoming eggs to be graded and the shipping cooler for graded eggs awaiting shipment.

The receiving cooler for ungraded eggs is 50 by 48 feet with a 10-foot-high ceiling. It provides space for 3,175 cases of eggs on 127 racks, each of which is 5 by 2 feet and holds 25 cases. They are positioned in rows on each side of an 8-foot-wide L-shaped aisle, which can also be utilized for temporary storage if necessary.

The graded egg shipping cooler, which is 53 by 47 feet with a capacity for 130 pallets holding 30 cases each, provides space to store 3,900 cases. Realistically, however, the effective storage capacity is less because of partially filled pallets resulting from different brands and sizes of eggs that are packed. Additional temporary storage space is available by utilizing the 8-foot-wide aisle.

Each cooler has a 4-inch floor drain with a deep seal trap to help maintain sanitation. By sloping the floor one-eighth inch per foot to the drain, the floors can be washed periodically. Each cooler should have a curb constructed at the junction of the floor and wall.

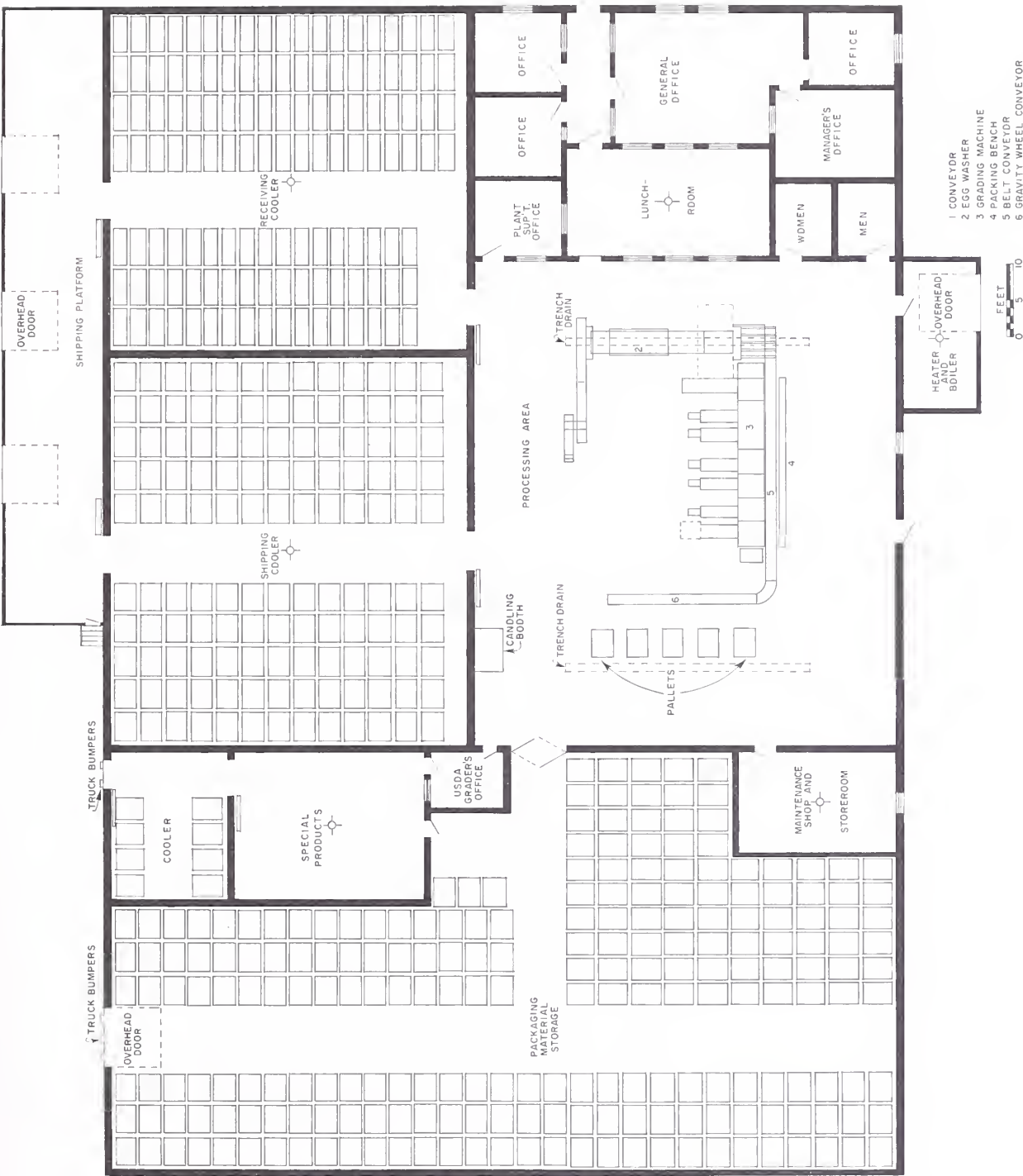

Figure 4.--Layout for firm C.

The space provided in both the receiving and the shipping coolers is a compromise between the amount needed presently and the amount anticipated in 5 years. When necessary, coolers on the production farms can be used to supplement the plant's receiving cooler. More effective use of the shipping cooler can be made by increasing the turnover rate of eggs and by storing undergrades in the receiving cooler instead of the shipping cooler as proposed.

The receiving and shipping coolers adjoin so that a U-shaped product flow exists to and from the processing area.

Packaging material is unloaded from trucks at the platform that also serves the coolers. Pallet loads of materials are transported to the L-shaped storage area, which contains 4,752 square feet of floorspace sufficient for holding 221 pallets. Because of the flammability of the packaging material and the likely effect on fire insurance rates, the wall separating the storage area from adjacent plant areas should be constructed of fireproof material. An overhead sprinkling system is also essential.

Packaging material can be stored two pallets high to double the storage capacity by utilizing cubic space; however, a forklift truck would be required. If necessary, pallet loads of material could also be stored temporarily in the aisles. The average quantity of packaging material maintained by the firm is an arbitrary management decision that will determine the amount of storage space needed.

The processing area is 66 by 58 feet. The egg washer (2) and grading machine (3) are positioned to permit an efficient flow pattern for both the eggs and the packaging materials. Palletized bundles of cartons, cases, filler-flats, and wire baskets are moved from the storage area to the processing area as needed.

A trench floor drain beneath the washer and grader removes the overflow water from the washer that is channeled directly into it and the water used in the cleanup operations. A second drain serves the other side of the area.

The eggs are moved manually on racks from the receiving cooler to the processing area, where they are washed, graded, sized, and packed (2-4), and then they are transported to the shipping cooler. The empty racks are returned to the platform and held temporarily until taken to the farms for reloading.

The undergrade eggs are held on racks in the receiving cooler. Inedible eggs are handled according to provisions of the Egg Products Inspection Act (1970).

A candling booth (fig. 2) near the shipping cooler (fig. 4) is used to spot check the quality of the eggs as they come from the packing line. It is also used later to recheck quality after the eggs have been held in the shipping cooler for sufficient time to cool.

Trash from the grading and packing operations is emptied into a portable storage receptacle near the receiving and shipping platform. Periodically it is emptied into a truck and the trash hauled away by the firm or a disposal company.

An area, 42 by 20 feet, is provided to process specialized egg products. Since the output is expected to remain small, both eggs and packaging material are transported as needed through the packaging material storage area. The special products are stored in a small cooler, 20 by 16 feet. Trucks are positioned directly at the door for loading. The small volume produced does not justify extending the platform to serve the cooler.

The auxiliary area consists of approximately 2,469 square feet of floor-space, which includes employee facilities, offices, and a maintenance shop.

A general office for clerical employees is 26 by 18 feet. The manager's office is 16 by 12 feet. An office for the plant superintendent is 12 by 10 feet and contains a window overlooking the packing operations. Three additional offices, each 12 by 11 feet, are for employees not directly involved with the plant operations. A 10- by 8-foot office provided for the USDA grader has a window and a door with glass panes so he can see both the shell egg packing and special products operations.

The employee lunchroom, which is 28 by 14 feet, has one end that serves as a passageway from the plant entrance hallway to the processing area to fully utilize space. Windows in the sidewalls permit the operations in the processing area to be viewed from the general office.

The women's and men's restrooms, each 10 by 8 feet, are mechanically ventilated to the outside and have self-closing doors. The necessary number of sanitary facilities is given in the guidelines prescribed by the U.S. Department of Agriculture regulations governing the inspection of eggs and egg products.^{7/}

The shop area, 21 by 14 feet, provides storage for tools and spare parts essential for maintenance and for supplies.

The boiler and heating system is housed in a 20- by 10-foot room adjoining the plant next to the processing area to restrict the heat from entering the processing facility and as a safety measure.

Provisions for Expansion.--The capacity of the plant can be expanded by making minimum changes to the facility and without interrupting the ongoing operations.

Cooler space for ungraded eggs can be supplemented by on-the-farm coolers to avoid expanding the plant cooler. By merging the specialized product area into the graded egg cooler, 840 square feet can be added. The grading and packing output can be increased by installing a grading machine with twice the capacity of the existing one. No alteration of the area would be necessary to accommodate it. An alternative is to install a second machine with the same capacity as the existing one. This would necessitate relocating the wall now

^{7/} See footnote 6, p. 8.

separating the processing and packaging material storage area to create adequate space for the second machine.

New standardized 20-foot-wide building sections would be added to the end of the building to replace packaging material storage space taken by the second grading machine. The shop and USDA grader's office, as well as the special products processing area, would have to be relocated in the new addition.

BENEFITS PROVIDED BY THE LAYOUTS

The layouts provide the following benefits to the three firms in this study:

- Needs of individual firms served.
- Adequate space for each operation.
- No wasted space.
- Provision for future expansion at minimum cost and least disruption to operation.
- Provision for safety and welfare of employees.
- Adequate space for office functions.
- Straight flow of product that eliminates backtracking.
- Ease of maintaining sanitation.
- Adequate refrigerated space for maintaining product quality.
- Provision for using modern materials-handling equipment.
- All operations confined to one building.
- Adequate loading and unloading platforms that enclose and protect product from climatic conditions.

APPENDIX

Data Collection Form

I. Production information

1. What is total number of birds from which eggs will be processed? _____
2. What is average number of eggs (doz) produced daily? _____
3. What is average annual lay (i.e., 60 or 65 percent, etc.)? _____
4. What is projected flock size from which eggs will be processed?

<u>Year</u>	<u>Birds (number)</u>
19__	_____
19__	_____
19__	_____
19__	_____
19__	_____

II. Incoming ungraded eggs

1. How frequently are eggs received at plant (i.e., daily, every 2 days, etc.)? _____
What quantity (30-doz cases) is received daily? _____
2. Are eggs received in 30-doz cases / /, on filler-flats / /, on pallets / /, on filler-flats on castered racks / /, or other (describe)? _____

3. Are they stored in receiving coolers on racks / /, pallets / /, or semilive skids / /?
What are dimensions (such as 3 by 4 ft) of pallets _____, racks _____, and skids _____?
4. What is average daily inventory (30-doz cases) of ungraded eggs?

5. What is average turnover for ungraded eggs (i.e., 1 or 2 days)? _____
6. Is production on Saturday, Sunday, and holidays held at plant or in coolers on farm? _____
7. Do you have holding coolers on production farms that supplement holding capacity at plant? _____

III. Processing

1. How many grading machines are now in use? _____
2. What is make _____, model _____, and rate capacity (cases/h) _____?
3. What is average percentage of machine capacity utilized? _____
4. If eggs are received from farms in cases, are empties returned to farm /_/ or used to pack cartoned eggs /_/?
5. Are ungraded eggs moved from cooler to washer on racks /_/ , pallets /_/ , semilive skids /_/ , or conveyor /_/?
6. Are graded eggs moved to shipping cooler from cartoning station on pallets /_/ or directly by gravity wheel conveyors /_/?
7. What is approximate number of brands packed? _____
8. What is average turnover rate (days) of graded eggs? _____
9. What is average inventory of graded eggs? _____
10. What is size of pallets on which graded eggs are stored? _____
11. What percentage of graded eggs is cartoned _____, loose _____, in 30-dozen cases _____, or in wire baskets (15 doz) _____?
12. What percentage of eggs received is loss in grading operation _____ or percentage of undergrades _____?
13. Are undergrades (for breaking stock) stored in graded egg cooler? _____
 How often are they shipped? _____
 What quantity is usually shipped at one time? _____
 If not stored in shipping cooler, where are they accumulated? _____

IV. Packaging material

1. Is packaging material stored on pallets /_/ or stacked on floor /_/?

What is size of pallets? _____

2. What is minimum inventory of each kind of material at time new delivery is received?

Cases (bundles) _____

Cartons (bundles) _____

Filler-flats (bundles) _____

Wire baskets (number) _____

3. How many units per bundle?

Cases _____

Cartons _____

Filler-flats _____

4. How many bundles per pallet in storage?

Cases _____

Cartons _____

Filler-flats _____

5. How many bundles are received per load for—

Cases _____ by truck / /, rail / /?

Cartons _____ by truck / /, rail / /?

Filler-flats _____ by truck / /, rail / /?

6. How often is a load of packaging material received per week _____
or per month _____?

From what distance (miles) does it come? _____

7. What is elapsed time from date of order until delivery? _____

8. What is average inventory (15 doz) of wire baskets? _____

9. Transport equipment within plant:

How many manual pallet transporters? _____

How many powered pallet transporters? _____

How many semilive skid jacks? _____

How many forklift trucks? _____

How many roller or wheel gravity conveyors? _____

VI. Future needs

1. Will existing grading machine(s) continue to be used? _____

2. What kind and capacity of machines will be installed as replacements or additions? _____

3. What is rated capacity of new machines? _____

4. Do you propose to use a second shift to handle anticipated future volume? _____

VII. What are duties, number of employees now used or else anticipated, and time for each duty?

Duties

Employees (number)

Time for each
duty (percent)

Analysis of Firm A Facility Needs

Table 4.--Projected egg production volume

Year	Birds	Egg production ^{1/}	
		Daily	Weekly
	<u>Thousands</u>	<u>Cases</u>	<u>Cases</u>
1978-----	300	542	3,794
1979-----	350	632	4,424
1980-----	400	722	5,054
1981-----	450	812	5,684
1982-----	500	903	6,321

^{1/} 65 percent rate of lay assumed.

Table 5.--Estimated volume of loss and undergrade eggs

Year	Weekly production	Loss (1 percent)	Undergrades (5.5 percent)	Total loss and undergrades	Net graded
	<u>Cases</u>	<u>Cases</u>	<u>Cases</u>	<u>Cases</u>	<u>Cases</u>
1978-----	3,794	38	209	247	3,547
1979-----	4,424	44	243	287	4,137
1980-----	5,054	51	278	329	4,725
1981-----	5,684	57	313	370	5,314
1982-----	6,321	63	348	411	5,910

Table 6.--Volume of graded eggs packaged

Year	Weekly production	Undergrades and breaking stock	Cartoned <u>1/</u>	Loose pack <u>2/</u>	Total packaged
	<u>Cases</u>	<u>Cases</u>	<u>Cases</u>	<u>Cases</u>	<u>Cases</u>
1978-----	3,794	209	3,015	532	3,547
1979-----	4,424	243	3,516	621	4,137
1980-----	5,054	278	4,016	709	4,725
1981-----	5,684	313	4,517	797	5,314
1982-----	6,321	348	5,023	887	5,910

1/ 85 percent of graded eggs.

2/ 15 percent of graded eggs placed on filler-flats and in cases.

Table 7.--Quantity of incoming ungraded eggs stored and racks

Year	Weekly production	Average inventory <u>1/</u>	Racks
	<u>Cases</u>	<u>Cases</u>	<u>Number</u>
1978-----	3,794	1,200	80
1979-----	4,424	1,400	94
1980-----	5,054	1,600	107
1981-----	5,684	1,800	120
1982-----	6,321	2,000	134

1/ Linear projection.

Table 8.—Quantity of graded eggs stored and pallets

Year	Weekly production	Average inventory <u>1/</u>	Pallets <u>2/</u>	10 percent allowance
	<u>Cases</u>	<u>Cases</u>	<u>Number</u>	<u>Number</u>
1978 -----	3,547	1,267	43	48
1979 -----	4,137	1,478	50	55
1980 -----	4,725	1,688	57	63
1981 -----	5,314	1,898	64	71
1982 -----	5,910	2,111	71	79

1/ $2\frac{1}{2}$ -day turnover = $\frac{7}{2.5} = 2.8$ factor.

2/ 3- by 4-ft pallets.

Table 9.—Volume of undergrade eggs stored and pallets 1/

Year	Quantity	Pallets
	<u>Number</u>	<u>Number</u>
1978 -----	209	7
1979 -----	243	9
1980 -----	278	10
1981 -----	313	11
1982 -----	348	12

1/ 7-day turnover.

Table 10.—Total volume of eggs stored in shipping cooler and pallets

Year	Graded	Undergrades	Total	Pallets needed	Total pallets <u>1/</u>
	<u>Cases</u>	<u>Cases</u>	<u>Cases</u>	<u>Number</u>	<u>Number</u>
1978 -----	1,267	209	1,476	50	55
1979 -----	1,478	243	1,721	58	64
1980 -----	1,688	278	1,966	66	73
1981 -----	1,898	313	2,211	74	82
1982 -----	2,111	348	2,459	82	91

1/ 10-percent allowance for partially loaded pallets.

Table 11.—Carton usage per week

Year	Eggs cartoned	Cartons		
		Units <u>1/</u>	Bundles <u>2/</u>	Pallets <u>3/</u>
	<u>Cases</u>	<u>Number</u>	<u>Number</u>	<u>Number</u>
1978 -----	3,015	90,450	452.2	29
1979 -----	3,516	105,480	527.4	33
1980 -----	4,016	120,480	602.4	38
1981 -----	4,517	135,510	677.5	43
1982 -----	5,023	150,690	753.4	47

1/ 30 cartons needed per case of eggs.

2/ 200 cartons per bundle.

3/ 16 bundles per pallet.

Table 12.—Case usage per week

Year	Cases		
	Units	Bundles <u>1/</u>	Pallets <u>2/</u>
	<u>Number</u>	<u>Number</u>	<u>Number</u>
1978 -----	3,547	177.4	13
1979 -----	4,137	206.8	15
1980 -----	4,725	236.2	17
1981 -----	5,314	265.7	19
1982 -----	5,910	295.5	22

1/ 20 cases per bundle.

2/ 14 bundles per pallet.

Table 13.—Filler-flat usage per week

Year	Eggs <u>1/</u>	Filler-flats		
		Units <u>2/</u>	Bundles <u>3/</u>	Pallets <u>4/</u>
	<u>Cases</u>	<u>Number</u>	<u>Number</u>	<u>Number</u>
1978 -----	741	10,374	74.1	4
1979 -----	864	12,096	86.4	5
1980 -----	987	13,818	98.7	5
1981 -----	1,110	15,540	111.0	6
1982 -----	1,235	17,290	123.5	7

1/ Loose pack plus breaking stock (table 6).

2/ 14 units used per case.

3/ 140 units per bundle.

4/ 20 bundles per pallet.

Table 14.--Total inventory requirements for packaging material and amount per delivery

Item	Minimum inventory ^{1/}		Amount per delivery	
	Bundles	Pallets	Bundles	Pallets
	<u>Number</u>	<u>Number</u>	<u>Number</u>	<u>Number</u>
Cartons -----	3,600	225	900	57
Cases -----	300	22	300	22
Filler-flats --	<u>1,500</u>	75	750	38
Total ----	-----	322	---	117

^{1/} Average inventory at time shipment received.

**U.S. DEPARTMENT OF AGRICULTURE
SCIENCE AND EDUCATION ADMINISTRATION
WASHINGTON, D.C. 20250**

**OFFICIAL BUSINESS
PENALTY FOR PRIVATE USE, \$300**

**POSTAGE AND FEES PAID
U. S. DEPARTMENT OF
AGRICULTURE
AGR 101**

