



AgEcon SEARCH

RESEARCH IN AGRICULTURAL & APPLIED ECONOMICS

The World's Largest Open Access Agricultural & Applied Economics Digital Library

This document is discoverable and free to researchers across the globe due to the work of AgEcon Search.

Help ensure our sustainability.

Give to AgEcon Search

AgEcon Search

<http://ageconsearch.umn.edu>

aesearch@umn.edu

*Papers downloaded from **AgEcon Search** may be used for non-commercial purposes and personal study only. No other use, including posting to another Internet site, is permitted without permission from the copyright owner (not AgEcon Search), or as allowed under the provisions of Fair Use, U.S. Copyright Act, Title 17 U.S.C.*

No endorsement of AgEcon Search or its fundraising activities by the author(s) of the following work or their employer(s) is intended or implied.

Historic, archived document

Do not assume content reflects current scientific knowledge, policies, or practices.

LMR

CORE LIST

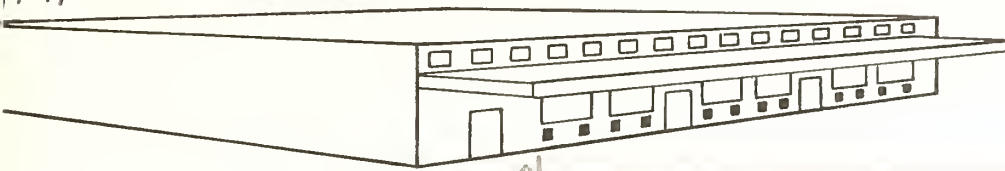

WAREHOUSE LAYOUT AND EQUIPMENT FOR INSTITUTIONAL WHOLESALE GROCERS

IN MULTIPLE-OCCUPANCY BUILDINGS
IN FOOD DISTRIBUTION CENTERS

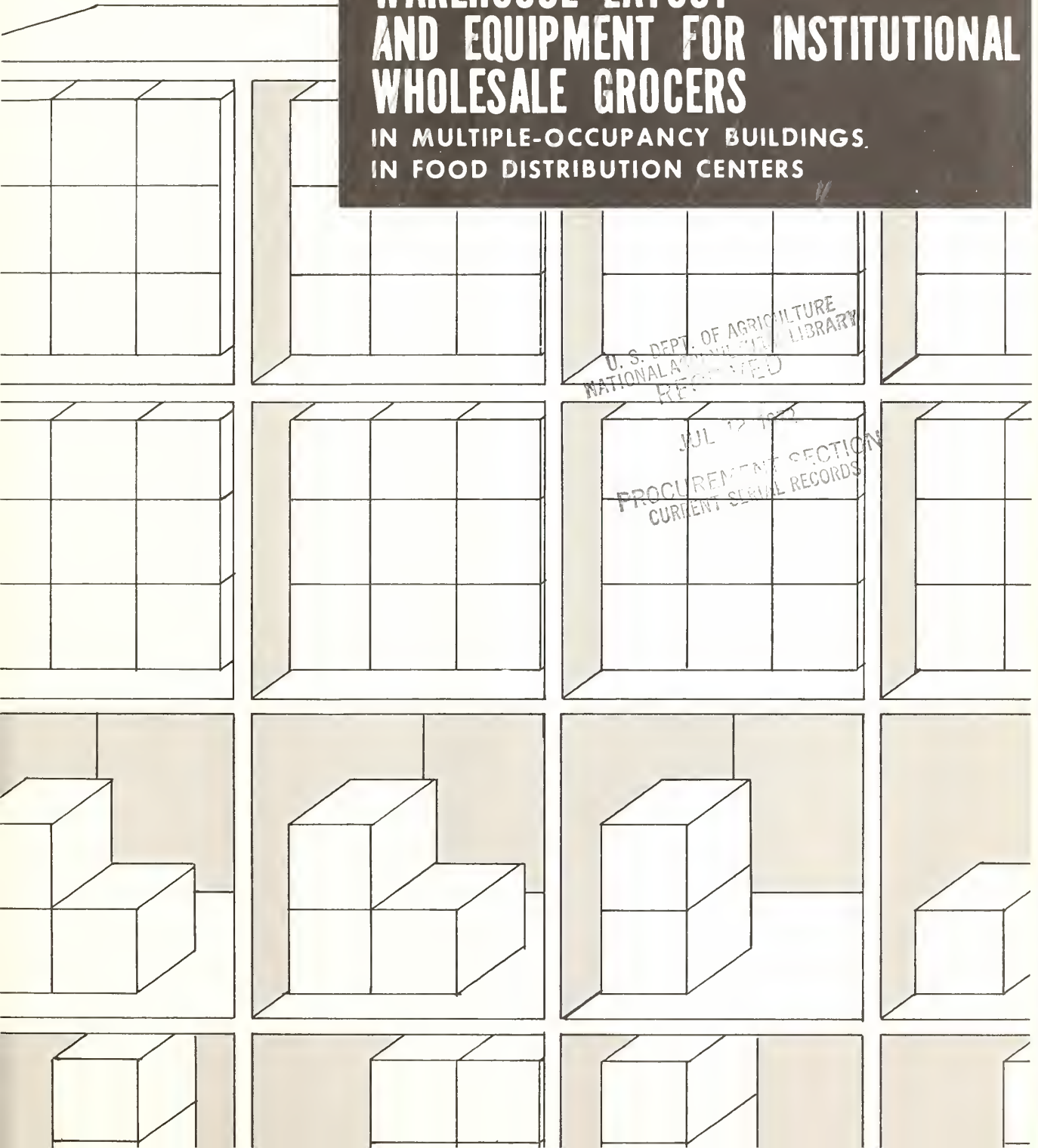

PREFACE

Under the provisions of the Agricultural Marketing Act of 1946, the U.S. Department of Agriculture has maintained an active program of research in the design and utilization of modern food handling facilities. As a result of its research, the Department has recommended construction of wholesale food distribution centers to serve many wholesale food firms in urban areas. Institutional grocery firms represent one kind of firm that has located in such centers.

This report is based on research to aid institutional grocery wholesalers in reducing their warehousing cost through efficient labor practices, layouts, and facilities. The work was conducted under the general supervision of John C. Bouma, investigations leader, Specialized Facility Development, and Kenneth H. Brasfield, chief, Marketing Facilities Development Branch.

Special appreciation is due the various wholesale grocery firms who made their facilities available for detailed study. Research criteria were established by Raymond L. Collins and Philip B. McGill, Research Triangle Institute, under contract with the U.S. Department of Agriculture. The Research Triangle Institute also provided information on the kinds of products handled by small institutional wholesale grocery firms and the parking spaces needed for these wholesalers.

Contents

	Page
Summary	1
Introduction	2
Description of facilities	3
Multiple-occupancy buildings	3
Single-occupancy buildings	4
Handling equipment	5
Forklift trucks	5
Order selection equipment	14
Layout and volume handled	16
Layout	18
Volume handled	27
Volume of business in relation to selection of building	27
Requirements for parking space	28

Warehouse Layout and Equipment for Institutional Wholesale Grocers in Multiple-Occupancy Buildings in Food Distribution Centers

BY JAMES N. MORRIS, JR., *industrial engineer,*
Transportation and Facilities Research Division, Agricultural Research Service

SUMMARY

Two basic types of grocery wholesale facilities are used on urban food distribution centers—multiple-occupancy buildings and single-occupancy buildings. A multiple-occupancy building is comprised of several individual units each measuring 30 by 100 feet. This design allows a grocery wholesaler to use several adjacent units, depending upon the size of his firm. Each unit includes a rail platform, mezzanine, shipping and receiving doors, concrete floor, and high ceiling interior. Several firms would share a multiple-occupancy building. A single-occupancy building, on the other hand, is designed to meet the needs of only one firm.

A wholesaler's layout can be greatly influenced by his choice of forklift trucks for handling equipment. Three types of forklift trucks can be used in a multiple-occupancy building. They are the counterbalanced forklift trucks, which require a 10-foot-wide aisle, and the straddle and the extendable forklift trucks, both of which require a 7½-foot-wide aisle. Firms using counterbalanced forklift trucks will have less floorspace available for storage than those using straddle or extendable forklifts.

Three types of costs associated with using forklift trucks in multiple-occupancy buildings are equipment, labor, and facility. As the greatest use of a forklift truck in institutional grocery warehousing will be in moving incoming products to storage, each cost can be expressed on the basis of a receiving cycle.

The total cost of receiving products in a wholesale grocery multiple-occupancy building differs with the type of forklift. Counterbalanced equipment costs a total of \$1.516 per receiving cycle. The straddle and the extendable forklift trucks are somewhat less expensive

to operate. Straddle forklifts cost approximately \$1.426 per cycle and extendable forklifts, about \$1.446 per cycle. Similarly, total cycle costs will affect the overall operating costs for institutional grocers.

The extendable forklift truck has certain operational advantages over the straddle equipment. As a result of these advantages, many wholesalers may find using extendable forklift trucks more practical even though they are slightly higher in cost than the straddle type.

Moving incoming merchandise to storage is only part of the wholesaling operations that would be carried on in a multiple-occupancy building. Merchandise must also be selected into orders and loaded into delivery trucks. Wholesalers have a choice of several types of selection vehicles. All commonly used equipment would operate efficiently in aisles designed for straddle or extendable forklift trucks.

The layouts of firms in multiple-occupancy buildings share several common features. Sufficient space is available for receiving, checking, and truck-loading operations. Two areas are available for these purposes—one at the front of the unit, under the mezzanine, and one on the rail platform. The area under the mezzanine is also used for stairs to the overhead mezzanine, a first floor restroom, and temporary pallet storage. Sufficient space is available on the mezzanine for offices, restrooms, and if needed, repack rooms.

Four types of storage used by all firms in multiple-occupancy buildings are bulk storage, storage on drive-in pallet racks, storage on conventional pallet racks, and shelf storage of hand-stacked products.

The number of units needed by a wholesaler depends on the size of the firm. A layout for a

two-unit firm in a multiple-occupancy building would be 60 feet wide by 100 feet deep. A repack room would be located under the mezzanine. Conventional pallet racks would be used for storage in the interior of the units. A wholesale facility using three units would measure 90 by 100 feet with a repack room located under the mezzanine. The rack arrangement in the interior of the units would be similar to the design outlined for the two-unit facility. A wholesale facility using four units would measure 120 by 100 feet, and the space under the mezzanine would be used exclusively for receiving and loading out operations. Conventional pallet racks, bulk storage, and shelving would be used for storage in the interior of the four units. Both offices and a repack room would be located on the mezzanine. A wholesale facility using five units would be 150 by 100 feet. The interior of the units would be arranged similarly to that of a four-unit firm. The repack room would be located on the mezzanine.

A firm using two units should be able to handle an annual volume of 3,227 tons of grocery

products, or sales of approximately \$1,290,800. A three-unit firm should be able to handle sales of 4,890 tons or \$1,956,000; a four-unit firm, 6,494 tons or \$2,597,600; and a five-unit firm, 8,156 tons or \$3,262,400.

Wholesalers needing more than 15,000 square feet of warehouse space should not locate in a multiple-occupancy building. Many firms needing this much space are successfully using modern, single-occupancy buildings for their operations.

Wholesalers in multiple-occupancy buildings need parking space for both trucks and cars. Adequate parking for trucks for shipping and receiving operations would be available directly at the front of the facilities. Institutional wholesale grocery firms also need supplementary parking of one space for each unit in the facility. This parking can be located in the center of the 350-foot-wide street between multiple-occupancy buildings. In addition, a two-unit firm should have parking spaces for five cars; a three-unit firm, for six cars; a four-unit firm, for nine cars, and a five-unit firm, for 12 cars.

INTRODUCTION

The costs associated with grocery warehousing have increased rapidly. The average hourly wage of nonsupervisory employees in the wholesale trade, as well as the costs of equipment and construction, has increased substantially in recent years.¹ For example, the average hourly wage of employees in the wholesale food industry increased from \$2.16 an hour to \$2.96 an hour, or 37 percent, from March 1963 to March 1969. Many wholesale grocers by moving into new well-planned warehouses and utilizing modern materials-handling equipment and storage aids have reduced their total handling costs. Some of these wholesalers have located in urban food distribution centers.

The U.S. Department of Agriculture has maintained a research program to develop modern and efficient layouts and methods of opera-

tion to assist grocery wholesalers to minimize their marketing costs. Previous research reports have described how efficient work methods, balanced work crews, better utilization of equipment, and improved layout would increase labor productivity in modern one-story and in multistory warehouses used by a single wholesaler.²

Of the grocery wholesalers locating on food distribution centers, some are too small to need a separate warehouse. These grocers share a building with other wholesalers. Some of the small wholesalers have experienced difficulty

¹ BOUMA, JOHN C. METHODS OF INCREASING PRODUCTIVITY IN MODERN GROCERY WAREHOUSES. U.S. Dept. Agr., Mktg. Res. Rpt. 94, 30 pp. June 1955.

BOUMA, JOHN C., and LUNDQUIST, ARNOLD L. METHODS OF INCREASING LABOR PRODUCTIVITY IN MULTISTORY AND SMALL ONE-FLOOR GROCERY WAREHOUSES. U.S. Dept. Agr., Mktg. Res. Rpt. 142, 42 pp. Nov. 1956

BOUMA, JOHN C., and LUNDQUIST, ARNOLD L. GROCERY WAREHOUSE LAYOUT AND EQUIPMENT FOR MAXIMUM PRODUCTIVITY. U.S. Dept. Agr., Mktg. Res. Rpt. 348, 58 pp. July 1959.

² U.S. DEPARTMENT OF AGRICULTURE, ECONOMIC RESEARCH SERVICE. MARKETING AND TRANSPORTATION SITUATION. U.S. Dept. Agr., Econ. Res. Serv. MTS 153, 39 pp. May 1964; U.S. Dept. Agr., Econ. Res. Serv. MTS 179, 43 pp. Nov. 1970.



R.R. TRACKS

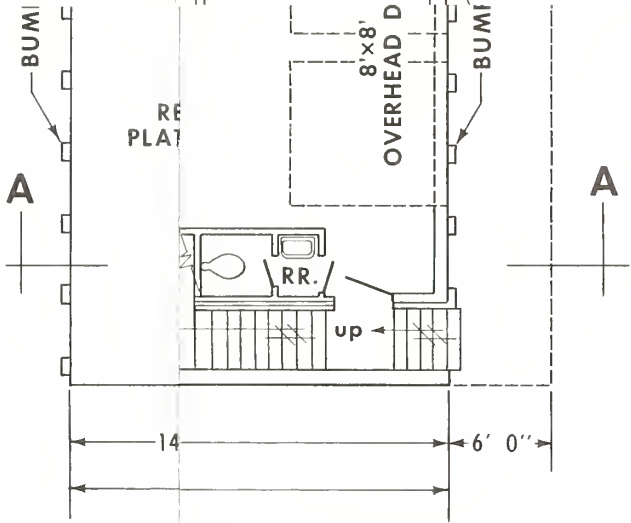
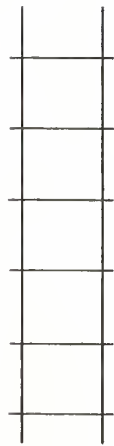

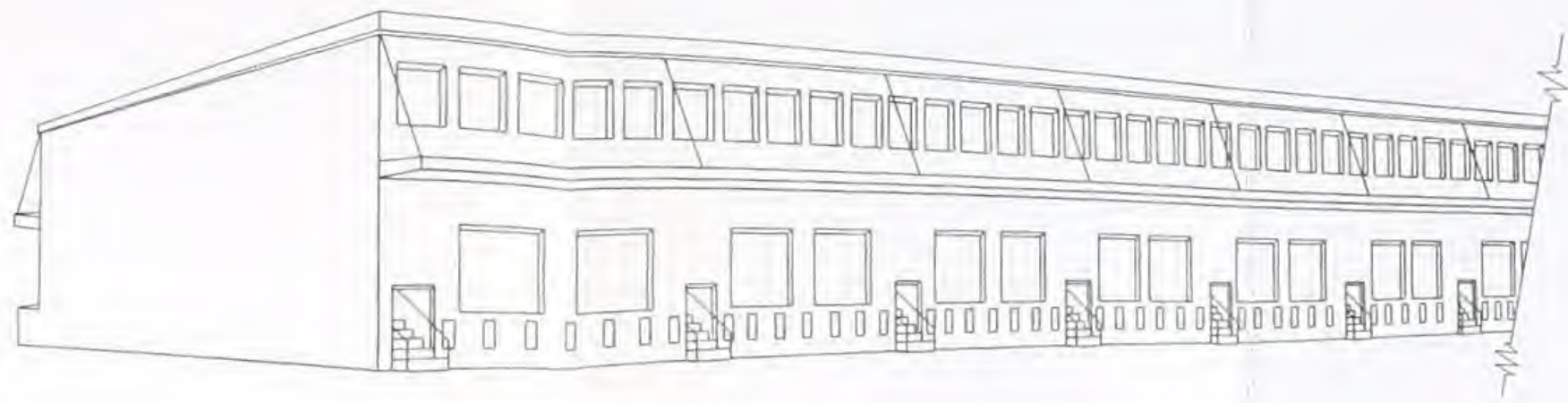

PERSPECTIVE

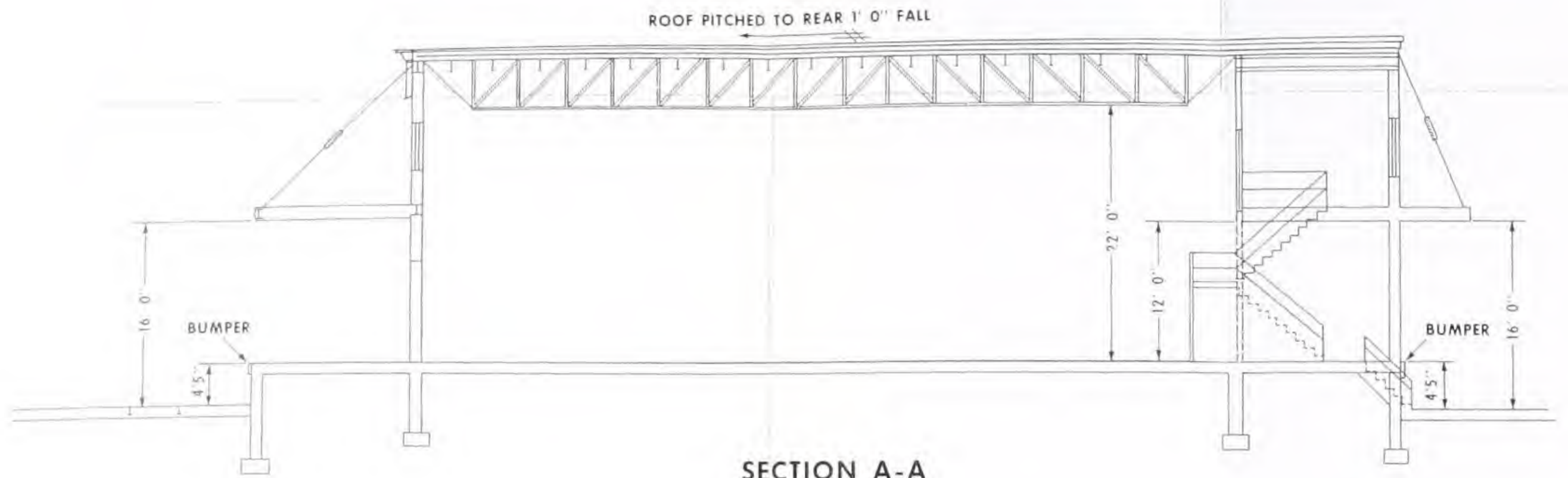

SECTION A-A

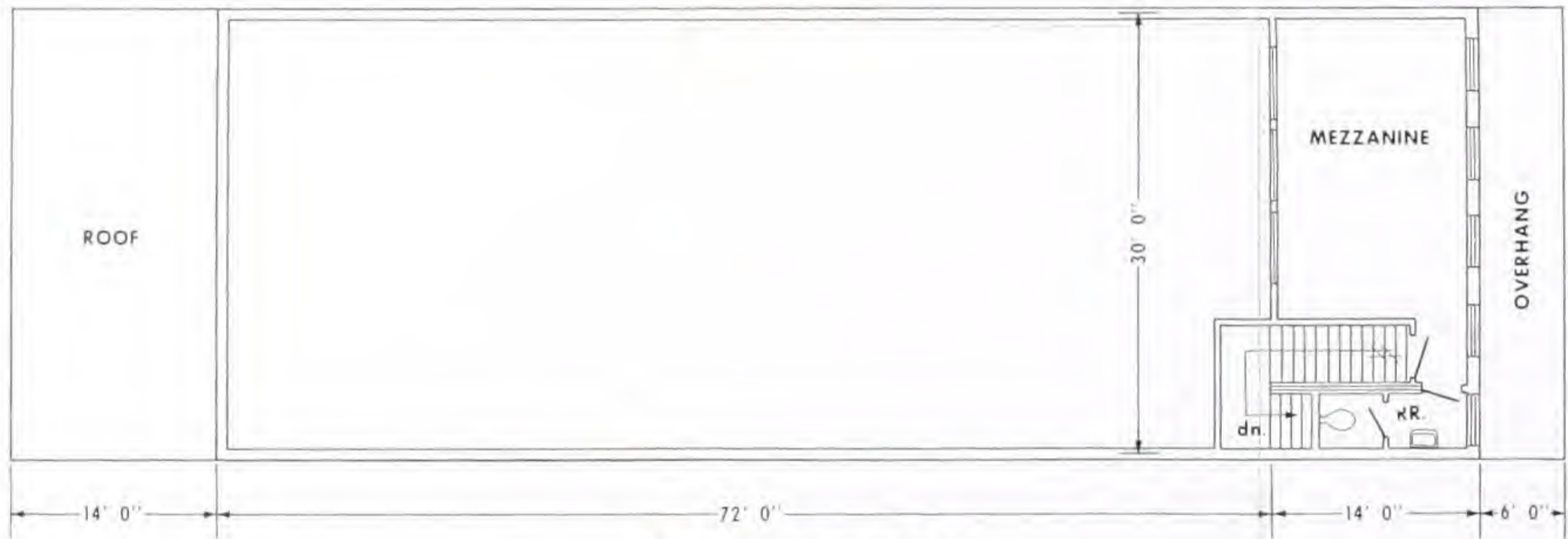

MEZZANINE PLAN

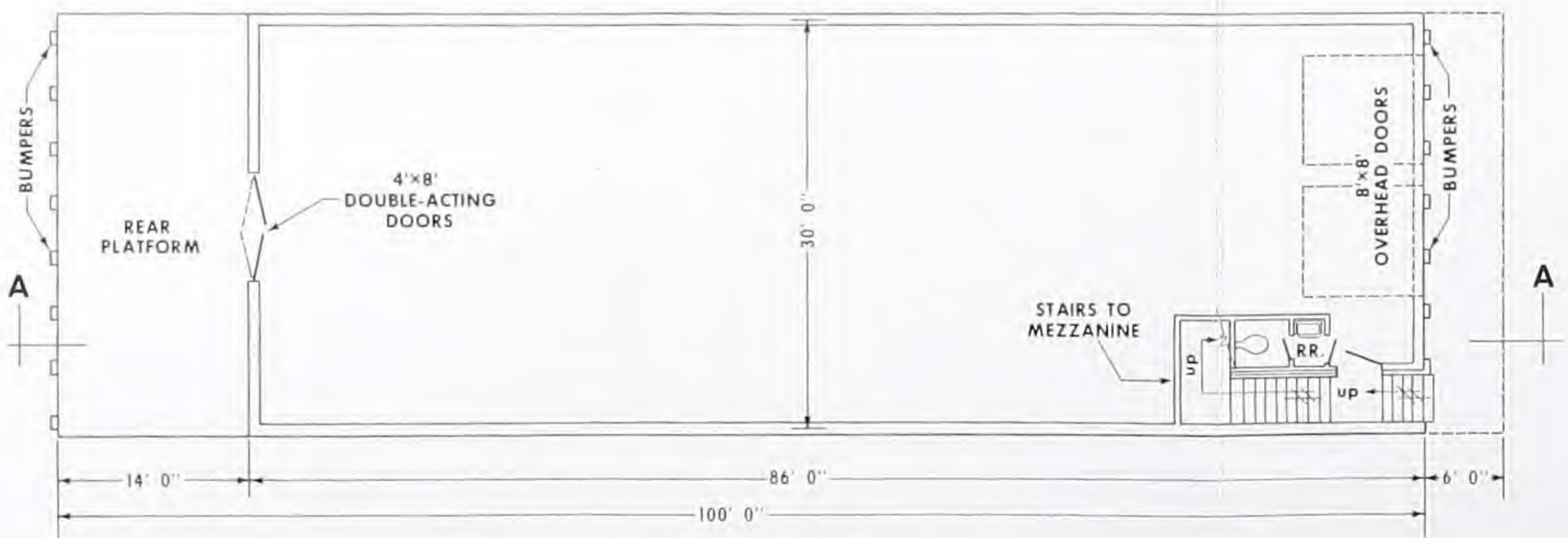

FIRST FLOOR PLAN

FIGURE 1.—Grocery unit and multiple-occupancy building.



because of their improper selection of handling equipment and too much or too little space.

The primary objectives of this study were:

1. To examine the handling equipment required for efficient operation.
2. To develop suitable layouts for various sizes of institutional grocery firms in multiple-occupancy buildings.
3. To determine the volume of grocery products that could be handled by these firms in specific amounts of space.
4. To examine the effect of volume on the decision to locate a wholesale grocery firm in a multiple-occupancy or a single-occupancy building.
5. To determine parking requirements for

various sizes of firms in multiple-occupancy buildings.

Warehouse operations were studied in 12 grocery firms to develop the material discussed in this report.

Productivity of warehousemen using various types of handling equipment was developed through the use of time studies and other industrial engineering techniques. The productivity of these employees does not always reach the levels indicated by the standard data presented in this report. Examples of factors that may cause productivity to differ from a normal rate are defects in the organization of the particular task and the skill, physical condition, and motivation of employees performing the task.

DESCRIPTION OF FACILITIES

Two basic types of grocery wholesale facilities used in urban food distribution centers are multiple-occupancy and single-occupancy buildings. Each type of building serves the needs of a particular size of grocery wholesaler.

Multiple-Occupancy Buildings

A multiple-occupancy building is a wholesale facility that is designed to house several individual firms. This report is concerned principally with this type of building. These buildings, usually from 300 to 600 feet long and 100 feet wide, are made up of several individual store units (fig. 1). Individual units are separated by full partitions extending from the front to the rear wall and from the floor to the roof. Partitions between units are usually waterproof and fireproof. They are removable to provide for future space adjustments by the wholesalers.

Most multiple-occupancy buildings have approximately 15 individual units, totaling about 45,000 square feet of first floorspace. Each standard grocery unit is 30 feet wide and 100 feet deep, including a 14-foot covered rear platform. A mezzanine, 30 feet wide by 14 feet deep, is provided at the front of each unit. Each unit contains 2,580 square feet of first floorspace, 420 square feet of rear platform space, and 420 square feet of mezzanine space, for a total of 3,420 square feet. The ceiling height

allows a minimum of 21 feet of clear stacking height except under the mezzanine. Construction is clear span from the mezzanine to the rear wall.

The front of the unit has two doorways, 45 inches above the pavement, at truck-bed height. Overhead doors, 8 by 8 feet, are installed in these doorways. Weather seals could be provided at the front doorways to prevent heat loss during loading and unloading in cold weather. A 6-foot overhang is provided along the front of the unit to protect products and workers during inclement weather. Each firm would be provided with a pedestrian access door at street level which would open to stairs leading to the first floor of the unit and the mezzanine. The mezzanine is for offices, light storage, and other uses.

The rear platform is the continuous length of the building and 45 inches above the pavement, at conventional railroad car-bed height. It is covered by a roof the width of the platform. Vertical rubber bumper strips should be attached to the building at both the front and rear to prevent damage by trucks.

Rails should be set into the pavement at the rear platform of the multiple-occupancy building to permit access to the platform by trucks and to facilitate cleaning the street. Double tracks would provide extra capacity for unusual rail receiving demands during peak peri-

ods, and the extra track could be used to unload directly from rail to trucks. The extra track would more often be used for switching operations, however, and not for receiving rail shipments.

Interior layouts of individual units are designed to meet the general needs of tenant firms. Typical layouts are discussed in a later section. Many firms will use pallet racks, however, and the first floor should be designed to support the resulting weight. The mezzanine floor should be capable of supporting office equipment and light storage.

Gas or electric space heaters are used for heating. Thermostats should be centrally located for efficient control of temperature.

Interiors of the units should be well lighted. An illumination of 10 to 15 foot-candles should be satisfactory on the first floor, but 15 to 20 foot-candles should be provided for office space and for repack operations (repacking small quantities of products for shipment).³ Central control for utilities should be conveniently located.

If frozen food handling is anticipated, floors should be constructed and insulated to prevent frost heaving.

Single-Occupancy Buildings

Because of the volume of products handled and the space required, some institutional wholesale grocers cannot operate efficiently in multiple-occupancy buildings. Such firms usually require a single building designed to serve their own particular needs.

Figure 2 shows a typical single-occupancy building for a wholesale grocer. This building is designed to serve a single firm handling conventional grocery items, dairy products, and frozen foods. It is divided into two main areas to provide for the needs of the wholesaler: one unrefrigerated area for dry storage and other needs and one area for refrigerated storage.

The unrefrigerated area measures 350 by 280 feet. This part of the warehouse includes a storage area and an overhead mezzanine for

offices. It also includes a combination truck receiving and shipping area, a separate truck receiving area, an enclosed rail line, and a rail receiving area. Overhead doors open onto the truck receiving and shipping areas. An open platform is provided at the rail receiving area, eliminating the need for locating railcars at door openings. Stairs provide access to the mezzanine. Twenty-one feet of clear space from floor to ceiling is available in all parts of this section, with the exception of the area under the mezzanine. Ceilings under the mezzanine are approximately 12 feet high. Floor heights are 45 inches above ground level.

The refrigerated storage area measures 130 by 160 feet and includes both a freezer and a cooler. Insulated doors with retractable shelters open onto an enclosed rail siding. A separate truck receiving and shipping area is available adjacent to the refrigerated storage area to allow frozen products to be moved directly between storage and trucks without crossing an unrefrigerated area. Insulated retractable seals are provided for these doorways. A doorway is provided to the rest of the warehouse to allow the assembly of mixed loads. Floors are constructed to prevent frost heaving. Refrigeration equipment is located in a separate room. A minimum of 21 feet of clear space is available throughout the refrigerated storage area. Floor heights are 55 inches above ground level at the rail platform to allow receipts from frozen food cars.

Adequate lighting should be provided over the order selection aisles in both dry and refrigerated storage areas. Lighting levels recommended for multiple-occupancy buildings would be adequate for single-occupancy buildings.

This warehouse is designed to handle an annual volume of approximately \$20 million in grocery products, \$11 million in frozen foods, and \$170,000 in dairy products. Additional volume could be handled by building more warehouse space in the expansion areas shown in figure 2. Both the dry and refrigerated storage areas have separate expansion areas. Expansion areas are located so that future building will not disturb existing operations in the warehouse, or the facilities for receiving and shipping by truck and rail.

³ All lighting estimates are based on information from the Illuminating Engineering Society Lighting Handbook and should be considered only as guides to specific lighting requirements of individual firms.

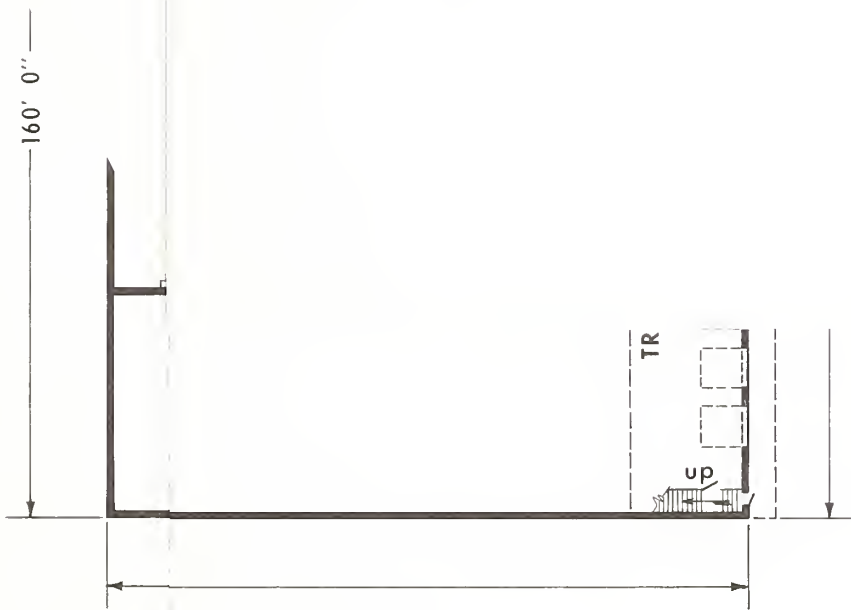

FEET
0 10 20 30

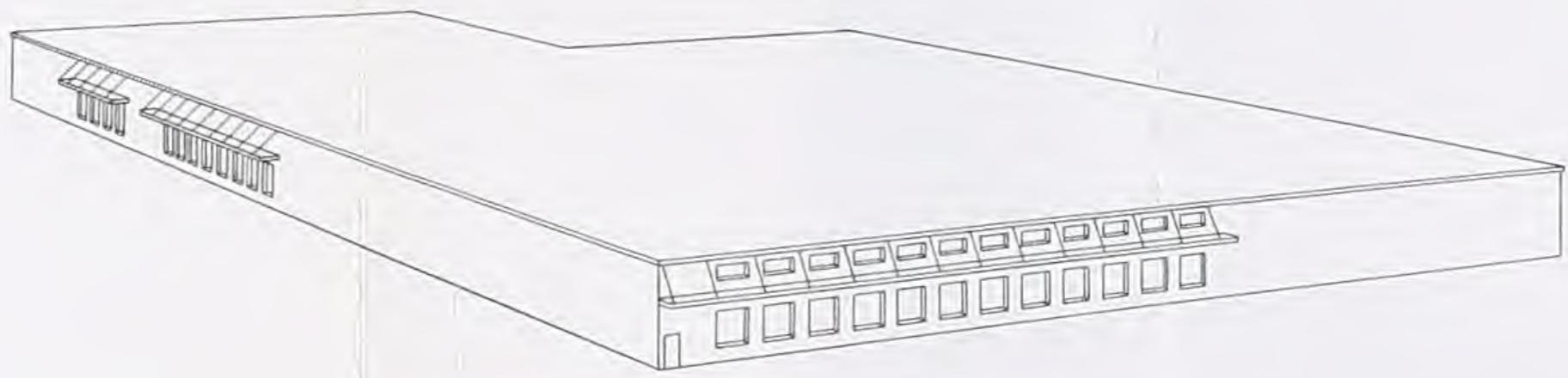

PERSPECTIVE

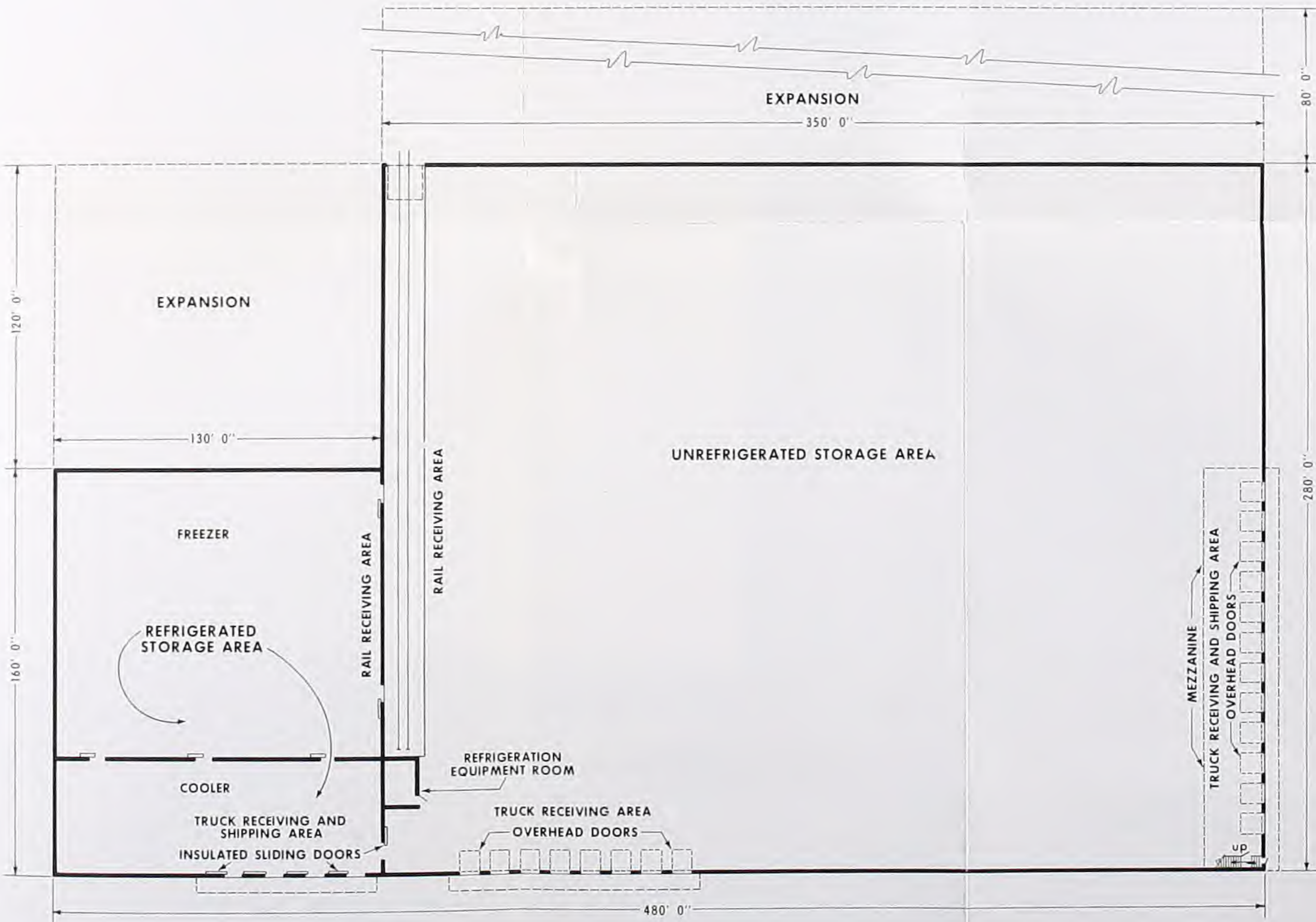

PLAN



FIGURE 2.—Single-occupancy building for a wholesale grocery.

HANDLING EQUIPMENT

Two main types of materials-handling equipment in multiple-occupancy buildings are forklift trucks and order selection equipment.

Forklift Trucks

Wholesalers planning to use a multiple-occupancy building for their warehousing operation should give particular consideration to their choice of forklift trucks. This equipment can greatly influence the layout of their facilities and their warehousing costs. The wholesaler needs to know what types of forklift trucks are available and how each type will affect the layout of the building and his warehousing costs and business profits.

Types of Forklift Trucks

Three types of forklift trucks can be used in multiple-occupancy buildings—counterbalanced, straddle, and extendable. Figure 3 shows typical examples of these forklift trucks with the type of pallet that each requires for operation.

Counterbalanced forklift trucks require a 10-foot-wide aisle in which to operate. This type of forklift truck uses a conventional pallet with the top and bottom surfaces having the same dimensions.

The straddle forklift truck can operate in a 7½-foot-wide aisle. This truck has outriggers that straddle the pallet as the load is lifted. Because the weight of the load is behind the wheels of the outriggers, a short truck is possible. Since the truck is short, it can make a right angle turn in a narrow aisle. A straddle forklift truck requires a special "single wing" pallet. The bottom surface of this pallet is smaller than the top to allow outriggers to straddle the pallet.

Extendable forklift trucks can also operate in a 7½-foot-wide aisle. This type of truck has forks mounted on a scissorlike mechanism so that they may be extended beyond the outriggers. Such a design enables the truck to "reach" out to pick up or set down loads without the outriggers having to straddle the load. Since the extendable forklift truck does not have to straddle its load, it can use the conventional pallets easily.

All the forklift equipment discussed in this report is assumed to be electrically powered. Butane and gasoline forklift trucks are available, but these types of trucks produce exhaust fumes which might pose a safety hazard in the limited space of a single unit. As multiple-occupancy buildings are divided into individual units, they are usually not equipped with high-capacity ventilation systems.

Several features are common to all three types of forklifts to be discussed. All are available with a wide range of motor and battery sizes, as well as with numerous accessories and with certain optional features that increase their efficiency and safe use in warehousing operations. All are designed to allow the operator to ride while the equipment is in motion. All can handle the pallet most commonly used by institutional wholesale grocers, which is 40 inches deep, 32 inches wide, and 6 inches high. All can raise a 2,000-pound load of products five pallet positions high, with a maximum lift of 205 inches. All are equipped with overhead guards to protect the driver.

Layouts With Different Types of Forklift Trucks

Firms using counterbalanced forklift trucks in multiple-occupancy buildings will have less floorspace available for storage and fewer aisles than firms using straddle or extendable forklift trucks. The amount of floorspace available for storage and the number of aisles will affect both the annual volume that a wholesaler can handle and the number of selection fronts available for order picking. (Selection fronts are the number of spaces available on the aisle for positioning items for selection. In this report, comparisons of selection fronts are made on the basis of pallet positions adjacent to the aisle and low enough for selection.)

Figure 4 shows two layouts that are suitable for an institutional wholesale grocery firm occupying five units of a multiple-occupancy building. Layouts recommended for various sizes of firms in multiple-occupancy buildings are discussed in a later section of this report. The layout in figure 4 A is designed for a wholesaler who will use a counterbalanced forklift

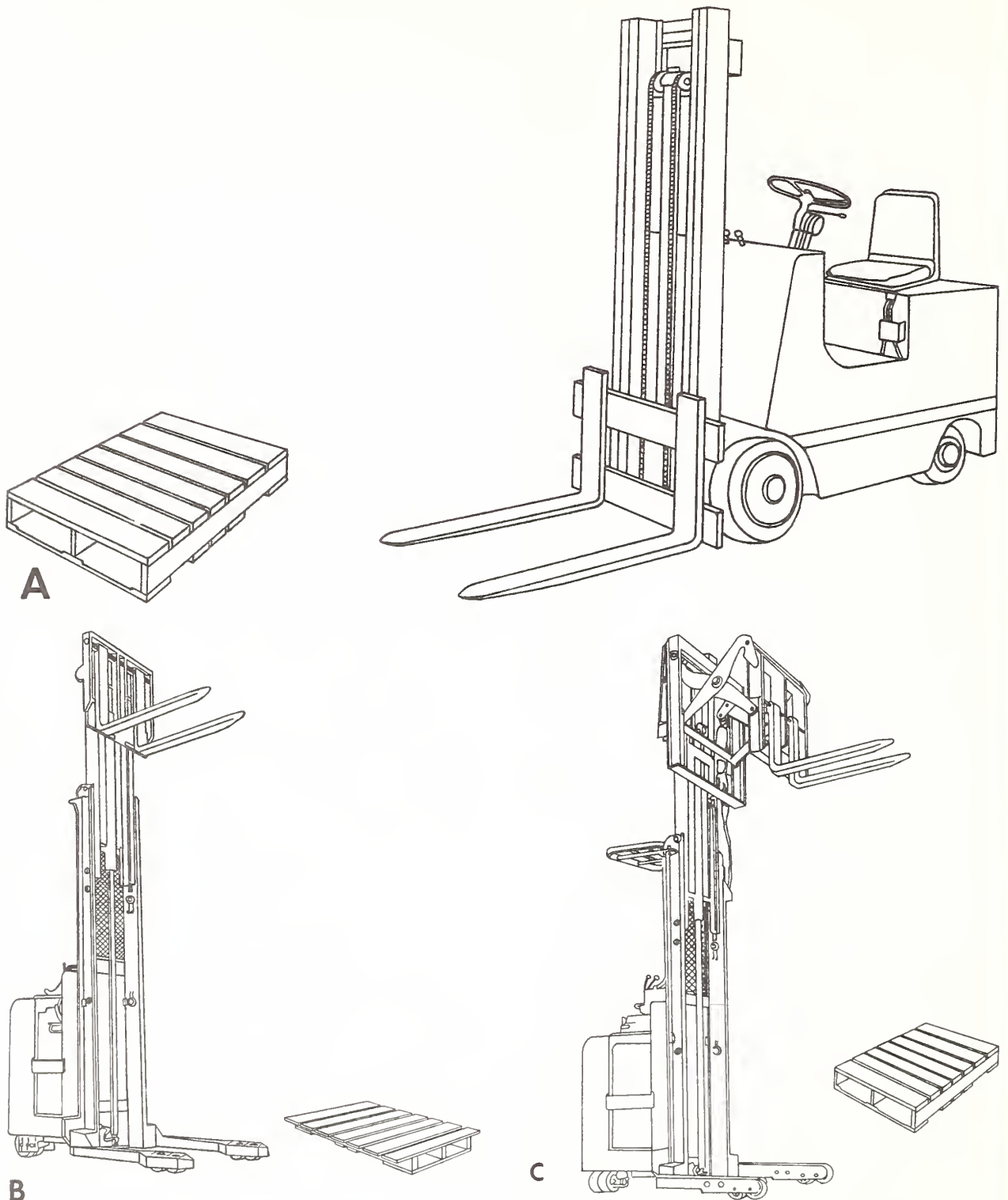

FIGURE 3.—Forklift trucks and pallets used in multiple-occupancy buildings: A, Counterbalanced forklift truck with conventional pallet; B, straddle forklift truck with single-wing pallet; C, extendable forklift truck with conventional pallet.

truck for his warehousing operations, while figure 4 B shows a layout designed for a wholesaler who will use straddle or extendable forklift trucks.

Table 1 shows the number of aisles, floor-space used for aisles, annual volume, and number of selection fronts available for use for a wholesaler occupying five units in a multiple-occupancy building, by type of forklift truck used. (These data are based on the layouts shown in figure 4.)

When a counterbalanced forklift truck is used, 5,997 square feet of aisle space is required as compared with 5,578 square feet when straddle or extendable forklift trucks are used—a difference of 419 square feet. The additional space used for aisles when a counterbalanced forklift truck is used results in a reduction of approximately 555 tons in a wholesaler's annual volume.

The table also shows that using counterbalanced forklift trucks causes the loss of approximately 336 selection fronts in a five-unit facility. Using straddle and extendable forklifts not only allows additional selection from pallet racks, but also provides still more selection by freeing space for shelving to handle items stocked in less than pallet quantities. The location and arrangement of these shelves is shown

in figure 4 B. Space is not available for shelving when counterbalanced equipment is used.

An institutional wholesale grocer should know the number of selection fronts that are available. Table 2 shows the number of different items that might be handled by a grocery wholesaler in a multiple-occupancy building. Of the 1,087 items handled, 171 items could be handled on shelves or in a repack area. The rest, 916 items, would be stored on pallets, either in racks or in a bulk storage area.

Cost of Using the Different Types of Forklift Trucks

Three costs associated with forklift operation are equipment, labor, and facility. Each can be expressed as the cost required for a forklift to move a loaded pallet from the receiving area to storage and return empty to the receiving area. These three costs combined form the total cost of using a particular forklift truck. The grocery wholesaler should study the total costs carefully to determine which type of forklift equipment would be the most economical for his use. The costs in this section have been based on costs for a firm using five units of a multiple-occupancy building.

A forklift truck will be used in a grocery firm for moving incoming products to storage

TABLE 1.—*Aisle space, annual volume handled, and selection fronts available for a 5-unit facility of a multiple-occupancy building, by type of forklift truck used*¹

Type of forklift truck	Width of aisle	Aisles ²	Aisle space ³	Pallets of products in inventory ⁴	Annual volume handled ⁵	Selection fronts ⁶
	<i>Feet</i>	<i>No.</i>	<i>Sq. ft.</i>	<i>No.</i>	<i>Tons</i>	<i>No.</i>
Counterbalanced.....	10	9	5,997	1,990	7,601	825
Straddle.....	7½	11	5,578	2,135	8,156	1,161
Extendable.....	7½	11	5,578	2,135	8,156	1,161

¹ Based on the layout for a wholesaler using a counterbalanced forklift truck (fig. 4A) and the layout for a wholesaler using either a straddle or extendable forklift truck (fig. 4B).

² Includes one aisle parallel to the rail platform (fig. 4). Excludes selection from bulk storage areas.

³ The space under the mezzanine is not high enough for pallet racks and not considered in this comparison.

⁴ Based on the first floorspace in the interior of a 5-unit facility of a multiple-occupancy building, excluding space for aisles, stairs, and the receiving, shipping, and order assembly area.

⁵ Based on the use of 5-high pallet racks, floor slots, 40- by 32-inch pallets, an average load in storage of 0.382 ton per pallet, and an average inventory turnover of 10 times a year.

⁶ Based on selection from the bottom 3 pallets.

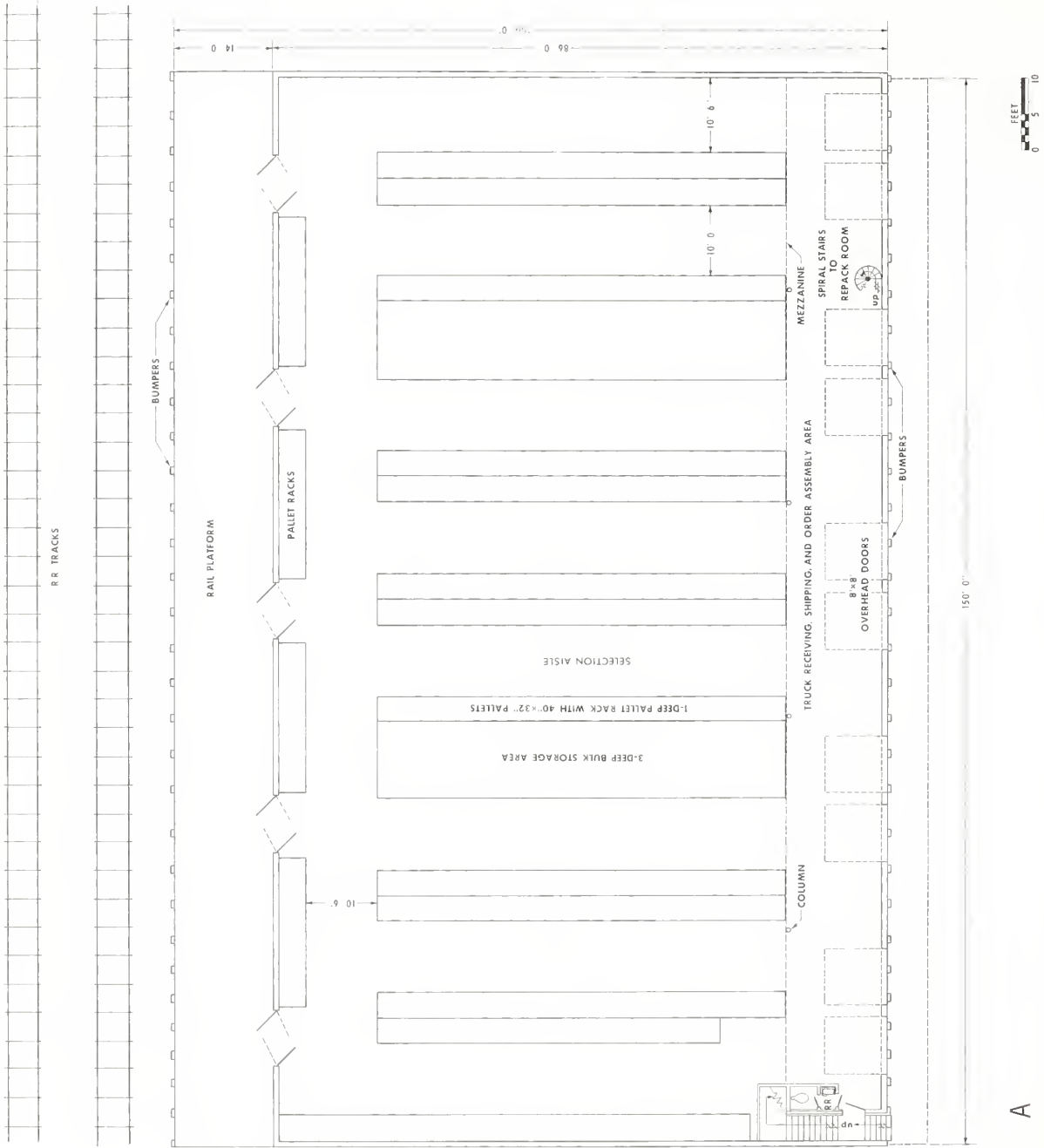

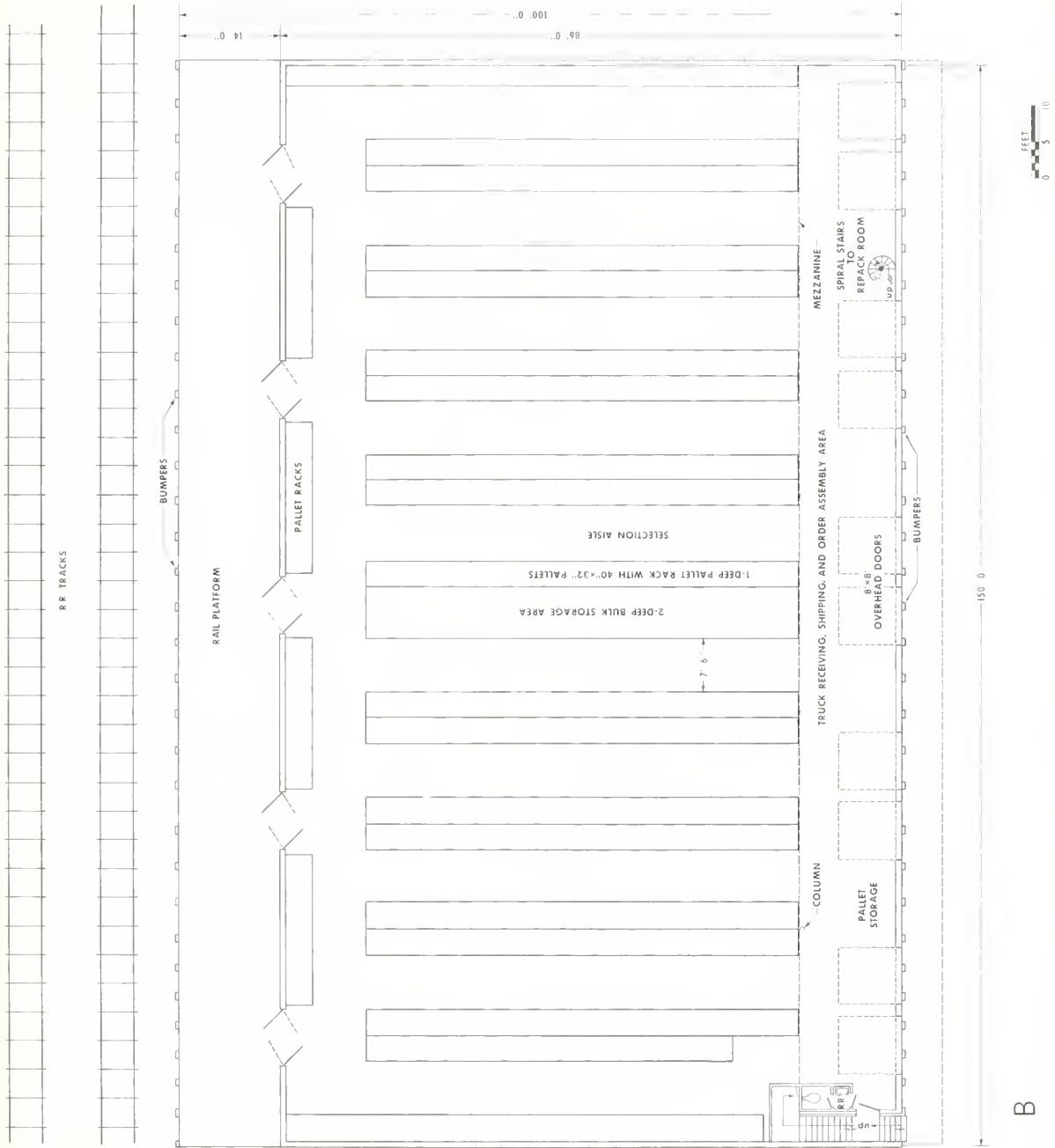

B

FIGURE 4.—Layout of an institutional grocery firm occupying five units of a multiple-occupancy building: A, Layout designed for use of counter-balanced forklift trucks; B, layout designed for use of straddle or extendable forklift trucks.

TABLE 2.—*Dry grocery items handled by institutional wholesaler, by type of storage required*¹

Item	Stored in	Stored on	Total
	repack area or on shelves	pallets ²	stored
	No.	No.	No.
Baking powder.....	0	2	2
Cakes, cookies, crackers.....	0	29	29
Catsups, sauces, mayonnaise, dressings.....	0	74	74
Cereals.....	0	29	29
Chinese foods.....	0	8	8
Cheese.....	0	3	3
Chocolate and cocoa.....	12	2	14
Coconut.....	5	0	5
Coffee.....	0	7	7
Dietetic foods.....	0	33	33
Baby food.....	0	6	6
Eggs.....	0	4	4
Fish and seafood - canned.....	0	16	16
Flour and flour mixes.....	0	48	48
Frostings.....	0	2	2
Fruits - canned.....	0	57	57
Fruits - dried.....	0	4	4
Gelatins, puddings, toppings.....	12	2	14
Pie fillings.....	0	14	14
Jellies, jams, preserves.....	0	33	33
Juices.....	0	50	50
Macaroni, noodles, spaghetti.....	0	45	45
Ravioli.....	0	4	4
Milk and milk products.....	8	2	10
Nuts.....	6	2	8
Oil, shortening, margarine.....	0	20	20
Olives, pickles, pickle relishes.....	0	51	51
Rice.....	0	9	9
Salt, salt substitutes, pepper, soda.....	4	8	12
Soups, soup mix, bases.....	0	53	53
Spices, flavorings, colorings, seasonings.....	111	0	111
Starches.....	0	6	6
Sugar, sugar substitutes.....	10	8	18
Syrups, molasses.....	0	7	7
Tea.....	0	7	7
Vegetables - canned.....	0	106	106
Vegetables - dried.....	0	22	22
Supplies.....	0	21	21
Insecticides.....	3	0	3
Mops, mop heads.....	0	8	8
Soaps, powders.....	0	40	40
Paper goods.....	0	58	58
Paper plates.....	0	16	16
Total.....	171	916	1,087

¹ Number and kind of items handled depend on the business practices of individual firms.

² Some partial pallet loads included in this category.

and for rehandling products in the storage area. Since the greatest part of its use will be for moving incoming products to storage, comparisons of the different types of forklift trucks will be based on this use.

Equipment and labor costs.—To calculate the equipment and labor costs, the cycle time for each forklift truck must be determined. (Cycle time is the time required for a receiving cycle; that is, the movement of a forklift truck in transporting a loaded pallet to storage and returning empty to the point of receipt.) These cycle times were developed from time studies of each type of forklift in actual operation. Each cycle time represents both total labor requirement and total elapsed time for the receiving operation.

Each type of forklift truck has a different cycle time. Table 3 summarizes typical cycle times for counterbalanced, straddle, and extendable forklift trucks, based on a travel distance between receiving and storage of 75 feet each way. The average travel distance was determined by averaging distances traveled over typical routes from the doorways at the receiving area to the storage locations and return. Use of a counterbalanced forklift truck requires a total of 1.08 man-minutes to complete a cycle. The straddle and the extendable forklift trucks require 1.22 and 1.38 man-minutes, respectively, to complete the same cycle.

The higher speed of the counterbalanced forklift truck results in a shorter cycle time than with either the straddle or extendable

TABLE 3.—*Cycle times for selected types of forklift trucks used by an institutional wholesale grocery firm in a 5-unit facility of a multiple-occupancy building*¹

Element	Labor required for—		
	Counterbalanced forklift truck	Straddle forklift truck	Extendable forklift truck
	<i>Man-minutes</i>	<i>Man-minutes</i>	<i>Man-minutes</i>
Pick up load in receiving area.....	0.11	0.09	0.19
Transport load to storage ²	³ .25	⁴ .31	⁵ .31
Set down load in storage.....	.49	.54	.59
Return empty to receiving area ²	⁶ .23	⁷ .28	⁸ .29
Total.....	1.08	1.22	1.38

¹ Productive time. Includes 10-percent allowance for fatigue and personal needs. Cycle times are based on the use of conventional and drive-in pallet racks. Cycle time is defined as the time required for a receiving cycle: the movement of a forklift truck in transporting a loaded pallet to storage and returning empty to the point of receipt and includes all the elements listed. Basic time data developed from research outlined in U.S. Dept. Agr., Mktg. Res. Rpt. 622, Storing Fruits and Vegetables on Pallets in Wholesale Warehouses, 1964. Lift height adjusted to maximum of 192 inches, reflecting pallet rack heights in a multiple-occupancy building.

² Travel distance (one way) 75 feet.

³ Productive time (minutes) = $0.00273 \times \text{distance (feet)} + 0.050$.

⁴ Productive time (minutes) = $0.00381 \times \text{distance (feet)} + 0.029$.

⁵ Productive time (minutes) = $0.00383 \times \text{distance (feet)} + 0.019$.

⁶ Productive time (minutes) = $0.00216 \times \text{distance (feet)} + 0.063$.

⁷ Productive time (minutes) = $0.00312 \times \text{distance (feet)} + 0.046$.

⁸ Productive time (minutes) = $0.00350 \times \text{distance (feet)} + 0.027$.

forklifts. The extra time required by the extendable forklift results from its additional movements in picking up and setting down loads.

Table 4 summarizes the total equipment cost per cycle for counterbalanced, straddle, and extendable forklift trucks used in a multiple-occupancy building. The per minute ownership and operating cost for each forklift was multiplied by its cycle time (table 3) to calculate the equipment cost per cycle.

Individual features of each forklift affect its equipment cost. The counterbalanced forklift truck, with its large motor and battery, costs \$0.023 per cycle. The simple design and low cost of the straddle forklift results in the lowest equipment cost per cycle (\$0.017). A complicated design and its high ownership and operating cost cause the equipment cost per cycle of the extendable forklift truck to equal that of the counterbalanced forklift truck.

Table 5 summarizes the equipment and labor cost per cycle for the three types of forklifts. Labor costs have been calculated by multiplying a wage rate of \$5.09 per man-hour by the applicable cycle times in table 3. Total equipment and labor costs with the counterbalanced and the straddle forklift trucks are about the same, \$0.115 and \$0.120, respectively, per cycle. The total equipment and labor costs for extendable forklift trucks are considerably higher, \$0.140 per cycle, or 2 cents per cycle higher than for the straddle and 2.5 cents per cycle higher than for the counterbalanced forklift trucks.

Facility cost.—The last of the three costs associated with forklift operation is the cost of facility per cycle. Table 6 shows the facility cost per cycle for five units of a multiple-occupancy building, by type of forklift used. This cost was calculated by dividing annual building rental of \$27,885 by the number of pallets of merchandise that were placed in the facility each year. In turn, the number of pallets placed in storage was calculated by dividing the annual product volume (see table 1) by an average pallet load of 0.382 ton (764 pounds).

Total cost.—The total cost of each forklift must be considered to provide the basis for se-

lecting the type that should be used in a grocery multiple-occupancy building. Table 7 presents the total cycle costs for a wholesaler using counterbalanced, straddle, or extendable forklift trucks in a five-unit facility of a multiple-occupancy building.

The forklift used has a considerable impact on the total cost of receiving products in a wholesale grocery multiple-occupancy building. Counterbalance equipment costs approximately \$1.516 per cycle; the narrow aisle straddle and extendable equipment are somewhat less expensive to operate, \$1.426 and \$1.446 per cycle, respectively (fig. 7). Labor costs per cycle are lower when counterbalanced equipment is used, but this reduction is offset by additional equipment cost and loss of storage space.

Total cycle costs for the various types of forklift equipment will affect the overall operating costs of institutional grocers. Obviously, other factors, in addition to the choice of forklift trucks, will affect the overall operating costs of a particular firm, such as the firm's business circumstances, the products it handles, and its operating practices.

Efficient utilization of storage space and maximum opportunity for selection were the most important factors considered in evaluating the relative merits of the different forklift trucks. These same factors would be equally important to a wholesaler using two, three, or four units.

Selecting a Forklift Truck

The use of both the extendable and straddle forklift trucks minimizes warehousing costs for a wholesaler in a multiple-occupancy building when compared with the use of a counterbalanced forklift. The extendable forklift truck has certain operational advantages over the straddle equipment. It uses a conventional pallet and allows the operator greater control in placing pallets in the upper tiers of pallet racks. For these reasons, many wholesalers may find that use of extendable forklift trucks in multiple-occupancy buildings is more practical, regardless of their slightly higher cost, than straddle forklift trucks.

TABLE 4.—*Equipment cost per cycle for selected types of forklift trucks used by an institutional wholesale grocery firm in a 5-unit facility of a multiple-occupancy building*

Equipment	Ownership cost per year				Operating cost per year				Total ownership and operating costs			Equip-ment cost per cycle ⁵	
	Years depreciation ¹	Initial cost ²	Depreciation	Interest at 6 percent	Taxes and insurance at 4 percent	Total	Electric power costs ³	Maintenance ⁴	Total	Per year	Per hour		Per minute
	Dollars	Dollars	Dollars	Dollars	Dollars	Dollars	Dollars	Dollars	Dollars	Dollars	Dollars	Dollars	Dollars
One counterbalanced forklift truck with overhead guard (2,000-lb capacity, electric, rider type, 205-in. lift).	10	10,250	1,025	338	410	1,773	-----	154	154	1,927	-----	-----	-----
Battery, 540 a.-r., 17.60 kw.-hr. Charger	6	1,547	258	54	62	374	-----	23	23	397	-----	-----	-----
	10	500	50	16	20	86	70	7	77	163	-----	-----	-----
Total		12,297	1,333	408	492	2,233	70	184	254	2,487	1,243	0.021	0.023
One straddle forklift truck with overhead guard (2,000-lb. capacity electric, rider type, 205-in. lift).	10	6,740	674	222	270	1,166	-----	101	101	1,267	-----	-----	-----
Battery, 540 a.-r., 12.58 kw.-hr. Charger	6	1,165	194	41	47	282	-----	17	17	299	-----	-----	-----
	10	500	50	16	20	86	50	7	57	143	-----	-----	-----
Total		8,405	918	279	337	1,534	50	125	175	1,709	.854	.014	.017
One extendable forklift truck with overhead guard (2,000-lb. capacity, electric, rider type, 205-in. lift).	10	8,190	819	270	328	1,417	-----	123	123	1,540	-----	-----	-----
Battery, 540 a.-r., 12.58 kw.-hr. Charger	6	1,165	194	41	47	282	-----	17	17	299	-----	-----	-----
	10	500	50	16	20	86	50	7	57	143	-----	-----	-----
Total		9,855	1,063	327	395	1,785	50	147	197	1,982	.991	.017	.023

¹ In accordance with U.S. Int. Rev. Serv. Bul. "F," based on reasonable life expectancy.

² Manufacturers' estimates, 1969.

³ Power costs for battery charging of electric-powered vehicles are computed from manufacturers' specifications. The formula used is as follows: Battery capacity (kw.-hr.) × discharge rate per hour (10 percent of battery capacity) × 2 (50 percent charging efficiency) × cost of electricity per kilowatt-hour (\$0.01) × hours of use per year (2,000) equals power costs (dollars per year). For example: 17.60 × 0.10 × 2 × 0.01 × 2,000 = \$70.40.

⁴ Maintenance costs were computed at 1½ percent of initial cost when machines were used 2,000 hours per year.

⁵ See table 3. Equipment costs per cycle are calculated by multiplying the total ownership and operating cost per minute by the appropriate cycle time.

Order Selection Equipment

Moving incoming products to storage is only part of the wholesaling operations that would be carried on in a grocery unit. Products also must be selected into orders and loaded into delivery trucks. The kinds of selection equip-

TABLE 5.—*Equipment and labor costs per cycle for selected types of forklift trucks used by an institutional wholesale grocery firm in a 5-unit facility of a multiple-occupancy building*

Type of forklift truck	Equipment cost per cycle ¹	Labor ²	Total
	Dollars	Dollars	Dollars
Counterbalanced -----	0.023	0.092	0.115
Straddle -----	.017	.103	.120
Extendable -----	.023	.117	.140

¹ See table 4.

² Based on table 3 and labor costs calculated as follows:
 \$2.97 per man-hour, basic wage
 Add 20 percent for labor-related elements of overhead and fringe benefits and prorate costs for 70 percent labor effectiveness.
 $\$2.97 \times (1 + 0.20)$
 ----- = \$5.09 per man-hour
 0.70

TABLE 6.—*Facility cost per cycle for selected types of forklift trucks used by an institutional wholesale grocery firm in units of a multiple-occupancy building*

Type of forklift truck	Pallet loads received annually ¹	Annual rent for 5-unit facility ²	Cost of facility per cycle
	Number	Dollars	Dollars
Counterbalanced -----	19,900	27,885	1.401
Straddle -----	21,350	27,885	1.306
Extendable -----	21,350	27,885	1,306

¹ See table 1.

² Based on a rental cost of \$1.859 per sq. ft. of first floorspace, or \$5,577 per unit per year. From Taylor, Earl G. and Miller, Franklin J., A Study of Food Distribution Facilities for Cincinnati, Ohio. U.S. Dept. Agr., Mktg. Res. Rpt. 825, 34 pp., Dec. 1968. Actual rentals for warehouse space in multiple-occupancy buildings could be substituted for the cited rentals for analyzing a specific wholesale firm.

ment used would be similar to those recommended for small firms in single-occupancy buildings.⁴ Wholesalers may choose from several types of selection vehicles, such as clamp trucks, pallet jacks, two-wheel handtrucks, dead and semilive skids, and four-wheel handtrucks (fig. 5). All these vehicles would operate efficiently in aisles designed for straddle or extendable forklift trucks.

Determining the proper order selection equipment is considerably less complicated than selecting the proper forklift truck. Layouts in multiple-occupancy buildings would not be affected by the choice of selection equipment. Aisle widths in these layouts are fixed by the choice of forklift truck. Facility costs would remain the same, regardless of the type of selection equipment chosen. Previous Department research investigated the relative labor and equipment costs of various types of selection equipment in considerable detail. This research showed the advantages of using four-wheel handtrucks in small single-floor warehouses, such as would be represented by a multiple-occupancy building.

Of the six types of order-selection equipment used in institutional grocery warehouses, only two—the two-wheel and the four-wheel handtrucks—are still in widespread use. The two-wheel handtruck when compared with other

⁴ See footnote 2, par. 3.

TABLE 7.—*Equipment, labor, and facility costs per cycle for selected types of forklift trucks used by an institutional wholesale grocery firm in a 5-unit facility of a multiple-occupancy building ¹*

Type of forklift truck	Cost per cycle			
	Equip-ment ²	Labor	Facility ³	Total
	Dollars	Dollars	Dollars	Dollars
Counterbalanced -----	0.023	0.092	1.401	1.516
Straddle -----	.017	.103	1.306	1.426
Extendable -----	.023	.117	1.306	1.446

¹ Based on an annual rental of \$27,885 and an inventory turnover of 10 times a year. See figure 4 for illustration of 5-unit grocery layouts with narrow and wide aisles.

² See table 3.

³ See table 6.

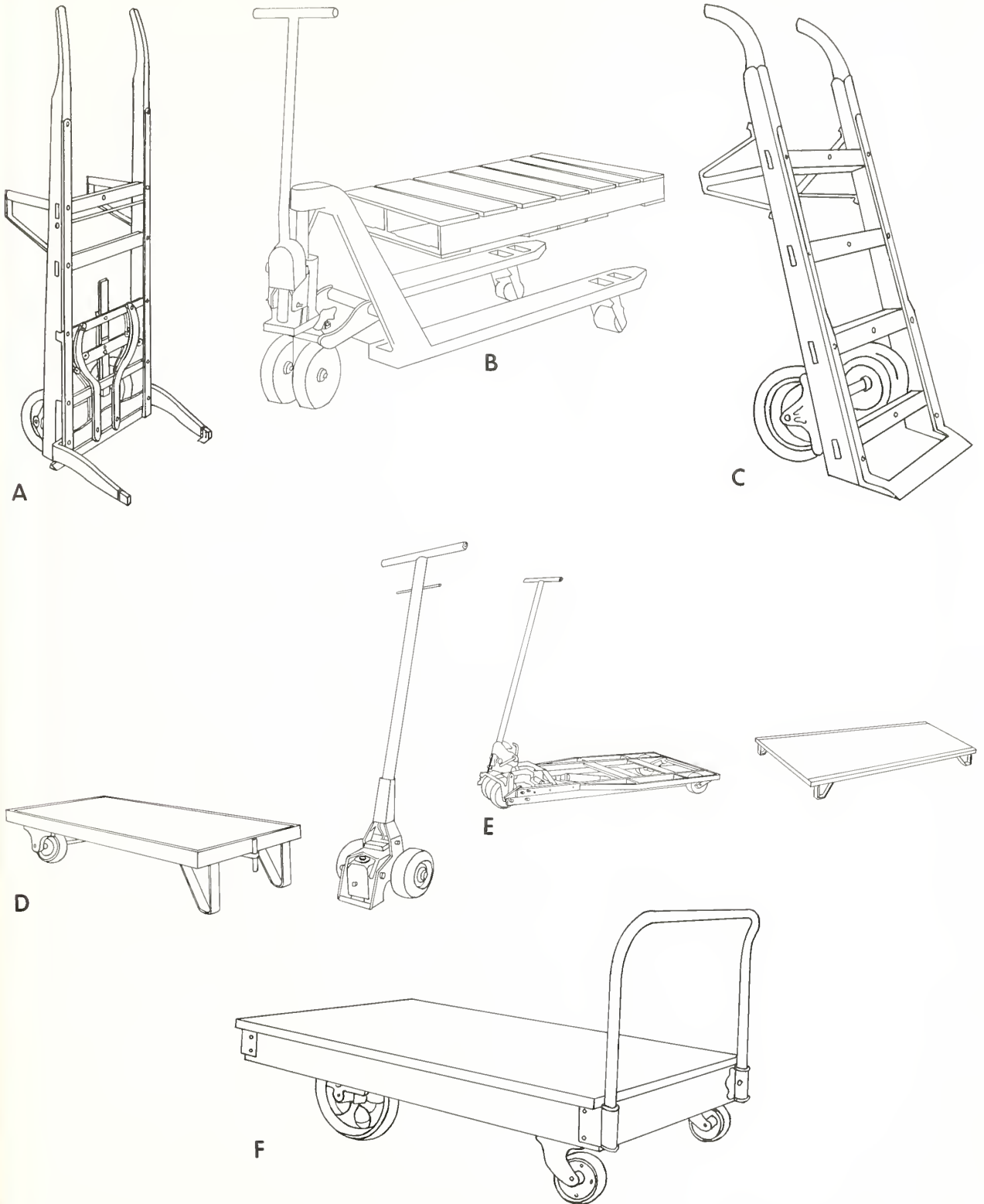

FIGURE 5.—Selection vehicles used in institutional grocery warehouse facilities: A, Clamp truck; B, pallet jack; C, two-wheel handtruck; D, semilive skid with jack; E, dead skid with jack; F, four-wheel handtruck.

selection equipment has a low initial cost and a low maintenance cost. In addition, it is more versatile and can be used in both receiving and shipping. A serious disadvantage of the two-wheel handtruck in order selection, however, is that it will accommodate only a limited amount of weight and bulk. Hence, nearly 85 percent more travel time is required for this truck compared with the four-wheel handtruck.⁵ The four-wheel handtruck has the same advantages as listed for the two-wheel handtruck, plus the advantage of being able to carry approximately three or four times as much weight and bulk as the two-wheel handtruck. In order selection, this means fewer trips to the shipping and order assembly areas with assembled orders.

Other types of selection equipment, such as manual pallet jacks, have limited use because of their specialized application. Pallet jacks are used when the products are delivered to customers on pallets. With this equipment, loaded pallets are moved directly into the delivery truck and unloaded directly at the food service outlet. This situation does not arise often for smaller institutional grocery wholesalers. Grocery firms more often use pallet jacks and pallets when an entire day's orders are selected before delivery trucks are loaded.

Even when a complete shift's orders must be stored, pallet jacks and pallets result in higher costs. Using pallet jacks and pallets for order assembly requires an initial investment of \$208 more than would be required with four-wheel handtrucks. This comparison of initial investment is based on using three order selectors per truck, each selector loading a total of four handtrucks. Twelve handtrucks, at \$75 each, would be required to load a moderate size deliv-

ery truck, for a total investment of \$900. Selecting with pallet jacks would also require four order selectors per truck. Each selector and the supervisor-checker would require one pallet jack, at \$265 each, as well as a total of 12 pallets, at \$4 each. The investment for this selection system would total \$1,108.

Pallet jacks and pallets used for order selection only do not offer any advantage in capacity over four-wheel handtrucks, as both types of equipment can carry approximately the same quantity of products per trip to the shipping and order assembly area. A few firms have used powered pallet jacks for order selection. They found that the speed and ease of travel of this equipment did not offset its high cost. Findings from a previous study indicate that a 50,000-square-foot warehouse is needed to justify powered selection equipment. (See reference listed in footnote 2, par. 3.)

Other selection equipment has limited use for various reasons. Clamp trucks often damage the bottom case during pickup and have limited capacity. Dead and semilive skids require manual or powered jacks to move over a selection route or out of a delivery truck. Neither type of skid has a larger capacity than a four-wheel handtruck. Wholesalers using such equipment usually have purchased their skids and jacks from industrial firms or food wholesalers that have acquired more modern handling equipment.

Conveyor systems have been used for selecting orders as well as for receiving in older, usually multistory, warehouses. Figure 6 shows several parts of such a system in operation. This type of handling system generally is not used in warehouses with high ceilings.

LAYOUT AND VOLUME HANDLED

The layout (internal arrangement) of wholesale facilities in grocery multiple-occupancy buildings is affected by the volume of products handled. Although different firms may use similar forklift trucks and selection equipment, the arrangement of the overall layout of wholesale facilities will differ to reflect the individual wholesaler's sales volume. The layouts discussed in this section represent the specific fa-

cility needs of various sizes of firms that may locate in grocery multiple-occupancy buildings. Particular business conditions or local circumstances may require changes in these arrangements.

All the layouts for individual firms are based on the standard grocery unit and multiple-occupancy buildings shown in figure 1. As a firm needs more space, several adjacent units can be used for expansion.

⁵ See footnote 2, par. 2.



FIGURE 6.—Conveyor systems in use in wholesale grocery operations for *A*, receiving and *B*, truck loading. BN-3131, BN-3142

Layout

All institutional wholesale grocers have certain common needs in multiple-occupancy buildings. Regardless of the firm's size, space must be provided for receiving, checking, and truck loading. Offices and restrooms must also be included in the layout. Some firms may decide they need the additional security of an optional repack room (a room where items handled in small quantities can be repacked into containers for shipment to the wholesaler's customers) to safeguard spices and other small and expensive products. In addition, space and equipment must be provided for storing all products between receipt and sale. Aisles in the storage area must be wide enough for efficient handling.

To meet these common needs, the layouts presented in this report share many common features. Sufficient space is available for receiving, checking, and truck-loading operations. Two areas are available for these purposes—one at the front of the unit, under the mezzanine, and one on the rail platform. These areas are intended to provide space for separating the palletizing of incoming products from the movement of loaded pallets to storage in the receiving operation, and to separate selection and truck-loading operations in order assembly. The area under the mezzanine is also used for stairs to the mezzanine, a first floor restroom, and temporary pallet storage.

Sufficient space is available on the mezzanine for offices, restrooms, and, if needed, repack rooms. These areas do not require high ceilings and are separated from actual warehouse operations. Locating these areas on a mezzanine frees valuable first floorspace for more productive use.

Four types of storage used by all firms in multiple-occupancy buildings are bulk storage, storage on drive-in pallet racks, storage on conventional pallet racks, and shelf storage of handstacked products.

Products to be stored in bulk storage areas would be received in large quantities, palletized, and moved directly to storage. There, the fully loaded pallets would be stacked, one on top of the other, from floor to ceiling. No provision for order selection would be provided in

this area. When the products are needed, they would be moved from the bulk storage areas and placed in the conventional pallet racks used for selection.

Drive-in pallet racks (fig. 7) may be used to store large quantities of products, such as flour, sugar, cereals, and paper, that might be damaged by stacking pallets one over the other. Such racks can be used for order selection and consist of horizontal rails connected to vertical supporting members. The rails are arranged perpendicular to the selection aisle and support pallets, one high, in the rack. Stacking height

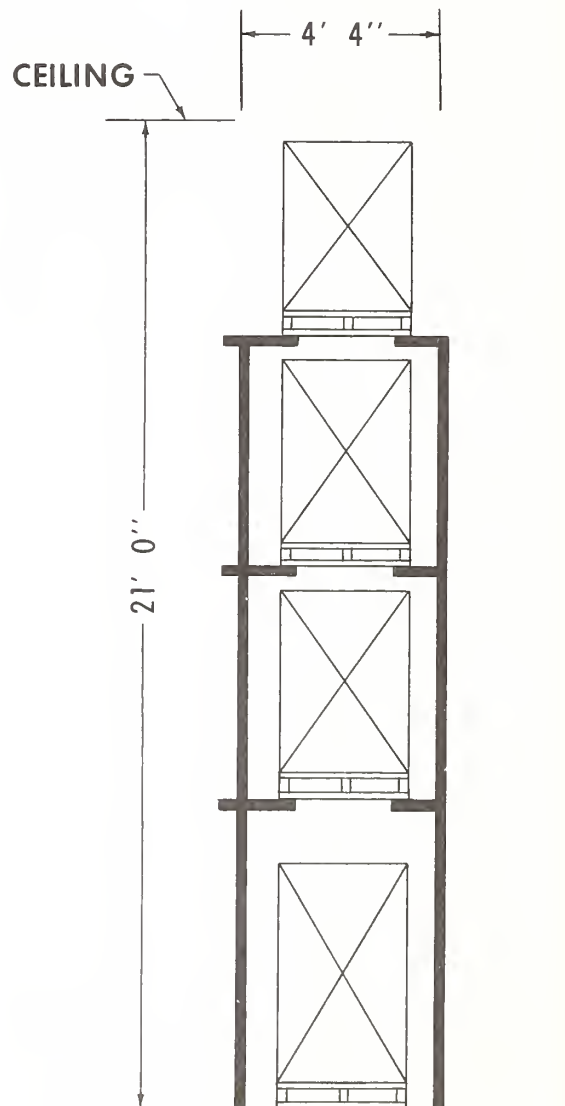

FIGURE 7.—Drive-in pallet rack.

may be adjusted by changing the height and spacing of the rails. Drive-in pallet racks often extend several pallets deep from an aisle and may be as high as the ceiling allows. They are closed at the back and may be placed against each other.

One version of a drive-in pallet rack occasionally used by institutional grocery wholesalers is the drive-through rack (fig. 8). This rack is similar in appearance to the drive-in rack, but it is open and may be entered at both ends. A drive-through pallet rack is secured to the floor and ceiling. This type of pallet rack offers

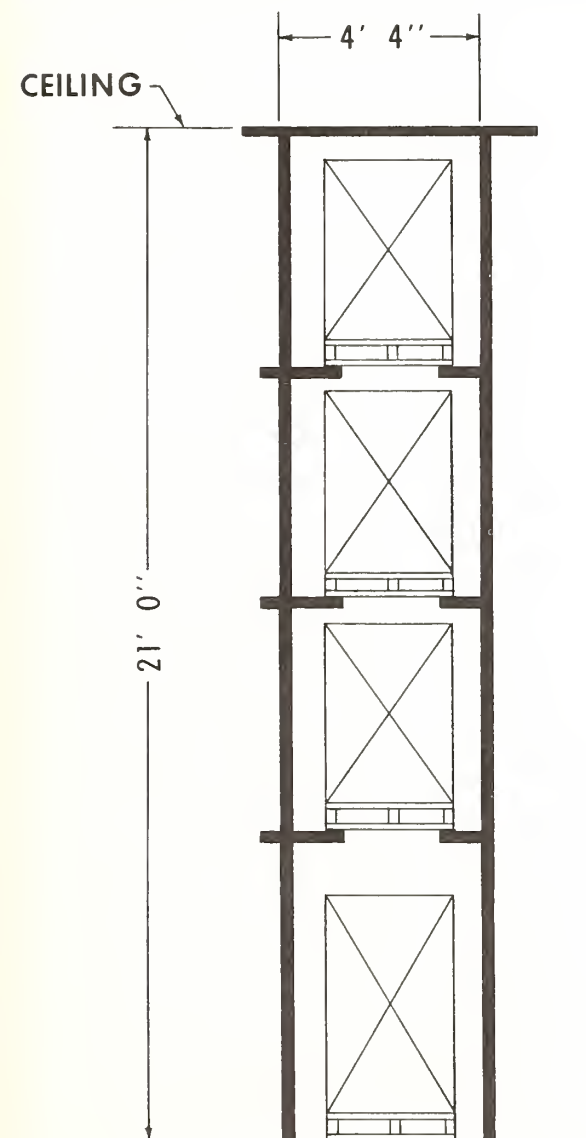

FIGURE 8.—Drive-through pallet rack.

some additional flexibility in storing large quantities of products.

The most common method of high-stacked storage is in conventional pallet racks. Figure 9 shows a conventional pallet rack arranged for maximum selection. These racks consist of horizontal bars connected to upright supporting members. The bars, which are parallel to the selection aisle, support pallet loads of products. Stacking heights can be changed in conventional pallet racks by adjusting the height of the bars. These racks can be altered to form shelving by replacing pallets with plywood sheets. Conventional pallet racks extend only one pallet deep from the aisles and several pallets high. Pallets in reserve storage may be placed one on top of the other over the highest supporting bar. Stacking height may vary on these pallets. Pallet racks of this type are usually arranged back to back, with all pallets directly accessible from a selection aisle.

When many items are being handled in less than pallet quantities, the wholesaler may wish to use metal shelves. The selection would be similar to that from a conventional pallet rack.

Aisles in the storage area will be wide enough to allow order selectors with their equipment to pass each other as well as a forklift truck. Several selectors and a forklift truck may be working in the storage area at one time and the forklift may need to pass the selection equipment in an aisle. Aisles 7½ feet wide per-

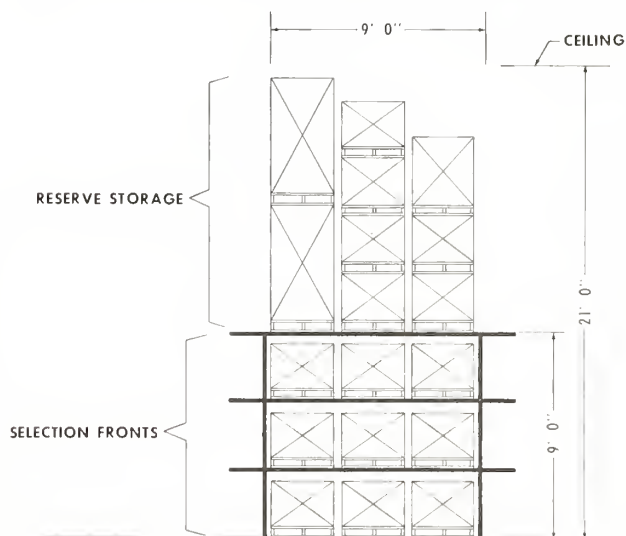

FIGURE 9.—Conventional pallet rack.

mit two selectors with their equipment to pass each other, and one selector, with his equipment, to pass a forklift truck.

Figure 10 shows the internal arrangement for a firm using two grocery units for its wholesale facility. The two units, combined, measure 60 by 100 feet. The arrangement shown provides an 840-square-foot truck receiving, shipping, and order assembly area under an overhead mezzanine. An optional repack room is also located under the mezzanine. This room is shown in figure 11.

Products would be checked at this location before being loaded into delivery trucks. Four trucks could be loaded at the same time, though, in practice, one or more of the doors at this location would be used for receiving operations during the day shift. Approximately 4,320 square feet are available in the interior of the unit for high-stacked storage. Conventional pallet racks are arranged in this space. A short conventional rack is located along the rear wall to allow maximum storage and number of selection fronts available.

A rear rail platform would permit direct rail shipments. It is unlikely that a two-unit grocery wholesaler would be receiving complete carloads of merchandise. The continuous platform would allow the firm to share incoming cars with other wholesaling firms in the same building. Approximately 840 square feet of rail platform space is available. Should the need arise, the rear platform could also be used for receiving truck shipments and pallet storage.

The office and a second restroom for office employees are located on the mezzanine over the truck receiving, shipping, and order assembly area. Figure 12 shows an office layout for a two-unit wholesaler. Removable panels allow furniture and equipment to be lifted to the mezzanine by forklift.

Figure 13 shows the internal arrangement for a three-unit institutional wholesale grocery facility. This facility, measuring 90 by 100 feet, would have approximately 1,260 square feet available under the mezzanine for a truck receiving, shipping, and order assembly area, as well as a repack room (fig. 11). This area would be large enough for limited receiving and normal truck loading operations to be carried

on at the same time. Six trucks could be served at the front of the facility. High-stacked storage would extend through the rest of the enclosed part of the wholesale facility. Approximately 6,480 square feet of floorspace would be available for storage and order selection. The rack arrangement in this area would be similar to the design outlined for the two-unit firm.

The rear platform provides approximately 1,260 square feet of space for rail-receiving operations. A three-unit wholesaler may receive an occasional railcar of mixed products and sufficient space would be available to allow an entire boxcar to be unloaded at the wholesale facility. The continuous platform would allow the three-unit firm to share incoming rail shipments with other firms in the same multiple-occupancy building. This platform space could also be used for truck receiving.

Offices for the three-unit firm would be located on the mezzanine. A separate restroom would be available on the mezzanine for office employees. Figure 14 illustrates the office layout for a three-unit firm.

Figure 15 illustrates an internal arrangement for an institutional grocery firm in four units, measuring 120 by 100 feet. Approximately 1,680 square feet of space are available under the mezzanine for a truck receiving, shipping, and order assembly area. Eight trucks can be served at the front of the facility. Enough space is available for both receiving and loading operations to take place at the same time. Approximately 8,640 square feet of first floorspace is adjacent to the mezzanine for high-stacked storage and aisles.

Storage methods in a four-unit facility would differ according to the amount of various products kept in inventory. A firm using four units could be expected to receive some items in large quantities, and these products would be stored in the bulk storage area shown in figure 15. Most of the items kept in inventory would be received a few pallet loads at a time and would be stored in the conventional pallet racks. Products received in less than pallet quantities would be stored on metal shelves provided for this purpose.

An open rail platform, totaling 1,680 square feet of floorspace, completes the wholesale facil-

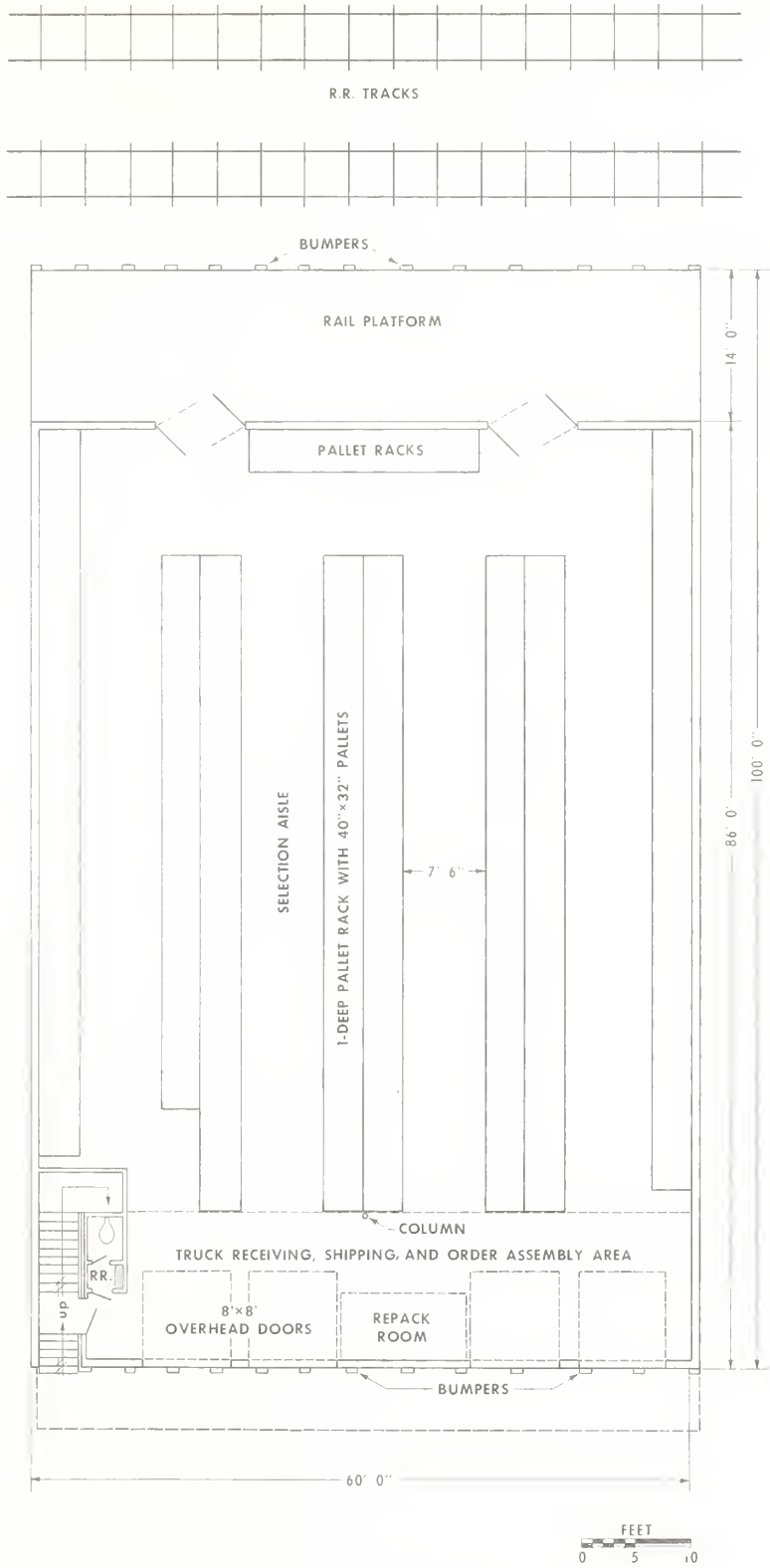

FIGURE 10.—Internal arrangement for an institutional wholesale grocery firm using two units of a multiple-occupancy building.

UNIT INTERIOR

TRUCK RECEIVING, SHIPPING, AND ORDER ASSEMBLY AREA

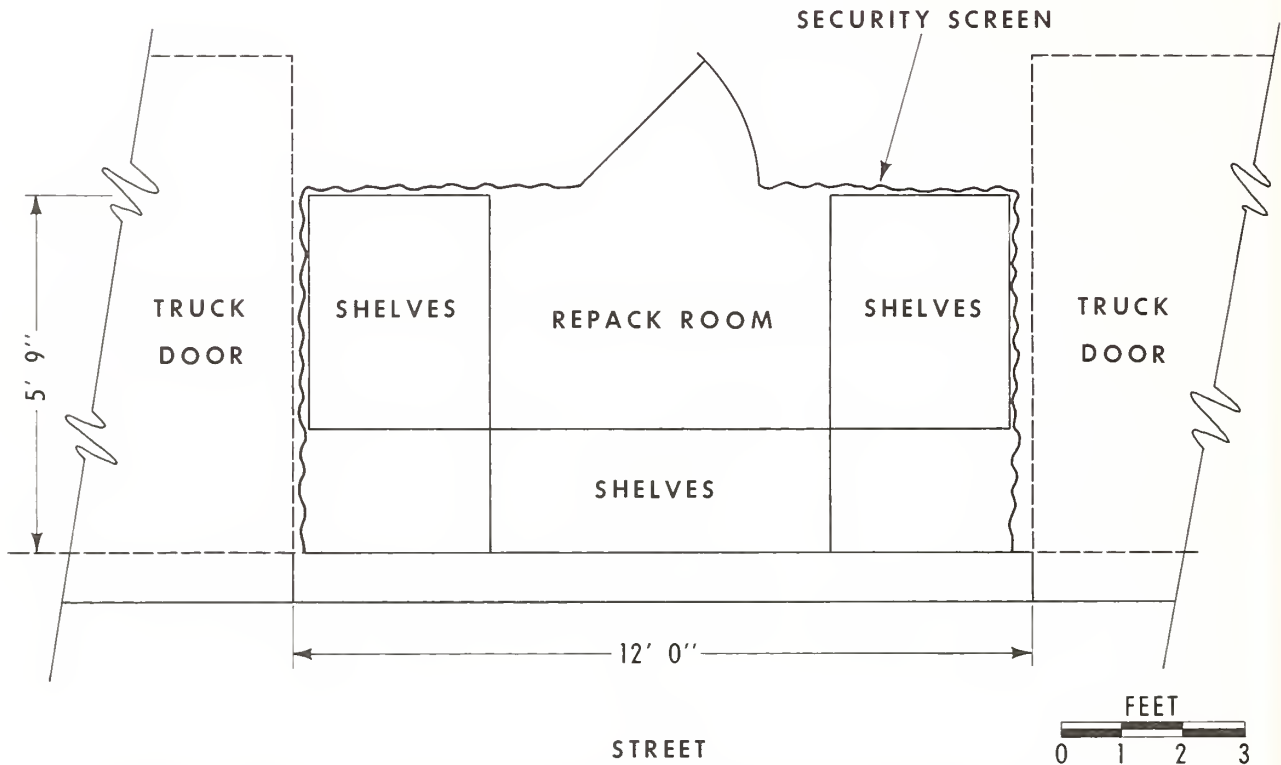

FIGURE 11.—Repack room layout for a firm in two units of a grocery multiple-occupancy building.

ity. Approximately two railcars could be unloaded on the platform at the same time. The continuous platform would allow the four-unit firm to share shipments with other firms in the same building. The rail platform also could be used for truck receiving.

The offices are designed for the anticipated number of clerical and management employees for a four-unit firm. Figure 16 shows the office design anticipated for an institutional grocery firm of this size. Two restrooms are located on the mezzanine for office employees.

A repack room would be located adjacent to the offices. Products would be received into the repack room through a door opening located over an aisle in the storage area. Pallet loads of

incoming products would be lifted to the mezzanine by a forklift truck. Repacked products would be sent to the first floor by a vertical conveyor. Figure 17 shows the design for an optional repack room to serve a four-unit wholesaler.

Figure 4 A shows a layout for an institutional grocery firm using five units of a multiple-occupancy building for its wholesale facilities. This layout was used as the basis for the previous discussions on the type of forklift equipment most suitable for use in a multiple-occupancy building. The five-unit facility measures 150 by 100 feet.

Approximately 2,100 square feet of space is available under the mezzanine for a truck re-

ceiving, shipping, and order assembly area. Enough space is available for both receiving and loading operations to take place at the same time. Ten trucks can be accommodated at the front of the wholesale facility.

Approximately 10,800 square feet of first floorspace is available adjacent to the mezzanine for high-stacked storage and for aisles. Storage in this area would be arranged similar to that in a four-unit wholesale facility. Bulk storage areas are provided for products handled in large quantities. Other products would be stored in conventional racks. Products handled in less than pallet quantities would be stored on metal shelves.

An open platform totaling 2,100 square feet of floorspace is available along the rear of the wholesale facility. This platform would allow three railcars to be loaded at the same time. The platform could be used for truck receiving when not being used for handling rail shipments. Rail shipments could be shared with other wholesalers along the continuous platform.

Figure 18 shows an office arrangement that should be suitable for a firm using five units of a multiple-occupancy building. Men's and wom-

en's restrooms would be available on the mezzanine for the office employees. The layout for the repack room on the mezzanine would be essentially the same as that for a four-unit firm (fig. 17).

Some institutional firms now using multiple-occupancy buildings have made efficient use of their facilities, while others have not.

Figure 19 shows how some wholesalers use their facilities. Figure 19 A shows the front exterior of a multiple-occupancy building occupied by an institutional wholesaler. In this particular design, an open platform approximately 3 feet wide has been provided to allow for pedestrian traffic among individual units. The doors shown in the photograph open into an order assembly area. A rail platform is at the rear of the building. Some of the doors shown have been fitted with wooden panels which can swing out to shield against the wind during receiving and loading operations.

Figure 19 B shows the bulk storage within a wholesale facility. This area features loaded pallets stacked from three to five high on both sides of an aisle. Racks are used to protect products from crushing on one side of the aisle. On the other side of the aisle, the pallets are

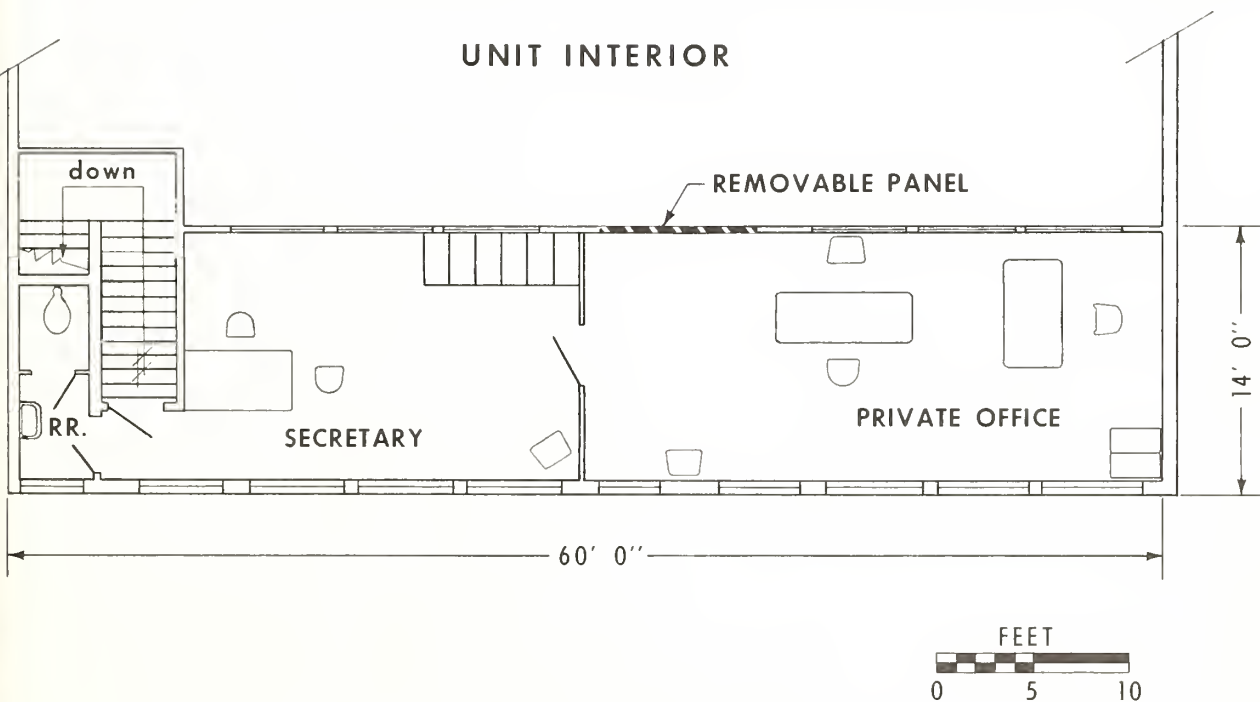

FIGURE 12.—Office layout for a firm in two units of a grocery multiple-occupancy building.

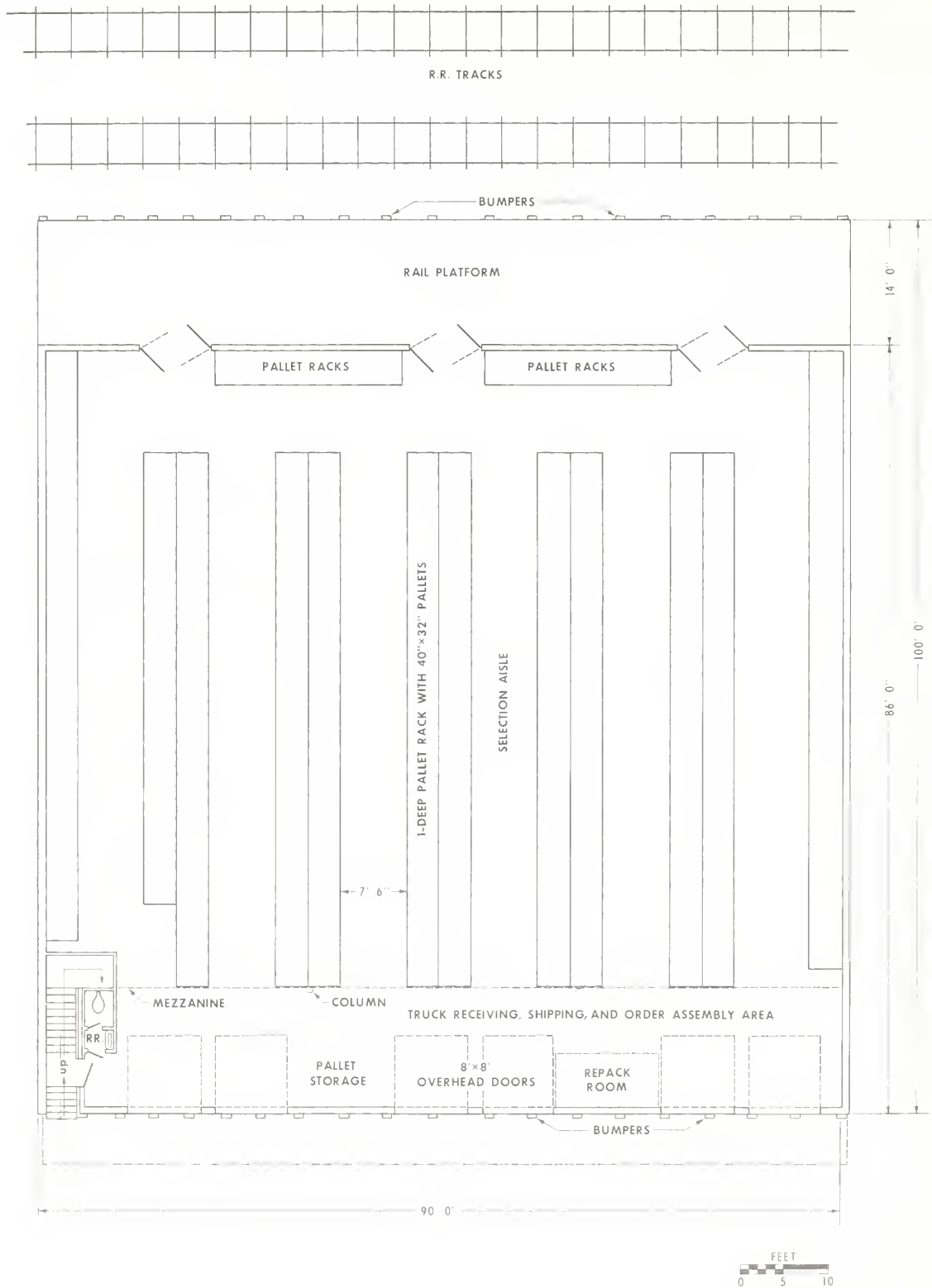

FIGURE 13.—Internal arrangement for an institutional wholesale grocery firm using three units of a multiple-occupancy building.

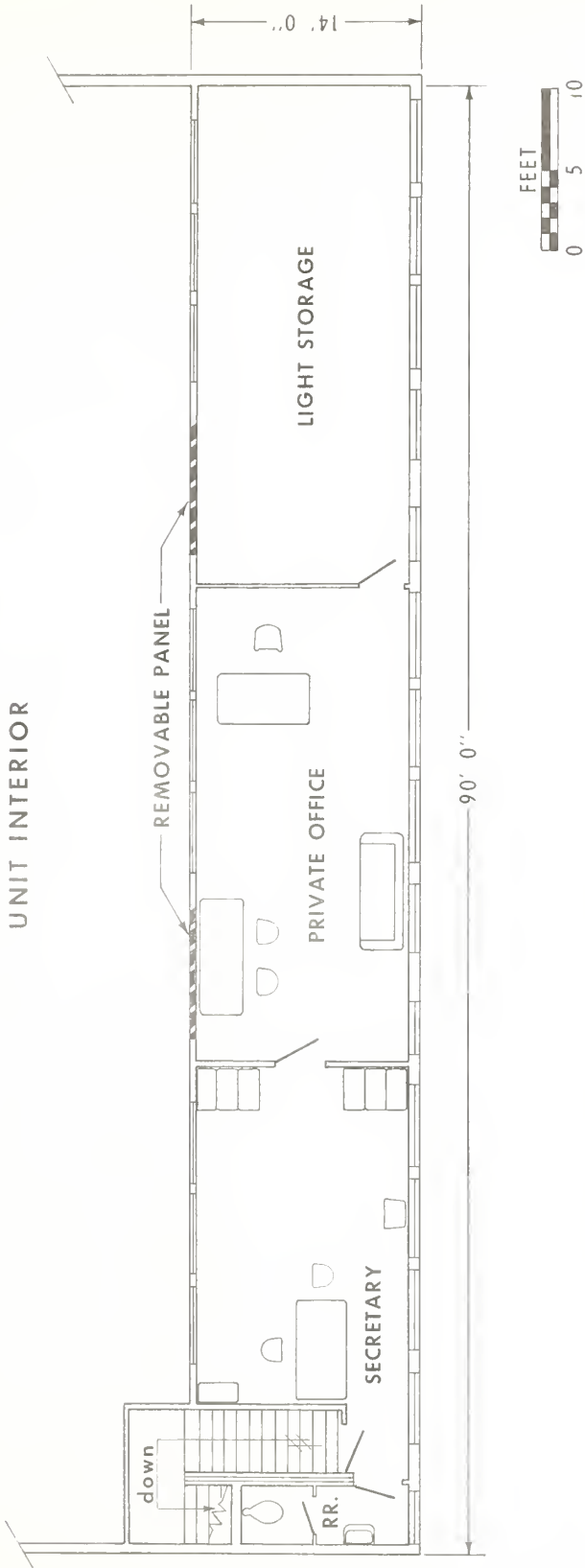

FIGURE 14.—Office layout for a firm in three units of a grocery multiple-occupancy building.

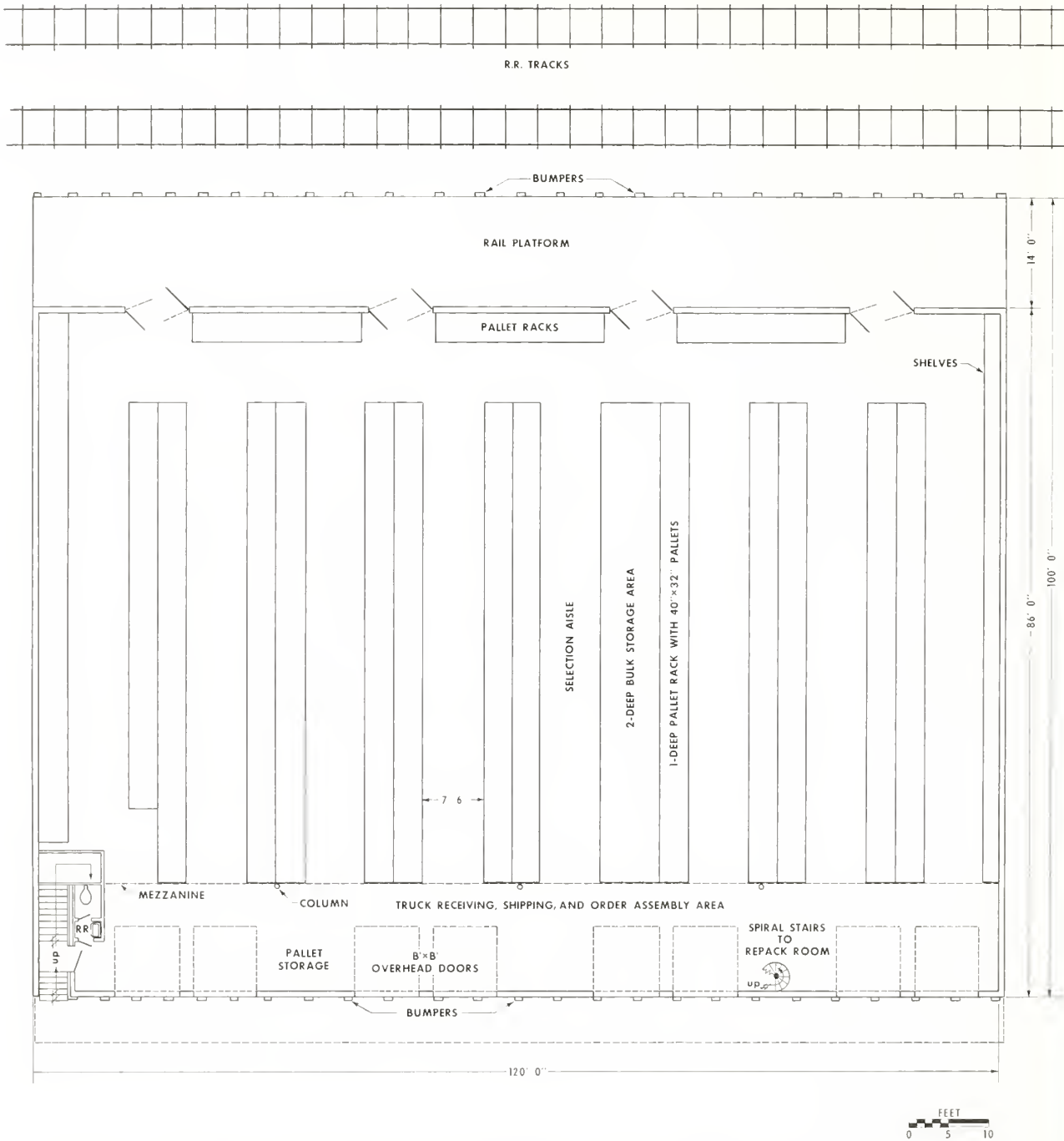

FIGURE 15.—Internal arrangement for an institutional wholesale grocery firm using four units of a multiple-occupancy building.

placed one directly on top of another as high as the ceiling will allow. Figure 19 *C* shows selection of orders from conventional pallet racks and *D*, assembled orders waiting to be checked and loaded into delivery trucks. A wide area is available to allow several orders to be placed in temporary storage. This area is used for receiving when not being used for delivery. Metal shelves are used in a repack room on a mezzanine (fig. 19 *E*). These shelves allow ample opportunity for selecting spices, sauces, and other items handled in this institutional wholesaler's repack room. The congested aisles shown here would hamper order selectors.

Volume Handled

Table 8 shows inventory, selection fronts, annual volume, and sales of institutional grocery firms in two, three, four, and five units. This table is based on the following assumptions:

1. The wholesaler using the units will make efficient use of his storage.
2. Some products will have been selected from available pallets.
3. Some reserve stock will have been partly exhausted.
4. One-tenth of the annual sales will be in inventory at one time.
5. Pallet racks will be used.
6. Incoming products will be handled by narrow-aisle forklift trucks.

Based on these assumptions, a two-unit firm should be able to handle an annual volume of 3,227 tons of grocery products, or sales of approximately \$1,290,800. A three-unit firm should be able to handle sales of 4,890 tons or \$1,956,000; a four-unit firm, 6,494 tons or \$2,597,600; and a five-unit firm, 8,156 tons or \$3,262,400.

TABLE 8.—*Inventory, selection fronts, and annual volume and sales by number of units used by an institutional wholesale grocery firm in a multiple-occupancy building*¹

Units used per firm	Average inventory ²	Selection fronts ³	Annual volume ⁴	Annual sales ⁵
	<i>Tons</i>	<i>Number</i>	<i>Tons</i>	<i>Dollars</i>
2-----	322.7	507	3,227	1,290,800
3-----	489.0	768	4,890	1,956,000
4-----	649.4	900	6,494	2,597,600
5-----	815.6	1,161	8,156	3,262,400

¹ Based on the use of narrow-aisle handling equipment, 7½-foot aisles, and pallet racks placed perpendicular to the loading and receiving areas.

² Based on the use of 5-high pallet racks, floor slots, 40- by 32-inch pallets, an average load in storage of 0.382 ton per pallet, and full utilization of available first floorspace.

³ Based on selection from the bottom 3 pallets, using reduced loads on pallets to make more products available for selection. Selection from bulk storage is not considered.

⁴ Based on a turnover rate of 10 times per year.

⁵ Based on an average valuation of \$400 per ton.

VOLUME OF BUSINESS IN RELATION TO SELECTION OF BUILDING

The institutional wholesaler must make certain that he selects a building that best suits his needs. His annual sales volume, the anticipated rate of growth of his firm, and the cost of available warehouse space should be carefully considered in making his choice.

If the wholesaler locates in space that does not allow adequately for expansion, he may

soon find that his volume of business has outgrown his facility. Expansion can pose particular problems for institutional firms housed in a multiple-occupancy building if they have not considered this factor in their selection of space. If they find that they need more space after their building has been completed and occupied, they may find that vacant units are

not available adjacent to their present facilities. Such firms may be forced to operate from scattered facilities or to move their entire warehouse operation to a single-occupancy building.

An institutional wholesaler who locates in facilities that are too large for his volume of business would not be using his space efficiently and the profit from his business may not offset the cost of the excess space.

A wholesaler who needs no more than 15,000 square feet of warehouse space, including space for expansion, and whose annual sales volume is less than \$3.3 million will probably find locating in a multiple-occupancy building practical. Here, he would be able to share parking, truck maneuvering areas, rail spurs, and platforms with other wholesalers.

REQUIREMENTS FOR PARKING SPACE

Institutional wholesalers deliver most or all of their volume, so they need space to park their delivery trucks. The space in front of the truck receiving doors of multiple-occupancy buildings would accommodate the delivery vehicles of most firms. If trucks were parked at other points along the front of the building, they would either block stairs or interfere with warehousing activities. Firms that operate only one shift a day will need to reserve some of this parking space for receiving to permit unloading and loading operations to be carried on simultaneously.

Table 9 summarizes the peak parking requirements for trucks for institutional grocery wholesalers in two, three, four, and five units of a grocery multiple-occupancy building during a typical week.

This table is based on several assumptions :

(1) No more than half the doors at the front of the building will be available for parking or loading operations at one time. The rest of the doors will be available for receiving.

(2) The delivery trucks will have a capacity of 2½ tons.

(3) Each truck will make two delivery runs each day.

(4) The wholesaler will deliver each week an equal percentage of the annual volume.

A wholesaler who needs more than 15,000 square feet of warehouse space would be one whose annual sales volume exceeds \$3.3 million. Many firms of this size are operating successfully in modern, single-occupancy buildings. This same sized firm would require six or more units in a multiple-occupancy building, making the wholesale facility almost twice as long as it is deep. Such a feature would require longer travel distances than would be necessary in the square design of the single-occupancy building. In addition, since the rail platform, mezzanine space, and truck receiving and shipping areas are fixed parts of the design of a multiple-occupancy building, a firm using an excessively large number of units may find itself with more space in these areas than it can use efficiently for warehouse operations.

(5) A maximum of 25 percent of the weekly volume will be delivered during one day.

TABLE 9.—*Truck parking requirements for various sizes of institutional grocery firms in multiple-occupancy buildings*

Size of facility	Weekly volume ¹	High daily volume ²	Trucks per firm ³	Available space in front of unit ⁴
	Tons	Tons	Number	Number
2 units.....	62	16	3	4
3 units.....	94	24	5	6
4 units.....	125	31	6	8
5 units.....	157	39	8	10

¹ Based on an even sale of grocery products throughout the year.

² Based on 25 percent of the weekly volume delivered in one day.

³ Based on using 2½-ton-capacity trucks, loaded to capacity, for 2 delivery runs per day.

⁴ Based on using half the space in front of the truck-receiving doors in the multiple-occupancy building for parking.

Based on these assumptions, no additional parking spaces for trucks would be required. However, supplementary parking of one space

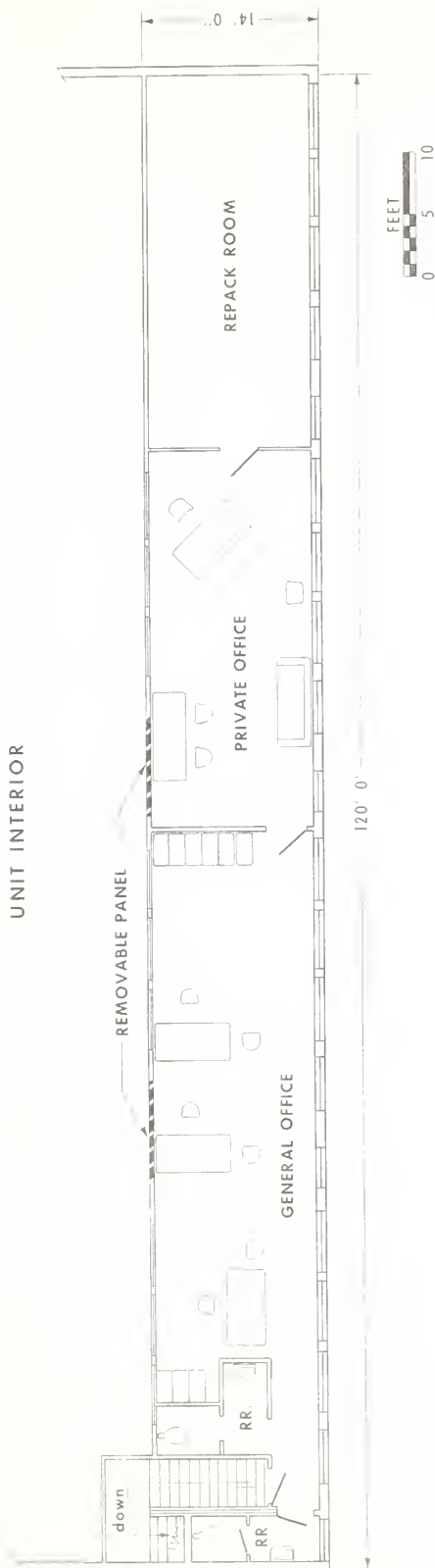

FIGURE 16.—Office layout for a firm in four units of a grocery multiple-occupancy building.

for each unit should be provided. This space would be for trucks belonging to outside firms that are waiting either to deliver products to the wholesaler or pick up purchases. The supplementary parking spaces should be located in the center of the 350-foot-wide street between multiple-occupancy buildings. They would be arranged in a single row, 50 feet deep, and extend the length of the street.

In most urban food distribution centers, sufficient parking space for cars is provided for employees and visitors. The number of parking spaces needed for each multiple-occupancy building depends upon the number of people working for the firms housed in each building. Some employees will use car pools or public transportation. Therefore, providing a parking space for each employee is not necessary. One parking space for each two persons employed in the building will be sufficient. A two-unit institutional grocery firm would have five parking spaces for cars; a three-unit firm, six spaces; a four-unit firm, nine spaces; and a five-unit firm, 12 spaces.

Table 10 summarizes the parking spaces needed for cars for wholesale institutional grocers in two, three, four, and five units of a multiple-occupancy building. It is based on interviews with institutional grocers during studies of food distribution in urban areas. The distribution of labor noted in the table relates only to parking requirements and should not be considered in any way as a recommendation in regard to labor requirements for efficient operation of a wholesale institutional grocery business.

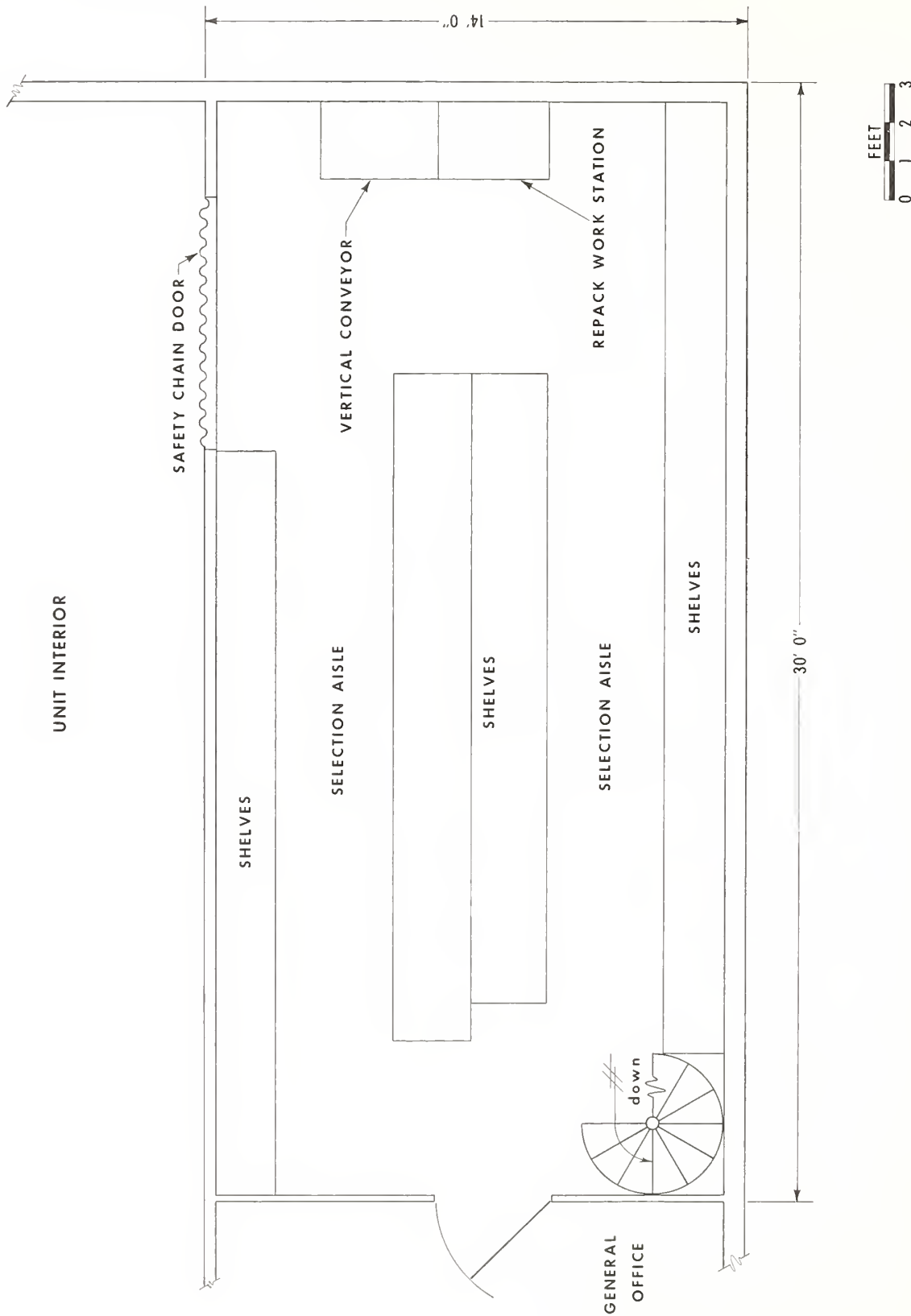

FIGURE 17.—Repack room layout for a firm in four-units of a grocery multiple-occupancy building.

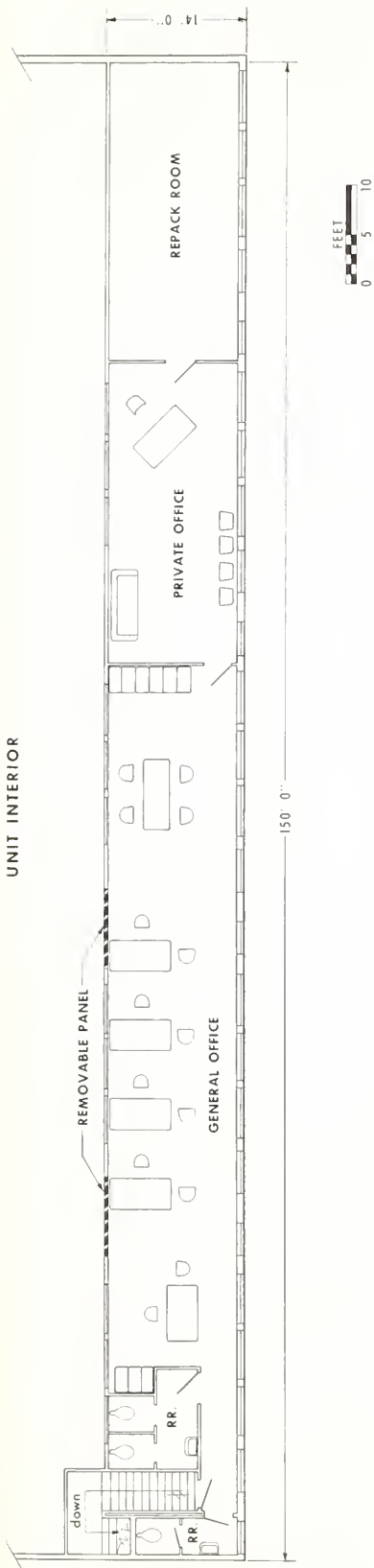

FIGURE 18.—Office layout for a firm in five units of a grocery multiple-occupancy building.

**A****B****C**

PN-2512, PN-2513, PN-2514, PN-2515, PN-2516

FIGURE 19.—Use of existing wholesale facilities: *A*, Building used by an institutional wholesaler; *B*, bulk storage; *C*, selecting orders from conventional pallet racks; *D*, assembled orders; *E*, shelving in repack room.



TABLE 10.—*Parking spaces required for employees and visitors by various sizes of grocery firms in multiple-occupancy buildings*¹

Size of facility	Employees per firm				Visitors ⁵	Required parking spaces per firm ⁶
	Office staff ²	Ware-house crew ³	Truck drivers ⁴	Total		
	<i>Number</i>	<i>Number</i>	<i>Number</i>	<i>Number</i>	<i>Number</i>	<i>Number</i>
2 units.....	2	3	3	8	1	5
3 units.....	2	4	5	11	1	6
4 units.....	4	5	6	15	2	9
5 units.....	6	7	8	21	2	12

¹ Based on interviews with wholesale institutional grocers.

² Includes salesmen who may use parking on an intermittent basis.

³ Includes receiving, order assembly, and maintenance workers.

⁴ Includes employees who may perform other warehouse duties in addition to driving delivery trucks.

⁵ Includes supplier salesmen and others who visit the wholesale facilities on an intermittent basis.

⁶ 1 space for every 2 persons.

