



AgEcon SEARCH
RESEARCH IN AGRICULTURAL & APPLIED ECONOMICS

The World's Largest Open Access Agricultural & Applied Economics Digital Library

This document is discoverable and free to researchers across the globe due to the work of AgEcon Search.

Help ensure our sustainability.

Give to AgEcon Search

AgEcon Search

<http://ageconsearch.umn.edu>

aesearch@umn.edu

*Papers downloaded from **AgEcon Search** may be used for non-commercial purposes and personal study only. No other use, including posting to another Internet site, is permitted without permission from the copyright owner (not AgEcon Search), or as allowed under the provisions of Fair Use, U.S. Copyright Act, Title 17 U.S.C.*

No endorsement of AgEcon Search or its fundraising activities by the author(s) of the following work or their employer(s) is intended or implied.







12885181

USDA, National Agricultural Library
NAL Bldg
10501 Baltimore Blvd
Beltsville, MD 20705-2351

12885181

Historic, archived document

Do not assume content reflects current scientific knowledge, policies, or practices.

Ag 84 M.
551

AUG 15 1962

BELTSVILLE BRANCH

AUG 15 1962

U. S. DEPARTMENT OF AGRICULTURE
BELTSVILLE BRANCH

IMPROVED METHODS of DISPLAYING and HANDLING PRODUCE in Retail Food Stores



LIBRARY

RECEIVED

AUG 15 1962

U. S. DEPARTMENT OF AGRICULTURE
BELTSVILLE BRANCH

Marketing Research Report No. 551

U. S. DEPARTMENT OF AGRICULTURE
Agricultural Marketing Service
Transportation and Facilities Research Division

IMPROVED METHODS OF DISPLAYING AND HANDLING PRODUCE
IN RETAIL FOOD STORES

by

Dale Anderson, P. Shaffer, and M. Volz

UNITED STATES DEPARTMENT OF AGRICULTURE

Agricultural Marketing Service

Transportation and Facilities Research Division

Washington, D. C.

July 1962

PREFACE

7-11-58

This report is the fifth in a group about handling produce in retail food stores. The study on which it is based is part of a larger marketing research project designed to increase the operating efficiency of retail food stores so as to cut costs of marketing farm products. The work is being conducted under the general supervision of R. W. Hoecker, chief, Wholesaling and Retailing Research Branch, Transportation and Facilities Research Division, Agricultural Marketing Service.

Produce is one of the highest operating-cost departments in retail food stores and requires a disproportionate share, in relation to dollar sales, of the estimated 4-billion-dollar labor bill for food stores in 1960.

The methods and procedures described in this study, when adopted, will materially help to increase productivity of labor and acceptability of farm produce at retail. This type of cost-saving marketing research, coupled with production research, has helped to keep the consumer's food costs from rising as rapidly as have the costs for other goods and services. Retail farm food prices have risen only 13 percent since 1947-49, while nonfood prices during the same period have risen 31 percent. The American consumer in 1947-49 spent approximately 25 percent of his take-home pay for food; in 1961 his bill was less than 20 percent of his take-home pay.

Subjects covered in previous reports include receiving and storage, trimming, packaging, and sales area layout, and customer service. An additional publication on layouts of produce departments is planned. Improved produce department operations, based on Agricultural Marketing Service research, have been installed in at least 300 supermarkets. The resulting savings reported for a number of these stores average annually at least \$5,000 per store, which would amount to a total annual savings of over \$1.5 million if equal results were achieved in all 300 stores.

Many retail operating and executive personnel assisted in the project and approximately two dozen retail firms participated in various phases of the project. Many State Department of Agriculture and Extension Service workers assisted in the research.

CONTENTS

	<u>Page</u>
Summary.....	5
Background and purposes of the study.....	7
Functions performed in displaying produce.....	7
Transferring new merchandise to display counters.....	9
Use of hands in displaying.....	9
Types of displays.....	10
Price-marking on the sales floor.....	13
Rotation of produce displays.....	13
Handling shipping containers.....	17
Miscellaneous tasks performed on the selling floor.....	17
Takedown.....	20
The materials-handling task in produce display work.....	20
Selecting merchandise and loading for display.....	21
Transporting merchandise to the display.....	21
Work planning by the produce department manager and personnel.....	23
Planning counter arrangement.....	23
Organizing produce display work to reduce travel.....	24
Equalizing the display workload.....	28
General principles for display work.....	28
Display cases.....	30
The preparation of display counter bases.....	30
Multideck displays.....	34
Rear-service display cases.....	34
Unit handling.....	36
Tray display.....	36
Restocking the display case.....	36
Counter setup.....	39
Takedown.....	39
Preparation of trays.....	39
Advantages of tray display.....	40
Rolling or mobile displays.....	42
Portable display bin.....	42
Watermelon racks.....	44
Mobile multishelf displays.....	45
Effect of use of tray display and rolling display bins.....	46
Literature cited.....	48
Appendix.....	49

SUMMARY

The objective of this study was to evaluate conventional display procedures and to develop and test improved equipment, display methods, workplace arrangement, and work organization. Detailed studies were made in retail stores of 12 large food chains and voluntary food store organizations. Numerous other studies were made in various other stores throughout the United States. An analysis of all produce labor in four retail food stores indicated about one-third of this time was spent on display work in bulk produce stores and about one-fourth in prepack stores.

Demonstrating in two supermarkets the improved methods of produce display outlined below resulted in 23 and 28 percent savings in labor. These savings amounted to 26 and 30 hours per 1,000 cases of produce handled. When the tray display method was used together with rolling bins for potatoes and onions, an additional 8 to 19 hours per 1,000 cases was saved. Additional benefits were noted in increased rotation of product and better maintenance of displays.

The following general rules for good produce display work incorporate most of the improvements developed:

1. Plan the work ahead.
2. Do as much work as possible in the backroom.
3. Take a large load to the counters and plan an efficient work cycle.
4. Carry necessary tools and supplies.
5. Park the cart close to the display.
6. Position the box of produce close to the body of the handler.
7. Use both hands, moving together, to transfer merchandise.
8. Use dump or loose displays where possible. Avoid bruising damage.
9. Place the whole container with its contents on display where possible.
10. Keep merchandise on displays at reasonable heights.
11. Follow an orderly path at the counter.
12. Use containers that nest and stack.
13. Get rid of garbage, trash, and salvage as they accumulate.

Improved methods of selecting and hauling merchandise to the selling area increased the average number of cases hauled each time from about two and one-half to four and saved 1/3 to 1/8 minute per case.

The following rules to reduce rehandling of produce were developed.

1. Relate display size to expected sales and conditions of produce.
2. Avoid display fixtures with deep recesses.
3. Rotate when needed and only then.
4. Keep displays separate when different lots of a given product vary in quality, size, or condition.
5. Keep quantity of produce low early in the week.
6. Allow display depth to diminish considerably before replenishing.
7. Use counter liners where possible.

Factors which were found to be of greatest help in equalizing the display workload were:

1. Rotate and load counters before expected sales peak periods.
2. Accomplish as much work as possible before the expected sales peak period, such as premarking citrus, packaging, pricing, and trimming.
3. Prepare ahead of time the loads of merchandise which will be needed in the produce department.
4. Place the items on the dry counters in the evening, so that wet and perishable items can be handled exclusively in the early morning.
5. Work during the slack periods on bulky items which tend to create congestion on the floor.
6. Provide written work assignments for help, especially for slack periods and evenings.

Improved counter base designs were developed to reduce the labor required to service the case while maintaining full displays.

A tray system for displaying produce was developed and tested. With this system, produce is prepared on trays in the backrooms and the entire tray inserted into the display counter. This system proved particularly effective for counter setup and takedown and improved the rotation of produce items. When produce rotation was unchanged, tray display saved from 1 to 3 1/3 minutes per case, depending on the item.

Advantages of tray display are:

1. Reduced handling of the product.
2. Better rotation.
3. Less congestion on the selling floor.
4. Neater sales area.
5. Flexibility of display location.
6. Better display planning.
7. Labor saving by fixed workplaces.
8. Equalized workload through advance preparation of displays.
9. Full displays maintained by clerks.

Rolling display bins, when properly constructed, were an effective display system for many produce items. The use of rolling display bins saved over half of the total handling time previously used for bagged potatoes. Proper construction of rolling bins involves:

1. A size small enough so they may be used exclusively for one item.
2. Nylon or hard rubber casters adequate to move a full load.
3. Swivel casters on front or back only.
4. Adjustable dummies in the bin to allow flexibility; preferably attached to the bin so they cannot be removed.
5. A shelf at the top of the bin which can be used for small items when displays are lower than the top.
6. The leading edges of the bins should be cut back enough to allow customers a full view of the product.

IMPROVED METHODS OF DISPLAYING AND HANDLING PRODUCE IN RETAIL FOOD STORES

By Dale L. Anderson and Paul F. Shaffer,
agricultural marketing specialists, and
Marvin D. Volz, industrial engineer,
Wholesaling and Retailing Research Branch,
Transportation and Facilities Research Division,
Agricultural Marketing Service

BACKGROUND AND PURPOSES OF THE STUDY

Retail produce departments usually account for 8 to 12 percent of retail food store sales. The labor-cost percentage in this department is one of the highest in the store. Much of this labor, in a bulk produce department, is used in displaying the produce and in materials-handling directly related to display work. Attractive produce displays add to the overall appearance of the store and create greater acceptability of the merchandise by the consumer.

The purpose of this study was to evaluate and develop improved produce display procedures. Detailed studies were made in several stores of 12 large corporate and voluntary retail food organizations. Numerous studies were conducted in other stores throughout the United States, and improved methods, procedures, and equipment were developed for handling produce in the backroom and display area. These improved procedures were installed in a number of stores, and detailed records were kept of production and yields. Comparisons were then made with conventional operations by means of time-study procedures.

FUNCTIONS PERFORMED IN DISPLAYING PRODUCE

In the conventional produce department, especially in an older or smaller store, most of the display work is done on the selling floor. The clerk brings several boxes of merchandise to the produce department, opens the boxes, sorts, trims, packages, and price-marks the produce; transfers it to the counter; and arranges it on the counter into a pleasing display. In this type of department, produce is often arranged in "pyramid" fashion, with each individual piece of produce being placed upon the display to form a neat geometric pattern. In such a department, practically all of the labor is performed on the floor in full view of the customer. Merchandise to be returned to the backroom, empty containers, trash, and other materials create considerable congestion and, in some cases, dangerous conditions.

In larger produce departments, a number of these functions are transferred to the produce backrooms. In the departments discussed in this publication, most of the trimming and practically all of the packaging were done in the backroom. The functions performed on the floor consisted of displaying the new merchandise; rotating the displays, pricing some items; building special displays;

opening, collapsing, and disposing of crates and boxes; fixing price signs or decorations; and cleaning the area.

Clerks and equipment tended to block customers' access to the displays and interfered with the flow of people between the counters, especially during peak sales periods.

In recent years, an increasing amount of prepackaged produce has been offered for sale in produce departments. Many produce items are prepackaged before they reach the retail store. Handling this type of merchandise is very similar to handling many bulk-produce items; boxes of packaged merchandise are brought to the selling floor, often priced individually, and then placed on the counter. In other stores, produce items are packaged in the store. These items are usually packaged or bagged and priced in the produce backroom area and brought to the display floor in a reusable tub or other container. The term "display," when used as a verb in this report, means transferring the merchandise to the counter. Usually, displaying involves individual pieces of produce, in contrast to other handling, which involves an entire container.

The amount of time spent in various functions for two bulk-produce departments and two prepackaged-produce departments is shown in table 1. The bulk-produce departments shown here had as much as 25 percent of the produce packaged in some form, while the prepackaged-produce departments sold some items in bulk form where unit pricing was possible. Produce department operations, including assembly, travel, display, rehandling, and policing, took about one-third of the total produce labor in the bulk stores, and about one-fourth in prepack stores. Rehandling includes taking any product off the display whether returned directly to the display as in rotation, or taken to the backroom for reconditioning or nighttime storage. Policing is straightening and rearranging the produce.

Table 1.--Breakdown of time by functions for two bulk produce and two prepack produce departments in retail food stores

Function	: Bulk departments		:Prepack departments	
	:Store A	:Store B	:Store C	: Store D
	:Percent	Percent	Percent	Percent
Receiving.....	2.9	4.2	4.2	2.4
Trimming.....	12.0	10.9	10.0	6.2
Packaging.....	10.9	8.5	31.5	30.2
Pricing.....	4.8	7.7	13.6	16.3
Assembly and travel.....	2.7	5.0	9.4	5.4
Displaying.....	16.7	20.2	7.6	7.1
Rehandling.....	8.9	6.0	4.9	3.7
Policing.....	4.2	2.4	5.7	6.4
Customer service.....	7.7	13.2	.3	1.2
Personal.....	5.3	5.3	5.5	8.2
Unavoidable delay <u>1/</u>	11.0	1.5	.9	2.9
Miscellaneous <u>2/</u>	12.9	15.1	6.4	10.0
Subtotal, all display functions....	32.5	33.6	27.6	22.6
Total.....	100.0	100.0	100.0	100.0

1/ Primarily due to lack of work at customer service scales. Includes some personal and break time.

2/ Includes assembly, travel, display, rehandling, and policing.

The greatest time losses in display work were caused by the use of poorly designed display cases, the absence of good materials-handling practices, and poor work methods. Store personnel often used scrap materials or packaging supplies to build "dummies" to improve the appearance of the display case, and much time was lost in building and maintaining these displays. Improper materials-handling methods also were found. Shopping carts and equipment from other departments were frequently used in transporting merchandise to the produce department selling area. Loads hauled were often small, requiring many trips to the backroom and coolers. Backrooms were often poorly designed or too far from the produce department selling area and caused extra travel. These improper work methods and the lack of adequate supervision resulted in the inefficient use of labor and materials, and caused the store personnel to work unnecessarily hard to accomplish their tasks.

Transferring New Merchandise to Display Counters

Transferring new merchandise to display counters has been a laborious hand operation. Some of the steps involved are inspection by sight or feel; grading by size or quality; separating the merchandise from the packing material; minor trimming work; unit pricing by various means; manual transportation of the merchandise, positioning or building of units into displays; and often decorating or building bases for the display case. When the varied handling operations are considered, together with the numerous possibilities for display arrangements, it becomes impractical to attempt to define one best display method for each item. Comparisons, however, were made of the relative productivity of the most common hand methods used to place merchandise on the counters. Time studies and observations of these methods form the basis for general principles for counter-stocking work.

Use of Hands in Displaying

Many clerks normally display produce by passing it from hand to hand. The use of both hands, each grasping and transporting merchandise from container to counter, is 25 percent more productive than passing merchandise from hand to hand, when one item per hand is handled (table 2). Where two, three, or even four pieces may be grasped by each hand and placed on the display, the use of both hands is even more productive, since it is difficult to transfer several pieces from one hand to another. Where each piece is positioned in a specific location on the counter, two hands working together, one piece in each hand, are most efficient. This permits the eyes to move with the hands and it improves the operator's ability to grasp the items properly and position them for maximum eye appeal. The two-handed method is particularly effective for trayed or bag produce under 5 pounds in weight per unit.

Two factors affect the time for hand methods of displaying produce--distance from the container to the display surface and use of both hands. There was a tendency for many produce clerks to park the stocking cart in the aisle and stand between the cart and the counter. Merchandise would then be passed hand-to-hand to the counter.

Clerks were taught: (1) To use both hands, moving together, holding one or two pieces of merchandise in each hand; (2) to park the produce handtruck as close as possible to the counter; and (3) to move the box being unloaded to a

proper working height on the end of the handtruck before beginning to fill the display.

The savings in time to place the merchandise on the counter using the improved methods ranged from 14 to 74 percent for various produce items (table 3).

Table 2.--Comparison in time per piece of various hand display methods for produce

Commodity	Hand-to-hand pass	2 hands - 1 each hand	2 hands - 2 each hand	Double handfuls
	Minutes	Minutes	Minutes	Minutes
Corn.....	.021	.015	.013	-
Bag carrots....	.024	.018	.018	<u>1/</u> .017
Radishes.....	.024	-	.018	<u>1/</u> .016
Lettuce.....	.022	.019	-	-
Escarole.....	.026	.022	-	-

1/ Applies only where placing is not required.

Table 3.--Display time per case for selected produce items, before and after training in improved display methods 1/

Item	Conventional	Improved	Savings
	Minutes	Minutes	Minutes : Percent
Peppers-bushel.....	3.10	2.10	1.00 : 32
Cucumbers-bushel.....	1.62	.94	.67 : 42
Carton tomatoes-box.....	1.57	.73	.84 : 54
String beans-hamper.....	4.67	1.22	3.45 : 74
Apples with wraps-box....	5.06	4.26	.80 : 16
Cherries-box.....	.98	.58	.41 : 41
Plums-box.....	2.25	.99	1.26 : 56
Grapes-box.....	2.37	1.08	1.29 : 54
Loose apples-field box...	2.02	1.41	.61 : 30
Bag carrots (48) paste-board box.....	1.15	.86	.29 : 25
Celery (30)-crate.....	.81	.60	.21 : 26
Corn-crate.....	1.26	.90	.36 : 29
Lettuce (iceberg) paste-board box.....	.53	.46	.07 : 14

1/ Methods used varied in each case. However, in the improved operation, most of the methods were those for which the operator was trained.

Types of Displays

Pyramiding displays, or individually placing each item on the counter, creates one of the highest labor costs in a produce department. The comparative times to build three types of displays is shown in table 4. In the first method, all the produce is individually placed in pyramids. In the second method, three rows of merchandise are pyramided at the front of the display, and the rest of the merchandise is placed to the rear of the counter, giving

a loose jumbled appearance. The third method results in a completely jumbled display. All merchandise is loosely placed on the counter. The times given in table 4 include placing merchandise on the counter, straightening the displays, and all rotating and policing of the displays.

Table 4.--Time per crate to display, and to police and rotate counter for size 88 oranges by three methods

Method	Per crate	Per 100 crates	Savings
	Minutes	Minutes	Minutes
Pyramid by hand.....	5.13	514	-
Loose by hand <u>1</u> /.....	3.69	370	144
Dump display.....	.49	50	464

1/ Pyramids for 3 front rows of merchandise.

"Dumping" as used in this report, means gently spreading the merchandise, without dropping it, from the tilted container to the counter. This is the preferred method for many different types of items, provided merchandise is firm and in uniformly good condition, and that the display space is wider than the container opening. Do not dump items which may receive damaging bruises. In determining what items may be dumped, the season and condition are often more important than the item. The worker must be physically capable of maintaining control of the container while it is being lifted over the edge of the counter and the contents released. The container should be lowered carefully over the display space, and one hand should control the rate of flow and the dispersion of the merchandise over the area of the display. When dumping items that roll easily, such as apples and citrus fruit, onto a counter that has a shallow front retaining edge, it may be preferable to pyramid the front two or three rows. When the display is piled too high, dumping is impractical for items that will roll. Attempting to pile displays to great heights results in spilled merchandise and unstable displays. Also, the bruising suffered by pieces that fall to the floor adds to shrinkage. The elapsed time to load merchandise on the counter in a jumbled display using dump and hand methods is shown in table 5. Dumping took one-third to one-half as much time as hand displaying.

While jumbled displays could not be piled as high as pyramid displays, the time to refill them was so much less that fuller displays could be maintained throughout the selling period. Thus jumbled displays were the more effective for merchandising, as well as providing a lower labor cost.

A significant factor in cost of labor for displaying is the height of the display. When displays are built above a certain height, the time required to fill and maintain them mounts rapidly. Figure 1 shows the effect of heights of display on the time required to build and maintain these displays by hand and dump methods. Display time for the first six boxes added to the display counter is about the same, but the time rises rapidly for the seventh and eighth boxes, due partly to the hand stacking necessary to keep the merchandise on the counter. Since displays are usually replenished before they are completely empty, we can assume that this display would be refilled when half full. The operator who refilled this display to the eighth case level each time would spend nearly twice as much time to hand-fill and four times as much to dump-fill this display as the operator who filled it to the six-box level.

Table 5.--Comparison of time to display one box of certain produce items by hand transfer and by dumping

Method <u>1/</u>	: Size 100 : oranges	: Size 126 : oranges	: Size 150 : lemons	: Bulk : apples
	: <u>Minutes</u>	: <u>Minutes</u>	: <u>Minutes</u>	: <u>Minutes</u>
Dump on counter.....	: .17	: .26	: .13	: .17
Straighten display.....	: .46	: .33	: .47	: .34
Total.....	: .63	: .59	: .60	: .51
	:	:	:	:
Total-Unloading by hand..	: 1.18	: 1.88	: 1.31	: 1.54

1/ Resulting displays were jumbled with comparable appearance, height, and depth.

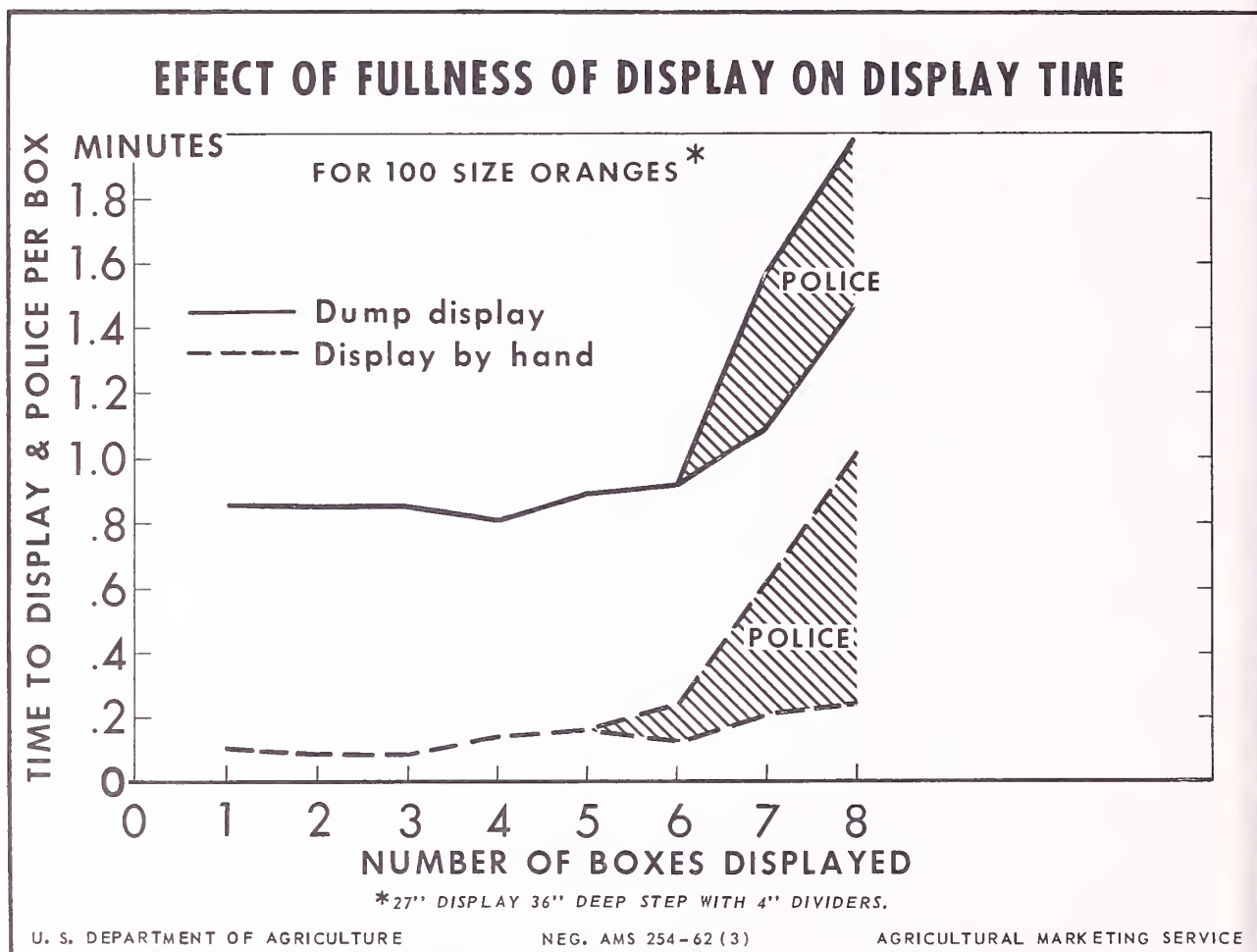

Figure 1.

Price-Marking on the Sales Floor

When items are price-marked or coded at the time that they are placed on counters, the most common method, for large items, is to pick up the item in the left hand, bring it against the body and price-mark it with an indelible pencil with the right hand. The item is then placed on the counter with the left hand. This is a slow process. Two hands can be advantageously used with some products, by price-marking a layer of produce in the container and then placing it on the counter. When grading is done, a layer of the product can be placed on the counter with both hands and then priced. Multi-impression stick stamps or adhesive labels can be used for many items and are faster than using an indelible pencil. The fastest method was to code the item either with a stamp or with a single or double pencil mark to identify the item to the cashiers. It is necessary to have a code chart at the checkout counter to follow this system. One effective marking code method is to use no marks for the item with the highest price, one for the next price, and two for the next. When this method is used, the price of the produce can be changed as necessary, simply by adding a mark.

Rotation of Produce Displays

Because of the relatively short shelf life and of the variation in quality that occurs within one lot or container, produce on display must be rotated and sorted regularly. These same factors cause the customer to do more handling of produce in selecting the items she wishes to purchase, and increase the need for straightening of the displays. Though packaging reduces the handling of merchandise, customers still tend to inspect more packages before making a selection than they do when selecting more uniform products such as grocery, dairy, or frozen-food items. As a result, produce is often handled several times after it is placed on display.

Much produce is removed from the display and returned to the backrooms for reconditioning, repackaging, or for nighttime storage in a refrigerator. When this is done depends on whether the department handles prepackaged produce, uses display cases with mechanical refrigeration, or has bulk produce on icebeds.

The percentages of rehandled items for bulk and prepackaged produce are shown in table 6. The product rehandled is shown as a percentage of that sold. For all produce handled, this varied from 8 to 25 percent for 10 stores. The rehandling represents a considerable amount of labor spent on the product beyond that required to place it on sale the first time.

Rotation of produce as it is displayed involves removal of old merchandise, and sorting and placing it on top of the display after new merchandise has been placed on the counter.

In test stores, a thorough rotation required one-third to two-thirds as much time as was spent placing new stock on the counter. Type of item, condition, rate of sale, and the overall quality determine the extent of rotation. Hardy fruits were rotated twice a week in most stores. Bagged items with code identification were usually rotated daily or each time new stock was added. A partial rotation for bulk displays of hardy fruits was often practiced; old merchandise was moved to the front, and a close inspection made of the fruit;

Table 6.--Produce rehandled as a percentage of sales in three produce departments for selected items and total items

Item	Store A	Store B	Store C
	Bulk produce on icebed and dry racks. Takedown at night	Prepackaged produce on icebed and dry rack. Takedown at night	Prepackaged produce; mechanical refrigerator and dry rack. No takedown.
	Percent	Percent	Percent
Iceberg lettuce.....	17.0	21.0	32.7
Romaine lettuce.....	70.0	98.7	27.8
String beans.....	82.7	4.5	10.0
Cucumbers.....	4.3	11.0	2.7
Grapes (fast movers):	6.3	4.6	5.3
Grapes (slow movers):	60.7	32.8	-
Apples.....	14.3	5.7	1.6
Lemons.....	30.6	11.5	2.6
Oranges.....	10.2	8.5	4.1
Bananas.....	<u>1</u> / 0	4.3	3.2
Tomatoes (bulk).....	<u>1</u> / 0	9.0	<u>1</u> / 0
Sweetpotatoes.....	24.4	72.4	10.0
Average-- all commodities...	16.7	21.9	7.8

1/ None returned to display.

then new merchandise was stocked at the rear of the counter. Soft fruits and trimmed salad items received complete rotation each time merchandise was stocked

Shopping carts were often used for rotation. The produce was removed from the counter to the cart, new merchandise placed on the counter, and the old produce inspected and returned to the top of the display piece by piece.

Straightening of displays, or "policing," is another form of merchandise handling in which the clerk merely rearranges the display and possibly sorts the merchandise. Often the clerk may spend only a few seconds on each individual display, moving rapidly down the counter to improve the appearance of the entire department by straightening the positions of produce.

In addition to rotating, policing, and rehandling, time was often spent preparing produce items for sale at reduced prices. This was often more than a price markdown, because frequently the product was packaged or presented in a different form. Sometimes a "reduced for quick sale" price tag was added.

Table 7 shows the times required for the various display functions per case of new merchandise for a selected group of commodities in one store. The times vary with the perishability and the rate of turnover of the various products. For this store, original display represented only 40 percent of the total handling of individual items of produce at the display case. These times exclude travel and handling time from backroom to the display area.

Table 7.--Time for handling the individual item per case sold in a bulk-produce department 1/

Selected items	: Display- : ing new : merchan- : dise	: Redisplay- : ing old : merchan- : dise	: Rotating : or : moving : displays	: Policing : and : straight- : ening : displays	: Handling: : reduced: : merchan- : dise	: Percent: : rehan- : dled	: Total
	: <u>Min.</u>	: <u>Min.</u>	: <u>Min.</u>	: <u>Min.</u>	: <u>Min.</u>	: <u>Pct.</u>	: <u>Min.</u>
Iceberg lettuce.....	1.08	.31	.21	.29	.22	23.1	2.11
Corn.....	1.74	.36	.12	-	.30	11.1	2.52
String beans..	.36	.32	.14	.27	-	30.2	1.09
Cucumbers....	.86	.09	.29	.91	.21	8.9	2.36
Apples, with wraps.....	4.16	.05	2.46	.35	.11	2.9	7.13
Grapes, seedless....	2.33	.04	.47	.33	.40	1.2	3.57
Grapes, Tokay.....	2.72	.36	2.95	.29	.41	12.7	6.73
Packaged salad.....	.95	.19	.13	.20	.47	34.0	1.94
Cello carrots:	1.39	.10	.19	.19	-	6.0	1.87
5-lb. bag potatoes....	.61	-	.06	.15	.18	0	1.00
Store average: (all commodities)	1.31	.44	.63	.42	.53	18.0	3.33

1/ Includes only the handling of individual pieces of produce--not the handling of full cases.

The exact location on the display rack from which customers select the items is one aspect that affects rotation. If there is an obvious difference in quality of old and new merchandise, no placement of rotated merchandise will prevent customers from digging under to get the better grade. However, when merchandise was all of good quality, most items were selected from the center section of the counter (table 8). Location of sales was measured by observing the spot in the case from which the purchases were selected. The case was divided from the front to back into 1-foot sections. When extensions were added to the front of the case, these were measured as the first 18 inches. The quantity and condition of the merchandise affected the location of sales to some degree.

When the orange display was low, much heavier sales occurred in the back section of the case than when the display was full. (Note that from one-third to two-thirds of the items picked up were returned to the display.)

The amount on display at the time the counters are refilled affects rotation time. Obviously, the more produce remaining on display, the more must be moved to add new merchandise. This also depends on the space an item is given in relation to its sales.

Table 8.--Location of item sales according to selection point on the display case

Item		Selections	Returns
		<u>Number</u>	<u>Number</u>
Bulk peas -	1st 12 inches.....	27	-
	2nd 12 inches.....	55	-
	3rd 12 inches.....	24	-
Oranges - (Min. depth of display)	1st 18 inches.....	13	8
	2nd 12 inches.....	58	19
	3rd 12 inches.....	57	18
	4th 12 inches.....	33	5
Oranges <u>1</u> / (Well-filled display)	1st 18 inches.....	33	11
	2nd 12 inches.....	64	22
	3rd 12 inches.....	46	19
	4th 12 inches.....	13	3
Grapefruit - (Medium-full display)	1st 18 inches.....	13	10
	2nd 12 inches.....	25	15
	3rd 12 inches.....	13	8
	4th 12 inches.....	3	0

1/ These displays had about a 6-inch pyramided front.

The type of display case also affected rotation time. Cases with deep recesses or glass fronts create pockets of merchandise not available to the customer and these need to be rotated on a regular basis.

The most effective hand-method rotation system was to remove the old merchandise to a tub or basket on the handtruck. The handtruck with the container was parked next to the display and all old merchandise removed from the counter by hand and placed in the container. The counter base was then cleaned and new merchandise was placed or dumped on the counter. The old merchandise was then sorted and returned to the center of the display. Sorting was done either when removing the merchandise or when replacing it, and any off-quality merchandise to be sold at reduced prices was set aside when sorted. In the case of bagged or packaged merchandise, the packages containing any spoiled or off-quality merchandise were opened and their contents removed. Items to be repackaged were placed in a container to be returned to the packaging line.

In some stores, the use of counter liners increased efficiency in rotation. Counter liners are pans which can be lifted out of the case to eliminate individual handling in rotation.

The following general rules to reduce rehandling of produce items were developed.

1. Relate display-space size to expected sales and condition of produce.
2. Avoid display fixtures with deep recesses.
3. Rotate when needed and only then.
4. Keep displays separate when different lots of a given product vary in quality, size, or condition. Don't mix quality.
5. Keep quantities low early in the week.
6. Refill displays when they hold the minimum quantity that will still cover the display bases.
7. Use counter liners where possible.

Handling Shipping Containers

Produce shipping containers and boxes create a problem on the sales floor if not properly handled. Some clerks simply drop the boxes, as they are emptied, on the floor by the display counters, and pick them up later, creating an unsightly and dangerous situation for the customers. Preferably, containers should be cleaned, nested, or collapsed and stored on the work cart out of the way.

Opening nailed containers requires a tool for prying and hammering down the extra nail heads. Many clerks use an 8-ounce opener which is easy to carry in the pocket. Generally, clerks agreed that the heavier 14-ounce opener was superior for opening crates. An adequate tool rack on the cart handle eliminates the need to carry this tool in the pocket.

Wirebound crates can be difficult to open with the fingers. Several economical tools are available for this purpose (fig. 2). A short piece of half-inch pipe flattened on each end to form an oval makes a good opener. The pipe is slipped over the end of the wire to bend it upward. A small hook with a handle can also be used. The operator hooks the end of each loop and pulls to straighten the wire. When wirebound crates are to be collapsed, it is advantageous also to remove the end loops when opening the box. Then when the box is empty, it can be collapsed by pushing in the ends and folding the box.

Most corrugated fiber containers can be opened by pulling the flaps. When they are empty, the bottom flaps can also be pulled and the carton folded flat.

Citrus-fruit cartons are somewhat heavier and more difficult to collapse. The easiest method of collapsing these cartons is to raise the top slightly and cut around three sides near the top with a case cutter. The carton can then be emptied without separating the two parts of the box. When empty, the box is turned over and the bottom slipped up slightly and cut the same way on three sides (fig. 3). The box can then be collapsed and stored. Some clerks cut a criss-cross on the base of the box through the two layers of cardboard, but a problem occurred when staples were used in constructing the box; they often nicked the cutter blade.

Miscellaneous Tasks Performed on the Selling Floor

Several other jobs on the selling floor performed by display personnel are setting up and changing price signs; building and adding to special displays; putting up promotional materials; cleaning floors and cases, taking care of special departments, such as plants and flowers, or garden materials;

and helping customers. These jobs usually take little time, but a considerable amount of time may be lost in performing them if the materials and tools are not organized.

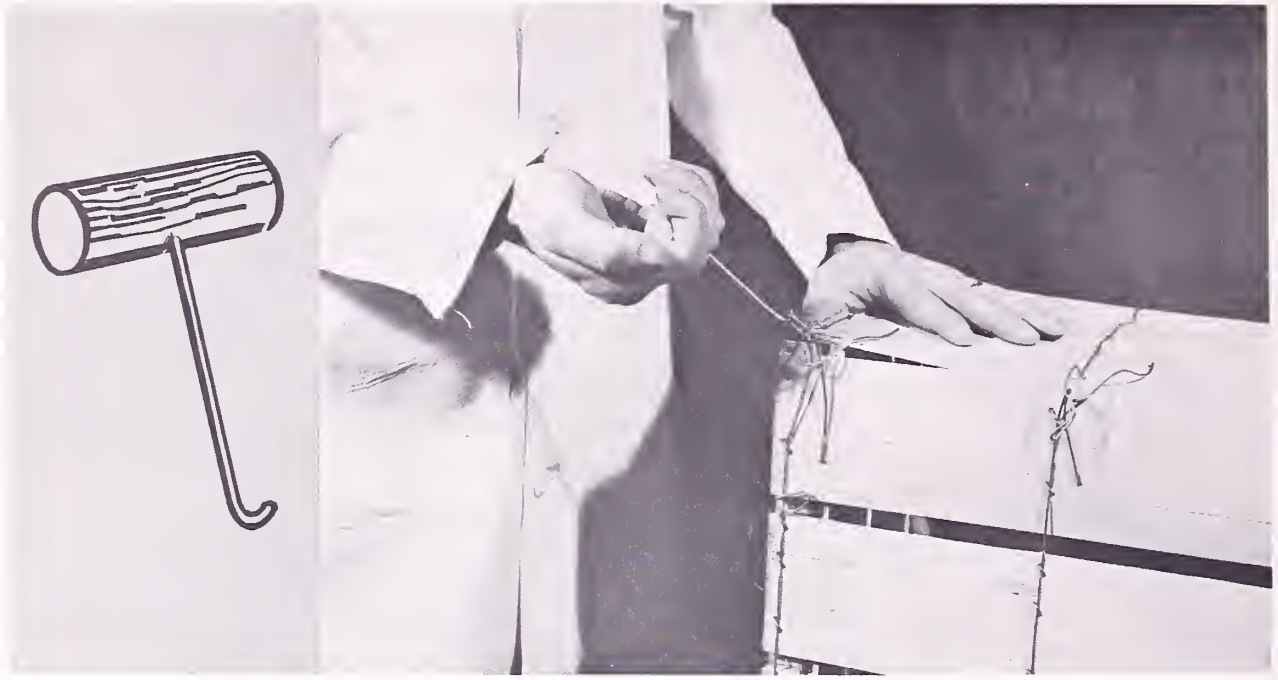

Hook for pulling wires.

BN-16038

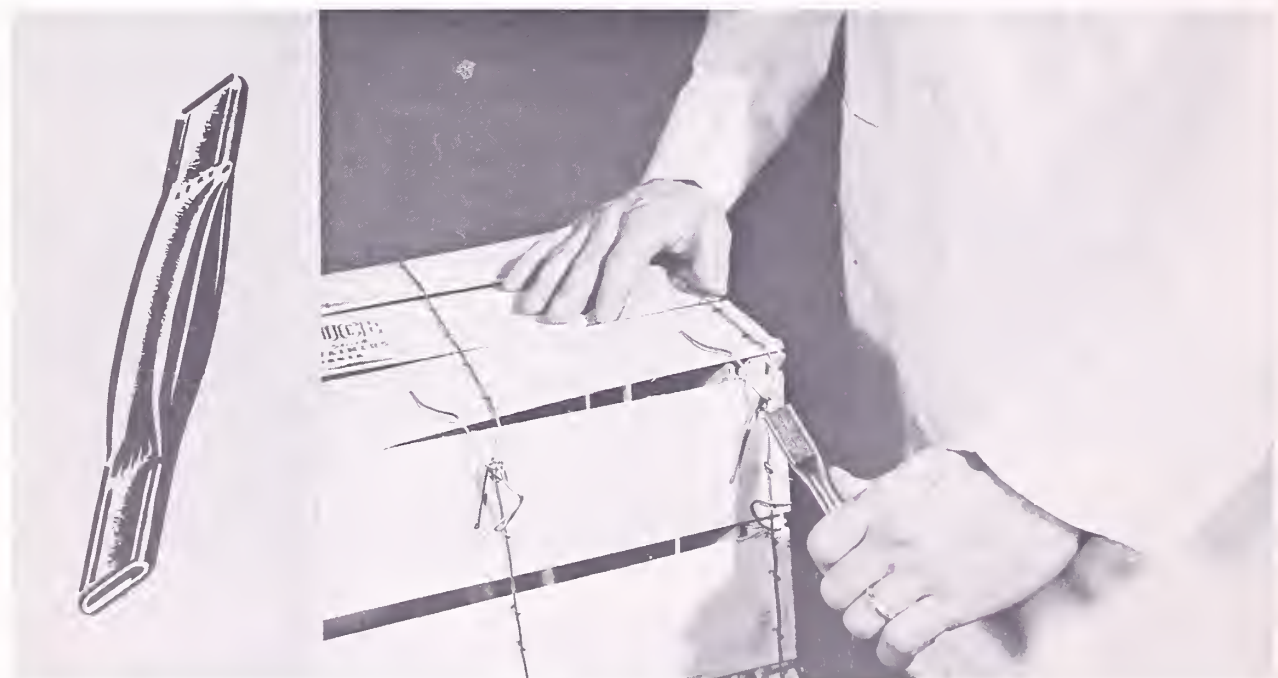

Flattened pipe for bending wires.

BN-16040

Figure 2.--Two styles of openers used to open wirebound boxes in produce departments.



BN-16041
Operator cuts three sides and folds open the top.



BN-16042
Operator slips top up slightly and cuts three sides of bottom.



BN-16044

Box collapses for easy storage.

Figure 3.--Method of cutting and collapsing a fiberboard citrus carton without separating the two parts of the box.

Price signs should be stored in partitioned bins at the display area or on mobile carts to reduce travel time.

Mounting special promotional exhibits and decorations requires a certain amount of artistic skill, and most store employees take great pride in their abilities to develop such artistic displays. However, some materials and tools are necessary if the end result is to be attractive. A stock of small boards and staple-guns, tape, shelf extenders, and other material should be maintained for this purpose. Also, a set of general rules should be developed to specify how, where, and what kinds of display are desired by the company, because poor location of special displays can detract from overall sales (3). 1/

Takedown

The function of "taking down" merchandise from the display counter is performed in varying degrees in most supermarkets. Some stores, especially those using icebeds, remove all perishable produce from the counter each night and remove all produce on the weekend. Other stores remove only selected items at night, while some stores cover the displays at night and rework the merchandise at the case the next morning.

The process of stripping the counter at night, if properly organized, can be a simple one, and usually produce will be of better quality if the merchandise is taken down and properly stored in the coolers during the night and reworked in the morning (4). A set of stacking and nesting tubs and some low handtrucks to carry them constitute the primary equipment necessary for this function.

The display case should be policed before closing to ascertain the quantity and quality of the merchandise and to remove any that should be thrown away. After store closing, items should be taken from the case and stacked in tubs. Produce should be stacked vertically in the tub (not in layers) so that each item is visible. Merchandise to be retrimmed should be kept apart from items that can be returned directly to the display, and in separate tubs on a separate truck. In large stores, the most effective takedown procedure was for the operator to go twice through the department, removing produce to be reworked on one trip and produce not requiring reworking on the next trip. The loaded carts were then parked in the coolers and the cases and floor cleaned in preparation for the next day.

The Materials-Handling Task in Produce Display Work

In two test stores, over 30 percent of the time spent on display work was spent in obtaining and moving merchandise from backroom to selling floor. During a typical week, in a produce department with weekly sales of \$4,000, employees moved 29,000 pounds of merchandise from the backroom to the selling floor. Counting all the handlings, a full-time employee handled 45,000 to 60,000 pounds of merchandise and packing material each week.

1/ Underlined figures in parentheses refer to Literature Cited, p. 48.

Selecting Merchandise and Loading for Display

In the normal cycle of display, the clerk determines the items needed at the display counter, goes to the backroom, loads the items that are available, and orders from the trimming or processing line those not available. The time to obtain merchandise varied according to the arrangement of the backroom storage areas. Produce should be displayed according to the length of time it has been on hand and its condition. Orderly storage with proper coding of commodities according to date received facilitates handling.

The methods of receiving produce usually had the greatest effect on accessibility (5). The most effective overall method was to receive and store the delivery load on semilive skids or pallets which were parked on one wall of the cooler or storage area. Space was left between skids for "breakdown" -- when merchandise is left on skids, some pieces must be set aside to get other desired items. At the end of each day or just before the next delivery, the remaining merchandise on skids is removed, coded, and stored on another wall. Merchandise to be trimmed for the morning counter setup or packaged early in the day, can be consolidated on a separate skid. When selecting merchandise to display the display clerk first checks the older merchandise area and then the new load.

As much production work as possible should be done in the backrooms in advance of display needs (6). The citrus fruit coder can be used advantageously to price-code bulk citrus fruit in advance of storage and thus reduce the labor required on the floor. It was also found advantageous to remove lids in the backroom before moving to the sales floor.

Transporting Merchandise to the Display

While several types of carts may be used to move produce to the display, the efficiency of the operation depends primarily on the number of pieces taken per trip. Two-deck stocking trucks equipped with tool shelves may be used most efficiently where little backroom packaging is done (fig. 4A). The top deck should be at a comfortable working height when merchandise is correctly positioned on it. These trucks should have a low second deck, 24 inches from the floor, to hold empty containers. Carts can be built with "Y" handles for holding the box at the correct angle during unloading (fig. 4B). During slack periods, skids or pallets may be pulled to the floor, if they can be parked out of the way of customers. Lowboy and highboy dollies of various kinds work well for trayed or packaged produce. Highboys that were found to be most efficient were those with open-end loading which allowed the operator to reach the pan or the merchandise conveniently. Also, they allowed easy removal of the pan from the highboy without spilling or damaging produce (fig. 4D). Standard highboy carriers often damage merchandise, when pans are placed in the racks, because merchandise hanging over the side of the pan hits the support posts.

Shopping carts should not be used to transport merchandise to the produce department because: (1) They can carry only small loads; (2) they often damage the merchandise; (3) the produce causes deterioration of the cart's finish, and (4) shopping carts require too much space in relation to the load. Another inefficient system was the use of the lowboy tub holder (fig. 4C), which was difficult to reach into, and provided none of the advantages of nesting tubs or double-deck carts.

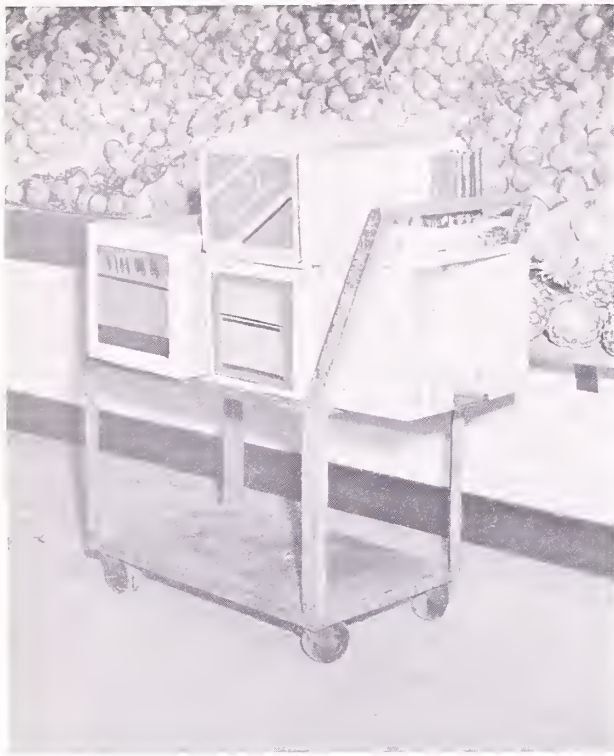

A. Two-deck cart.

BN-16043

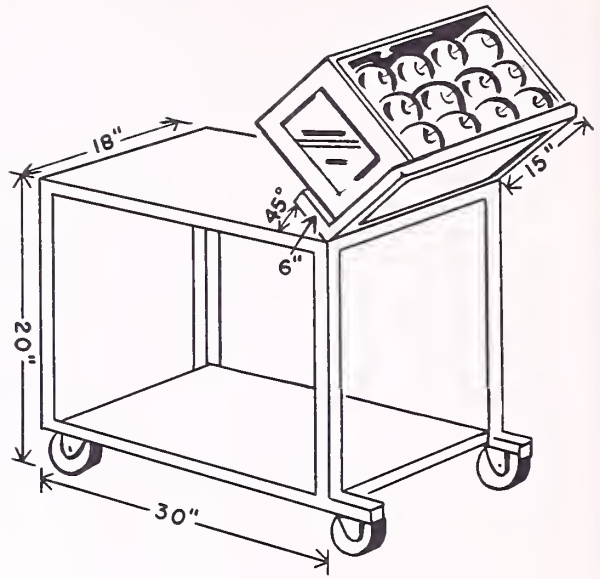

B. "Y"-handle cart.

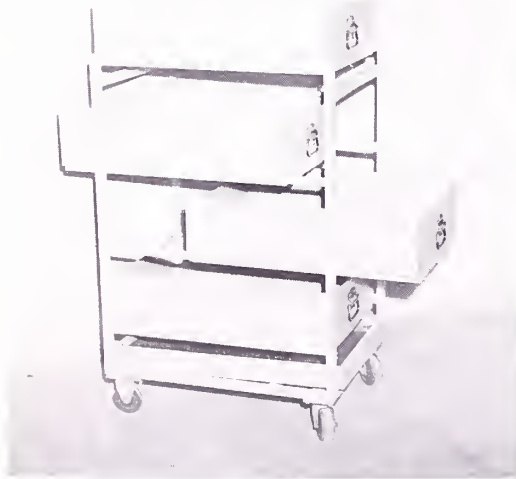

C. Lowboy tub holder.

BN-16034



D. Open-end highboy carrier.

BN-16035

Figure 4.--Types of stocking carts used in displaying produce.

WORK PLANNING BY THE PRODUCE DEPARTMENT MANAGER AND PERSONNEL

The ability of the department manager to develop an effective advance plan for each day's workload was a key factor in realizing a gain in productivity from improved display work procedures. Appreciable total time savings that can be translated into a more effective merchandising effort, or a lower payroll cost, are dependent upon combining the savings realized from many separate and varied operations. The activities of display workers range over the entire department and are of short duration, ranging from a few seconds to less than 10 minutes. Test-store experience indicated that time savings in one area of work were easily dissipated by duplication of work or inefficient performance in some other area. Usually, these time losses were due to poor planning or the failure to keep employees informed of circumstances affecting their area of work responsibility.

The work of managing was usually concentrated in the following areas: (a) Ordering, inventory, and keeping records (1); (b) developing a schedule of working hours for produce department help (1); (c) planning space allotment, location, color contrast, methods of stacking or packaging, and sizes of the various displays, including form, location, and construction of "special" displays; and (d) instructing employees in stocking counters and in backroom production (2). Management functions discussed here will be those relating to display work.

Planning Counter Arrangement

Planning the arrangement of merchandise on a counter and the width of each display was accomplished in several ways.

The experienced department manager usually developed a practiced eye in making space assignments. Recollection of the previous setup, aided by the item markers in the price strip, construction joints, and other random benchmarks in the counter surface, can serve as guidepoints for determining the location and width of the areas to be occupied by produce items.

The most common method observed for resetting wet-rack divider strips at desired space intervals was to place enough pieces of merchandise on the counter to fill out the front row of each display and then position the divider strip. Space determination by this method requires that a quantity of each item be at hand before display work is begun.

Another approach to wet-rack-item spacing was to start with the first item at one end of the counter and add adjacent items in sequence. The worker usually remembered the number of rows of each item customarily displayed. This is satisfactory only when there are no major changes in space allocation or changes in work routine. Very often, near the end of the counter, adjustments were required because of an error in judgment, which added considerable labor to the task.

In many stores, minor changes in space allocation were required nearly every day, because of the daily changes in the variety, quality, and quantity of items received in the produce delivery. There were frequent omissions or

additions of items to the daily produce delivery. Store personnel were not told of these items until the truck arrived or until the central-office instruction sheet was received.

Until all counters were completely set up, the display arrangement existed only as a mental picture for the department manager and his assistants. The manager was obliged to create a display from memory, giving due consideration to: The variety of items to be stocked; the size of all display counters and stands; the color contrast desired; the grouping of similar items; the traffic-pulling influence of certain items; and the instructions received from superiors regarding special displays. As a result, workers tended to pause frequently while setting up new displays, continuously checking by eye and attempting to estimate whether the counter, when fully stocked, would be spaced and balanced in accordance with the instructions given by the manager. The worker was obliged to confer frequently with the manager to determine whether his work correctly followed the manager's instructions. Counter display work often was delayed until all items were at hand, so that each could be set on the counter in sequence, rather than beginning with whatever items were immediately available. This resulted in loss of time for display workers while waiting for backroom processing to be completed or, perhaps, for items to be received in the morning delivery.

The first step in installing a systematic procedure for space planning is division of counters into numbered space units.

To determine the width of displays most commonly used, measurements were made in stores of several firms. These measurements showed there were several common widths used for displays. The widths tended to be multiples of 7, 8, or 9 inches.

There was a marked tendency to hold display widths to two or three sizes and to keep an equal width on displays of similar sizes as a means of balancing the eye appeal of the counters. Therefore, in planning displays, the "common denominator" width should be determined and marked on the counter. For example, "red radishes, two widths; celery, four; and spinach, three," would indicate, with a common denominator width of 8 inches, a width of 16 inches for red radishes, 32 inches for celery and 24 inches for spinach. Sketching out such a plan on paper permits the adjustment of spaces without moving the merchandise, and serves as a written order to the clerks. A display layout guide based on this principle, for use in a department with a multiple of 9 inches as a common denominator, is shown in figure 5.

Tray display offers a system for planning space for produce based on the number of trays or baskets used; this greatly simplifies the planning process (fig. 5). The desired tray space can be marked on the counter and these slots filled with combinations of half or whole trays.

Organizing Produce Display Work to Reduce Travel

The operations performed on the selling floor are varied, but most operators follow a normal work cycle. This cycle consists of obtaining the merchandise; loading it on a stocking cart; moving it to the selling floor; displaying and rotating the items; and then returning to the backroom with salvage, trash and off-grade merchandise. These byproducts are disposed of and the cycle repeated.

Tray display with mobile potato bins

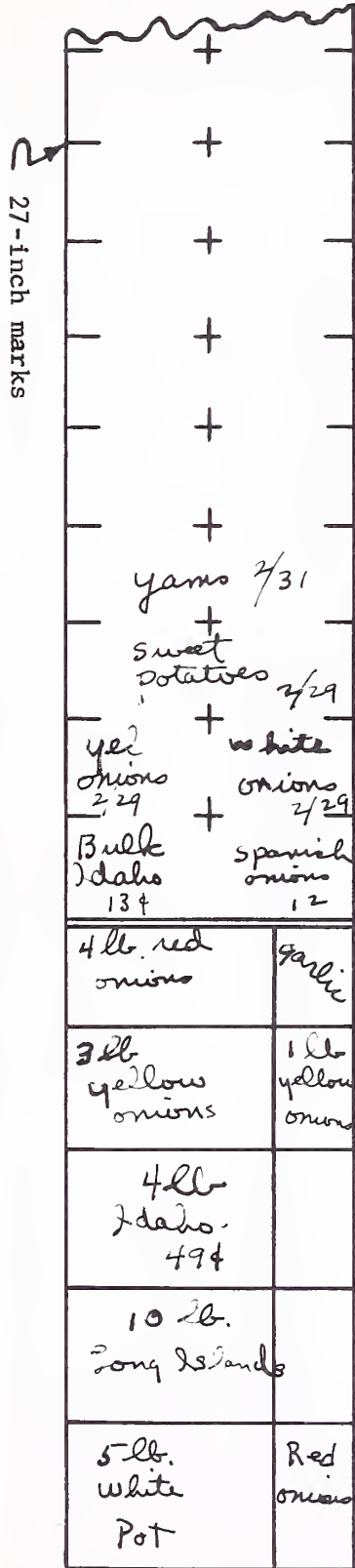

Conventional displays

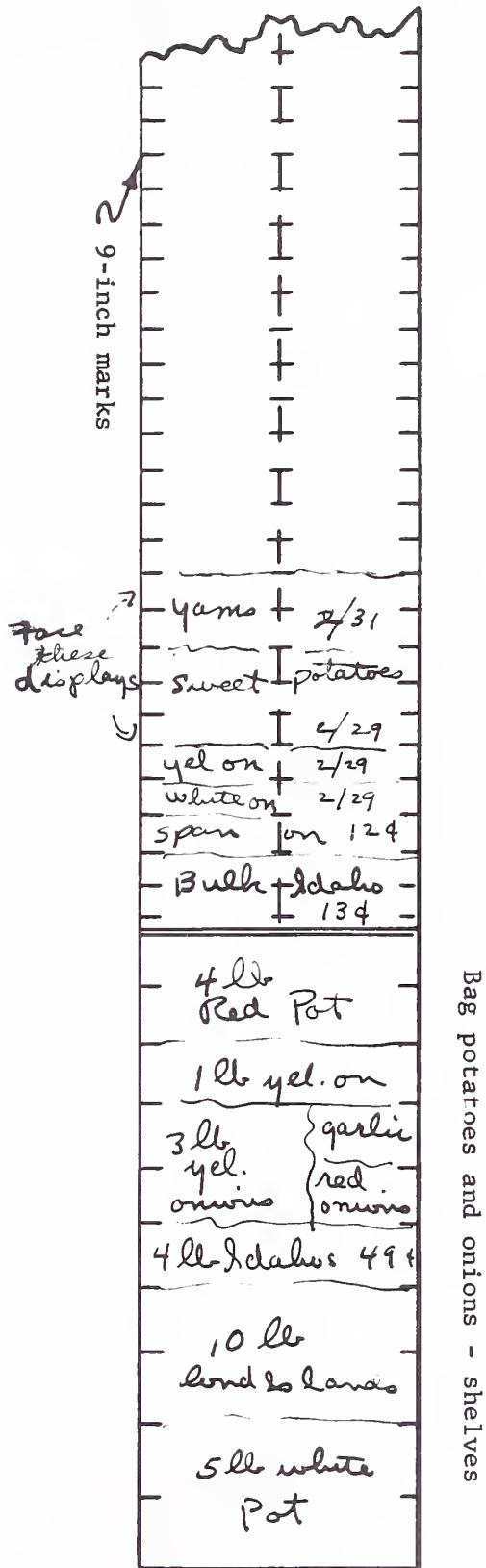

Figure 5.--Layout guides used to plan location of various produce items on the display case. The layout is filled in in pencil as it would be in actual use.

Study of display work patterns in produce departments showed that produce employees habitually worked on only two or three items in each counter stocking cycle. This was characteristic of the work pattern in both morning setup and routine restocking throughout the day. The movement of merchandise from backroom storage and preparation areas is heavily concentrated in the morning setup period--7 to 11 a.m. This period afforded the greatest opportunity for deriving maximum benefit from improved handling procedures.

A typical display cycle in one store is shown in figure 6A. Clerks transported small loads and performed unnecessary travel to obtain tools and materials

The most efficient display cycle minimizes the extra travel between selling floor and backrooms. Merchandise needs are determined in advance, and loads are selected so that the operator makes a minimum number of trips. The merchandise is loaded so that a logical path can be followed through the produce department. All necessary tools and supplies are carried on the cart, and trash and salvage are nested and stacked on the cart. Markdowns and merchandise needing reworking are taken care of on the return trip; salvage, trash, and garbage are disposed of on entry to the backrooms.

Convenient temporary storage for salvage, trash, and garbage should be provided so that clerks will be encouraged to dispose of these items as they enter the backrooms. In a prepack operation, it may be of prime importance to locate trash disposal near the production line. There should be adequate storage place for unused carts. Prepack trays and trim tubs should have a storage location beyond the trash and salvage so that these items are returned to the production area.

In test stores, the produce manager was asked to spend a few minutes each morning reviewing the total workload of his department for that day. In devising improvements for counter stocking work, an effort was made to have each cycle of work carefully planned by the worker before leaving the backroom. Clerks were furnished with small notepads and asked to write down the items, varieties, and quantities that should be stocked next. This same list was used to give instructions to the trimmer and other personnel engaged in backroom preparation work and in assembling merchandise on the handtruck. The worker was encouraged to load the truck with a view to unloading; that is, the sequence in which merchandise would be displayed.

When assembly of merchandise was completed, the clerk reviewed display requirements for each item on his cart to determine: (1) The tools, supplies, and price-marking equipment that would be needed; (2) the current prices, from the daily price sheet posted on the cooler door; and (3) any pertinent special instruction given in the daily information sheet.

A major objective in the improvement of work performed in the sales area was to establish at the counter continuous work sequences of 30 to 50 minutes' duration for the morning setup period, and 15 to 20 minutes for routine restocking operations. Figure 6B shows an optimum display cycle for the test store after improved display methods had been adopted.

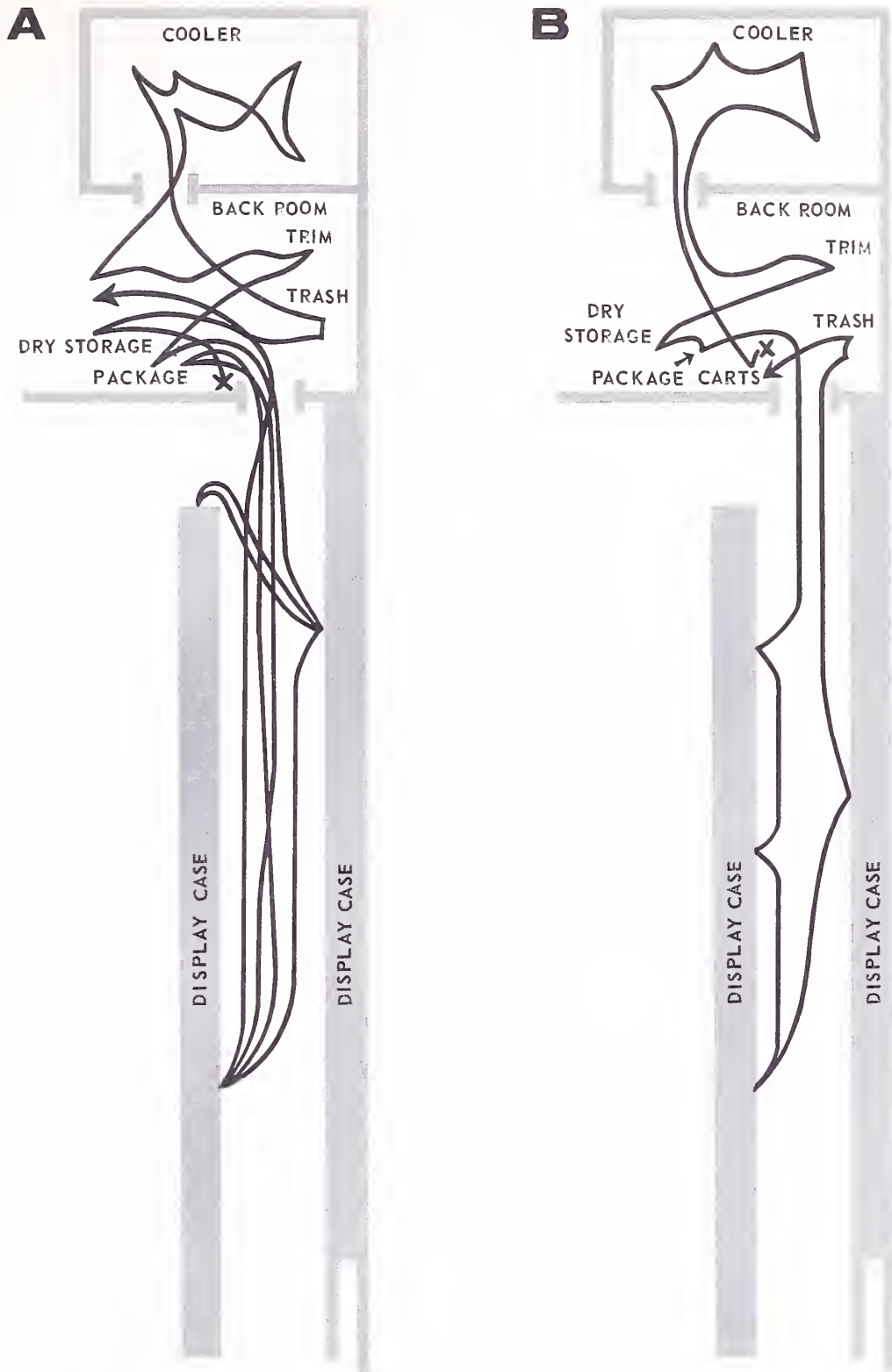

A. Typical display work cycle.

B. Improved work cycle.

Figure 6.--Work cycles covering the travel used to place one cart-load of merchandise on the display case.

In the improved operation, by transporting more cases per trip, and anticipating sales so that the displays were refilled prior to need, approximately one-fourth of the previous time for this operation was saved. Studies of the conventional pattern of counter stocking work in two of the test stores showed that an average of 2.1 and 2.7 master containers were brought to the counter on each trip. This average was raised to 3.4 and 4.7 cases per trip by using the improved procedures. Interruptions caused by lack of adequate equipment and pricing information were practically eliminated. In addition, more time was spent in rotating and merchandising, and the quality of the produce and the display appearance were greatly improved. Test-store measurement of travel time for the display function showed that this time could be reduced as much as 45 percent, or about 1/3 minute per container (table 9).

Table 9.--Improvements in travel time for displaying produce in 2 stores

Period	Store A		Store B	
	Average cases	Travel time	Average cases	Travel time
	per trip	per case	per trip	per case
	Cases	Minute	Cases	Minute
Before training.....	2.70	0.781	2.11	0.568
After training.....	4.72	.426	3.39	.445
Savings.....		.355		.123

Equalizing the Display Workload

Normally, the rate of produce shopping is heaviest on weekends and during certain periods of the day, but work schedules often cannot be adjusted to fit this sales pattern. A good produce manager will add merchandise to his displays in advance of peak selling periods. This enables him to schedule his assistants work more evenly, or "equalize." This advance preparation of displays also has the advantage of reducing the number of clerks, carts, and other paraphernalia on the selling floor during peak periods. An even workload schedule not only reduced labor cost, but also reduced out-of-stock conditions. Practices which were found to be of the greatest help in equalizing the display workload were:

1. Rotate and load displays before expected peak sales period.
2. Do as much work as possible before the expected peak sales period (such as premarking citrus fruit, packaging, pricing, and trimming).
3. Prepare ahead of time the loads of merchandise which will be needed at the displays.
4. Work the items on the dry counters in the evening so that wet and perishable items can be worked exclusively early in the next morning.
5. Work on bulky items which tend to create congestion on the floor during slack periods.
6. Provide written work assignments for employees' guidance, particularly during slack periods and evenings.

GENERAL PRINCIPLES FOR DISPLAY WORK

Keys to effective work are: (1) Transport adequate loads to the produce department sales area to reduce the total number of trips; (2) have on the

vehicle all the tools and supplies necessary to do the job, to reduce travel time; and (3) use effective methods of transferring and rotating the merchandise. The following principles express most of the best methods employed in various display procedures:

1. Plan the work ahead.
2. Do as much work as possible in the backroom.
3. Take a large load to the counters and plan an efficient work cycle.
4. Carry necessary tools and supplies on the vehicle.
5. Park the cart close to the display.
6. Position the box of produce close to the body of the handler.
7. Use both hands to transfer merchandise.
8. Use dump or loose displays where possible.
9. Place an entire container with its contents on the counter where possible.
10. Keep merchandise displays at reasonable heights.
11. Follow an orderly path at the counter.
12. Use containers that nest and stack.
13. Get rid of garbage, trash, and salvage as they accumulate.

These principles were taught to the produce department personnel of two bulk-produce departments. The results of applying these improved work methods are shown in table 10, with "before" and "after" time studies of the display functions performed. The labor savings for these two stores, which averaged \$3,000 to \$3,500 a week in produce sales, was 23 and 28 percent. This amounted to about 26 to 30 hours per 1,000 cases handled.

Table 10.--Average time per container to perform bulk produce display work before and after training in improved methods

Activity	Store A		Store B	
	Before	After	Before	After
	Minutes	Minutes	Minutes	Minutes
Select and load merchandise for display.....	.35	.21	.32	.20
Obtain materials and equipment.....	.29	.10	.23	.19
Other backroom handling.....	.01	-	.12	.09
All display travel.....	1.04	.50	.52	.46
Display and price.....	1.92	1.38	1.32	1.05
Rotate, rearrange, police.....	.51	.65	1.05	.59
Open containers.....	.23	.20	.12	.12
Redisplay.....	.82	.53	.44	.23
Handle distress produce.....	.02	.03	.53	.16
Other display handling.....	.28	.16	.30	.31
Salvage and refuse handling.....	.10	.24	.40	.42
Wet-rack handling.....	.02	.02	.17	.20
Takedown.....	<u>1/</u>	<u>1/</u>	.36	.25
Plan work, check records.....	.04	.03	.08	.32
Total time per master container.....	5.62	4.05	5.96	4.59
Personal and fatigue allowance--				
15 percent.....	.84	.61	.89	.69
Standard time per master container....	6.46	4.66	6.85	5.28
Percent of time saved.....		27.9		22.9

1/ Not obtained.

DISPLAY CASES

Both refrigerated and unrefrigerated display cases are used for produce. Refrigeration methods include forced-air refrigeration and icebed cooling. In the stores studied, mechanically refrigerated cases were most often used with packaged produce.

The Preparation of Display Counter Bases

Produce clerks in the stores studied spent considerable time in preparing or adjusting display counter bases.

One of the principal results of counter adjustment was to raise the produce, often out of the effective temperature-control area. In an effort to reduce the quantity of produce on display, for both mechanical and dry counters, the clerks used "dummies" (filler material placed under the produce). Aluminum foil and cardboard boxes were used in great quantities, as well as various other packaging supplies. In several instances, produce packaging supplies worth \$50 or more were found under the produce displays, and most of the supplies were no longer usable for packaging (fig. 7). Regardless of the display-case design, most produce managers spent considerable effort in changing the case base for different products.

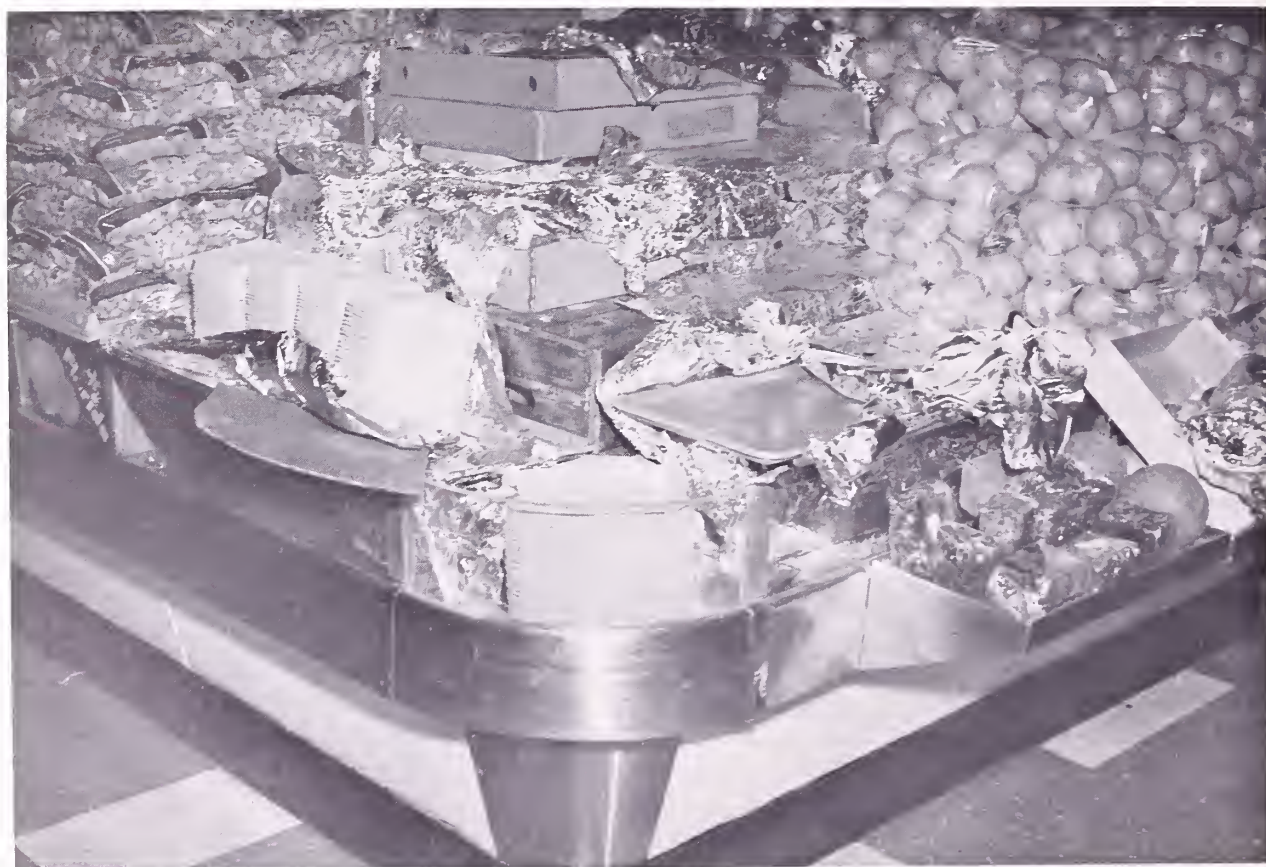

BN-16045

Figure 7.--Packaging supplies used as dummies in produce cases.

Where bulk produce was displayed in forced-air units, there was a tendency to block the flow of air. Reasons given by the store employees for this were to vary temperature for different products and to prevent the drying of some products. Plywood inserts were built, which caused dead-air space, shut off the circular flow of air, and raised the display.

The displays resulting from these efforts often reduced the selection area for the customer. Many customers would not select produce items from the front of a highly pyramided or stacked display for fear of causing produce to fall on the floor. These customers were limited in their selection to items on top of the display (fig. 8).

Glass fronts and deep-set recesses in the front of the case also caused considerable produce to be on display but not available to the customer. Merchandise in these pockets tended to be overlooked during rotation, and much merchandise spoiled.

A display counter was designed that provided a maximum selection area for the customer with a minimum of produce on display (fig. 9). Windows or glass fronts were removed, and counters were sloped to make the most merchandise possible available to the customer's view, with the least chance of produce rolling off on the floor.



Figure 8.--Cross section drawing of typical produce display counter bases showing the area of primary selection available to the customer.

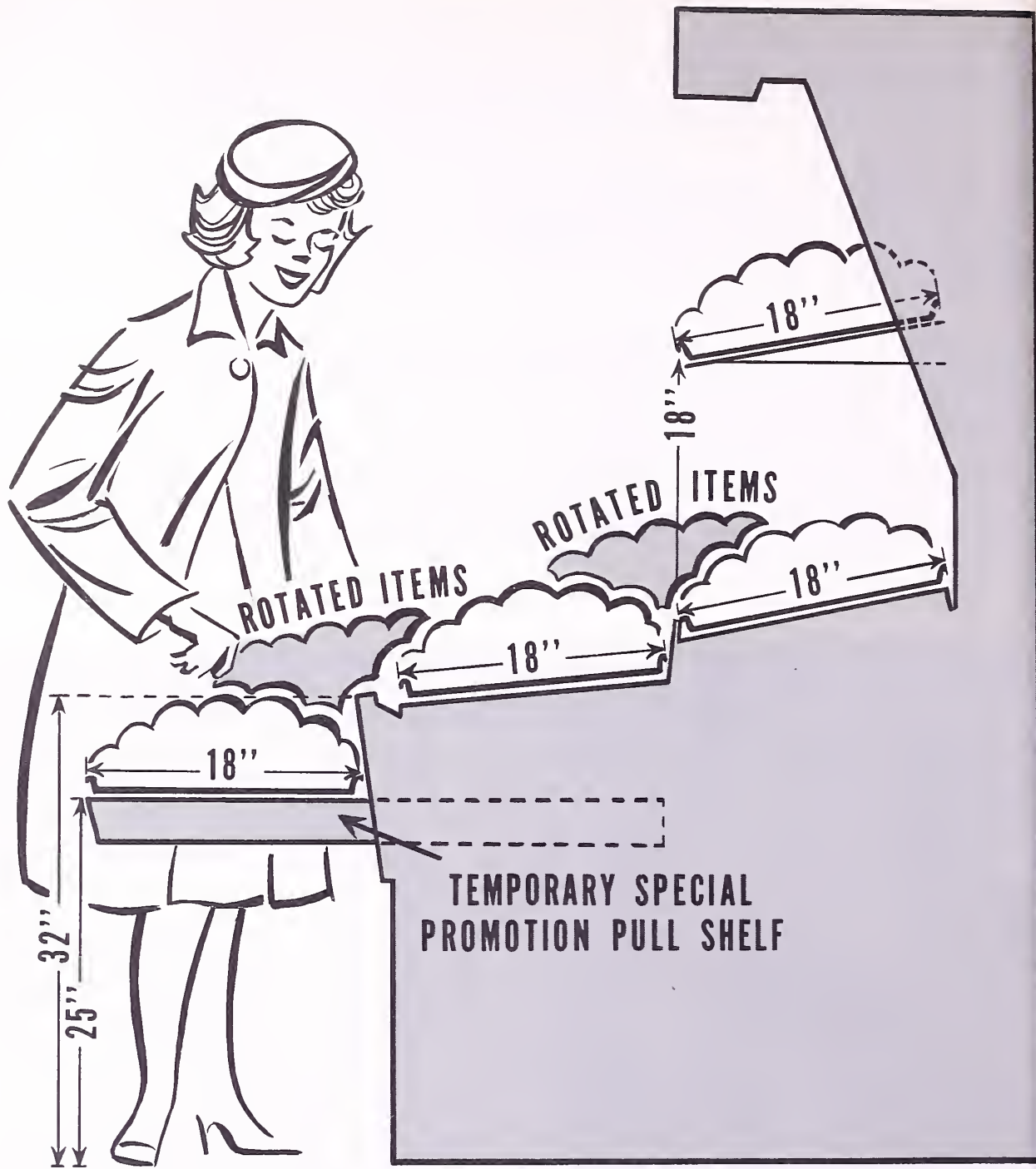
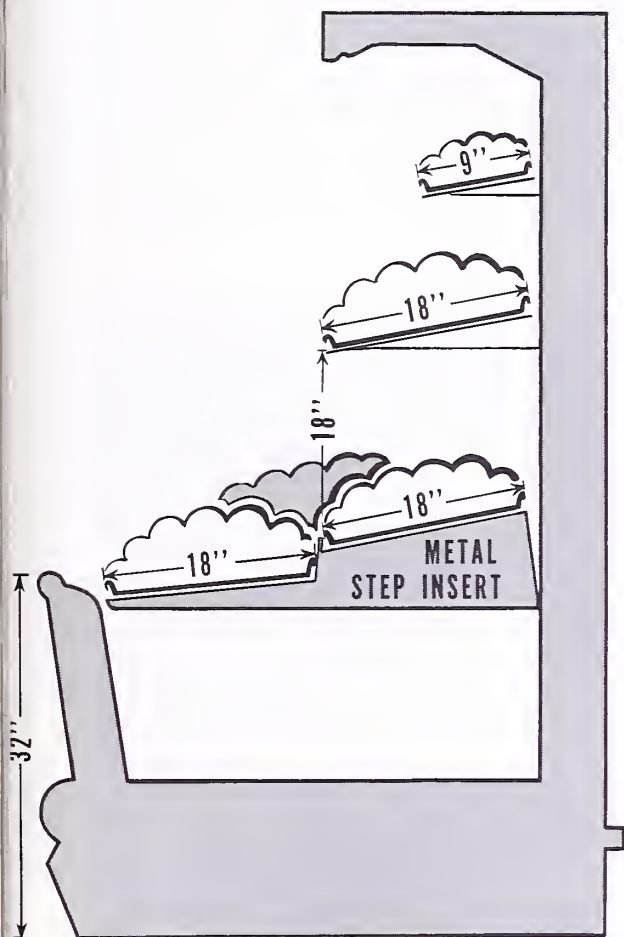

Figure 9.--Cross section of a step counter dry rack display showing position of second deck shelf and promotional extension stand.

Mass effects were achieved by adding shelf extenders to the front of the display. Extra shelves can be added above the displays for sales of slower-moving items. In instances where mirror backs are used, some operators have experimented with cutting down the space early in the week by hinging the mirror to swing forward and show only one tray of merchandise.

For mechanically refrigerated cases, inserts were placed in the case to provide the base (fig. 10). On icebed cases, the step was metal-lined so that ice could be dumped directly on it. With this system, most trim items can be given a complete display with one layer of merchandise.

The counter base was designed to hold trays as shelf liners, to make rotation easier and to allow a freer shifting of display location.



A. Cross section of a multideck refrigerated case with step inserts.

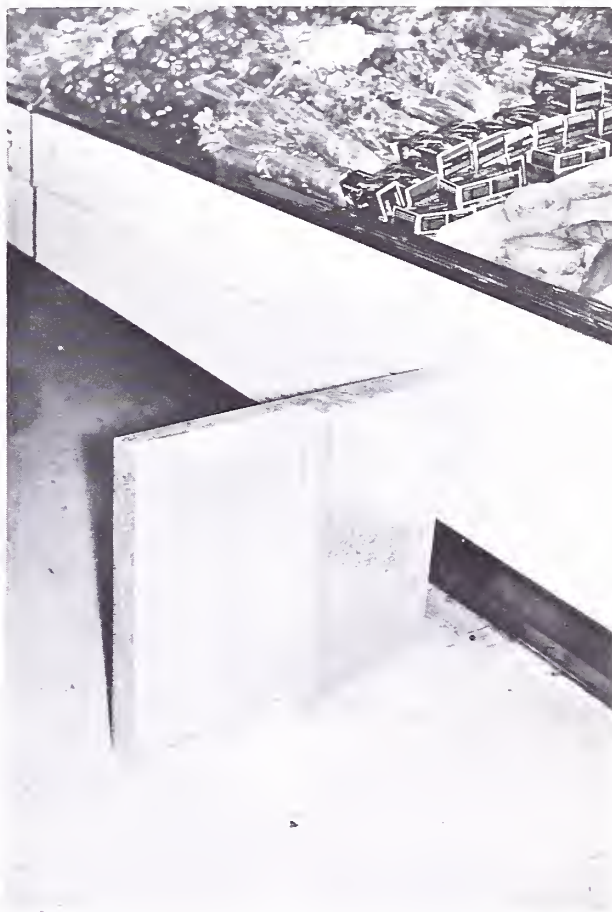

B. Inserts used in refrigerated cases to gain step counter effect.

Figure 10.--Cross section of a multideck refrigerated produce display case showing inserts added to the counter base to provide for tray handling.

Individual products were displayed in "blocks" rather than "ribbons." While each product was given about the same total surface, the mass of produce was closer together (fig. 11). For slower-moving items, a checkerboard system was used with one item in front of another. The advantage of this type of display was the ability to service the case with a minimum of labor. Clerks were able to have adequate displays with a minimum of merchandise and yet be able to expand the display quickly.

Multideck Displays

Most multideck produce display cases with either mechanical refrigeration or dry-storage racks are designed for hand placement of individual pieces of produce. These cases are very effective in the use of space, especially for slow-moving produce items or for small-volume stores. The problem for a large-volume produce department is to adapt these cases, by use of a stepped shelf base liner, so that trays can be used for display, (7) (fig. 10). Metal inserts designed to hold trays may be placed on top of the case's adjustable display base; these should have holes to permit passage of air (fig. 10B). In some instances of cases less than 36 inches from front to back, the trays may be inserted with the length of the tray front to back in the display. With this system no shelf base liner is needed. The second shelf may present no real problem, as it can be converted for single-tray use. Shelves above this level can then be utilized for a special container or used with hand displays of small items.

Rear-Service Display Cases

Rear-service produce display cases have not met with as much success as rear-service meat cases. This may be due in part to habit, since meat departments usually are serviced from the rear even when meat is sold in service form. The produce clerk, however, has traditionally been stationed in front of his displays. This, however, is not the only factor. Produce is usually handled in larger bulk than meat, with more pieces and more bulk for each type of item displayed. Produce also tends to have a higher slope toward the customer. Clerks say that they cannot see properly to arrange the display for satisfactory customer appearance. Time studies made of rear-service display indicate it takes longer to display from the rear than the front (table 11). Display methods from the rear tend to become a hand-to-hand pass of each item and few bulk handling techniques can be used.

Table 11.--Comparative time per piece required to place selected produce items on front- and rear-service displays using the hand-to-hand pass method

Item	Display from front	Display from rear
	<u>Minutes</u>	<u>Minutes</u>
Bag carrots.....	.024	.027
Eggplant.....	.024	.030
Bag lettuce.....	.022	.030
Corn.....	.021	.027
Celery.....	.027	.028
Cabbage.....	.027	.027
Average.....	.024	.028
Savings.....	14%	

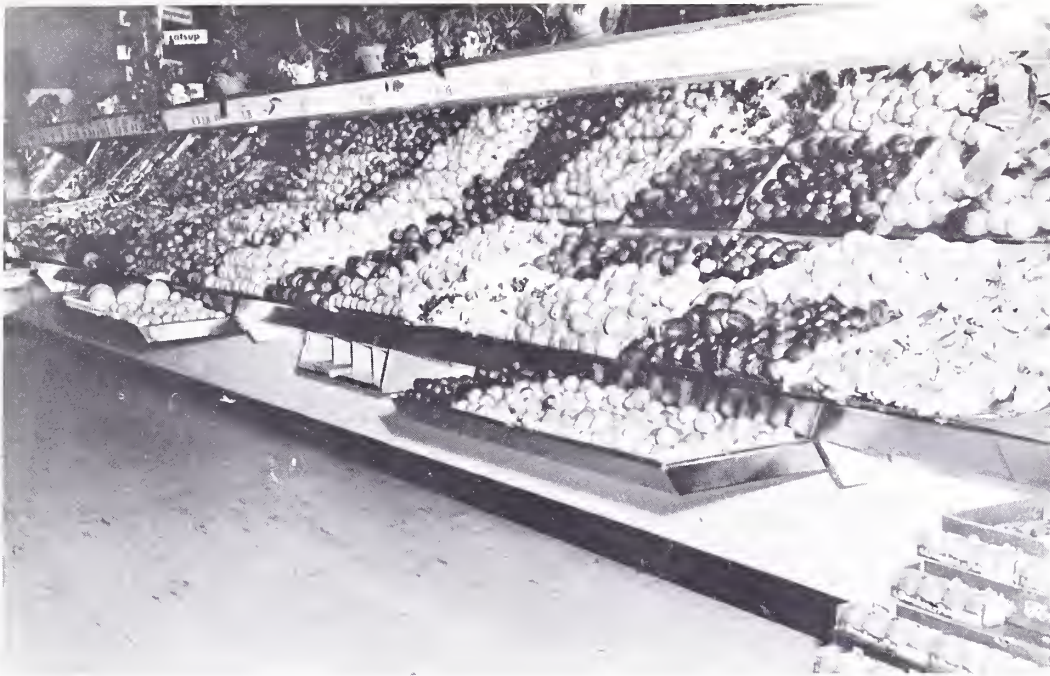

BN-16028

A. Dry rack.



BN-16046

B. Refrigerated rack.

Figure 11.--Produce displays using the "checkerboard" method of product placement.

The confusion of containers, carts, and other produce equipment traditionally kept in produce backrooms and behind the cases also tends to complicate rear service. If the 3-foot aisle, considered minimum for rear service, were added onto the selling aisle, the net effect would be more space and less confusion for both customers and clerks (3).

UNIT HANDLING

Unit handling involves moving a box or container of produce instead of individual pieces. For example, produce clerks may move and display the item in the original shipping container. Placing produce on display requires considerable individual handling, and it is here that unit handling provides an opportunity for the greatest possible improvement.

Tray Display

The system, developed by researchers, of arranging produce on trays in backrooms and inserting an entire tray of merchandise into the counter is called tray display. The trays are either wire baskets for use with wet merchandise or pans for use with dry merchandise. The most common pan or basket size is 18 x 27 inches, which holds approximately one shipping container of new merchandise. The concept of displaying merchandise in trays is not new, and has previously been used in service meat counters and by many fruit and vegetable stores. Adapting the method to modern self-service supermarkets, however, requires considerable engineering. In this system, produce is removed from its original shipping container at backroom production tables or at the trimming station and placed on the display tray ready for the counter. The trays are then placed on mobile racks for transporting either to the cooler or to the selling floor.

When some bulk items such as apples, string beans, or peas are displayed loose without pyramiding, the pans used would not hold a normal-size box of produce. In such cases, a tray "collar" is used to build up the sides of the tray and hold the merchandise until ready for display (fig. 12). These collars provide sides for the tray but have no bottom. When the tray is placed on the display counter, the collar can be pulled up, allowing the merchandise to spread and give the display a fuller appearance.

In some cases these collars were left on the pans in order to hold small loose items, such as chestnuts or white onions, on the display.

Some slow-moving items may be displayed with two or three different items on a tray. This is usually done when the product does not require rotation more than once a day.

Restocking the Display Case

Restocking the display with trays involves removing an empty or partially empty tray of produce from the counter, and replacing it with a full tray (fig. 12B). The previously displayed produce is then placed on top of the new display, and inspecting and checking for quality are done in the process.



BN-16029

A. Inserting trays into the display.

Figure 12.--Displaying produce by the tray display method.

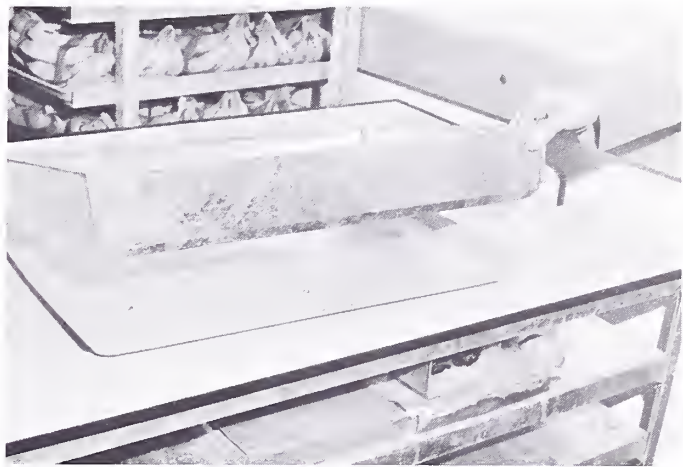

BN-16030

B. Tray collar used on some bulk displays.

The rotation procedure for items, such as lettuce, that are displayed on two trays was to move old merchandise from the forward tray to the rear tray by hand. The front tray was removed and the rear tray pulled forward. A tray of new merchandise was then inserted in the rear slot and the display leveled. When the operator desired to build the display higher, both trays could be removed and replaced, and previously displayed merchandise placed on top.

Display and rotation time vary according to the commodity and according to how much rotation is done. Few stores rotated each commodity every time the display was filled.

The time required to rotate and display various commodities with comparable quantities of produce on display and of newly added produce is shown for hand methods and for tray use (table 12). Savings for the tray method ranged from 1 to nearly $3\frac{1}{2}$ minutes per crate. In this table an equal amount of rotation was done on each display, whether by hand or with trays. For commodities not needing complete rotation every time the displays were filled, merchandise was added to the top of the displays, usually by dumping. Under normal operating conditions, it was noted that considerably more attention was given to rotation when tray display was used. While this tended to decrease the time saved, it generally improved the quality of the merchandise on display.

Table 12.--Comparison of handling five commodities with and without the tray display system, in minutes per crate of merchandise sold

	Iceberg lettuce : : with wire tie :		Bulk string : : beans :		Bagged : : carrots :		Bulk apples, : : field crate :		Fancy apples, : : store-packaged 6's :	
	Conven- : tional :	Min. : :	Conven- : tional :	Min. : :	Conven- : tional :	Min. : :	Conven- : tional :	Min. : :	Conven- : tional :	Min. : :
	Tray	Tray	Tray	Tray	Tray	Tray	Tray	Tray	Tray	Tray
Display.....	.79	.21	1.22	.45	1.72	.28	2.70	.45	1.02	.24
Rotate, rearrange, and redisplay.....	1.08	.46	2.78	1.02	.73	.54	1.84	.83	1.60	.63
Handling at display:	1.95	.80	1.53	.75	.78	.47	1.11	.49	1.48	.73
Travel.....	.44	.28	.46	.28	.46	.28	.46	.28	.46	.28
Backroom produc- tion.....	4.63	1/4.63	-	1.56	-	1.49	-	1.67	2.24	1/2.24
Handling container: in backroom.....	1.91	1.90	1.35	1.12	1.30	1.07	1.07	.84	1.50	1.27
Total.....	10.80	8.28	7.34	5.18	4.99	4.13	7.18	4.56	8.30	5.39
15% fatigue and personal allow- ance.....	1.62	1.24	1.10	.78	.75	.62	1.08	.68	1.25	.81
Standard time.....	12.42	9.52	8.44	5.96	5.74	4.75	8.26	5.24	9.55	6.20
Savings.....		2.90		2.48		.99		3.02		3.35

1/ No difference noted in tray display.

Counter Setup

One of the most efficient uses of tray display is in setting up display counters at the beginning of the day.

When using the tray system, the produce manager first prepares a list of commodities needed for the displays, ordering them by baskets or pans. These are prepared in the backroom and loaded on carriers; some merchandise can be prepared the night before. (Retrimmed produce is placed on top of the new merchandise.) The clerk then removes the carriers to the selling floor and places the trays on display according to a prearranged plan. A large produce department can be completely set up in 10 minutes if the produce has been properly prepared in the backroom. The tray method also allows flexibility in placing merchandise. For example, extra trays of staple merchandise can be used to fill the case until out-of-stock items arrive. The time saved in shifting displays is one of the advantages for the tray method of handling produce (table 12).

Takedown

Trays are effective also for taking merchandise off the counter for storage at night in refrigerated coolers. The clerk on duty consolidates produce in the trays about 30 minutes before closing time. When two or more trays of an item are on display, merchandise is moved to one tray and empty trays are removed. Items are removed from between trays so that no overhang exists. When the store closes, the clerk returns with empty tray carriers and removes the trays from the counter. Merchandise that is to be trimmed or reworked is kept separate from items that can be returned to the display. These carriers are then moved into the produce cooler and the cases and floor are cleaned.

Preparation of Trays

A work station for preparation of merchandise for tray display should have all necessary tools and materials located conveniently for the operator. Backroom production work for tray display falls into three classes: Trimming, packaging, and filling trays. The trimming stations used were the USDA-designed right-angle units with sinks (2). A holding rack was added for trays, usually over the sink, and as the operator completed the work on each item (including pricing), he placed it in the tray ready for display (fig. 13). Some trimmers used a holding basket and separated the operations of trimming and bagging. The use of tray display procedures added no time to the trimming operation.

For produce packaged in the store, the USDA-designed right-angle packaging table was used, and packages were placed in the tray as completed (6). Packaging work is done in exactly the same way as that without tray display, because in this case, the tray substitutes for a tote box. The tray carriers proved superior to other carriers for packaged produce, because of the open-end loading.

The USDA-designed table described for prepackaging is adequate for preparing merchandise for bulk tray display, but not all of the packaging supplies that are provided are necessary. The work station should be near the salvage and trash storage area. The operator places an empty tray directly in front in the space normally used for packaging and thus moves merchandise the shortest possible distance from the box or container to the tray.



BN-16047

Figure 13.--Workplace for trimming produce and preparing it for tray display.

He needs a low-deck cart to move merchandise to the work station, storage facilities for pans, collars, and other equipment, and parking space for a merchandise carrier. The table should provide a holding shelf for a shipping container of produce. This shelf is used to hold the container while it is being opened and to work from when hand-placing items on the tray (fig. 14).

Preparing bulk trays of merchandise in the backroom at an organized workplace is faster than transferring the items directly into the case. When volume of business justifies, different personnel should be assigned to the backroom tray preparation and to the counter display functions. This allows for specialization of skills, and encourages some advance planning of display needs.

Advantages of Tray Display

The tray display system has a number of advantages for retail operators. These are:

1. Reduced handling of the product.--With the tray system, less handling of individual items is done. This helps to reduce damage and shrinkage and saves labor.



BN-16031

Figure 14.--Workplace for preparation of bulk produce for tray display.

2. Better rotation.--It is difficult to rotate produce in conventional displays. With the tray system, produce was rotated nearly every time the display was filled, with the result that a much better quality of produce was on display.
3. Less congestion on the selling floor.--Clerks are able to fill displays more rapidly and thus spend less time on the selling floor, blocking the aisles.
4. Neater sales area.--Boxes and other packing materials stay in the back-room. Only carriers with trays are moved to the selling floor.
5. Flexibility of display location.--Changing the location or size of the display was one of the time-consuming jobs in conventional produce departments. With tray display, pans are readily shifted.
6. Better display planning.--Clerks can plan on a definite number of trays to fill the display and arrange them quickly and easily.
7. Fixed workplaces, saving labor.--When display preparation is done on the floor, clerks work at inefficient heights and have difficulty in using good work methods. Better production, with less effort, can be obtained by using a fixed workplace.

8. Equalization of workload by advance preparation of displays.--In conventional produce departments, most of the display work cannot be done until the counters need more merchandise. With tray display, most of the work can be done in the backroom when convenient.

9. Maintenance of full displays by clerks.--Tray display enables clerks to replenish a display quickly when necessary. Thus, counters can be kept full, even during heavy selling periods, when there has been advance preparation.

Good managerial ability is important with the tray display system, just as it is with any other system. To use tray display effectively, the manager must schedule his production work well ahead of need. Also, for the tray display system to work effectively, adequate equipment of the right kind must be provided. While this added cost is nominal in a new store, where tray display equipment can be purchased rather than other items and equipment, in older stores the equipment and modifications may cost several thousand dollars.

Rolling or Mobile Displays

Rolling displays are mobile display units which can be moved to permit relocation or to facilitate stocking. These are usually built in the form of segments of display cases or shelving, and they provide a small segment of a display which can be removed and taken to the backroom for stocking.

Portable Display Bin

One of the most common types of mobile displays is the rolling potato bin (fig. 15). Most of the units tested were designed to be loaded in the backroom for storage, or directly from the delivery truck. For the system to work effectively, several of these bins must be kept in reserve in the backroom. When produce stock in a bin runs low, it is replaced by a full bin from the backroom. The produce left in the old bin is placed on top of the new merchandise to complete the operation.

Several mechanical problems were noted in the bins studied. Many of the bins were too large for the amount of produce in the displays. As a result, more than one commodity was often displayed in each bin, limiting the use of the bin for rotation. They were too heavy, when full, to be readily moved by the store employees. Many of the casters were too small for the load or were of a soft rubber material which increased the difficulty of moving them with a full load. A rolling bin with slower-moving bagged items needs adequate "dummies," or space fillers, so that a full appearance can be given without displaying too much merchandise. A shelf at the top of the bin can be used effectively to hold pans or baskets of small items associated with the potato and onion display. Another type of bin without wheels can be built to place over semilive skids or for use with pallet jacks.

To make the most effective use of rolling bins, several new designs were tested. These bins incorporated the following features:

1. A size small enough so that they may be used exclusively for one item.
2. Nylon or hard-rubber casters capable of moving a full load.
3. Swivel casters on front or back only.



BN-16036

A. Full-castered bin.



BN-16037

B. Semilive skid bin.

Figure 15.--Mobile display bins for handling and displaying bulk produce items.

4. Adjustable dummies in the bin to allow flexibility, preferably attached to the bin so they cannot be removed (this permits maximum opportunity of selection with a minimum of product on display).
5. A shelf at the top of the bin which can be used for small items when displays are lower than the top of the bin.
6. The leading edges of the bins should be cut back enough to allow customers a full view of the produce.

Rolling bins are most commonly used with bagged potatoes and onions, but they also work well for high-volume bagged fruits, such as oranges and apples, for watermelons, and for some nonfood items, such as charcoal briquettes.

The amount of labor saved by bins is highest when produce is received from the truck and placed directly into the bins. Watermelons and 10-pound bags of potatoes were frequently handled in this manner. The chief advantage of using bins was the capability of preparing displays in advance in the backroom, and thereby reducing congestion on the sales floor.

Display bins were most effective when used in conjunction with some of the regular display shelving for the slowest moving bagged items, and when a surplus of bins in the backroom equal to one-half the number actually on display was provided. Usually, not all the display bins were placed on display during the first part of the week. When the floor area reserved for them was tiled like the rest of the store floor, this did not appear to be a vacant space as would a similar area in a fixed display which has an unfinished floor.

Data from time studies for handling 5- and 10-pound bagged potatoes by several methods are shown in table 13. Bins on semilive skids required extra handling, due to the use of a jack, and took somewhat longer to operate than bins with wheels. It required less time to handle 5- and 10-pound bags of potatoes in bins than with conventional methods.

Table 13.--Time per bag to handle and display 5- and 10-pound bags of potatoes with or without bins 1/

Activity	: Conventional		: Wheeled bins		: Semilive bins	
	: 4- & :	: 10-lb. :	: 4- & :	: 10-lb. :	: 4- & :	: 10-lb. :
	: 5-lb. :	: bag :	: 5-lb. :	: bag :	: 5-lb. :	: bag :
	: <u>Min.</u>	: <u>Min.</u>	: <u>Min.</u>	: <u>Min.</u>	: <u>Min.</u>	: <u>Min.</u>
Receiving.....	.116	.204	: .121	.214	: .123	.216
Packaging <u>1/</u>522	.720	: .522	.720	: .522	.720
Load for display.....	.016	.076	: -	-	: -	-
Travel.....	.033	.068	: .010	.018	: .022	.033
Display.....	.061	.109	: .003	.005	: .005	.010
Handling at display.....	.026	.050	: .015	.031	: .015	.031
Rotate and rearrange.....	.017	.031	: .015	.023	: .015	.023
Handle broken bags.....	.010	.014	: .002	.007	: .002	.007
Totals:	:	:	:	:	:	:
Received packaged.....	.279	.552	: .166	.298	: .182	.320
Packaged in store.....	.801	1.272	: .688	1.018	: .704	1.040

1/ Excludes a savings in time for receiving in 50- or 100-pound bags.

Watermelon Racks

Another version of the display bin was developed by adapting semilive skids as watermelon racks. A rack of this type consisted of a folding frame which, when placed over the skid, formed a bin for storage of melons (fig. 16). While these bins were of rough lumber, they were often used on the selling floor by draping the sides with grass matting or large advertising signs. Labor saved in handling watermelons, compared to that in the usual practice of using shopping carts, was more than 5 hours per 1,000 melons (5). When not in use, the racks were folded and placed in storage. These racks were used also for temporary storage of trash and salvage. Some of the advantages of rolling display bins are:

1. Complete rotation is easy.
2. Some of the display work can be done in advance.
3. Flexibility--space can be readily adjusted by adding or removing bins.
4. Less handling.
5. Fewer damaged packages than in conventional displays.

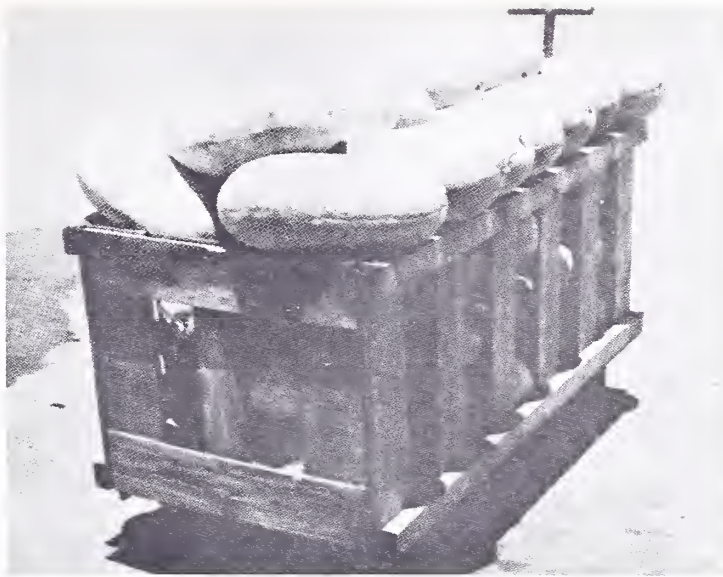

BN-16032

Figure 16.--Racks on semilive skids for handling watermelons in retail food stores.

For proper use of rolling display bins, the display size must be keyed to the size of the bin. Bins are not as efficient when several types of items are displayed in each bin. The pricing policy of the company also needs to be considered. Last-minute price changes caused difficulties in some instances, where merchandise had been priced ahead and placed in bins in advance of their need in the displays.

Mobile Multishelf Displays

Another type of rolling display is under development, which uses pans or baskets in tiers on a highboy carrier (fig. 17). These devices have several shelves available to the customer, and are used for a variety of fruits and vegetables, displayed in a manner similar to that in the tray display method, with each pan removable for replenishment. At the time this report was written, the units did not have refrigeration, but experimentation with air-curtain refrigeration was underway. This would allow a row of these rolling displays to be parked under the refrigeration unit, giving complete flexibility in display placement, with either front or back available for service, and could eliminate one additional handling of the product:

Another important system of handling mobile displays is still under study. Greater efficiency in the use of mobile displays will ultimately be achieved when these displays are prepared in the warehouse or processing plant as the product is taken from the processing line. This operation will require better means of shipping the bins to the store, to prevent shifting of the load and damage to the bins in transit. Present shipping practices tend to damage containers so that they are not as attractive when on display. Another problem is to prevent too much loss of space in the trailer so that delivery costs do not increase excessively. Once these problems are solved, this system holds great promise as a means of reducing handling costs.

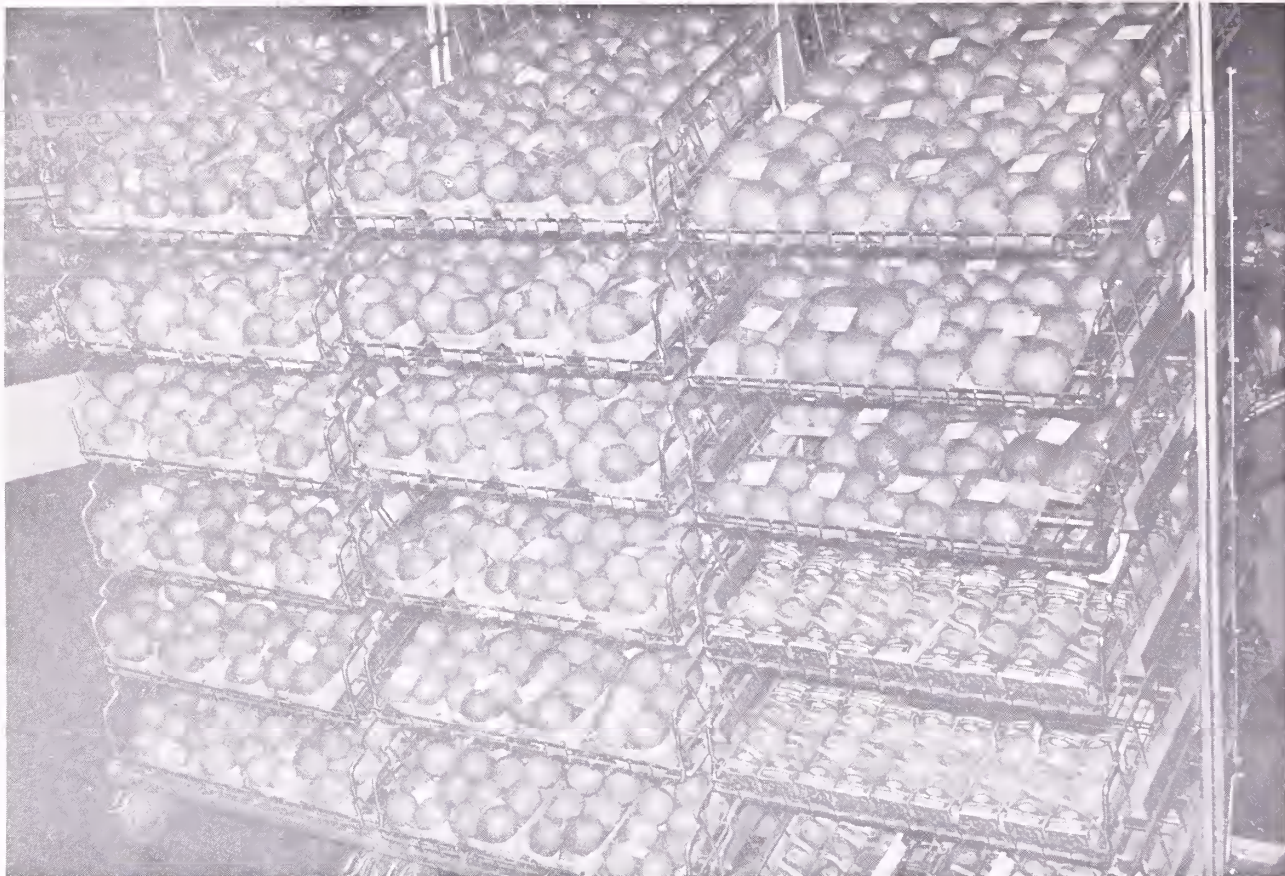

BN-16033

Figure 17.--A new type of rolling retail display shelf used for produce and other items.

Effect of Use of Tray Display and Rolling Display Bins

The application of the tray display system to existing stores usually results in substantial labor savings. Other improvements in handling and display may also result in substantial labor savings.

To evaluate the tray display system, the researchers first made as many improvements in the operation of three existing stores as they could without use of trays or bins. The resulting operations were analyzed in detail. These stores were then converted to use of trays and bins and the studies were repeated. The data were adjusted so that each comparison represents an average of the produce carried by each store, but the work methods studied were those used by employees after training. Not all of the produce was displayed by the tray method.

The tray system for bulk produce resulted in considerable extra effort in rotation. One result was a much better quality of product on the shelves (table 14).

Table 14.--Comparison of handling times for produce in stores using conventional display methods and tray display

	Store A			Store B			Store C		
	Improved : methods	Bulk : tray : display	Prepack : tray : display	Improved : bulk	Bulk : tray : display	Prepack : tray : display	Improved : prepack	Bulk : tray : display	Prepack : tray : display
	Min.	Min.	Min.	Min.	Min.	Min.	Min.	Min.	Min.
Time per master container to									
Select and load merchandise for display.....	.20	.21	.19	.25	.28	.28	.31	.28	.23
Obtain materials and equipment.....	.19	.21	.40	.20	.28	.58	.65	.58	.48
Other backroom handling.....	.09	.17	.15	.10	.22	.21	.24	.21	.18
All display travel.....	.46	.34	.32	.50	.48	.50	.56	.50	.43
Display (including price as display).....	1.05	.46	.41	1.27	.41	.55	1.08	.55	1.25
Rotate, rearrange, police.....	.59	.81	.55	.44	.74	.44	.86	.44	.66
Open containers.....	.12	.10	.10	.26	.24	.24	.24	.24	.22
Handle discount merchandise.....	.16	.06	.17	.22	.08	.22	.22	.22	.18
Other display handling.....	.31	.17	.17	.33	.22	.25	.28	.25	.21
Salvage and refuse handling.....	.42	.28	.21	.57	.25	.25	.25	.25	.42
Net rack handling.....	.20	.15	.15	-	-	-	-	-	.02
Takedown.....	.25	.17	.15	.55	.25	.02	.02	.02	.41
Redisplay.....	.23	.40	.15	.35	.22	.26	.28	.26	.23
Plan work, check records	.32	.32	.29	.11	.11	.11	.11	.11	.11
Backroom production and pricing.....	1.03	1.36	4.10	2.82	3.77	9.21	8.89	9.21	8.93
Total time per case.....	5.62	5.21	7.51	7.95	7.55	13.12	13.99	13.12	13.96
Personal and fatigue allowance.....	.84	.78	1.13	1.19	1.13	1.97	2.10	1.97	2.09
Standard time per case..	6.46	5.99	8.64	9.14	8.68	15.09	16.09	15.09	16.05
Savings.....		.47			.46	1.00		1.00	1.16

In prepackaging operations, the amount of produce packaged varied between stores. Store A, for instance, packaged only that produce which had to be packaged for self-service. Some uniform-size fruits were sold on a piece basis, and little packaging was done for the wet-rack items. Store B did considerable packaging, even when operating with bulk sales, especially of potatoes and onions. Store C packaged all produce.

No comparison can be made between prepack and bulk departments on the basis of table 13, because customer service time was not included for bulk operations.

In general, savings for bulk departments through use of tray display and mobile display bins amounted to slightly less than $\frac{1}{2}$ minute for every case handled. The saving for prepack stores was about 1 minute per case (table 14). These savings ranged from 8 to 19 hours per 1,000 cases handled.

LITERATURE CITED

- (1) Agricultural Marketing Service and Federal Extension Service.
1960. Managing and Scheduling of a Retail Produce Department.
Mktg. Bul. 11, 12 pp., illus.
- (2) Anderson, D. L., Shaffer, P. S., and Hapner, Francis.
1957. Improved Methods of Trimming Produce in Retail Food Stores.
U. S. Dept. Agr. Mktg. Res. Rpt. 192, 48 pp., illus.
- (3) Anderson, D. L., and Shaffer, P. S.
1961. Display Location and Customer Service in Retail Produce
Departments. U. S. Dept. Agr. Mktg. Res. Rpt. 501, 50 pp. illus.
- (4) Lewis, William E.
1959. Maintaining Produce Quality in Retail Stores, U. S. Dept. Agr.
Handb. 117, 50 pp., illus.
- (5) Shaffer, Paul S., and Anderson, Dale.
1956. Unloading and Receiving Produce in Retail Food Stores.
U. S. Dept. Agr. Mktg. Res. Rpt. 129, 14 pp., illus.
- (6) Shaffer, Paul, Anderson, Dale, Wischkaemper, Paul, and Karitas, James
1958. Packaging and Price-Marking Produce in Retail Food Stores.
U. S. Dept. Agr. Mktg. Res. Rpt. 278, 86 pp., illus.
- (7) Toothman, James S., and Anderson, Dale L.
1958. Equipment Specifications for Tray Display of Produce in Retail
Stores. U. S. Dept. Agr. Mktg. Res. Rpt. 279, 18 pp., illus.

APPENDIX

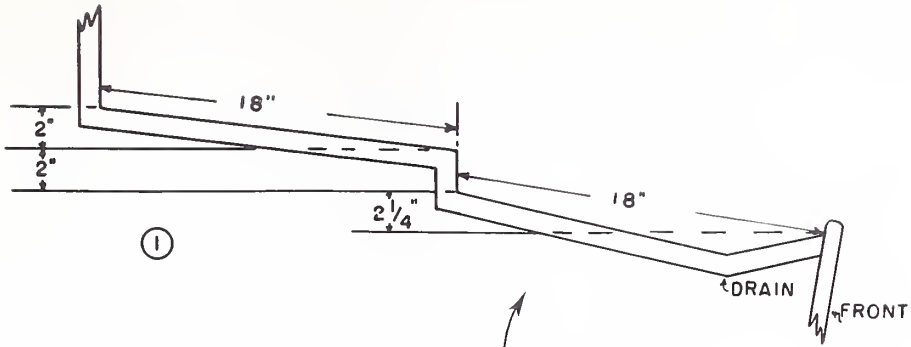

CROSS SECTION

ALTERNATE WET RACK COUNTER LINERS

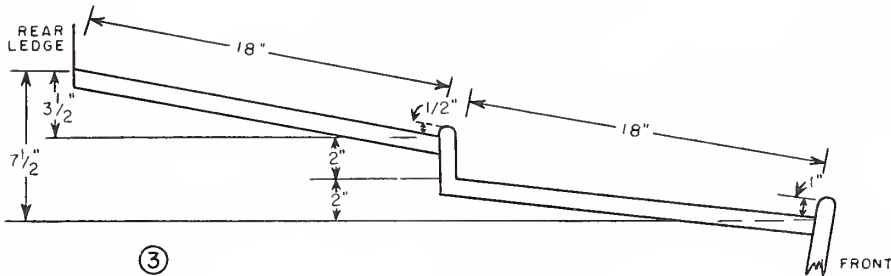
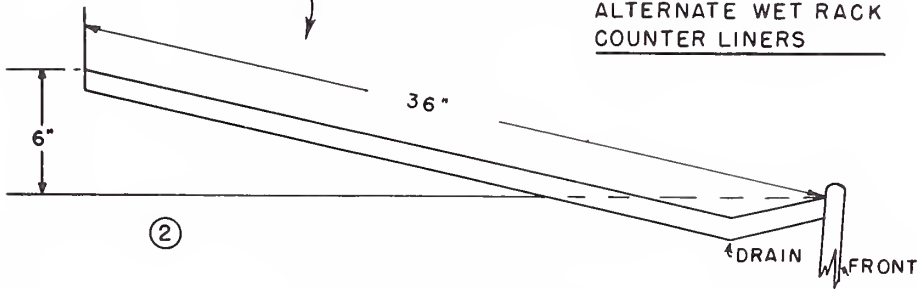

DRY RACK COUNTER LINER

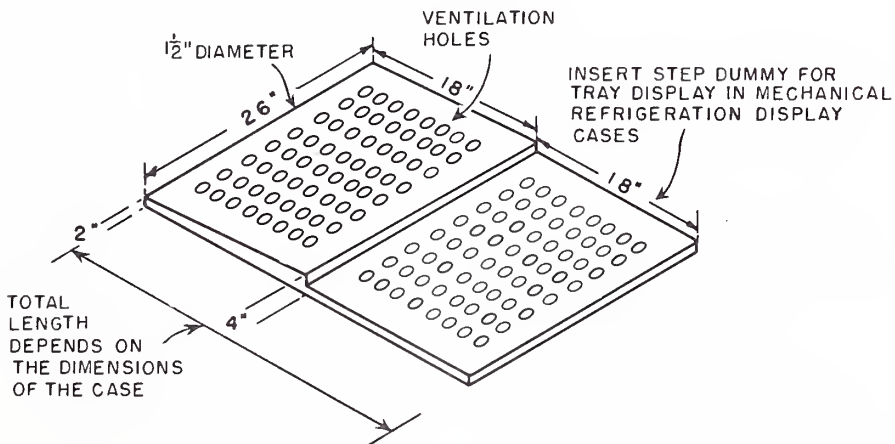
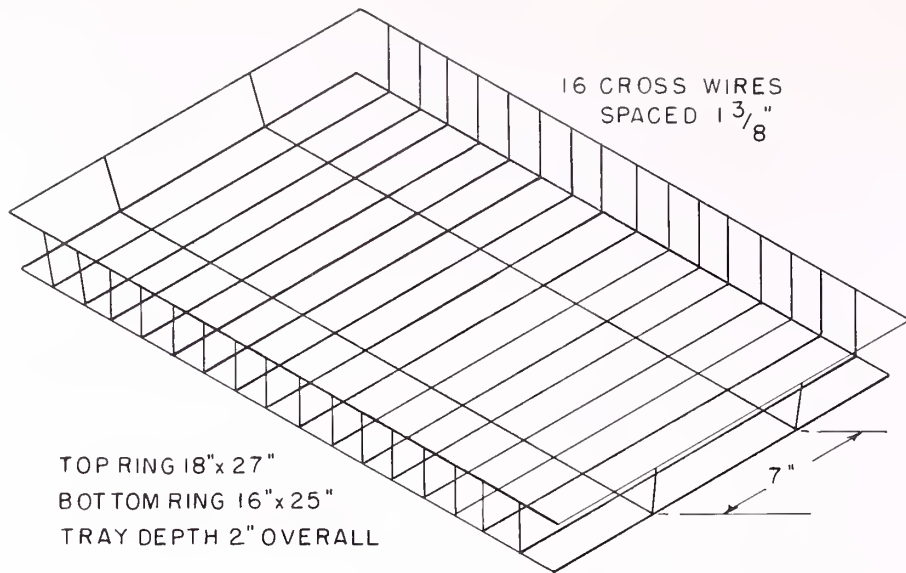
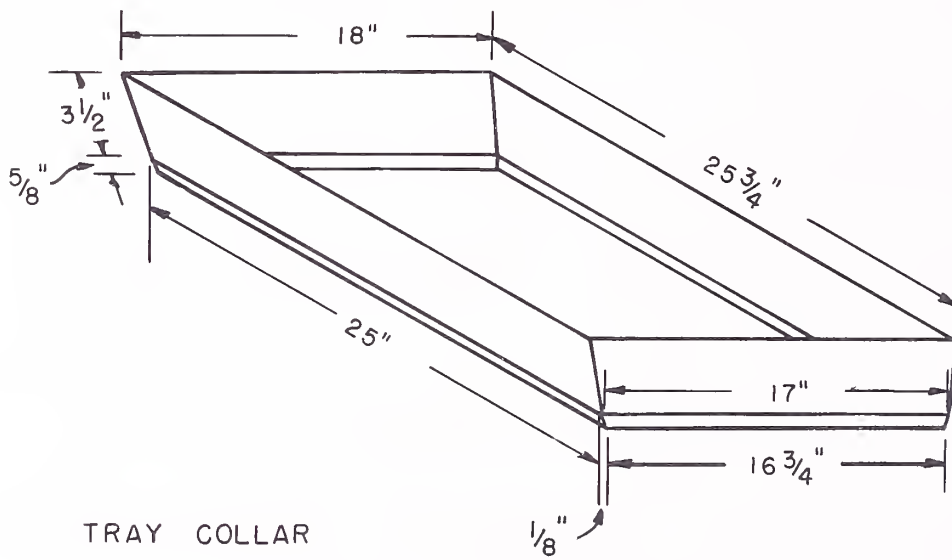

Figure 18.--Counter base for various display racks used with tray display.



WIRE TRAY FOR WET RACK PRODUCE

U.S. DEPARTMENT OF AGRICULTURE NEG 6328-58(7) AGRICULTURAL MARKETING SERVICE



U.S. DEPARTMENT OF AGRICULTURE

NEG. 6328-58(7) AMS

Figure 19.--Wire tray for wet rack produce and tray collar used on pan in tray display.

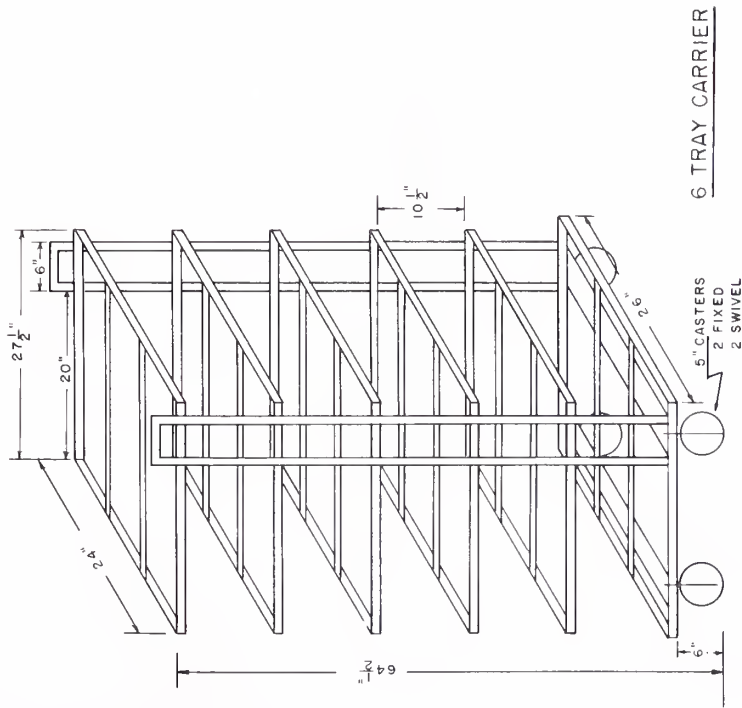

(NOTE: THIS DRAWING SHOWS ONLY CONFIGURATION AND DIMENSION)
 U.S. DEPARTMENT OF AGRICULTURE NEG. 6329-58 (7) AGRICULTURAL MARKETING SERVICE

Figure 20.--Single tier 6-tray carrier for produce.

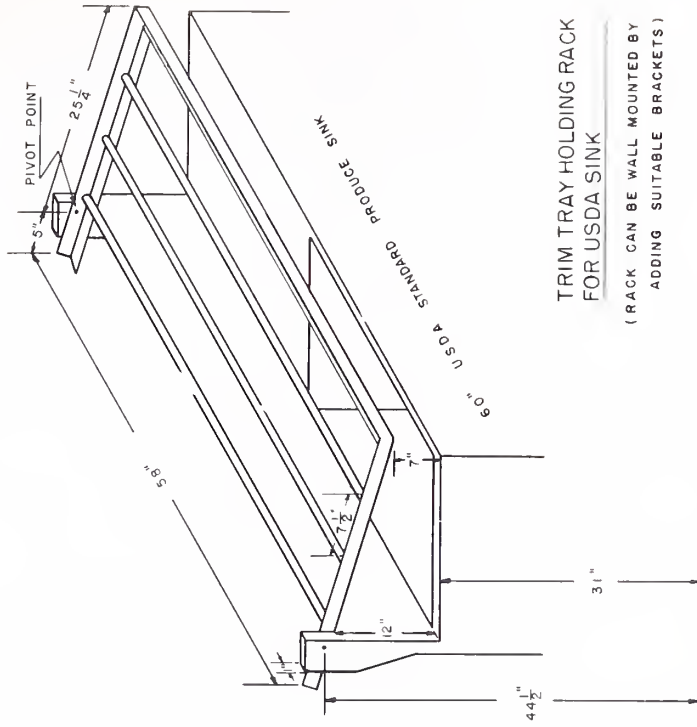

TRIM TRAY HOLDING RACK
 FOR USDA SINK

(RACK CAN BE WALL MOUNTED BY
 ADDING SUITABLE BRACKETS)

(NOTE: THIS DRAWING SHOWS ONLY CONFIGURATION AND DIMENSION)
 U.S. DEPARTMENT OF AGRICULTURE NEG. 6332-58 (7) AGRICULTURAL MARKETING SERVICE

Figure 21. Holding rack for sink used at trimming workplace for produce tray display of bulk produce.

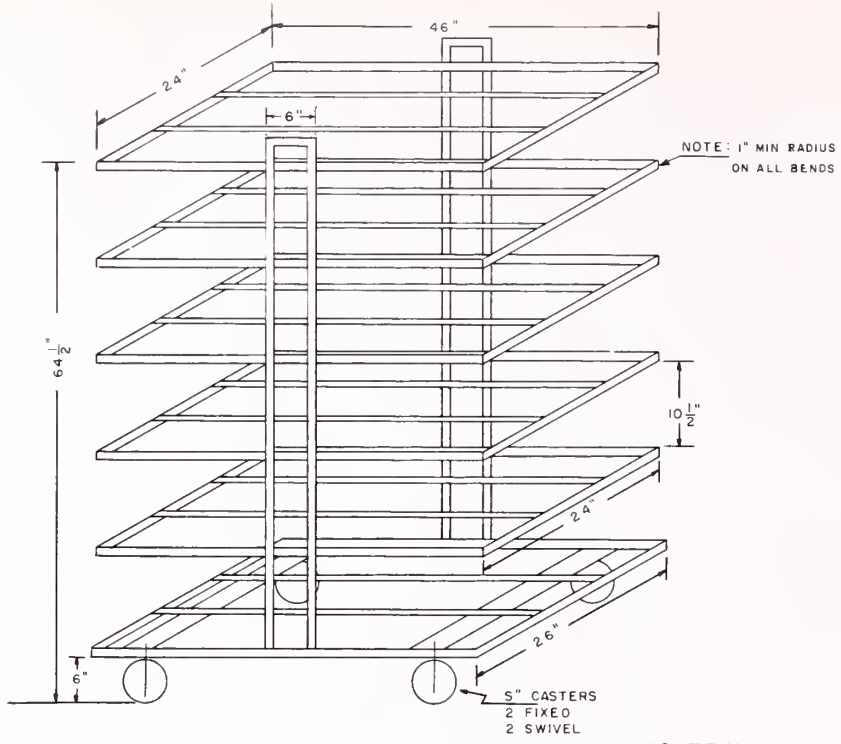

(NOTE: THIS DRAWING SHOWS ONLY CONFIGURATION AND DIMENSION)

12 TRAY CARRIER

U S DEPARTMENT OF AGRICULTURE

NEG 6330-58(7) AGRICULTURAL MARKETING SERVICE

Figure 22. Double tier 12-tray carrier for produce.

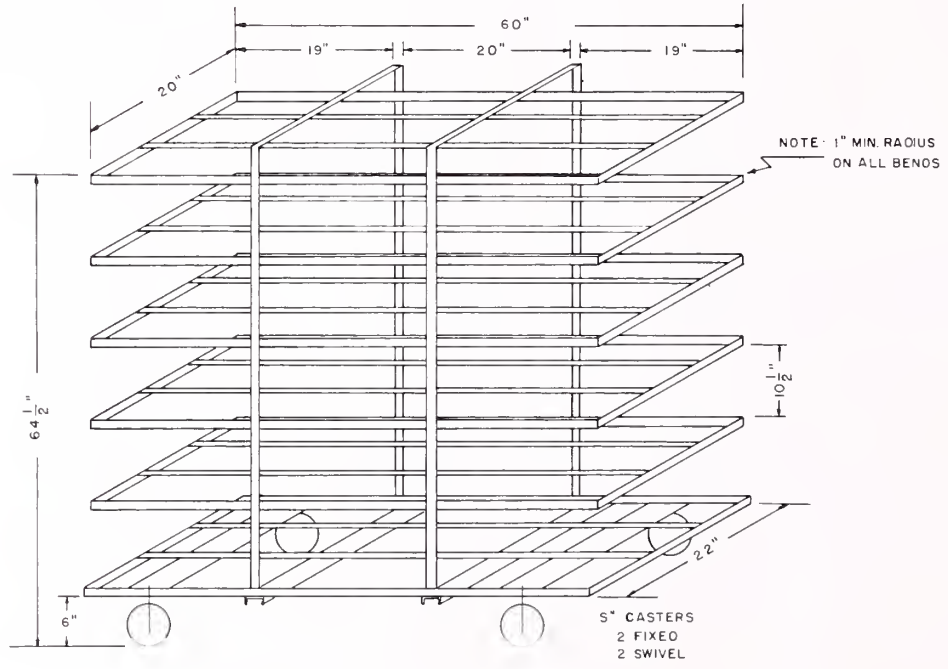

(NOTE: THIS DRAWING SHOWS ONLY CONFIGURATION AND DIMENSION)

18 TRAY CARRIER

U S DEPARTMENT OF AGRICULTURE

NEG 6331-58 (7) AGRICULTURAL MARKETING SERVICE

Figure 23.--Triple tier 18-tray carrier and mobile storage rack for produce.

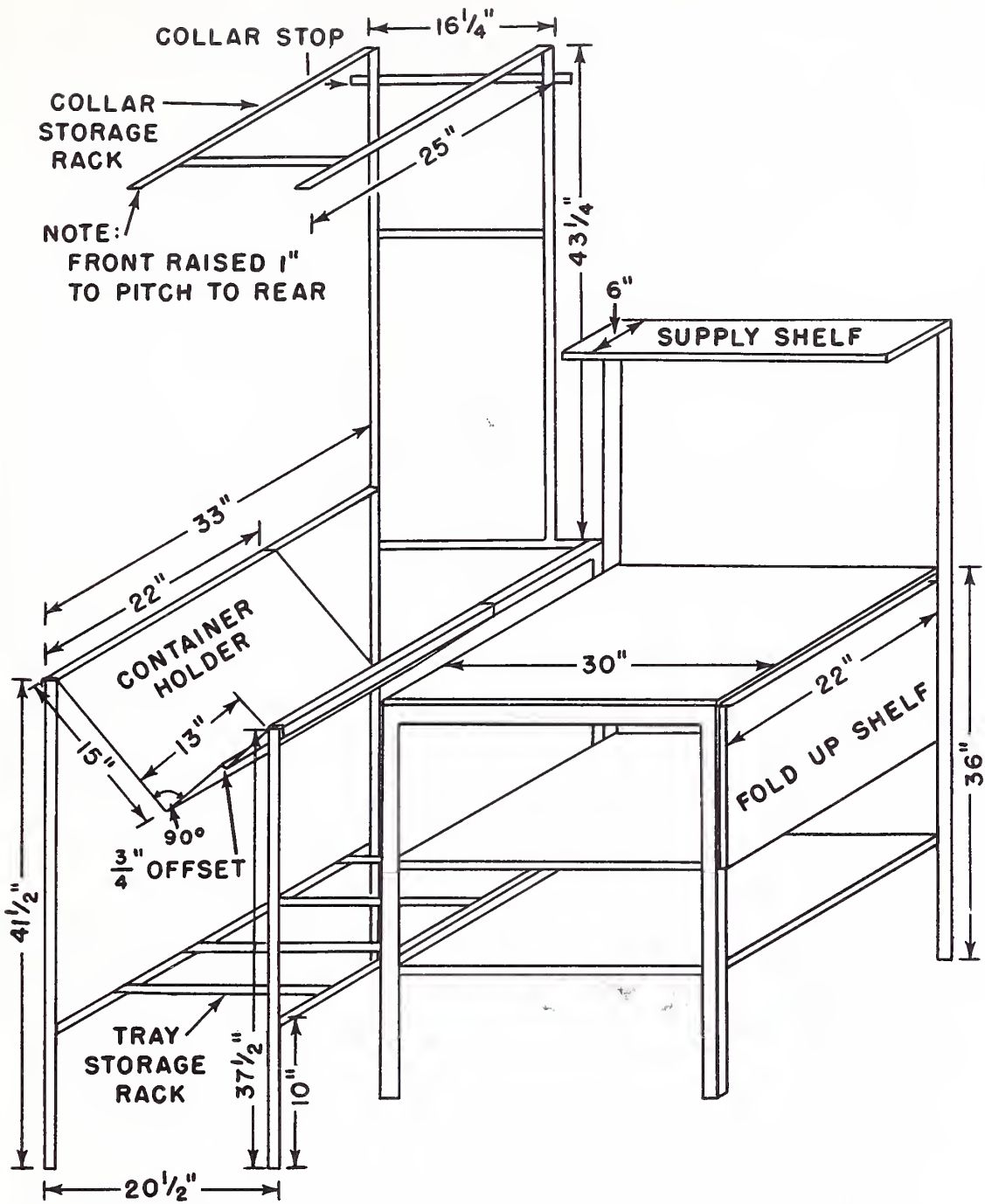
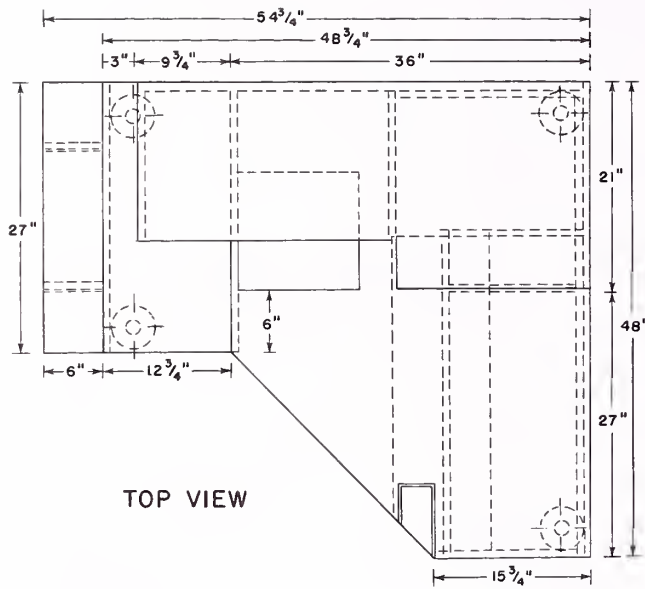

Figure 24.--Workplace for preparation of trays of nontrim bulk produce for tray display.



TOP VIEW

FILM HOLDER

24 ST ALUMINUM OR EQUIVALENT
5 REG. FOR PRODUCE TABLE
VARY TO FIT FILM SIZE

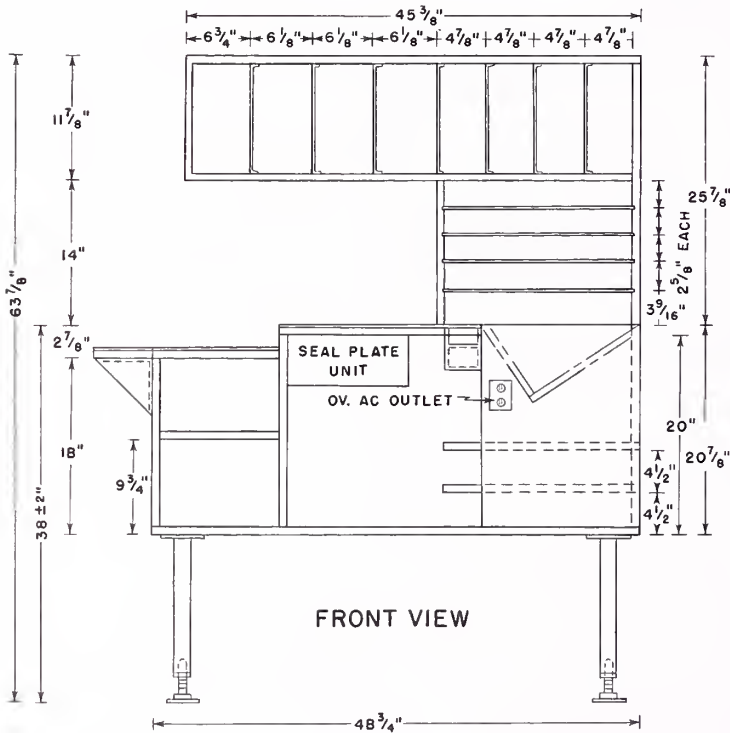
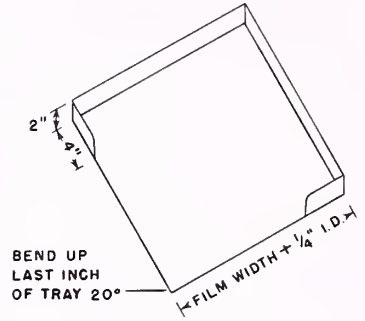

FRONT VIEW

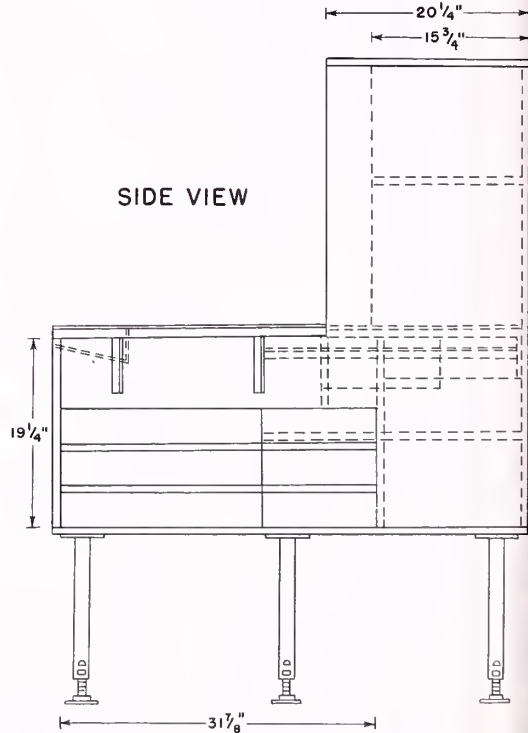

SIDE VIEW

Figure 25.--Workplace for preparation of prepack produce or bulk produce for tray display.

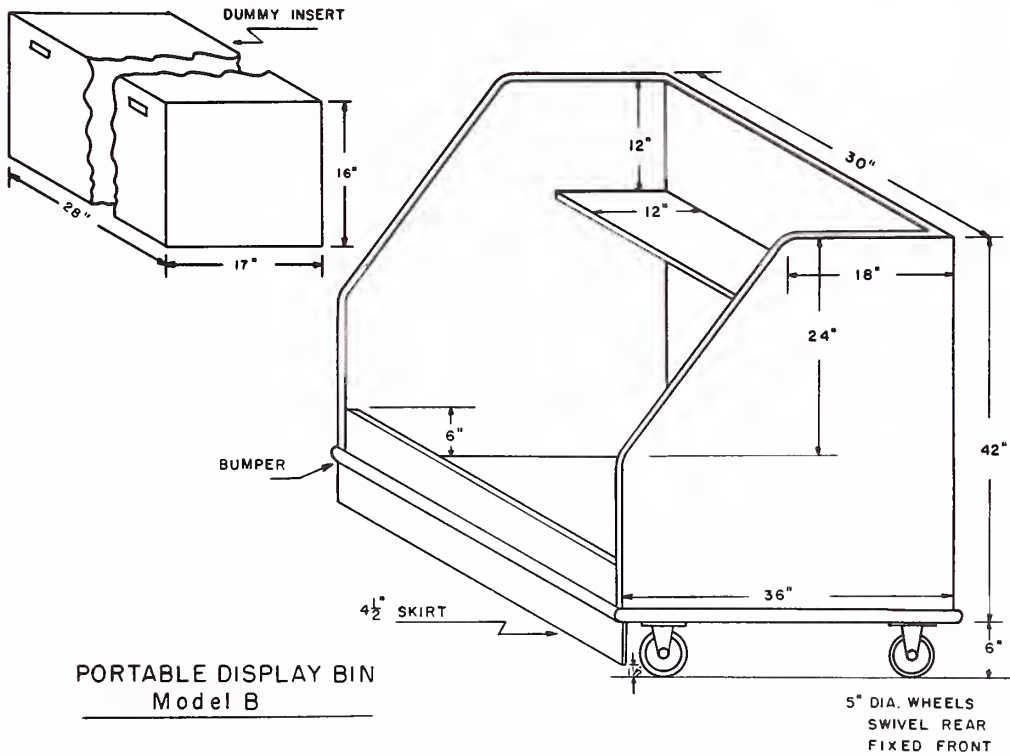
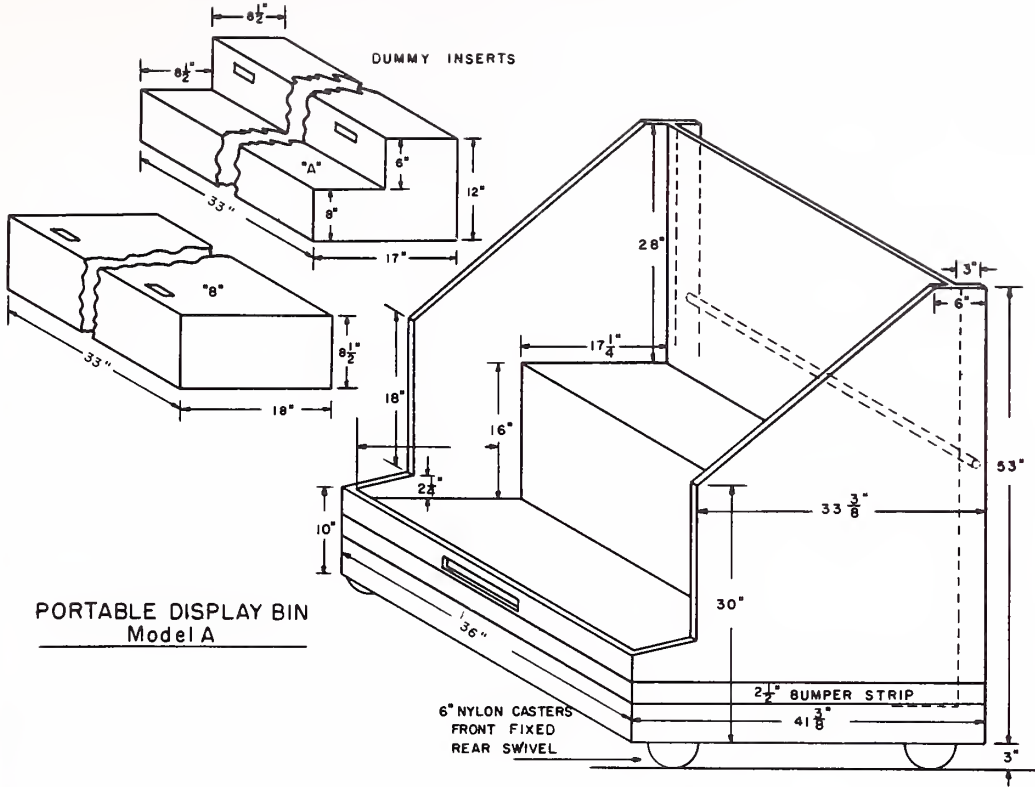

(NOTE: THIS DRAWING SHOWS ONLY CONFIGURATION AND DIMENSION)

Figure 26.--Mobile display bins for display of bagged produce items.



Growth Through Agricultural Progress

