



AgEcon SEARCH
RESEARCH IN AGRICULTURAL & APPLIED ECONOMICS

The World's Largest Open Access Agricultural & Applied Economics Digital Library

This document is discoverable and free to researchers across the globe due to the work of AgEcon Search.

Help ensure our sustainability.

Give to AgEcon Search

AgEcon Search

<http://ageconsearch.umn.edu>

aesearch@umn.edu

*Papers downloaded from **AgEcon Search** may be used for non-commercial purposes and personal study only. No other use, including posting to another Internet site, is permitted without permission from the copyright owner (not AgEcon Search), or as allowed under the provisions of Fair Use, U.S. Copyright Act, Title 17 U.S.C.*

No endorsement of AgEcon Search or its fundraising activities by the author(s) of the following work or their employer(s) is intended or implied.



Historic, archived document

Do not assume content reflects current scientific knowledge, policies, or practices.



84 Mr

3

PACKAGING AND DISPLAYING MEATS IN SELF-SERVICE MEAT MARKETS

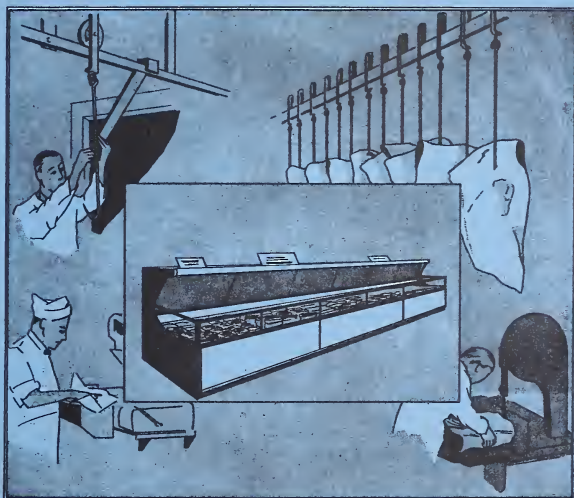

UNITED STATES DEPARTMENT OF AGRICULTURE

Production and Marketing Administration

Washington, D.C.



ACKNOWLEDGMENTS

The study of the meat operation in retail food stores was conducted in cooperation with Colonial Stores, Inc., the Kroger Company, and Franklin Supermarkets of Atlanta, Ga. The authors express their appreciation to these organizations and to their employees for their assistance in the conduct of the study. Special credit is due John W. Coleman and Joseph W. Hatch of Colonial Stores, Inc., Atlanta, Ga., and Joseph Gowland of the Kroger Company, Cincinnati, Ohio, for their valuable services.

Credit is also due the following: Dan F. Eubanks, George W. Waters, W. C. Moseley, A. C. Parnell, Edward B. Rowe, and T. W. Kehoe, of Colonial Stores, Inc., Atlanta, Ga.; Walter Fitzgibbon, William Gross, James Bey, R. D. Hardesty, J. B. Hassell, Jack Wright, Frank S. Vamos, G. W. Richardson and Gene Stagnaro, of the Kroger Company, Cincinnati, Ohio; and F. A. Williams, Ray Ecabert, D. G. Evans, and D. L. Thornton, of the Kroger Company, Atlanta, Ga.; and to the many persons in industry who aided in the conduct of the study, especially L. P. Reddy, Film Department, E. I. DuPont de Nemours & Co., Inc.; Bob Mosher, formerly of the Films and Flooring Division, Goodyear Tire and Rubber Company; Jack Aylward, National Cash Register Company; L. P. Bondurant, Hobart Food Machines; John A. Otte, Sanitary Scale Company; and Thomas P. Keefe, Toledo Scale Company.

- ooOoo -

The study on which this report is based was conducted under authority of the Agricultural Marketing Act of 1946 (RMA, Title II).

CONTENTS

	Page
Summary	iii
Introduction.	1
Time requirements and costs for packaging	4
Packaging methods	7
Boarding and trayng.	7
Obtaining film and positioning for wrapping	7
Wrapping and sealing.	11
Packaging equipment and workplace arrangement	24
Principles.	24
Wrapping table construction	24
Location of a seal plate in wrapping station.	28
Packaging films	30
Proper handling and storage	30
Yield	31
Labor productivity.	33
Reject packages	34
Film cost comparisons	35
Selection of proper size wrapping materials	38
Pricing methods and costs	43
Pricing equipment and workplace arrangement	49
Scales	49
Tare adjustment	52
Labeling machine.	54
Workplace arrangement for weighing and pricing.	61
Self-service market display	64
Results of applying improved methods, materials, and equipment in two test stores.	69
Methodology	70
Appendix	72

SUMMARY

The labor necessary for packaging and displaying meats in retail food stores that have self-service meat markets accounted for more than half of the total man-hour requirements in the markets studied. Motion and time study techniques were used to measure productivity of these functions as they were performed. An attempt was then made to increase productivity in each operation through the development of improved handling methods, equipment, and layouts in the meat departments.

The application of selected improvements, in methods, materials, and equipment, to the packaging and displaying of meats in two typical self-service stores increased the productivity of these operations 10 and 23 percent respectively, in these stores and effected a saving of 10.6 and 31.2 man-hours per week, respectively. In addition, materials costs were reduced \$19.08 and \$10.20 per week in the two stores studied.

Wrapping methods that proved to be most advantageous included the following: (1) Applying a board or tray, if required, to each package as the package is wrapped; (2) purchasing wrapping film in roll form and presheeted to the proper sizes in the market; (3) storing sheeted cellophane in trays that turn up the front edge of the film pack, or in racks which provide a vertical support over which the film is positioned. Sheeted pliofilm should be stored in open-front trays provided with spring-loaded clips for holding the film in place; (4) using the diagonal wrap instead of the square wrap, as the latter method requires from 15 to 62 percent more film; (5) using the hand iron rather than the seal plate when proper sizes of cellophane are used; and (6) holding the hand iron in the hand while the various folds are being made in wrapping a package. Laying the iron down between seals requires 10 percent more time.

Principles to be followed in setting up a wrapping station were developed and from these principles a wrapping table was designed which pre-positioned all tools, materials, and working surfaces within easy reach of the operator. When the new table was used, the work was less fatiguing and a little faster than when the conventional tables were used.

It cost less to package meats in sheet cellophane than in sheeted pliofilm or roll pliofilm at the film prices prevailing when the study was made. (As used in this report, the term "sheet" material applies to wrapping material bought already cut into sheets; and "sheeted" material to wrapping material bought in rolls and cut into sheets at the retail store.) The pounds of meat wrapped per pound of film used were considerably higher for pliofilm than for cellophane, owing to the fact that the number of square inches per pound of pliofilm was greater than the number of square inches per pound of cellophane. On the other hand, labor productivity was greater and the film cost per package was lower with sheet cellophane than with sheeted pliofilm.

Studies of rewrips showed that the greatest number of torn and leaky packages were found when cellophane was used and the greatest number of discolored packages when pliofilm was used, but that the greatest cause of rewrips was inaccuracy in anticipating consumer demands.

The installation of proper sizes of boards, trays, and cellophane in two markets resulted in a saving of 8 percent in board and tray costs and a 19.4 percent saving in film. Boards and trays were selected that did not overlap the meat, and film sizes were selected so that the film had a 1-inch overlap on an average size package. Time studies indicated that there was a slight increase in packaging production per man-hour when these new materials were used.

A new type of table on which meat was placed for pricing was developed. It improved handling methods, increased productivity, and reduced fatigue. This table pre-positioned all tools and materials within easy reach of the operator. The most productive method for pricing even-weight packages received in the store already packaged was to use a self-inking stamp set with a quick-drying ink.

The cost of processing previously wrapped items was about one-fourth of the cost for meats prepared and packaged in the store. The selling prices, direct costs, and margins in one store for handling three luncheon meat items, purchased both bulk and packaged, indicated that by purchasing some items prewrapped and other items in bulk form, returns could be increased.

Superior scale readability, good selection of prices per pound, and fast balancing of one of the four prepackaging scales tested gave the one scale a considerable advantage in productivity and accuracy over that of the other three scales. On the basis of a survey of the most common prices found in meat markets, it was ascertained that the price plates of the four types of scales tested had from 75 to 99 percent of the number of price observations in the survey. A device for simplifying the setting of the tare on prepackaging scales proved convenient and increased production.

Two labeling machines tested proved profitable when 2,000 or more packages per week were handled. The separate label-printing machine combined with a conventional scale provided a saving in label costs, and in addition reduced labor costs more than did the combination scale and label printer. Both machines increased operator productivity over the conventional operation, and they provided more legible labels which reduced the error in the reading of prices at the checkout counter.

A considerable amount of time may be saved in the display of meat by increasing the number of units handled per trip to the display cases. In one of the test stores where full pan loads were not carried, the time required for performing the display operation was decreased 25 percent by handling full loads instead of following the former practice.

By Edward M. Harwell, Dale L. Anderson,
Paul F. Shaffer, and Robert H. Knowles,
agricultural marketing specialists,
Marketing and Facilities Research Branch,
Production and Marketing Administration

INTRODUCTION

The number of independently owned and operated stores with complete self-service meat departments increased 57 percent in number during 1952, according to trade estimates. 2/ The same type of stores with partial self-service meat departments increased 17 percent in number during the same period. The increasing popularity of the self-service method of merchandising meat has focused attention on developing efficient methods of handling meat by this method.

Since direct labor and packaging materials costs averaged between 50 and 60 percent of the total costs of selling meat in the two stores studied, these items of expense were made the subject of research. Studies were made of the major functions in retail meat markets for the purpose of finding ways to increase the productivity of labor and to reduce the cost of packaging materials by improving methods, materials, equipment, and layout in the stores. Reduction of handling costs makes the individual retailer more competitive with other markets, lowers retail prices, increases sales volume, and makes it possible to increase wages because of increased productivity.

The methods and equipment used in a number of stores of several different food chains in various parts of the country were examined

1/ This report is the second part of an over-all study on handling meats in retail food stores. The first part, "Receiving, Blocking and Cutting Meats in Retail Food Stores," was an analysis of those operations in service and self-service meat markets. Subsequent reports are planned, covering such subjects as new packaging materials for self-service meats, customer service and display in service meat markets, and the effect of layout and other improvements on meat market operating costs.

This study is the third on handling operations in retail food stores. The first study, "The Check-out Operation in Self-service Retail Food Stores," was published in January 1951; the second, "Some Improved Methods of Handling Groceries in Self-service Retail Food Stores," in May 1952. .

2/ "Highlights of U. S. Food Retailing in 1952." The Progressive Grocer, March 1953.

before detailed studies were made. Close examinations of the operations in 52 stores of 3 firms in the southeastern part of the country were made and 26 stores were selected for detailed studies. Data developed for the purpose of comparing different methods of performing an operation were shown in detail only for those elements that were affected by the changes. The time requirements to perform the other elements were held constant. (The procedures used and the types of data collected are explained under "Methodology" on page 70.)

Four retail stores, representative of the 26 selected for detailed study, were analyzed to determine the relative amounts of time required to perform the various functions in the meat departments. Table 1 shows the results of these studies for a 100-percent self-service meat market, and for a 90 percent self-service meat market. The remaining 10 percent of business in the latter type of meat market consisted of fresh poultry and fish which were sold over a service counter.

Table 1.--Percentages of total market time required for the handling operations in retailing meats in two self-service meat markets in a southeastern city

Handling operation	Percentage of total market time in--	
	100-percent- self-service market	90-percent- self-service market
	Percent	Percent
Receiving	0.9	2.7
Blocking	1.3	1.0
Retail cutting	29.5	25.1
Packaging	37.2	27.4
Display	14.4	13.0
Customer service	2.9	13.6
Clean-up	6.3	6.0
Personal and fatigue	1.3	4.5
Ordering	1.0	1.6
Miscellaneous	5.2	5.1
Total market time.	100.0	100.0

The principal difference in labor requirements occurred in the packaging and customer service functions. Table 1 shows that the packaging and displaying of self-service meats accounted for more than 50 percent of the total labor requirements in a 100-percent self-service market, and more than 40 percent of the total labor time in a 90-percent self-service market.

Packaging, as defined in this report, consisted of wrapping and pricing retail cuts of meat. These operations took place after the

retail meat-cutting operation and before the product was temporarily stored or displayed. Packaging usually started when the meat cutter gave the meat or pan of meat to the wrapping station, and the operation ended when the packages were replaced on the pan after pricing. Appendix table 30 shows a production standard for packaging T-bone steaks, and indicates the method used to prepare production standards for the packaging operation.

Wrapping involved that part of the packaging operation that took place after the meat cutter transferred the meat to the wrapping station and continued until the wrappers disposed of the product prior to the weighing and pricing operation. However, in the case of inside labels, the pricing often took place before the wrapping operation. The attaching of outside labels was considered a part of the wrapping operation and the attaching of inside labels was considered a part of the weighing and pricing operation. Boarding and traying were included in the wrapping operation when performed by the wrapper. When the meat product was put into trays by the meat cutter, this function was included as part of the cutting operation.

Pricing included the weighing and price-marking of the product, or just price-marking it, in the case of some constant weight items received in the store already packaged, and applying the label if this had not been done previously.

The display operation included carrying the meat from the scale tables to the display case or holding cooler and from holding cooler to display case, arranging the packages in the case, rearranging the packages in the case, and removing out-dated, discolored, torn, or leaky packages and returning them and the empty pans to the cutting or packaging area. Appendix table 31 shows a production standard for displaying T-bone steaks, and indicates the method used to prepare production standards for the display operation.

TIME REQUIREMENTS AND COSTS FOR PACKAGING

Detailed studies of the packaging operation were made in 11 stores of 3 companies. For typical operations of these three companies, the wrapping of the package required about 50 percent of the packaging time, the pricing required about 25 percent, and the remaining 25 percent of the packaging time was used in movement to and from workplaces, in moving the product from one place to another, or in such miscellaneous jobs as coding labels or preparation of materials or workplaces.

The stores studied had considerable time differences due to differences between firms with respect to methods used in weighing and wrapping, care used in wrapping, equipment, and workplace arrangement. Table 2 shows data for meat items which illustrate typical differences. Since average weight of packages affects wrapping time, the time requirements were taken for packages of similar average weights.

Table 2.--Time requirements per package for packaging specified meat items of similar average package weights in self-service markets in each of two firms

Meat item	Firm I		Firm II	
	Average	Time per	Average	Time per
	package	package	package	package
	weight	weight	weight	weight
	Pounds	Man-minutes	Pounds	Man-minutes
Stew beef	0.97	0.742	0.94	^{1/} 0.620
Half round beef79	.642	.77	.845
Boneless rib steak70	.603	.69	.914
Chuck roast	2.68	.834	2.85	1.078
Ham slices72	.552	.69	.772
Luncheon meat sliced.44	.380	.49	.605

^{1/} This time is low because stew beef was trayed as part of the cutting operation in this store and was not included in packaging time.

Packaging labor and materials costs for items wrapped in the stores were about 2½ cents a package (table 3). This included the cost of boards and trays where they were used. Labor and materials costs varied according to the nature of the meat product that was packaged. For example, some items do not require boards or trays. When the boards or trays were used they represented a cost about equal to that of the film cost (fig. 1).

In all stores some items, such as 1-pound packages of bacon and sausage, were received already wrapped and labeled. Luncheon meat also was received in some stores already wrapped. The cost of pricing these packages was about 0.3 cent per package.

Table 3.--Labor and materials costs per package for packaging meats in sheet cellophane, in self-service markets in each of two firms

Labor and material cost	Firm I		Firm II	
	Cost per:	Percentage of:	Cost per:	Percentage of:
	package:	total cost	package:	total cost
	<u>Cents</u>	<u>Percent</u>	<u>Cents</u>	<u>Percent</u>
Board or tray costs . . .	0.480	18.24	0.420	16.90
Film costs864	32.83	.710	28.50
Packaging labor costs . .	1.288	48.93	1.360	54.60
Total labor and materials:				
costs	2.632	100.00	2.490	100.00

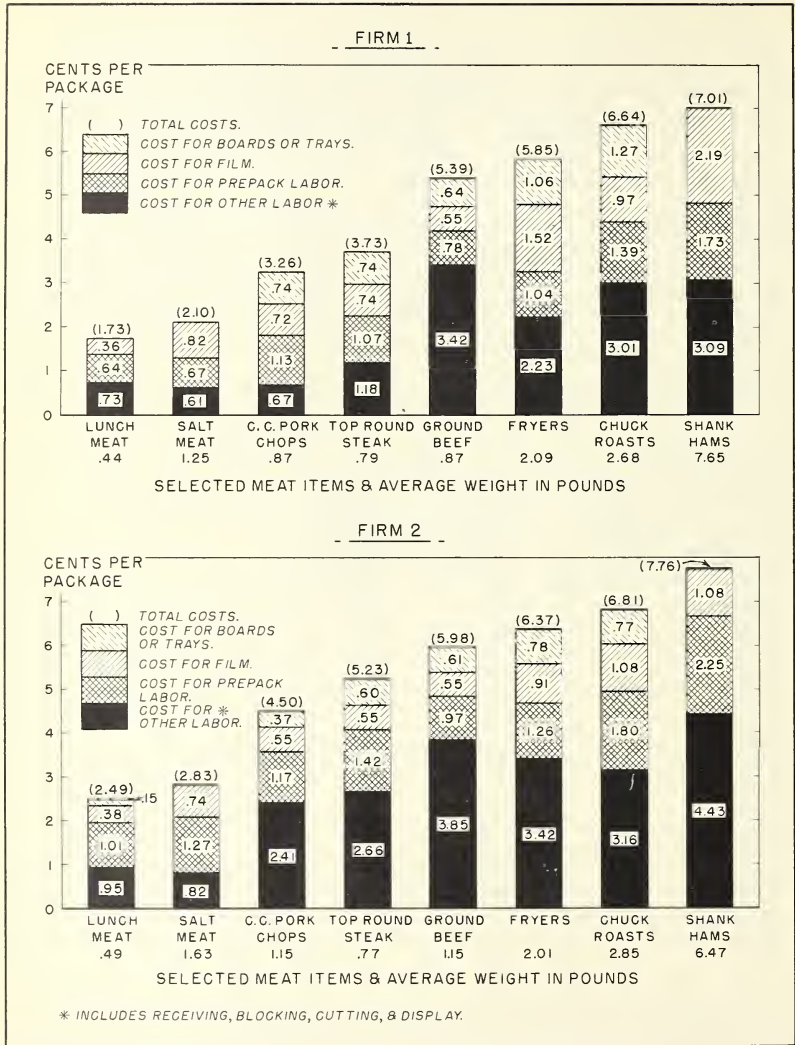

Figure 1.--Direct market costs, in cents per package, for packaging selected meat items in self-service stores of Firm I and Firm II.

PACKAGING METHODS

Boarding and Traying

Boarding and traying of the meat, where this was done, was performed in three different ways: (1) Some trayed items, such as fryers and ground beef, were trayed by the meat cutters during the cutting operation; (2) boarding and traying of the meat in the prepackaging operation was sometimes done as a separate operation from the wrapping; and (3) many operators boarded each package of meat as they wrapped it.

Boarding the meat before wrapping it has the advantage of allowing the operator to do a messy job first. It is easier to keep the hands from getting soiled or greasy when wrapping previously boarded meat. Boarding meat as a separate operation, before wrapping, has the following disadvantages: (1) Meat boards tend to get bloody and discolored, especially if the meat is stacked, and the product acquires an undesirable appearance; (2) separation of operations decreases productivity because of additional handling of the meat; and (3) not all items lend themselves to separate boarding, since the board will not stay on the package without the wrapping material (for example, pork loin roasts when a 4" x 4" board is used). Therefore, the best results were noted when the product was boarded or trayed as it was wrapped.

Obtaining Film and Positioning for Wrapping

Roll Stock Film Methods

Roll stock wrapping film may be handled in three ways: (1) The operator may tear off each sheet of film as needed; (2) the operator may tear off enough sheets to wrap a particular pan of meat and position each sheet as needed; and (3) a sheeter (a device for cutting roll film into sheets) may be provided and the operator may presheet the film in different sizes and store the sheets in trays, positioning each sheet as needed. As indicated, a study of the comparative time requirements to get the film and position the meat on it for wrapping showed that the slowest time represented that for tearing off several sheets from the roll and then wrapping the packages. The reason for this slowness was that the film had to be handled twice. The difference in time between tearing each sheet from the roll as needed and presheeting the film was not significant. Studies indicated that for the former method highly skilled operators were necessary in order to obtain a film yield equal to that for the presheeted film; therefore, presheeting the film would probably be most advantageous for the average operator. (See Appendix table 24.) The time required for the three methods of handling roll stock film was as follows:

<u>Method</u>	<u>Time requirement</u>
	<u>Man-minute</u> <u>per sheet of film</u>
Tearing each sheet from roll as needed and positioning meat on film	0.142
Tearing off several sheets from roll and placing on table, plus positioning meat and film169
Using presheeted film (including sheeting time) obtaining and positioning meat and film148

Distance From Film Supply to Work Place

The distance the hands must travel in order to obtain the film is important when each sheet of film is obtained for the wrapping operation. The farther the film tray is from the workplace the more reach or travel is required, and the harder it is for the operator to grasp the film. Tests were made in one market by placing the trays one above the other in a rack in front of the wrapping station, and the time to get the film from the trays and position it on the table one sheet at a time was studied. It required almost twice as long to obtain and position film from trays 21 inches above the table as from trays at table level. The time required with the tray at various heights was as follows:

<u>Height of tray</u> <u>above table</u>	<u>Time in man-minute to</u> <u>obtain and position</u> <u>film per sheet</u>
0 inches	0.044
7 inches060
14 inches062
21 inches076

Type of Sheet Film Container

Most operators pinch the film in the tray and lift out the top sheet. Other operators peel the sheet of film away from the corner of the pack of film. Regardless of the method used there is usually considerable fumbling in the grasping of film.

One difficulty encountered in pinching the film in the center of the sheet was that in bringing the sheet to the wrapping place it tended to fold, and the operator had to shake it to flatten it or use both hands to separate the fold. In all methods, the greatest difficulty in grasping the sheet was that the operator's fingers became greasy. When products that tend to get the hands greasy are being wrapped, a towel should be

provided to keep the hands, or at least the forefinger and thumb, clean. The rubber thumb was found to aid in grasping the film.

The grasping of the film is easier, also, when the film tray is made 1 inch shorter than the film it is to hold. When the film is placed in the tray it is curled upward at the front of the tray so that the operator may readily separate the sheet of film from the pack. This type of lip tray was tested by two operators, and a comparison was made by pinching the film from a regular tray and pinching the film from a batch placed on the table (fig. 2). The lip tray enabled the operator to do the job approximately 10 percent faster than with the next best method tested (table 3).

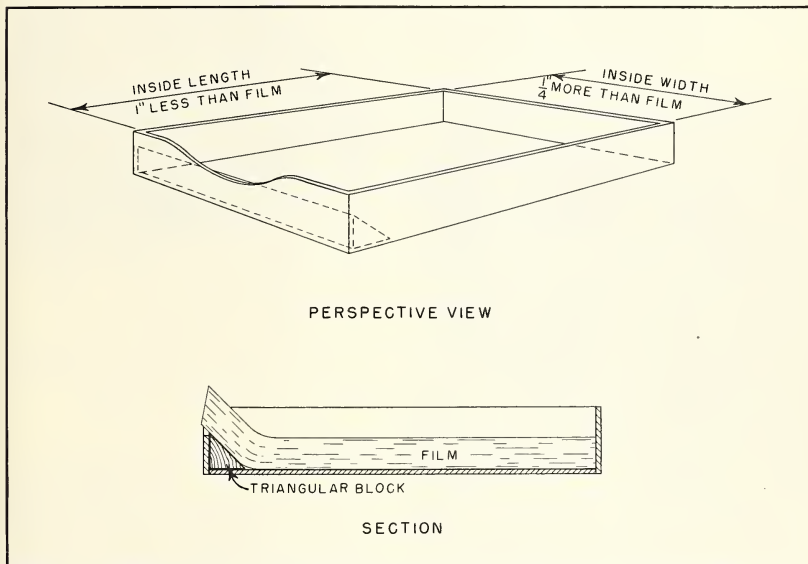

Figure 2.--Standard lip tray adapted to aid in the grasping of meat-wrapping film.

Table 3.--The time required by operators A and B to grasp film from the lip tray compared with the time required by two other standard methods of grasping the film

Operator	Film size	Pinch film sheet	Pinch film sheet	Pull film sheet
		from batch on table and position	from conventional tray and position	from lip tray, and position
		for wrapping	for wrapping	for wrapping
	Inches	Man-minutes	Man-minutes	Man-minutes
A	13 x 14	0.045	0.050	0.041
B	11 x 12	.043	.042	.037

In order to store film more advantageously a film holder or tray was developed in which cellophane was stored by hanging it over a center support (fig. 3). In this position the film hung free and there was less tendency

for the pieces to stick together. The principal gain from the use of this film holder was in conserving space--all the film sizes necessary in a wrapping operation being stored on one table in an area easily accessible to the operator. The operator grasped the film from the top of the tray or holder but it was found that the best method was to peel the film away from the end of the tray with the thumb. The time necessary to obtain the film with this holder was the same as that for the lip-type tray.



Figure 3.--Tray to store cellophane folded over a central support.

The best method found for handling sheeted pliofilm was to use front trays with spring-loaded needles at the back to pin the film down (fig. 4). By the use of this method each sheet of film could usually be pulled from the other without the film sticking together. ^{3/} One minor difficulty

^{3/} Sticking together of sheet pliofilm was a major difficulty in using this film. The use of slip sheets of tissue paper between each sheet of film was tried but that was expensive and it slowed the wrapping operation. It is understood that a method has been developed whereby pliofilm can now be purchased in sheets with little or no tendency to stick together.

encountered in using the open-front tray for holding sheeted pliofilm was that small pieces of film remained on the needles and eventually prevented the points from penetrating further down into the sheeted film, and the occasional tendency of the entire batch of film to slide from the tray. The trays were designed to be arranged in tiers of four with the largest tray on the bottom. The disadvantage of this arrangement was that the largest and the least used size of film was at the bottom and the smallest and most used size of film was at the top--farthest from the operator. By inverting the order of the racks and putting the smallest size on the bottom the operator would have the frequently used film sizes closer to hand and, in addition, would gain table-top work space.

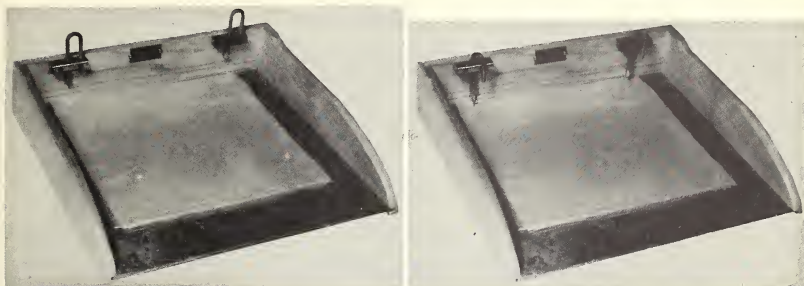

Figure 4.--Film tray for holding sheeted pliofilm.

Wrapping and Sealing

Several different wrapping methods were used in the stores studied. Usually an operator will develop a given method for a given product and will not vary the method from package to package. In this study the methods used are classified according to the following different factors: (1) The way the meat is placed on the film (square or diagonal); (2) the way the iron is held between seals and laid down; (3) the number of folds used before sealing the package, the number of seals, and the effect on these of size of film; and (4) the sealing equipment used. Usually the higher the skill of the operator the larger is the number of folds before sealing and the smaller the number of seals.

Comparison of Square and Diagonal Wrap

The square wrap consists of placing the meat on the film so that the edges of the film are parallel with the edges of the package. The opposite sides are then turned up and sealed. It was often necessary to make a tuck in the ends before they were turned over and sealed. Some operators used this method without turning the package over. The square-wrap method has four disadvantages: (1) More film is required on all but long, narrow packages; (2) in order to get the best use of film it is necessary to provide more sizes of film; (3) in order to get the best use, oblong sizes of film must be provided that require the operator to exercise more care in positioning the meat on the film; and (4) wrapping the package square requires about 5 percent more time than does the appropriate similar method that makes use of the diagonal wrap.

The time required to package a rib steak on a 5" x 7" board with a 10" x 11" sheet of cellophane with the square wrap was 0.662 man-minute per package, compared with 0.627 man-minute by the diagonal wrap. Comparison of the wrapping of a number of representative items with both the diagonal wrap and the square wrap indicated that from 15 to 62 percent more film was required for the square wrap in order to get an equally tight package (table 4). As the package gets thicker the advantage of the diagonal wrap increases, but this advantage decreases as the package gets longer and narrower.

Comparison of Holding with Laying Down the Hand Iron Between Seals

The types of hand irons used in this study are shown in figure 5. Two methods of sealing are commonly used:

1. Diagonal wrap using three seals with the hand iron and laying the iron down between seals. Under this method the operator gets the film (cellophane or pliofilm) and places it on the table and then gets the meat and places it on the film. If the meat is to be boarded, the board is placed on top of the meat. The meat and board are placed diagonally on the film. The operator then turns up two opposite sides of the film (grasping the film at the corners), usually the long sides first, and folds one under the other against the backing board. If one corner of the top fold hangs over, it is often folded back at this point. The operator then grasps the sealing iron with one hand while holding the package with the other hand and seals these two corners of the film. He then lays the iron down and, with two hands, turns up another corner of the film and folds it against the board. The iron is obtained with one hand while the package is held with the other hand, the corner is sealed, and the iron is put down. Again the operator folds the last corner of the film with two hands, grasps the iron, and seals the corner down. At this point the operator may get an unmarked label and seal it to the package before disposing of the iron and the package. This method is illustrated in figure 6.

Table 4.--Comparative cellophane film size requirements when using a square wrap and a diagonal wrap for the same packages with a 1-inch overlap 1/

Cellophane-wrapped item	Weight : of : package:	Dimensions of package : Inches	Film requirement for square wrap		Film requirement for diagonal wrap		Additional film required for square wrap	Percent
			Dimension : Inches	Area : Sq. in.	Dimension : Inches	Area : Sq. in.		
Pickle and pimento (sliced)	0.48	4-3/16 x 4-5/16 x 3/4	11-3/8 x 8-1/2	96.69	9 x 9	81	19.37	
Half round steak70	7-1/16 x 4-3/16 x 3/4	10-3/4 x 12-1/4	131.69	10 x 10	100	31.69	
Fryer (cut up)	2.06	8-1/2 x 5-5/8 x 2	14-1/2 x 14-1/2	210.25	13 x 13	169	24.41	
Chuck roast	3.5	9-7/8 x 6-3/8 x 1-3/4	16-5/8 x 16	266.00	15 x 15	225	18.22	
Bologna (sliced)41	4-1/8 x 4-1/8 x 7/8	11-1/2 x 9	103.50	8 x 8	64	61.71	
Hamburger	1.00	5-3/8 x 5-3/8 x 1-5/8	14-1/4 x 11	156.75	10 x 10	100	56.75	
T-bone steak78	7-3/16 x 5-1/8 x 3/4	10-3/4 x 11	118.25	10 x 10	100	18.25	
Pork chop	1.33	9 x 6-1/8 x 1-1/4	15 x 13	195.00	13 x 13	169	15.38	
			(butterfly package)					

1/ One-inch overlap on the folds except on the ends of the square wrapped packages where 1-1/2 inch overlap was necessary.



Figure 5.--Types of hand irons used in sealing meat packages.

2. Diagonal wrap using three seals with the hand iron and holding the iron between seals. In this method the operator follows the procedure as outlined above, except that once the iron is obtained it is held in the hand while making the second and third folds.

A comparison of the two methods, using three seals with sheet cellophane, indicated that holding the iron between seals was about 10 percent faster than when the iron was laid down between seals (table 5). There was a better distribution of work load when the iron was held between seals than when it was laid down, since in the latter method much of the work was done with one hand.

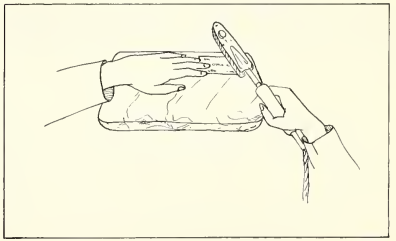
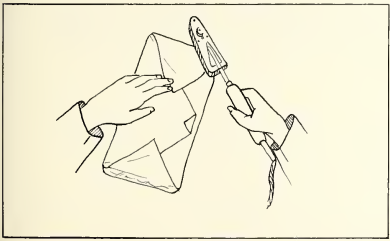
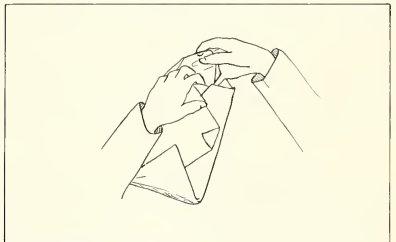
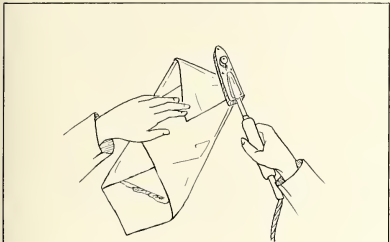
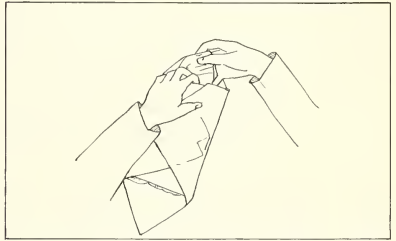
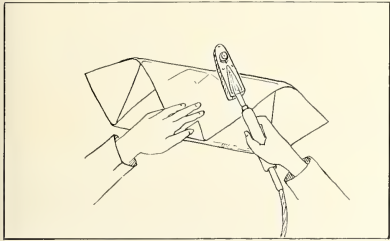
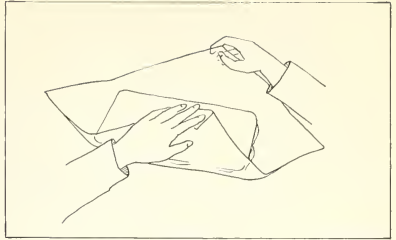
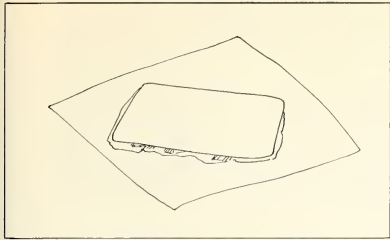

Figure 6.--Steps in wrapping a package of meat diagonally, using three seals with the hand iron and laying the iron down between seals.

Table 5.--Comparison of time required to wrap, seal, and dispose of packages when iron was laid down after each seal and when iron was held until all seals were made

Meat item	Average	Time to wrap, seal, and dispose of package		Percentage of
	package weight	Iron laid down	Iron held	time saved by holding the iron between folds
	Pounds	Man-minutes	Man-minutes	Percent
Ground beef	0.97	0.151	0.131	13
Chuck roast	3.31	.245	.229	7
Half round steak	1.04	.176	.148	16
Jiffy steak64	.151	.143	5
Ham slices53	.214	.180	16

Effect of Folding and Sealing Methods and Film Size on Productivity and Costs

The time required to wrap a given type and size of package varied considerably from one study to another. One of the principal factors causing the time variance was the film size. In order to determine the effect of this factor, studies were made of the time required for the operation (obtaining the film and meat, wrapping, sealing, and disposing of the package) using different sizes of cellophane for wrapping the same item. The package weight was held constant, as was the item wrapped, and the film size was varied in 1/2-inch increments (9" x 9", 9-1/2" x 9-1/2", 10" x 10", and so on). Comparisons were made with the three-seal hand-iron method, holding the iron, and the following hand iron methods:

1. Diagonal wrap using two seals with the hand iron and holding the hand iron between seals. In this method the operator uses the procedure outlined under the previous heading, except that three sides of the film are folded down before the iron is obtained and the first seal made.

2. Diagonal wrap using one seal with the hand iron. In this method the operator uses the procedure outlined in the previous methods, except that four sides of the film are folded down before making the first and only seal.

As the film size increased, the time per package decreased at first and then increased. This time variation for the three methods increased as the number of seals required by the method decreased. The relative time required to wrap and seal a package by the three methods reversed between large and small film sizes (fig. 7). The differences in film sizes used by the various firms probably explains the differences in opinion among the trade as to which is the best wrapping method. The smallest film size used in these studies was the smallest in which the product could be satisfactorily wrapped. The most economically wrapped package

MAN-MINUTES
PER PACKAGE

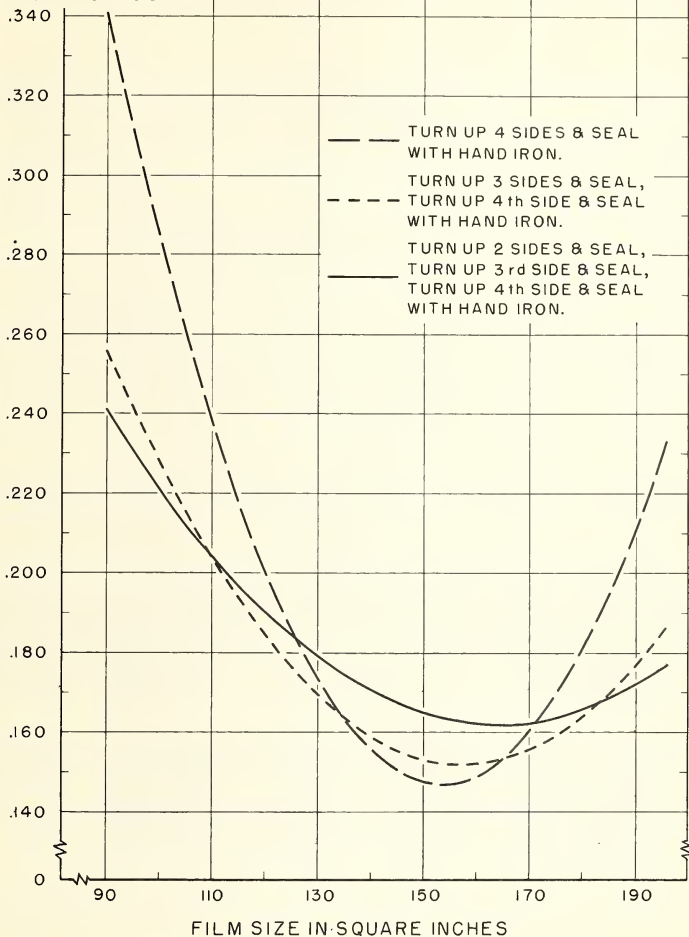

Figure 7.--Time required to obtain, position, wrap, seal, and dispose of ground beef packages in 5" x 5" x 1" trays wrapped in various film sizes and different wrapping methods using cellophane (average weight per package 1.14 pounds).

usually resulted when a sheet of film one to two sizes larger than the smallest size was used. In general, the results for pliofilm were found to be the same as those for cellophane, except that the size of film with pliofilm was not as important as with cellophane because pliofilm stretches. 4/

In order to determine the proper sizes of film to use, the costs of the film and the costs of the labor per package were plotted. The total packaging cost was used in order to indicate the effect of film size on total packaging costs. Considering both labor and materials, the most economical results were obtained by using the smallest size film which would give the package a good, tight seal (fig. 8). By using the smaller film sizes, there was little difference between methods in time required to wrap a package. From these studies, a general principle was developed for the selection of the proper size film, based on cellophane for a diagonal wrap. This principle calls for the selection of a film size with approximately a 1-inch overlap on the average size package of a given product. The studies indicated that the best wrapping procedure to follow is to use a method with more seals on large packages, and one with fewer seals on smaller packages within the same film sizes. For best results, however, sufficient film sizes should be provided to allow the selection of the best size to fit the package.

Comparison of Hand Iron and Seal Plate

The conventional type of seal plate used in this study is shown in figure 9. The following methods are the most commonly used with the seal plate:

1. Diagonal wrap using three seals on the seal plate. The operator positions the meat and board diagonally on the film, folds up two sides of the film and seals it on the seal plate. The operator brings the package back and folds up the third side and seals it, then brings the package back again and folds up the fourth side and seals it, and then disposes of the package.

2. Diagonal wrap using two seals with the seal plate. The operator positions the meat and board diagonally on the film and folds up two sides of the film, then folds up the third side and seals the package on the seal plate. The operator then brings the package back and folds the fourth side and seals it on the seal plate, and then disposes of the package.

4/ Figures 28 and 29 in the Appendix show the comparisons obtained when different sizes of sheet cellophane and pliofilm were used to wrap round luncheon meat items.

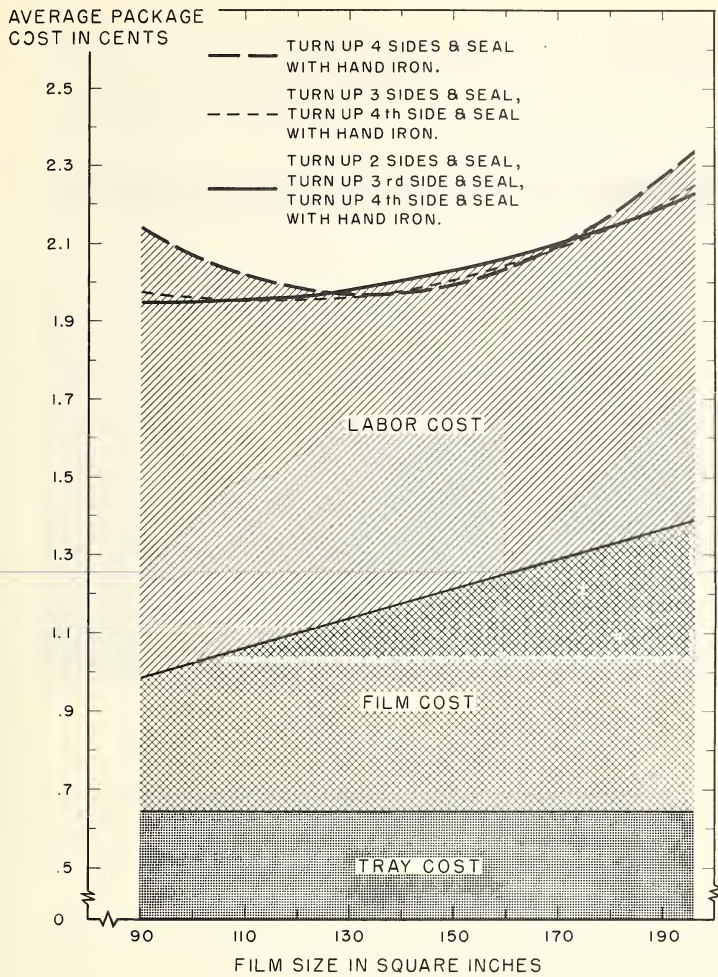

Figure 8.--Total packaging and pricing cost per package for ground beef in 5" x 5" x 1" trays wrapped in various film sizes and different wrapping methods using cellophane (average weight per package 1.14 pounds).



Figure 9.--Conventional seal plate for sealing meat packages.

3. Diagonal wrap using one seal with the seal plate. The operator positions the meat and board diagonally on the film, folds over two sides of the film, folds up the third side of the film, folds up the fourth side of the film, and then seals the package by sliding it over the seal plate.

The diagonal wrap, using one seal with the seal plate, was the only seal-plate method that was as fast as the hand-iron methods. This seal-plate method was faster only when film sizes that were excessively large in relation to the package were used (fig. 10). Considering the total costs of the film and labor, the hand iron was found to be advantageous as indicated in figure 11.

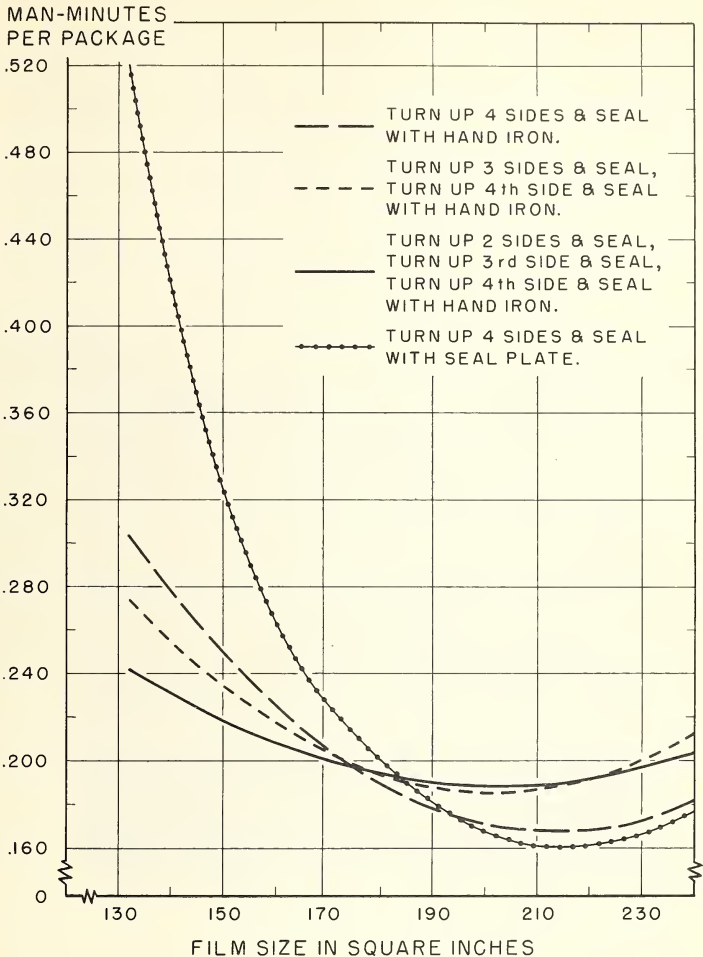

Figure 10.--Time required per package to obtain, position, wrap, seal, and dispose of pork chops on a 6" x 8" board wrapped in various film sizes and different wrapping methods using cellophane (average weight per package 1.05 pounds).

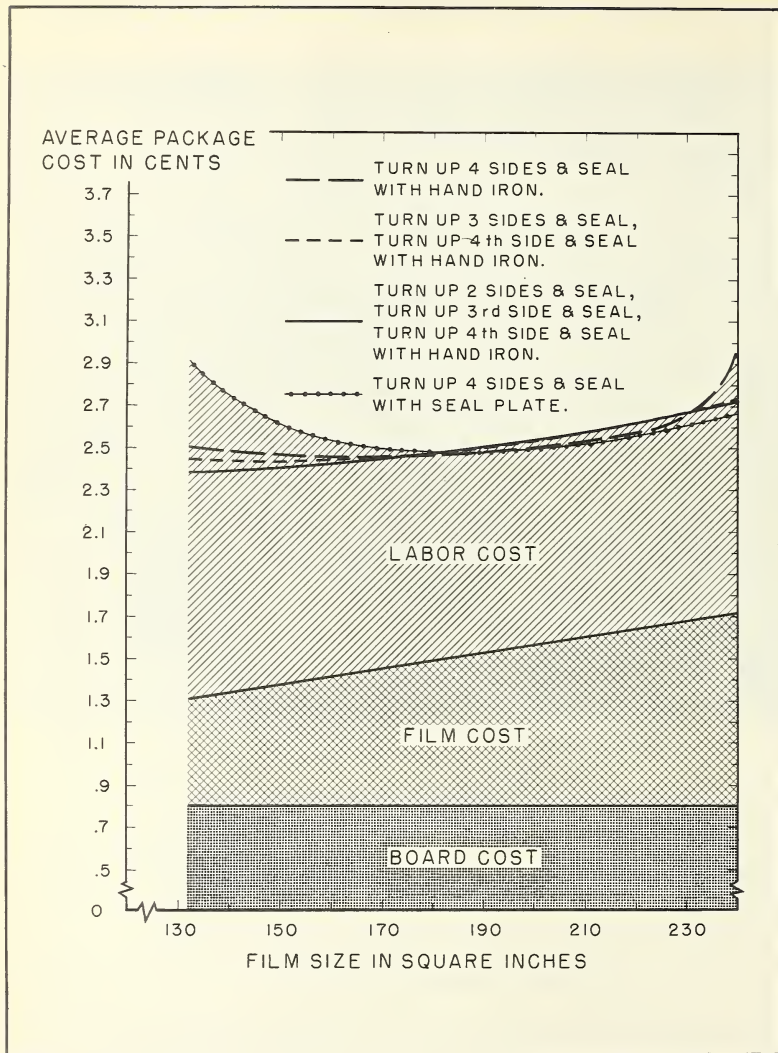

Figure 11.--Total packaging costs per package for pork chops on a 6" x 8" board wrapped in various film sizes and different wrapping methods, using cellophane (average package weight 1.05 pounds).

To summarize, the best packaging operation based on the methods tested may be obtained by:

1. Applying the board or tray (when required) to each package as the package is wrapped.
2. Providing a minimum number of film sizes that have been developed on the basis of the 1-inch overlap rule.
3. Storing cellophane in a lip-type tray or in a fold-over tray, and storing pliofilm in open-front trays equipped with spring-loaded needles.
4. Storing film trays in positions that minimize the distance that operators must reach for each sheet.
5. Using the diagonal wrap.
6. Using the hand iron and holding the iron in one hand while the folds are being made.
7. Using methods involving more seals on large packages and fewer seals on small packages.

PACKAGING EQUIPMENT AND WORKPLACE ARRANGEMENT

Principles

A good arrangement of the work area is a great help to any operation. The area around the wrapping stations should not be congested, and when a product is disposed of after one operation it should be placed where it is readily available for the next operation. An interruption in the middle of an operation greatly reduces production. Where possible, an operator should complete one operation before moving to another. With some jobs, such as boarding and wrapping, two or more operations can be combined to save handling time. The following principles should be observed in setting up a wrapping station:

1. Adequate compact working area for the operator should be provided, with all materials and product within easy reach.

2. Adequate storage facilities for film should be provided so that the films used most often are easiest to obtain; the same should be true for boards and trays if they are used at the wrapping station.

3. The table should be of proper height for alternate sitting and standing, and a chair or stool should be provided. The height of the table for the average person should be 38 inches. Adjustments may be installed to vary this working level for tall or short employees.

4. Easy access to the unwrapped meat should be provided, preferably without leaving the station; also, easy disposal of the wrapped meat to the area where it will be readily accessible for the next operation.

5. Film should be available in the approximate sizes required for the different cuts of meats without having an excess number of sizes.

6. Sheet film should be in a tray or holder close enough to the operator so that she can obtain it readily, a sheet at a time.

Wrapping Table Construction

An "easy-reach" wrapping table was designed for a conventional operation, based on the preceding principles. In designing this table, the optimum and the maximum work areas ^{5/} for the average operator were plotted and the various materials, equipment, and product rearranged inside these areas (fig. 12). (Detailed drawings are shown in fig. 30 in the Appendix.) Film sizes were placed in fold-over trays and positioned in two places below the table surface: (1) In front of the operator; and (2) to the left

^{5/} Motion and Time Study, p. 233. By Dr. Ralph M. Barnes. (John Wiley and Sons, Inc., New York, London) (1949.)

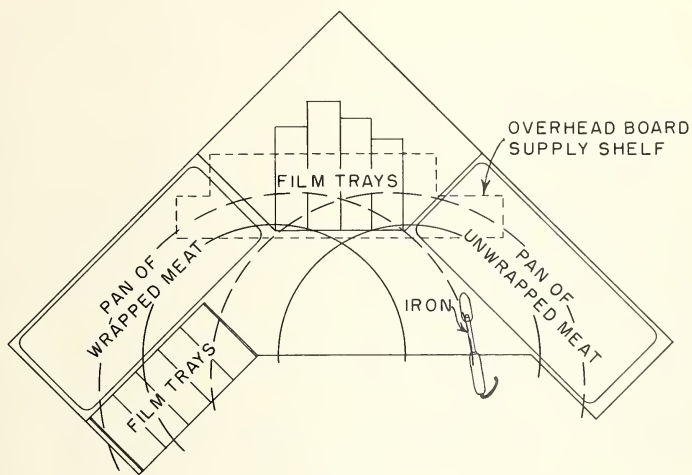

SCALE OF INCHES

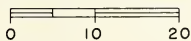

NOTE

DASHED ARCS-MAXIMUM REACH
AREA FOR RIGHT & LEFT HANDS.

SOLID ARCS-OPTIMUM REACH
AREA FOR RIGHT & LEFT HANDS.

Figure 12.--Layout of an improved meat-wrapping table, showing optimum and maximum work areas for an average worker.

of the operator. Trays were positioned on the table so that the most used sizes were closest to the operator. Meat boards and trays were placed in a rack 8 inches above the table surface and in front of the operator. Where roll film, torn from the roll, was used, a shelf for the roll was provided above the table surface to the left or right of the operator. The area for the pan of unwrapped meat was placed to the right of the operator and the area for the pan for wrapped meat was placed to the left of the operator. This arrangement was developed from a motion study of the use of the hand iron to determine how to balance the work load between hands. The operator can reach any part of any pan when it is properly placed. A stool was provided so that the operator might alternately sit or stand. The table provides space for a seal plate, although none was used with the tables tested. The easy-reach table required less floor space in the market in which it was first installed than the conventional table.

The easy-reach table was compared with two other wrapping tables that were being used. For one of these tables, the film was stored in drawers in front of the table, and for the other table the film was stored in racks above the table (fig. 13). In both cases the boards were stored under the table and were obtained in batches and placed on the table. Often excess boards had to be returned. Two groups of packaging operations were compared for these tables: (1) Obtaining the boards and film; and (2) all handling of the product except that included in the actual wrapping operation. Packaging operations on the easy-reach table proved slightly faster than did those on the other two types of wrapping tables (table 6). The convenience of the easy-reach table should cause less fatigue for the operator and thus have a favorable effect on production.

Table 6.--Comparison of the time required to package meat on two conventional wrapping tables and on the easy-reach table

Packaging operation	Filem in	Filem	Easy-reach
	drawers,	overhead,	table
	table #1	table #2	
	Man-minutes	Man-minutes	Man-minutes
Obtain film, and board when used	0.089	0.077	0.072
Miscellaneous product handling076	.076	.067
All other procedures625	.625	.625
Total packaging time790	.778	.764
Personal and fatigue allowance			
(15 percent)118	.117	.115
Standard time per package908	.895	.879
Packages per man-hour	66.1	67.0	68.3

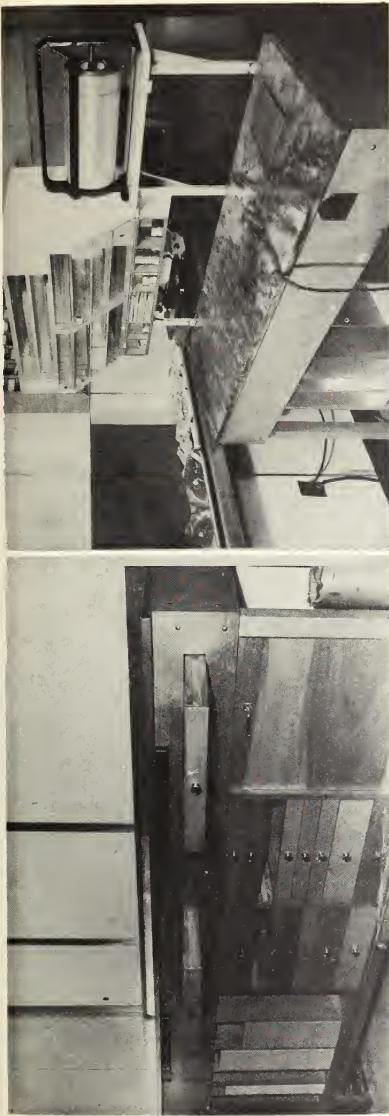

Figure 13.--Two conventional meat-wrapping tables and the easy-reach improved table.

Location of a Seal Plate in Wrapping Station

The seal plate, in the conventional wrapping station, was located at the right side of the operator 8 to 9 inches from the edge of the table. In order to determine the best location for the seal plate, studies were made of the wrapping operation with the seal plate at various locations on the table. Results indicated that the seal plate should be at the side in order to allow the space in front of the operator to be used for the wrapping of the meat. The best result was obtained with the seal plate turned at a 45° angle to the edge of the table and located with the corner of the seal plate about 8 inches from the edge of the table (fig. 14).

- CONVENTIONAL LOCATION -

TIME PER PACKAGE
IN MINUTES

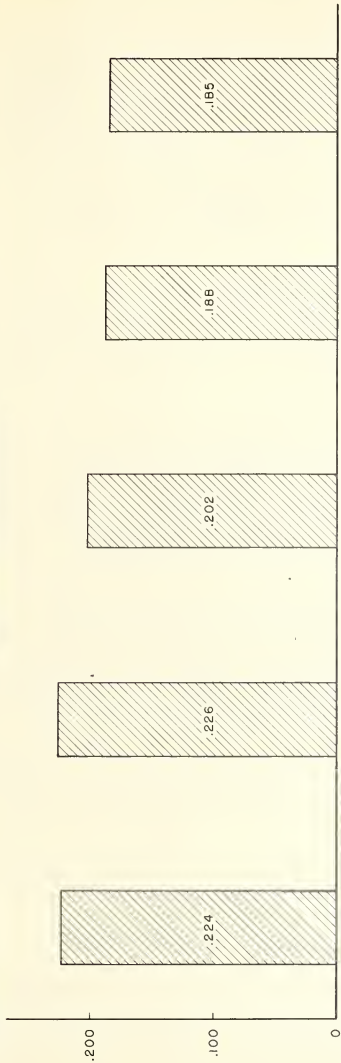

SEAL PLATE DIRECTLY IN FRONT OF WORKER - 16" FROM EDGE OF TABLE.

SEAL PLATE DIRECTLY IN FRONT OF WORKER - 12" FROM EDGE OF TABLE.

SEAL PLATE AT RIGHT SIDE OF WORKER - 8" FROM EDGE OF TABLE.

SEAL PLATE AT RIGHT SIDE OF WORKER - SET DIAGONALLY AT EDGE OF TABLE.

SEAL PLATE AT RIGHT SIDE OF WORKER - SET DIAGONALLY 8" FROM EDGE OF TABLE.

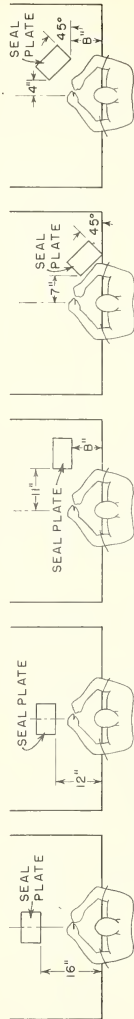

WORKER OBTAINED FILM FROM DIRECTLY IN FRONT OF WORKPLACE, OBTAINED UNWRAPPED MEAT FROM LEFT & DISPOSED OF WRAPPED PACKAGES TO PAN AT RIGHT-THE DIAGONAL WRAP WAS USED.

Figure 14.--Man-minutes per package required for wrapping meats when the seal plate was placed at different locations.

PACKAGING FILMS

The two major types of film used in meat markets as prepackaging materials are pliofilm (stretchable) and cellophane (nonstretchable). According to several manufacturers these represent about 98 percent of all films used in packaging retail meat. The other films were used on special types and cuts of meat and were not studied. Although several manufacturers make cellophane, no attempt was made to compare the films from different manufacturers. The film was used according to the manufacturers' specifications. On fresh red meats a special film with a coated side and an uncoated side was used. One sheet of pliofilm--EM-1-80-gage--was used for all meats.

Proper Handling and Storage

This study indicated that proper handling of film stocks in retail stores would prevent much loss or deterioration of the film. The following information will help to prevent such losses in handling and storing film: 6/

1. Each film has a proper temperature range under which it should be stored. Storage under too hot or too cold conditions is detrimental to film. Heat can cause blocking or sealing of the film to itself. Cold can cause brittleness and cracking of the film, depending on the type of film used. Recommended storage temperatures should be ascertained from the manufacturers and their recommendations should be followed.
2. Films are manufactured and usually delivered with the proper amount of moisture in them. Too much moisture can cause the film to wrinkle, curl, and become limp; too little moisture can cause the film to dry out and crack. It is well to check with the manufacturers on the proper humidity requirements for stored film and to keep the film stored in about that humidity. Film should be kept off damp floors and away from wet places.
3. Film (sheet or roll) should be kept in original containers until needed, as the wrappings and containers used by manufacturers are made to protect the film as much as possible.
4. Large stocks of film should not be kept, since film can age and lose some of the qualities of freshness (transparency, flexibility).

6/ Sources: (1) "Let's Check a Dozen Ways to Make Dupont Cellophane Work Better." By Film Department, E. I. Dupont de Nemours and Company, Wilmington, Del.; (2) "How to Minimize Packaging Shortage in Self-Service Meats." By Ezra Lapidès, Pre-Pak Consultant, Willer & Miller, Inc.; (3) "Packaging Manual for Self-Service Meats," p. 61, Pliofilm Dept., Films & Flooring Division, the Goodyear Tire & Rubber Company, Inc., Akron, Ohio. In mentioning firms and products no recommendations or discrimination is intended.

5. Care should be taken to avoid dropping or mishandling films. Nicked edges cause tearing and binding during the handling of film. Operators often cut film to smaller sizes on meat power saws. One of the dangers of this operation is that the sawed edge of the film may be rough and thus provide nicks where tears can easily develop. To avoid tearing, the operator must use considerable care in wrapping. Sometimes an operator allows a pack of film to rest too near a hot seal plate or iron, which causes the entire pack of film to seal together.

6. It is best to keep roll film on horizontal racks to prevent telescoping of the film during handling. The constant side pull caused by tearing the film will telescope it until it will bind on the end of the stand unless the ends of the rolls are protected by some type of disk or crosspiece. It is very difficult to return a telescoped roll to its original shape.

Yield

When roll stock film is used a certain degree of skill is required to tear off the film from the roll so that it will fit the product. Film yield varies according to the ability of the operator to tear off sheets of the correct size. Film torn too short for a particular package is often lost before it can be used. In one test, skilled operators were handed a package of meat and asked to tear off 10 sheets of film to fit the package. Considerable variation was found in the lengths of film. For 10 sheets of film, there was as much as 4 inches difference between longest and shortest (Appendix table 24).

A factor that affects film yield is the ability of meat wrappers to select the correct film sizes to use. Tests were made with five operators in two markets to determine the sizes, in square inches, of film used to wrap different cuts of meat when the operators tore sheets of pliofilm from the roll, and when the operators selected sheets of pliofilm or cellophane from a supply containing four sizes of pliofilm and six sizes of cellophane. The results of these tests indicated that there are no significant differences in square inches of film per average package.

In order to determine the effect of the size of product wrapped, a statistical curve was developed from records maintained on film usage for a number of different cuts of meat. This statistical curve indicated that the film cost per pound of meat wrapped for small packages is much higher than that for large packages (fig. 15).

The yield of films, and the productivity of workers using them, was studied in four markets for 2-week test periods. Detailed records were kept on the number of pounds of meat, and square inches of film used, and the number and weight of the packages wrapped during the test periods. Each film was used exclusively for the 2 weeks in which it was being tested. Sheet cellophane was tested in all four stores, roll cellophane was sheeted in one of the stores, roll pliofilm was sheeted in three stores, and roll pliofilm was used from the roll in two stores.

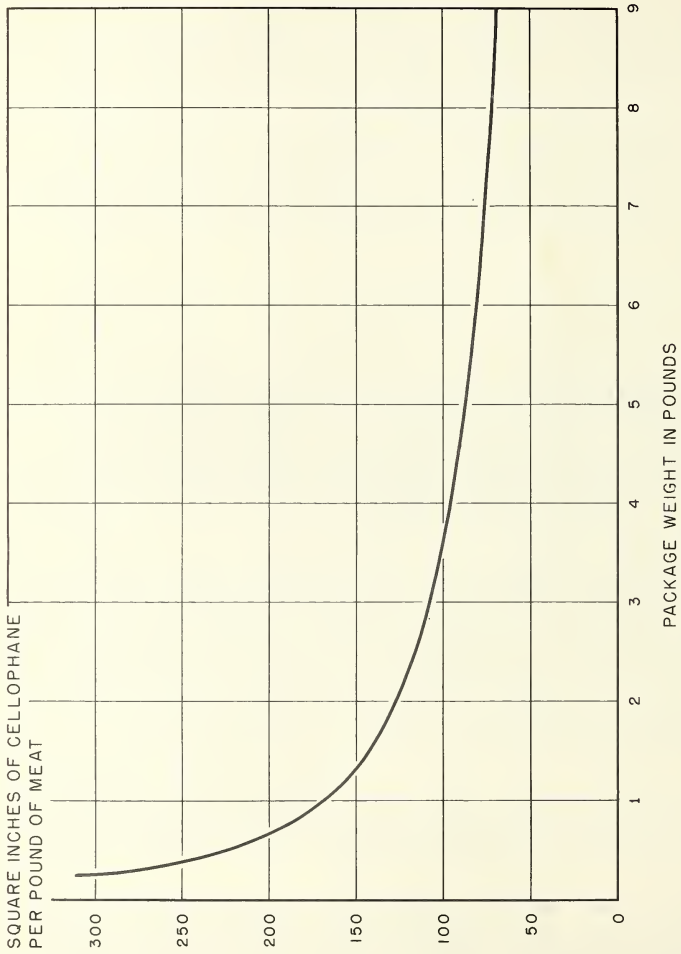

Figure 15.--Relationship between weights of meat packages and amounts of cellophane required in square inches per pound of meat wrapped in four self-service stores.

There were no significant differences in yields between sheet cellophane and roll cellophane sheeted in the store, or between roll pliofilm sheeted in the store and roll pliofilm used from the roll. ^{7/} In all stores the number of pounds of meat per pound of pliofilm was considerably higher than the number of pounds of meat per pound of cellophane. The greater part, and perhaps all, of this difference was due to the larger number of square inches per pound of pliofilm used. ^{8/}

Labor Productivity

The labor productivity resulting from the use of the two types of films was obtained by detailed time studies for at least 50 percent of the items in the entire packaging operation. A large number of studies were made of the same skilled personnel using the two types of films in each store. In addition to the films listed above, sheeted pliofilm also was included in the productivity studies. In the case of roll films, the labor required in sheeting the film was included as part of the film cost. The operators had worked with both types of films before the studies were made, and they used seal plates on pliofilm and hand irons on cellophane. These studies indicated that there was a higher labor productivity when cellophane was used for wrapping in any given store (table 7). Minor differences in labor productivity were found between meat-packing operations in which sheet cellophane and roll cellophane sheeted in the store were used, and between operations in which roll pliofilm sheeted in the store and roll pliofilm in the roll were used.

Table 7.--Comparative labor productivity for meat-packaging operations from using different forms of cellophane and pliofilm in three self-service food stores

Store No.	Packages per man-hour when using--				
	Sheet cellophane	Roll cellophane sheeted	Sheet pliofilm 1/	Roll pliofilm sheeted	Roll pliofilm used from the roll
	Number	Number	Number	Number	Number
1	114.9	-	85.6	111.7	-
2	96.3	94.0	-	84.8	-
3	73.3	-	-	69.4	67.7

^{1/} With slip sheets between each sheet, tested for labor productivity only.

^{7/} Roll cellophane used from the roll was not tested because of the tendency of this film to tear badly.

^{8/} During the study, measurements were made on film yields. Square inches per pound for coated, 300-gage cellophane, were 19,649, and for uncoated, 300-gage cellophane, 20,572. Square inches per pound for roll pliofilm, 90-gage, 29,337, with considerable variation within the rolls. (See Appendix table 25.)

Reject Packages

Detailed records were kept of the packages removed from display for all of the 2-week periods in four stores. From 2-1/2 to 8-1/2 percent of the packages were rejects and were removed from the displays for either reconditioning or disposal. In each store there was a higher percentage of torn and leaky packages for the cellophane-wrapped meat than for pliofilm-wrapped meat. In three of the four stores a higher percentage of discoloration occurred in the pliofilm-wrapped meat than in the cellophane-wrapped meat. Different store policies appeared to cause greater variation in the number of packages removed from display than did the difference between the two types of films (table 8).

Table 8.--Percentages of meat packages removed from display for specified reasons in four self-service meat departments, in 2-week periods

Type of package and store :	Reason for removal :			Total
	Torn or leaky :	Discoloration :	Outdated :	
	Percent	Percent	Percent	Percent
<u>Cellophane-wrapped package:</u>				
Store No. 1	1.00	2.11	0	3.11
No. 248	2.26	0	1/ 2.74
No. 323	.19	4.53	4.95
No. 424	.10	8.10	8.44
<u>Plioilm-wrapped package:</u>				
Store No. 117	3.23	0	3.40
No. 236	2.10	0	2/ 2.46
No. 300	.66	3.43	4.09
No. 403	.18	8.39	8.60

1/ Four weeks.
2/ One week only.

The number of packages removed from the case in store No. 3 and store No. 4 because they had exceeded their shelf life or because the item had been overstocked, far exceeded the torn or discolored packages. Although one store did not require that the packages be taken from the case after a definite period, the market managers often brought packages back for rewrapping and reconditioning in order to enhance their sales appeal.

The most important single factor governing the number of packages removed from the case was the ability of the market manager to foresee the customer demand for different items.

Film Cost Comparisons

Comparison of Sheet and Roll Cellophane

A cost comparison was made of sheet and roll cellophane sheeted in the market during a 2-week test period. The type of film sheeter used in this study is shown in figure 16. The study indicated that there is a net saving of about \$150 per year when roll cellophane sheeted in the store is used in a market utilizing an average of 5,000 sheets of film per week (table 9). The saving was based on a cost of \$0.038 per 1,000 square inches for sheeted film and \$0.63 per pound for roll cellophane yielding 19,500 square inches per pound. The additional roll stock inventory shown in table 9 is needed because of the size of the rolls that were stocked in place of sheets.

Table 9.--Comparative costs of using 300 gage roll and sheet cellophane in one self-service meat department 1/

Cost item	Cost basis	Annual cost
		Dollars : Dollars
Cost of sheet cellophane:		
Total	\$0.038 per 1,000 square inch	1,669.72
Cost of roll cellophane:	\$0.63 per pound @ 19,500 square inch is \$0.0323 per 1,000 square inch	1,419.26
Sheeting cost in store	\$0.338 per 1,000 sheets	87.88
Cost of sheeter	\$50 depreciated in 10 years	5.00
Cost of additional film inventory roll cellophane	\$54 per year @ 5 per cent	2.70
Total roll cellophane cost per year		<u>1,514.84</u>
Savings per year in using roll cellophane sheeted in store		154.88

1/ Based on using an average of 5,000, 13" x 13", sheets per week.

Cost Comparison of Pliofilm and Cellophane

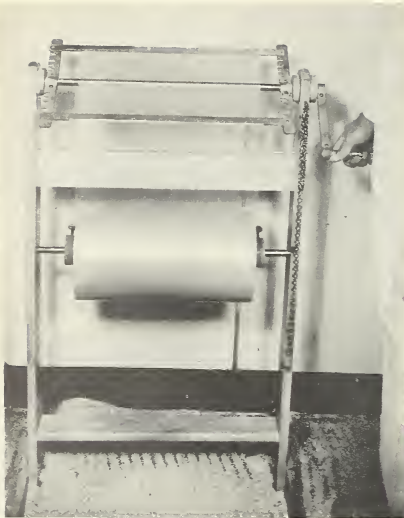

Figure 16.--One type of film sheeter used to sheet roll film.

During the 2-week period that cellophane and pliofilm were being tested in four stores, the cost of the film per 100 pounds of meat sold favored cellophane in all stores. During the study the film cost was as follows: Roll pliofilm \$1.27 per pound; roll cellophane \$0.63 per pound; sheet cellophane (300 gage) \$0.038 per 1,000 square inches; sheet cellophane (450 gage) \$0.055 per 1,000 square inches. The freight cost was not included. With roll stock film, the sheeting cost was added to the cost per pound of the film. These prices were subject to change and applied only at the time of the study. Since average package weight has considerable effect on film yields, the effect of the size of the package on yield of the film was eliminated by adjusting the film cost to an average package weight.

The cost per package wrapped with roll cellophane sheeted in the store was less than with sheet cellophane. The cost of roll pliofilm sheeted in the store was slightly more than for roll pliofilm used from the roll. In all stores the cellophane cost per package was less than for pliofilm (table 10). The total per package costs of film, boards or trays, and packaging labor indicated a twofold advantage for cellophane, for example, lower costs for both film and labor (fig. 17).

In addition to cost differences, the differences in the physical properties of the two types of film affect their relative usefulness for wrapping meat. The physical properties of the films were not evaluated in this study.

A comparison of the cost of direct labor and materials when cellophane and pliofilm were used was made on the basis of these 2-week test periods in three stores using the most common packaging methods. Figure 18, based on these results, shows the prices at which the packaging costs of the two films would have been equal. The diagonal lines indicate that equal packaging costs are based on the actual amounts of film used and account for the labor productivity advantage of cellophane and the cost of sheeting pliofilm. An operator must assume operating conditions and labor productivity

- STORE 1 -

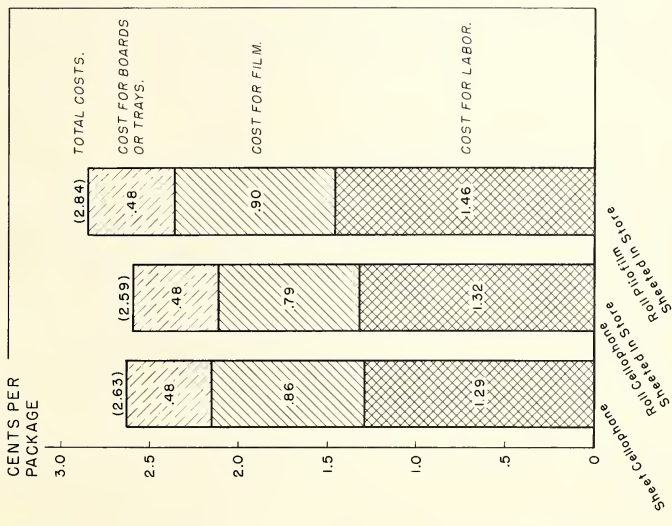

- STORE 2 -

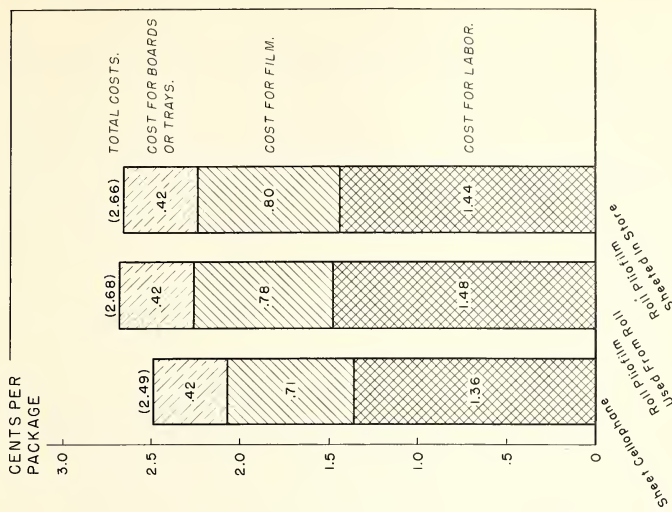

Figure 17.--The price of film, board or tray, and repackaging labor per package using cellophane and pliofilm in two stores in a southeastern city.

similar to those in the test stores in order to use this chart (fig. 18) correctly.

Table 10.--Comparative costs of film per package of meat sold in four self-service markets for 2-week test periods, adjusted to average package weights

Store No.	Average package weight	Cost of--			
		Cellophane sheets	Roll cellophane sheeted in store	Roll pliofilm sheeted in store	Roll pliofilm used from roll
	Pounds	Cents	Cents	Cents	Cents
1	1.215	0.842	-	1.096	-
2	1.215	.864	0.789	.900	-
3	1.282	.708	-	.805	0.781
4	1.282	.741	-	-	.765

To use the chart an operator should determine the delivered cost of the two films. After the cost of pliofilm has been located on the base line of the chart, a line should be extended from that point parallel to the existing line for pliofilm shown on the chart. In like manner, a similar line should be drawn for the cost of cellophane. Find where these two cost lines intersect on the chart. The location of that point in relation to the equal packaging cost lines will determine which film has the lowest cost. These equal packaging cost lines are given for average wage rates of \$.90, \$1, and \$1.10 an hour for packaging labor. The costs at the time of this study, excluding freight, of \$.038 per 1,000 square inches of cellophane and \$1.27 per pound for pliofilm favored the use of sheet cellophane.

Selection of Proper Size Wrapping Materials

Sizes for film, boards, and trays for prepackaging meats should be selected on the basis of the weight, dimensions, and quantity of the different cuts of meat to be wrapped, and the cost of the film used should be compared with the cost of the wrapping labor. The following rules are suggested for selecting the proper sizes of boards, trays, and film:

1. The proper size film for each cut should be determined by the overlap rule. As previously stated, the lowest cost per package was obtained when the average size package was wrapped diagonally with a 1-inch overlap of film measured at right angles to the edge of film (fig. 19).

2. Slightly rectangular sheets of film should be used. Tests indicated that slightly rectangular pieces of film wrapped larger packages than did a square piece of film of the same number of square inches.

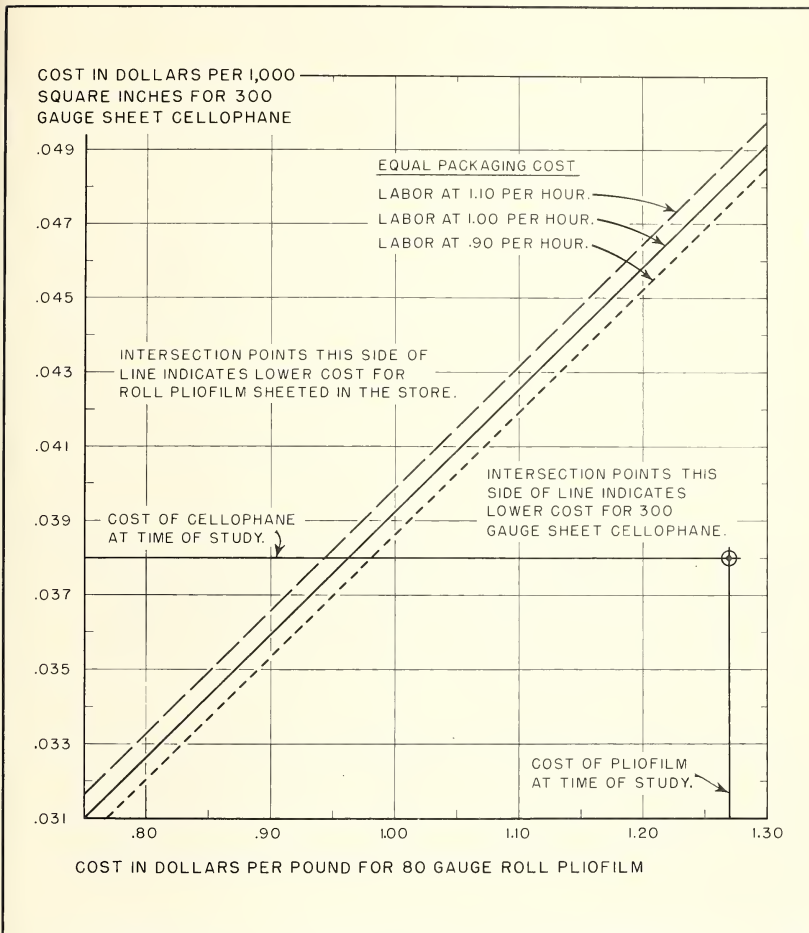

Figure 18.--Comparative packaging costs using 300-gage sheet cellophane and 80-gage roll pliofilm sheeted in the store.

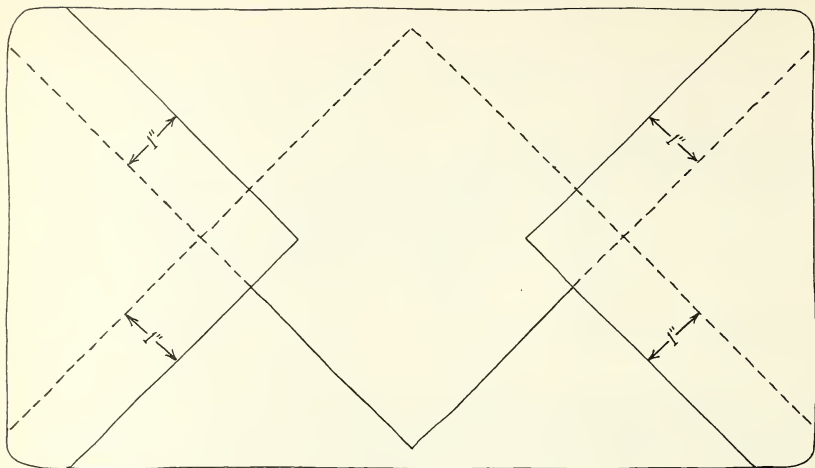

Figure 19.--Showing how to measure the 1-inch overlap in determining optimum size sheet of film.

The reason for this was that most meat packages are oblong and the employee, when coming to a package that was large for the size of film, would turn the package beyond a diagonal position to wrap it. For example, a 5" x 6" piece of film, which totaled 30 square inches, wrapped a box 5/8-inch thick by 2 inches by 4 inches with twice as much film overlap as a piece of film 5-1/2" by 5-1/2" which totaled 30.25 square inches (fig. 20).

3. The number of sizes of film stocked should be kept at a minimum. It was found that the larger sizes of films were so seldom used, and were so expensive to stock, that the operator could save money by wrapping these few packages with two pieces of smaller size film even though this took longer. If the correct sizes of film were provided for every package wrapped in the market, a large number of film sizes would be necessary. The film sizes should be selected to provide the largest number of packages with the optimum film sizes and still provide film sizes to wrap all large-volume items.

4. The smallest possible board or tray size should be used. When the board or tray overlaps the meat, a larger size of film is frequently required, thus increasing film cost as well as the cost for the larger board or tray.

FILM SIZE $5\frac{1}{2}'' \times 5\frac{1}{2}''$

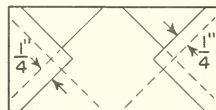
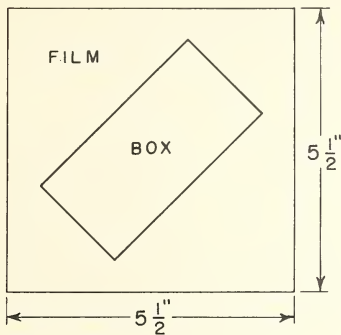

FILM SIZE $5'' \times 6''$

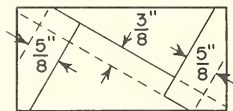
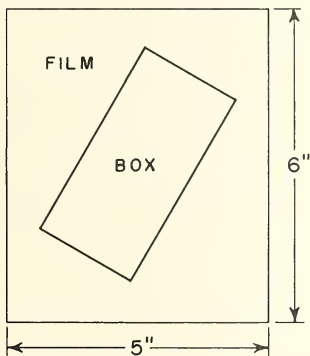

Figure 20.--Wrapping a box $5\frac{5}{8}'' \times 2'' \times 4''$ in film of two sizes: One piece $5\frac{1}{2}''$ by $5\frac{1}{2}''$; and the other piece $5'' \times 6''$.

These rules were applied to two test stores and the suggested board, tray, and film sizes for most cuts of meat were provided. (See Appendix tables 26 and 27.) It is important to keep in mind that these were only guides and that the operators were instructed to vary the film sizes to fit the unusual sizes of packages within a given lot of meat.

Because of the differences in meat-cutting practices, the volume of different cuts sold, and the average weights of packages, these sizes would not apply in all stores. The sizes are given as an example of applying the 1-inch overlap rule to average cuts of meat in two stores and adjusting these sizes in order to get maximum production with the minimum number of sizes of film required for all packages wrapped.

The two test markets were converted to accommodate the recommended sizes of film, board, and tray sizes, and studies were made of the results. Although the operators did not in all cases use the recommended sizes, a comparison based on what the markets used when provided with the new sizes of films and what they used when provided with the old sizes, resulted in a saving of 8 percent in board and tray costs and a 19.4 percent saving in film. In addition, time studies indicated that there was a slight increase in packaging production per man-hour. The reason for this increase was that some of the old film sizes were too large and the productivity was slightly faster when a smaller film was used.

PRICING METHODS AND COSTS

Pricing Meats Packaged in the Store

In the stores studied, about two-thirds of the meat packages priced were packaged in the store. All meat items packaged in the store required weighing and pricing. In one store, the inside labeling system was used and the label was placed on the package as it was weighed. These packages were weighed after the product had been boarded or trayed and before it was wrapped. In another store, the outside labeling method was used and labels were applied to the package after the package was wrapped and before it was weighed. In this case the labels were conventional thermoplastic-coated heat seal labels applied with a hand iron. In still another store where the outside labeling method was used the labels--called delayed action labels--were applied as the package was wrapped. These labels had a thermoplastic coating which activated slower when heat was applied, but remained sticky for a few seconds after being heated.

Where inside labels were used, the operator usually wrote the weight and price on the label while the package was on the scale. This operation was usually performed on the table beside the scale. Where outside labels had already been attached to the wrapped package, the operator usually read the price and weight from the scale, picked up the package and wrote the weight and price on the label. In several markets the scale was recessed into the scale table and a small area was provided in front of the scale on which the package rested when the operator priced it.

The date coding of labels was usually done by punching a hole through the number of labels required for the product being processed. In one store this was done by the meat cutters, in another store by the wrappers, and in the store which used the inside labels it was done by the scaler. A few operators wrote the price per pound on all labels before weighing the packages. In one store where this procedure was studied, it was found that writing the price per pound as a separate operation required 36 percent more time per package than when this function was performed at the time the package was weighed and priced. This difference in time was caused by the additional handling required for each label when the separate operation was performed.

A comparison of the time taken to package and price the inside label and the outside label with conventional thermoplastic coating proved that the inside label method is slightly faster (table 11), because of the need for heat sealing the outside label to the package. The inside labeling method has two disadvantages: (1) The label tends to get greasy and soiled in the package; and (2) when a package must be repriced it is necessary to rowrap the package. Some operators believe that inside labels reduce losses from customers switching labels; however, a good thermoplastic coated label properly sealed on the package cannot be removed without damaging the label beyond recognition.

Table 11.--Comparison of the time required to package and price selected cuts of meat, using inside and outside labels ^{1/}

Meat item	Time required for inside label			Time required for outside label			Time saved by using inside labels
	Package	Price	Total	Package	Price	Total	
	Man-minutes	Man-minutes	Man-minutes	Man-minutes	Man-minutes	Man-minutes	Percent
Sliced luncheon meat	0.145	0.144	0.289	0.187	0.121	0.308	6.6
Sliced bologna169	.150	.319	.207	.121	.328	2.8
Ground beef and stew beef.154	.144	.298	.208	.101	.309	3.7
Chuck roast,288	.174	.462	.349	.141	.490	6.1
Salt meat.144	.138	.282	.163	.137	.300	6.4

^{1/} These time requirements are for the regular elements only. Included in the packaging times are these operations: Getting and positioning film, wrapping the meat, sealing and disposing of the package. Times shown for pricing include weigh, price, and dispose elements only.

Pricing Meats Delivered Packaged

In the stores studied, the ratio of packages of meat packaged in the store to those prepackaged when received was about 2 to 1. Items received at the store prepackaged consisted of two types: (1) "Catch weight" packages, consisting primarily of prepackaged luncheon meat which had to be weighed and priced, represented 12.9 percent of the total packages processed in one store; (2) "even weight" packages, such as 1-pound packages of sliced bacon, weiners, and franks, which had to be priced only, represented 20.2 percent of the total packages processed in the same store.

Catch weight packages were handled in the same manner as those containing meat packaged in the store. Even weight packages were handled in some stores by applying previously marked conventional thermoplastic labels. The label-printing machine, which is discussed later in this report, was also used for this operation. Some operators used 1/2-inch by 1-inch gum labels. These labels required no heat.

The most rapid operation was to put the price directly on the package with self-inking stamps (fig. 21). Wax pencils and adjustable stamps were sometimes used for this function, but both of these methods were slower than the self-inking stamps. When adjustable or self-inking stamps were used, it was necessary to use a quick-drying ink to prevent smearing of the price. The manufacturer of the self-inking stamp developed a quick-drying red ink that proved satisfactory for this purpose. One market which had been using the small gum labels without printing was equipped with the self-inking stamps and production increased almost threefold with this pricing method (table 12).

Table 12.--Comparative production per man-hour for pricing specified types of meat in even weight packages, using white gum labels, and self-inking stamp set

Pricing method	Production per man-hour for--	
	Type of meat package	
	Franks and sausage	Bacon
	Number	Number
White gum label	416	300
Self-inking stamp set	930	1,080

Comparison of the Direct Store
Handling Costs for Meat Packaged
in the Store and Meats
Received Packaged

The direct labor and materials costs of handling luncheon meat items that were previously packaged and those packaged in the store were compared in one store. As shown in table 13, these handling costs per package for selected luncheon meat items packaged in the store were 1.723 cents compared with 0.441 cent for items purchased in pre-packaged form.

In addition, the percentage shrink in handling and packaging items in the store was studied in one store for the three largest-volume luncheon meat items (bologna, spiced luncheon meat, baked ham), and the wholesale and retail prices per pound were compared for both methods of handling. Results indicated that the gross margin for the



Figure 21.--The self-inking stamp in use
for pricing meat packages.

three selected luncheon meat items did not reflect accurately the difference in the store's costs of handling (table 14).

Table 13.--Comparative time requirements and costs for direct labor and materials in one store for handling selected luncheon meat items packaged in the store and those purchased packaged 1/

Cost item	Time requirement for--					
	Item packaged in the store			Item purchased packaged		
	Time per package	Time per package	Time per package	Time per package	Time per package	Time per package
	: Man-minutes	: Cents	: Man-minutes	: Cents	: Man-minutes	: Cents
Receiving . . .	0.026	0.065	0.059	0.148	0.026	0.065
Cutting224	.560	.509	1.273	-	-
Packaging and pricing380	.635	.864	1.443	.161	.269
Display064	.107	.145	.242	.064	.107
Subtotal :						
cost694	1.367	1.577	3.106	.251	.441
Materials cost:	-	.356	-	.809	-	.000
Grand total cost :	-	1.723	-	3.915	-	.441

1/ Average package weights 0.44 pound.

Table 14.--Comparative direct costs and returns per pound in one store for handling three luncheon meat items packaged in the store and those purchased packaged ^{1/}

Cost and profit item	Item packaged in store			Item purchased packaged		
	Bologna	Spiced luncheon meat	Boiled ham	Bologna	Spiced luncheon meat	Boiled ham
	Dollars	Dollars	Dollars	Dollars	Dollars	Dollars
Cost price	0.42	0.425	0.90	0.53	0.63	1.07
Selling price	.69	.69	1.19	.65	.79	1.39
Gross margin	.17	.265	.29	.12	.16	.32
Labor cost ^{2/}	.0311	.0311	.0311	.01	.01	.01
Material cost ^{3/}	.0081	.0081	.0081	-	-	-
Shrinkage cost ^{4/}	.0052	.0108	.0572	-	-	-
Margin over direct cost	.1256	.2150	.1936	.11	.15	.31
Percentage margin over cost price	29.9	50.6	21.5	20.8	23.8	29.0

^{1/} Labor and material costs represent about three-fourths of all the costs to the store. The other costs not listed would remain the same for both methods of handling.

^{2/} The labor cost for both methods of handling represents about 85 percent of the labor in the meat market. The other labor would be the same for both methods of handling.

^{3/} This material cost represented 100 percent of the material costs for luncheon meat.

^{4/} The shrinkage cost is calculated as a percentage of sales prices because it represents a loss in the quantity that can be sold.

PRICING EQUIPMENT AND WORK PLACE ARRANGEMENT

Scales

Detailed observations were made on four standard-type self-service meat scales. Scales A, B, and D were special scales for prepackaging with prisms over a drum to show the price. Scale C projected the price per package and the weight from a small glass plate through a series of mirrors to reflect on a frosted glass plate on the front (fig. 22). On this scale the price, as well as the weight, was always in the same spot on the face of the scale.

Productivity and Accuracy

In several stores, operators were trained in the operation of each of the scales and then time-studied for productivity. In addition, packages were check-weighed for accuracy. Two errors were possible on each package, an error in weight and an error in price. In the check readings, the methods used were the same as those used by the operators. In most instances, this involved recording to the nearest quarter-ounce in weight and to the nearest cent in price. Most errors found were quarter-ounce and one-cent errors. Scale C had the lowest percentage of error and the highest production of the four scales tested (table 15). Both of these advantages can be traced to the better readability and faster balancing of scale C. Accuracy tests were confirmed by check studies in various parts of the country.

Table 15.--Operator productivity and relative accuracy in weighing and pricing operations with four prepackaging scales

Scale	Packages weighed per man-hour	Percentage of possible error
	1/ Number	2/ Percent
A	355	31.8
B	339	30.4
C	366	19.5
D	353	44.0

1/ For regular weighing and pricing elements only, using outside labels attached to package.

2/ Two possible errors for each package: Weight and price. For example, on Scale A, 31.8 errors were found out of a possible 100 errors on each 50 packages, for an error percentage of 31.8. Most of the errors were quarter-ounce and one-cent errors.



Figure 22.--Four prepackaging scales tested for productivity, accuracy, and available prices per pound.

Number of Prices Shown on Price Charts

In order to determine the most common prices used in pricing meats throughout the United States, data were obtained from the January 1, 1952, Cost of Living Index, issued by the Bureau of Labor Statistics, U. S. Department of Labor. The sample of meat prices was taken in 7 large and 5 small cities and contained 4,590 price observations for 17 high-volume items sold in the meat departments. Data in table 16 show the number of occurrences for each of the most common prices calculated as a percentage of the total observations. (The data are shown for all prices in Appendix table 28.)

Ten prices accounted for 54.82 percent of the total observations. Twenty prices accounted for 68.58 percent, 30 for 77.00 percent, and 40 for 81.99 percent. Sixty prices, or more than one-half of the 118 prices reported, accounted for only 1.92 percent of the total observation.

Table 16.--Percentage of the total number of price observations for the 20 most common meat prices, 1951 ^{1/}

Price per pound (dollars)	Percentage of total price observations		Accumulative percentage of total price observations	
	:	Percent	:	Percent
0.69	:	9.67	:	9.67
.59	:	8.26	:	17.93
.65	:	8.13	:	26.06
.49	:	6.47	:	32.53
.79	:	5.09	:	37.62
.75	:	4.65	:	42.27
.55	:	3.60	:	45.87
.63	:	3.36	:	49.23
.39	:	2.84	:	52.07
.45	:	2.75	:	54.82
.89	:	2.73	:	57.55
.53	:	1.90	:	59.45
.85	:	1.88	:	61.33
.35	:	1.35	:	62.68
.68	:	1.11	:	63.79
.78	:	1.01	:	64.80
.47	:	.96	:	65.76
.43	:	.96	:	66.72
.57	:	.94	:	67.66
1.10	:	.92	:	68.58

^{1/} A complete list of these prices is given in Appendix table 28.

The last digit in the price (9 in \$1.29 for instance), was a considerable factor in the price. Nines and fives were the last digits in 63.80 percent of the prices. Sixes, ones, and fours were the least common (table 17).

The price charts of the four scales tested for speed and for accuracy had a fairly high percentage of the prices found to be most common. Scale A had 85 prices per pound which represented 91.09 percent of the price observations. Scale B had 67 prices per pound representing 89.90 percent of the price observations. For scale C two different price plates were checked. The first and earliest plate had 103 prices that represent 94.42 percent, whereas the new price plate brought out during the study had 124 prices representing 99.05 percent of the price observations. Scale D had 56 prices and these represented 75.95 percent of the price observations. (See Appendix table 29 for price charts of each scale tested.)

Table 17.--Percentages of total prices observed with specified last digit numbers in prices

Last digit of price	Percentage of total price	Accumulative percentage of total Percent
9	39.24	39.24
5	24.56	63.80
3	9.08	72.88
0	6.74	79.62
8	5.28	84.90
7	4.39	89.29
2	3.26	92.55
4	2.92	95.47
1	2.43	97.90
6	2.10	100.00

During the study a combination scale and label printer was developed by one company. This printing machine had 105 prices representing 96.79 percent of the price observations. The machine is discussed further in a later section of this report.

Tare Adjustment

In weighing meat packages it is necessary to adjust the scale to account for the weight of the packaging materials. A small device was perfected by the researchers to eliminate the necessity for weighing the packaging materials to make the tare adjustment (fig. 23). This device consisted of a pointer attached to the tare knob on the scale. A white card was inserted in a frame to the rear of the pointer and colored or numbered lines were drawn on the card to indicate the weight of the various tares required in a given market. 9/ Samples of the actual tares were

9/ See fig. 31 in the Appendix for detailed drawing.

placed above the scale and colored or numbered to match the corresponding color or number on the indicator card. The operator needed only to turn the indicator to the proper line for each tare set. Once the color or number code was learned by the operators, the actual tares were discarded. There was a saving in space, the appearance of the scale table was neater, and there was a saving of time at the scale when the tare indicator was used. The conventional method of taring the scale required 0.093 man-minute per tare set. With the tare indicator, this operation took 0.032 man-minute. Several months of experimentation indicated that increased accuracy resulted with the tare attachment because: (1) It was easier to set the tare accurately with the tare set; (2) there was less tendency on the part of the operator to forget to set the tare; and (3) sample boards or trays used to set the tare, and that tend to increase in weight through continued long use, are eliminated.

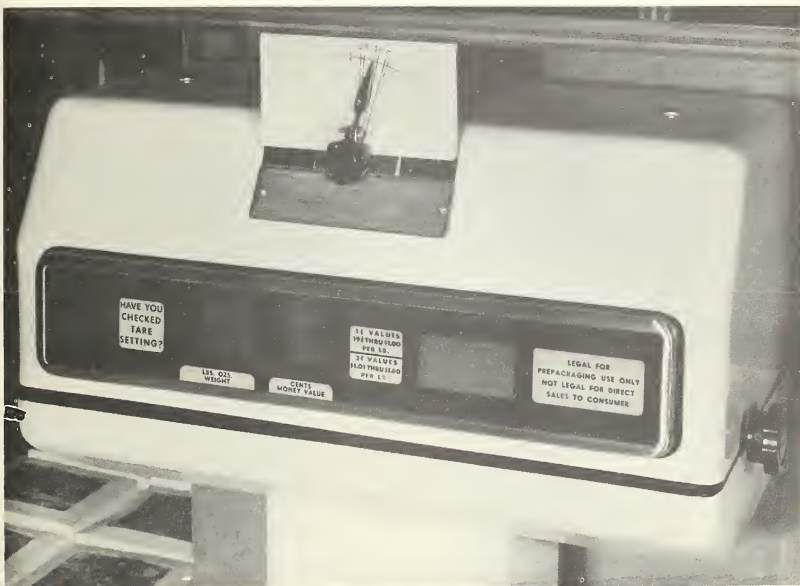

Figure 23.--Tare indicator attachment installed on a prepackaging meat scale, showing numbers indicating different tare weights.

In order to gain the desired maximum accuracy in setting the tare with the tare indicator, it was necessary to equip the scale with a direct action shaft in which there was no play between the tare knob and the weight drum. Scale C, mentioned previously, is now equipped with this feature. In addition, the tare indicator and a blank card (for entering the tare lines) are available when the scale is purchased.

Labeling Machine

Comparison of Productivity and Costs

During the course of this study two types of machines for printing labels, used on packaged meat, were placed on the market. These machines were tested and evaluated. One was a cash register type of machine; it was placed beside the scale and the operator punched the weight and price of the package on the keyboard. The machine printed the label on a roll of paper, cut the label from the roll and ejected it (fig. 24). The machine had these advantages: (1) It effected considerable savings in label costs; (2) it kept a list of prices on a separate roll of tape; and (3) it kept a continuous total of the items handled. Date, price per pound, grade of meat, and commodity name were set for each type of meat by means of dials or similar devices.

The second type of machine was built into a scale (fig. 25). Preprinted labels were inserted in the machine while the package was on the scale, and the price of the package was punched on a keyboard. A manually operated activation lever was then pushed and the machine printed the price per pound, the weight of the package, and the price of the package and one code letter representing the day of the week. The second code, indicating the week of the month, was punched in the labels as in the conventional operation. The price per pound was printed on the label and was set when the price per pound was adjusted on the scale. The machine had a roll of detail paper on which was recorded the price of every package weighed; however, it had no totaling device and the total amounts handled had to be added separately. The manual operating arm was awkward to operate.

With both of the label-printing machines, the pricing operation required more time than the former methods because of the necessity of applying the labels at the pricing operation. The major saving in labor for both machines was in the packaging operation. The separate label-printing machine provided an additional saving in label costs.

The two labeling machines were tested for labor productivity. The separate label printer was given extensive tests in two markets, one using a conventional outside label for cellophane, applied with the hand iron; and the other using the delayed action label, applied with a seal plate as well as with the hand iron. The combination scale and label printer was tested in one market using delayed action labels. The time required to handle and apply labels with the separate label machine was approximately

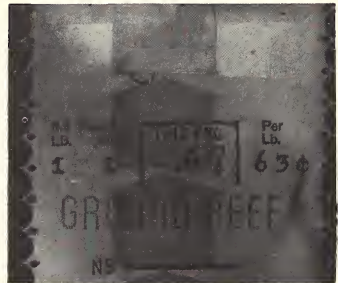
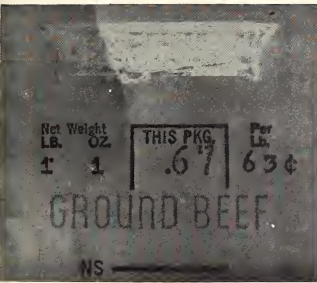

Figure 24.--Separate label-printing machine positioned on a special scale table, and several types of printed labels.

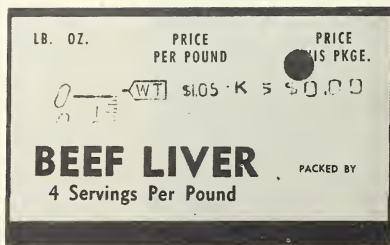
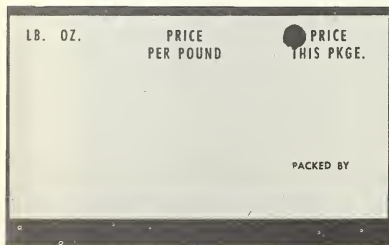
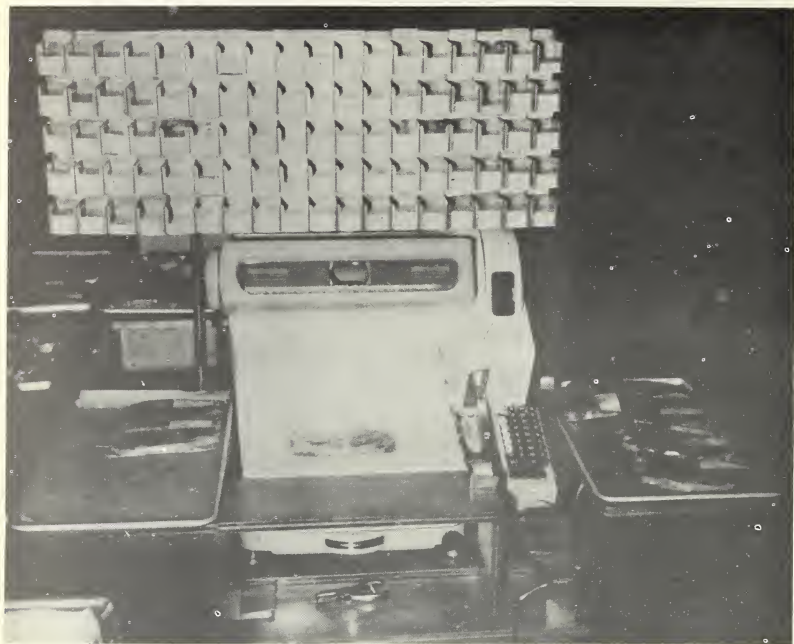

Figure 25.--Combination scale and label printer positioned on a special scale table, showing sealing iron for applying labels.

the same for both markets. When the hand iron was used to apply delayed action labels, considerable more time was required with both machines.

There was a saving in time by both machines over the conventional operation, when both pricing and packaging were considered (table 18). The combination scale and label printer required more time per package than did the separate label printer. This was due in part to the fact that a slightly longer time per package was required to weigh, price, label, and dispose of the package, mainly because of the label handling required.

The ratio of wrapping to weighing time changed materially when these labeling machines were used. These ratios relate only to items packaged and priced in the store.

The annual costs of the two label-printing machines were compared with the costs for the conventional operation (tables 19 and 20). These costs included original equipment costs, maintenance costs, pricing materials, and all packaging and pricing labor costs. The equipment was listed at single unit prices and the maintenance at the service contract costs recommended by the manufacturers.

Results of the cost comparison indicate that both label-printing machines will reduce costs for the operator when each machine handles 2,000 packages a week or more. Tables 19 and 20 show that the separate label-printing machine combined with a conventional scale gives the lowest annual cost. These tables are calculated for 2,000, 4,000, 6,000, and 8,000 packages per week per machine to indicate potential savings for different volumes of operation. Time studies indicate that on an average, a trained operator should weigh and price about 2,200 packages a day using the separate label printer, or 1,850 packages a day using the combination scale and label printer. 10/

Readability of Printed Labels

Since both machines use the printed label, tests were made to compare the ability of the personnel at the check-out counter to read these labels correctly, and their ability to read the hand-written labels. In each of two stores a number of packages with hand-written labels, and a number with printed labels, were checked out by two operators. The price marked on the package in each instance was compared with that rung up on the cash registers. The same cashiers handled the written and the printed labels. Results shown in table 21 indicate that a slight amount of error was found when the hand-written labels were used and no errors were found when the printed labels were used.

10/ Based on an 8-hour day, 0.217 standard man-minute per package equals 2,212 packages per day for separate label machine; 0.256 standard man-minute per package equals 1,875 packages per day for combination scale and label printer, less clean-up, and so forth, for both machines.

Table 18.--Comparative time required to package, weigh, and price selected meat items when two types of label machines are used with the time required when conventional packaging and pricing methods are used

Packaging, weighing, and pricing operation	Type of operation		
	Conven- tional	Separate : label : printer	Combination : scale and : label printer
	Man-minutes	Man-minutes	Man-minutes
<u>Packaging:</u>			
Obtain film and position meat ..	0.156	0.156	0.156
Wrap and seal and turn over.....	.261	-	-
Attach label and dispose package : <u>1/</u>	.090	-	-
Wrap, seal, and dispose package :	-	.261	.261
Miscellaneous, related to labels :	.024	-	-
Other packaging operations.....	.065	.065	.065
Subtotal: Packaging time.....	.596	.482	.482
<u>Weighing and Pricing:</u>			
Position package on scale, ring up, attach label, and dispose package.....	-	<u>2/</u> .149	<u>2/</u> .159
Weigh, price, and dispose.....	.143	-	-
Miscellaneous, related to labels :	-	-	.024
Miscellaneous, related to oper- ating the label machine.....	-	.018	.018
Other weighing operations.....	.022	.022	.022
Subtotal: Time per package...	.165	.189	.223
Total time per package.....	.761	.671	.705
Personal and fatigue allowance (15 percent).....	.114	.101	.106
Standard man-minute per package...	.875	.772	.811
Number of packages per man-hour...	68.6	77.7	74.0
Ratio of wrapping to weighing.....	3.61 - 1.00	2.55 - 1.00	2.16 - 1.00
<u>1/</u>	Delayed action label with hand iron.		
<u>2/</u>	Delayed action label with the seal plate.		

Table 19.--Comparative annual costs for weekly volumes of 2,000 and 4,000 packages, using conventional weighing and pricing methods, the separate label-printing machine, and the combination scale and label printer

Cost item	2,000 packages per week		4,000 packages per week	
	Conven- tional method	Separate label printer Dollars	Conven- tional method	Separate label printer Dollars
Conventional scale cost \$405 (depreciated over 12½ yr. at 8 percent)	32.40	-	32.40	-
Label machine cost \$855 (depreciated over 12½ yr. at 8 percent)	-	68.40	-	68.40
Scale and label printer cost \$1,450 (depreciated over 12½ yr. at 8 percent)	-	116.00	-	-
Commodity slugs (200 @ 90¢) \$180 (depreciated over 6½ yr.)	-	28.80	-	28.80
Label paper (3,000 labels per roll) 34.67 cents per 1,000	-	36.06	-	72.11
Detail paper (3,000 imprints per roll @ \$0.038) 1.267¢ per 1,000	-	1.32	-	2.64
Machine maintenance (free first yr. \$25 per yr. 11½ yr.)	-	23.00	-	23.00
Scale maintenance (\$4.65 per call, 6 calls a year)	27.90	27.90	27.90	27.90
Label cost \$0.97 per 1,000 (label cost 82.6¢, handling 13.6¢, and freight 0.8¢ per 1,000)	100.88	-	100.88	-
Labor cost of packaging and pricing (@ \$1 per hour)	1,516.03	1,338.48	1,405.41	3,032.07
Total annual costs	1,677.21	1,556.36	1,674.51	3,294.13
Savings over conventional method	-	120.85	2.70	-

1/ Estimate.

Table 20.--Comparative annual costs for weekly volumes of 6,000 and 8,000 packages, using conventional weighing and pricing methods, the separate label-printing machine, and the combination scale and label printer

Cost item	6,000 packages per week			8,000 packages per week		
	Conven- tional method : Dollars	Separate label printer : Dollars	Scale and label printer : Dollars	Conven- tional method : Dollars	Separate label printer : Dollars	Scale and label printer : Dollars
Conventional scale cost \$405 (depreciated over 12½ yr. at 8 percent)	32.40	32.40	-	32.40	32.40	-
Label machine cost \$855 (depreciated over 12½ yr. at 8 percent)	-	68.40	-	-	68.40	-
Scale and label printer cost \$1,450 (depreciated over 12½ yr. at 8 percent)	-	-	116.00	-	-	116.00
Commodity slugs (200 @ 90¢) \$180 (depreciated over 6½ yr.)	-	28.80	-	-	28.80	-
Label paper (3,000 labels per roll) 34.67 cents per 1,000	-	108.17	-	-	144.23	-
Detail paper (3,000 imprints per roll @ \$0.038) 1.267¢ per 1,000	-	3.95	3.95	-	5.27	5.27
Machine maintenance (free first yr. - \$25 per yr. 11½ yr.)	-	23.00	1/ 23.00	-	23.00	1/ 23.00
Scale maintenance (\$4.65 per call, 6 calls a yr.)	27.90	27.90	1/ 27.90	27.90	27.90	1/ 27.90
Label cost \$0.97 per 1,000 (label cost 82.6¢, handling 13.6¢, and freight)	302.64	-	302.64	403.52	-	403.52
Labor cost of packaging and pricing (@ \$1 per hour)	4,548.10	4,015.44	4,216.22	6,064.14	5,353.93	5,621.62
Total annual costs	4,911.04	4,308.06	4,689.71	6,527.96	5,683.93	6,197.31
Savings over conventional method	-	602.98	221.33	-	844.03	330.65

1/ Estimate.

Table 21.--Comparative readability of hand-written and printed labels at check-out counters in two self-service stores

Store (no.)	Hand-written label			Printed label		
	Checked	Errors		Checked	Errors	
	items	Number	Percent	items	Number	Percent
1....	850	1	0.12	900	0	0
2....	896	14	1.56	984	0	0

Work Place Arrangement for Weighing and Pricing

Principles

Most of the principles that apply to building a wrapping table can also be applied to building a scale table. ^{11/} The same optimum and maximum work areas must be considered. The following are some of the principles that were used to good advantage in designing and using scale tables.

1. Adequate accumulation space should be provided for use both before and after the weighing operation. The operator should not have to leave the scale after weighing each pan of product but should have facilities to accumulate several pans at a time and then dispose of them at one time.
2. If a conveyor is used, the last scale table should be built so that the operator may work directly from the pan at the end of the conveyor without having to move the pan to the scale after it rolls to the end of the conveyor.
3. All materials, such as labels and tare items, should be neatly arranged in front of and within easy reach of the operator. As many of these as possible should be eliminated by such devices as label printers and the tare indicator.
4. Codes, instructions, prices per pound of meat items, and similar items should be neatly written and posted where the operator can easily see them without moving from the scale.
5. Facilities for alternate sitting and standing should be provided for the scale operator, as well as adequate knee room under the scale table.

^{11/} See section under the heading "Wrapping Table Construction," p. 31.

6. The scale platform and the scale table should be 38 inches above the floor.

7. Enough space should be provided on a shelf in front of the scale platform to permit the operator to write on a label or package, or apply a label to the package without disturbing the scale platform.

8. If labels are applied to the package at the scale, the means of applying them should be as simple as possible.

9. When the separate label machine is used, the machine should be placed on the right-hand side of the scale for a right-handed operator. The operator should work from right to left with both label machines. When removing a package from the scale platform with one hand, the operator should replace it with another package with the other hand.

Scale Table Construction

In accordance with these principles, several scale tables were developed for the various types of equipment used. The work place shown in figure 26--an example of improved layout of the pricing operation--incorporates the best methods used with scale C and the separate label-printing machine. This arrangement is built around the optimum and maximum reach areas for both hands (fig. 26).

The proper flow of product in this workplace is from right to left. The disposal area on the left can be connected to a conveyor on which to place merchandise, or a pan storage cart can be placed under the shelf and when the cart is full it can be wheeled to the display area. (A detailed drawing for the construction of this scale table is shown in fig. 32 in the Appendix.)

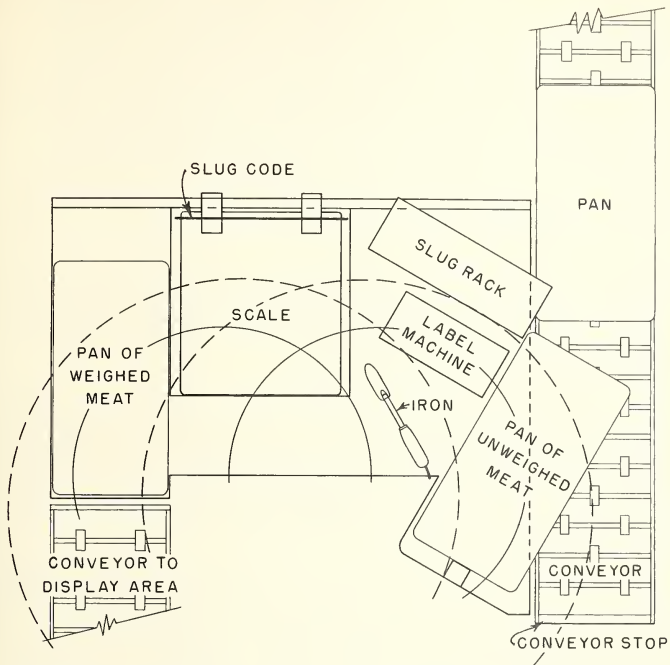

ALTERNATIVE CART
TO DISPLAY AREA
(PARK UNDER SHELF)

NOTE
DASHED ARCS-MAXIMUM GRASP
AREA FOR RIGHT & LEFT HANDS.
SOLID ARCS-NORMAL GRASP
AREA FOR RIGHT & LEFT HANDS.

SCALE OF INCHES

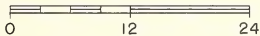

Figure 26.--Workplace arrangement developed for the separate label-printing machine and a scale showing maximum and optimum reach areas for both hands of an average operator.

SELF-SERVICE MARKET DISPLAY

Extensive studies of the display operation for self-service meats were made in two markets. These markets differed considerably in layout--one market stocked the cases from the front, the other from the rear. Both markets used a holding cooler, but one was a walk-in type located in the wrapping room, with only one door, and the other was a reach-in type with connecting doors to the wrapping room and the main store area. One market used a pass window from the wrapping area and holding cooler to the cases, and the persons stocking the display case walked around the end of the cases to get to the work area. Occasionally, a cart was used to haul merchandise to the case. The other market had a door from the wrapping room to the walkway back of the cases. The door was fairly close to the scale table and the center of the cases (fig. 27).

As shown in table 22, approximately two-thirds of the time required for display activities was in placing the product in the case or in rearranging the products after the customers had caused them to look disorderly. Most of the remaining time was spent in walking to and from the case or moving from one place to another.

The time used to display and rearrange items in the case, considered together, took about the same percentage of total display time for each of the two stores, but in store No. 1 less time was spent in arranging the original display and more was spent in rearranging the packages than in store No. 2. More time was spent on display in store No. 2 as a result of a concerted effort on the part of the personnel in the store to keep the meat cases neat and orderly.

An additional factor that may account for the greater over-all display time recorded in store No. 2 was that this store had an average package weight of 1.375 pounds compared with 1.005 pounds for store No. 1. To help determine the effect of package weight on time necessary for display activities, the time per package required for display work was plotted against average package weight. This study showed that there was a direct relationship between the time consumed in display work and the package weight.

The time required for travel and moving in both stores was about the same, but there were several significant differences in these elements between the two stores. In store No. 1 it was much farther from the wrapping areas and from the holding cooler to the display case than in store No. 2. In store No. 1, however, the personnel, by making good use of a pass window and by loading more packages per pan and handling more pans per trip when merchandise was loaded into a cart, traveled less distance per package than in store No. 2. Store No. 2 had a raised platform behind the case. In other stores where the platform was removed, walking became much easier and the use of a cart for carrying several pans per trip was made possible. Had both stores used the same method of transporting meat to the cases, the display time would have been considerably

STORE NO. 1

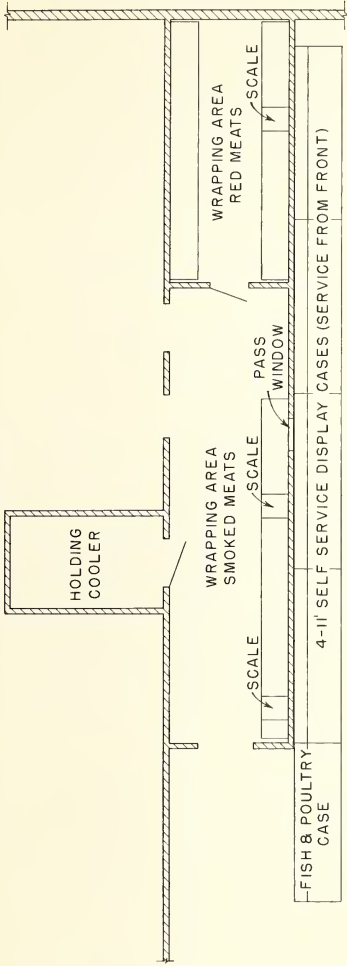

STORE NO. 2

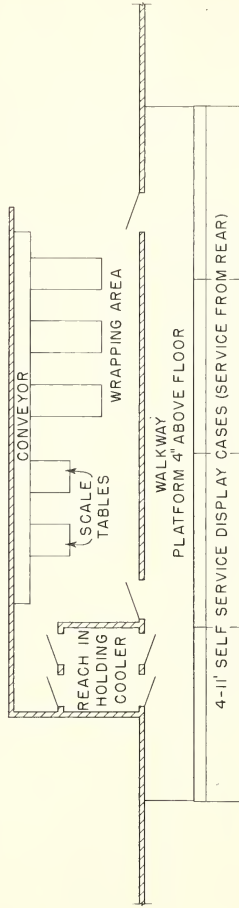

Figure 27.--Layout of display areas in two stores.

Table 22.--Relationship between time required to perform the various display functions and total display time and total direct market labor time in two self-service meat markets

Display function	Store No. 1 (cases stocked from front)			Store No. 2 (cases stocked from rear)		
	Standard time per package	Percentage of total display time	Percentage of total direct market labor time	Standard time per package	Percentage of total display time	Percentage of total direct market labor time
	Man-minutes	Percent	Percent	Man-minutes	Percent	Percent
Display in case	0.034	30.4	3.0	0.056	45.9	2.9
Rearrange in case034	30.4	3.0	.021	17.2	1.1
Travel or move037	33.0	3.3	.039	32.0	2.1
Handling and miscellaneous007	6.2	.6	.006	4.9	.3
Total112	100.0	9.9	.122	100.0	6.4

less in store No. 2, as the number of trips to the case would have been reduced.

The comparison illustrates that a considerable amount of time can be saved by proper planning of the market for display and by carrying full loads to the display case (table 23). For example, had employees of store No. 2 carried the same weight per pan as did those of store No. 1, 22.21 pounds, the time per package displayed would have been reduced from 0.122 man-minute per package to 0.093. This would have saved 25 percent of the total display time. This factor, the amount carried per pan, is of primary importance not only in display but also in the packaging and pricing and cutting operations.

Table 23.--Average weight of packages, number carried, distances traveled, and other factors in displaying meat in two self-service meat markets

Display factor	Unit	Store	Store
		No. 1	No. 2
		Number	Number
Package weight	Pound	1.0	1.4
Number of packages on a pan	Package	22.1	10.5
Weight per pan	Pound	22.2	14.4
Weight carried when walking	Pound	22.2	14.7
Weight carried to display in cart	Pound	33.3	0
Weight to display each trip to case	Pound	71.1	14.7
Pans to display each trip to case	Pan	3.2	1.0
Walking distance from scale to center of display area of case	Feet	65	15
Distance traveled per trip to case	Feet	207.4	39.5
Distance walked per pan	Feet	64.8	38.7
Distance walked per package	Feet	2.9	3.7
Number of packages displayed per door opened	Package	14.3	5.3

One difficulty encountered in displaying the merchandise in the case was that display cases provided no place to hold the pan when the merchandise was being placed in the case. As a result, the operators usually held the pan with one hand and placed the merchandise in the case with the other hand. Higher work productivity could be obtained if the manufacturers of display cases provided a 10- or 12-inch-wide holding ledge, in place of the present 4- or 5-inch ledge, at the rear of the case, thereby permitting the use of both hands in arranging the display. The use of a dolly or cart to hold several pans of merchandise proved advantageous. The merchandise was pushed to the case in the dolly and then two hands were used to place the merchandise in the case.

The following principles are set forth as guides for minimizing labor requirements in the display operation:

1. A fully loaded pan, or two or more partially loaded pans, should be carried to the display case on each display trip.
2. Wherever possible, a cart or dolly should be used to move several pan loads to the display case.
3. The floor or walkway behind cases serviced from the rear should be at the same level as the floor of the packaging area.
4. Doors connecting the packaging area and the display area should be swinging doors or should open out in the direction of the flow of product.
5. All items should have a definite location in the holding cooler, and the various sections of the holding cooler should be marked accordingly.
6. Whenever possible, both hands should be used to place the merchandise in the display case.

RESULTS OF APPLYING IMPROVED METHODS, MATERIALS,
AND EQUIPMENT IN TWO TEST STORES

In two typical stores where studies were made, selected improvements discussed in this report were applied. These stores had different layouts and operating policies, and therefore different improvements were applied in each. Personnel were trained to use the improved methods, materials, and equipment.

In store No. 1, packaging methods were changed as follows: Instead of laying the hand iron down between seals it was held between seals; the new easy-reach wrapping table was installed; the film used for wrapping was changed from roll pliofilm to roll cellophane sheeted in the store. For pricing, the separate label-printing machine, new type pricing table, and C type scale with the tare attachment were provided, and even-weight items received already packaged were priced with the self-inking stamp set instead of with plain white gummed labels on which the price is marked by hand. The display operation was improved by increasing the load carried to display from 10.7 packages to 16.1 packages.

These changes resulted in an increase of 22.7 percent in labor productivity in packaging and displaying, or a saving of 31.2 man-hours a week. In addition, materials costs were reduced \$10.20 a week.

In store No. 2, packaging methods were changed from wrapping with three seals to wrapping with one seal; the new easy-reach wrapping table was installed; and the film sizes were changed on the basis of the recommendations given in this report. For pricing, the separate label-printing machine and C type scale with the tare adjustment were installed. Even-weight items received already packaged were stamped with the self-inking stamp set instead of an adjustable band-type stamp. No changes were made in display.

The result of these changes was an increase of 9.8 percent in labor productivity for packaging, pricing, and displaying. This amounted to a saving of 10.6 man-hours a week. In addition, materials costs were reduced \$19.08 a week.

METHODOLOGY

The methods and equipment used in a number of stores of several different food chains in various parts of the country were examined before detailed studies were made. Close examinations of the operations in 52 stores of 3 firms in the southeastern part of the country were made, and 26 stores were selected for detailed studies. Studies were made in meat markets of 2 of the 26 stores in order to determine labor required to perform the various functions in self-service markets. One of these markets was 100-percent self-service, and the other was 90-percent self-service and also sold fresh fish and poultry over a service counter. All the employees in each market were timed for 1 week, and the total time required for them to perform the various market functions was determined. As a result of these studies it was decided to analyze packaging materials and to study in detail the market functions of receiving, blocking, cutting, packaging, displaying, and customer service. This publication covers the results obtained in the packaging and displaying operations of self-service markets.

These market functions were studied in 11 selected stores by analyzing and testing various methods, materials, equipment, and layouts with a view to recommending possible reductions in labor and materials costs.

Work methods for each function were separated into component parts called elements. With the use of the stop watch, each element was timed for a sufficient number of cycles to obtain a statistically reliable average time for each element for each operator studied. These times were rated in accordance with standard methods. ^{12/} The rating factor was applied to the average time for each element studied in order to convert actual performance of the operator studied to expected performance by the average operator using the same method. This in effect removed variation due to the speed of the operator.

Skill was not considered to be a factor in individual performance, because it was defined for the purposes of this study as the ability of the operator to follow a given motion pattern without hesitation. No operator was timed who did not have this ability. A fatigue and personal allowance factor of 15 percent was applied to the various elements for each study. ^{13/} Avoidable delays were excluded from each time study but all productive operations the operator performed and any unavoidable delay in a given operation were included. Set-up and clean-up times were

^{12/} Ralph Presgrave. The Dynamics of Time Study. (McGraw-Hill Publishing Company, New York, London) (1945.)

^{13/} The selection of the 15 percent figure is based on the Personal and Fatigue Allowance Table (p.370) in Motion and Time Study. By Dr. Ralph M. Barnes. John Wiley & Sons, (New York) (1949.)

not included except where these functions took place during the performance of an operation being studied, as, for example, cleaning the scale platform while weighing.

The basic unit of measurement in all studies in this report was the package. Those elements, which occurred less frequently than once for each package, were weighted on the basis of percentage of occurrence. For example, in a time standard some elements that occur for each pan of merchandise handled may be included; thus, the element "dispose of layer paper" might take 0.072 man-minute but would occur once per pan. It would then be included in the standard for T-bone steak as 0.072 times 12.2 percent (average of 8.2 T-bone steaks per pan) equals 0.009 man-minute per package. The weighted average elemental time requirements were added together to obtain the total time requirement for each operation. Fifteen percent of this time requirement was added for personal and fatigue allowance in order to obtain the standard time requirement per item. Personal and fatigue time represented the personal time required by the employee during the working day plus the rests needed to achieve continued production expected of the average worker. Standard time divided into 60 minutes per hour gave production in items per man-hour. In order to indicate the method of developing productivity figures examples of packaging and display standards for one item are shown in Appendix tables 30 and 31. Productivity figures thus developed for various commodities were averaged for each study to obtain comparative productivity figures for various methods, equipment, and similar items.

A time study was made of the various methods, materials, equipment, and layouts encountered and those developed during the study in the above-described manner and the standard time requirements were obtained to develop comparative productivity data. These productivity data plus cost information were used to evaluate the various methods, materials, equipment, and layouts.

APPENDIX

Table 24.--Variations in length of sheets of pliofilm torn from roll to fit specified packages of meat

Meat package	: Opera- : Sheets :		Length of sheet torn from roll		
	: tors :	:	: Shortest :	: Longest :	: Differences
	: Number:	: Number:	: Inches	: Inches	: Inches
Ground beef	: 1	: 10	: 9.000	11.000	2.000
Ground beef	: 1	: 10	: 8.500	10.750	2.250
Ground beef	: 4	: 10	: 10.250	14.250	4.000
Stew beef	: 3	: 5	: 9.500	10.250	.750
Ground beef	: 1	: 5	: 15.750	17.000	1.250
Sirloin steak	: 2	: 5	: 14.500	15.750	1.250
Chuck roasts	: 2	: 5	: 15.000	17.750	2.750
Neck bones	: 2	: 5	: 14.750	18.500	3.750
Veal cutlets	: 5	: 10	: 13.000	14.250	1.250
Veal sirloin	: 5	: 10	: 10.375	11.500	1.125
Veal chops	: 5	: 5	: 11.000	11.500	.500
Boston butts	: 1	: 10	: 14.750	16.750	2.000
Pork chops	: 1	: 10	: 10.250	13.250	3.000
Pork chops	: 1	: 10	: 10.000	12.250	2.250
Pork chops	: 5	: 10	: 9.750	12.500	2.750
Pork chops	: 5	: 10	: 13.500	14.625	1.125
Ham slices	: 2	: 10	: 11.750	14.000	2.250
Ham slices	: 2	: 5	: 13.500	16.500	3.000
Ham slices	: 5	: 10	: 15.000	16.500	1.500
Luncheon meat	: 2	: 10	: 9.750	11.500	1.750
Luncheon meat	: 2	: 10	: 9.500	11.750	2.250
Luncheon meat	: 4	: 10	: 8.500	9.375	.875
Luncheon meat	: 4	: 10	: 10.500	12.375	1.875
Fryers	: 1	: 10	: 14.250	15.750	1.500
Fryers	: 2	: 5	: 14.500	15.750	1.250
Fryers	: 5	: 5	: 14.500	16.750	2.250
Roasting chickens	: 1	: 5	: 19.000	21.500	2.500

Table 25.--Average yields in square inches per pound of roll film for packaging meats in test stores

Roll film	Thickness:	Width :	Average yield per pound ^{1/}	
	: of film:	: of roll:	: Square inches:	: Square inches
	: Gage :	: Inches :		
<u>Cellophane:</u>	:	:	:	:
Coated film	: 300 :	12 :	19,518	
	: 300 :	14 :	20,158	
	: 300 :	15 :	19,236	
Average 300-gage. . .	:	:		19,649
	: 450 :	18 :	14,268	
	: 450 :	20 :	14,538	
Average 450-gage. . .	:	:		14,331
<u>Uncoated film</u>	: 300 :	9 :	20,407	
	: 300 :	10 :	20,257	
	: 300 :	15 :	20,708	
Average 300-gage . . .	:	:		20,572
	: 450 :	18 :	14,112	
	: 450 :	20 :	13,951	
	: 450 :	24 :	14,270	
Average 450-gage . . .	:	:		14,071
<u>Pliofilm:</u>	:	:	:	:
	: 80 :	9 :	29,968	
	: 80 :	10 :	29,211	
	: 80 :	12 :	28,966	
	: 80 :	15 :	30,378	
	: 80 :	18 :	27,893	
Average 80-gage . . .	:	:		29,337

^{1/} These averages, found in the test stores, are not necessarily representative of the production of the various products indicated.

Table 26.--Film, board, and tray sizes previously used and the sizes recommended in test stores of one company 1/

Film sizes previously used		:	Film sizes recommended <u>2/</u>	
Kind of film	Inches	:	Kind of film	Inches
LSAT	9 x 9	:	LSAT	9 x 10
	10 x 10	:		11 x 12
	12 x 12	:		13 x 14
	15 x 15	:		15 x 16
	18 x 18	:		17 x 18
	20 x 20	:		19 x 20
MSAT	12 x 12	:	MSAT	11 x 12
	14 x 14	:		13 x 14
	15 x 15	:		15 x 16
	16 x 16	:		17 x 18
	18 x 18	:		
	20 x 20	:		
	24 x 24	:		
Board sizes previous used		:	Board sizes recommended	
	Inches	:		Inches
	3 1/2 x 9	:		3 1/2 x 9
	4 x 4	:		4 x 5
	4 x 5	:		5 x 7
	4 x 7	:		5 x 10
	5 x 10	:		6 x 8
	6 x 8	:		6 x 10
	10 x 8 x 2	:		8 x 6 x 1 3/4
Tray sizes previously used		:	Tray sizes recommended	
Code	Inches <u>3/</u>	:	Code	Inches <u>3/</u>
#1	5 x 5 x 1	:	#1	5 x 5 x 1
#2	8 x 5 1/2 x 1	:	#2	8 x 5 1/2 x 1
#3	9 x 7 x 1 3/4 (at top)	:		
	6 x 3 3/4 (at bottom)	:		
#5	10 x 5 x 1	:	#5	10 x 5 x 1
#6	10 x 6 x 1	:		

1/ Film sizes previously used required an average of 202.9 square inches per package. Film sizes recommended required 163.5 square inches per package. Recommended film sizes resulted in 19.4 percent savings in test stores. Board and tray sizes previously used cost 0.47 cent per package wrapped. Board and tray sizes recommended cost 0.45 cent per package wrapped. Recommended sizes resulted in an 8-percent saving in board and tray costs in test stores.

2/ These film sizes do not necessarily replace those on the same line in the opposite column. See table 27 for products for which these individual sizes are recommended.

3/ Outside dimensions.

Table 27.--Film and board or tray sizes recommended for packaging specified meat items in self-service test stores A and B of one company using cellophane

Meat item	Average package weight		Tray size	Board size	Film size
	Store A	Store B			
	Pounds	Pounds	Inches	Inches	Inches
<u>Beef:</u>					
Ground beef	0.87	0.91	5 x 5 x 1	-	11 x 12
Boneless stew beef99	1.04	5 x 5 x 1	-	11 x 12
Sirloin steak	1.19	1.83	-	6 x 10	13 x 14 or 15 x 16
T-bone steak65	1.05	-	5 x 7	11 x 12
Top round steak81	.97	-	6 x 8	13 x 14
Bottom round steak67	.83	-	5 x 10	13 x 14
Rib steak73	1.00	-	5 x 7	11 x 12
Loin tip steak71	.84	-	6 x 8	13 x 14
Chuck roast	2.62	3.69	-	8 x 6 x 1-3/4	13 x 14 or 15 x 16
Boneless chuck roast	2.46	-	-	8 x 6 x 1-3/4	13 x 14 or 15 x 16
Shoulder roast	-	3.55	-	8 x 6 x 1-3/4	13 x 14 or 15 x 16
Boneless shoulder roast.	3.21	-	-	8 x 6 x 1-3/4	13 x 14 or 15 x 16
English cut roast.	-	3.06	-	8 x 6 x 1-3/4	13 x 14 or 15 x 16
Rib roast	-	6.40	-	8 x 6 x 1-3/4	15 x 16 or 17 x 18
Rolled loin tip roast	-	4.83	-	-	13 x 14 or 15 x 16
Rump roast	2.88	3.53	-	-	17 x 18
Boneless rump roast	3.34	3.40	-	-	13 x 14 or 15 x 16
Short ribs98	-	5 x 5 x 1	-	11 x 12
Brisket beef73	-	-	4 x 5	11 x 12
Fresh tongue	3.64	2.57	10 x 5 x 1	-	13 x 14 or 15 x 16
<u>Veal:</u>					
Loin chops	-	.49	-	4 x 5	11 x 12
Rib chops	-	.62	-	4 x 5	11 x 12
Veal cutlets62	.85	-	6 x 8	13 x 14

Continued -

Table 27.--Film and board or tray sizes recommended for packaging specified meat items in self-service test stores A and B of one company using cellophane--Continued

Meat item	Average package weight		Tray size	Board size		Film size
	Store A	Store B		Inches	Inches	
	Pounds	Pounds	Inches	Inches	Inches	
<u>Veal (continued)</u>						
Veal sirloin70	1.05	-	5 x 7	11 x 12	
Shoulder steaks46	-	-	5 x 7	11 x 12	
Shoulder roast	2.36	-	-	5 x 7	13 x 14 or 15 x 16	
Veal rump roast	2.17	-	-	-	13 x 14 or 15 x 16	
Veal short ribs	1.08	-	5 x 5 x 1	-	11 x 12	
<u>Lamb:</u>						
Lamb stew93	-	5 x 5 x 1	-	11 x 12	
Lamb chops	-	.57	-	4 x 5	11 x 12	
Leg o' lamb	6.11	5.56	-	4 x 5	17 x 18 plus 11 x 12	
Half leg o' lamb	3.42	3.98	-	4 x 5	15 x 16 or 17 x 18	
Lamb shoulder	4.60	4.01	-	4 x 5	15 x 16 or 17 x 18	
Half lamb shoulder	3.25	-	-	4 x 5	15 x 16	
<u>Pork:</u>						
Center cut pork chops86	.83	-	5 x 7	11 x 12	
End cut pork chops83	1.16	-	5 x 10	13 x 14	
Pork cutlets66	.81	-	5 x 7	11 x 12	
Loin end pork roast	2.16	2.10	-	5 x 10	11 x 12	
Rib end pork roast	-	2.67	-	4 x 5	13 x 14 or 15 x 16	
Pork ham roast	-	7.98	-	4 x 5	13 x 14 or 15 x 16	
Pork backbone	-	1.81	8 x 5-1/2 x 1	-	13 x 14	
<u>Smoked meats:</u>						
Shank ham portion	7.98	-	-	-	19 x 20 plus 9 x 10	
Butt ham portion	4.85	-	-	-	17 x 18	

Table 27.--Film and board or tray sizes recommended for packaging specified meat items in self-service test stores A and B of one company using cellophane--Continued

Meat item	Average package weight		Tray size	Board size	Film size
	Store A	Store B			
	Pounds	Pounds	Inches	Inches	Inches
<u>Smoked meats (continued)</u>					
Center cut ham slices77	.67	-	6 x 8	15 x 16
End cut ham slices68	.59	-	5 x 7	11 x 12
Picnic ham	4.14	4.18	-	-	17 x 18
Half picnic ham	-	2.64	-	-	13 x 14
Bacon squares	-	2.20	-	-	11 x 12 or 13 x 14
Bacon pieces	-	1.75	-	-	11 x 12 or 13 x 14
Boneless rolled ham slices.	-	.47	-	5 x 7	11 x 12
Boneless rolled ham pieces.	-	3.30	-	-	13 x 14
Ham hocks.	1.59	1.18	5 x 5 x 1	-	11 x 12
Cottage ham butt	-	2.48	-	-	13 x 14
Beef tongue.	-	3.28	-	-	17 x 18
Ham fat	1.30	-	8 x 5-1/2 x 1	-	13 x 14
<u>Poultry:</u>					
Cut up frying chickens	2.07	2.16	8 x 5-1/2 x 1	-	15 x 16
Baking hens	4.21	4.26	10 x 5 x 1	-	17 x 18
Hen turkeys	-	4.99	-	-	19 x 20 plus 9 x 10
<u>Salt meat:</u>					
Streak o'lean	1.32	1.29	-	6 x 8	11 x 12 or 13 x 14
Sliced streak o'lean.	1.35	.86	-	-	15 x 16
Fat back93	1.32	-	-	11 x 12 or 13 x 14
<u>Lunch meat items:</u>					
Sliced lunch meats and cheeses.44	.39	-	-	9 x 10
Imported Swiss cheese wedges38	.48	-	-	9 x 10
Frankfurters59	.48	-	-	11 x 12
Dinner size franks66	-	-	-	11 x 12
Pork sausage	1.00	.50	-	-	11 x 12
Canadian bacon sliced30	.35	-	3-1/2 x 9	11 x 12
Liver cheese sliced.37	.24	-	4 x 5	9 x 10

Table 28.--Percentages that total price occurrences of specified prices per pound for meats were of the total number of price occurrences found in a survey of meat markets in 12 cities, January 1, 1952 ^{1/}

Price per pound	Total pricing: observation : percentage	Price per pound	Total pricing: observation : percentage	Price per pound	Total pricing: observation : percentage
Dollars	Percent	Dollars	Percent	Dollars	Percent
0.21	0.02	0.63	3.36	1.03	0.11
.23	.02	.64	.52	1.04	.11
.25	.28	.65	8.13	1.05	.33
.26	.02	.66	.50	1.06	.09
.27	.09	.67	1.29	1.08	.44
.28	.09	.68	1.11	1.09	.42
.29	1.29	.69	9.67	1.10	.92
.30	.11	.70	1.29	1.11	.15
.31	.02	.71	.37	1.12	.13
.32	.15	.72	.81	1.13	.17
.33	.24	.73	1.29	1.14	.31
.34	.04	.74	.50	1.15	.37
.35	1.35	.75	4.65	1.16	.04
.36	.02	.76	.17	1.17	.26
.37	.09	.77	.33	1.18	.22
.38	.09	.78	1.01	1.19	.92
.39	2.84	.79	5.09	1.20	.52
.40	.35	.80	.46	1.21	.04
.41	.13	.81	.26	1.22	.31
.42	.15	.82	.26	1.25	.26
.43	.96	.83	.79	1.26	.17
.44	.31	.84	.17	1.27	.04
.45	2.75	.85	1.88	1.28	.04
.46	.28	.86	.17	1.29	.59
.47	.96	.87	.22	1.30	.20
.48	.48	.88	.28	1.35	.22
.49	6.47	.89	2.73	1.38	.02
.50	.59	.90	.57	1.39	.28
.51	.66	.92	.20	1.40	.09
.52	.42	.93	.22	1.41	.04
.53	1.90	.94	.11	1.42	.02
.54	.83	.95	.50	1.43	.02
.55	3.60	.96	.07	1.44	.02
.56	.57	.97	.17	1.45	.15
.57	.94	.98	.87	1.49	.31
.58	.63	.99	.26	1.50	.07
.59	8.26	1.00	.15	1.55	.09
.60	1.29	1.01	.04	1.59	.11
.61	.70	1.02	.11	1.60	.13
.62	.70				100.00

^{1/} Based on 4,577 observations in 7 large and 5 medium cities on January 1, 1952. Source: Bureau of Labor Statistics, Dept. of Labor.

Table 29.--Prices per pound on specified computing scales for prepackaging in self-service meat markets

Scale (code letter)	Prices (cents per pound)																
A . .	15	23	30	36	41	46	51	56	63	69	77	83	90	97	105	115	125
	17	25	31	37	42	47	52	57	64	70	79	85	91	98	107	117	130
	19	27	32	38	43	48	53	59	65	71	80	87	92	99	109	119	135
	20	28	33	39	44	49	54	60	67	73	81	88	93	100	110	120	140
	21	29	35	40	45	50	55	61	68	75	82	89	95	103	113	123	150
	equals 85 prices or 91.08 percent of prices found in Bureau of Labor survey of meat market prices.																
B . .	Odd number prices 19 through 39 plus all prices between 40 and 100, except those ending in 4 or 6, plus 105, 109, 110, 115, 119, 125, 139 equals 67 prices or 89.90 percent of survey prices.																
C (New plate)	All prices 19 through 115 plus 117, 119, 120, 121, 123, 125, 127, 129, 130, 131, 133, 135, 137, 139, 140, 141, 143, 145, 147, 149, 150, 155, 160, 165, 170, 175, 180 equals 124 prices or 99.05 percent of survey prices.																
C (Old plate)	All prices 10 to 100 plus 103, 105, 107, 110, 113, 115, 117, 120, 125, 130, 140, 150 equals 103 prices or 94.42 percent of survey prices.																
D . .	All prices 17 through 43 plus odd prices 45 through 99 plus 100 equals 56 prices or 75.95 percent of survey prices.																
Combination scale and label printer:	15	25	35	43	48	54	59	65	70	76	82	87	93	98	104	109	115
	17	27	37	44	49	55	60	66	72	77	83	88	94	99	105	110	116
	19	29	39	45	50	56	62	67	73	78	84	89	95	100	106	112	117
	21	30	40	46	52	57	63	68	74	79	85	90	96	102	107	113	118
	23	33	42	47	53	58	64	69	75	80	86	92	97	103	108	114	119
													120	126	133	143	
													122	127	135	145	
													123	128	137	147	
													124	129	139	149	
													125	130	140	150	
	equals 105 prices or 96.79 percent of survey prices.																
Separate label printing machine:	This machine will print all prices per pound up to \$9.99.																

Table 30.--Time requirements in production standard for packaging T-bone steak, using conventional methods, in a self-service meat market 1/

Element	Basic	Frequency	Total	Frequency	Weighted ele-
	elemental time	Percent	time	package	mental time per package
	Man-minutes	Man-minutes	Man-minutes	Percent	Man-minutes
Obtain and position film, product and board	-	-	0.163	100.0	0.163
Wrap and seal	-	-	.177	100.0	.177
Attach label and dispose	-	-	.079	100.0	.079
Weigh, price and dispose	-	-	.163	100.0	.163
<u>Per pan:</u>					
Adjust scale	0.147	122.2	.180		
Check price of product132	12.1	.016		
Dispose of pan058	1.0	.001		
Dispose of pan table to conveyor083	57.0	.047		
Record number of package069	73.8	.051		
Obtain pan, conveyor to wrap table055	50.0	.028		
Obtain pan, conveyor to scale table053	88.3	.047		
Move pan on conveyor to wrap table058	29.8	.017		
Move pan on conveyor to scale143	7.4	.011		
Move packages pan to scale111	6.4	.007		
Obtain cellophane132	17.8	.023		
Obtain pan at scale095	2.0	.002		
Place package on pan on conveyor165	15.3	.025		
Place package on pan on table265	18.5	.049		
Change film size107	3.2	.003		
Perform additional trim100	2.2	.002		
Obtain empty pan059	1.6	.001		
Walk to scale127	2.1	.003		

See footnote at end of table.

Table 31.--Time requirements in production standard for displaying T-bone steak using conventional methods in a self-service meat market 1/

Element	Basic elemental time		Frequency		Total elemental time		Frequency per package		Weighted elemental time per package	
	Man-minutes	Percent	Percent	Man-minutes	Percent	Man-minutes	Percent	Man-minutes	Man-minutes	
Display product	-	-	-	0.048	100.0	0.048	100.0	0.48		
Per pan:										
Carry product to counter	0.130	74.9		.097						
Dispose empty pan to package room082	100.0		.082						
Dispose empty pan to package room to cutting room042	100.0		.042						
Rotate merchandise in case239	51.7		.124						
Dispose product scale to holding cooler205	25.1		.051						
Talk to customer430	4.7		.020						
Walk to scale130	6.2		.008						
Search holding cooler for product137	2.4		.003						
Talk with head meat cutter regarding product requirements	1.390	.5		.007						
Return excess product to holding cooler150	.9		.001						
Arrange product in holding cooler226	.9		.002						
Inspect case for product requirements132	.5		.001						
Remove product from holding cooler, carry to case267	23.2		.062						
Walk to inside door of holding cooler126	1.9		.002						
Remove product from inside door of holding cooler, carry to display212	1.9		.004						
Inspect products in case525	.5		.003						
Inspect products in holding cooler252	5.2		.013						
Rearrange products in case631	10.0		.063						
Walk down case231	.5		.001						
Delay for 2-man team for cleaning case452	.5		.002						
Obtain product from cutting room cooler672	.9		.006						
Total per pan times594	12.2			.072		
Total display time120		
Personal and fatigue allowance (15 percent)018		
Standard time per package138		
Packages per man-hour								434.8		

1/ Average package weight 0.94 pound.

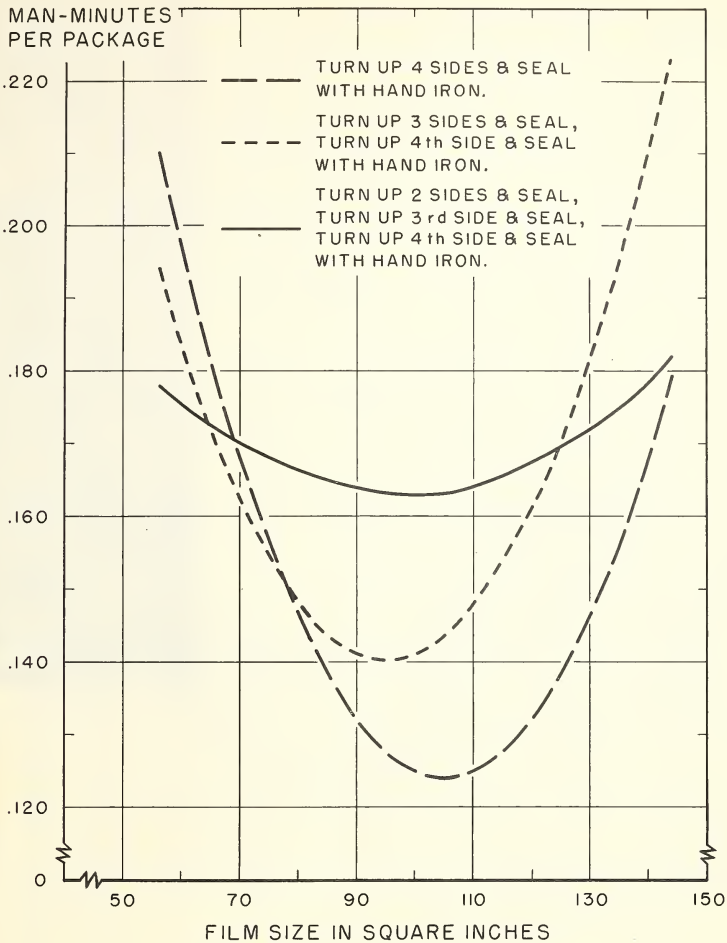

Figure 28.--Time requirements to obtain, position, wrap, seal, and dispose of round luncheon meat packages, using various sizes of cellophane and different wrapping methods.

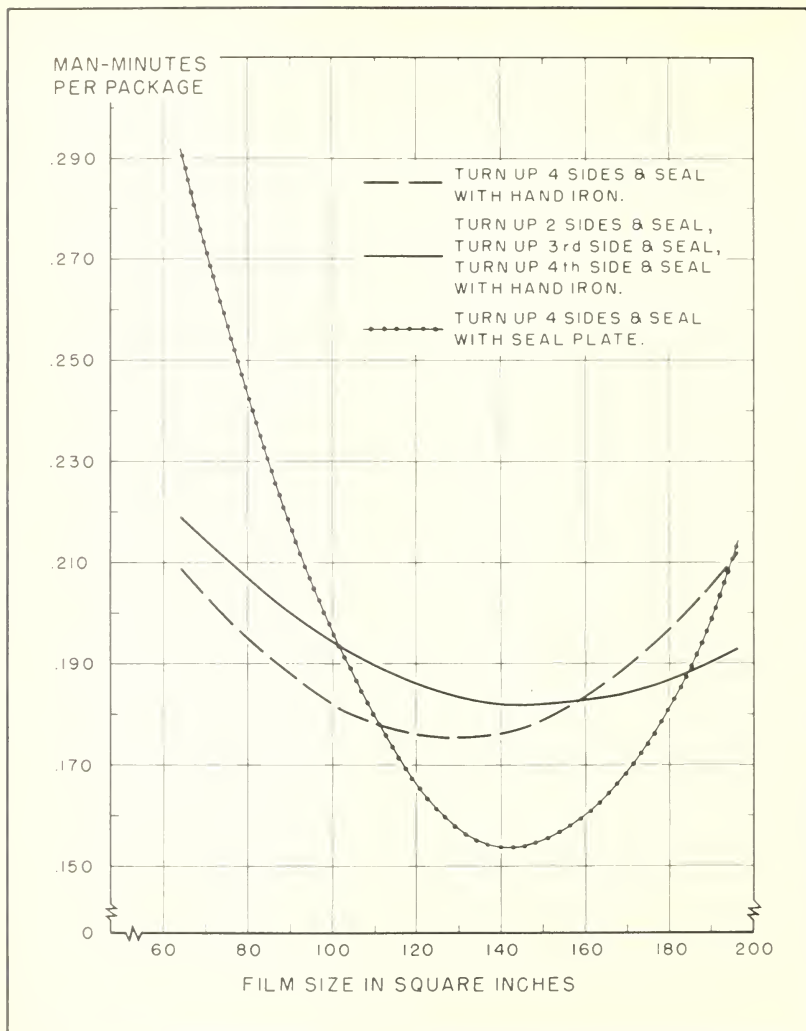
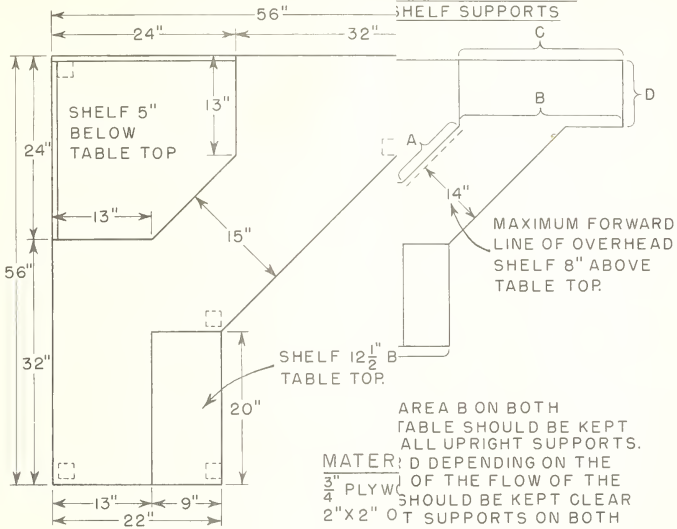
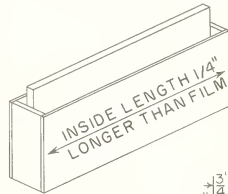
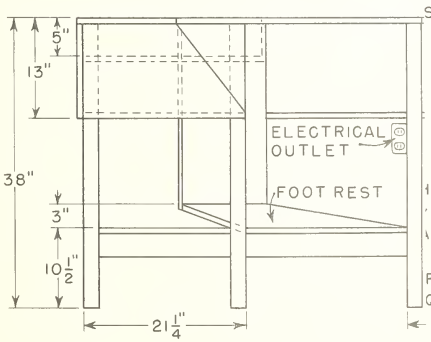

Figure 29.--Time requirements to obtain, position, wrap, seal, and dispose of round luncheon meat packages using various sizes of pliofilm and different wrapping methods.

POSITION OF UPRIGHT
SHELF SUPPORTS



AREA B ON BOTH TABLE SHOULD BE KEPT ALL UPRIGHT SUPPORTS. MATERIAL D DEPENDING ON THE 3/4" PLYWOOD OF THE FLOW OF THE SHOULD BE KEPT CLEAR 2" X 2" OF SUPPORTS ON BOTH TABLE THE TABLE. HEAT RESISTANT TRAY FOR CELLOPHANE



WICK FOR FILM 20" SQUARE OR SMALLER
TRAY FOR FILM 14" SQUARE OR SMALLER
DIMENSIONS ADJUSTED TO FILM NAILED IN PLACE

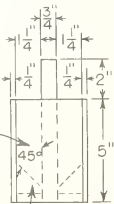

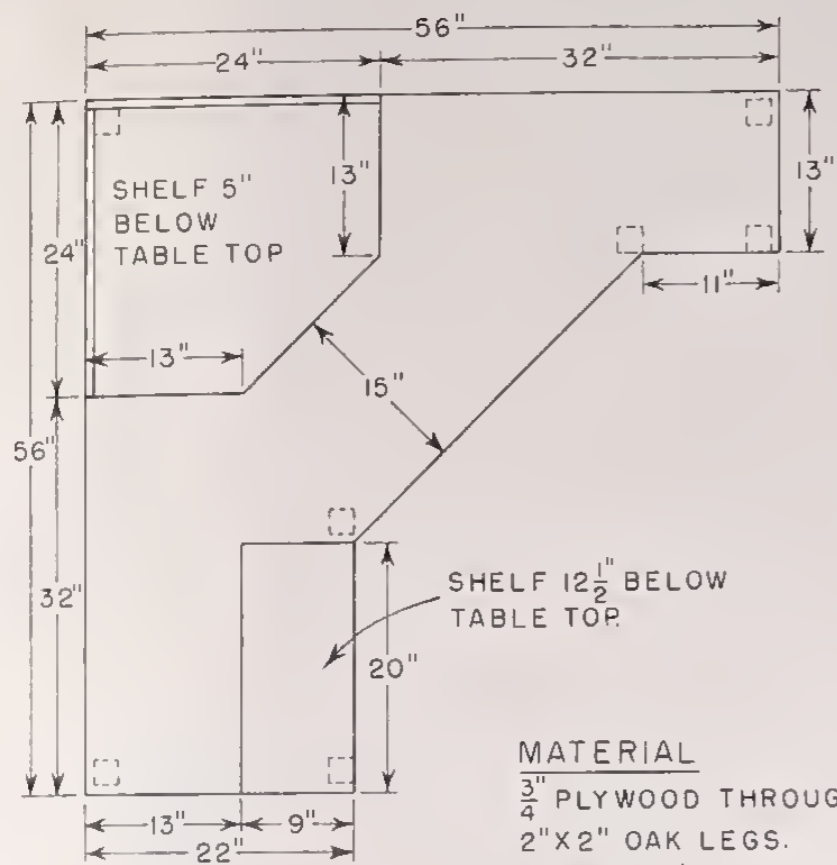

MATERIAL
 3/4" PLYWOOD THROUGHOUT.
 2" X 2" OAK LEGS.
 TABLE TOP OF WASHABLE
 HEAT RESISTANT MATERIAL.

**ISOMETRIC VIEW
 DO NOT SCALE**

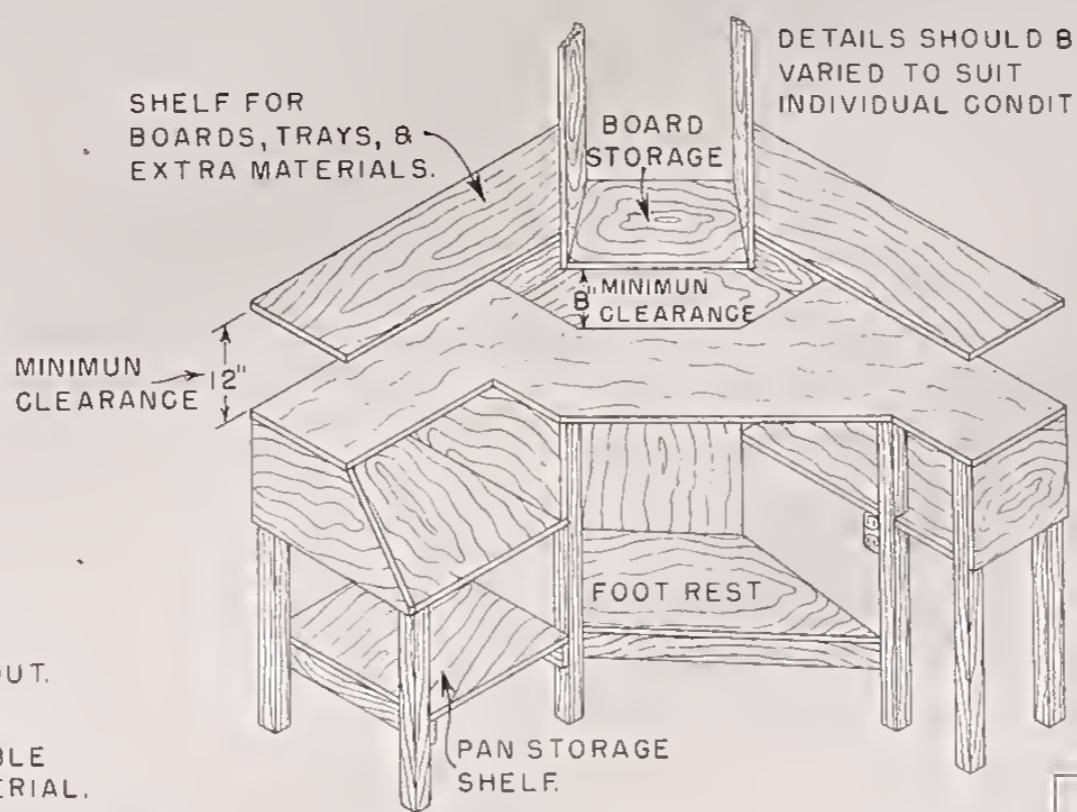

DETAILS SHOULD BE
 VARIED TO SUIT
 INDIVIDUAL CONDITIONS.

**LOCATION OF UPRIGHT
 SHELF SUPPORTS**

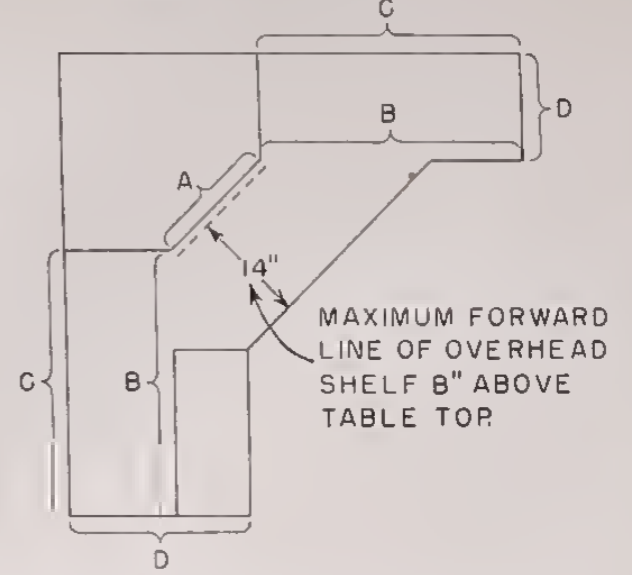

AREA A & AREA B ON BOTH
 SIDES OF TABLE SHOULD BE KEPT
 CLEAR OF ALL UPRIGHT SUPPORTS.
 AREA C OR D DEPENDING ON THE
 DIRECTION OF THE FLOW OF THE
 PRODUCT SHOULD BE KEPT CLEAR
 OF UPRIGHT SUPPORTS ON BOTH
 SIDES OF THE TABLE.

SCALE OF INCHES

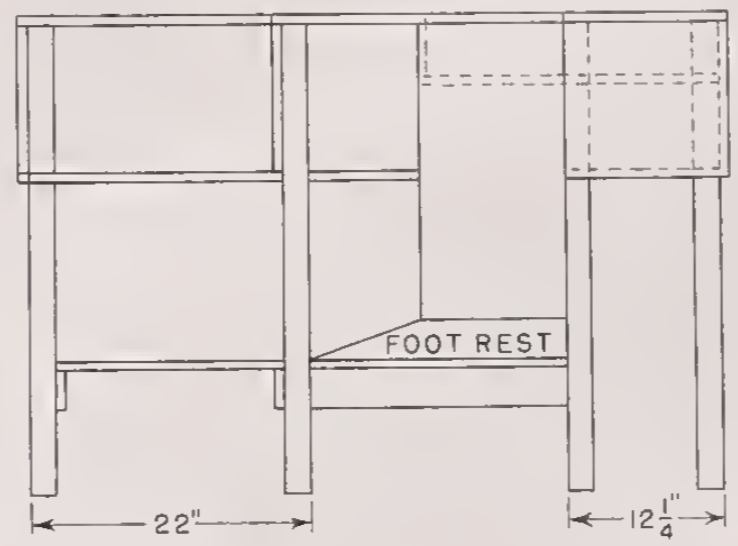
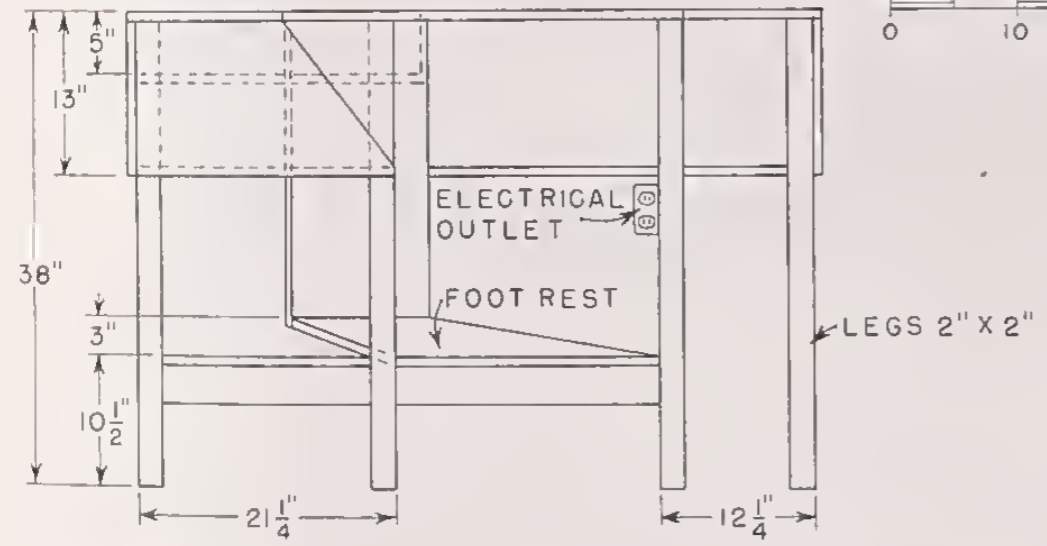
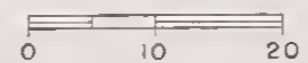

FOLD-OVER TRAY FOR CELLOPHANE

SCALE OF INCHES

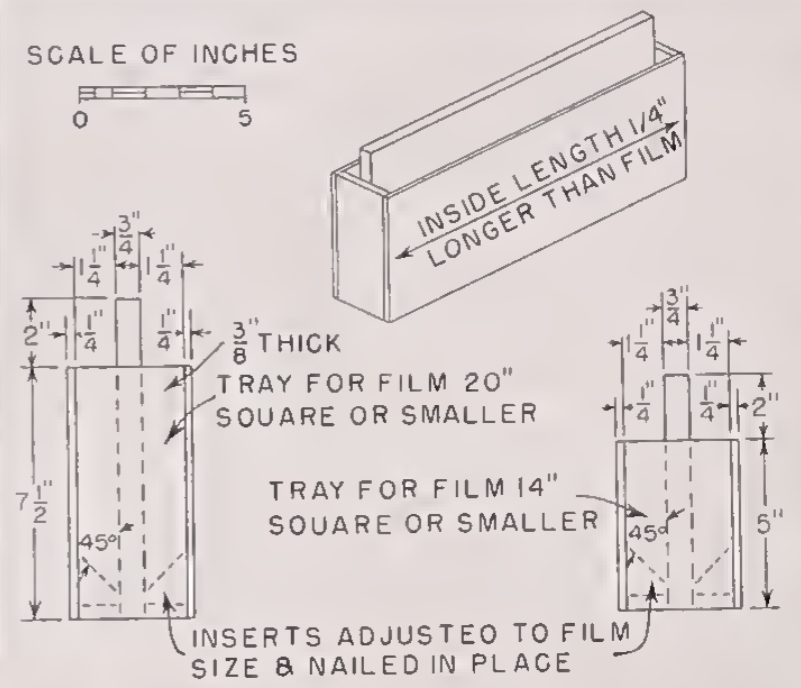

Figure 30.--Construction details for easy-reach wrapping table and fold-over film tray.

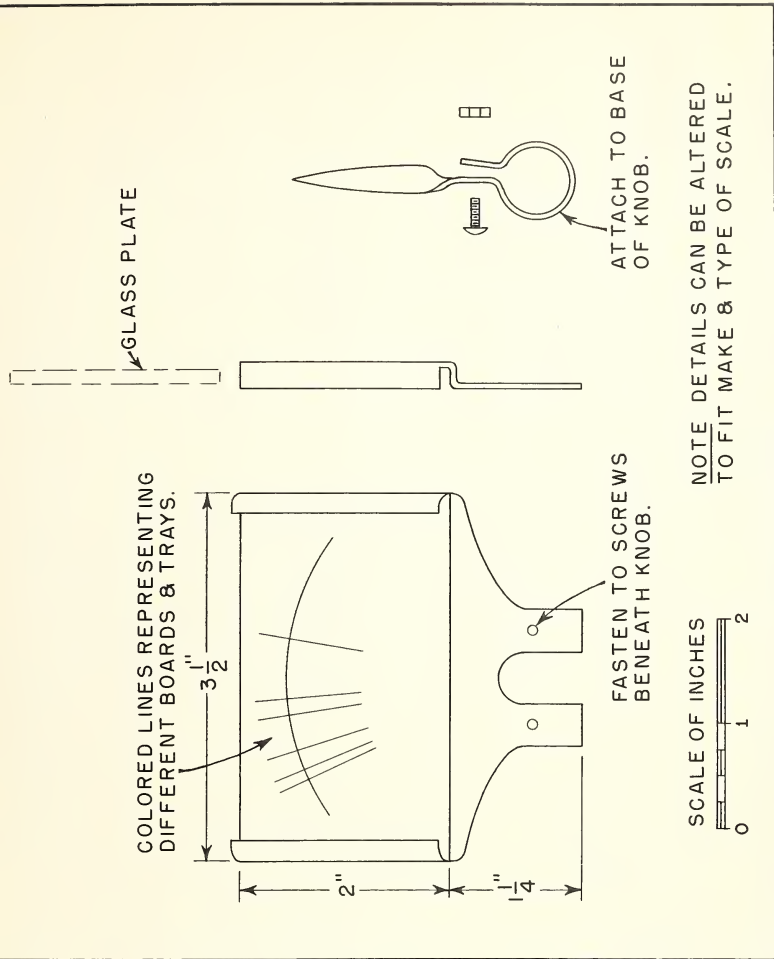

Figure 31.--Construction details for a simple tare set attachment for a prepackaging scale.

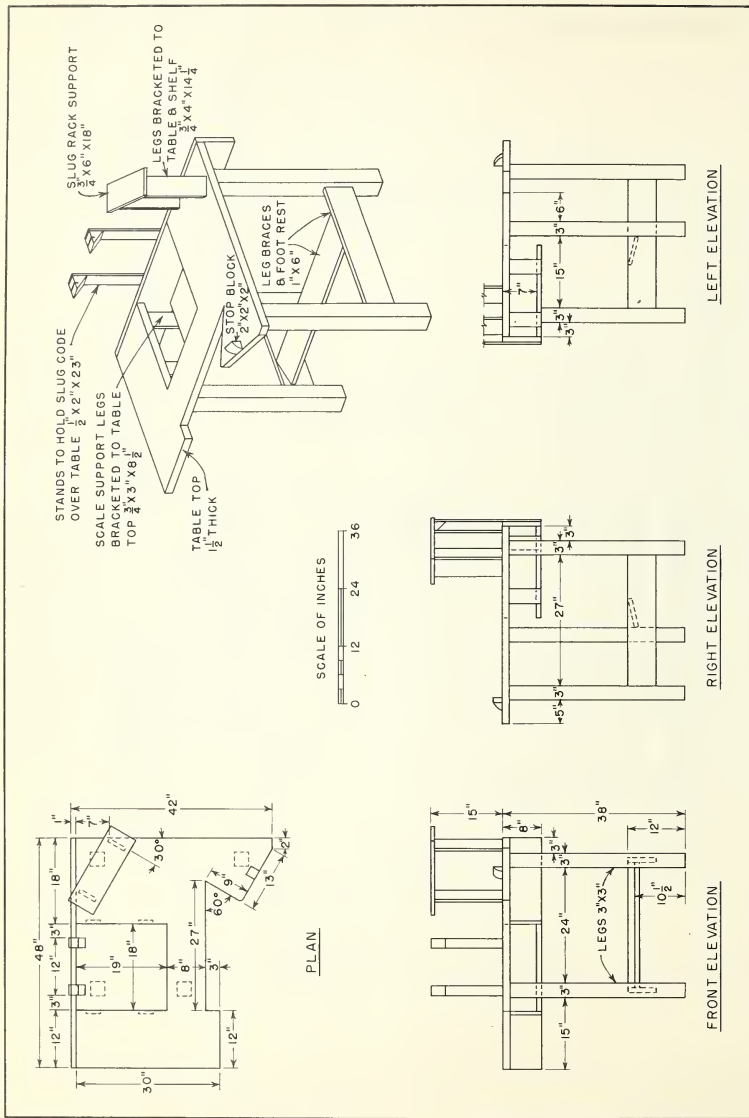

Figure 32.--Construction details for a worktable for the separate label-printing machine and a scale.

