



AgEcon SEARCH
RESEARCH IN AGRICULTURAL & APPLIED ECONOMICS

The World's Largest Open Access Agricultural & Applied Economics Digital Library

This document is discoverable and free to researchers across the globe due to the work of AgEcon Search.

Help ensure our sustainability.

Give to AgEcon Search

AgEcon Search

<http://ageconsearch.umn.edu>

aesearch@umn.edu

*Papers downloaded from **AgEcon Search** may be used for non-commercial purposes and personal study only. No other use, including posting to another Internet site, is permitted without permission from the copyright owner (not AgEcon Search), or as allowed under the provisions of Fair Use, U.S. Copyright Act, Title 17 U.S.C.*

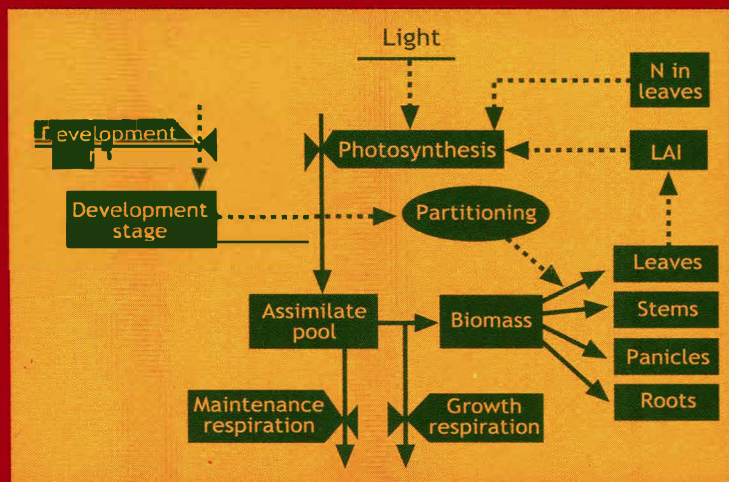

ORYZA2000:

modeling
lowland
rice

B.A.M. Bouman
M.J. Kropff
T.P. Tuong
M.C.S. Wopereis
H.F.M. ten Berge
H.H. van Laar



IRRI

ORYZA2000: modeling lowland rice

B.A.M. Bouman

International Rice Research Institute

M.J. Kropff

Wageningen University and Research Centre

T.P. Tuong

International Rice Research Institute

M.C.S. Wopereis

West Africa Rice Development Association

H.F.M. ten Berge

Wageningen University and Research Centre

H.H. van Laar

Wageningen University and Research Centre

2001

IRRI

WAGENINGEN UR

The International Rice Research Institute (IRRI) was established in 1960 by the Ford and Rockefeller Foundations with the help and approval of the Government of the Philippines. Today IRRI is one of 16 nonprofit international research centers supported by the Consultative Group on International Agricultural Research (CGIAR). The CGIAR is cosponsored by the Food and Agriculture Organization of the United Nations (FAO), the International Bank for Reconstruction and Development (World Bank), the United Nations Development Programme (UNDP), and the United Nations Environment Programme (UNEP). Its membership comprises donor countries, international and regional organizations, and private foundations.

As listed in its most recent Corporate Report, IRRI receives support, through the CGIAR, from a number of donors including UNDP, World Bank, European Union, Asian Development Bank, and Rockefeller Foundation, and the international aid agencies of the following governments: Australia, Bangladesh, Belgium, Brazil, Canada, People's Republic of China, Denmark, France, Germany, India, Islamic Republic of Iran, Japan, Republic of Korea, The Netherlands, Norway, Philippines, Spain, Sweden, Switzerland, Thailand, United Kingdom, and United States.

The responsibility for this publication rests with the International Rice Research Institute.

The designations employed in the presentation of the material in this publication do not imply the expression of any opinion whatsoever on the part of IRRI concerning the legal status of any country, territory, city, area, or of its authorities, or the delimitation of its frontiers or boundaries.

Wageningen University and Research Centre (Wageningen UR) is an alliance between a university and market-oriented research institutes. Wageningen UR combines fundamental and applied research with innovative education in the areas of food, agrotechnology, production systems, nature, and the environment. Its research and education activities focus on ensuring reliable supplies of safe, high-quality food while maintaining the biodiversity of natural habitats and conserving natural resources.

Copyright International Rice Research Institute 2001

Mailing address: DAPO Box 7777, Metro Manila, Philippines

Phone: (63-2) 845-0563, 844-3351 to 53

Fax: (63-2) 891-1292, 845-0606

Email: irri@cgiar.org

Home page: www.irri.org

Riceweb: www.riceweb.org

Riceworld: www.riceworld.org

Courier address: Suite 1009, Pacific Bank Building

6776 Ayala Avenue, Makati City, Philippines

Tel. (63-2) 891-1236, 891-1174, 891-1258, 891-1303

Suggested citation:

Bouman BAM, Kropff MJ, Tuong TP, Wopereis MCS, ten Berge HFM, van Laar HH. 2001. ORYZA2000: modeling lowland rice. Los Baños (Philippines): International Rice Research Institute, and Wageningen: Wageningen University and Research Centre. 235 p.

EDITOR: Bill Hardy

COVER DESIGN: Juan Lazaro IV

PAGE MAKEUP AND COMPOSITION: Gon van Laar

ISBN 971-22-0171-6

Contents

Foreword	vii
1 Introduction	1
2 The model ORYZA2000	3
2.1 The FORTRAN Simulation Environment (FSE)	3
2.2 The subroutine MODELS	6
2.2.1 The scientific simulation modules of ORYZA2000	6
2.2.2 Subroutine MODELS: program statements	7
2.3 The WEATHER system	17
2.4 Utility functions and subroutines	19
2.4.1 Functions	19
2.4.2 Subroutines	20
<i>Subroutines for reading data</i>	20
<i>Subroutines for writing data</i>	21
<i>Unit numbers and file names</i>	22
3 Crop growth and development	23
3.1 Initial conditions	25
3.2 Rate calculations	28
3.2.1 Phenological development	30
<i>Effective temperature for phenological development</i>	30
<i>Low temperature and crop survival</i>	32
<i>Phenological development rate</i>	33
<i>Drought stress and development rate</i>	34
3.2.2 CO ₂ assimilation of the canopy	36
<i>Gross CO₂ assimilation and light absorption</i>	36
<i>Daily canopy photosynthesis</i>	38
<i>Astronomical parameters</i>	41
<i>Diffuse and direct radiation</i>	43
<i>Instantaneous canopy CO₂ assimilation</i>	45
<i>Maximum leaf photosynthesis rate</i>	47
<i>Absorbed radiation</i>	49
3.2.3 Dry matter partitioning	52
3.2.4 Loss of green leaves and stem reserves	53
3.2.5 Respiration	54
<i>Maintenance respiration</i>	54
<i>Growth respiration</i>	56
3.2.6 Crop growth rate	56

3.2.7	Growth rates of crop organs	57
3.2.8	Spikelet and grain formation	58
3.2.9	Leaf area growth	63
	<i>Transplanted rice: growth in seedbed</i>	65
	<i>Transplanted rice: transplanting and transplanting shock</i>	67
	<i>Transplanted rice: after transplanting</i>	69
	<i>Direct-seeded rice</i>	70
3.2.10	Leaf death caused by drought	71
3.2.11	Crop growth rate and carbon balance check	72
3.3	Integration of states	73
3.4	Terminal section	76
4	Evapotranspiration and water stress	79
4.1	Potential evapotranspiration	79
4.2	Drought stress	84
4.2.1	Leaf rolling and spikelet sterility	87
4.2.2	Leaf expansion, flowering time time, assimilate partitioning, and rooting depth	88
4.2.3	Accelerated leaf senescence	90
4.2.4	Relative and actual transpiration rate	90
4.2.5	Water uptake compensation	93
4.2.6	Relative photosynthesis rate	94
4.2.7	Terminal section	94
4.3	Non-water-limited growth	95
5	Nitrogen dynamics	97
5.1	Crop nitrogen status	97
5.1.1	Nitrogen demand by crop organs	98
5.1.2	Nitrogen translocation	102
5.1.3	Nitrogen uptake	103
5.1.4	Nitrogen in the crop	104
5.1.5	Nitrogen stress effects	106
	<i>Effect on photosynthesis</i>	107
	<i>Effect on relative growth rate of leaves</i>	108
	<i>Effect on leaf death rate</i>	108
5.1.6	Simulation run check	109
5.1.7	Nitrogen balance check	109
5.2	The soil nitrogen supply	110
5.2.1	Rate calculations	111
5.2.2	State calculations	112
5.3	Non-nitrogen-limited growth	112

6	Soil-water balance	115
6.1	The lowland rice soil	115
6.2	The soil-water balance model PADDY	118
6.2.1	Initial conditions	119
	<i>Soil profile definition and switch settings</i>	120
	<i>Shrinkage, cracking, and groundwater table</i>	122
6.2.2	Rate equations	123
	<i>Ponded water</i>	124
	<i>Dynamic calculation of percolation rate</i>	130
	<i>No ponded water</i>	132
	<i>Drainage to groundwater</i>	133
	<i>Capillary rise</i>	134
	<i>Soil water content</i>	136
6.2.3	Integration of states	136
	<i>Groundwater depth</i>	136
	<i>Water content</i>	137
	<i>Shrinkage and cracking</i>	139
	<i>Soil-water tension</i>	140
	<i>Water balance check</i>	141
6.2.4	Other subroutines used by PADDY	142
6.3	Irrigation	143
7	ORYZA2000 data files	149
7.1	The control file CONTROL.DAT	150
7.2	The experimental data file	153
7.3	The crop data file	164
7.4	The soil data file	177
7.5	The weather data file	185
7.6	The rerun file	187
7.7	The output files	188
8	Model installation, running, and calibration	191
8.1	Installation and running of ORYZA2000	191
8.1.1	Example data sets	191
8.1.2	Model running under CVF	194
8.1.3	Model running as executable	195
8.2	Model calibration	196
8.3	Model validity domain	200
8.4	Model applications	203
References		205
List of variables		215
Index		231

Foreword

Crop modeling and systems analysis have become important tools in modern agricultural research. A crop model synthesizes our insights into the physiological and ecological processes that govern crop growth into mathematical equations. Our understanding of crop performance is tested by comparing simulation results with experimental observations, thus making the gaps in our knowledge explicit. Experiments can then be designed to fill these gaps. Once a model is validated, it can be used to help analyze and interpret field experiments. It can also be used in application-oriented research such as the design of crop ideotypes, the analysis of yield gaps, the optimization of crop management, the ex ante analysis of the effects of climate change on crop growth, and agroecological zonation.

IRRI has been involved in crop modeling since the 1970s, with the development of IRRIMOD and RICEMODE. From 1984 to 1995, IRRI participated in the project SARP (Simulation and Systems Analysis for Rice Production), which involved collaboration with the Wageningen University and Research Centre (WUR) and 16 national agricultural research and extension systems in Asia. In this project, the generic crop growth model MACROS was released, which was followed by the ORYZA model series for rice. Since then, modeling efforts at IRRI have continued with the extension and application of the ORYZA series. This book documents the model ORYZA2000, which integrates and updates previous models in the ORYZA series. ORYZA2000 simulates growth and development of lowland rice under conditions of potential production, water limitations, and nitrogen limitations. The model was developed in close cooperation with WUR. A CD-ROM in the back of this book contains the source code of the model and three sets of example data files. Through this, readers are encouraged to experiment with the model and apply it in their own research.

Ronald P. Cantrell
Director General, IRRI

1 Introduction

This book documents the ecophysiological crop model ORYZA2000 to simulate the growth, development, and water balance of lowland rice. ORYZA2000 follows the principles of the “School of de Wit” crop growth simulation models (Bouman et al 1996). It simulates the growth and development of a rice crop in situations of potential production, water limitations, and nitrogen limitations (de Wit and Penning de Vries 1982):

- *Potential production.* Growth occurs in conditions with an ample supply of water and nutrients; growth rates are determined by varietal characteristics and weather conditions only (radiation and temperature).
- *Water-limited production.* Growth is limited by a water shortage in at least part of the growing period; nutrients are in ample supply.
- *Nitrogen-limited production.* Growth is limited by a shortage of nitrogen (N) in at least part of the growing season.

In all production situations, the crop is supposed to be well protected against diseases, pests, and weeds and no reductions in yield occur.

ORYZA2000 is the successor to a series of rice growth models developed in the 1990s in the project “Simulation and Systems Analysis for Rice Production (SARP)” (ten Berge and Kropff 1995). It is an update and integration of the models ORYZA1 for potential production (Kropff et al 1994a), ORYZA_W for water-limited production (Wopereis et al 1996a), and ORYZA-N for nitrogen-limited production (Drenth et al 1994). Since the release of these models, new insights into crop growth and water-balance processes have been gained, new scientific subroutines developed, and programming standards and tools improved. These developments warranted a new release in the ORYZA series. Besides the scientific and programming updates, ORYZA2000 contains new features that allow a more explicit simulation of crop management options, such as irrigation and nitrogen fertilizer management.

Chapter 2 of this book describes the general structure of ORYZA2000 and the so-called FORTRAN Simulation Environment (FSE) in which it is programmed. Chapter 3 gives a complete description of the crop growth processes modeled. Chapter 4 describes how evapotranspiration is computed and how effects of water stress on crop growth and development are calculated. Chapter 5 describes the nitrogen balance in the crop and the calculation of nitrogen stress factors that affect crop growth and development. It also describes the subroutine that computes the availability and uptake of nitrogen from the soil. Chapter 6 documents the soil-water balance model PADDY. Chapter 7 explains the input data files needed to run ORYZA2000 and the generated output files. Each parameter and its corresponding value in the input data files are explained in detail. The last chapter, Chapter 8, explains how to install

ORYZA2000 from a CD-ROM, set up data files, and run the model. Two other programs designed to assist in model parameterization are explained here: DRATES and PARAM. Separate paragraphs describe the validity domain and practical applications of ORYZA2000. The list of variables at the end of the book describes all the variables used in ORYZA2000.

The CD-ROM in the back of this book contains the model ORYZA2000, its source code, and three sets of example data files. The only source code not made available is that of three libraries of nonscientific utility routines and functions (TTUTIL, WEATHER, and OP_OBS). Besides ORYZA2000, the programs DRATES and PARAM for model parameterization and the program TTSELECT for quick-viewing of simulation results are included. Chapter 8 details how to install these programs from the CD-ROM on a computer for further use. ORYZA2000 uses several scientific subroutines and nonscientific libraries that have been documented elsewhere. Since these documents are mostly technical reports with limited copies, they have been included on the CD-ROM with permission from the authors. They are reports on the libraries TTUTIL (van Kraalingen and Rappoldt 2000) and WEATHER (van Kraalingen et al 1991), on the evapotranspiration models (van Kraalingen and Stol 1997), on the FORTRAN Simulation Environment (FSE; van Kraalingen 1995), and on the program TTSELECT (van Kraalingen, unpublished document). Though much care has been taken to make the software easy to use and free of errors, please remember that the software originated in an academic environment and was not designed for commercialization. Models are never finished and need continued updating as new insights develop. Also, researchers may have different opinions on how to (mathematically) model certain processes of crop growth. By providing the source code of ORYZA2000, we encourage users to experiment with the model and make changes or additions according to their own insights and model needs.

ORYZA2000 has a long history and many people have contributed directly or indirectly to its creation. Special thanks are due to D.W.G. van Kraalingen, who designed and programmed most of the overall modeling structure and the technical libraries, and programmed many of the scientific subroutines used by ORYZA2000. Part of this book is based on earlier descriptions of ORYZA models, by Drenth et al (1994), Kropff et al (1994a), and Wopereis et al (1996a).

2 The model ORYZA2000

The model ORYZA2000 simulates growth and development of lowland rice in situations of potential production, water limitation, and nitrogen limitation (Chapter 1). To simulate all these production situations, several modules are combined in ORYZA2000: modules for aboveground crop growth, evapotranspiration, nitrogen dynamics, soil-water balance, and many more. To ease the linkage between these modules, they are all programmed in the FORTRAN Simulation Environment (FSE) as developed by van Kraalingen (1995). The FSE system was especially designed for the programming of models that dynamically simulate agroecological growth processes, such as those of crops, and that require daily weather data as input. The next sections provide a brief explanation of the FSE system, followed by a summary description of the scientific simulation modules that are included in ORYZA2000, an explanation of a special system to handle weather data in FSE, and a summary of the important utility functions and subroutines used.

2.1 The FORTRAN Simulation Environment (FSE)

Van Kraalingen (1995) gave a detailed description of the FSE, which is included on the CD-ROM accompanying this book. This Section gives a summary description with special reference to the implementation of ORYZA2000.

The FSE system consists of a main program, called FSE, a library for the handling of weather data, called WEATHER (van Kraalingen et al 1991), a utility library for specific tasks (such as the reading and writing of input and output data, linear interpolation, etc.), called TTUTIL (van Kraalingen and Rappoldt 2000), and a set of programming guidelines. The most important programming guideline for any model to be linked to the FSE system is that it uses the rate-state concept of simulation modeling (Penning de Vries and van Laar 1982, van Keulen and Wolf 1986, Leffelaar 1993). In this concept, a simulation starts at the beginning of a time step, usually a day, with a certain value for its state variables. Examples of state variables in crop models are the weights of crop organs (leaves, stems, roots) and the leaf area index. Then the rates of change are calculated for the specific time step under consideration. Examples of rates of change are the daily growth rates of the crop organs. At the end of the time step, the state variables are updated by integrating the rates of change over the time step. In ORYZA2000, the time step of integration is 1 day. A dynamic simulation is realized by repeating the rate calculations and state integration for several time steps until a certain finish condition is met. For crop growth, a complete simulation run simulates growth from emergence to harvest. A simulation model that runs under the FSE system should have all

calculations and statements divided into four sections. The sections are defined by the variable ITASK. The first section (ITASK = 1) is the initialization section, and it should contain statements that are executed only once at the beginning of a simulation, such as reading model parameters from data files and setting the initial conditions of state and rate variables. The second section (ITASK = 2) contains all rate calculations. The third section (ITASK = 3) is the state integration section and it contains all integration calculations. The fourth section (ITASK = 4) contains final calculations and statements that are made only once at the end of a simulation run (e.g., the writing of final crop yields to an output file).

The program structure of the simulation model ORYZA2000 in the FSE system is schematically illustrated in Figure 2.1. The main program ORYZA2000 calls the subroutine FSE. The subroutine FSE generates consecutively the four values of ITASK. The statement ITASK = 1 is generated only once at the beginning of simulation, and ITASK = 4 only once at the end of simulation. The statements ITASK = 2 and ITASK = 3 are repeated over and over again until the end of simulation. Each time an ITASK value is generated, the subroutine MODELS is called. MODELS is the interface to the actual simulation models, such as those of crop growth and the soil-water balance (Section 2.2). Because of the ITASK sequence generated by FSE, each simulation model called in MODELS will run synchronously, that is, each

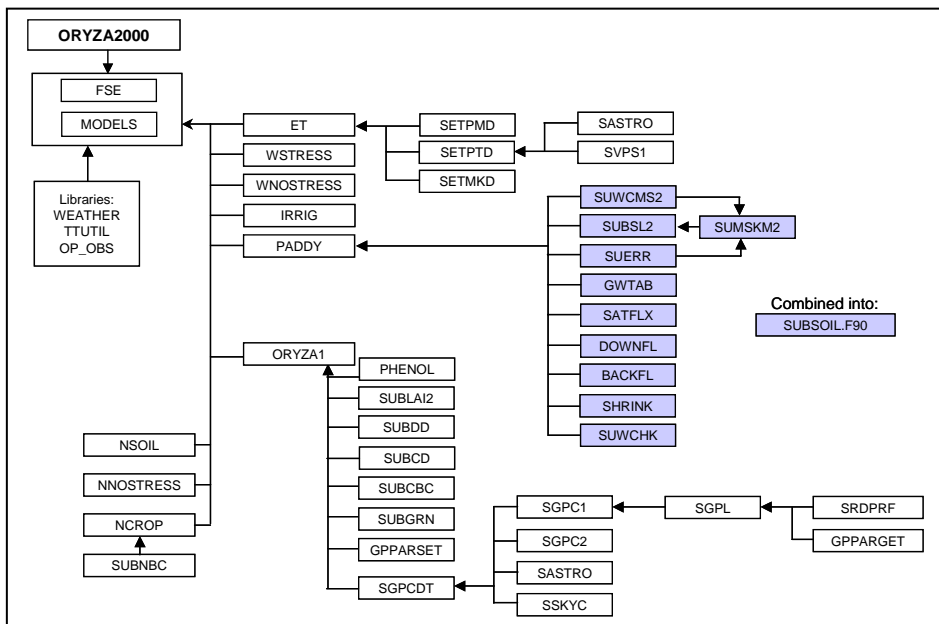

Fig. 2.1. Program and library structure of ORYZA2000 in the FSE system.

model performs rate calculations and state updates at exactly the same time step (i.e., day of year) using exactly the same weather variables for that particular time step. Calculated rate or state variables can be exchanged freely among the models.

Besides the generation of the ITASK values, the subroutine FSE performs several functions that make a simulation run smoothly. First, it performs several administrative tasks, such as the opening of input and output data files. It also calls three subroutines: TIMER2, STINFO, and WEATHR. The subroutine TIMER2 keeps track of the year and day number during the simulation at each time step in the model. It starts a simulation model at a date defined by STTIME, which is the starting day number, and IYEAR, which is the starting year of the simulation. In ORYZA2000, both STTIME and IYEAR are defined by the user in the experimental input data file (Section 7.2). During model running, the day of simulation is tracked in the variables DOY and IDOY, and the number of days gone by since starting the simulation in the variable TIME. DOY and IDOY are reset to day number 1 (1 January) when a simulation goes from one year to another, whereas TIME keeps counting the total number of days. The time step of integration (TIME, DOY, and IDOY update) is defined by the parameter DELT, which is user-defined in the experimental data file (Section 7.2). DELT should be set to 1 day in ORYZA2000.

The subroutines STINFO and WEATHR make up the weather library (van Kraalingen et al 1991) and assure that, at each day of simulation (time step), the correct daily weather data are retrieved from the file and passed to the models that need them (e.g., crop growth, water balance; see below). These subroutines also check the availability of the requested weather data and produce warning messages when errors occur in the data files. The weather routines automatically look for and open new weather data files when the time of simulation has reached the last day of a particular year of simulation. The subroutine TIMER2 then resets the day of simulation to 1 January of the next year (leap years are taken into consideration). At the end of simulation, the subroutine FSE closes all the input and output data files.

ORYZA2000 uses three so-called utility libraries. The library WEATHER contains the subroutines that read and process weather data from a file in a standard format defined by van Kraalingen et al (1991), and it is briefly explained in Sections 2.3 and 7.5. The library TTUTIL contains nonscientific (utility) functions and subroutines that ease operations such as data reading and writing and the integration and interpolation of variables. The library OP_OBS contains the so-called “observation system.” This system checks for the presence of observed values of a variable, and, if those values are present, retrieves these data and generates linearly interpolated daily values. Section 2.4 explains some of the most frequently used functions and subroutines in ORYZA2000.

2.2 The subroutine MODELS

The subroutines called in MODELS are the scientific simulation modules of ORYZA2000 (Fig. 2.1). They are briefly explained in the next section, whereas Chapters 3–6 give detailed descriptions.

2.2.1 The scientific simulation modules of ORYZA2000

MODELS calls the scientific subroutines in the following order:

- ET calculates potential evaporation rates of soil and water surfaces and potential transpiration rates of the crop. Users can select three calculation methods: Penman-Monteith (subroutine SETPMD), Priestley-Taylor (subroutine SETPTD), and Makkink (subroutine SETMKD) (Section 4.1).
- WSTRESS calculates actual transpiration and water uptake rates by the rice crop from the potential transpiration rates (calculated in ET) and from the soil-water tensions in the root zone (calculated in the soil-water balance model) (Section 4.2). Drought effect factors for specific growth and development processes of the rice crop are also calculated.
- WNSTRESS is called instead of WSTRESS under potential production situations when no soil-water balance is run (user-defined option) (Section 4.3). It sets the drought effect factors for growth and development of the rice crop at unity (no effect) and sets the actual transpiration rates at 0.
- ORYZA1 is the actual rice growth simulation model (Chapter 3). It calculates growth and development of rice as a function of daily weather data, crop characteristics, and management parameters. It takes into account drought stress effects calculated by WSTRESS (in water-limited situations) or by WNSTRESS (potential production) and nitrogen limitation effects calculated by NCROP (in nitrogen-limited situations) or by NNSTRESS (potential production).
- NCROP calculates potential nitrogen demand and actual nitrogen uptake of a rice crop, nitrogen distribution and translocation in the canopy, and stress effect factors for crop growth and development caused by nitrogen limitations (Section 5.1).
- NNSTRESS sets all stress effect factors for crop growth and development caused by nitrogen limitations at unity (no effect) (Section 5.3).
- NSOIL is a simple routine for tracking the daily nitrogen availability for crop uptake in the soil (Section 5.2).
- IRRIG calculates the daily irrigation water input for the soil-water balance as determined by user-defined management settings (Section 6.3).
- PADDY is a soil-water balance that calculates on a daily basis the soil water content and soil water potential (soil-water tension) (Section 6.2).

Which combination of the abovementioned subroutines is called is guided by two user-determined parameters as specified in the experimental data file (Section 7.2): PRODENV and NITROENV. The parameter PRODENV can have the value 'POTENTIAL', which indicates no water balance, and 'WATER BALANCE', which indicates the use of a water balance. The parameter NITROENV can have the values 'POTENTIAL', which indicates no nitrogen balance, and 'NITROGEN BALANCE', which indicates the use of a nitrogen balance. There are four possible combinations of subroutines:

1. PRODENV = 'POTENTIAL' and NITROENV = 'POTENTIAL'. No soil-water or crop nitrogen balances are run. The rice growth model ORYZA1 is called in combination with ET, WNOSTRESS, and NNOSTRESS.
2. PRODENV = 'WATER BALANCE' and NITROENV = 'POTENTIAL'. The rice growth model ORYZA1 is called in combination with ET, WSTRESS, IRRIG, PADDY, and NNOSTRESS.
3. PRODENV = 'POTENTIAL' and NITROENV = 'NITROGEN BALANCE'. The rice growth model ORYZA1 is called in combination with ET, NCROP, NSOIL, and WNOSTRESS.
4. PRODENV = 'WATER BALANCE' and NITROENV = 'NITROGEN BALANCE'. The rice growth model ORYZA1 is called in combination with ET, WSTRESS, IRRIG, PADDY, NCROP, and NSOIL.

Combination 1 is a true potential production situation in which water and nitrogen balances are not calculated. Combination 2 can be used to simulate water-limited production situations. However, when sufficient irrigation water is applied (via the subroutine IRRIG), there is no drought stress and ORYZA2000 simulates potential production as well. In this combination, the model calculates how much irrigation water is required to reach potential production. In combination 3, nitrogen-limited situations can be simulated. As with water, however, sufficient fertilizer nitrogen can be applied so that nitrogen does not limit crop growth. Combination 4 can be used to study situations in which both water and nitrogen may be limiting during (part of) the growing season. A strong warning, however, is in place for combination 4: whereas ORYZA2000 was extensively tested and validated for conditions of potential, water-limited, and nitrogen-limited production separately, it was not validated for conditions of combined water and nitrogen limitations. Despite this lack of validation, we chose to keep this combination in place so that users could test and (dis-)validate ORYZA2000 for this situation themselves and modify the model accordingly.

2.2.2 Subroutine MODELS: program statements

```
!-----!
! SUBROUTINE MODELS                                     !
! Author(s): Daniel van Kraalingen                     !
```

```

! Date      : 5-Jul-1993, Version: 1.1
! This version is used in the ORYZA2000 model; adapted by Bouman
! Date      : December 2001
! Purpose   : This subroutine is the interface routine between the FSE
!             driver and the simulation models. This routine is called
!             by the FSE driver at each new task at each time step. It
!             can be used to specify calls to the different
!             models that have to be simulated.
!
! FORMAL PARAMETERS:  I=input, O=output
! name  type meaning (unit)                                class
! ----  -
! ITASK  I4  Task that subroutine should perform (-)      I
! IUNITD I4  Unit number that is used for input files (-) I
! IUNITO I4  Unit number that is used for output file (-) I
! IUNITL I4  Unit number that is used for log file (-)    I
! FILEIT C*  Name of experimental file (-)                I
! FILEI1 C*  Name of input file no. 1 (-)                  I
! FILEI2 C*  Name of input file no. 2 (-)                  I
! FILEI3 C*  Name of input file no. 3 (-)                  I
! FILEI4 C*  Name of input file no. 4 (-)                  I
! FILEI5 C*  Name of input file no. 5 (-)                  I
! OUTPUT L4  Flag to indicate if output should be done (-) I
! TERMNL L4  Flag to indicate if simulation is to stop (-) I/O
! DOY    R4  Day number since 1 January (day of year) (d)  I
! IDOY   I4  Day number within year of simulation (d)      I
! YEAR   R4  Year of simulation (y)                        I
! IYEAR  I4  Year of simulation (y)                        I
! STTIME R4  Start day of simulation (d)                   I
! TIME   R4  Time of simulation (d)                       I
! DELT   R4  Time interval of integration (d)              I
! LAT    R4  Latitude of site (dec. degr.)                 I
! WSTAT  C*  Status code from weather system (-)          I
! WTRTER L4  Flag whether weather can be used by model (-) O
! RDD    R4  Daily short-wave radiation (kJ.m-2.d-1)       I
! TMMN   R4  Daily minimum temperature (degrees C)         I
! TMMX   R4  Daily maximum temperature (degrees C)        I
! VP     R4  Early morning vapor pressure (kPa)            I
! WN     R4  Average wind speed (m.s-1)                   I
! RAIN   R4  Daily amount of rainfall (mm.d-1)            I
!
! Subroutines called: ET, WSTRESS, WNOSTRESS, IRRIG, PADDY
!                    NSOIL, NNOSTRESS, NCROP, ORYZA1
! -----
SUBROUTINE MODELS (ITASK, IUNITD, IUNITO, IUNITL, &
                  FILEIT, FILEI1, FILEI2, FILEI3, FILEI4, FILEI5, &
                  OUTPUT, TERMNL, &

```

```

DOY      , IDOY      , YEAR      , IYEAR      , STTIME , &
TIME     , DELT     , LAT      , WSTAT    , WTRTER , &
RDD      , TMMN     , TMMX     , VP       , WN      , RAIN )

```

<Declaration of parameters>

```
DATA WUSED /'-----'/
```

The first part of the subroutine MODELS consists of the declaration of parameters. Then the string WUSED is filled with 6 hyphens '-----'. WUSED will be used later to check the availability of weather data. The six consecutive positions of the string of WUSED stand for the weather variables: (1) irradiation (RDD; $\text{kJ m}^{-2} \text{d}^{-1}$) or sunshine hours (h d^{-1}), (2) minimum temperature (TMMN; $^{\circ}\text{C}$), (3) maximum temperature (TMMX; $^{\circ}\text{C}$), (4) early morning vapor pressure (VP; kPa), (5) mean wind speed (WN; m s^{-1}), and (6) precipitation (RAIN; mm d^{-1}). A hyphen indicates that that particular variable is not requested. WUSED will be reset in accordance with the weather data requirements of the scientific subroutines (see below).

```

!=====
! Initialization section: ITASK = 1
!=====
      IF (ITASK.EQ.1) THEN

!-----Read data from the experimental data file
      CALL RDINIT (IUNITD, IUNITL, FILEIT)
      CALL RDSCHA ('RUNMODE' , RUNMODE)
      CALL RDSCHA ('ESTAB'   , ESTAB )

      .....

```

In the model-initialization section (defined by $\text{ITASK} = 1$), model parameters are read from files and the initial conditions of the simulation are set. The reading of input parameters is done with utility routines from the library TTUTIL (Section 2.4). In the example above, the RDINIT call opens the experimental data file defined under the file name FILEIT and prepares it for data reading. Next, the parameters RUNMODE (production mode) and ESTAB (establishment type) are read. The name of the experimental data file is defined in the ORYZA2000 control file CONTROL.DAT (Section 7.1).

```

!-----Initialize variables
      CROPSTA = 0
      WLO     = 0.
      RAINCU  = 0.
      TRWCU   = 0.
      DO I=1,NLXM
          WCLQT(I) = 0.3
          WCST(I)  = 0.3
      END DO

```

After the program reads model parameters from the data files, some variables get an initial value. The crop stage (CROPSTA), the initial depth of ponded water (WL0; mm), and the sums of rainfall (RAINCU; mm) and actual crop transpiration (TRWCU; mm) are set at 0. The values of standing water depth (WL0; mm), soil water content (WCLQT; $\text{m}^3 \text{m}^{-3}$), and saturated soil water content (WCST; $\text{m}^3 \text{m}^{-3}$) are given fictive values to avoid initialization errors in the potential evapotranspiration routine ET.

```
!-----Write and check info on water production situation setting
      IF (PRODENV.EQ.'POTENTIAL') THEN
        WRITE (IUNITO,'(A,T7,A)') &
          '*','Rice grown in potential water production situation'
      ELSE IF (PRODENV.EQ.'WATER BALANCE') THEN
        WRITE (IUNITO,'(A,T7,A)') &
          '*','Soil water balance used'
        WUSED(6:6) = 'U'
      ELSE
        CALL FATALERR &
          ('MODELS','unknown name for production situation')
      END IF
```

Information on the production situation that is being simulated is checked for consistency and written to the output file. In the example above, the production situation with respect to water (PRODENV) is checked. The selected water production situation should be either POTENTIAL or WATER-LIMITED. If something else is found in the data file, the subroutine FATALERR is called (Section 2.4.2) and the simulation is aborted with an informative message sent to the screen. When the model is run with a water balance, rainfall is needed as an input variable (Section 6.2). To indicate this, the letter U is assigned to the sixth position of the string WUSED.

```
!-----Choose and check nitrogen production situation setting
      .....

!-----Send warning if water and nitrogen limitations are combined
      IF (NITROENV.EQ.'NITROGEN BALANCE' .AND. &
        PRODENV.EQ.'WATER BALANCE') THEN
        WRITE (IUNITO,'(A,T7,A)') &
          '*','*****'
        WRITE (IUNITO,'(A,T7,A)') &
          '*','WARNING: Combined water and nitrogen limitations not validated!!'
        WRITE (IUNITO,'(A,T7,A)') &
          '*','*****'
      END IF
```

In the same way, information on the nitrogen production situation (NITROENV) is checked and written to the output file. A warning is sent to the

output file when the production situation is both water-limited (PRODENV.EQ.'WATER BALANCE') and nitrogen-limited (NITROENV.EQ.'NITROGEN BALANCE'). Whereas ORYZA2000 was extensively tested and validated for conditions of potential, water-limited, and nitrogen-limited production separately (Section 8.3), it was not validated for conditions of combined water and nitrogen limitations.

```
!-----Write information about RUNMODE to output file
.....
!-----Choose and check establishment setting
.....

!-----Choose and check evapotranspiration modules
IF (ETMOD.EQ.'PENMAN') THEN
  WRITE (IUNITO,'(A,T7,A)') &
    '*','SETPMD: Penman evapotranspiration'
  WUSED(1:5) = 'UUUUU'
ELSE IF (ETMOD.EQ.'MAKKINK') THEN
  WRITE (IUNITO,'(A,T7,A)') &
    '*','SETMKD: Makkink evapotranspiration'
  WUSED(1:3) = 'UUU'
ELSE IF (ETMOD.EQ.'PRIESTLEY TAYLOR') THEN
  WRITE (IUNITO,'(A,T7,A)') &
    '*','SETPTD: Priestley Taylor evapotranspiration'
  WUSED(1:3) = 'UUU'
ELSE
  CALL FATALERR &
    ('MODELS','unknown module name for evapotranspiration')
END IF
```

After checking the nitrogen production situation, information on the mode of simulation (RUNMODE, either the simulation of a particular experiment or the simulation of an exploration run), the manner of crop establishment (ESTAB), and the selected procedure for the calculation of evapotranspiration (ETMOD) is checked and written to the output file. The Penman equations require all weather variables except rainfall, so a U is assigned to the first five positions of WUSED. The Makkink and Priestley-Taylor routines require only radiation and minimum and maximum temperature, so a U is assigned only to the first three positions.

```
!-----Check weather data for ORYZA1 crop model
  WUSED(1:3) = 'UUU'
```

For the crop growth model ORYZA1, the presence of radiation and minimum and maximum temperature is required and a U is assigned to the first three positions of WUSED.

```

!-----Write log messages to output file
      WRITE (IUNITO,'(A,76A1)') '*',( '=',I1=1,76)
      WRITE (IUNITO,'(A)') '* '
      WRITE (IUNITO,'(A)') '* FSE driver info:'
      WRITE (IUNITO,'(A,T7,A,I5,A,I4,A)') &
        '*','Year:',IYEAR,' ', day:',IDOY,', ' System start'

      END IF

!=====
! Here ended initialization section ITASK = 1
!=====

```

Then, some final information on the year and start day of simulation is written to the output file and the initialization section (ITASK.EQ.1) ends.

```

!-----Check weather data availability
      IF (ITASK.EQ.1.OR.ITASK.EQ.2.OR.ITASK.EQ.4) THEN
        IF (WSTAT(6:6).EQ.'4') THEN
          RAIN = 0.
          WSTAT(6:6) = '1'
          IF (.NOT.GIVEN) THEN
            WRITE (IUNITL,'(2A)') ' Rain not available,', &
              ' value set to zero, (patch DvK, Jan 1995)'
            GIVEN = .TRUE.
          END IF
        END IF
      END IF

!-----Check whether there is an error in the I1th weather variable
      DO I1=1,6
        IF (WUSED(I1:I1).EQ.'U' .AND. &
          WSTAT(I1:I1).EQ.'4') THEN
          WTRTER = .TRUE.
          TERMNL = .TRUE.
          RETURN
        END IF
      END DO
    END IF

```

After initialization, the presence of the requested weather data is checked at each rate calculation step (ITASK.EQ.2) and at the start (ITASK.EQ.1) and end (ITASK.EQ.4) of each simulation run. The weather data are read from the data file by the WEATHER system in FSE and passed to the subroutine MODELS (Section 2.3). When a weather variable at a specific date is not present, the WEATHER system assigns the value 4 at the relevant position of a six-position string WSTAT. Thus, if no rainfall data are present in the weather data file on a particular day, this is indicated by the value 4 on position 6. To make sure that the simulation subroutines that require rainfall (i.e., the soil-water balance model PADDY) still have input, it is assumed that rainfall on

that particular day was 0. Therefore, the amount of rainfall (RAIN; mm d⁻¹) is set at 0 and the value 1 is assigned to the sixth position of WSTAT, indicating that rainfall is now available. For all other weather variables, missing data are handled in the WEATHER system. If possible, missing values are interpolated and a warning message is generated by the subroutine WEATHR and sent to the screen and the weather log report. After the rainfall data patch, the requested weather data, as indicated by the status of WUSED, are checked against the availability of the weather data, as indicated by the status of WSTAT. If any requested variable is missing, the logical variable TERMNL is set at .TRUE. and the FSE system aborts the simulation. The logical WTRTER registers the absence of the weather data and prepares error messages.

```
!-----Calculate average temperature
      TMDA = (TMMX+TMMN)/2.
```

After checking the weather data, the mean daily temperature (TMDA; °C) is calculated from the maximum and minimum air temperature. This information is needed in the evapotranspiration subroutine ET.

```
!-----Calculate potential soil evaporation and transpiration
      CALL ET(ITASK,ANGA, ANGB, RDD, TMDA, VP, WN, LAT, &
             IDOY, ETMOD, CROPSTA, NL, FAOF, WL0, &
             WCLQT, WCST, LAI, EVSC, ETD, TRC)
```

```
!-----Calculate drought stress factors
      IF (PRODENV.EQ.'WATER BALANCE') THEN
          CALL WSTRESS (ITASK, DELT, OUTPUT, IUNITD, IUNITL, FILEI1, &
                      TRC, ZRT, TKL, NL, CROPSTA, &
                      WCLQT, WCWP, MSKPA, &
                      TRW, TRWL, LRSTRS, LDSTRS, LESTRS, PCEW)
      ELSE IF (PRODENV.EQ.'POTENTIAL') THEN
          CALL WNSTRESS(NL,TRW, TRWL,LRSTRS, LDSTRS, LESTRS, PCEW)
      END IF
```

```
!-----Call the crop growth module
      CALL ORYZA1(ITASK, IUNITD, IUNITL, FILEI1, FILEIT, &
                 OUTPUT, TERMNL, IDOY, DOY, &
                 TIME, DELT, LAT, RDD, TMMN, TMMX, &
                 NFLV, NSLLV, RNSTRS, &
                 ESTAB, TKLT, ZRTMS, CROPSTA, &
                 LRSTRS, LDSTRS, LESTRS, PCEW, &
                 DAE, LAI, LAIROL, ZRT, DVS, &
                 LLV, DLDR, WLVG, WST, WSO, GSO, GGR, GST, GLV,&
                 PLTR)
```

```
!-----Call the nitrogen crop demand and soil supply modules
      IF (NITROENV.EQ.'NITROGEN BALANCE') THEN
```

```

CALL NCROP(ITASK,IUNITD, IUNITL, FILEI1, DELT, TIME, OUTPUT, &
          TERMNL,DVS,LLV,DLDR,WLVG,WST,WSO,GSO,GST,GLV,&
          PLTR,LAI,CROPSTA, TNSOIL, NACR, NFLV, NSLLV,RNSTRS)
CALL NSOIL(ITASK, IUNITD, IUNITL, FILEIT, OUTPUT, DELT, DAE, &
          DVS, NACR, TNSOIL)
ELSE IF (NITROENV.EQ.'POTENTIAL') THEN
  CALL NNOSTRESS(DELT, IUNITD, IUNITL, ITASK, FILEI1, FILEIT, &
              CROPSTA, DVS, NFLV, NSLLV, RNSTRS)
END IF

!-----Call the water balance module
IF (PRODENV.EQ.'WATER BALANCE') THEN
!-- First, the irrigation subroutine
CALL IRRIG (ITASK, IUNITD, IUNITL, FILEIT, OUTPUT, &
          DOY, DELT, CROPSTA, WLO, &
          NL, WCLQT, MSKPA, IR)
! Then the soil-water balance module
CALL PADDY (ITASK, IUNITD, IUNITL, FILEI2, OUTPUT, &
          DOY, DELT, TIME, CROPSTA, ESTAB, &
          RAIN, EVSC, TRWL, TRW, IR, &
          NL, ZRTMS, TKL, TKLT, &
          WCAD, WCWP, WCFC, WCST, WCLQT, &
          WLO, MSKPA)
!-- No water balance in potential situation
ELSE IF (PRODENV.EQ.'POTENTIAL') THEN
  TKLT = 100.
  ZRTMS = 100.
  WLO=0.
  NL = NLXM
  DO I=1,NL
    WCLQT(I) = 0.3
    WCST(I) = 0.3
  END DO
END IF

```

After checking the weather data, the scientific subroutines that make up ORYZA2000 are called. The selection of these routines is guided by the settings of the production environments that were read and checked in the initialization section of the model (Section 2.2.1). Only two modules are always executed: ET for potential evapotranspiration and ORYZA1 for crop growth and development. If no soil-water balance is run, some variables are given a hypothetical value to ensure the correct functioning of the potential evapotranspiration routine ET and the crop growth model ORYZA1. The value of standing water depth (WLO; mm) is set at 0 and the current soil water content (WCLQT; $\text{m}^3 \text{m}^{-3}$) and saturated soil water content (WCST; $\text{m}^3 \text{m}^{-3}$) are given a fictive value of 0.3. In this way, the potential evaporation rate

calculated in ET is that of a saturated soil with no standing water (Section 4.1). The values for maximum root depth (ZRTM; m) and total depth of the soil profile (TKLT; m) are set at 100 m so that no soil impediments restrict root growth.

```

!=====
! Output writing only at ITASK = 2
!=====
      IF (ITASK.EQ.2) THEN
        IF (OUTPUT) THEN
          CALL OUTDAT (2, 0, 'YEAR', YEAR)
          CALL OUTDAT (2, 0, 'DOY', DOY)
          CALL OUTDAT (2, 0, 'CROPSTA ', REAL (CROPSTA))
          CALL OUTDAT (2, 0, 'TRC', TRC)
          CALL OUTDAT (2, 0, 'EVSC', EVSC)
          CALL OUTDAT (2, 0, 'TRW', TRW)
          CALL OUTDAT (2, 0, 'RAIN', RAIN)
          CALL OUTDAT (2, 0, 'RAINCU', RAINCU)
          CALL OUTDAT (2, 0, 'TRWCU', TRWCU)
        END IF
      END IF

```

At each rate calculation (ITASK.EQ.2), output is written to the output data file using subroutine OUTDAT of the WEATHER system (Section 2.4). Output is written only when the logical OUTPUT is .TRUE. The value of OUTPUT is set in the subroutine FSE and is guided by the user through the setting of the PRDEL parameter in the input file CONTROL.DAT (Section 7.1). PRDEL defines the interval in days between writing output values to the data file. The variables sent to the output file here are year (YEAR; y) and day number of simulation (DOY; d), crop stage (CROPSTA; -), reference evapotranspiration (ETD; mm d⁻¹), potential transpiration by the crop (TRC; mm d⁻¹), potential soil evaporation (EVSC; mm d⁻¹), actual transpiration by the crop (TRW; mm d⁻¹), daily rainfall (RAIN; mm d⁻¹), cumulative amount of rainfall since the start of the simulation (RAINCU; mm), and cumulative amount of actual crop transpiration since the start of the simulation (TRWCU; mm). The evapotranspiration variables are all calculated in ET and passed to MODELS.

```

      IF (ITASK.EQ.1 .OR. ITASK.EQ.3) THEN
        IF (CROPSTA .EQ. 3) CROPSTA = 4
        IF (CROPSTA .EQ. 2) THEN
          IF (DAE .EQ. REAL(SBDUR)) CROPSTA = 3
        END IF
        IF (CROPSTA .EQ. 1) THEN
          IF (ESTAB.EQ. 'TRANSPLANT') THEN
            CROPSTA = 2
          END IF
        END IF
      END IF

```

```

ELSE IF (ESTAB.EQ.'DIRECT-SEED') THEN
  CROPSTA = 4
END IF
END IF
IF (CROPSTA .EQ. 0) THEN
  IDATE = DTFSECMP(EMYR, EMD, IYEAR, IDOY)
  IF (IDATE .EQ. 0) THEN
    CROPSTA = 1
  ELSE IF (IDATE .EQ. 1) THEN
    CALL FATALERR ('MODELS', &
      'Time past supplied sowing date or year')
  END IF
END IF
END IF

```

MODELS keeps track of the main stages of a crop cycle in the variable CROPSTA. The value of CROPSTA determines certain calculation options in the model ORYZA1 (Chapter 3) and determines the start/initialization of other subroutines such as NSOIL and NCROP. Four stages are defined: 0 = before emergence (i.e., bare soil conditions), 1 = emergence of the crop in the seedbed for transplanted crops or in the main field for direct-seeded crops, 2 = period in the seedbed (only for transplanted crops), 3 = transplanting (only for transplanted crops), and 4 = period in the main field (which starts directly after transplanting for transplanted crops or after emergence in the main field for direct-seeded crops). The method of crop establishment is defined by the parameter ESTAB, which was read from the experimental data file (Section 7.2) in the initialization section of MODELS. CROPSTA was initialized at 0 at the start of the simulation during initialization. Except for the soil-water balance model, all subroutines skip calculations when CROPSTA equals 0. CROPSTA retains the value 0 with each time step of simulation until emergence is reached. The date of emergence is defined by the year of emergence (EMYR) and the day of emergence (EMD), which were read from the experimental data file during initialization. The function DTFSECMP returns the value 0 when the date of simulation, defined by year of simulation (IYEAR) and day of simulation (IDOY), equals the date of emergence. When the simulation starts with a date that is already past the emergence date, DTFSECMP returns the value 1. The return value of DTFSECMP is stored in the temporary variable IDATE. When IDATE = 0, crop growth starts and CROPSTA assumes the value of 1. In the next time step (day), CROPSTA is 2 for transplanted rice and 4 for direct-seeded rice. A counter tracks the number of days gone by since emergence (DAE; d) at each time step in the model ORYZA1, and its value is passed back to MODELS. When DAE equals the number of days that the crop spends in the seedbed for transplanted rice (SBDUR, d; read from the experimental data file during initialization), CROPSTA is 3 and transplanting occurs. In the next time step (day), the main growth period starts and CROPSTA is 4. When IDATE = 1, the model stops and returns an error

message to the screen and the log file MODEL.LOG using the subroutine FATALERR (Section 2.4.2).

```
!-----Summation of some state variables
      RAINCU = RAINCU + RAIN
      TRWCU  = TRWCU + TRW
```

The cumulative amount of rainfall (RAINCU; mm) and actual crop transpiration (TRWCU; mm) since the start of the simulation are calculated.

```
!=====
! Terminal calculations at ITASK = 4
!=====
      IF (ITASK.EQ.4) THEN
!       WRITE (IUNITO,'(A)') '*'
!       WRITE (IUNITO,'(A)') '* FSE driver info:'
      WRITE (IUNITO,'(A,T7,A,I5,A,I4,A)') &
        '*','Year:',IYEAR,' day:',IDOY,' System end'
!--- Terminal output
      CALL OPSTOR ('SBDUR', 1.*SBDUR)
      CALL OPSTOR ('DAE', DAE)
      CALL OPSTOR ('RAINCU', RAINCU)
      CALL OPSTOR ('TRWCU', TRWCU)
      END IF
!=====
! End of section ITASK = 4
!=====
      RETURN
      END
```

After all the modules have been called and necessary calculations performed, the statements for the terminal section at the end of a simulation run are given (ITASK.EQ.4). Final information on the year and end day of simulation is written to the output file, and end-of-simulation values of some variables are written to a separate output file using the subroutine OPSTOR (Section 2.4.2). These variables are the days that the crop spent in the seedbed (SBDUR; d), crop duration since emergence (DAE; d), cumulative amount of rainfall since the start of the simulation (RAINCU; mm), and cumulative amount of actual crop transpiration since the start of the simulation (TRWCU; mm).

2.3 The WEATHER system

Van Kraalingen et al (1991) give a detailed description of the WEATHER system, which is included on the CD-ROM accompanying this book. This

Section gives a summary description with special reference to the implementation in ORYZA2000.

The library WEATHER is composed of the subroutines STINFO and WEATHR. Together, they assure that at each day of simulation (time step of integration), the correct daily weather data are retrieved from the file, checked for consistency, and passed to the simulation models called in the subroutine MODELS under the FSE system.

STINFO requires user-specified variables that define the station from which the weather data were obtained: country name, station and year number, location parameters, and (optionally) Ångström parameters. It passes some of this information to the subroutines WEATHR and MODELS, and writes station information and possible error or warning messages to a log report (WEATHER.LOG). The name of the country and the number of the station and year define the data file from which weather data are to be read. This information is user-defined in the experimental data file (Section 7.2; see also Section 7.5).

The subroutine WEATHR extracts the following data from the weather data file: year and station number, daily values for irradiation (RDD; $\text{kJ m}^{-2} \text{d}^{-1}$) or sunshine hours (h d^{-1}), minimum temperature (TMMN; $^{\circ}\text{C}$), maximum temperature (TMMX; $^{\circ}\text{C}$), early morning vapor pressure (VP; kPa), mean wind speed (WN; m s^{-1}), and precipitation (RAIN; mm d^{-1}). The format of the weather data file is very strict and is described in detail in Section 7.5. Besides the weather variables, the weather data file also contains information on longitude (LONG; decimal degree), latitude (LAT; decimal degree), and elevation (ELEV; m) of the weather station. This information is passed on to MODELS and part of it is used, for instance, in the photosynthesis subroutines of the crop growth model ORYZA1 (Section 3.2.2) and the Penman evapotranspiration subroutine called in ET (Section 4.1). The daily weather data are passed to MODELS and are used by the crop growth model ORYZA1, the evapotranspiration subroutines, and the soil-water balance module. The photosynthesis subroutines of ORYZA1 require (besides temperature) solar radiation values in $\text{kJ m}^{-2} \text{d}^{-1}$. However, many meteorological observation stations record daily sunshine hours instead of radiation. Sunshine hours can be entered in the weather data file instead of radiation values, and these are automatically converted into radiation values by the WEATHER system if the so-called Ångström parameters (ANGA, ANGB) are given in the data file (see Section 7.5 for the format). Sunshine hours are transformed into radiation (S_g ; $\text{kJ m}^{-2} \text{d}^{-1}$) using the Ångström formula:

$$S_g = S_0 \times (a_A + b_A \times (n_s/N_s)) \quad (2.1)$$

where S_0 is the theoretical amount of global radiation without an atmosphere ($\text{kJ m}^{-2} \text{d}^{-1}$), a_A is an empirical constant, the so-called Ångström A parameter (-; see Table 2.1), b_A is an empirical constant, the so-called Ångström B

Table 2.1. Indicative values for the empirical constants a_A and b_A in the Ångström formula, in relation to latitude used by the Food and Agriculture Organization (FAO).

Zones	a_A	b_A
Cold and temperate	0.18	0.55
Dry tropical	0.25	0.45
Humid tropical	0.29	0.45

Source: Frère and Popov (1979).

parameter (-; see Table 2.1), and n_s/N_s is the ratio between the amount of bright sunshine hours (n_s) and the maximum amount of sunshine hours (N_s) (-).

The value of S_0 is derived from the location parameters of the station and the year and day number. If daily radiation data are given in the weather data file, 0 values should be given for the Ångström A (ANGA) and B (ANGB) parameters. The WEATHER system then “recognizes” that no sunshine to radiation conversion needs to be done.

The WEATHER system checks the consistency of the weather data and sends warning or error messages to the screen and to a log file (WEATHER.LOG) when errors or suspect data are found in the data files. The system also looks for and opens subsequent weather data files when the simulation has reached the last day of the year.

2.4 Utility functions and subroutines

Several utility functions and subroutines are called in ORYZA2000 that make up part of the libraries TTUTIL and OP_OBS. Van Kraalingen and Rappoldt (2000) give a detailed description of TTUTIL, which is included on the CD-ROM accompanying this book. The library OP_OBS contains the so-called “observation system,” which checks for the presence of observed values of any given variable, and, if they are present, retrieves these data and obtains linearly interpolated daily values. It also contains routines that write simulation results at the end of a simulation to a predefined output file called OP.DAT (Section 7.7). The library OP_OBS is not documented but the main functions are described below and throughout the chapters of this book where necessary. Here, we briefly explain some of the most commonly used functions and subroutines of TTUTIL and OP_OBS in ORYZA2000.

2.4.1 Functions

REAL FUNCTION GETOBS (FILEIN, XNAME). Returns the estimated (through interpolation) observation from data file FILEIN for variable

XNAME. The observed values in the data file should be listed under XNAME_OBS, which consists of three columns: year number, day number, and variable value. The interpolation is based on the day number of the simulation.

LOGICAL FUNCTION INQOBS (FILEIN, XNAME). Queries the observation system (OP_OBS) about the presence of observation data of the variable XNAME in the data file FILEIN on the day of simulation. It returns .TRUE. or .FALSE. The observed values in the data file should be listed under XNAME_OBS and consist of three columns: year number, day number, and variable value.

REAL FUNCTION INTGRL (STATE, RATE, DELT). Integrates the variable STATE with its rate variable RATE over time DELT.

REAL FUNCTION INTGR2 (STATE, RATE, DELT, FILEIN, 'STATE'). The same as INTGRL, but with the additional functionality that the simulated state variable can be “overruled” by observed values of STATE read from an input data file defined by FILEIN. A detailed example of the use of INTGR2 for the integration of leaf area index (LAI) in the model ORYZA1 appears in Sections 3.3 and 7.2.

REAL FUNCTION LIMIT (MIN, MAX, X). Returns the value of X limited within the boundaries MIN and MAX.

REAL FUNCTION LINT (TABLE, ILTAB, X). This function performs a linear interpolation between values of an ‘X,Y’ table (array), using X as the entry. ILTAB defines the length of the array TABLE. The function also extrapolates outside the defined region in case X is below or above the region defined by TABLE.

REAL FUNCTION LINT2 (TABLE, ILTAB, X). The same as LINT, but with better warning messages when values are extrapolated.

REAL FUNCTION NOTNUL (X). This function can be used to avoid “divide by zero” errors in division. The function result is defined as NOTNUL = X if X is not 0 and NOTNUL = 1 when X is 0.

2.4.2 Subroutines

SUBROUTINE FATALERR (STRING1, STRING2). Writes the error messages STRING1 and STRING2 to the screen and holds the simulation until <RETURN> is pressed. Then the execution of the model is terminated.

Subroutines for reading data

ORYZA2000 uses several external data files to read data from. These data files are user-defined in the file CONTROL.DAT:

- FILEI1, used for the crop data file (e.g., FILEI1 = ‘IR72.DAT’);
- FILEI2, used for the soil data file;

- FILEIT used for experimental data.

Section 7.1 contains detailed information on input data files.

SUBROUTINE RDINIT (IUNIT, IULOG, DATFIL). Initializes a data file reading with the routines RDSINT, RDSREA, RDSCHA, and RDAREA. IUNIT is the number used to open the random access file, IULOG is the number of the log file used for data file syntax errors, and DATFIL is the name of the data file from which data are to be read.

SUBROUTINE RDSINT (XNAME, IX). Reads a single INTEGER variable from a data file. XNAME is the name of the variable and IX is the value of that variable.

SUBROUTINE RDSREA (XNAME, IX). Reads a single REAL variable from a data file. XNAME is the name of the variable and IX is the value of that variable.

SUBROUTINE RDSCHA (XNAME, IX). Reads a single CHARACTER string value from a data file. XNAME is the name of the variable and IX is the value of that variable.

SUBROUTINE RDAREA (XNAME, X, ILDEC, IFDN). Reads an array of REAL values from a data file. The length of the array does not have to be specified exactly, only a maximum size needs to be supplied. XNAME is the name of the array, X represents the values of that array, ILDEC is the declared maximum length of the array, and IFND is the number of values found (i.e., the actual size of the area).

Subroutines for writing data

ORYZA2000 produces two data output files. The name of the first is user-defined by the variable name FILEON in CONTROL.DAT (e.g., FILEON = 'RES.DAT'; Sections 7.1 and 7.7). This file is used to store output variable values during the simulation. The second is a fixed file name called OP.DAT, which stores only end-of-simulation results (Section 7.7).

SUBROUTINE OUTDAT (IT, IUNIT, XNAME, XVALUE). Can be used to write the value XVALUE of the variable XNAME to a user-defined output file during the simulation. An output file should be initialized first with a call OUTDAT, where the value of IT is 1. For regular output writing afterward, IT should be 2 and calls to OUTDAT should be made at the end of the rate calculation section of a program (when ITASK.EQ.2). IUNIT is the number used for writing to the output file. In ORYZA2000, IUNIT = 0. The output file is defined in CONTROL.DAT by the variable name FILEON (usually RES.DAT; Section 7.1).

SUBROUTINE OPSTOR (XNAME, XVALUE). Can be used to write the end-of-simulation value XVALUE of the variable XNAME to a specific

output file named OP.DAT. Calls to OPSTOR should be made at the terminal calculation section of a program (when ITASK.EQ.4).

Unit numbers and file names

In the subroutine FSE of ORYZA2000, the following values for unit numbers (for file access, see FORTRAN manuals for the meaning of unit numbers, e.g., Wagener 1980) and file names are set and passed to MODELS:

IUNITD	Unit number that is used for input files (2X)
IUNITO	Unit number that is used for output file (3X)
IUNITL	Unit number that is used for log file (4X)
FILEIT	Name of experimental data file (defined in CONTROL.DAT)
FILEIR	Name of reruns data file (defined in CONTROL.DAT)
FILEI1	Name of crop data input file (defined in CONTROL.DAT)
FILEI2	Name of soil data input file (defined in CONTROL.DAT)
FILEON	Name of dynamic output data file (defined in CONTROL.DAT)
FILEOL	Name of log report (defined in CONTROL.DAT)

3 Crop growth and development

The growth and development of rice are simulated with the model ORYZA1. Figure 3.1 shows the general structure of the model. Under conditions of potential production, light, temperature, and varietal characteristics for phenological, morphological, and physiological processes determine the growth of the crop (Fig. 3.1A). The model follows the daily calculation scheme for the rates of dry matter production of the plant organs and the rate of phenological development. By integrating these rates over time, dry matter production of the crop is simulated throughout the growing season.

The total daily rate of canopy CO_2 assimilation is calculated from the daily incoming radiation, temperature, and leaf area index. The model contains a set of subroutines that calculate the daily rate by integrating instantaneous rates of leaf CO_2 assimilation over time and depth within the canopy. The calculation is based on an assumed sinusoidal time course of radiation over the day and the exponential light profile within the canopy. On the basis of the photosynthesis characteristics of single leaves, which depend on the N concentration, the photosynthesis profile in the canopy is obtained. Integration over the leaf area index of the canopy and over the day gives the daily CO_2 assimilation rate. After subtraction of respiration requirements, the net daily growth rate in kg

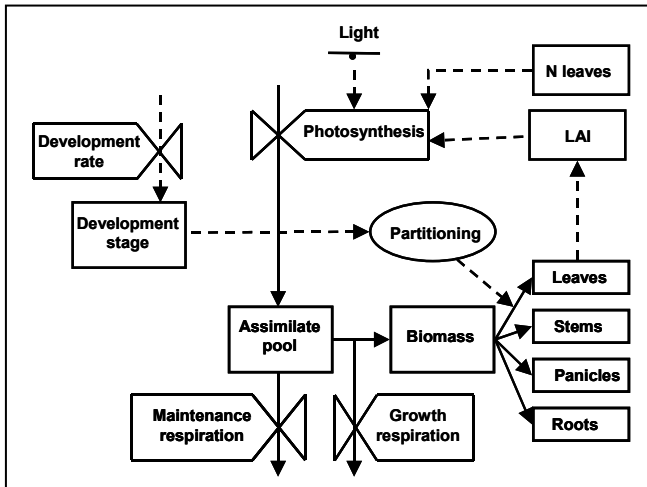

Fig. 3.1A. A schematic representation of the model ORYZA1 in the situation of potential production. Boxes are state variables, valves are rate variables, and circles are intermediate variables. Solid lines are flows of material and dotted lines are flows of information.

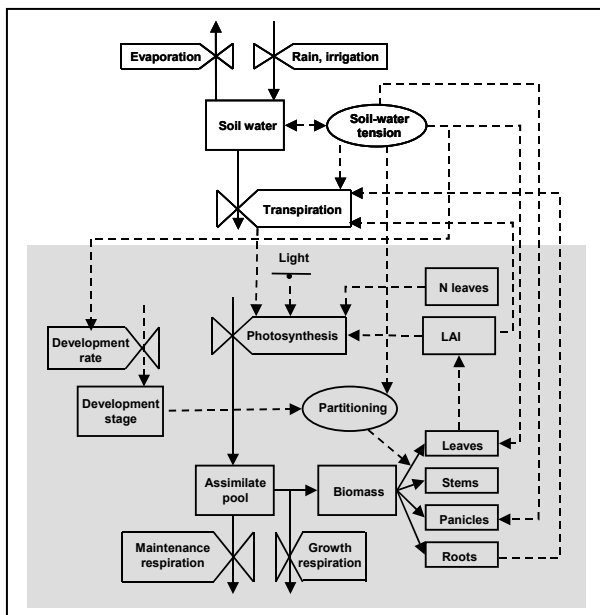

Fig. 3.1B. For the situation of water-limited production, ORYZA1 (gray area) and its links to the water balance sub-routines.

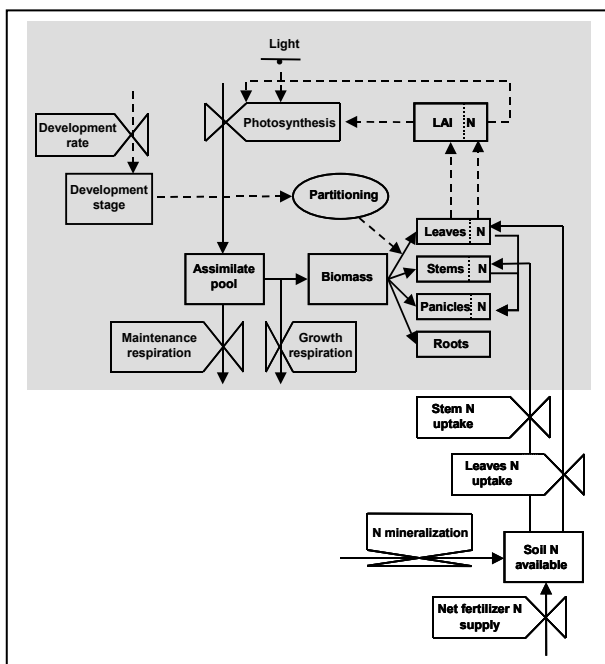

Fig. 3.1C. For the situation of nitrogen-limited production, ORYZA1 (gray area) and its links to the nitrogen balance sub-routines.

dry matter per ha per day is obtained. The dry matter produced is partitioned among the various plant organs.

The phenological development rate is tracked as a function of daily average ambient temperature and photoperiod. When the canopy is not yet closed, leaf area increment is calculated from daily average temperature because carbohydrate production does not limit leaf expansion. When the canopy closes, the increase in leaf area is obtained from the increase in leaf weight. Integration of daily growth rates of the organs and leaf area results in dry weight increment during the growing season. The time step of integration is one day. A simple procedure is used to simulate sink limitation as a result of spikelet sterility at high or low temperatures.

Under conditions of water-limited production, the growth and development of the crop are affected by drought. In ORYZA1, the following effects of drought are taken into account: leaf rolling, spikelet sterility, reduced leaf expansion rate, changed assimilate partitioning, increased root depth, delayed vegetative development, increased leaf senescence, and decreased photosynthesis rate (through decreased transpiration rate) (Fig 3.1B). For each of these processes, so-called drought stress factors are calculated in WSTRESS (Section 4.2) and passed on to the growth model ORYZA1. The drought stress factors are calculated from the soil-water tension simulated with the soil-water balance model PADDY (Section 6.2).

Under conditions of nitrogen-limited production, the growth and development of the crop are affected by a lack of nitrogen. In ORYZA1, we simulate the effect of leaf N content on photosynthesis and on the relative growth rate of leaves, and the effect of the amount of N in the crop on the leaf death rate (Fig. 3.1C). The leaf N content and the factor quantifying the effect of crop N status on the relative leaf growth rate are calculated in NCROP (Section 5.1) and passed on to ORYZA1. The soil N balance is calculated with NCROP (Section 5.2).

The model ORYZA1 is called from the subroutine MODELS of ORYZA2000 (Section 2.2) and is divided into sections for initialization, rate calculations, state integrations, and terminal calculations. In the initialization section, all model state and rate variables are given an initial value and model parameters are read from data files. Crop data are read from an external crop file (Section 7.3) and management parameters from the experimental data file (Section 7.2). Except for specific conditions, this initialization section is not further detailed.

3.1 Initial conditions

```
SUBROUTINE ORYZA1(ITASK, IUNITD, IUNITL, FILEI1, FILEIT, &
                  OUTPUT, TERMNL, IDOY, DOY, &
                  TIME, DELT, LAT, RDD, TMMN, TMMX, &
                  NFLV, NSLLV, RNSTRS, &
```

```

ESTAB, TKLT, ZRTMS, CROPSTA, &
LRSTRS, LDSTRS, LESTRS, PCEW, &
DAE, LAI, LAIROL, ZRT, DVS, &
LLV, DLDR, WLVG, WST, WSO, GSO, GGR, GST, GLV,&
PLTR)

```

<Declaration of parameters>

```

!=====*
!      Initialization section                                *
!=====*
!-----Initialization
      IF (ITASK.EQ.1) THEN
!      Initialize variables

      CALL RDSREA('LAPE ',LAPE )
      CALL RDSREA('DVSI ',DVSI )
      .....
      CALL RDAREA('SLATB ',SLATB ,IMX,ILSLAT)
      DVS      = 0.
      .....
      WSO      = 0.
      .....
      WRT      = 0.
      .....
      ZRT      = 0.
      .....

```

In ORYZA1's initialization section (defined by ITASK = 1), model parameters are read from the file and the initial conditions of the simulation are set. The reading of input parameters is done with utility routines from the library TTUTIL (Section 2.4.2). The initial development stage, rooting depth, leaf area, and weights of the leaves, stems, storage organs, and roots are set at 0. Other state variables such as temperature sums are also set at 0.

```

!=====*
!      Rate calculation section                                *
!=====*
      ELSE IF (ITASK.EQ.2) THEN

!-----Reinitialize weights and LAI at day of emergence
      IF (CROPSTA .EQ. 1) THEN
          DVS = DVSI
          WLVG = WLVG1
          WLVD = 0.
          WSTS = WSTI
          WSTR = 0.
          WST = WSTS+WSTR
          WSO = WSOI

```

```

WRT = WRTI
ZRT = ZRTI
IF (ESTAB.EQ. 'TRANSPLANT' ) LAI= LAPE * NPLSB
IF (ESTAB.EQ. 'DIRECT-SEED') LAI= LAPE * NPLDS
END IF

```

After initialization, the largest section of the model follows, namely, the calculation of the rate variables (defined by ITASK = 2). The first two calculation “blocks” are reinitializations of state variables. The whole model ORYZA2000 starts the simulation at a specified start time, STTIME, which should be on or before emergence of the crop. The subroutine MODELS of ORYZA2000 checks whether the day of simulation has reached the user-supplied emergence date of the crop (EMD, Section 2.2.2). If so, CROPSTA gets the value of 1. In ORYZA1, weights of the crop parts (green (WLVG) and dead leaves (WLVD), stems (WST), storage organs (WSO), and roots (WRT), all in kg ha⁻¹), the development stage (DVS; -), and root length (ZRT; m) are reinitialized at emergence (IF CROPSTA.EQ.1) to values that were read from the experimental data file. The initial leaf area index (LAI_i ; ha leaf ha⁻¹ soil) is calculated from the product of the initial leaf area per plant at seedling emergence ($L_{p,0}$, LAPE; m² plant⁻¹) and the number of plants emerging per m² (N):

$$LAI_i = N \times L_{p,0} \quad (3.1)$$

If the crop is transplanted, the number of plants is the number of plants in the seedbed (NPLSB; number m⁻²); if the crop is direct-seeded, it is the number of plants emerging in the main field (NPLDS; number m⁻²). Both NPLSB and NPLDS were read from the experimental data file in the initialization section.

```

!-----Reinitialize rooting depth at day of transplanting
IF (CROPSTA .EQ. 3) THEN
  ZRT = ZRTTR
END IF

```

Another reinitialization takes place upon transplanting. If the crop is transplanted, the day of transplanting is indicated by CROPSTA = 3. At that day, the rooting depth is reinitialized to a new value (ZRTTR; m), which was read from the experimental data file in the initialization section.

```

!====Skip all rate calculations before emergence
IF (CROPSTA .GE. 1) THEN

```

<all rate calculations>

```

!-----Output section
IF (OUTPUT) THEN
  CALL OUTDAT (2, 0, 'DVS', DVS)
  .....
END IF

```

```

!=====Set exported variables for soil balance at 0 before emergence
      ELSE IF (CROPSTA .EQ. 0) THEN
            LAI      = 0.
            ALAI     = 0.
            LAIROL   = 0
      END IF
!=====End of skip all rate calculations before emergence

```

After these reinitializations, the true rate calculations follow. These are executed only from the day of emergence onward, as defined by CROPSTA is greater than or equal to 1. Before emergence (IF CROPSTA.EQ.0), the values for leaf area index (LAI), apparent leaf area index (ALAI), and rolled leaf area index (LAIROL) are kept at 0. These variables are passed on to the subroutines for evapotranspiration (Section 4.1) and soil-water balance (Section 6.2) and these statements are included to ensure correct communication with these subroutines.

At the end of the rate calculation section, output is written to the output data file, for example, 'CALL OUTDAT (2, 0, 'DVS', DVS)', using the write routines of the library TTUTIL (Section 2.4.2).

3.2 Rate calculations

```

!-----Set DROUT when leaf expansion is reduced in the
! vegetative growth phase (=> extra root growth)
      IF ((DVS.LT. 1).AND.(LESTRS.LT.1.)) THEN
            DROUT = .TRUE.
      ELSE
            DROUT = .FALSE.
      END IF

```

First, the value of a logical variable, DROUT, is set depending on the drought stress conditions encountered as defined by the value of the variable LESTRS (leaf elongation stress factor). This variable (LESTRS) affects the maximum rooting depth of the crop when the crop is still in the vegetative phase of growth: if the development stage of the crop (DVS) is smaller than 1 (indicating the vegetative stage before flowering) and LESTRS is smaller than 1, DROUT gets the value .TRUE. In all other conditions, the value of DROUT is .FALSE. The value of LESTRS is 1 under conditions of potential production (set in the subroutine WNOSTRESS, Section 4.3). When ORYZA2000 is run with a water balance to simulate water-limited conditions, the value of LESTRS is calculated by the subroutine WSTRESS (Section 4.2.2) and passed on to ORYZA1. The logical variable DROUT is used in the state update section of ORYZA1 in the calculation of maximum rooting depth (see Section 3.3).

```

!-----Computation of weather variables
      IF (CROPSTA .LE. 2) THEN
          TMPCOV = TMPSB
      ELSE
          TMPCOV = 0.
      END IF
      TCOR = LINT2('TMCTB', TMCTB, ILTMCT, DOY)
      TMAX = TMMX+TCOR+TMPCOV
      TMIN = TMMN+TCOR
      TAV  = (TMIN+TMAX)/2.
      TAVD = (TMAX+TAV )/2.
      DTR  = RDD

```

Next, some weather variables are calculated or adjusted from the daily values as passed to ORYZA1 through the WEATHER system called in ORYZA2000 (Section 2.3). At some locations in Asia (Japan, China), farmers grow an early rice crop by raising the seedlings in a seedbed covered by plastic. This has the effect of a greenhouse so that the ambient air temperature is increased. During the seedbed period (defined by CROPSTA = 2), a fixed temperature increase (TMPCOV; °C) is assigned a value that was read from the experimental data file (TMPSB; °C). In Japan, the maximum temperature is raised by 9 °C based on preliminary observations by Horie (personal communication). If no cover is used, the value 0 should be supplied for TMPSB in the experimental data file (Section 7.2).

Temperature adjustments can also be made when one wants to explore the effects of future temperature changes such as those predicted by general circulation models. A temperature correction (TCOR; °C) is interpolated from a temperature adjustment table (TMCTB) that was read from the experimental data file in the initialization section of ORYZA1. TMCTB is a table of temperature increases as a function of day number. The linear interpolation of the daily value for temperature correction is done using the function LINT2 of the library TTUTIL (Section 2.4.1). If no temperature adjustment is required, the value 0 should be supplied for TMCTB in the experimental data file.

The daily maximum temperature used in ORYZA1 (TMAX; °C) is the sum of the daily maximum temperature passed to ORYZA1 from the WEATHER system (TMMX; °C) and the temperature corrections from using any cover (TMPCOV; °C) and from climate change predictions (TCOR; °C). The daily minimum temperature used in ORYZA1 (TMIN; °C) is the sum of the daily minimum temperature passed to ORYZA1 from the WEATHER system (TMMN; °C) and TCOR. Finally, the daily average temperature (TAV; °C) is calculated as the mean of maximum and minimum temperature and the daily average daytime temperature is calculated as the mean of daily maximum and daily average temperature.

The daily total radiation used in ORYZA1 (DTR; $\text{kJ m}^{-2} \text{d}^{-1}$) is equal to the value obtained from the WEATHER system (RDD; $\text{kJ m}^{-2} \text{d}^{-1}$).

```
!-----Counter for days after emergence
      RDAE = 1.
```

ORYZA1 keeps track of the number of days after emergence. The counter RDAE (d) is given the value of 1 day at each time step. The total number of days after emergence (DAE; d) is integrated in the integration section (Section 3.3).

3.2.1 Phenological development

```
!-----Phenological development
      CALL SUBDD (TMAX, TMIN, TBD, TOD, TMD, HU)
      CALL SUBCD (CROPSTA, TAV, TIME, NCOLD)
      CALL PHENOL(DVS, DVRJ, DVRI, DVRR, HU, DAYL, MOPP, PPSE, &
                 TS, SHCKD, CROPSTA, DVR, TSHCKD)
```

The development stage (DVS; -) of a plant defines its physiological age and is characterized by the formation of the various organs and their appearance. The most important phenological change is the one from the vegetative to the reproductive stage, determining the change in dry matter allocation over organs. As many physiological and morphological processes change with the phenological stage of the plant, accurate quantification of phenological development is essential in any simulation model for plant growth. The key development stages for rice are emergence (0), panicle initiation (0.65), flowering (1), and physiological maturity (2).

Temperature is the main driving force for phenological development (van Keulen et al 1982). However, in photoperiod-sensitive varieties, daylength determines the induction of flowering as well. The subroutine SUBDD calculates the daily effective heat units for phenological development (HU ; $^{\circ}\text{Cd d}^{-1}$), the subroutine PHENOL calculates the development rate DVR (d^{-1}) as a function of the development stage, heat units, and daylength, and the subroutine SUBCD calculates the number of days on which it is too cold for rice growth. When the number of subsequent cold days exceeds a given value, the crop dies and the model stops (Section 3.3). The development stage is the integral of the development rate (DVR ; $(^{\circ}\text{Cd})^{-1}$) over time expressed in degree-days. This development rate is the inverse of the period (expressed in $^{\circ}\text{Cd}$) required for completing a development unit (e.g., flowering to maturity).

Effective temperature for phenological development

```
SUBROUTINE SUBDD(TMAX, TMIN, TBD, TOD, TMD, HU)
      IMPLICIT NONE
!-----Formal parameters
      REAL TMAX, TMIN, TBD, TOD, TMD, HU
```



```

!-----Local parameters
      REAL    TD, TM, TT
      INTEGER I
      SAVE

      TM = (TMAX+TMIN)/2.
      TT = 0.
      DO I = 1,24
          TD = TM+0.5*ABS(TMAX-TMIN)*COS(0.2618*FLOAT(I-14))
          IF ((TD.GT.TBD).AND.(TD.LT.TMD)) THEN
              IF (TD.GT.TOD) TD = TOD-(TD-TOD)*(TOD-TBD)/(TMD-TOD)
              TT = TT+(TD-TBD)/24.
          END IF
      END DO
      HU = TT
      RETURN
      END

```

It has been observed in many crops that the rate of development is linearly related to the daily mean temperature above a base temperature up to an optimum temperature, beyond which the rate decreases, again linearly, until a maximum temperature is reached (e.g., Kiniry et al 1991). For temperatures below the base temperature or above the maximum temperature, the rate of development is zero. Three “cardinal” temperatures can therefore be identified: base temperature (T_{base} , TBD; °C), optimum temperature (T_{opt} , TOD; °C), and maximum temperature (T_{high} , TMD; °C). For rice, these values are typically 8, 30, and 42 °C, respectively (Gao et al 1992). This “bilinear” response is generally observed only when the daily temperatures are constant (e.g., in a controlled environment); if the temperature fluctuates between a minimum and a maximum value, as is the case in field environments, the response becomes more curvilinear, particularly near each cardinal temperature. Figure 3.2 shows the linear and curvilinear responses.

Although this curvilinear response to daily mean temperature can be described by complex exponential equations (e.g., Gao et al 1992, Yin 1996), the simpler approach used by Matthews and Hunt (1994) in their cassava model was used in ORYZA1. In this approach, they assume that the response of development rate to temperature over short time periods, such as one hour, is described by the bilinear model, and that the response to daily mean temperature is achieved by superimposing onto this model a temperature response approximated by a sine function alternating between the daily minimum (T_{min} , TMIN; °C) and maximum (T_{max} , TMAX; °C) temperatures (Fig. 3.2).

In ORYZA1, hourly temperature (T_d , TD; °C) is calculated from T_{min} and T_{max} according to the relation

$$T_d = (T_{\text{min}} + T_{\text{max}})/2 + (T_{\text{max}} - T_{\text{min}}) \cos(0.2618 (h - 14))/2 \quad (3.2)$$

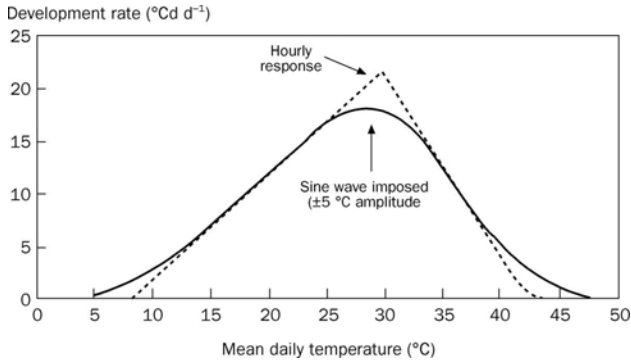

Fig. 3.2. The response functions of phenological development rate to temperature as used in ORYZA1. Simulations with $T_{\text{base}} = 8 \text{ }^{\circ}\text{C}$, $T_{\text{opt}} = 30 \text{ }^{\circ}\text{C}$, and $T_{\text{high}} = 42.5 \text{ }^{\circ}\text{C}$.

where h is the time of day. Hourly increments in heat units (HUH , $^{\circ}\text{Cd h}^{-1}$) are calculated according to

$$\begin{aligned}
 T_d \leq T_{\text{base}}, T_d \geq T_{\text{high}} &: HUH = 0 & (3.3) \\
 T_{\text{base}} < T_d \leq T_{\text{opt}} &: HUH = (T_d - T_{\text{base}})/24 \\
 T_{\text{opt}} < T_d < T_{\text{high}} &: HUH = [T_{\text{opt}} - (T_d - T_{\text{opt}}) \times (T_{\text{opt}} - T_{\text{base}})/(T_{\text{high}} - T_{\text{opt}})]/24
 \end{aligned}$$

where T_{base} is the base temperature, T_{opt} is the optimum temperature, and T_{high} is the maximum temperature for phenological development. The daily increment in heat units (HU or TT; $^{\circ}\text{Cd d}^{-1}$) is then calculated as

$$HU = \sum_{h=1}^{24} (HUH) \quad (3.4)$$

Low temperature and crop survival

```

SUBROUTINE SUBCD (CROPSTA, TAV, TIME, NCOLD)
  IMPLICIT NONE
  !-----Formal parameters
  REAL    TAV, TIME, NCOLD
  INTEGER CROPSTA
  SAVE

  IF (CROPSTA .EQ. 3) NCOLD = 0.
  IF (TAV.LT.12.) THEN
    NCOLD = NCOLD+1.
  ELSE
    NCOLD = 0.
  END IF

  IF (NCOLD.GT.3.) THEN

```

```

WRITE (*,'(A,/,A,F8.3,F6.1)') &
  '* * * Number of cold days (<12 C) exceeded 3 * * *', &
  ' NCOLD ',NCOLD,'at TIME=',TIME
END IF
RETURN
END

```

This subroutine was developed to ensure that the crop dies when the number of days on which the average temperature is lower than 12 °C exceeds 3. This estimate is based on calculations of T. Horie (personal communication).

Phenological development rate

In the subroutine PHENOL, the development rate of the crop is calculated based on development rate constants for the different phenological stages, the daily increment in heat units (HU; °Cd d⁻¹), and the photoperiod.

```

SUBROUTINE PHENOL(DVS,DVRJ,DVRI,DVRP,DVRR,HU,DAYL,MOPP,PPSE, &
                 TS,SHCKD,CROPSTA,DVR,TSHCKD)

  IMPLICIT NONE
  !-----Formal parameters
  REAL    DVS, DVRJ, DVRI, DVRP, DVRR, HU, DAYL, MOPP, PPSE
  REAL    TS, SHCKD, DVR, TSHCKD
  INTEGER CROPSTA
  !-----Local parameters
  REAL    DL, TSTR, PPFAC
  SAVE

  IF (DVS.GE.0..AND.DVS.LT.0.40) DVR = DVRJ*HU
  IF (DVS.GE.0.40.AND.DVS.LT.0.65) THEN
    DL = DAYL+0.9
    IF (DL.LT.MOPP) THEN
      PPFAC = 1.
    ELSE
      PPFAC = 1.-(DL-MOPP)*PPSE
    END IF
    PPFAC = MIN(1.,MAX(0.,PPFAC))
    DVR = DVRI*HU*PPFAC
  END IF
  IF (DVS.GE.0.65.AND.DVS.LT.1.00) DVR = DVRP*HU
  IF (DVS.GE.1.00) DVR = DVRR*HU

  IF (CROPSTA .EQ. 3) TSTR = TS
  TSHCKD = SHCKD*TSTR
  IF (CROPSTA .GT. 3 .AND.TS.LT.(TSTR+TSHCKD)) DVR = 0.
  RETURN
END

```

The life cycle of the rice crop is divided into four main phenological phases:

1. The basic vegetative phase (BVP), from emergence (DVS = 0) to the start of the photoperiod-sensitive phase (DVS = 0.4). The development rate constant in this phase is DVRJ.
2. Photoperiod-sensitive phase (PSP), from the end of the basic vegetative phase to panicle initiation (DVS = 0.65). The development rate constant in this phase is DVRI.
3. Panicle formation phase (PFP), from panicle initiation to (50%) flowering (DVS = 1). The development rate constant in this phase is DVRP.
4. Grain-filling phase (GFP), from (50%) flowering to physiological maturity (DVS = 2). The development rate constant in this phase is DVRR.

The photoperiod is calculated from the daylength +0.9 to account for the effect of low radiation levels after sunset and before sunrise. Each of these four phases has a variety-specific development rate constant, which is the inverse of the temperature sum required to complete a specific phase at the optimum photoperiod. Differences between varieties in total crop duration are usually caused by differences in the duration of the BVP rather than the other phases (Vergara and Chang 1985). Suboptimal photoperiods (daylength (DL; h) less than optimum photoperiod (MOPP; h)) will result in a longer photoperiod-sensitive phase (PPFAC<1.). The photoperiod sensitivity of a variety is quantified by the factor PPSE.

In transplanted rice, the situation becomes more complicated because of transplanting shock, which causes a delay in phenological development. Especially designed experiments found that the delay in phenological development is a function of the age of the seedlings that are transplanted, expressed in degree-days (TSTR; °Cd). In ORYZA1, the delay is expressed in degree-days (TSHCKD; °Cd), indicating the period after transplanting during which no development occurs. Figure 3.3 illustrates the procedure. The model starts at emergence and calculates the development rate and state. At transplanting, transplanting shock is determined from the seedling age expressed in degree-days, using the parameter SHCKD (degree-day delay per unit of seedling age (°Cd)) (Fig. 3.4). For this purpose, the temperature sum (TS) is calculated in the model in addition to the development stage (Section 3.3).

Drought stress and development rate

```
!-----Effect of drought stress on development rate
      IF (DVS.LT.1.0) THEN
          DVEW = LESTRS + (DVS*(1.-LESTRS))
      ELSE IF (DVS.GE.1.) THEN
          DVEW = 1.
      END IF
      DVR = DVR*DVEW
```

Drought in the vegetative stage of development delays flowering (Puckridge and O'Toole 1981, Turner et al 1986, Yoshida 1981). Wopereis et al (1996b) found that the delay in flowering decreased when drought occurred at later growth stages. In their experiments, postponement of flowering was in reasonable agreement with the number of days between the date of zero leaf expansion and the recovery from drought (Fig. 4.2, Section 4.2.2). This indicates that, if the soil is too dry to produce new leaves, the development rate

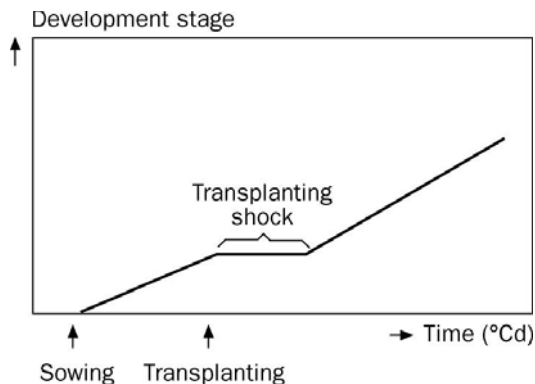

Fig. 3.3. Procedure for simulation of transplanting shock effect for phenological development. After transplanting, the development rate is 0 for a period expressed in degree-days (TSHCKD; °Cd).

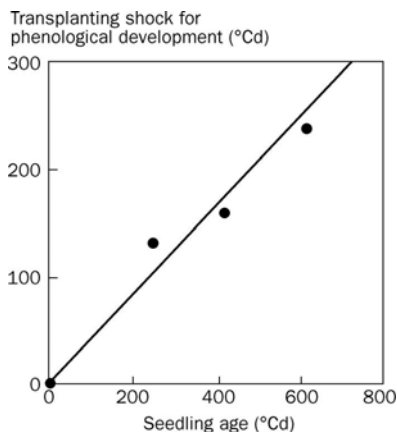

Fig. 3.4. Relation between the transplanting shock effect for phenological development in rice expressed in a period when no development occurs (TSHCKD; °Cd) and the seedling age at transplanting, also expressed in degree-days. Data are from a 1991 wet-season experiment with IR72 at IRRI, Los Baños, Philippines.

of the crop is brought to a standstill as well. Therefore, the leaf expansion reduction factor LESTRS is used to simulate the effect on delayed flowering in ORYZA1. The value of LESTRS is 1 under conditions of potential production (set in the subroutine WNOSTRESS, Section 4.3). When ORYZA2000 is run with a water balance to simulate water-limited conditions, the value of LESTRS is calculated by the subroutine WSTRESS (Section 4.2.2) and passed on to ORYZA1.

The delay in flowering is simulated through a reduction factor (DVEW) that acts on the development rate (DVR). After flowering ($DVS = 1$), DVEW is 1 and no more reduction takes place. Before flowering, DVEW equals the leaf expansion reduction factor LESTRS, which is modified to become smaller the closer the stress period is to flowering.

3.2.2 CO₂ assimilation of the canopy

Gross CO₂ assimilation and light absorption

```
!-----CO2 concentration
      CO2EFF = (1.-EXP(-0.00305*CO2 - 0.222)) &
              /(1.-EXP(-0.00305*CO2REF-0.222))
      EFF = LINT2('EFFTB',EFFTB,ILEFFT,TAVD)*CO2EFF

!-----Leaf rolling under drought stress (only for photosynthesis)
      LAIROL = LAI*(0.5*LRSTRS+0.5)

!----- Add specific stem area to leaf area
      SSGA = LINT2('SSGATB',SSGATB,ILSSGA,DVS)
      SAI = SSGA*WST
      ALAI = LAIROL+0.5*SAI

!-----Intercepted solar radiation
      KDF = LINT2('KDFTB',KDFTB,ILKDFT,DVS)
      REDFT = LINT2('REDFTT',REDFTT,ILREDF,TAVD)
      KNF = LINT2('KNFTB',KNFTB,ILKNFT,DVS)

!-----Daily gross canopy CO2 assimilation (DTGA)
      CALL GPParSet (CO2, KNF, NFLV, REDFT)
      CALL SGPCDT (1, IDOY , LAT , DTR , FRPAR, &
                  SCP, AMAX , EFF , KDF, ALAI , &
                  DAYL, DAYLP, DTGA, RAPCDT)
      PARI1 = RAPCDT/1.E6
      DPARI = RAPCDT/1.E6
      DPAR = FRPAR*DTR/1.E6
```

In ORYZA1, the subroutine SGPCDT is called to calculate daily total gross assimilation (DTAG or GPCDT; kg CO₂ ha⁻¹ d⁻¹) (see “Daily canopy photosynthesis” below). Note: this subroutine replaces the earlier subroutine TOTASP in Kropff et al (1994a). Important input parameters for this

subroutine are the day of the year (DOY), the latitude of the site (LAT; read from the experimental data file in the initialization section), the daily total radiation (DTR, RDD; $\text{kJ m}^{-2} \text{d}^{-1}$), the total green area index (ALAI, GAI; ha^{-1} soil), the extinction coefficients for visible light in the canopy (KDF, ECPDF; -), and, for N distribution in the canopy (KNF; -), the leaf N content (NFLV; g N m^{-2} leaf), the initial light-use efficiency of a single leaf (ε , EFF; $\text{kg CO}_2 \text{ ha}^{-1} \text{ h}^{-1}/(\text{J m}^{-2} \text{ s}^{-1})$), and the maximum rate of CO_2 assimilation of a single leaf (AMAX; $\text{kg CO}_2 \text{ ha}^{-1} \text{ h}^{-1}$).

The initial light-use efficiency of a single leaf (EFF) is read from a table as a function of average daytime temperature (TAVD) and is multiplied by a factor that accounts for the effect of CO_2 . For the effect of CO_2 , the relationship derived by Jansen (1990) from data by Akita (1980) and van Diepen et al (1987) was used:

$$\varepsilon = \varepsilon_{340 \text{ ppm}} \frac{(1 - \exp(-0.00305 \text{ CO}_2 - 0.222))}{(1 - \exp(-0.00305 \times 340 - 0.222))} \quad (3.5)$$

where $\varepsilon_{340 \text{ ppm}}$ is ε at a CO_2 concentration of 340 ppm and CO_2 is the ambient CO_2 concentration (ppm). This relationship (Eqn. 3.5) gives results similar to the theoretical relationship derived by Goudriaan and van Laar (1994).

Under drought stress, leaves may roll and their effective surface area for light interception and photosynthesis is reduced (O'Toole and Cruz 1980, Wopereis et al 1996b). In ORYZA1, the effective leaf area index is reduced by taking into account leaf rolling and the "rolled" leaf area index (LAIROL) enters the assimilation subroutines. LAIROL is calculated from the LAI and a leaf-rolling factor LRSTRS. The value of LRSTRS is 1 under conditions of potential production (set in the subroutine WNOSTRESS, Section 4.3). When ORYZA2000 is run with a water balance to simulate water-limited conditions, the value of LRSTRS is calculated by the subroutine WSTRESS (Section 4.2.1) and passed on to ORYZA1.

In most models, for canopy CO_2 assimilation, only light absorption by leaves is accounted for, although stems and reproductive organs such as panicles absorb a substantial amount of radiation. In rice, for example, stem (or sheath) area index (SAI) may be as high as $1.5 \text{ m}^2 \text{ stem m}^{-2}$ soil (M.J. Kropff and K.G. Cassman, IRRI, unpublished data). ORYZA1 accounts for CO_2 assimilation of the stem, by adding 50% of the green stem area (SAI) to the LAIROL, because sheaths are less photosynthetically active than leaves. This total green area index (ALAI; apparent leaf area index) enters the assimilation subroutines. The SAI is calculated as the specific stem area index (SSGA; ha kg^{-1} stem) times the weight of the green stems (WST; kg ha^{-1}). The SSGA is read from the crop data file as a function of the development stage (DVS) in the initialization section of ORYZA1 and daily values are interpolated using the function LINT2 from the library TTUTIL (Section 2.4.1).

The values for KDF and KNF are read from tables as a function of the development stage in the initialization section of ORYZA1. The leaf N content (NFLV; g N m⁻² leaf) is passed on to the model ORYZA1 from subroutines called in the main program ORYZA2000. For potential production situations, NFLV is read from the crop input data file as a function of development stage in the subroutine NNOSTRESS (Section 5.3). When ORYZA2000 is run with a nitrogen balance, the value of NFLV is calculated by the subroutine NCROP (Section 5.1.5) and passed on to ORYZA1.

The subroutine GPPARSET ensures that the values of CO₂, KNF, NFLV, and REDTF are available in various subroutines in which this subroutine is called (GPPARSET stores the values of these variables/parameters in a common block).

The subroutine SGPCDT calculates the daily total gross assimilation (DTGA; kg CO₂ ha⁻¹ d⁻¹) and, in a detailed manner, the daily rate of absorbed photosynthetically active radiation (RAPCDT; J m⁻² d⁻¹). In ORYZA1, a simpler procedure to keep track of absorbed photosynthetically active radiation (DPAR; MJ m⁻² d⁻¹) is executed as well by multiplying the fraction light interception (FPAR) by the daily total radiation (DTR).

```
!-----Unrolling of ALAI again
      ALAI = LAI+0.5*SAI
```

After the call to SGPCDT, the leaves are “unrolled” again and ALAI is equal to the unrolled LAI plus 50% of SAI.

```
!-----Effect of drought stress on DTGA
      DTGA = DTGA*PCEW
```

Crops under drought stress close their stomata to reduce transpiration. This increases the resistance to the gas exchange of CO₂, which decreases the rate of photosynthesis. Many authors have shown that there is a constant ratio of transpiration to gross photosynthesis under drought stress (de Wit 1958, Tanner and Sinclair 1983). This approach is adopted in ORYZA1 to reduce daily total gross assimilation (DTGA) as a function of relative transpiration ratio (PCEW). The value of PCEW is 1 under conditions of potential production (set in the subroutine WNOSTRESS, Section 4.3). When ORYZA2000 is run with a water balance to simulate water-limited conditions, the value of PCEW is calculated by the subroutine WSTRESS (Section 4.2.6) and passed on to ORYZA1. In WSTRESS, PCEW is calculated as the ratio of the actual transpiration of stressed plants (T_a , TRW; mm d⁻¹) over that of well-watered plants (T_p , TRC; mm d⁻¹).

Daily canopy photosynthesis

```
SUBROUTINE SGPCDT(IACC, IDOY, LAT, RDD, FRPAR, CSLV, AMAX, &
      EFF, ECPDF, GAI, DAYL, DAYLP, GPCDT, RAPCDT)
```

<Parameter declaration section>

IGSN = 3

DATA GSX /0.112702, 0.500000, 0.887298/

DATA GSW /0.277778, 0.444444, 0.277778/

```
! Compute daylength and related data
CALL SASTRO (IDOY,LAT, &
             SOLCON,ANGOT,DAYL,DAYLP,DSINB,DSINBE,SINLD,COSLD)
! Assimilation set at zero and three different times of the day
GPCDT = 0.
RAPCDT = 0.
DO I1=1,IGSN
! At the specified HOUR, external radiation conditions are computed
  HOUR = 12.0+DAYL*0.5*GSX(I1)
  CALL SSKYC (HOUR, SOLCON, FRPAR, DSINBE, SINLD, COSLD, RDD, &
             SINB, RDPDR, RDPDF)

! Assimilation rate of canopy is computed
  IF (IACC.EQ.1) THEN
! Choose three-point Gauss method
    CALL SGPC1 (CSLV,AMAX,EFF,ECPDF, GAI, SINB, RDPDR, RDPDF,&
              GPC, RAPC)
  ELSE IF (IACC.EQ.2) THEN
! Choose routine with internal error control
    CALL SGPC2 (CSLV,AMAX, EFF,ECPDF, GAI, SINB, RDPDR, RDPDF,&
              GPC, RAPC)
  END IF

  GPCDT = GPCDT +GPC *GSW(I1)
  RAPCDT = RAPCDT+RAPC*GSW(I1)
END DO

! Integration of assimilation rate to a daily total (GPCDT)
GPCDT = GPCDT *DAYL

! Integration of absorption rate to a daily total (RAPCDT)
RAPCDT = RAPCDT*DAYL*3600.

RETURN
END
```

The calculation procedure for the daily rate of crop CO₂ assimilation is schematically represented in Figure 3.5 and a flowchart of the various subroutines called appears in Figure 3.6.

The subroutine SGPCDT calls three subroutines:

1. SASTRO to calculate the solar constant (SOLCON; W m⁻²), daily extra-terrestrial radiation (ANGOT; J m⁻² d⁻¹), daylength (DAYL; h), and the

daily integral of the sine of the solar elevation over the day (DSINBE; $s\ d^{-1}$). This subroutine replaces the earlier subroutine ASTRO (Kropff et al 1994a).

- SSKYC to estimate the sine of the solar inclination (SINB; -) and fluxes of diffuse (RDPDF; $W\ m^{-2}$) and direct (RDPDR; $W\ m^{-2}$) radiation at a particular time of the day.
- SGPC1 or SGPC2 to compute instantaneous canopy CO_2 assimilation (GPC; $kg\ CO_2\ ha^{-1}\ soil\ h^{-1}$) and instantaneous absorbed photosynthetically active radiation (RAPC; $W\ m^{-2}$). These subroutines replace the earlier subroutine ASSIMP (Kropff et al 1994a).

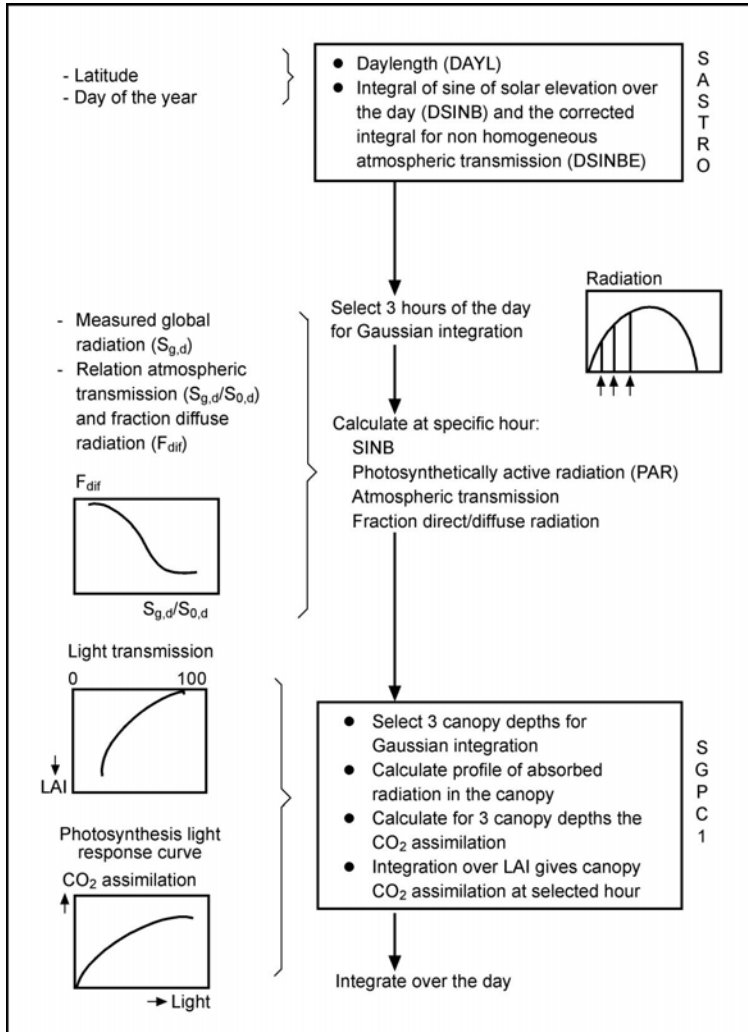

Fig. 3.5. Schematic representation of the calculation procedure for daily rates of canopy CO_2 assimilation in the subroutine SGPCDT.

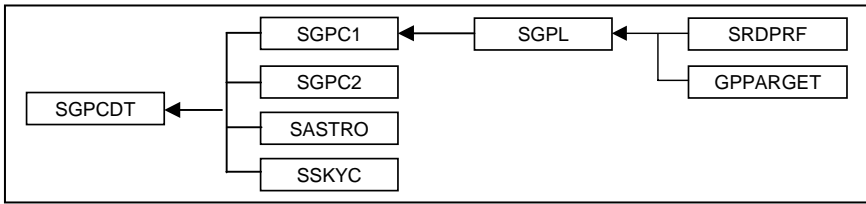

Fig. 3.6. Subroutines called by SGPCDT to calculate the daily rate of crop CO₂ assimilation.

The use of either SGPC1 or SGPC2 is governed by the setting of the variable IACC: when IACC equals 1, the subroutine SGPC1 is called, and when IACC equals 2, the subroutine SGPC2 is called. Both subroutines compute instantaneous CO₂ assimilation and instantaneous absorbed photosynthetically active radiation by the whole canopy. However, SGPC1 uses a Gaussian method to integrate assimilation rates and absorbed radiation over the depth of the canopy, whereas SGPC2 uses a more complex numerical integration method. The value of IACC is set in the argument list when the subroutine SGPCDT is called (see “Gross CO₂ assimilation and light interception” above). In the standard version of ORYZA2000, the value of IACC is 1, and the subroutine SGPC1 is used (see “Instantaneous canopy CO₂ assimilation” below).

The instantaneous values of canopy CO₂ assimilation and absorbed photosynthetically active radiation are integrated over the day into GPCDT and RAPCDT, respectively, using three-point Gaussian integration (Goudriaan 1986, Goudriaan and van Laar 1994). In this integration method, the integral of a function is calculated by selecting three x -values (here, x is time of the day). For these values, the y -values (here, instantaneous CO₂ assimilation and radiation intercepted) are calculated and a weighted average y -value is derived by using defined weights. The three points (GSX) have to be (1) at 0.5 of the integration interval, (2) at $(0.5 + \text{SQRT}(0.15))$ times the interval ($= 0.887298$), and (3) at $(0.5 - \text{SQRT}(0.15))$ times the interval ($= 0.112702$). For each of the three selected hours, a different weighting factor (GSW) is used to obtain the weighted average rates. The central point in the integration is assigned a greater weight, that is, 1.6 in comparison with the other two. When scaled to a sum of unity, the weights of the three points are 0.277778, 0.444444, and 0.277778, respectively. Because radiation is homogeneously distributed over the day according to the sine of the solar elevation, the weighted average CO₂ assimilation rate and the absorbed photosynthetically active radiation are calculated for half a day only. Multiplying by the daylength results in the total daily values.

Astronomical parameters

SUBROUTINE SASTRO (IDOY, LAT, SOLCON, ANGOT, DAYL, DAYLP, &

DSINB , DSINBE, SINLD, COSLD)

<Parameter declaration section>

```
! PI and conversion factor from degrees to radians
PARAMETER (PI=3.1415927, DEGTRAD=0.017453292)

! Declination of the sun as a function of day number and
! calculation of daylength from intermediate variables
! SINLD, COSLD, and AOB

DEC = -ASIN (SIN (23.45*DEGTRAD)*COS (2.*PI*(DOY+10.)/365.))
SINLD = SIN (DEGTRAD*LAT)*SIN (DEC)
COSLD = COS (DEGTRAD*LAT)*COS (DEC)
AOB = SINLD/COSLD

IF (AOB.LT.-1.) THEN
  WRITE (*,'(2A)') ' WARNING from SASTRO: ', &
    'latitude above polar circle, daylength=0 hours'
  DAYL = 0.
  ZZCOS = 0.
  ZZSIN = 1.
ELSE IF (AOB.GT.1.) THEN
  WRITE (*,'(2A)') ' WARNING from SASTRO: ', &
    'latitude within polar circle, daylength=24 hours'
  DAYL = 24.
  ZZCOS = 0.
  ZZSIN = -1.
ELSE
  DAYL = 12.*(1.+2.*ASIN (AOB)/PI)
  DAYLP = 12.0*(1.+2.*ASIN ((-SIN(-4.*DEGTRAD)+SINLD)/COSLD)/PI)
  ZZA = PI*(12.+DAYL)/24.
  ZZCOS = COS (ZZA)
  ZZSIN = SIN (ZZA)
END IF

! Daily integral of sine of solar height (DSINB) with a correction
! for lower atmospheric transmission at lower solar elevations (DSINBE)

DSINB = 2.*3600.*(DAYL*0.5*SINLD-12.*COSLD*ZZCOS/PI)
DSINBE = 2.*3600.*(DAYL*(0.5*SINLD+0.2*SINLD**2+0.1*COSLD**2)- &
  (12.*COSLD*ZZCOS+9.6*SINLD*COSLD*ZZCOS+ &
  2.4*COSLD**2*ZZCOS*ZZSIN)/PI)

! Solar constant and daily extraterrestrial radiation
SOLCON = 1370.*(1.+0.033*COS (2.*PI*DOY/365.))
ANGOT = SOLCON*DSINB

RETURN
END
```

These calculations involve some empirical relationships that calculate the daylength and the integral of the sine of the solar angle from the day number and latitude (Goudriaan and van Laar 1994). First, the declination (DEC) is calculated from the day number. Then, the intermediate variables SINLD (-) and COSLD (-) are calculated to make the other equations simpler. The subroutine checks whether the geographic latitude supplied (LAT) is above, within, or below the polar circles (through the intermediate variable AOB), and appropriate corrections to the daylength and intermediate sine and cosine variables are made. After this, two versions of the integral of the sine of the solar elevation are calculated: the first (DSINB; $s \text{ d}^{-1}$) is the straightforward integral of the sine of the solar angle, which can be used to calculate daily total extraterrestrial radiation (ANGOT; $\text{J m}^{-2} \text{ d}^{-1}$); the second one (DSINBE; $s \text{ d}^{-1}$) is a modified integral for radiation at Earth's surface, which takes into account the effect of the daily course in atmospheric transmission. Transmission is lower near the margins of the day because of haze in the morning and clouds in the afternoon. Besides that, the path length of the solar radiation in the atmosphere is longer (Spitters et al 1986). DSINBE is used to calculate the actual radiation at a specific time of the day (see later). The solar constant (SOLCON; W m^{-2}) is calculated as a function of the day number because the distance between Earth and the sun is not constant over the year.

Diffuse and direct radiation

```
SUBROUTINE SSKYC (HOUR, SOLCON, FRPAR, DSINBE, SINLD, COSLD, RDD, &
                  SINB, RDPDR , RDPDF)
```

```
<Parameter declaration section>
```

```
! Hour on day that solar height is at maximum
PARAMETER (SOLHM=12.)

ATMTR = 0.
FRDIF = 0.
RDPDF = 0.
RDPDR = 0.

! Sine of solar inclination, 0.2617993 is 15 degrees in radians
SINB = SINLD+COSLD*COS ((HOUR-SOLHM)*0.2617993)

IF (SINB.GT.0.) THEN
! Sun is above the horizon
TMPR1 = RDD*SINB*(1.+0.4*SINB)/DSINBE
ATMTR = TMPR1/(SOLCON*SINB)
IF (ATMTR.LE.0.22) THEN
    FRDIF = 1.
ELSE IF (ATMTR.GT.0.22 .AND. ATMTR.LE.0.35) THEN
    FRDIF = 1.-6.4*(ATMTR-0.22)**2
ELSE
```

```

        FRDIF = 1.47-1.66*ATMTR
    END IF

!       Apply lower limit to fraction diffuse
        FRDIF = MAX (FRDIF, 0.15+0.85*(1.-EXP (-0.1/SINB)))

!       Diffuse and direct PAR
        RDPDF = TMPR1*FRPAR*FRDIF
        RDPDR = TMPR1*FRPAR*(1.-FRDIF)
    END IF
    RETURN
END

```

In this subroutine, the sine of the solar angle (SINB) is calculated at the specified hour first. Then the subroutine continues with the calculation of incident fluxes of diffuse sunlight, with incidence under various angles, and direct sunlight with an angle of incidence equal to the solar angle. It is important to distinguish between these fluxes because of the large difference in illumination intensity between shaded leaves (receiving only diffuse radiation) and sunlit leaves (receiving both direct and diffuse radiation) and the nonlinear CO₂ assimilation-light response of single leaves (see calculations of canopy photosynthesis in the subroutine SGPL, next section). The diffuse flux is the result of the scattering of sun rays by clouds, aerosols, and gases in the atmosphere. The two fluxes are calculated from solar short-wave radiation (wavelength 300–3,000 nm). The instantaneous short-wave radiation (TMPR1) is calculated from the daily total radiation (RDD; kJ m⁻² d⁻¹) by multiplying the daily total by the ratio of the actual effective SINB (SINB × (1 + 0.4 × SINB)) over the integral of the effective SINB (DSINBE).

The fraction of diffuse light (FRDF; F_{dif} in Fig. 3.5) in the total incident light flux depends on the status of the atmosphere, that is, cloudiness and concentration of aerosols. This fraction is calculated from the atmospheric transmission (ATMTR) using an empirical function. The nonlinear relationship between FRDF and ATMTR is based on data from different meteorological stations from a wide range of latitudes and longitudes and is described in the IF statement block (Spitters et al 1986). The atmospheric transmission is the ratio between actual irradiance ($S_{g,d}$ in Fig. 3.5, TMPR1) and the quantity that would have reached Earth's surface in the absence of an atmosphere ($S_{0,d}$ in Fig. 3.5). This theoretical radiation flux at Earth's surface, assuming 100% atmospheric transmission, can be calculated from the solar constant (SOLCON), which is the radiation flux perpendicular to the sun rays, multiplied by the sine of the solar elevation (β ; SINB), which changes during the day.

The fluxes of direct and diffuse radiation are then calculated from the fraction diffuse radiation (FRDIF). Half of this short-wave radiation (fraction called FRPAR) is photosynthetically active (i.e., wavelength 400–700 nm; also called visible radiation), and is used in the calculation procedure of the CO₂

assimilation rate of the canopy (see below). Thus, the values of diffuse photosynthetically active radiation (RDPDF) and direct photosynthetically active radiation (RDPDR) are calculated by multiplying the diffuse and direct radiation values by FRPAR.

Instantaneous canopy CO₂ assimilation

```
SUBROUTINE SGPC1 (CSLV, AMAX, EFF, ECPDF, GAI, SINB, RDPDR, RDPDF, GPC,
                 RAPC)
```

```
<Parameter declaration section>
```

```
PARAMETER (IGSN=3)
```

```
REAL GSX(IGSN), GSW(IGSN)
```

```
! Gauss weights for three-point Gaussian integration
DATA GSX /0.112702, 0.500000, 0.887298/
DATA GSW /0.277778, 0.444444, 0.277778/

! Selection of depth of canopy, canopy assimilation is set at zero
GPC = 0.
RAPC = 0.
DO I1=1,IGSN
    GAID = GAI * GSX(I1)
    CALL SGPL (CSLV , AMAX , EFF , ECPDF, GAI, GAID, SINB, &
              RDPDR, RDPDF, GPL , RAPL)
! Integration of local assimilation rate to canopy
! assimilation (GPC) and absorption of PAR by canopy (RAPC)
    GPC = GPC + GPL * GSW(I1)
    RAPC = RAPC + RAPL * GSW(I1)
END DO
GPC = GPC * GAI
RAPC = RAPC * GAI
RETURN
END
```

In the subroutine SGPC1, the instantaneous rates of CO₂ assimilation of the whole canopy (GPC; kg CO₂ ha⁻¹ soil h⁻¹) and instantaneous absorbed radiation (RAPC; W m⁻² leaf) are calculated. Again, a Gaussian integration procedure is used to integrate the rates of leaf CO₂ assimilation and absorbed radiation over the canopy green area index (GAI; ha (leaf and stem) ha⁻¹ soil). The procedure follows the same pattern as the integration of instantaneous canopy CO₂ assimilation over time as explained above (see “Daily canopy photosynthesis”). Three selected depths in the canopy are chosen (GSX) at which the amounts of absorbed radiation and leaf CO₂ assimilation are calculated. By using the integration weights (GSW), the weighted average rates of leaf CO₂ assimilation and absorbed radiation are simulated and total values are obtained by

multiplication by the total GAI.

The instantaneous CO₂ assimilation rate at a single depth in the crop canopy is calculated with the subroutine SGPL.

```
SUBROUTINE SGPL (CSLV , AMAX1, EFF1 ,ECPDF, GAI, GAID, SINB, &
                RDPDR, RDPDF, GPL , RAPL)

    <Parameter declaration section>
    PARAMETER (IGSN=3)

!   Gauss weights for three-point Gaussian integration
    DATA GSX /0.112702, 0.500000, 0.887298/
    DATA GSW /0.277778, 0.444444, 0.277778/

!   Selection of depth of canopy, canopy assimilation is set at zero
    CALL SRDPRF (GAID,CSLV,SINB,ECPDF,RDPDR,RDPDF, &
                RAPSHL,RAPPPL,FSLLA)

!   Get photosynthesis parameters
    CALL GPPARGET (GAI,GAID,AMAX1,EFF1,AMAX2,EFF2)

!   Assimilation of shaded leaf area
    IF (AMAX2.GT.0.) THEN
        GPSHL = AMAX2 * (1.-EXP (-RAPSHL*EFF2/AMAX2))
    ELSE
        GPSHL = 0.
    END IF

!   Assimilation of sunlit leaf area
    GPSLL = 0.
    RAPSLL = 0.
    DO I1=1,IGSN
        TMPR1 = RAPSHL + RAPPPL * GSX(I1)
        IF (AMAX2.GT.0.) THEN
            GPSLL = GPSLL + AMAX2 * (1.-EXP(-TMPR1*EFF2/AMAX2))*GSW(I1)
        ELSE
            GPSLL = 0.
        END IF
        RAPSLL = RAPSLL + TMPR1 * GSW(I1)
    END DO

!   Local assimilation rate (GPL) and rate of
!   absorption of PAR by canopy (RAPL)
    GPL = FSLLA * GPSLL + (1.-FSLLA) * GPSHL
    RAPL = FSLLA * RAPSLL + (1.-FSLLA) * RAPSHL

    RETURN
    END
```

SGPL first calls two subroutines:

1. SRDPRF, to calculate the absorbed flux of radiation for shaded leaves (I_a , RAPS HL; $W\ m^{-2}\ leaf$), the direct flux absorbed by leaves (I_a , RAPPPL; $W\ m^{-2}\ leaf$), and the fraction of sunlit leaf area (FSLLA; -) at depth L in the canopy.
2. GPPARGET, to calculate the maximum photosynthesis rate (A_m , AMAX2; $kg\ CO_2\ ha^{-1}\ leaf\ h^{-1}$) and the initial light-use efficiency factor (ϵ , EFF2; $kg\ CO_2\ ha^{-1}\ leaf\ h^{-1} / (J\ m^{-2}\ leaf\ s^{-1})$) of a single leaf.

From the absorbed radiation at depth L , the assimilation rate at that specific canopy height is calculated for shaded and sunlit leaves separately. The CO_2 assimilation-light response of individual leaves follows a saturation type of function, characterized by an initial slope (the initial light-use efficiency) and an asymptote, and is described by the negative exponential function (Goudriaan 1982)

$$A_L = A_m (1 - \exp(-\epsilon I_a / A_m)) \quad (3.6)$$

where A_L is the gross CO_2 assimilation rate (GPSHL or GPSLL; $kg\ CO_2\ ha^{-1}\ leaf\ h^{-1}$), A_m is the CO_2 assimilation rate at light saturation (AMAX2), ϵ is the initial light-use efficiency (EFF2), and I_a is the amount of absorbed radiation (RAPS HL or RAPPPL).

For shaded leaves, the CO_2 assimilation rate is simply Eqn. 3.6. For sunlit leaves, the situation is more complicated. They absorb the flux that shaded leaves absorb (RAPS HL) plus the direct component of the direct flux (RAPPPL). However, the direct flux intensity differs for leaves with different orientation. Therefore, for sunlit leaves, CO_2 assimilation rates have to be calculated separately for leaves with different angles and integrated over all leaf angles. This again is done by Gaussian integration of CO_2 assimilation rates over the leaf angles. The procedure follows the same pattern as the integration of instantaneous canopy CO_2 assimilation over time as explained earlier (see "Daily canopy photosynthesis"). Here, a spherical leaf angle distribution is assumed. The same Gaussian integration is followed to calculate the absorbed radiation fluxes (RAPS LL). Finally, the assimilation rate per unit leaf area at a specific height in the canopy (GPL) is the sum of the assimilation rates of sunlit and shaded leaves, taking into account the proportion of sunlit (FSLLA) and shaded leaf area at that depth in the canopy. Similarly, the rate of absorption of photosynthetic radiation in the canopy (RAPL) is the weighted sum of the absorption rates of sunlit and shaded leaves.

Maximum leaf photosynthesis rate

SUBROUTINE GPPARGET (xGAI, xGAID, xAmaxIn, xEffIn, xAmaxOut, xEffOut)

<Parameter declaration section>

! Include common block

```

real cCO2, cKNF, cNFLV, cREDFT
common /gp_common/ cCO2, cKNF, cNFLV, cREDFT

!-----Calculate relative effect of CO2 level on AMAX
AmaxCO2 = 49.57/34.26*(1.-exp (-0.208*(cCO2-60.)/49.57))
AmaxCO2 = max (0.,AmaxCO2)

!-----Calculate leaf N for each layer, based on exponential extinction
if (xGAI.GT.0.01.AND.cKNF.GT.0.) then
    SLNI = cNFLV*xGAI*cKNF*exp(-cKNF*xGAID)/(1.-exp(-cKNF*xGAI))
else
    SLNI = cNFLV
end if

!-----Calculate actual photosynthesis from SLN, CO2, and temperature
! calculation of AMAX according to S. Peng (IRRI, unpublished):

if (SLNI.GE.0.5) then
    Amax = 9.5+(22.*SLNI)*cREDFT*AmaxCO2
else
    Amax = max (0.,68.33*(SLNI-0.2)*cREDFT*AmaxCO2)
end if
xAmaxOut = Amax
xEffOut = xEffIn
return
end

```

First, the maximum leaf CO₂ assimilation rate under high light intensity (A_m , AMAXCO₂; kg CO₂ ha⁻¹ leaf h⁻¹) is calculated as a function of the external (ambient air) CO₂ concentration (Fig. 3.7):

$$A_m = (49.57/34.26) \times (1 - \exp(-0.208 (CO_2 - 60.)/49.57)) \quad (3.7)$$

The maximum rate of CO₂ assimilation of a leaf (also called photosynthesis) (A_m , AMAXOUT; kg CO₂ ha⁻¹ leaf h⁻¹) is calculated from the maximum assimilation rate under the ambient CO₂ concentration, the N content of the leaves on an area basis (NFLV; g N m⁻² leaf), and a reduction factor that accounts for the effect of the average daytime temperature (REDFT, read from input data file in the initialization section of the model). Because the N content in the leaves is higher in the top leaves, the N profile in the canopy is taken into account. From observations, it was found that the N profile follows an exponential function with GAI counted from the top of the canopy with an extinction coefficient of about 0.4 around flowering (such as for radiation, see Eqn. 3.9). The relationship between leaf photosynthesis and specific leaf nitrogen (SLN; g N m⁻² leaf) is based on measurements on IR72 at IRRI (Peng et al, personal communication). For SLN levels below 0.5 g N m⁻² leaf, a relationship is used based on the assumption that A_m is 0 when SLN is 0.2.

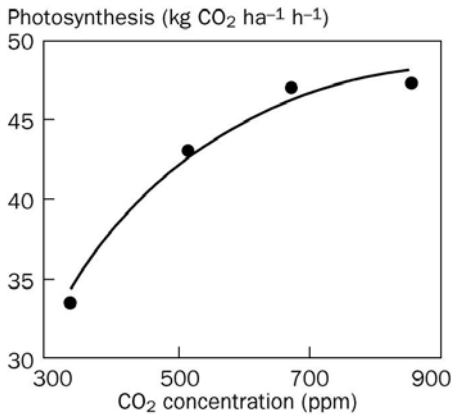

Fig. 3.7. Relationship between the maximum rate of leaf photosynthesis at 1 g N m⁻² and external CO₂ concentration during rice growth (data from Weerakoon, Olszyk, and Ingram, IRR/EPA).

Absorbed radiation

SUBROUTINE SRDPRF (GAID, CSLV, SINB, ECPDF, RDPDR, RDPDF, &
RAPSHL, RAPPPL, FSLLA)

<Parameter declaration section>

```
! Reflection of horizontal and spherical leaf angle distribution
TMPR1 = SQRT (1. - CSLV)
RFLH = (1. - TMPR1) / (1. + TMPR1)
RFLS = RFLH * 2. / (1. + 2. * SINB)

! Extinction coefficient for direct radiation and total direct flux
CLUSTF = ECPDF / (0.8*TMPR1)
ECPBL = (0.5/SINB) * CLUSTF
ECPTD = ECPBL * TMPR1

! Absorbed fluxes per unit leaf area: diffuse flux, total direct
! flux, direct component of direct flux
RAPDFL = (1.-RFLH) * RDPDF * ECPDF * EXP (-ECPDF * GAID)
RAPTDL = (1.-RFLS) * RDPDR * ECPTD * EXP (-ECPTD * GAID)
RAPDDL = (1.-CSLV) * RDPDR * ECPBL * EXP (-ECPBL * GAID)

! Absorbed flux (J/m2 leaf/s) for shaded leaves
RAPSHL = RAPDFL + RAPTDL - RAPDDL

! Direct flux absorbed by leaves perpendicular on direct beam
RAPPPL = (1.-CSLV) * RDPDR / SINB

! Fraction sunlit leaf area (FSLLA)
```

```
FSLLA = CLUSTF * EXP (-ECPBL*GAID)
```

```
RETURN
```

```
END
```

First, the reflection coefficient (TMPR1; -) is calculated. Incoming radiation is partly reflected by the canopy. The reflection coefficient of a green leaf canopy with a random spherical leaf angle distribution (ρ , RFLS; -), which indicates the fraction of the downward radiation flux that is reflected by the whole canopy, equals (Goudriaan 1977)

$$\rho = [(1 - \sqrt{(1 - \sigma)}) / (1 + \sqrt{(1 - \sigma)})] \times [2 / (1 + 2 \sin\beta)] \quad (3.8)$$

in which σ represents the scattering coefficient (transmission and reflection) of single leaves for visible radiation ($\sigma = 0.2$; CSLV) (Goudriaan, cited by Spitters 1986). A fraction $(1 - \rho)$ of the incoming visible radiation can be absorbed by the canopy.

The radiation that is not reflected enters the canopy. Radiation fluxes attenuate exponentially within a canopy with increasing leaf area from the top downward:

$$I_L = (1 - \rho) I_0 \exp(-k \times L) \quad (3.9)$$

where I_L is the net photosynthetically active radiation flux at depth L in the canopy (with a green area index, GAID, of L above that point) ($\text{J m}^{-2} \text{ soil s}^{-1}$), I_0 is the flux of photosynthetically active radiation at the top of the canopy ($\text{J m}^{-2} \text{ soil s}^{-1}$), L is the cumulative leaf area index (counted from the top of the canopy downward) ($\text{m}^2 \text{ leaf m}^{-2} \text{ soil}$), ρ is the reflection coefficient of the canopy (-), and k is the extinction coefficient for photosynthetically active radiation (-).

The diffuse and the direct flux have different extinction coefficients, which causes different light profiles within the canopy for diffuse and direct radiation. Therefore, three different fluxes of radiation are distinguished: (1) the diffuse flux (with extinction coefficient k_{df} (ECPDF; -)), (2) the total direct flux (with extinction coefficient $k_{\text{dr,t}}$ (ECPTD; -)), and (3) the direct component of direct radiation (with extinction coefficient $k_{\text{dr,bl}}$ (ECPBL; -), with *bl* for black since direct radiation becomes diffuse as soon as the sun ray is partly absorbed and scattered by a leaf).

For a spherical leaf angle distribution (homogeneous, random), the extinction coefficient equals

$$k_{\text{df,s}} = 0.8 \sqrt{(1 - \sigma)} \quad (3.10)$$

which is about 0.71 (Goudriaan 1977). However, in many situations, such as in rice, the leaf angle distribution is not spherical. In rice, the leaves are clustered (especially in the beginning as a result of planting on hills) and have a very vertical orientation. Other leaf angle distributions can be accounted for by a

procedure described by Goudriaan (1986), which calculates k_{df} based on the frequency distribution of leaves with angles in three classes (0–30°, 30–60°, and 60–90°). In the model, however, this is accounted for by using the cluster factor (Cf , CLUSTF), which is the measured extinction coefficient for diffuse light (ECPDF; $k_{df,m}$), relative to the theoretical one, for a spherical leaf angle distribution:

$$Cf = k_{df,m} / (0.8 \sqrt{(1 - \sigma)}) \quad (3.11)$$

where the extinction coefficient of the total direct flux $k_{df,m}$ is the measured extinction coefficient under the diffuse sky conditions, being input in the model (see also Section 7.3).

The extinction coefficient of the direct component of direct radiation $k_{dr,bl}$ (ECPBL) can be calculated as (Goudriaan 1977)

$$k_{dr,bl} = 0.5 Cf / \sin\beta \quad (3.12)$$

The extinction coefficient of the total direct flux $k_{dr,t}$ (ECPTD) can be calculated as (Goudriaan 1977)

$$k_{dr,t} = k_{dr,bl} \sqrt{(1 - \sigma)} \quad (3.13)$$

The light absorbed at a depth L in the canopy ($I_{a,L}$) is obtained by taking the derivative of Eqn. 3.9 with respect to the cumulative green area index:

$$I_{a,L} = -dI_L/dL = k(1 - \rho) I_0 \exp(-kL) \quad (3.14)$$

If expressed for the three different light components, the absorbed fluxes for the different components per unit leaf area at depth L in the canopy are

$$I_{a,df} = -dI_{df,L}/dL = k_{df}(1 - \rho) I_{0,df} \exp(-k_{df}L) \quad (3.15)$$

$$I_{a,dr,t} = -dI_{dr,t,L}/dL = k_{dr,t}(1 - \rho) I_{0,dr} \exp(-k_{dr,t}L) \quad (3.16)$$

$$I_{a,dr,dr} = -dI_{dr,dr,L}/dL = k_{dr,dr}(1 - \rho) I_{0,dr} \exp(-k_{dr,dr}L) \quad (3.17)$$

where $I_{a,df}$ is the absorbed flux of diffuse radiation (RAPDFL; $J m^{-2} leaf s^{-1}$), $I_{a,dr,t}$ is the absorbed flux of total direct radiation (RAPDDL; $J m^{-2} leaf s^{-1}$), and $I_{a,dr,dr}$ is the absorbed flux of the direct component of direct radiation (RAPDDL; $J m^{-2} leaf s^{-1}$).

Finally, the total absorbed fluxes by shaded leaves and by leaves perpendicular on the direct beam are calculated. The total absorbed flux for shaded leaves ($I_{a,sh}$, RAPSHL; $J m^{-2} leaf s^{-1}$) equals

$$I_{a,sh} = I_{a,df} + (I_{a,dr,t} - I_{a,dr,dr}) \quad (3.18)$$

The amount of the direct component of the direct flux absorbed by leaves perpendicular to the radiation ($I_{a,dr,dr}$, RAPPL; $J m^{-2} leaf s^{-1}$) beams equals

$$I_{a,dr,dr} = (1 - \sigma) I_{0,dr} / \sin\beta \quad (3.19)$$

The amount of direct radiation absorbed by leaves depends on the sine of incidence at the leaf surfaces.

The fraction sunlit leaf area (f_{sl} , FSLLA; -) equals the fraction of the direct radiation reaching that layer:

$$f_{sl} = Cf \exp(-k_{dr,bl} L_L) \quad (3.20)$$

where $k_{dr,bl}$ is the extinction coefficient for the direct component of direct radiation (ECPBL), Cf is the cluster factor (CLUSTF), and L_L is the green area index above depth L (GAID).

3.2.3 Dry matter partitioning

```
!-----Relative growth rates of shoots and roots
FSH = LINT2('FSHTB',FSHTB,ILFSHT,DVS)
FRT = 1.-FSH
```

Any dry matter produced by the crop is partitioned between shoots and roots according to partitioning coefficients (pc_k , kg dry matter organ kg^{-1} dry matter crop) defined as a function of the phenological development stage (D):

$$pc_k = f(D) \quad (3.21)$$

FSH is the fraction dry matter partitioned to shoots and FRT is the fraction dry matter partitioned to roots. The partitioning coefficient FSH is interpolated from a partitioning table read (FSHTB) in the initialization section of ORYZA1 using the function LINT2.

```
!-----Effect of drought stress on shoot-root partitioning
IF (DVS.LT.1.) THEN
  FSH = FSH * LESTRS
  FRT = 1.-FSH
END IF
```

Carbohydrate partitioning between shoot and root under water stress is generally altered in favor of the root biomass (Brouwer 1965, O'Toole and Chang 1979, O'Toole and Moya 1981). When leaves stop expanding, photosynthesis is still going on and the level of reserve carbohydrates increases, which makes more of them available for growth of the root system (van Keulen and Seligman 1987). Hence, in ORYZA1, the effect of drought on partitioning of assimilates between shoot and root is computed from the leaf expansion factor, LESTRS. The value of LESTRS is 1 under conditions of potential production (set in the subroutine WNOSTRESS, Section 4.3). When ORYZA2000 is run with a water balance to simulate water-limited conditions, the value of LESTRS is calculated by the subroutine WSTRESS (Section 4.2.2) and passed on to ORYZA1.

```

!-----Relative growth rates of shoot organs
      FLV = LINT2('FLVTB',FLVTB,ILFLVT,DVS)
      FST = LINT2('FSTTB',FSTTB,ILFSTT,DVS)
      FSO = LINT2('FSOTB',FSOTB,ILFSOT,DVS)

```

Any dry matter allocated to the shoot is partitioned to the various groups of plant organs: FLV is the fraction dry matter partitioned to the leaves, FST to the stems, and FSO to the storage organs (all as a fraction of shoot dry matter growth). All partitioning coefficients are interpolated from partitioning tables read in the initialization section of ORYZA1 using the function LINT2.

```

!-----Check sink limitation based on yesterday's growth rates
!      and adapt partitioning of stem-storage organ accordingly
      IF (GRAINS) THEN
          IF (GGR.GE.(PWRR-WRR)) THEN
              FSO = MAX(0.,(PWRR-WRR)/(GCR*FSH))
              FST = 1.-FSO-FLV
          END IF
      END IF

```

If the daily growth rate of grains (GGR; kg grain ha⁻¹ d⁻¹) leads to a total grain weight (WRR; kg grain ha⁻¹) that is larger than the maximum total grain weight (PWRR; kg grain ha⁻¹), sink limitations to grain filling occur (the calculation of the grain growth rate is explained in Section 3.2.8). The partitioning coefficient for the storage organs then becomes limited by the weight increase that would not result in an exceedance of PWRR. Any surplus of the source-determined growth rate of the storage organ is allocated to the stems. Since the actual growth of the grains is calculated only later in the model, after the daily net growth rate is calculated, this reallocation is estimated from the grain growth rates of the previous time step.

3.2.4 Loss of green leaves and stem reserves

```

!-----Loss rates of green leaves and stem reserves
      LLV = NSLLV*WLVG*LINT2('DRLVT',DRLVT,ILDRLV,DVS)
      LSTR = INSW(DVS-1.,0.,WSTR/TCLSTR)

```

The death or loss rate of the leaves (LLV; kg leaf ha⁻¹ d⁻¹) is calculated from the weight of the green leaves (WLVG; kg leaf ha⁻¹) times a relative death rate of leaf weight. This relative death rate is interpolated as a function of development stage (DVS) from a table (DRLVT) that was read from the crop data file in the initialization section of the model. The loss rate of leaves is affected by the nitrogen status of the crop (van Keulen and Seligman 1987). In ORYZA1, this is taken into account by multiplying the leaf loss rate by the so-called N-stress factor that accelerates leaf death (NSLLV). The value of NSLLV is 1 under conditions of potential production (set in the subroutine

NNOSTRESS, Section 5.3). When ORYZA2000 is run with a nitrogen balance to simulate nitrogen-limited conditions, the value of NSLLV is calculated from the nitrogen status of the crop in the subroutine NCROP (Section 5.1.5) and passed on to ORYZA1.

The loss rate of stem reserves (LSTR; kg stem reserves ha⁻¹ d⁻¹) starts at flowering and is simulated by dividing the weight of stems (WST; kg leaf ha⁻¹) by a time coefficient (the inverse of the relative loss rate, TCLSTR).

3.2.5 Respiration

The assimilated CO₂ is converted into carbohydrates (CH₂O) in the CO₂ assimilation process. The energy for this reduction process is provided by the absorbed light. The overall chemical reaction of this complex process is

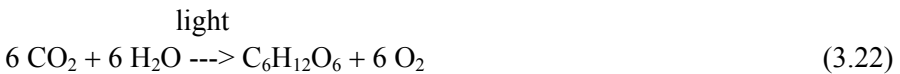

or, in a simplified form,



From this reaction, it follows that, for every kg of CO₂ taken up, 30/44 kg of CH₂O is formed—the numerical values representing the molecular weights of CH₂O and CO₂, respectively. Part of the carbohydrates produced in this process are respired to provide the energy for maintaining the existing biostructures. This process is characterized in the model as maintenance respiration. The remaining carbohydrates are converted into structural plant dry matter. The losses in weight as a result of this conversion are characterized as growth respiration.

Maintenance respiration

!-----Maintenance requirements

$$\text{TEFF} = \text{Q10}^{**}((\text{TAV}-\text{TREF})/10.)$$

$$\text{MNDVS} = \text{WLVG}/\text{NOTNUL}(\text{WLVG}+\text{WLVD})$$

$$\text{RMCR} = (\text{WLVG}*\text{MAINLV}+\text{WST}*\text{MAINST}+\text{WSO}*\text{MAINSO}+\text{WRT}*\text{MAINRT})*\text{TEFF}*\text{MNDVS}$$

Maintenance respiration provides the energy for living organisms to maintain their biochemical and physiological status. Through the reaction that is the reverse of CO₂ reduction in CO₂ assimilation, the radiation energy that was fixed in the photosynthetic process in a chemical form is released in a suitable form (ATP and NADPH):

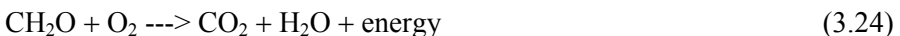

This process consumes roughly 15–30% of the carbohydrates produced by a

crop in a growing season (Penning de Vries et al 1989), which indicates the importance of accurate quantification of this process in the model. However, the process is poorly understood at the biochemical level and simple empirical approaches are inaccurate since it is impossible to measure maintenance respiration in the way it is defined (Penning de Vries et al 1989, Amthor 1984). The best way to quantify maintenance respiration is to measure the CO₂ production rate of plant tissue in the dark. The approach taken in the model is based on theoretical considerations, empirical studies, and studies in which the carbon balance in the model was evaluated using crop growth and canopy CO₂ assimilation data.

Three components of maintenance respiration can be distinguished at the cellular level: maintenance of concentration differences of ions across membranes, maintenance of proteins, and a component related to the metabolic activity of the tissue (Penning de Vries 1975). Maintenance respiration can thus be estimated from mineral and protein concentrations and metabolic activity as presented by de Wit et al (1978). In ORYZA1, an adapted version of the simple approach developed by Penning de Vries and van Laar (1982) is used, in which maintenance requirements are approximately proportional to the dry weights of the plant organs to be maintained:

$$R_{m,r} = mc_{lv} W_{lv} + mc_{st} W_{st} + mc_{rt} W_{rt} + mc_{so} W_{so} \quad (3.25)$$

where $R_{m,r}$ is the maintenance respiration rate at the reference temperature (25 °C) in kg CH₂O ha⁻¹ d⁻¹ (RMCR at 25 °C), W_{lv} , W_{st} , W_{rt} , and W_{so} are the weights of the leaves, stems, roots, and storage organs (WLVG, WST, WRT, WSO; kg dry matter ha⁻¹), respectively, and mc_{lv} , mc_{st} , mc_{rt} , and mc_{so} are the maintenance coefficients for leaves, stems, roots, and storage organs, respectively (MAINLV, MAINST, MAINRT, MAINSO; CH₂O kg⁻¹ DM d⁻¹), read from the crop data file in the initialization section of the model.

The maintenance coefficients (kg CH₂O kg⁻¹ dry matter d⁻¹) have different values for the different organs because of large differences in nitrogen contents. Standard values for maintenance coefficients are 0.03 for leaves, 0.015 for stems, and 0.01 for roots (Spitters et al 1989). For tropical crops, such as rice, lower values are used: 0.02 for the leaves and 0.01 for the other plant organs (Penning de Vries et al 1989). In ORYZA1, for mc_{so} a coefficient of 0.003 is used, which accounts for the small fraction of active tissue in the storage organs. Maintenance respiration can also be approached by using the coefficient for stem tissue for the active part (nonstored material) only.

The effect of temperature on maintenance respiration is simulated by the factor T_{eff} (TEFF), assuming a Q_{10} of 2 (doubling at every 10 °C increase) (Penning de Vries et al 1989):

$$R_m = R_{m,r} \times T_{eff} \quad (3.26)$$

$$T_{eff} = 2^{(T_{av} - T_r)/10} \quad (3.27)$$

where R_m is the actual rate of maintenance respiration (RMCR; kg CH₂O ha⁻¹ d⁻¹), T_{av} is the average daily temperature (TAV; °C), and T_r is the reference temperature (TREF; °C).

To account for the metabolic effect, a special reduction factor is introduced in ORYZA1, which accounts for the reduction in metabolic activity when the crop ages (MNDVS) (the NOTNUL statement is included to avoid division by zero, at emergence). In the current model, the total rate of maintenance respiration is assumed to be proportional to the fraction of green leaves and basically accounts for the decrease in N content of the leaves. This procedure for calculating the effect of age on maintenance respiration was used in the model SUCROS (Spitters et al 1989) and was based on studies in which measured crop growth and canopy CO₂ assimilation data were analyzed using a simple simulation model (Louwerse et al 1990).

Growth respiration

!Carbohydrate requirement for dry matter production (growth respiration)

$$CRGCR = FSH * (CRGLV * FLV + CRGST * FST * (1. - FSTR) + CRGSTR * FSTR * FST + CRGSO * FSO) + CRGRT * FRT$$

Carbohydrates in excess of maintenance costs are available for conversion into structural plant material. In the process of conversion, CO₂ and H₂O are released as scraps from the cut and paste process in biosynthesis. Following the reactions in the biochemical pathways of the synthesis of dry matter compounds (carbohydrates, lipids, proteins, organic acids, and lignin from glucose, CH₂O), Penning de Vries et al (1974) derived the assimilate requirements for the different compounds. From the composition of the dry matter, the assimilate requirements for the formation of new tissue can be calculated. Typical values for leaves (CRGLV), stems (CRGST), roots (CRGRT), and storage organs (CRGSO) (all in kg CH₂O kg⁻¹ dry matter) have been presented by Penning de Vries et al (1989). These values are read from the crop data file in the initialization section of the model. The average carbohydrate requirement for the whole crop (CRGCR) is calculated by weighting the coefficients with the fraction of dry matter allocation over the organs (FLV for leaves, FST for stems, FRT for roots, and FSO for storage organs).

3.2.6 Crop growth rate

!-----Gross and net growth rate of crop (GCR, NGCR)

$$GCR = ((DTGA * 30. / 44.) - RMCR + (LSTR * LRSTR * FCSTR * 30. / 12.)) / CRGCR$$

$$NGCR = MAX(0., GCR - LSTR * LRSTR * FCSTR * 30. / 12.)$$

The gross daily growth rate (G_p , GCR; kg dry matter ha⁻¹ d⁻¹) is calculated as follows:

$$G_p = (A_d \times (30/44) - R_m + R_t) / Q \quad (3.28)$$

where A_d is the daily rate of gross CO₂ assimilation (DTGA; kg CO₂ ha⁻¹ d⁻¹), R_m is the maintenance respiration costs (RMCR; kg CH₂O ha⁻¹ d⁻¹), R_t is the amount of available stem reserves for growth (LSTR; kg CH₂O ha⁻¹ d⁻¹), and Q is the assimilate requirement for dry matter production (CRGCR; kg CH₂O kg⁻¹ dry matter).

The amount of stem reserves that is reallocated (LSTR; see below) is multiplied by LRSTR (= 0.947) to account for 5.3% losses when reserves are allocated (Penning de Vries et al 1989). These reserves are expressed in CH₂O by multiplying by the fraction of carbon in the stem reserves (FCSTR) and the ratio of the molecular weights of CH₂O and C (30/12) to convert the carbon into assimilates that are available for new growth (dry matter production).

The net daily growth rate (NGCR; kg dry matter ha⁻¹ d⁻¹) is the gross value minus the reallocated amount of stem reserves.

3.2.7 Growth rates of crop organs

```
!-----Set transplanting effect
      IF (CROPSTA .EQ. 3) THEN
          PLTR = NPLH*NH/NPLSB
      ELSE
          PLTR = 1.
      END IF
```

At transplanting, the weights of the crop organs become “diluted” because seedlings are taken from a dense seedbed and transplanted at a much lower density in the main field:

$$D = (N_{pl,h} N_h) / N_{pl, sb} \quad (3.29)$$

where $N_{pl,h}$ is the number of plants per hill in the main field (NPLH), N_h is the number of hills per m² in the main field (NH), and $N_{pl, sb}$ is the number of plants per m² in the seedbed (NPLSB).

This dilution parameter D (PLTR) is calculated only at the day of transplanting (when CROPSTA equals 3); otherwise, its value is 1.

```
!-----Growth rates of crop organs at transplanting
      RWLVG1 = (WLVG*(1.-PLTR))/DELT
      GST1   = (WSTS*(1.-PLTR))/DELT
      RWSTR1 = (WSTR*(1.-PLTR))/DELT
      GRT1   = (WRT *(1.-PLTR))/DELT
```

The dilution parameter is used to calculate the reduction in net weight per unit area at transplanting for green leaves (RWLVG), stem reserves (RWSTR1), stems (GST1), and roots (GRT1) (all in kg dry matter ha⁻¹ d⁻¹).

```

!-----Growth rates of crop organs
      GRT  = GCR*FRT-GRT1
      GLV  = GCR*FSH*FLV-RWLVG1
      RWLVG = GLV-LLV
      GST  = GCR*FSH*FST*(1.-FSTR)-GST1
      GSTR = GCR*FSH*FST*FSTR-RWSTR1
      RWSTR = GSTR-LSTR
      GSO  = GCR*FSH*FSO
      IF (DVS.GT.0.95) THEN
          GGR = GSO
      ELSE
          GGR = 0.
      END IF

```

The growth rate of crop organ group k ($G_{p,k}$) is obtained by multiplying the total crop growth rate (G_p , Eqn. 3.28, GCR) by the fraction allocated to that organ group k (pc_k):

$$G_{p,k} = pc_k \times G_p \quad (3.30)$$

The dry matter available for growth is first distributed to the roots (GRT; kg dry matter ha⁻¹ d⁻¹), taking into account the reduction in weight caused by transplanting (GRT1). The shoot fraction is divided among leaves (GLV), stems (GST), and storage organs (GSO) using the earlier calculated partitioning factors (FLV, FSH, and FSO, respectively). For green leaves and stems, the reduction in weight because of transplanting (RWLVG1 and GST1, respectively) is taken into account. The net growth rate of the leaves (RWLVG; kg dry matter ha⁻¹ d⁻¹) is the growth rate of the leaves (GLV) minus their death rate (LLV). The growth rate of structural stem material is multiplied by (1. – FSTR) as the fraction allocated to the stem (FST) is based on total stem weight. The growth rate of the stem reserves pool (GSTR) is calculated in a similar way from FSTR. Just before flowering (after development stage, DVS, 0.95), it is assumed that all dry matter partitioned to the storage organs (GSO) goes into the grains (GGR).

3.2.8 Spikelet and grain formation

```

!-----Growth rate of number of spikelets and grains
      CALL SUBGRN (GCR,CROPSTA,LRSTRS,DVS,SF2,SF1,SPGF,TAV,TMAX, &
                  NSP,GNSP,GNGR,SPFERT,GRAINS)

```

The subroutine SUBGRN calculates the formation rate of spikelets (GNSP; number spikelets ha⁻¹ soil d⁻¹) and grains (GNGR; number grains ha⁻¹ soil d⁻¹) and the fertility of spikelets as a function of temperature around flowering. Horie et al (1992) developed the spikelet fertility routine. The current version of this subroutine also includes effects of drought stress on spikelet fertility.

```

SUBROUTINE SUBGRN(GCR,CROPSTA,LRSTRS,DVS,SF2,SF1,SPGF,TAV,TMAX,
                 NSP,GNSP,GNGR,SPFERT,GRAINS)

```

```

<Parameter declaration section>

```

```

<Initialization of variables to 0 before emergence>

```

```

!-----Temperature increase due to leaf rolling: 1.6 degree
!   per unit leaf rolling (Turner et al., 1986; p 269)
   TINCR = 5.*(1.-LRSTRS)*1.6

!-----Spikelet formation between panicle initiation and flowering
   DVSPI = 0.65
   DVSF  = 1.
   IF ((DVS.GE.DVSPi).AND.(DVS.LE.DVSF)) THEN
     GNSP = GCR*SPGF
   ELSE
     GNSP = 0.
   END IF

!-----Grain formation from spikelets (GNGR) and GNGR reduction factors
   IF ((DVS.GE.0.75).AND.(DVS.LE.1.2)) THEN
     CTT  = MAX(0.,22.-(TAV-TINCR))
     COLDTT = COLDTT+CTT
   END IF
   IF ((DVS.GE.0.96).AND.(DVS.LE.1.2)) THEN
     TFERT = TFERT +(TMAX+TINCR)
     NTFERT = NTFERT+1.
   END IF

!-----Apply GNGR reduction factors when DVS is 1.2 or more
   IF ((DVS.GE.1.2).AND.(.NOT.GRAINS)) THEN
     GRAINS = .TRUE.
     SF1    = 1.-(4.6+0.054*COLDTT**1.56)/100.
     SF1    = MIN(1.,MAX(0.,SF1))
     TFERT  = TFERT/(NTFERT)
     SF2    = 1./(1.+EXP(0.853*(TFERT-36.6)))
     SF2    = MIN(1.,MAX(0.,SF2))
     SPFERT = MIN(SF1,SF2)
     GNGR   = NSP*SPFERT
   ELSE
     GNGR   = 0.
   END IF

   RETURN
   END

```

In grain crops, carbohydrate production in the grain-filling period can be higher than the storage capacity of the grains, which is determined by the number of grains per m² and the maximum growth rate of the grains. This may

result in the accumulation of assimilates in the leaves, causing reduced rates of CO₂ assimilation through a feedback mechanism (Barnett and Pearce 1983). This can be very important in rice when it is grown in extreme environments as both low and high temperatures before flowering can induce spikelet sterility, which results in a low sink capacity (Yoshida 1981).

In wheat, it has been found that the size of the spike at flowering is proportional to the number of grains that are formed (Fischer 1985), and that spike size is closely correlated with the amount of growth of the crop during the spike formation period. The amount of growth over this period depends on both the duration of the period, which is influenced by temperature, and the crop growth rate, which is influenced by temperature and radiation. Similar relationships have been found in rice (Yoshida and Parao 1976) and were used by Islam and Morison (1992) to relate rice yields in Bangladesh to the “photothermal quotient” (Q), the ratio of solar radiation in the 30 days before flowering to the mean temperature over the same period minus a base temperature.

In experiments at IRRI, a good relationship was found between total crop growth over the period from panicle initiation to first flowering and the number of spikelets at flowering (Fig. 3.8). This relationship holds across the wet and dry seasons for levels of nitrogen application from 0 to 285 kg ha⁻¹, for planting densities from 25 to 125 plants m⁻², and for severe drought stress. A similar relationship is also found at the tiller level, so that the number of spikelets per tiller can be explained by the growth of each tiller during the period in which the panicle for that tiller is formed. The effects of solar radiation, temperature, nitrogen, competition, and water on spikelet formation, therefore, seem to be able to be integrated by their effects on crop growth over the panicle formation period. We have called the slope of this relationship the spikelet formation factor (γ). For a given variety, the relationship is remarkably consistent, although there do appear to be differences between varieties. For IR72, for example, γ has a value of about 65 spikelets g⁻¹ total dry matter, but ranges from about 45 to 70 spikelets g⁻¹ in several varieties used in experiments at IRRI.

In ORYZA1, the amount of growth from panicle initiation (defined as DVS = 0.65) to 50% flowering (defined as DVS = 1) is tracked, and the number of spikelets formed (S , GNSP; number of spikelets ha⁻¹ soil d⁻¹) is calculated as the product of this growth (G , GCR; kg dry matter ha⁻¹ soil d⁻¹) and γ (SPGF; number kg⁻¹) (all on day i):

$$S_i = \sum_{i=P}^F (G_i \times \gamma) \quad (3.31)$$

where P and F are the dates of panicle initiation and 50% flowering, respectively.

Spikelets turn into grains with crop growth. However, some spikelets become sterile because of either too high or too low temperatures and do not

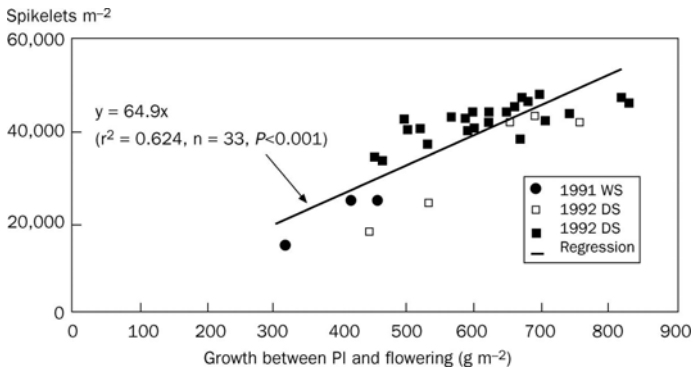

Fig. 3.8. The relationship between spikelet number m^{-2} and crop growth between panicle initiation and flowering (data from Kropff, Cassman, Torres, and Liboon (symbols \bullet , \square) and S. Peng (\blacksquare), IRRI, cultivar IR72).

fill. Spikelet sterility is calculated according to Horie et al (1992). Sterility caused by cold temperatures is based on the “cooling degree-day” concept (Uchijima 1976). The cooling degree-days (SQ_t , COLDDT; $^{\circ}Cd$) are calculated as follows:

$$SQ_t = \Sigma (22 - T_d) \quad (3.32)$$

where T_d is the average temperature (corrected for temperature increase caused by drought; see below). The summation of SQ_t is done for the period of highest sensitivity of the rice panicle to low temperatures ($0.75 \leq DVS \leq 1.2$). The relation between the percentage sterility caused by cold (S_c ; SF1) and the sum of the cooling degree-days (SQ_t) can be approximated by the equation (Fig. 3.9):

$$S_c = 1 - (4.6 + 0.054 \times SQ_t^{1.56}) / 100 \quad (3.33)$$

Rice spikelets are also sensitive to high temperature, particularly at anthesis. Damage to the pollen occurs when the temperature at flowering is above approximately $35^{\circ}C$ (Satake and Yoshida 1978, Matsui and Horie 1992). Figure 3.10 represents the relationship between the fraction of fertile spikelets caused by high temperatures (S_h , SF2; -) and the average daily maximum temperature ($T_{m,a}$, TFERT; $^{\circ}C$) over the flowering period ($0.96 \leq DVS \leq 1.22$) for Akihikari rice grown in a temperature gradient tunnel (Horie 1993) with elevated and ambient CO_2 concentrations. Figure 3.10 indicates that CO_2 concentration has no effect on the temperature and fertility relationship. The relation shown in Figure 3.10 can be approximated by

$$S_h = 1 / (1 + \exp(0.853 (T_{m,a} - 36.6))) \quad (3.34)$$

Daily maximum temperature is used to account for rice spikelets that usually flower during daytime.

Drought stress in the reproductive phase of crop development increases spikelet sterility, especially around flowering (Ekanayake et al 1989, Cruz and O'Toole 1984, O'Toole et al 1984). Turner et al (1986) found a relationship between temperature increase because of drought and increased spikelet sterility and related the increase in temperature to the leaf-rolling score. They found an increase of 1.6 °C with every unit of leaf rolling. We used this relationship between leaf rolling, expressed by the leaf-rolling factor (S_{rl} , LRSTRS; -), and increased temperature (T_i , TINCR; °C) to simulate increased spikelet sterility:

$$T_i = 5 (1 - S_{rl}) 1.6 \tag{3.35}$$

The value of LRSTRS is 1 under conditions of potential production (set in the subroutine WNOSTRESS, Section 4.3). When ORYZA2000 is run with a water balance to simulate water-limited conditions, the value of LRSTRS is calculated by the subroutine WSTRESS (Section 4.2.1) and passed on to ORYZA1.

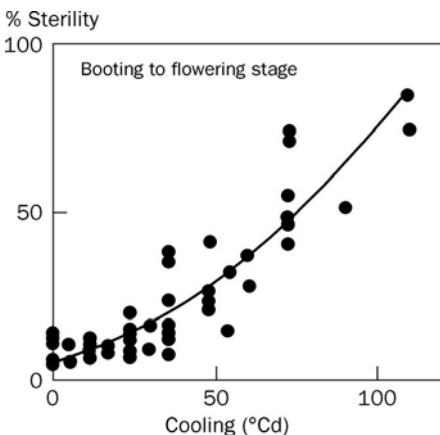

Fig. 3.9. Relation between cooling degree-days and percentage spikelet sterility (δ) of 'Eiko' rice between the booting and flowering stages (Horie 1988).

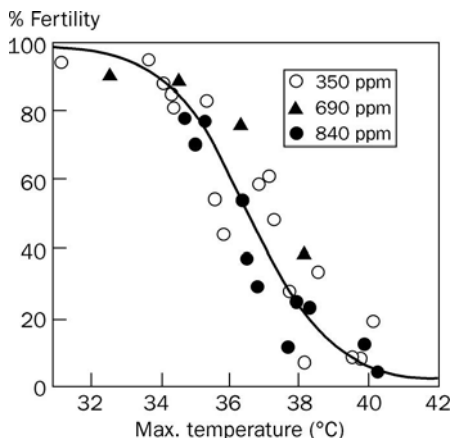

Fig. 3.10. Relation between average daily maximum temperature during the flowering period and spikelet fertility in 'Akihikari' rice acclimated to different CO₂ concentrations (Horie 1993).

Actual spikelet sterility (SPFERT; -) is calculated as the minimum of that caused by low temperature and that caused by high temperature. Finally, the growth rate of number of grains (GNGR) is calculated as the spikelet sterility factor times the growth rate of number of spikelets (GNSP).

3.2.9 Leaf area growth

```
!----- Temperature sum for leaf development
      CALL SUBDD (TMAX,TMIN,TBLV,30.,42., HULV)

!----- Specific leaf area
      IF (SWISLA .EQ. 'TABLE') THEN
          SLA = LINT2('SLATB',SLATB,ILSLAT,DVS)
      ELSE
          SLA = ASLA + BSLA*EXP(CSLA*(DVS-DSLA))
          SLA = MIN(SLAMAX, SLA)
      END IF

!----- Leaf area index growth
      CALL SUBLAI2(CROPSTA,RGRLMX,RGRLMN,TSLV,HULV, &
          SHCKL,LESTRS,RNSTRS,SLA,NH,NPLH,NPLSB,DVS,LAI, &
          ESTAB,RWLVG,DLDR,WLVG,GLAI, RGRL)
```

The green leaf area of plants determines the amount of absorbed light and thus CO₂ assimilation (together with the green area of stems; see above). The daily growth rate of leaf area index (GLAI; ha leaf ha⁻¹ soil d⁻¹) is calculated with the subroutine SUBLAI2. It contains two sections, one for transplanted rice and one for direct-seeded rice. In transplanted rice, there are three subsections: one for the exponential phase of growth, one for the day of transplanting, and one for the linear phase of growth. Phases one and three can occur in the seedbed as well as in the main field. In direct-seeded rice, there is no phase for the day of transplanting. In the phase of linear growth, the variable specific leaf area (SLA; m² leaf kg⁻¹ leaf) is required as an input. The SLA decreases in time with crop development and should be determined empirically as a function of development stage (DVS) from field experiments. There are two options in the model to obtain the SLA: the first is by interpolation of a user-defined look-up table of SLA as a function of DVS (read from the crop data file in the initialization section of ORYZA1) and the second is to use a smooth function between SLA and DVS by supplied function parameters (also read from the crop data file). The choice is governed by the user-defined switch parameter SWISLA: if its value is “table,” then the tabulated data are used; otherwise, the function is used (see also Section 7.3). The function has the form (Fig. 3.11)

$$SLA = a + b \times \exp(c \times (DVS - d)) \quad (3.36)$$

where a , b , c , and d are function parameters. The use of the smooth function prevents irregularities in the course of simulated LAI at transition points in the look-up table. In Fig. 3.11, the fitted function and the fitted line of the look-up table run through the top of the data points. In the whole calibration of ORYZA2000, such a fit produced more consistent and accurate simulations of crop growth across a large data set than SLA lines fitted through the center of the data of Fig. 3.11 (see also Section 8.2).

The subroutine SUBDD calculates the daily increment in temperature sum t_s (HULV; °Cd d⁻¹) using the same procedure to calculate heat units as for phenological development (Section 3.2.1; “Effective temperature for phenological development”). This temperature sum is needed in the determination of transplanting shock (see below).

```
SUBROUTINE SUBLAI2(CROPSTA,RGRLMX,RGRLMN,TSLV,HULV, &
                  SHCKL,LESTRS,RNSTRS,SLA,NH,NPLH,NPLSB,DVS,LAI, &
                  ESTAB,RWLVG,DLDR,WLVG,GLAI,RGRL)
```

<Parameter declarations>

```
IF (CROPSTA.LE.1) THEN
  X      = 1.
  TESTL  = .FALSE.
  TESTSET = 0.00001
END IF
```

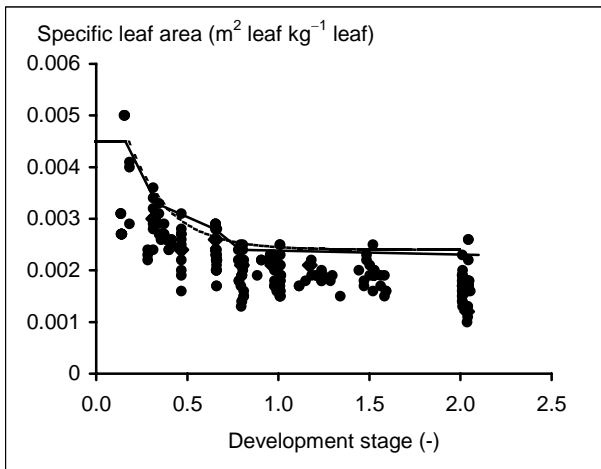

Fig. 3.11. SLA as a function of DVS. Data come from various experiments using IR72, IRRI. The lines represent the look-up table (dashed line) and the function (smooth line; Eqn. 3.36).

The daily leaf area growth rate is calculated with the subroutine SUBLAI2. After the declaration of parameters, separate rate calculations follow for transplanted rice and for direct-seeded rice.

Transplanted rice: growth in seedbed

```

!=====*
!-----Transplanted rice *
!=====*
!      Calculate RGRL as a function of N stress limitation
      RGRL = RGRLMX - (1.-RNSTRS)*(RGRLMX-RGRLMN)

      IF (ESTAB .EQ. 'TRANSPLANT') THEN
!----- 1. Seedbed; no drought stress effects in seedbed!
      IF (CROPSTA .LT. 3) THEN
        IF (LAI.LT.1.) THEN
          GLAI = LAI*RGRL*HULV
          WLVGEXS = WLVG
          LAIEXS = LAI
        ELSE
          TEST = ABS((LAI/NOTNUL(WLVG))-SLA)/SLA
          IF (.NOT. TESTL) THEN
            IF (TEST .LT. TESTSET) TESTL = .TRUE.
          END IF
          IF (TESTL) THEN
            GLAI = ((WLVG+RWLVG)*SLA)-LAI
          ELSE
            GLAI1 = ((WLVG+RWLVG-WLVGEXS)*SLA+LAIEXS)-LAI
            GLAI2 = ((WLVG+RWLVG)*SLA)-LAI
            GLAI = (GLAI1+X*GLAI2)/(X+1.)
            X = X+1.
          END IF
        END IF
      END IF

```

In the early phase of growth, the leaves do not shade each other and leaf area expansion is not limited by the amount of available assimilates but by temperature (Horie et al 1979). Thus, when the canopy is not closed, the plants grow exponentially as a function of the temperature sum (ts ; °Cd) (Fig. 3.12):

$$LAI_{ts} = LAI_{t_0} \times \exp(R_1 \times ts) \quad (3.37)$$

where LAI_{ts} is the leaf area index (ha leaf ha⁻¹ soil) at a specific temperature sum (ts ; °Cd) after emergence, LAI_{t_0} is the leaf area index at temperature sum zero, and R_1 is the relative leaf area growth rate (RGRL; (°Cd)⁻¹).

The growth in leaf area index ($gLAI$) is the derivative of Eqn. 3.37:

$$gLAI = LAI \times R_1 \times ts/\delta t \quad (3.38)$$

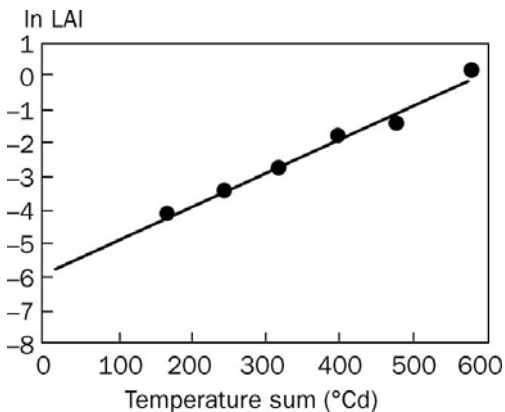

Fig. 3.12. The relation between the natural logarithm of leaf area of free-growing direct-seeded young rice plants and the temperature sum (°Cd). Data are from a wet-season 1991 experiment with IR72 at IRRI, Los Baños, Philippines (Kropff et al 1994b).

The daily increase in temperature sum $ts/\delta t$ (HULV; °Cd d⁻¹) is calculated by the subroutine SUBDD (see above). The exponential phase ends when the portion of assimilates allocated to nonleaf tissue increases sharply, or when mutual shading becomes substantial. As a yardstick for these events, LAI = 1 is used as the end of the exponential growth period, when leaves start to overlap. This can easily be checked by plotting ln(LAI) versus ts and determining the LAI up to which growth is linear (Fig. 3.12). The relative growth rate (R_l , RGRL) has to be empirically derived from field experiments. With nitrogen (N) limitation, assimilates may be in short supply during the exponential phase of growth. Kropff et al (1994a) observed values of RGRL of around 0.008 (°Cd)⁻¹ with optimal N supply, and of around 0.005 (°Cd)⁻¹ without any N fertilizer at the IRRI farm. On the basis of data from more N experiments at the IRRI farm, we found a maximum RGRL value of 0.0085 (°Cd)⁻¹ with no N limitation (RGRLMX) and of 0.0045 (°Cd)⁻¹ without N fertilizer (RGRLMN). The minimum value of RGRL occurred when the N content in the leaves (kg N kg⁻¹ dry matter) dropped to 90% of its maximum value. Therefore, a reduction factor for the relative leaf area growth rate is introduced to account for N limitation:

$$R_l = R_{lmax} - (1 - f_N)(R_{lmax} - R_{lmin}) \quad (3.39)$$

where R_l is the relative leaf area growth rate (RGRL; (°Cd)⁻¹), R_{lmax} is the maximum relative leaf area growth rate (RGRLMX; (°Cd)⁻¹), R_{lmin} is the minimum relative leaf area growth rate (RGRLMN; (°Cd)⁻¹), and f_N is the reduction factor for relative leaf area growth rate caused by N limitation (RNSTRS; -).

The values for RGRLMX and RGRLMN are read from the crop data file in the initialization section of ORYZA1. The value of RNSTRS is 1 under conditions of potential production (set in the subroutine NNOSTRESS, Section 5.3). When ORYZA2000 is run with a nitrogen balance to simulate possible nitrogen-limited conditions, the value of RNSTRS is calculated from the

nitrogen status of the crop in the subroutine NCROP (Section 5.1.5) and passed on to ORYZA1.

After the exponential growth phase, leaf area development is determined only by the amount of carbohydrates available for leaf growth (Penning de Vries et al 1989). In the so-called linear phase, there is a fixed relation between green leaf weight ($W_{lv\text{g}}$, WLVG; kg dry matter ha⁻¹) and green leaf area index (LAI), called the specific leaf area (SLA; m² leaf kg⁻¹ leaf):

$$LAI = SLA \times W_{lv\text{g}} \quad (3.40)$$

The leaf area index at the end of a day is calculated as this specific leaf area times the sum of the green leaf weight ($W_{lv\text{g}}$, WLVG) and the (net) increase in leaf weight that day ($gW_{lv\text{g}}$, RWLVG). The current leaf area index on the day of simulation is subtracted from the above product to obtain the growth in leaf area index ($gLAI$, GLAI):

$$gLAI = ((W_{lv\text{g}} + gW_{lv\text{g}}) \times SLA) - LAI \quad (3.41)$$

The different ways of modeling leaf growth in the exponential and linear phase can cause large jumps/dips in the simulated leaf area index on the transition point. To avoid this, previous versions of ORYZA1 implemented the linear growth in leaf area starting with the weight ($W_{lv\text{gexs}}$, WLVGEXS) and leaf area index (LAI_{exs} , LAIEXS) of the leaves at the end of the exponential phase (Kropff et al 1994a):

$$gLAI = (W_{lv\text{g}} + gW_{lv\text{g}} - W_{lv\text{gexs}}) \times SLA + LAI_{\text{exs}} - LAI \quad (3.42)$$

In this approach, only the increase in leaf weight is multiplied by the SLA to get the increase in leaf area. The ratio of simulated leaf area index (LAIEXS) over weight of leaves (WLVGEXS) at the end of the exponential phase, however, was then not the same as the “imposed” SLA (i.e., the values read from the crop data file). This resulted in imbalances between simulated weight and surface area of the leaves. Therefore, in this version of the model, we implemented a gradual transition between the exponential and linear phases of growth: a weighted mean of Eqns. 3.41 (GLAI2) and 3.42 (GLAI1) is applied until the difference (TEST) between the simulated SLA (i.e., simulated ratio of leaf area over leaf weight) and imposed SLA is less than 0.001% (TESTSET; value set in the initialization section of SUBLAI2). After that, only Eqn. 3.41 is used.

Transplanted rice: transplanting and transplanting shock

```
!----- 2. Transplanting effects: dilution and shock-setting
      ELSE IF (CROPSTA .EQ. 3) THEN
          TSLVTR = TSLV
          TSHCKL = SHCKL*TSLVTR
          GLAI   = (LAI*NH*NPLH/NPLSB) - LAI
```

On the date of transplanting, the seedling age in degree-days (TSLV; °Cd) is stored as TSLVTR. Based on this seedling age, the duration of the transplanting shock in degree-days is calculated (TSHCKL) (Figs. 3.13A and B). Leaf area becomes reduced at transplanting because of the dilution of the number of plants over a larger soil surface area. This is implemented in the model by a negative growth rate in leaf area index (GLAI) calculated from the dilution of the number of plants: number of plants per hill (NPLH) times the number of hills per square meter in the main field (NH), divided by the number of plants per square meter in the seedbed (NPLSB).

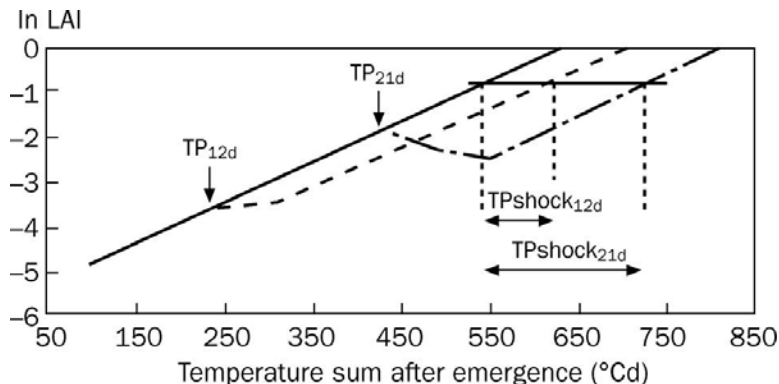

Fig. 3.13A. The relation between the natural logarithm of leaf area of free-growing direct-seeded and transplanted (at 12 days and 21 days after emergence) young rice plants and temperature sum (°Cd). Data are from a 1991 wet-season experiment with IR72 at IRRI, Los Baños, Philippines (Kropff et al 1994b).

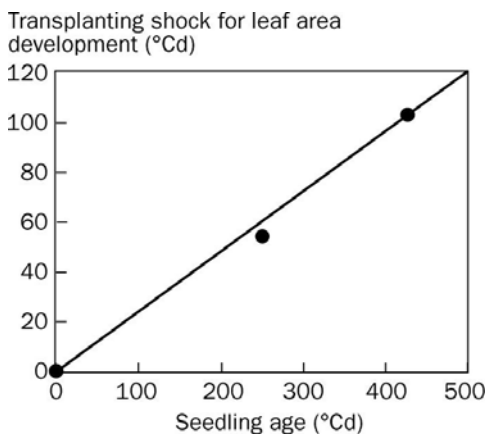

Fig. 3.13B. Relation between the transplanting shock effect on leaf area development in rice expressed as a period when no growth occurs (TSHCKL; °Cd) and the seedling age at transplanting, also expressed in degree-days. Data are from a 1991 wet-season experiment with IR72 at IRRI, Los Baños, Philippines (Kropff et al 1994b).

Transplanted rice: after transplanting

```

!-----3. After transplanting: main crop growth
      ELSE IF (CROPSTA .EQ. 4) THEN
!-----3.1. During-transplanting shock period
      IF (TSLV.LT.(TSLVTR+TSHCKL)) THEN
          GLAI = 0.

!-----3.2. After-transplanting shock
      ELSE
          IF ((LAI.LT.1.0).AND.(DVS.LT.1.0)) THEN
              GLAI = LESTRS * LAI*RGRL*HULV
              WLVGEXP = WLVG
              LAIEXP = LAI
          ELSE
!       There is a transition from RGRL to SLA determined growth when
!       the difference between simulated and imposed SLA is less than 10%
              TEST = ABS((LAI/NOTNUL(WLVG))-SLA)/SLA
              IF (.NOT. TESTL) THEN
                  IF (TEST .LT. TESTSET) TESTL = .TRUE.
              END IF
              IF (TESTL) THEN
                  GLAI = ((WLVG+RWLVG-DLDR)*SLA)-LAI
              ELSE
                  GLAI1 = ((WLVG+RWLVG-DLDR-WLVGEXP)*SLA+LAIEXP)-LAI
                  GLAI2 = ((WLVG+RWLVG-DLDR)*SLA)-LAI
                  GLAI = (GLAI1+X*GLAI2)/(X+1.)
                  X = X+1.
              END IF
          END IF
      END IF
  END IF
END IF

```

During the transplanting shock period, no LAI growth takes place ($GLAI = 0$). After the transplanting shock period, growth is exponential again when $LAI < 1$, and, when LAI exceeds 1, the SLA concept is used. The calculation procedures are exactly the same as during the seedbed period, except that now possible effects of drought are taken into account. It is assumed that, in transplanted rice, the seedbed is always provided with sufficient water for unrestricted growth, but this is not always the case in the main field. Leaf expansion rates of plants stressed in the vegetative phase decrease rapidly after an initial period of normal growth (Tanguilig et al 1987). Drought stress affects the growth rate of leaves in both the exponential and linear phase. In the exponential phase, the relative growth rate is multiplied by the leaf expansion reduction factor (f_{IN} , LESTRS; -) (compare with Eqn. 3.38):

$$gLAI = LAI \times f_{IN} \times R_1 \times ts/\delta t \quad (3.43)$$

The value of LESTRS is 1 under conditions of potential production (set in the subroutine WNSTRESS, Section 4.3). When ORYZA2000 is run with a water balance to simulate water-limited conditions, the value of LESTRS is calculated by the subroutine WSTRESS (Section 4.2.2) and passed on to ORYZA1.

In the linear growth phase, the leaf area index at the end of a day is calculated as the product of the specific leaf area and the sum of the green leaf weight (W_{lvg} , WLVG), the (net) increase in leaf weight that day (gW_{lvg} , RWLVG), and the loss rate of leaves because of drought that day (dW_{lvg} , DLDR) (compare Eqns. 3.41 and 3.42):

$$gLAI = ((W_{lvg} + gW_{lvg} - dW_{lvg}) \times SLA) - LAI \quad (3.44)$$

$$gLAI = ((W_{lvg} + gW_{lvg} - dW_{lvg} - W_{lvgexs}) \times SLA) + LAI_{exs} - LAI \quad (3.45)$$

The loss rate of leaves because of drought is explained in Section 3.2.10. In situations of potential production, or with ample irrigation water in the water-balance mode of ORYZA2000, this loss rate equals 0.

Direct-seeded rice

```

!=====*
!-----Direct-seeded rice *
!=====*
ELSE IF (ESTAB .EQ. 'DIRECT-SEED') THEN
    IF ((LAI.LT.1.0).AND.(DVS.LT.1.0)) THEN
        GLAI = LAI*RGRL*HULV * LESTRS
        WLVGEXP = WLVG
        LAIEXP = LAI
    ELSE
!       There is a transition from RGRL to SLA determined growth when
!       the difference between simulated and imposed SLA is less than 10%
        TEST = ABS((LAI/NOTNUL(WLVG))-SLA)/SLA
        IF (.NOT. TESTL) THEN
            IF (TEST .LT. TESTSET) TESTL = .TRUE.
        END IF
        IF (TESTL) THEN
            GLAI = ((WLVG+RWLVG-DLDR)*SLA)-LAI
        ELSE
            GLAI1 = ((WLVG+RWLVG-DLDR-WLVGEXP)*SLA+LAIEXP)-LAI
            GLAI2 = ((WLVG+RWLVG-DLDR)*SLA)-LAI
            GLAI = (GLAI1+X*GLAI2)/(X+1.)
            X = X+1.
        END IF
    END IF
END IF
RETURN
END

```

In the case of direct-seeded rice, the procedure is the same as for transplanted rice after transplanting.

3.2.10 Leaf death caused by drought

```
!-----Leaf death as caused by drought stress
DLDR = 0.
IF (LDSTRS.EQ.1.) THEN
  DLEAF = .FALSE.
  DLDRT = 0.
END IF
IF ((LDSTRS.LT.1.).AND.(.NOT.DLEAF)) THEN
  WLVGIT = WLVG
  DLEAF = .TRUE.
  KEEP = LDSTRS
END IF
IF (DLEAF) THEN
  IF (LDSTRS.LE.KEEP) THEN
    DLDR = (WLVGIT/DELT)*(1.-LDSTRS)-DLDRT/DELT
    KEEP = LDSTRS
    DLDRT = DLDR*DELT+DLDRT
  END IF
END IF
```

Drought accelerates the senescence and death rate of leaves (Lilley and Fukai 1994, Wopereis et al 1996a,b). In ORYZA1, the effect of drought on leaf death (accelerates senescence) is determined by the drought-induced dead leaf factor LDSTRS. The value of LDSTRS is 1 under conditions of potential production (set in the subroutine WNOSTRESS, Section 4.3). When ORYZA2000 is run with a water balance to simulate water-limited conditions, the value of LDSTRS is calculated by the subroutine WSTRESS (Section 4.2.3) and passed on to ORYZA1.

By default, the rate of leaf death caused by drought (DLDR; kg dead leaves caused by drought $\text{ha}^{-1} \text{d}^{-1}$) is set at 0. If LDSTRS equals 1, the logical DLEAF is set at .FALSE. (meaning that there is no drought stress for leaf death), and the total biomass of dead leaves caused by a drought event (DLDRT; kg dead leaves caused by drought ha^{-1}) is 0. If LDSTRS is lower than 1, then the variable WLVGIT registers the current green leaf biomass (WLVG), the logical DLEAF is set at .TRUE. (indicating a drought stress event), and the variable KEEP registers the value of LDSTRS. The amount of green leaf biomass (WLVGIT) cannot increase unless drought is removed. When the logical DLEAF is TRUE, the rate of leaf death (DLDR) is calculated from the green leaf biomass times a leaf death stress factor, minus the amount of accumulated dead leaves in that drought stress event (Wopereis 1996b). The leaf death stress factor is 1 minus LDSTRS. In subsequent time steps, the leaf death rate is 0

when the LDSTRS is higher than KEEP, and it gets a new value when it is lower than KEEP. Thus, the leaf death rate has a step-wise behavior in time. When the stress factor LDSTRS reaches 1 again, the drought is removed, the drought event is stopped, and DLDR and DLDRT are set at 0 again.

3.2.11 Crop growth rate and carbon balance check

```
!-----Growth respiration of the crop (RGCR)
CO2RT = 44./12.*(CRGRT *12./30.-FCRT )
CO2LV = 44./12.*(CRGLV *12./30.-FCLV )
CO2ST = 44./12.*(CRGST *12./30.-FCST )
CO2STR = 44./12.*(CRGSTR*12./30.-FCSTR)
CO2SO = 44./12.*(CRGSO *12./30.-FCSO )

RGCR = (GRT+GRT1)*CO2RT + (GLV+RVLVGL)*CO2LV + &
        (GST+GST1)*CO2ST + GSO*CO2SO+(GSTR+RWSTR1)*CO2STR+ &
        (1.-LRSTR)*LSTR*FCSTR*44./12.

CTRANS = RVLVGL*FCLV+GST1*FCST+RWSTR1*FCSTR+GRT1*FCRT
RTNASS = ((DTGA*30./44.-RMCR)*44./30.)-RGCR-(CTRANS*44./12.)

!-----Carbon balance check
CKCIN = (WLVG+WLVD-WLVGI)*FCLV+(WSTS-WSTI)*FCST+WSTR*FCSTR &
        +(WRT-WRTI)*FCRT+WSO*FCSO
CKCFL = TNASS*(12./44.)

CALL SUBCBC(CKCIN,CKCFL,TIME,CBCHK,TERMNL)
```

The total net daily rate of net CO₂ assimilation (RTNASS; kg CO₂ ha⁻¹ d⁻¹) is calculated from the gross CO₂ assimilation (DTGA; kg CO₂ ha⁻¹ d⁻¹) and the carbon losses as a result of maintenance respiration (RMCR; kg CH₂O ha⁻¹ d⁻¹) and growth respiration (RGCR; kg CO₂ ha⁻¹ d⁻¹). We take into account the amount of carbon “diluted” with transplanting (CTRANS; kg C ha⁻¹) (Section 3.2.7). Carbon losses as a result of losses through growth respiration are calculated from the dry matter growth rates multiplied by the CO₂ production factor (Penning de Vries et al 1989). This CO₂ production factor is calculated from the assimilate requirements of the organs (CRGRTR for roots, CRGLV for leaves, CRGST for stems, Section 3.2.5 on growth respiration) and the fraction of carbon in the dry matter produced. The numbers indicate the ratios of the molecular weights of carbon (12), CO₂ (44), and CH₂O (30):

$$CO2RT = 44./12. * (CRGRT *12./30. - FCRT)$$

in the dimension analysis:

$$CO_2 = CO_2/C \times (CH_2O/DM \times C/CH_2O - C/DM) = CO_2 \text{ per unit} \\ \text{of DM produced} \quad (3.46)$$

The part of the stem reserves is complex, because, during the translocation process, losses of 5.3% are accounted for in the model. Those losses are quantified in the calculation of RGCR.

The model contains a carbon balance check to make sure that total net assimilated carbon (CKCFL; kg C ha⁻¹) exactly equals the carbon fixed in dry matter and the carbon lost as a result of growth and maintenance respiration (CKCIN; kg C ha⁻¹). The model gives an error message (in the subroutine CBCHK) if the amount of carbon not accounted for is more than 0.1% of the total assimilated carbon. CKCIN is calculated by multiplying the weights of all crop organs by their fractions of carbon (Penning de Vries et al 1989).

3.3 Integration of states

```

!=====*
!      Integration section                                     *
!=====*
      ELSE IF (ITASK.EQ.3) THEN

!=====Skip whole state update before emergence
      IF (CROPSTA .GE. 1) THEN

< calculations>

!=====End of skip whole rate calculations before emergence
      END IF

```

State variables are updated in the integration section (ITASK .EQ. 3). Just as in the rate calculation section, these calculations are done only after emergence (when CROPSTA .GE. 1).

```

!-----Integrate rate variables
      PARCUM = INTGRL(PARCUM,DPARI,DELTA)
      PARCM1 = INTGRL(PARCM1,PARI1,DELTA)
      TS      = INTGRL(TS      ,HU      ,DELTA)
      TSLV   = INTGRL(TSLV   ,HULV   ,DELTA)
      DVS    = INTGRL(DVS    ,DVR    ,DELTA)
      WLVG   = INTGRL(WLVG   ,RWLVG-DLDR,DELTA)
      WLVD   = INTGRL(WLVD   ,LLV+DLDR ,DELTA)
      WSTS   = INTGRL(WSTS   ,GST    ,DELTA)
      WSTR   = INTGRL(WSTR   ,RWSTR ,DELTA)
      WSO    = INTGRL(WSO    ,GSO    ,DELTA)
      WRT    = INTGRL(WRT    ,GRT    ,DELTA)
      WRR    = INTGRL(WRR    ,GGR    ,DELTA)
      NGR    = INTGRL(NGR    ,GNGR   ,DELTA)
      NSP    = INTGRL(NSP    ,GNSP  ,DELTA)
      DAE    = INTGRL(DAE    ,RDAE  ,DELTA)
      TNASS  = INTGRL(TNASS  ,RTNASS ,DELTA)

```

Several state variables are integrated using the function INTGRL of library TTUTIL. For example, the cumulative amount of radiation absorbed by the canopy (based on the detailed calculations in subroutine SGPCDT, see above), PARCUM, is integrated by multiplying the daily rate of radiation absorbed by the canopy (DPARI) by the time step of integration (DELTA; 1 day), and adding this to the previous value of PARCUM. Similarly, temperature sums (TS, TSLV), development stage (DVS), weights of crop organs (WLVG, WLVD, WSTS, WSTR, WST, WRT, WRR), number of grains (NGR) and spikelets (NSP), days after emergence (DAE), and total net CO₂ assimilation (TNASS) are all calculated through integration with their rate variables. In the integration of the green (WLVG) and dead leaf weights (WLVD), the rate of leaf death caused by drought (DLDR) is taken into account.

```
!-----Calculate sums of states
      WST      = WSTS + WSTR
      WLVD     = WLVG + WLVD
      WAG      = WLVG + WST  + WSO
      WAGT     = WLVD + WST  + WSO
      TDRW     = WLVD + WST  + WSO + WRT

      PWRR     = NGR*WGRMX
      NGRM2    = NGR/10000.
      NSPM2    = NSP/10000.

!-----Weight of rough rice with 14% moisture
      WRR14   = (WRR/0.86)
```

After the integration of state variables, some of these are summed. For example, the total weight of leaves (WLV) is the sum of green (WLVG) and dead (WLVD) leaves. The maximum total grain weight (PWRR) is calculated as the number of produced grains (NGR) times the maximum single grain weight (WGRMX). The weight of rough rice is calculated from the dry weight of the grains (WRR) by considering 14% moisture.

```
!-----Leaf area index and total area index (leaves + stems)
      LAI      = INTGR2(LAI, GLAI, DELTA, FILEIT, 'LAI')
      ALAI     = LAI+0.5*SAI
```

The leaf area index (LAI) is integrated using the function INTGR2 from the library TTUTIL (Section 2.4.1). This function integrates a state variable with a rate variable (just as the function INTGR), but allows the use of observed values to “overrule” the simulated values. Observed values of LAI need to be supplied in the experimental data file, in the table LAI_OBS (Section 7.2). The parameter LAI_FRC (forcing switch), also set in the experimental data file, steers the choice of integration. If LAI_FRC = 0, then INTGR2 executes a normal integration of LAI using the rate variable GLAI. If LAI_FRC = 1, then interpolated values between observed LAI values are returned by INTGR2 for

the specific day of simulation. Only in the time span from emergence to the first observation of LAI are simulated values of LAI returned (i.e., integrated values), as in the time span from the last observation of LAI until the end of the simulation. The option to overrule simulated LAI values by observed values is useful in the evaluation of separate components of ORYZA1 (Kropff et al 1994a).

```
!-----Root length
      IF ((.NOT.DROUT).AND.(ZRT.LE.ZRTMCW)) THEN
        ZRTM = MIN(ZRTMCW,ZRTMS,TKLT)
      ELSE IF ((.NOT.DROUT).AND.(ZRT.GT.ZRTMCW)) THEN
        ZRTM = MIN(ZRT,ZRTMS,TKLT)
      ELSE IF (DROUT) THEN
        ZRTM = MIN(ZRTMCD,ZRTMS,TKLT)
      END IF
      ZRT = INTGRL(ZRT,GZRT,DELT)
      ZRT = MIN(ZRT,ZRTM)
```

Root depth is the integration of the root length growth rate GZRT (m d^{-1}) over time. GZRT is a parameter read from the crop data file in the initialization section of ORYZA1. The maximum root depth (ZRTM; m) is limited by the crop characteristic “maximum root depth of the crop” (under drought ZRTMCD, or under ample supply of water ZRTMCW; m), the maximum depth that roots can penetrate into the soil (ZRTMS; m), or the total depth of the soil profile modeled in the soil-water balance (TKLT; m). In principle, the total depth of the simulated soil profile, TKLT, in the soil-water balance should be larger than the maximum depth that roots can penetrate in the soil. The simulation of rooting depth is important when ORYZA2000 is run in the water-balance mode, since this determines the depth to which water can be extracted from the soil. The values of ZRTMS and TKLT are defined by the soil-water balance model and passed on to ORYZA1 (Section 6.2.1). If ORYZA2000 is run in the potential production mode, the values of ZRTMS and TKLT are set at 100 m in the subroutine MODELS and passed on to ORYZA1 (Section 2.2.2). Two variables quantify the maximum rooting depth as a crop characteristic. ZRTMCW is the maximum root depth when no drought occurs. However, under drought, roots may grow deeper (O’Toole and Chang 1979, O’Toole and Moya 1981). The maximum rooting depth under drought is defined by the crop characteristic ZRTMCW. Both ZRTMC and ZRTMCW are read from the crop data file in the initialization section of ORYZA1.

```
!=====Checks on simulation run
!-----If biomass is negative: set at 0 and abort simulation
      IF (WSO.LT.-5..OR.WLVG.LT.-5..OR.WST.LT.-5.) THEN
        WRITE (*,*) 'Negative biomass=> simulation stopped'
        CALL OUTCOM('Negative biomass => simulation stopped')
```

```

        IF (WSO.LT.0.) WSO = 0.
        IF (WST.LT.0.) WST = 0.
        IF (WLVG.LT.0.) WLVG = 0.
        TERMNL = .TRUE.
    END IF

```

When ORYZA2000 is run under severe stress conditions (in the water-balance or nitrogen-balance mode), the stress may be so severe that the crop dies and weights of crop organs become 0. The simulation run is terminated (TERMNL = .TRUE.) when the weight of the leaves, stems, or storage organs drops below zero (as a result of higher maintenance rates than assimilation rates).

```

!-----The following only in main field
        IF (CROPSTA .GE. 4) THEN
!           Check if lower limit for dead leaves is reached
                IF (LDSTRS.LE.0.) THEN
                        WRITE (*,*) 'Soil dryer than lower limit dead leaves'
                        WRITE (*,*) 'LDSTRS = 0 => Simulation stopped'
                        CALL OUTCOM('LDSTRS = 0 => simulation stopped')
                        TERMNL = .TRUE.
                END IF
!-----End if only in main field
        END IF

```

When the soil in the main field is so dry that all leaves have died, the whole crop is supposed to have died and the simulation is terminated. This threshold is checked by the value of the lower limit of the leaf death factor LDSTRS (Section 4.2.3).

```

!-----Terminate simulation settings
        IF (DVS.GT.2.) TERMNL = .TRUE.
        IF (NCOLD.GT.3.) TERMNL = .TRUE.

```

Finally, the last conditions for terminating a simulation run are set. A complete crop cycle stops at harvest, which can be either at or some days after physiological maturity. Maturity is defined by DVS = 2, so the simulation is stopped (TERMNL = .TRUE.) when the simulated DVS has passed 2.

It has been observed that rice dies when the cumulative number of days with temperatures below 12 °C (NCOLD) exceeds 3 (T. Horie, personal communication).

3.4 Terminal section

In the last section of the model, final statements are executed on the last day of a simulation run (defined by ITASK.EQ.4).

```

!=====*
!   Terminal section                               *
!=====*
      ELSE IF (ITASK.EQ.4) THEN
!   Terminal calculations
!   Terminal output
      CALL OPSTOR ('WRR14', WRR14)
      CALL OPSTOR ('WRR', WRR)
      CALL OPSTOR ('WSO', WSO)
      CALL OPSTOR ('WAG', WAG)
      CALL OPSTOR ('WAGT', WAGT)
      END IF

      RETURN
      END

```

Some variables are written to a short output file that contains only end-of-season values (OP.DAT; Section 7.7).

4 Evapotranspiration and water stress

The effects of water limitations on the growth and development of rice are simulated with two subroutines, ET and WSTRESS. ET calculates the potential evaporation rates of soil and water surfaces and potential transpiration rates of the crop. WSTRESS calculates actual transpiration and crop water uptake rates, and calculates the drought effect factors for the specific growth and development processes of the crop. Both subroutines are called in ORYZA2000 when the user-defined parameter PRODENV is set at 'WATER BALANCE' in the experimental data file (Section 7.2). The amount of rainfall and the amount of irrigation water applied determine to a large extent the level of drought stress that a rice crop will experience. Rainfall and irrigation water are inputs in the soil-water balance model that computes the daily soil-water tensions in the root zone (Section 6.2). If the rainfall and/or irrigation water supply is ample, the crop will not experience water limitations and the production situation is potential. Another way to simulate potential production is to run ORYZA2000 with PRODENV = 'POTENTIAL' (set in the experimental data file, see Sections 2.2.1 and 7.2). In this case, no soil-water balance is evoked and, instead of WSTRESS, the subroutine WNOSTRESS is called. This subroutine sets all drought stress effects at unity. Therefore, simulations with ORYZA2000 under potential production (PRODENV = 'POTENTIAL') are exactly the same as those with ORYZA2000 using a soil-water balance (PRODENV = 'WATER BALANCE') with an ample input of water (rainfall or irrigation).

All three subroutines (ET, WSTRESS, and WNOSTRESS) are called from the subroutine MODELS of ORYZA2000 (Section 2.2.2) and are divided into sections for initialization, rate calculations, state integrations, and terminal calculations. In the initialization section, all model state and rate variables are given an initial value (generally 0) and model parameters are read from the data file. This initialization section is not detailed further in the explanations below except for specific conditions.

4.1 Potential evapotranspiration

```
SUBROUTINE ET(ITASK, ANGA , ANGB , RDD , TMDA, VP , WN , LAT, &  
             IDOY , ETMOD, CROPSTA, NL , FAOF, WL0,      &  
             WCLQT, WCST , LAI , EVSC, ETD , TRC)
```

The subroutine ET calculates the potential evaporation rates of soil and water surfaces and potential transpiration rates of the crop. All calculations refer to the main field. This means that, in transplanted rice, the evaporation calcu-

lations before transplanting are for the bare field and not for the seedbed. It is assumed that the seedbed is always optimally provided with water. The evaporation and transpiration rates are calculated from the so-called reference evapotranspiration rate (ET_0 , ETD; mm d^{-1}), which is defined as “the rate of the evapotranspiration from an extensive surface of 8–15 cm tall, green grass cover of uniform height, actively growing, completely shading the ground, and not short of water” (FAO 1998). There are three options for calculating ET_0 : Penman (subroutine SETPMD), Priestley-Taylor (subroutine SETPTD), and Makkink (subroutine SETMKD). In general, the Penman equations are considered the best among the simple approaches to estimate ET_0 . Besides ET_0 , the Penman equations separately compute the radiation term (ET_{rd} , ETRD; mm d^{-1}) and the drying power term, also called the wind- and humidity-driven term (ET_{ae} , ETAE; mm d^{-1}). However, the Penman method requires more input data than the other two approaches. The choice of calculation method is user-defined by the parameter ETMOD in the experimental data file (Section 7.2). The value of this parameter is read in the subroutine MODELS and passed on to the subroutine ET. A full explanation of the subroutines SETPMD, SETPTD, and SETMKD is given by van Kraalingen and Stol (1997) and is not repeated here. The full text of their report is included on the CD-ROM accompanying this book. The bases of the calculation procedures are found in Penman (1948), Makkink (1957), and Priestley-Taylor (1972).

Table 4.1 summarizes the weather data requirements and computed outputs of the three subroutines to calculate ET_0 . If all weather data are available, the preferred choice is the Penman method. If only mean daily temperature or solar radiation (or sunshine hours) is available, the user can choose between the Priestley-Taylor and Makkink subroutines. Remember that a check is performed in the subroutine MODELS on the availability of appropriate weather data (Section 2.2.2). For example, if the Penman option is selected in

Table 4.1. Required input and computed output variables of the three subroutines to calculate reference evapotranspiration.

Item	Penman	Priestley-Taylor	Makkink
<i>Input parameters</i>			
Geographic latitude (LAT; dec. degr.)	x	x	
Surface reflection coefficient (RF; -)	x	x	
Ångström parameters (ANGA, ANGB; -)	x		
Daily solar radiation (RDD; $\text{kJ m}^{-2} \text{d}^{-1}$)	x	x	x
Mean daily temperature (TMDA; °C)	x	x	x
Wind speed (WN; m s^{-1})	x		
Vapor pressure (VP; kPa)	x		
<i>Computed output</i>			
Reference evapotranspiration (ETD; mm d^{-1})	x	x	x
Radiation term (ETRD; mm d^{-1})	x		
Drying power term (ETAE; mm d^{-1})	x		

the experimental data file and only radiation and temperature data are available in the weather data file, ORYZA2000 stops the simulation and reports an error message. The user can continue the simulation by selecting either the Priestley-Taylor or Makkink subroutine.

After the declaration of subroutine parameters, the evapotranspiration rates are calculated as daily rate variables (IF ITASK.EQ.2). The subroutine ET does not have initialization statements or integration of state variables.

```

      IF (ITASK.EQ.2) THEN

!---- Set value for reflection coefficient of soil or water background
!   If there is standing water:
      IF (WL0 .GT. 5.) THEN
          ALB = 0.05
          RFS = ALB

!   If there is moist or dry soil
      ELSE
          ALB = 0.25
          RFS = ALB*(1.-0.5*WCLQT(1)/WCST(1))
      END IF

!---- The soil or water background is shielded by the crop
      RF = RFS*EXP(-0.5*LAI)+0.25*(1.-EXP(-0.5*LAI))

```

The reflection of incident solar radiation from the surface (ρ , RF; -) is an input requirement for the Penman and Priestley-Taylor subroutines. This reflection is calculated from the reflection coefficient of the surface beneath the crop (ρ_s , RFS; -) and that of the crop (ρ_c , -) itself. The reflection coefficient of a crop surface is estimated to be 0.25. The reflection of the surface beneath the crop is computed from its so-called albedo (ALB , ALB ; -). The albedo of water is about 0.05 and that of dry soil varies from 0.14 for clay and dark soil to 0.42 for light sand (ten Berge 1989). In subroutine ET, we use an average value of 0.25. When the depth of ponded water in the field ($WL0$; mm) is more than 5 mm, the albedo of water is used; otherwise, the albedo of soil is used. The reflection coefficient of dry soil decreases when it gets wet. Following ten Berge (1989), we calculate the reflection coefficient of soil (ρ_s) from its dry albedo (ALB) and the ratio of actual water content (θ , $WCLQT(1)$; $m^3 m^{-3}$) over saturated water content (θ_s , $WCST(1)$; $m^3 m^{-3}$) of the topmost layer of the soil (as calculated by the soil-water balance, and passed on to ET):

$$\rho_s = ALB \times (1 - 0.5 \times \theta/\theta_s) \quad (4.1)$$

When the soil is saturated with water, the reflection coefficient is half the value of dry soil. The total reflection coefficient of the combined crop-soil/water surface (ρ) is the sum of the relative contributions of each surface. The relative contribution of each surface depends on the shading of the

soil/water background by the crop and is calculated on the basis of exponential extinction of radiation through a crop canopy (van Laar et al 1997):

$$\rho = \rho_s \exp(-k \times LAI) + \rho_c (1 - \exp(-k \times LAI)) \quad (4.2)$$

where LAI is the leaf area index (LAI ; ha leaf ha^{-1} soil) and k is the extinction coefficient for solar radiation (a value of 0.5 is used).

When LAI is 0, the reflection coefficient for bare soil or a water layer is obtained.

```
!-----Penman evapotranspiration
      IF (ETMOD.EQ.'PENMAN') THEN
!-----Set ISURF value (soil or water background) for wind function in
!      main field
!      Before transplanting: ISURF equals 1 = open water, or 2 = bare soil)
!      After transplanting: ISURF equals 3
          IF (CROPSTA .LT. 3) THEN
              IF (WL0 .GT. 5.) THEN
                  ISURF = 1
              ELSE
                  ISURF = 2
              END IF
          ELSE
              ISURF = 3
          END IF
          CALL SETPMD (IDOY,LAT,ISURF,RF,ANGA,ANGB,0.,RDD,TMDA,WN,VP, &
              ETD,ETRD,ETAE,DT)
```

After the reflection coefficients have been calculated, the value of ETMOD is checked and the appropriate evapotranspiration subroutine is called. The Penman equations use a so-called wind function to estimate the effect of wind speed on evapotranspiration. This wind function estimates the conductance for transfer of latent and sensible heat from the surface to the standard height of meteorological observations (2 m above a short grass canopy), and depends on roughness of the surface and atmospheric stability. Three standard roughness surfaces are recognized and implemented via the variable ISURF. The value 1 indicates open water, which we defined as standing water of more than 5 mm depth, the value 2 indicates bare soil, and the value 3 indicates a crop canopy. For transplanted crops, the main field is bare before transplanting (the crop growth stage variable CROPSTA is smaller than 3; Section 2.2.2) and ISURF is either 1 or 2 depending on the depth of standing water. After transplanting (CROPSTA is 4), the value of ISURF is 3. In direct-seeded crops, ISURF is 1 or 2 before sowing (CROPSTA smaller than 3) and 3 after sowing (CROPSTA is 4). After the correct value of ISURF is set, the Penman subroutine SETPMD is called.

```

!-----Makkink evapotranspiration
      ELSE IF (ETMOD.EQ.'MAKKINK') THEN
          CALL SETMKD (RDD, TMDA, ETD)

!           Estimate radiation-driven and wind- and humidity-driven part
          ETRD = 0.75*ETD
          ETAE = ETD-ETRD

!-----Priestley-Taylor evapotranspiration
      ELSE IF (ETMOD.EQ.'PRIESTLEY TAYLOR') THEN
          CALL SETPTD (IDOY,LAT,RF,RDD,TMDA,ETD)

!           Estimate radiation-driven and wind- and humidity-driven part
          ETRD = 0.75*ETD
          ETAE = ETD-ETRD
      END IF

```

The Makkink and Priestley-Taylor subroutines (SETMKD and SETPTD, respectively) calculate only total reference evapotranspiration ET_0 (ETD). It is estimated that 75% of ET_0 is caused by the radiation-driven part (ET_{rd} , ETRD) and 25% by the drying power part (ET_{ae} , ETAE).

```

!-----Multiplied by a factor according to FAO (1998)
      ETD = ETD * FAOF
      ETRD = ETRD * FAOF
      ETAE = ETAE * FAOF

```

The reference evapotranspiration obtained by any of the three procedures mentioned above refers to a grass cover grown in large fields. Actual reference evapotranspiration rates, however, may depend on local factors that are not addressed by these methods (FAO 1998). For instance, in semiarid and arid areas, irrigated fields surrounded by extensive dry fallow areas are subject to advection, which results in a “clothesline” effect at the upwind edge and an “oasis” effect inside the irrigated field. Also, (micro-)meteorological conditions in the field to be simulated may be different from those prevailing at the site of the meteorological station whose data are being used. Therefore, local conditions of the area under simulation may require a correction in the computed reference evapotranspiration rate ET_0 (and its radiation and drying power parts). In ET, the computed ET_0 is multiplied by a local correction factor, FAOF, which is read from the experimental data file in the subroutine MODELS and passed on to ET. See FAO (1998) for considerations on the value of FAOF.

```

!---- Calculate potential soil evaporation taking into account the
! standing crop
      EVSC = EXP(-0.5*LAI)*(ETRD+ETAE)
      EVSC = MAX (EVSC, 0.)
!---- Calculate potential transpiration of rice in main field

```

```

IF (CROPSTA .GE. 4) THEN
    TRC = ETRD*(1.-EXP(-0.5*LAI))+ETAE*MIN(2.0,LAI)
!   There is no transpiration from main field before transplanting
ELSE
    TRC = 0.
END IF

```

The radiation (ET_{rd}) and drying power (ET_{ac}) terms of the reference evapotranspiration rate are used to calculate the potential evaporation rate of the soil/water layer (E_p , EVSC; mm d⁻¹) and the potential transpiration rate of the crop (T_p , TRC; mm d⁻¹). With a crop cover, only radiation transmitted through the canopy is available for evaporation from the underlying soil/water layer (radiation term). The canopy also reduces the wind speed (drying power term). This “shielding” of the soil/water layer by the canopy is taken into account in the calculation of E_p :

$$E_p = (ET_{rd} + ET_{ac}) \exp(-k \times LAI) \quad (4.3)$$

where LAI is the leaf area index (LAI; ha leaf ha⁻¹ soil) and k is the extinction coefficient for solar radiation (a value of 0.5 is used).

The intercepted part of the radiation term, ET_{rd} , is used by the crop for transpiration (the transmitted radiation will reach the soil/water layer and contribute to soil/water evaporation). The drying power of the air, ET_{ac} , is effective only up to a cumulative leaf area index of 2 (van Laar et al 1997). Lower leaves do not contribute much to transpiration because little light penetrates deep into the canopy; hence, their stomatal resistance is higher. Also, air humidity is higher and wind speed is reduced. Therefore, the drying power term of the reference evapotranspiration is used only for the upper layer of the canopy:

$$T_p = ET_{rd} (1 - \exp(-k \times LAI)) + ET_{ac} \times LAI \quad (4.4)$$

4.2 Drought stress

```

SUBROUTINE WSTRESS (ITASK, DELT, OUTPUT, IUNITD, IUNITL, FILEI1, &
                    TRC, ZRT, TKL, NL, CROPSTA, &
                    WCLQT, WCWP, MSKPA, &
                    TRW, TRWL, LRSTRS, LDSTRS, LESTRS, PCEW)

```

The drought stress effects on growth and development of rice were derived from pot experiments at IIRI using cultivars IR20 and IR72. Wopereis et al (1996a,b) presented details of these experiments and derived the stress relationships used here. These stress relationships were validated in field experiments with controlled irrigation (Wopereis 1993). In WSTRESS, the following effects of drought on crop growth and development are taken into

account: leaf rolling, spikelet sterility, reduced leaf expansion rate, changed assimilate partitioning, increased root depth, delayed vegetative development, increased leaf senescence, and decreased photosynthesis rate (through decreased transpiration rate). For each of these processes, so-called stress factors are calculated in WSTRESS and passed on to the growth model ORYZA1 (Chapter 3).

All drought stress factors are defined as a function of the pF of the soil-water tension in the root zone. (Note: tension h is the negative value of soil water potential Ψ .) pF is defined as the logarithm of soil-water tension: $\log |10 \times h| = \text{pF}$, with tension h in kPa. For example, if the soil-water tension is 100 kPa, the corresponding pF value is 3. The advantage of expressing drought stress responses as a function of soil-water tension (rather than soil water content) is that they can be used for any soil type. Plants react, in principle, to soil-water tension since the uptake of water by the roots is governed by the difference in water tension in the crop (mainly leaves) and that felt by the roots in the soil. Soil-water tension is calculated by the water-balance model PADDY (Section 6.2).

All drought stress factors calculated in WSTRESS are multiplication factors and have values ranging from 0 to 1. The value 1 means that the crop growth process is not affected and the value 0 means that the process has come to a standstill.

```
<Parameter declaration section>
INTEGER    ..., NL,...
INTEGER    I, INL, J
PARAMETER (INL=10)

.....

REAL TINY
PARAMETER (TINY=0.000000001)
```

An important parameter in the stress calculations is the number of soil layers, NL, since all stress relations are calculated as a function of soil-water tension in each soil layer. The value of NL is defined in the soil-water balance model (Section 6.2.1) and passed on to WSTRESS. All array variables that store values per soil layer are declared with a fixed length of 10 (INL = 10). This is the maximum number of soil layers allowed (Section 6.2.1). The parameter TINY, with a very low value, is introduced as a number that can be added to variables in certain equations to avoid errors in arithmetic (e.g., such as taking the logarithmic value of a variable with value 0; see example below). After the declaration of parameters, module parameters are read from the crop data file and rate and state variables are given an initial value.

```
ELSE IF (ITASK.EQ.2) THEN
!-----Only stress in main field after day of transplanting
```

```

IF (CROPSTA .EQ. 4) THEN
  TRRM = TRC/(ZRT+1.0E-10)

  TRW = 0.
  ZLL = 0.
  LRAV = 0.
  LEAV = 0.
  LDAV = 0.

```

The stress factors are calculated in the rate calculation section (ITASK.EQ.2) and only for the main field (CROPSTA.EQ.4) after transplanting in the case of transplanted crops or after emergence in the case of direct-seeded rice. First, the total potential transpiration rate of the crop (T_p , TRC; mm d⁻¹) is divided by the rooted depth (Z , ZRT; m) to obtain the potential transpiration rate per unit of root length (T_{pz} , TRRM; mm d⁻¹ m⁻¹):

$$T_{pz} = T_p/Z \quad (4.5)$$

Next, some rate variables are initialized at 0 (see below for explanation of these variables).

```

DO I = 1,NL

!-----Root length in each soil layer
      ZRTL = MIN(TKL(I),MAX((ZRT-ZLL),0.0))

!-----Leaf-rolling factor
      <calculation section>

!-----Relative leaf expansion rate factor
      <calculation section>

!-----Relative death rate factor
      <calculation section>

!-----Relative transpiration ratio (actual/potential)
      <calculation section>

      ZLL = ZLL+TKL(I)

END DO

```

The drought stress factors are calculated separately for each soil layer where roots are present. A FORTRAN “DO-loop” sequentially executes the calculations for each layer, starting with number 1 and ending with layer number NL.

Next, the root length in each soil layer (ZRTL; m) is calculated as the minimum of the defined depth of the soil layer (TKL; m) (as defined in the soil-water balance model PADDY, Section 6.2.1) and the total root length (ZRT; m) minus the summed root depths of the preceding soil layers (ZLL; m). The value of ZLL is initialized at 0 at each time step before the DO-loop begins (see above) and is updated at the end of the DO-loop ($ZLL = ZLL + TKL(I)$).

The calculated root length in each layer will later be used as a weighting factor in the averaging of stress factors over all soil layers in the root zone.

4.2.1 Leaf rolling and spikelet sterility

```
!-----Leaf-rolling factor
      LR(I) = (LOG10(MSKPA(I)+TINY)-LOG10(LLS)) &
              / (LOG10(ULLS)-LOG10(LLS))
      LR(I) = LIMIT(0.,1.,LR(I))
      LRAV = LRAV+(ZRTL/(ZRT+TINY))*LR(I)
```

Leaves roll under drought stress. The rolling of leaves affects the amount of intercepted solar radiation for photosynthesis (Section 3.2.2). In our pot experiments, a 0–5 leaf-rolling score was monitored, based on O’Toole and Cruz (1980): a score of 0 indicates no leaf rolling, a score of 1 indicates the first signs of leaf rolling, and a score of 5 means that the leaves have completely rolled up. These scores were translated into the leaf-rolling factor (LR; -): a value of 1 indicates no leaf rolling and a value of 0 maximum leaf rolling. The relation between LR and the soil-water tension (h , MSKPA; kPa) is given in Figure 4.1. Leaf rolling started at soil-water tensions of about 200–300 kPa and dropped sharply to 0 at water tensions of about 400–1,000 kPa. We fitted a linear relationship between leaf-rolling score and $\log(h)$. This relationship is defined by the point at which the leaf-rolling factor starts to decrease from 1, called the upper limit for leaf rolling (ULLS; kPa), and the

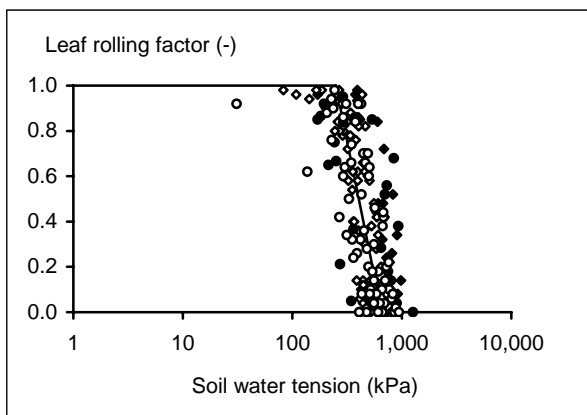

Fig 4.1. Leaf-rolling factor as a function of soil-water tension. Data are from Wopereis (1996b); \blacklozenge IR20 1992 DS, \diamond IR20 1992 WS; \bullet IR72 1992 DS, \circ IR72 1992 WS. The drawn line is the fitted relationship for cultivars IR20 and IR72.

point at which the leaf-rolling factor reaches 0, called the lower limit for leaf rolling (LLLS; kPa). The values of both LLLS and ULLS are empirically derived and read from the crop data file in the initialization section of the subroutine (Section 7.3).

For each soil layer, the value of the leaf-rolling factor (LR) is obtained by linear interpolation of the prevalent soil-water tension in that soil layer (MSKPA) between these lower and upper limits. Since the relationship between leaf rolling and soil-water tension is linear on a logarithmic scale, the values of MSKPA, ULLS, and LLLS are converted from kPa into pF units. A small value (TINY) is added to MSKPA to avoid arithmetic errors when MSKPA equals 0. The interpolated value of LR is limited from 0 to 1. The average leaf-rolling score of the whole rooted profile (LRAV; -) is obtained by summing the individual rolling factors for each layer, weighted by the ratio of the relative root length in that layer (ZRTL) to the total root length (ZRT). A small value (TINY) is added to ZRT to avoid arithmetic errors when ZRT equals 0. LRAV is initialized at 0 at each time step before the DO-loop begins (see above).

Besides the effect of leaf rolling on reduced canopy photosynthesis, the leaf-rolling factor is also used to simulate the effect of drought stress on spikelet fertility. We used a relationship derived by Turner et al (1986) between leaf rolling, expressed by the leaf-rolling factor, and temperature increase to simulate increased spikelet sterility in the model ORYZA1 (Section 3.2.8).

4.2.2 Leaf expansion, flowering time, assimilate partitioning, and rooting depth

```
!-----Relative leaf expansion rate factor
      LE(I) = (LOG10(MSKPA(I)+TINY)-LOG10(LLLE)) &
              / (LOG10(ULLE)-LOG10(LLLE))
      LE(I) = LIMIT(0.,1.,LE(I))
      LEAV = LEAV+(ZRTL/(ZRT+TINY))*LE(I)
```

Leaf expansion rates of plants stressed in the vegetative phase decrease rapidly after an initial period of normal growth (Tanguilig et al 1987). In our experiments, the critical soil-water tension at which leaf expansion stopped completely was estimated from graphs of observed plant height. Because plant height was measured at weekly intervals, these results should be interpreted as rough estimates only. Critical soil-water tensions ranged from 50 kPa (upper limit of leaf expansion, ULLE) to 260 kPa (lower limit of leaf expansion, LLLE). Critical tensions were lower in the wet season than in the dry season, probably because of the lower evaporative demand in the wet season. For younger plants, leaf expansion stopped at lower tensions, which may also be attributed to a lower evaporative demand of a small leaf canopy. The calculation of the reduced leaf expansion factor (LE per soil layer; LEAV as

average over the whole rooted depth) follows the same scheme as that of the leaf-rolling factor.

Drought in the vegetative stage of development delays flowering (Puckridge and O'Toole 1981, Turner et al 1986, Yoshida 1981). We found that the delay in flowering decreased when drought occurred at later growth stages. Postponement of flowering was in reasonable agreement with the number of days between the date of zero leaf expansion and the recovery from drought (Fig. 4.2). This indicates that, if the soil is too dry to produce new leaves, the development rate of the crop is brought to a standstill as well. Therefore, we use the leaf expansion factor to simulate the effect of drought on delayed flowering in ORYZA1 (Section 3.2.1; "Drought stress and development rate").

Carbohydrate partitioning between shoot and root under drought stress is generally altered in favor of the root biomass (Brouwer 1965, O'Toole and Chang 1979, O'Toole and Moya 1981). When leaves stop expanding, photosynthesis still continues and the level of reserve carbohydrates increases, which makes more of them available for growth of the root system (van Keulen and Seligman 1987). Hence, in ORYZA1, the effect of drought on partitioning of assimilates between shoot and root and on rooting depth is computed from the reduced leaf expansion factor (Sections 3.2.3 and 3.4).

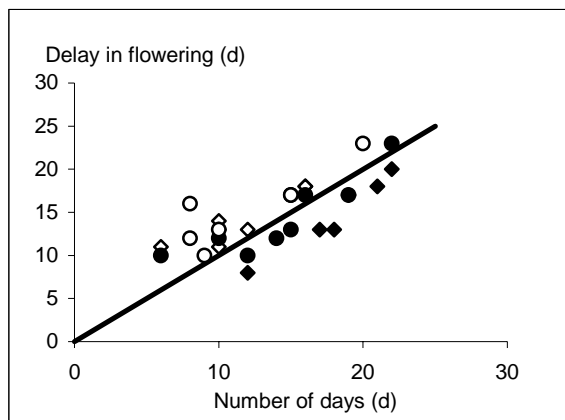

Fig 4.2. Relation between delay in flowering and the number of days between zero leaf expansion and recovery from drought. Data are from Wopereis (1996b); ♦ IR20 1992 DS, ◇ IR20 1992 WS; ● IR72 1992 DS, ○ IR72 1992 WS. The drawn line is the fitted relationship for IR20 and IR72.

4.2.3 Accelerated leaf senescence

```
!-----Relative death rate factor
LD(I) = (LOG10(MSKPA(I)+TINY)-LOG10(LLDL)) &
        / (LOG10(ULDL)-LOG10(LLDL))
LD(I) = LIMIT(0.,1.,LD(I))
LDAV = LDAV+(ZRTL/(ZRT+TINY))*LD(I)
```

Drought accelerates the senescence and death rate of leaves (Lilley and Fukai 1994). In our experiments, a so-called drought-induced dead leaf factor was monitored: a value of 1 indicated no dead leaves and a value of 0 indicated that all leaves were dead. Figure 4.3 presents the relationship between the dead leaf factor and the soil-water tension in the root zone. Leaves started dying after the soil-water tension increased above about 300 kPa (ULDL) and were fully dead at soil-water tensions of about 700 kPa (LLDL). The calculation of the drought-induced leaf death factor (LD per layer; LDAV as average over the whole rooted depth) follows the same scheme as that of the leaf-rolling factor explained above. The effect of the dead leaf factor on the simulation of the leaf death rate in ORYZA1 is explained in Section 3.2.10.

4.2.4 Relative and actual transpiration rate

```
!-----Relative transpiration ratio (actual/potential)
IF (MSKPA(I) .GE. 10000.) THEN
  TRR(I) = 0.
ELSE
```

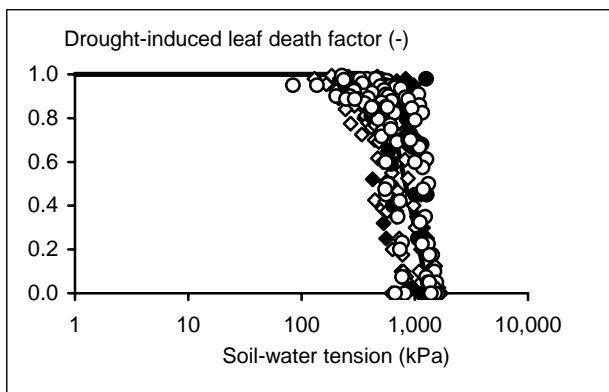

Fig. 4.3. Drought-induced leaf death factor as a function of soil-water tension. Data are from Wopereis (1996b); ♦ IR20 1992 DS, ◇ IR20 1992 WS; ● IR72 1992 DS, ○ IR72 1992 WS. The drawn line is the fitted relationship for cultivars IR20 and IR72.

```

IF (SWIRTR .EQ. 'DATA') THEN
  TRR(I) = (LOG10(MSKPA(I)+TINY)-LOG10(LLRT)) &
           / (LOG10(ULRT)-LOG10(LLRT))
  TRR(I) = LIMIT(0.,1.,TRR(I))
ELSE
  TRR(I) = 2./(1.+EXP(0.003297 * MSKPA(I)))
END IF
END IF
TRR(I) = LIMIT(0.,1.,TRR(I))
WLA(I) = MAX(0.0,(WCLQT(I)-WCWP(I))*ZRTL*1000.)
TRWL(I) = MIN(TRR(I)*ZRTL*TRRM,WLA(I)/DELT)
TRW = TRW + TRWL(I)

```

Crops under drought stress close their stomata to reduce transpiration. This increases the resistance to the gas exchange of CO₂, which decreases the rate of photosynthesis. Many authors have shown that there is a constant ratio of transpiration to gross photosynthesis under drought stress (de Wit 1958, Tanner and Sinclair 1983). This approach is adopted to reduce the gross photosynthesis rate as a function of relative transpiration ratio, which is defined as the ratio of the actual transpiration of stressed plants (T_a , TRW; mm d⁻¹) to that of well-watered plants (T_p , TRC; mm d⁻¹) (Section 3.2.2).

In our experiments, pots with well-watered and stressed plants were weighed daily (early morning) to estimate transpiration losses. The transpiration rate was calculated as the difference in pot weight between successive days. If drought stress results in a reduction in leaf area index LAI (see above), the measured potential transpiration of well-watered plants will be higher than the potential transpiration rate of stressed plants. Radiation is the main driving force for differences in transpiration between the well-watered and stressed canopies. The potential transpiration of the stressed plants was therefore calculated from the transpiration of the well-watered plants, using the ratio of the calculated absorbed fraction of global radiation in stressed and well-watered plants as a weighting factor (Wopereis et al 1996b):

$$T_{p,d} = T_{p,ww} (1 - \exp(-k \times LAI_d)) / (1 - \exp(-k \times LAI_{ww})) \quad (4.6)$$

where $T_{p,d}$ is the potential transpiration rate of stressed plants (mm d⁻¹), $T_{p,ww}$ the potential transpiration rate of well-watered plants (mm d⁻¹), LAI_d the leaf area index of stressed plants (ha leaf ha⁻¹ soil), LAI_{ww} the leaf area index of well-watered plants (ha leaf ha⁻¹ soil), and k the extinction coefficient for solar radiation, 0.5.

Figure 4.4 gives the relative transpiration ratio (T_d/T_p , TRR; -) as a function of soil-water tension. TRR starts to decrease with soil-water tensions of about 70 kPa (ULRT) and approaches 0 at soil-water tensions around 1,500 kPa (LLRT). As for the other water-stress factors, a simple linear relationship between relative transpiration ratio and the logarithmic of soil-water tension (h ,

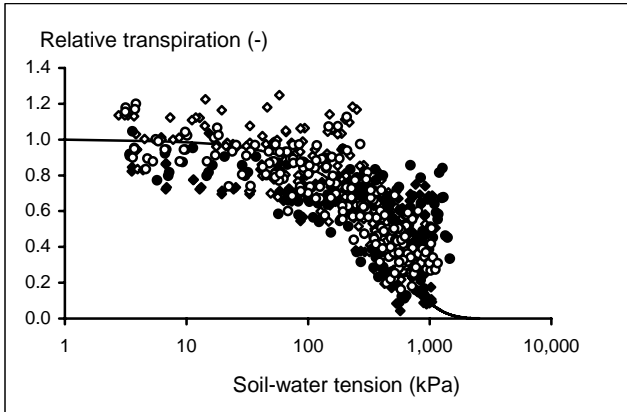

Fig. 4.4. Relative transpiration ratio as a function of soil-water tension. Data are from Wopereis (1996b); \blacklozenge IR20 1992 DS, \diamond IR20 1992 WS; \bullet IR72 1992 DS, \circ IR72 1992 WS. The drawn lines are the fitted relationships for cultivars IR20 and IR72.

MSKPA) can be fitted through the data sets, using the values for ULRT and LLRT as critical threshold points. However, a better fit is obtained with an exponential function:

$$T_a/T_p = 2 / (1 + \exp(\gamma \times h)) \quad (4.7)$$

where γ is the regression coefficient. We calculated an average value for γ of 3.297×10^{-3} . In WSTRESS, there is a user-defined option to use either the linear approach or the exponential relationship, via the variable SWIRTR as defined in the crop data file (Section 7.3). The advantage of the linear relationship is that it can easily be changed by modifying the values of ULRT and LLRT in the crop data file. The advantage of the logarithmic approach is a closer fit to reality, though the user cannot affect the shape of the relationship as easily via parameter values in the crop data file. To avoid FORTRAN computation errors, the value of TRR is set at 0 when MSKPA is higher than 10,000 kPa.

The actual transpiration rate per soil layer (T_a , TRWL; mm d⁻¹) is calculated for each soil layer as the potential transpiration rate (T_p , TRRM; mm d⁻¹ m⁻¹) times the relative transpiration ratio (TRR; -) times the rooted depth in the soil layer. The total amount of water that can be transpired is limited by the total amount of water (W , WLA; mm) that can be extracted by the roots in each soil layer. This amount is calculated from the amount of water in the profile, the minimum amount of water below which the plants permanently wilt, and the rooted depth:

$$W = (\theta - \theta_{wp}) Z_r \times 1,000 \quad (4.8)$$

where θ is the volumetric water content (WCLQT; $\text{m}^3 \text{m}^{-3}$), θ_{wp} is the volumetric water content at the wilting point (WCWP; $\text{m}^3 \text{m}^{-3}$), and Z_r is the rooting depth in the soil layer (ZRTL; m). The factor 1,000 converts m into mm values.

The total amount of water available for transpiration (WLA) is divided by the time step of integration (DELTA, which equals 1) of the model ORYZA2000 to get the maximum daily extraction rates. Finally, the total water uptake from the whole rooted profile for actual transpiration by the crop (TRW; mm d^{-1}) is obtained by summing the individual actual transpiration rates from each soil layer. The TRW is initialized at 0 at each time step before the DO-loop over the soil layers begins (see above).

4.2.5 Water uptake compensation

The above calculation of actual transpiration and water uptake per soil layer assumes that the roots are equally effective in water uptake in each soil layer. The water uptake per layer is equal to the potential uptake rate (transpiration rate) times the rooted depth in that layer times the relative uptake (transpiration) factor computed from the soil-water tension in that particular layer. If a particular layer is depleted of water, no more water uptake from that layer occurs. Roots in another layer, however, may compensate for this by increasing their water uptake (e.g., Hasegawa and Yoshida 1982). This compensation effect is taken into account in WSTRESS. Preference is given to compensation uptake from the top layers over the lower layers (Taylor and Klepper 1978).

```
!--Compensation of water extraction from soil layers if drought stress occurs
! Take water from soil layer that has a surplus, starting from top.
DO I = 1,NL
  IF (TRW .LT. TRC) THEN
    IF (TRR(I).GE.1 .AND. TRWL(I).LT.WLA(I)/DELTA) THEN
      TRWL(I) = MIN(WLA(I)/DELTA, (TRWL(I)+(TRC-TRW)/DELTA))
    END IF
    TRW = 0.
    DO J = 1,NL
      TRW = TRW + TRWL(J)
    END DO
  END IF
END DO
```

The compensation for a loss in water uptake from a certain soil layer by increased water uptake from another layer occurs only if the total actual crop transpiration calculated without compensation (TRW) is smaller than total potential crop transpiration (TRC). The compensation between soil layers stops when compensation between a certain number of layers has resulted in a total actual crop water transpiration that is equal to total potential crop transpiration.

Therefore, the comparison between actual and potential total crop transpiration is placed within a DO-loop over soil layers. Starting from the top, for each consecutive soil layer downward, the model checks whether no water stress occurs (TRR equals 1) and whether there is a surplus of extractable water (i.e., whether the daily water uptake from that layer, TRWL, is smaller than the daily amount of extractable water, WLA/DELTA). If there is a surplus of extractable water, the water uptake from that particular layer increases to the minimum of the amount of extractable water from that layer and the deficit in crop transpiration rate (i.e., total potential minus actual crop transpiration). After this readjustment of water uptake from that particular layer, a second DO-loop over water uptake sums the total water uptakes from all soil layers again to get a new value of total actual water uptake (transpiration) rate (TRW). This actual transpiration rate is then compared with the potential transpiration rate at a new iteration of the DO-loop over soil layers to see whether compensation among more soil layers is necessary.

4.2.6 Relative photosynthesis rate

$$\text{PCEW} = \text{NOTNUL}(\text{TRW}/\text{TRC})$$

After readjustment of water uptake from soil layers, the photosynthesis reduction factor (PCEW; -) is calculated as the ratio of the actual transpiration (T_a , TRW; mm d^{-1}) to that of potential transpiration (T_p , TRC; mm d^{-1}). The statement NOTNUL is used to avoid arithmetic errors in the calculation when TRC equals 0 (in that case, a zero value is returned). Section 3.2.2 (“Gross CO₂ assimilation and light absorption”) explains the effect of the photosynthesis reduction factor on the simulation of canopy photosynthesis in ORYZA1.

4.2.7 Terminal section

```
!-----Set stress factors as average over all layers: DEFAULT
      LRSTRS = LRAV
      LDSTRS = LDAV
      LESTRS = LEAV
```

The calculated stress factors for leaf rolling, accelerated leaf death, and decreased leaf expansion are renamed for communication with ORYZA1 (LRSTRS, LDSTRS, and LESTRS, respectively).

```
!-----If crop is not in the main field, set all stress factors at 1.
      ELSE
        PCEW   = 1.
        LRSTRS = 1.
        LDSTRS = 1.
```



```

    LESTRS = 1.
END IF

```

When the crop is transplanted, it is assumed that there is no drought stress in the seedbed and that all stress factors are set at unity (indicating no stress).

```

!-----Output writing only when crop is in main field
  IF (OUTPUT) THEN
    IF (CROPSTA .GE.4) THEN
      CALL OUTDAT (2, 0, 'MSKPA1', MSKPA1)
      .....
    END IF
  END IF
END IF
END IF
RETURN
END

```

At the end of the rate calculation section, output is written to the output data file, for example, 'CALL OUTDAT (2, 0, 'MSKPA1', MSKPA1)', using the write routines of the TTUTIL library (Section 2.4.2).

4.3 Non-water-limited growth

```

SUBROUTINE WNSTRESS (NL, TRW, TRWL, LRSTRS, LDSTRS, LESTRS, PCEW)

```

The subroutine WNSTRESS is called in ORYZA2000 instead of the subroutine WSTRESS described above when the crop model is run without a water balance (potential production). After parameter declaration, the subroutine sets actual transpiration rates at 0 and all drought stress factors at unity.

```

  TRW    = 0.
  LRSTRS = 1.
  LDSTRS = 1.
  LESTRS = 1.
  PCEW   = 1.
  DO I=1,NL
    TRWL(I) = 0.
  END DO

```

5 Nitrogen dynamics

The crop-soil nitrogen (N) dynamics are simulated with two subroutines, NCROP and NSOIL. NCROP calculates crop N demand, uptake, distribution, and translocation in the canopy and computes stress factors for growth and development caused by N limitations. NSOIL tracks the daily N availability in the soil. Both subroutines are called in ORYZA2000 when the user-defined parameter NITROENV is set at 'NITROGEN BALANCE' in the experimental data file (Section 7.2). The level of N stress that a rice crop experiences depends on the availability of N for uptake from the soil. In NSOIL, this availability is computed as the sum of indigenous soil supply and fertilizer supply. If there is ample fertilizer N, the crop does not experience N limitations and the production situation is potential. The potential production simulated is then determined by the leaf N concentration as calculated in NCROP. Another way to estimate potential production is to run ORYZA2000 with NITROENV = 'POTENTIAL'. In this case, no N dynamics are calculated and subroutine NNOSTRESS is called. All N stress factors are kept at unity and the leaf N concentration is read from the crop data file (Section 7.3). This leaf N concentration is an empirical value to be derived from field experimentation and is not necessarily the same as what would be calculated using NCROP for a particular experiment under an ample N supply. Therefore, crop growth and development simulated under potential production situations (NITROENV = 'POTENTIAL') can be different from those simulated with an ample supply of N fertilizer with an N balance (NITROENV = 'NITROGEN BALANCE').

All three subroutines, NCROP, NSOIL, and NNOSTRESS, are called from the subroutine MODELS of ORYZA2000 (Section 2.2.2) and are divided into sections for initialization, rate calculations, state integrations, and terminal calculations. In the initialization section, all model state and rate variables are given an initial value (generally 0) and model parameters are read from the data files. Except for specific conditions, this initialization section is not further detailed in the explanations below.

5.1 Crop nitrogen dynamics

```
SUBROUTINE NCROP (ITASK, IUNITD, IUNITL, FILEI1, DELT, TIME, OUTPUT, &  
                TERMNL, DVS, LLV, DLDR, WLVG, WST, WSO, GSO, GST, GLV, &  
                PLTR, LAI, CROPSTA, TNSOIL, NACR, NFLV, NSLLV, RNSTRS)
```

NCROP first calculates the daily potential demand for N by the various plant organs based on their weights, growth rates, and maximum N content. Next, the amount of N that can be translocated daily from the leaves, stems, and roots to the storage organs is computed. This amount of daily "translocatable" N is

subtracted from the daily potential demand to get the daily potential demand for uptake from the soil. This potential uptake demand is limited by the daily extractable amount of N from the soil and the maximum uptake rate of the crop. The amount of N that can be taken up is then distributed to the various plant organs on the basis of their relative demands for N. At the end of a time step, all calculated N flows (uptake from soil, and translocation) are integrated into total amounts of N in the plant organs and the whole crop. Nitrogen stress factors for growth and development are calculated (and passed on to the model ORYZA1 through the subroutine MODELS).

The N dynamics are calculated only for the aboveground crop parts. The roots act as a source of N via translocation, but no root N uptake is simulated.

```
!-----Initialization
      IF (ITASK.EQ.1) THEN
!       Initialize variables
      NUPP = 0.
      ANLV = 0.
      ANSO = 0.
      .....
      FNLV = FNLVI
      FNST = 0.5*FNLVI
      NFLV = NFLVI
      NSLLV = 1.
      RNSTRS = 1.

!====Rate calculations
      ELSE IF (ITASK.EQ.2) THEN
!===== Only calculations after sowing
      IF (CROPSTA .GE. 4) THEN
        <Rate calculations>
```

Besides initializing state and rate variables at zero, the fraction of N in the leaves (FNLV; kg N kg⁻¹ leaf, and NFLV; g N m⁻² leaf) is given an initial value as read from the crop data file and the N stress factors (NSLLV, RNSTRS; see below) are set at unity (meaning no effect on crop growth in ORYZA1). After parameter declarations and initialization, the rate calculations are given (ITASK.EQ.2). These are done only with crop growth in the main field (CROPSTA.GE.4), that is, after transplanting for transplanted crops and after emergence for direct-seeded crops.

5.1.1 Nitrogen demand by crop organs

```
!----- Linear interpolation of parameter values
      NMINSO = LINT2('NMINSO',NMINSO,ILNMNS,ANCRF)
      NMAXL = LINT2('NMAXLT',NMAXLT,ILNMAX,DVS)
      NMINL = LINT2('NMINLT',NMINLT,ILNMIN,DVS)
```

```

!      Potential leaf N content (on LAI basis)
      NFLVP = LINT2('NFLVTB',NFLVTB,ILNFLV,DVS)

!===== Calculate (potential) N demand of crop organs
!      Maximum N demand of leaves

      NDEML = (NMAXL*(WLVG+GLV*DELTA)-ANLV)/DELTA
      IF (NDEML .LT. 0.) NDEML = 0.

!      Maximum N demand of stems
      NDEMS = (NMAXL*0.5*(WST+GST*DELTA)-ANST)/DELTA
      IF (NDEMS .LT. 0.) NDEMS = 0.

!      Maximum N demand of storage organs
      NDEMSX = NMAXSO*GSO
      IF (NDEMSX .LT. 0.) NDEMSX = 0.

!      Minimum N demand of storage organs
      NDEMSN = NMINSO*GSO
      IF (NDEMSN .LT. 0.) NDEMSN = 0.

```

First, the potential (maximum) and minimum N demand of the crop organs are calculated. The basic assumption is that the crop strives to maintain the nitrogen content in its organs close to the potential values (Drenth et al 1994). The maximum N demand of leaves ($ND_{mx,lv}$, NDEML; kg N ha⁻¹ d⁻¹) is calculated from the difference between the potential and actual (NA_{lv} , ANLV; kg N ha⁻¹) amount of N divided by the time step of integration. The potential amount of N is calculated from the weight (W_{lv} , WLVG; kg dry matter ha⁻¹) plus the growth rate of leaves (GW_{lv} , WLVG; kg dry matter ha⁻¹ d⁻¹) over the time step (δt), times the maximum N content ($NC_{mx,lv}$, NMAXL; kg N kg⁻¹ dry matter):

$$ND_{mx,lv} = (NC_{mx,lv} (W_{lv} + GW_{lv} \delta t) - NA_{lv}) / \delta t \quad (5.1)$$

The maximum as well as the minimum N content in the leaves change with the development of the crop (Fig. 5.1). The highest value is found at the beginning of the growing period, after which the concentration goes down with crop development. The maximum and minimum N content of the leaves are read as tables (NMAXLT and NMINLT, respectively) from the crop data file (in the initialization section of the model), and daily interpolated values are obtained as a function of development stage using the function LINT2.

Drenth et al (1994) found a linear relationship between the N content in the stems ($NC_{mx,st}$, NMAXS; kg N kg⁻¹ dry matter) and that in the leaves from experimental data, covering different locations, varieties, and nitrogen treatments (Fig. 5.2). The stem N content is half the leaf N content across growing stages. Thus, the maximum stem N demand ($ND_{mx,st}$, NDEMS; kg N ha⁻¹ d⁻¹) is calculated from the maximum N content in the leaves and the weight (W_{st} , WST; kg dry matter ha⁻¹), growth rate (GW_{st} ; kg dry matter ha⁻¹ d⁻¹), and actual amount of N (NA_{st} , ANST; kg N ha⁻¹) of the stems:

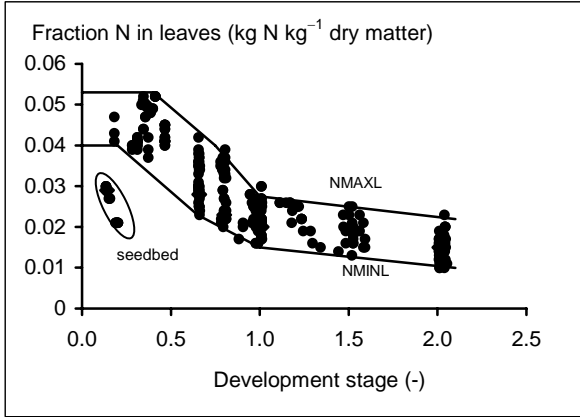

Fig. 5.1. Mass fraction (kg N kg^{-1} dry matter) of N in leaves as a function of development stage. Data derived from experiments carried out at IIRRI (Philippines, wet and dry seasons 1991-93). The solid lines represent the minimum and maximum nitrogen content of the leaves as defined in the tables NMINLT and NMAXLT.

$$ND_{\text{mx,st}} = (0.5 NC_{\text{mx,lv}} (W_{\text{st}} + GW_{\text{st}} \delta t) - NA_{\text{st}}) / \delta t \quad (5.2)$$

The maximum content of N in the storage organs ($NC_{\text{mx,so}}$, NMAXSO; kg N kg^{-1} dry matter) is a single value, independent of development stage, and the maximum N demand of the storage organs ($ND_{\text{mx,so}}$, NDEMSX; $\text{kg N ha}^{-1} \text{d}^{-1}$) is simply calculated from the maximum N content and the daily growth rate (GW_{so} , GSO; $\text{kg dry matter ha}^{-1} \text{d}^{-1}$):

$$ND_{\text{mx,so}} = NC_{\text{mx,so}} GW_{\text{so}} \quad (5.3)$$

Drenth et al (1994) derived a value of $0.0175 \text{ kg N kg}^{-1}$ dry matter for NMAXSO (see also Fig. 5.3). The minimum content of N in the storage organs ($NC_{\text{mn,so}}$, NMINSO; kg N kg^{-1} dry matter) is determined by the amount of N in the crop at the moment of flowering (ANCRF; kg N ha^{-1}). After flowering, part of this N is reallocated to the storage organs. Figure 5.3 shows the relationship between the N content in the storage organs at harvest and ANCRF. These data include only experiments and treatments in which no postflowering N application occurred. The drawn line is the empirical relationship read from the crop data file in the table NMINSO, which is linearly interpolated to get daily values of NMINSO using the function LINT2 of the library TTUTIL (Section 2.4.1). Postflowering N uptake may augment this base value, up to a maximum of $0.0175 \text{ kg N kg}^{-1}$ dry matter (NMAXSO). $NC_{\text{mn,so}}$ (NMINSO) is used to calculate the minimum N demand of the storage organs ($ND_{\text{mn,so}}$, NDEMSN; $\text{kg N ha}^{-1} \text{d}^{-1}$):

$$ND_{\text{mn,so}} = NC_{\text{mn,so}} GW_{\text{so}} \quad (5.4)$$

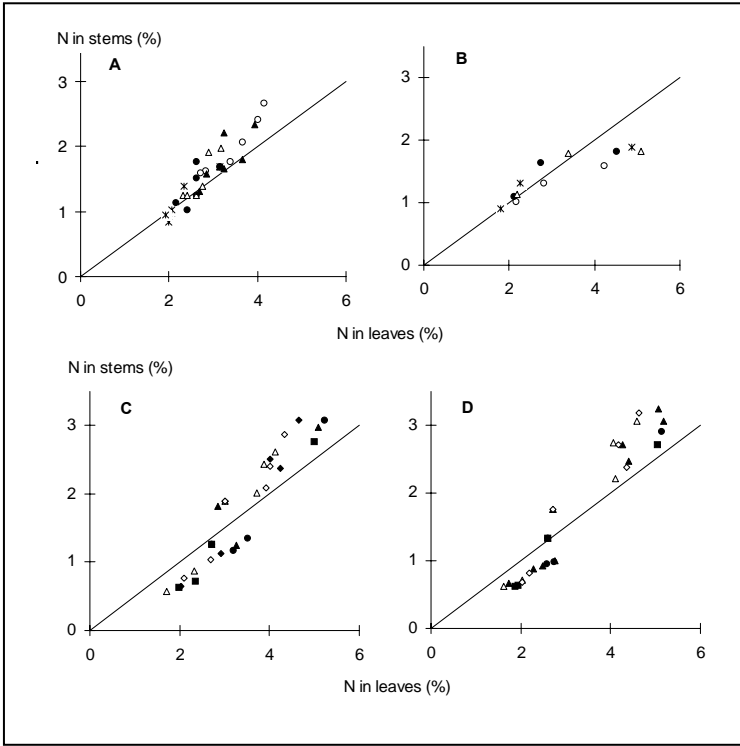

Fig. 5.2. Mass fraction of N in stems as a function of the mass fraction of N in the leaves (kg N kg^{-1} dry matter). Data derived from experiments carried out at (A) TNAU-TNRRI, India, wet season 1988-89; (B) CRRI, India, dry season 1990; (C) and (D) IRRI, Philippines, wet season 1991 and dry season 1992. The symbols indicate different N treatments; the fitted line has a slope of 0.5 (Drenth et al 1994).

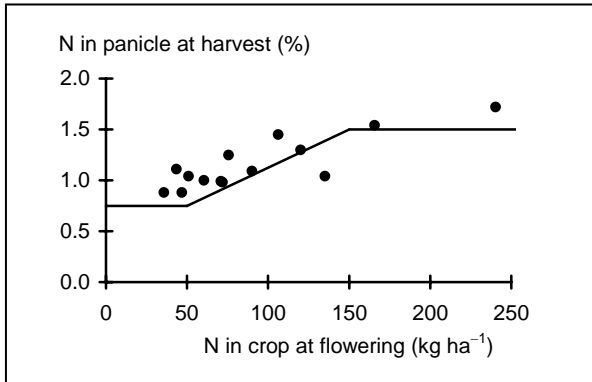

Fig. 5.3. Mass fraction (kg N kg^{-1} dry matter) of N in the panicle at harvest as a function of the amount of N in the crop (kg ha^{-1}) at flowering. The dots (●) represent data from experiments carried out at IRRI (Philippines, wet season 1991), CRRI (India, dry season 1990), and TNAU-TNRRI (India, wet season 1988-89). The solid line is the fitted relationship (Drenth et al 1994).

5.1.2 Nitrogen translocation

```

!===== Calculate translocation of N from organs, in kg/ha/d
!           No translocation before DVS = 0.95
           IF (DVS .LT. 0.95) THEN
               ATNLV = 0.
               ATNST = 0.
               ATN   = 0.
               NTSO = 0.
           ELSE
!           Maximum translocation amount from leaves and stems
               ATNLV = MAX(0., ANLV-WLVG*RFNLV)
               ATNST = MAX(0., ANST-WST*RFNST)
!           Maximum translocation amount from roots as fraction of that of shoots
               ATNRT = (ATNLV+ATNST)*FNTRT
               ATN   = ATNLV+ATNST+ATNRT
!           Daily translocation to storage organs is total pool divided by time
!           constant
               NTSO = ATN/TCNTRF
!           Translocation is limited between minimum (NDEMSN) and maximum
!           (NDEMSX)
               NTSO = LIMIT(NDEMSN,NDEMSX,NTSO)
           END IF
!----- Actual N translocation rates from plant organs, in kg/ha/d
           NTLV  = NTSO*ATNLV/NOTNUL(ATN)
           NTST  = NTSO*ATNST/NOTNUL(ATN)
           NTRT  = NTSO*ATNRT/NOTNUL(ATN)

```

All the N allocated to the storage organs ($NSUPSO$; $\text{kg N ha}^{-1} \text{ d}^{-1}$) is supplied by translocation from leaves, stems, and roots. Translocation starts only when storage organs are formed (at development stage 0.95), so, before this time, their values are set at 0. For leaves and stems, the daily maximum “translocatable” amounts of N ($NT_{\text{mx,lv}}$, $ATNLV$, for leaves, and $NT_{\text{mx,st}}$, $ATNST$, for stems; kg N ha^{-1}) are determined from the total amount of N in the organ (NA_{lv} , $ANLV$, for leaves, and NA_{st} , $ANST$, for stems; kg N ha^{-1}) minus the residual content of N at harvest (NR_{lv} , $RFNLV$, for leaves, and NR_{st} , $RFNST$, for stems; kg N kg^{-1} dry matter) times the weight of the organ (W_{lv} , $WLVG$, for leaves, and W_{st} , WST , for stems; $\text{kg dry matter ha}^{-1}$):

$$NT_{\text{mx,lv}} = NA_{\text{lv}} - W_{\text{lv}} NR_{\text{lv}} \quad (5.5)$$

$$NT_{\text{mx,st}} = NA_{\text{st}} - W_{\text{st}} NR_{\text{st}} \quad (5.6)$$

For leaves, $RFNLV$ is $0.004 \text{ kg N kg}^{-1}$ dry matter (see Fig. 5.1); for stems, it is $0.0015 \text{ kg N kg}^{-1}$ dry matter.

Since no N balance for roots is modeled in NCROP, it is estimated that the maximum amount of N translocated from roots ($NT_{mx,rt}$, ATNRT) is a fraction ($NTF_{mx,rt}$, FNTRT; 0.15) of the maximum amount of N translocated from leaves and stems combined (P.K. Aggarwal, personal communication):

$$NT_{mx,rt} = NTF_{mx,rt} (NT_{mx,lv} + NT_{mx,st}) \quad (5.7)$$

All potential translocatable N is summed and divided by a time coefficient (TCNT; d) for translocation (set at 10 days) to obtain the daily rates of potential translocation to the storage organs, NUSUPSO. This potential translocation rate is limited by the maximum (NDEMSX) and minimum (NDEMSEN) N demand of the storage organs calculated earlier (Section 5.1.1) to obtain the actual daily rate of N translocation ($NT_{a,so}$, NTSO). This actual N translocation rate is then divided back again into actual N translocation rates from the leaves ($NT_{a,lv}$, NTLV), stems ($NT_{a,st}$, NTST), and roots ($NT_{a,rt}$, NTRT) (all in $\text{kg N ha}^{-1} \text{d}^{-1}$).

5.1.3 Nitrogen uptake

```
! Available N uptake is minimum of soil supply and maximum of crop uptake
  NUPP = MIN(NMAXUP, TNSOIL)
  IF (NUPP .LT. 0.) NUPP = 0.
! Sum of total potential N demand from leaves, stems, and storage organs
  NDEMC = (NDEML+NTLV)+(NDEMS+NTST)+(NDEMSX-NTSO)
! Actual uptake per plant organ is minimum of availability and demand
  NALV = MAX(0.,MIN(NDEML+NTLV, &
    NUPP*((NDEML+NTLV)/NOTNUL(NDEMC))))
  NAST = MAX(0.,MIN(NDEMS+NTST, &
    NUPP*((NDEMS+NTST)/NOTNUL(NDEMC))))
  NASO = MAX(0.,MIN(NDEMSX-NTSO, &
    NUPP*((NDEMSX-NTSO)/NOTNUL(NDEMC))))
! Total uptake by crop from the soil
  NACR = NALV+NAST+NASO
```

Rice plants are physiologically limited in the daily amount of N they can take up (NMAXUP; $\text{kg N ha}^{-1} \text{d}^{-1}$). So far, the highest reported N uptake rates for rice grown in tropical or temperate climates are about $6 \text{ kg ha}^{-1} \text{d}^{-1}$ (Takahashi 1975, Setter et al 1994). However, these data were mostly derived from measurements of N uptake over a period of 7 to 14 d. Recently, however, Peng and Cassman (1998) observed N uptake in tropical rice at IRRI on a 2-d basis and calculated that maximum N uptake rates at panicle initiation were as high as $9\text{--}12 \text{ kg ha}^{-1} \text{d}^{-1}$. In our model, we set the average maximum N uptake rate by the crop at $8 \text{ kg ha}^{-1} \text{d}^{-1}$ (however, this parameter is user-supplied in the crop data file and can be changed by the user, Section 7.3). The maximum amount of N that can be taken up and that is available for crop growth (NUPP) is the

minimum of NMAXUP and the amount that is supplied by the soil (TNSOIL; indigenous N supply plus any fertilizer N; $\text{kg N ha}^{-1} \text{d}^{-1}$). The N supplied by the soil is calculated in the subroutine NSOIL (Section 5.2) and passed on to the subroutine NCROP.

The daily potential N demand (for uptake from the soil) by the crop is the sum of the potential N demand of the individual organs. The potential N demand of the leaves and stems is the potential N demand of those organs plus the actual translocation from those organs into the storage organs. The potential N demand of the storage organs is met partly or wholly by translocation:

$$ND_{\text{mx,c}} = (ND_{\text{mx,lv}} + NT_{\text{a,lv}}) + (ND_{\text{mx,st}} + NT_{\text{a,st}}) + (ND_{\text{mx,so}} - NT_{\text{a,so}}) \quad (5.8)$$

where $ND_{\text{mx,c}}$ is the maximum daily N demand of the whole crop (NDEMC; $\text{kg N ha}^{-1} \text{d}^{-1}$), $ND_{\text{mx,lv}}$ is the maximum daily N demand of the leaves (NDEML; $\text{kg N ha}^{-1} \text{d}^{-1}$), $ND_{\text{mx,st}}$ is the maximum daily N demand of the stems (NDEMS; $\text{kg N ha}^{-1} \text{d}^{-1}$), $ND_{\text{mx,so}}$ is the maximum daily N demand of the storage organs (NDEM SX; $\text{kg N ha}^{-1} \text{d}^{-1}$), $NT_{\text{a,lv}}$ is the actual daily rate of N translocation from the leaves (NTLV; $\text{kg N ha}^{-1} \text{d}^{-1}$), $NT_{\text{a,st}}$ is the actual daily rate of N translocation from the stems (NTST; $\text{kg N ha}^{-1} \text{d}^{-1}$), and $NT_{\text{a,so}}$ is the actual daily rate of N translocation into the storage organs (NTSO; $\text{kg N ha}^{-1} \text{d}^{-1}$).

The actual N uptake rate of each organ (NU_{lv} , NALV, for leaves, NU_{st} , NAST, for stems, NU_{so} , NASO, for storage organs; $\text{kg N ha}^{-1} \text{d}^{-1}$) is then calculated as the weighted fraction of the minimum of the available N for uptake (NUPP) and the total crop N demand (NDEMC). The weighting fraction is the potential N demand of each organ over the potential N demand of the whole crop. The actual N uptake rate of the whole crop (NU_{c} , NACR; $\text{kg N ha}^{-1} \text{d}^{-1}$) is calculated as the sum of the N uptake rates of the (aboveground) crop organs:

$$NU_{\text{c}} = NU_{\text{lv}} + NU_{\text{st}} + NU_{\text{so}} \quad (5.9)$$

5.1.4 Nitrogen in the crop

```
!===== Calculate net N flows to plant organs (daily rates)
!       Transplanting shock: remove N
        NSHKLV =ANLV*(1.-PLTR)
        NSHKST =ANST*(1.-PLTR)
!       Loss of N from leaves by leaf death
        NLDLV = (LLV+DLDR)*RFNLV
!----- Net flow to stems and leaves
        NLV = NALV-NTLV-NLDLV-NSHKLV
        NST = NAST-NTST-NSHKST
!----- Net N flow to storage organs
        NSO = NTSO+NASO
```

```

!----- Net flow to stems and leaves before flowering
      IF (DVS.LT. 1.) THEN
          NSTAN =NST
          NLVAN =NLV
      ELSE
          NSTAN = 0.
          NLVAN = 0.
      END IF

```

After uptake, the actual N flows to and from the crop organs are calculated. First, the effect of transplanting is incorporated as a negative flow rate of N from the leaves (NSHKL_V; kg N ha⁻¹ d⁻¹) and stems (NSHKST; kg N ha⁻¹ d⁻¹) on the day of transplanting caused by dilution. The dilution parameter (PLTR) was calculated by Eqn. 3.29 in the model ORYZA1 (Section 3.2.7).

Besides translocation, N is lost from the pool in the leaves through dying and falling off of leaves. This N loss rate (NL_{DLV}; kg N ha⁻¹ d⁻¹) is calculated from the death rate of leaves times the fraction of residual N in the dead leaves (RFNLV). The death rate of leaves was calculated in ORYZA1 and consists of the “regular” death caused by senescence (LLV; kg dry matter ha⁻¹ d⁻¹) (Section 3.2.4) and the drought-induced death rate caused by drought, if any (DLDR; kg dry matter ha⁻¹ d⁻¹) (Section 3.2.10).

The daily net flow of N to the leaves is the sum of the N uptake rate from the soil minus the translocation to the storage organs, the losses caused by leaf death, and dilution at transplanting:

$$NF_{lv} = NU_{lv} - NT_{a,lv} - NL_{lv} - ND_{lv} \quad (5.10)$$

where NF_{lv} is the daily net flow rate of N to the leaves (NL_V; kg N ha⁻¹ d⁻¹), NU_{lv} is the actual daily N uptake rate from the soil by the leaves (NAL_V; kg N ha⁻¹ d⁻¹), $NT_{a,lv}$ is the daily translocation rate of N from the leaves (NTL_V; kg N ha⁻¹ d⁻¹), NL_{lv} is the daily loss rate of leaf N by leaf death (NL_{DLV}; kg N ha⁻¹ d⁻¹), and ND_{lv} is the loss of leaf N caused by dilution at transplanting (NSHKL_V; kg N ha⁻¹ d⁻¹).

The daily net flow of N to the stems follows the same calculation as that for the leaves except that there is no loss by stem death and falling off:

$$NF_{st} = NU_{st} - NT_{a,st} - ND_{lv} \quad (5.11)$$

where NF_{st} is the daily net flow rate of N to the stems (NST; kg N ha⁻¹ d⁻¹), NU_{st} is the actual daily N uptake rate from the soil by the stems (NAST; kg N ha⁻¹ d⁻¹), $NT_{a,st}$ is the daily translocation rate of N from the stems (NTST; kg N ha⁻¹ d⁻¹), and ND_{st} is the loss of stem N caused by dilution at transplanting (NSHKST; kg N ha⁻¹ d⁻¹).

The daily net flow of N to the storage organs is the total N translocation from the leaves, stems, and roots plus additional uptake from the soil:

$$NF_{so} = NU_{so} + NT_{a,so} \quad (5.12)$$

where NF_{so} is the daily net flow rate of N to the storage organs (NSO; kg N ha⁻¹ d⁻¹), NU_{so} is the daily N uptake rate from the soil by the storage organs (NASO; kg N ha⁻¹ d⁻¹), and $NT_{a,so}$ is the daily translocation rate of N into the storage organs (NTSO; kg N ha⁻¹ d⁻¹).

To track the amount of N in the crop before flowering (for the calculation of ANCRF, see above), the net flows of N to the leaves (NLVAN; kg N ha⁻¹ d⁻¹) and stems (NSTAN; kg N ha⁻¹ d⁻¹) before flowering are tracked separately.

```

!====State updates/integration
      ELSE IF (ITASK.EQ.3) THEN

!----- N amount in plant organs
      ANSO =INTGRL(ANSO,NSO, DELT)
      ANLV =INTGRL(ANLV,NLV,DELT)
      ANST =INTGRL(ANST,NST,DELT)
      ANLD =INTGRL(ANLD,NLDLV,DELT)
      ANCR =ANSO+ANLV+ANLD+ANST

!----- N amount in plant organs before flowering
      ANLVA =INTGRL(ANLVA,NLVAN,DELT)
      ANSTA =INTGRL(ANSTA ,NSTAN,DELT)
      ANCRF =ANSTA+ANLVA

!----- Total N uptake from soil
      NALVS = INTGRL(NALVS, NALV, DELT)
      NASTS = INTGRL(NASTS, NAST, DELT)
      NASOS = INTGRL(NASOS, NASO, DELT)
      NACRS = NALVS+NASTS+NASOS

!----- Total N supply by translocation from roots
      NTRTS = INTGRL(NTRTS, NTRT, DELT)

```

The total amounts of N in the crop organs and the total amounts of N taken up by the crop organs from the soil are calculated by integration of the daily flow rates in the integral section of NCROP (ITASK.EQ.3).

5.1.5 Nitrogen stress effects

The N status of the crop affects several growth processes. In NCROP, three effects are computed: the effect of leaf N content on photosynthesis (1) and on the relative growth rate of leaves (2) and the effect of the amount of N in the crop on the leaf death rate (3). For transplanted rice, it is assumed that no N limitations occur during the seedbed period (CROPSTA .LT. 4), and the N content in the leaves and the N stress factors are kept at their initialization values (indicating no stress and potential growth conditions).

Effect on photosynthesis

```

!----- Fraction of N in plant organs
      FNLV  =ANLV/NOTNUL(WLVG)
      FNST  =ANST/NOTNUL(WST)
      FNSO  =ANSO/NOTNUL(WSO)
!
      Leaf N content in g N m-2 leaf
      IF (LAI .EQ. 0.) THEN
          NFLV = NFLVI
      ELSE
          IF (LAI .LT.1. .AND. DVS .LT.1.) THEN
              NFLV = (FNLV/NMAXL)*NFLVP
          ELSE
              NFLV = ANLV/(10.*LAI)
          END IF
      END IF

```

First, the N content in leaves (NC_{lv} , FNLV), stems (NC_{st} , FNST), and storage organs (NC_{so} , FNSO) is calculated on a weight basis (kg N kg⁻¹ dry matter) by dividing the total amounts of N in these organs by their dry weights (WLVG, WST, and WSO, respectively). Leaf photosynthesis, however, is determined by the N content of the leaves expressed on a leaf area basis (Section 3.2.2; “Maximum leaf photosynthesis rate”) (CN_{lv} , NFLV; g N m⁻² leaf). In principle, CN_{lv} can be calculated by dividing the amount of N in the leaves (NA_{lv} , ANLV; kg N ha⁻¹ soil) by the leaf area index (LAI , LAI; ha leaf ha⁻¹ soil):

$$CN_{lv} = NA_{lv} / 10 LAI \quad (5.13)$$

The LAI is obtained from the growth model ORYZA1 and multiplied by 10 to account for the conversion of units. However, there is a complication in this calculation under conditions of N stress because of the effect of leaf N content on canopy photosynthesis. When photosynthesis decreases because of a low leaf N content, the growth rate of leaves decreases as well. Since leaf N demand is calculated from leaf weight (increase), there is a strong feedback between leaf weight and leaf N content on a weight basis. In the period of linear leaf growth, the LAI is calculated from the dry weight of leaves and the specific leaf area (Section 3.2.9). Thus, there is a feedback of leaf weight (through reduced photosynthesis) on LAI. In this stage, NFLV can simply be calculated by dividing ANLV by LAI (Eqn. 5.13). However, in the exponential phase of growth, the LAI is calculated from temperature and the relative leaf growth rate (RGRL) (Section 3.2.9). Although the RGRL is affected by N limitations as well (see below), there is no direct feedback between leaf weight and LAI. If we were to calculate NFLV by dividing ANLV by LAI following Eqn. 5.13, we would underestimate NFLV under conditions of N limitation. Therefore, during the period of exponential leaf growth, NFLV (CN_{lv}) is calculated from FNLV (NC_{lv}) by assuming that the ratio of actual to potential

leaf N content is the same on a leaf weight basis as on a leaf area basis:

$$CN_{lv} = (NC_{lv}/NC_{mx,lv}) CN_{mx,lv} \quad (5.14)$$

where $NC_{mx,lv}$ is the maximum N content on a leaf weight basis (NMAXL; kg N kg⁻¹ dry matter) and $CN_{mx,lv}$ is the maximum N content on a leaf area basis (NFLVP; g N m⁻² leaf). The maximum N content of leaves on a leaf area basis was read as a table (NFLVTB) from the crop data input file (in the initialization section of the model), and daily interpolated values were obtained as a function of development stage using the function LINT2 at the start of the rate calculation section (Section 5.1.1).

The calculated NFLV is used in ORYZA1 in the photosynthesis subroutine GPPARGET as explained in Section 3.2.2 (“Maximum leaf photosynthesis rate”).

Effect on relative growth rate of leaves

```
!----- Set N stress factor for RGRL
RNSTRS = (FNLV-0.9*NMAXL)/(NMAXL-0.9*NMAXL)
IF (RNSTRS .GT. 1.) RNSTRS = 1.
IF (RNSTRS .LT. 0.) RNSTRS = 0.
```

Without N limitations, leaf area development in the early phase of crop growth is not limited by the amount of available assimilates but mainly driven by temperature. In ORYZA1, the LAI is calculated from temperature and the relative leaf growth rate (RGRL) (Section 3.2.9). With N limitations, however, assimilates may be in short supply during the exponential phase of growth as well. On the basis of data from various N experiments at the IIRI farm, we found a maximum RGRL value of 0.0085 °Cd⁻¹ with no N limitations and 0.0045 °Cd⁻¹ without N fertilizer. The minimum value of RGRL occurred when the N content in the leaves (NC_{lv} , FNLV; kg N kg⁻¹ dry matter) dropped to 90% of the maximum value ($NC_{mx,lv}$, NMAXL). Therefore, a reduction factor for relative leaf area growth (RGRL), called $F_{n,rgrl}$ (RNSTRS; -), is calculated by scaling the actual FNLV between its maximum (NMAXL) and 90% of this maximum:

$$F_{n,rgrl} = (NC_{lv} - 0.9 NC_{mx,lv}) / (NC_{mx,lv} - 0.9 NC_{mx,lv}) \quad (5.15)$$

The value of RNSTRS is bound between 1 (when $NC_{lv} = NC_{mx,lv}$) and 0 (when $NC_{lv} = 0.9 NC_{mx,lv}$). The use of RNSTRS in the calculation of the value of RGRL under N limitations is explained in Section 3.2.9.

Effect on leaf death rate

```
!----- Set N stress factor for leaf death
ANCRPT =WLVG*NMAXL+WST*NMAXL*0.5+WSO*NMAXSO
IF (ANCR .EQ. 0.) THEN
```

```

        NSTRES = 2.
ELSE
        NSTRES = ANCRPT/ANCR
END IF
IF (NSTRES .LT. 1.) NSTRES = 1.
IF (NSTRES .GT. 2.) NSTRES = 2.
NSLLV = LINT2('NSLLVT', NSLLVT, INSLLV, NSTRES)

```

The loss rate of leaves is affected by the nitrogen status of the crop. A so-called N stress factor that accelerates leaf death (NSLLV; -) is computed that expresses the increase in leaf death as a function of N deficiency in the crop. First, a factor $F_{n,llv}$ (NSTRES; -) is calculated as the ratio of the maximum (or potential) amount of N in the crop ($NA_{mx,cr}$, ANCRPT; kg N ha⁻¹) to the actual amount of N in the crop (NA_{cr} , ANCR; kg N ha⁻¹):

$$F_{n,llv} = NA_{mx,cr}/NA_{cr} \quad (5.16)$$

The $NA_{mx,cr}$ is calculated from the actual weights of the plant organs times their maximum N contents. Aggarwal (personal communication) found that the leaf death rate was unaffected when NSTRES was 1.1 and increased by 50% when NSTRES increased to or surpassed 2. The factor NSLLV is calculated from linear interpolation of NSTRES among the values stored in the table NSLLVT (read from the crop data file in the initialization section of NCROP) using the linear interpolation function LINT2. The use of NSLLV as an increase factor for leaf death rate in ORYZA1 is explained in Section 3.2.4.

5.1.6 Simulation run check

```

!===== Termination of simulation when there is too little N in leaves
IF (LAI .GT. 1. .AND. FNLV .LE. 0.5*NMINL) THEN
    WRITE(*,*) 'Leaf N < 0.5*MINIMUM; simulation stopped'
    CALL OUTCOM('Leaf N < 0.5*MINIMUM; simulation stopped')
    TERMNL = .TRUE.
END IF

```

A check is performed during simulation on the minimum N content in the leaves: the model is stopped when the simulated N content drops below 50% of the minimum value (NMINL), which was read as a table from the crop data input file and interpolated daily at the start of the rate calculation section (Section 5.1.1). The FSE system (Chapter 2) stops the simulation run with an error message and closes all input and output files. The 50% value is arbitrarily chosen since we did not have N content measurements of crops close to dying.

5.1.7 Nitrogen balance check

```

!----- Nitrogen balance check

```

```

NCHCK = ANCR - (NACRS+NTRTS)
CALL SUBNBC (ANCR,(NACRS+NTRTS),TIME,NBCHK,TERMNL)

SUBROUTINE SUBNBC (CHKIN,CKCFL,TIME,NBCHK,TERMNL)
NBCHK = 2.0*(CHKIN-CKCFL)/(CHKIN+CKCFL+1.E-10)
IF (ABS(NBCHK).GT.0.001) THEN
  WRITE (*,'(A,/,A,F8.3,2(A,F8.2),F6.1)') &
    '* * * Error in Nitrogen Balance, please check * * *', &
    'NBCHK=',NBCHK,',CHKIN=',CHKIN,',CKCFL=',CKCFL,'at
                                     TIME=',TIME
  TERMNL = .TRUE.
END IF

```

During simulation, a nitrogen balance check is performed in the subroutine SUBNBC at each integration step. The total amount of N in the crop (ANCR) should equal the total uptake from external sources (CKCFL). The CKCFL consists of the amount of N taken up from the soil (NACRS) plus the amount of N translocated from the roots (NTRTS). The simulation is stopped when the difference between ANCR and CKCFL (called NCHCK) is more than 0.1% of the total amount of N taken up.

5.2 The soil nitrogen supply

```

SUBROUTINE NSOIL(ITASK,IUNITD,IUNITL,FILEIT,OUTPUT,DELT,DAE, &
  DVS, NACR, TNSOIL)

```

The subroutine NSOIL calculates the daily amount of N that is available for crop uptake from the soil (TNSOIL; kg N ha⁻¹ d⁻¹). The sources of N taken into account are indigenous soil N and fertilizer N. NSOIL is a simple bookkeeping routine and does not compute the dynamics of N transformation processes in the soil. The root zone of the profile is considered to be one single layer in which all mineral N is available for uptake by the crop (Aggarwal et al 1997).

```

!-----Initialization
  IF (ITASK.EQ.1) THEN
!     Reading input parameters (from experimental file)
    CALL RDINIT (IUNITD, IUNITL, FILEIT)
    CALL RDAREA ('FERTIL', FERTIL, INX, ILFERT)
    CALL RDAREA ('RECNIT', RECNIT, INX, ILREC)
    CALL RDSREA ('SOILSP', SOILSP)
    CLOSE (IUNITD)

!     Initialize state variables
    TNSOIL = 0.
    NFERTP = 0.

```

In the initialization section, model parameter values are read from the experimental data file and state variables are initialized. The model parameters

are a table of fertilizer N application rates as a function of days after emergence (FERTIL; kg N ha⁻¹ d⁻¹), a table of fertilizer N recovery fraction as a function of development stage of the crop (RECINIT; fraction), and the daily rate of indigenous soil N supply (SOILSP; kg N ha⁻¹ d⁻¹). The recovery of fertilizer N can be estimated from zero N and N fertilizer treatments in field experiments. It has been shown that the recovery of N depends on the development stage of the crop, with relatively low values at transplanting to high values at panicle initiation (De Datta 1986). For well-managed experiments at the IRRI farm, we use linearly increasing recovery fractions of 0.35 from N applied at transplanting to 0.75 from N applied at panicle initiation and thereafter (Aggarwal et al 1997, Peng and Cassman 1998). However, these values are input data read from the experimental data file, and they can be changed by the user (Section 7.2).

The indigenous soil N supply is determined by mineralization of organic matter and biological nitrogen fixation (Cassman et al 1994). It can be estimated directly from zero N field experiments by dividing the amount of N taken up by the crop by its duration. Typical values for tropical rice soils vary from 0.5 to 0.9 kg N ha⁻¹ d⁻¹ (ten Berge et al 1997). However, the average value of indigenous soil N supply calculated this way from zero N trials does not take into account variability within the season. A young crop takes up less N than an older crop. In our model, we interpret indigenous soil N supply as a potential supply that is available daily for uptake. If the crop demand is less than this potential value, the amount of N “left over” does not accumulate in the soil and is not available for uptake later in the season. It is assumed that crop N demand is first met by indigenous soil N supply, and, if this is insufficient, only then by fertilizer N. At the IRRI farm, we found a potential soil N supply of 0.5 kg N ha⁻¹ d⁻¹ in the wet season and 0.8 kg N ha⁻¹ d⁻¹ in the dry season to simulate crop uptake rates well.

5.2.1 Rate calculations

```
!-----Rate calculations
      ELSE IF (ITASK.EQ.2) THEN
!         Daily supply of N by fertilizer application
          FERT = LINT2('FERTIL',FERTIL,ILFERT,DAE)
          RECOV = LINT2('RECINIT',RECINIT,ILREC,DVS)
          XFERT = FERT*RECOV
```

In the rate calculation section, the daily amount of N available from fertilizer N is calculated from the gross fertilizer N application rate and the fertilizer N recovery fraction. The daily fertilizer N application (FERT; kg N ha⁻¹ d⁻¹) is interpolated from the fertilizer application table (FERTIL; see also Section 7.2 on how to construct this table) and the recovery fraction (RECOV; -) is interpolated from the recovery table (RECINIT) using the function LINT2. The

daily rate of net fertilizer N application (XFERT; $\text{kg N ha}^{-1} \text{d}^{-1}$) is calculated as the amount of fertilizer N applied times the recovery fraction.

5.2.2 State calculations

```
!-----State updates/integration
      ELSE IF (ITASK.EQ.3) THEN
!       Total N pool present in the soil
          NFERTP = INTGRL(NFERTP, XFERT-MAX(0.,(NACR-SOILSP)), DELT)
!       Amount of N available for uptake each day
          TNSOIL = NFERTP+SOILSP
```

In the state calculation section, the total fertilizer N pool in the soil (NFERTP; kg N ha^{-1}) is computed through integration. The daily input is the amount of net fertilizer N (XFERT) minus the amount of fertilizer N taken up by the crop, which is calculated as the daily crop N uptake rate minus the amount of indigenous soil N supply (NACR – SOILSP). The amount of N available daily for uptake by the crop the next day (TNSOIL; $\text{kg N ha}^{-1} \text{d}^{-1}$) is the sum of the fertilizer N pool present (NFERTP) and the daily indigenous soil N supply (SOILSP).

5.3 Non-nitrogen-limited growth

```
SUBROUTINE NNOSTRESS(DELTD,IUNITD,IUNITL,ITASK,FILEI1,FILEIT, &
                    CROPSTA, DVS, NFLV, NSLLV, RNSTRS)
```

The subroutine NNOSTRESS is called in ORYZA2000 instead of the subroutines NCROP and NSOIL described above when the crop model is run with no nitrogen balance (potential production). The subroutine has two functions: it reads leaf nitrogen content from the crop or the experimental data file and sets the N stress effect factors at unity.

```
!-----Initialization
      IF (ITASK.EQ.1) THEN
!       Reading input parameters (from crop file)
          CALL RDINIT(IUNITD, IUNITL, FILEI1)
          CALL RDSREA('NFLVI', NFLVI)
          CALL RDAREA('NFLVTB',NFLVTB,IMX,ILNFLV)
          CLOSE (IUNITD)

          NFLV      = NFLVI
          NSLLV     = 1.
          RNSTRS    = 1.
```

In the initialization section, the initial leaf N content (on a leaf area basis) at crop emergence (NFLVI; g N m^{-2} leaf) and a table of standard leaf N content

as a function of development stage (NFLVTB; g N m⁻² leaf) are read from the crop data file. The actual leaf N content CN_{lv} (NFLV) is initialized at NFLVI and the N stress factors that accelerate leaf death (NSLLV; -) and reduce the relative leaf growth rate (RNSTRS; -) are set at unity.

```
!-----Rate calculations
      ELSE IF (ITASK.EQ.2) THEN
!-----Calculate nitrogen content only after emergence/sowing
      IF (CROPSTA .GE. 1) THEN
!
      Read NFLV as a function of development state
      NFLV1 = LINT2('NFLVTB',NFLVTB,ILNFLV,DVS)
      NFLV   = INTGR2(0., NFLV1, DELT, FILEIT, 'NFLV')
```

In the rate calculation section, the leaf N content on an area basis (NFLV1; g N m⁻² leaf) is interpolated daily from the table of leaf N content as a function of development stage (NFLVTB). Next, a “programming trick” follows to compute the daily values of NC_{lv} (NFLV) that are passed on to the subroutine ORYZA1. The function INTGR2 from the library TTUTIL integrates a state variable with a rate variable (just as the subroutine INTGRL), but allows the use of observed values to “override” the simulated values (see also the explanation of INTGR2 in the LAI subroutine in Section 3.3). This case has the option that, instead of using the standard leaf N contents as a function of development stage as supplied under NFLVTB (in the crop data file; Section 7.3), measured values as a function of calendar day are used as supplied in the experimental data file (Section 7.2). The programming trick is that, at each time step, the value 0 is updated with either the calculated “rate variable” NFLV1 or the measured “rate variable” NFLV. The selection of which of the two options to use is governed by the setting of the parameter NFLV_FRC in the experimental data file (as explained in detail in Section 7.2): If NFLV_FRC = 0, then the standard values in the crop data file are used; if NFLV_FRC = 1, then the measured values in the experimental data file are used.

6 Soil-water balance

Two modules are used to simulate the soil-water balance of lowland rice fields. The soil-water balance model PADDY simulates the dynamics of soil water content and soil-water tension. The subroutine IRRIG determines the amount of irrigation applied to the crop each day of simulation. This irrigation amount is input for the model PADDY. The simulated soil-water tension by PADDY is used by the subroutine WSTRESS to compute the effects of drought on crop growth and development (Section 4.2). Both PADDY and IRRIG are called in ORYZA2000 when the user-defined parameter PRODENV is set to 'WATER BALANCE' in the experimental data file (Sections 2.2.1 and 7.2). The amount of rainfall and the amount of irrigation water applied determine to a large extent the level of drought stress that a rice crop will experience. If rainfall and irrigation water supply are ample, the crop will not experience water limitations and the production situation is potential. Another way to simulate potential production is to run ORYZA2000 with PRODENV = 'POTENTIAL'. Simulations with ORYZA2000 under potential production (PRODENV = 'POTENTIAL') are exactly the same as those with ORYZA2000 using the soil-water balance (PRODENV = 'WATER BALANCE') with an ample input of water (rainfall or irrigation). Before the explanation of the modules PADDY and IRRIG, a general description of lowland rice soils is given.

6.1 The lowland rice soil

In Asia, rice is mostly grown under (partially) flooded lowland conditions. Of Asia's total rice area, 74 million ha are classified as irrigated lowland and 34 million ha as rainfed lowland (IRRI 1997):

1. Irrigated lowlands are those areas that have assured irrigation for one or more crops per year, with some areas served only by supplementary irrigation in the wet season.
2. Rainfed lowland rice is grown in banded fields where water depth does not exceed 50 cm for more than 10 consecutive days and the fields are inundated for at least part of the season. Such fields have no access to an irrigation system but may have on-farm rainwater conservation facilities.

To achieve flooded conditions, lowland rice fields are always banded and most of them are puddled. Puddling usually has one or two plowings, one or two harrowings, and a final leveling under water-submerged soil conditions. Puddling reduces vertical water movement (percolation) because it destroys soil aggregates and macropore volume and increases micropore space (Moormann and van Breemen 1978). Moreover, it hampers weed growth and

provides a soft medium for roots (De Datta 1981). Crop establishment is either by transplanting seedlings that were raised in special nurseries or by direct wet seeding of pregerminated seed onto the wet soil surface. The vertical profile of a puddled soil can schematically be described by a layer of ponded water, a muddy, puddled layer with little resistance to water flow, a “plow sole” with large resistance to water flow, and the nonpuddled subsoil (Wopereis et al 1992; Fig. 6.1). Puddling is not always required to achieve flooded conditions, however, and some lowland soils are left unpuddled. If a soil has a high clay content or has an impermeable layer in its profile, the internal drainage rate may be so low that water accumulates on the surface. Under such conditions, rice may be established by direct dry seeding.

The water balance of a lowland rice field can be written as (Fig. 6.1)

$$dW = I + R + C - E - T - S - P - D \quad (6.1)$$

where (all units in mm d^{-1}) dW is the change in stored water, I is irrigation supply, R is rainfall, C is capillary rise, E is evaporation, T is transpiration, S is seepage, P is percolation, and D is surface drainage/runoff (bund overflow).

Rainfall or irrigation in excess of bund height leaves the system as surface runoff. This surface runoff can be an input for a neighboring field, but, in a sequence of fields, neighboring fields will pass on the surface runoff until it is lost in a drain, creek, or ditch. Capillary rise is the upward flow of water from the groundwater table into the root zone. Transpiration by the rice crop withdraws water from the puddled layer (which is replenished with ponded water) and from the nonpuddled subsoil if rice roots grow sufficiently deep.

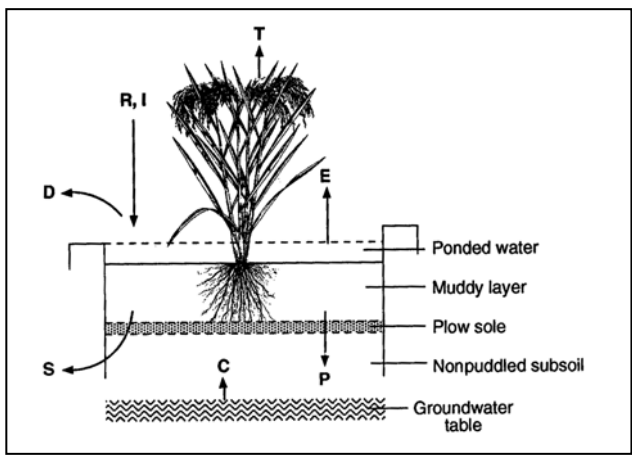

Fig. 6.1. Vertical profile and water balance of puddled soil. D = surface drainage, E = evaporation, I = irrigation, P = percolation, R = rainfall, S = seepage, T = transpiration, C = capillary rise from the groundwater table.

Evaporation occurs from the ponded water layer or from the surface of the soil. The factors that govern transpiration and evaporation rates are explained in detail in Sections 4.1 and 4.2.4.

Percolation is the vertical movement of water beyond the root zone to the water table, whereas seepage is the lateral movement of subsurface water. In practice, the two are often inseparable (Wickham and Singh 1978). Both seepage and percolation rates are governed by the hydrostatic water pressure and the resistance to water flow. For seepage, the hydrostatic water pressure is determined by piezometer head differences between fields or by the difference in depth of the water table on the field and that in surrounding drains, ditches, or creeks. Seepage loss from rice terraces in the middle of a toposequence to lower lying fields may be offset by incoming seepage from higher fields. Top-end terraces will experience net seepage loss, bottom-end terraces net seepage gain. Another possible seepage loss is leakage through and underneath the bunds: water moving laterally into the bunds and then down to the water table (Tuong et al 1994). The resistance to seepage flow is governed by the soil physical characteristics of the field and bunds, the state of maintenance, and the relative length of the bunds compared with the surface area of the field (Wickham and Singh 1978).

The hydrostatic water pressure governing percolation flow is determined by the depth of ponded water and the distance from the soil surface to the groundwater table (Ferguson 1970, Sanchez 1973, Wickham and Singh 1978). In a field survey in the Philippines, Kampen (1970) found that percolation rates were larger in fields with a deep water table (>2 m depth) than in fields with a shallow water table (0.5–2 m). The resistance to percolation flow is governed by a variety of soil factors (Wickham and Singh 1978): structure, texture, bulk density, mineralogy, organic matter content, and concentration of salts in soil solution. In general, a heavy texture, montmorillonitic clay mineralogy, high sodium content of irrigation water, and a high bulk density favor effective puddling and low percolation rates. Using a modeling approach validated by field experiments, Bouman et al (1994) and Wopereis et al (1994b) showed that, for most puddled lowland situations, percolation rates are fairly stable during a cropping season (i.e., hardly affected by practical changes in ponded water depth) and little affected by groundwater table depths. Percolation rates were only significantly affected by depths of ponded water and groundwater table for poorly puddled topsoils overlying relatively permeable subsoils, that is, in soils in which percolation rates are relatively high.

In irrigated situations, farmers ideally try to maintain a ponded water depth of about 5–10 cm throughout the growing season until terminal drainage some 1 to 2 wk before harvesting. However, conditions are not always ideal. In many large-scale irrigation systems, farmers at the tail end of canals receive irregular (or sometimes no) irrigation water and their fields often become dry between irrigations or rainfall events. Farmers who use pumps or tubewells sometimes

economize on their water use by deliberately letting their fields become dry periodically. This practice is commonly referred to as alternate wetting and drying (Bouman and Tuong 2001). In most rainfed areas, the layer of ponded water disappears when rainfall is not sufficient to compensate for all the outflow processes. In all these cases, without ponded water, there is no hydraulic pressure and the seepage and percolation rates are therefore zero. Further water loss through evaporation and transpiration causes the muddy puddled layer to dry out. The suspended soil particles settle, the soil shrinks, and a “ripening” process occurs, gradually changing the muddy topsoil into real soil. If drying out of the puddled layer continues, cracks may develop that will broaden and widen in time. Eventually, the cracks may extend through the puddled layer and plow sole into the subsoil (Fig. 6.2). Depending on the drainage capacity of the subsoil, water from rainfall or irrigation may drain immediately through the cracks into the subsoil without replenishing the (rooted) puddled layer. In heavy clay soils with a low drainage capacity, water can still get ponded on the surface, but, in the case of a relatively permeable subsoil, any ponded water will drain quickly. The capacity for shrinkage and cracking mainly depends on texture and degree of puddling; the degree of shrinkage and cracking is determined by water content and pressure head in the puddled layer. Shrinking and cracking are mostly irreversible, that is, the puddled layer will not resume its earlier properties (until renewed puddling in the next season). In heavy swelling soils, however, cracks may close by themselves after a period of continued submergence.

6.2 The soil-water balance model PADDY

PADDY is a one-dimensional soil-water balance model that can be used for both puddled and nonpuddled conditions in irrigated and rainfed environments (Wopereis et al 1996a). PADDY takes soil cracking into account. The model is divided into sections for initialization, rate calculations, state integrations, and terminal calculations. As with the other modules of ORYZA2000, the time step of integration is one day (as defined by the parameter DELT in the experimental data file, Section 7.2). In the initialization section, all model state and rate variables are given an initial value (generally 0) and model parameters are read from the data file. Except for specific conditions, this initialization section is not further detailed in the explanations below.

Soil-water tension (or suction) h is the negative value of soil water potential ψ : $h = -\psi$. Soil-water tension can be expressed in different units: mbar, cm H₂O, or kPa. In ORYZA2000, we use kPa as a standard, though some subroutines are used in PADDY that originate from other models (SAWAH; ten Berge et al 1992) and that use mbar and H₂O. The conversion is 1 kPa = 10 mbar = 10 cm H₂O. Since water tension expressed in any of these units has a large range, it is also commonly expressed in pF values, being defined as

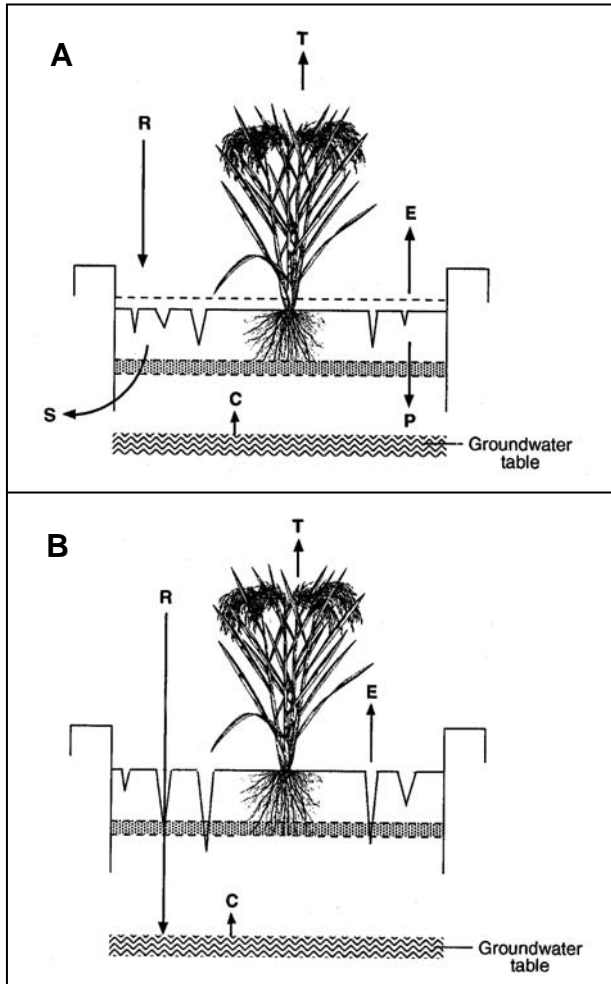

Fig. 6.2. Vertical profile and water balance of puddled soil with cracks. In (A), cracks have not yet extended through the plow sole; in (B), cracks have penetrated into the subsoil. E = evaporation, P = percolation, R = rainfall, S = seepage, C = capillary rise, and T = transpiration.

the logarithm of soil-water tension: $pF = \log |10 \times h|$, where h is expressed in kPa. For example, if the soil-water tension is 100 kPa, the corresponding pF value is 3.

6.2.1 Initial conditions

```
SUBROUTINE PADDY (ITASK, IUNITD, IUNITL, FILEI2, OUTPUT, &
DOY, DELT, TIME, CROPSTA, ESTAB, &
```

```

RAIN,   EVSC,   TRWL,   TRW,   IR,  &
NL,     ZRTMS,  TKLP,   TKLT,  &
WCAAD,  WCWP,   WCFC,   WCST,  WCL,  &
WLO,    MSKPA)

```

<Declaration of parameters>

```

IF (ITASK.EQ.1) THEN
!=====
!   Initialization                                     *
!=====
   <Setting initial conditions>
   <Reading input data from file>

```

In the initialization section (defined by ITASK = 1), model parameters are read from the soil data file and the initial conditions of the simulation are set. The reading of input parameters is done with utility routines from the library TTUTIL (Section 2.4.2).

```

!----- Read code to recognize the correctness of the supplied soil file
      CALL RDSCHA('SCODE',SCODE)
      IF (SCODE .NE. 'PADDY') THEN
          CALL FATALERR ('PADDY','Wrong soil input file for PADDY
                          water balance')
      END IF

```

In principle, since different soil-water balance models can be used in ORYZA2000, a test is executed if the supplied soil data file (Sections 7.1 and 7.4) corresponds with the soil-water balance model PADDY. This is done by reading the character parameter SCODE and checking whether this matches the word 'PADDY'.

Soil profile definition and switch settings

```

CRACKS = .FALSE.
PUDDL  = .FALSE.
GRWAT  = .FALSE.
RWCLI  = .FALSE.

```

Some logical variables are initialized and retain these values until they are overwritten later in the program:

- CRACKS = .FALSE. means that there are no cracks. For nonpuddled soils, this will remain so during the whole simulation; for puddled soils, the value of CRACKS will change into .TRUE. when cracks penetrate through the plow sole at the bottom of the puddled topsoil (in Section 6.2.3, “Shrinkage and cracking”).
- PUDDL = .FALSE. means that the soil is not puddled. This logical variable will be reset with the reading of the parameter SWITPD from the

soil data file (see below).

- GRWAT = .FALSE. means that no groundwater is taken into account; it is assumed that the groundwater table is very deep and capillary rise does not affect the water balance of the simulated soil profile. This logical variable will be reset with the reading of the parameter SWITPG from the soil data file (see below).
- RWCLI = .FALSE. means that initialization of soil water content and depth of ponded water takes place only at the start of the simulation run. This logical variable will be reset with the reading of the parameter RIWCLI from the soil data file (see below).

The following parameters that define the buildup of the soil profile are read from the soil data file:

- The switch SWITPD defines whether the topsoil is puddled (SWITPD = 1) or not (SWITPD = 0). A typical soil profile of a puddled rice soil consists of a muddy layer, a compacted layer (plow sole), and the nonpuddled subsoil. The switch SWITPD is translated into a logical variable PUDDL: PUDDL = .TRUE. if SWITPD = 1; PUDDL = .FALSE. if SWITPD = 0.
- NLPUD defines the number of puddled soil layers, including the plow sole. NLPUD is usually set at 3, that is, the first two soil layers comprise the muddy layer and the third layer represents the plow sole. If NLPUD is set at 4, then the fourth layer represents the plow sole and so on. If the soil is not puddled, NLPUD should be set at 0.
- NL defines the total number of soil layers (puddled and nonpuddled) and has a maximum value of 10 (including NLPUD). For example, NL and NLPUD can be set at 8 and 3, respectively, that is, a soil profile with three puddled soil layers (of which the third represents the plow sole) and five layers in the nonpuddled subsoil.
- The array TKLT gives the depth of each of the NL soil layers (in m).

Several switches are read from the soil data file that define the level of detail of simulation of some water-balance processes:

- The switch SWITGW determines whether groundwater is present in the soil profile. When no groundwater is present, the value of SWITGW = 0. If groundwater is present, it is either an input into the model (SWITGW = 1) or is calculated from downward fluxes (SWITGW = 2). The switch SWITGW is translated into a logical variable GRWAT: GRWAT = .TRUE. if SWITGW = 1 or SWITGW = 2; otherwise, GRWAT = .FALSE.
- The switch SWITVP defines the level of detail in the calculation of seepage and percolation rates. When SWITVP = -1, a user-defined, constant downward flux is used that combines seepage and percolation flows. When SWITVP = 0, the downward flux (seepage and percolation again combined) should be user-defined as a function of groundwater table depth. When

SWITVP = 1, seepage is not taken into account and percolation rates are dynamically calculated by the subroutine SATFLX. This subroutine, however, is only applicable for puddled soils.

- The switch SWITPF determines whether water retention characteristics (per soil layer) are given as water content values at specific water tensions (saturation, field capacity, wilting point, and when air-dried) (SWITPF = 0), or as parameter values of the van Genuchten function (SWITPF = 1).
- The switch SWITKH determines whether no hydraulic conductivity characteristics are available (SWITKH = 0) or are given as parameters of the van Genuchten function (SWITKH = 1), or are given as parameters of the power function (SWITKH = 2). The van Genuchten and power functions are explained in the subroutine SATFLX (in “Dynamic calculation of percolation rate” in Section 6.2.2).
- The switch RIWCLI determines whether reinitialization of soil water content and depth of ponded water at the time of direct seeding or transplanting in the main field should be done—yes (‘YES’) or no (‘NO’).

The reading of most other data from the soil data file is governed by the profile definition and switch settings explained above. For example, if SWITKH = 1, the van Genuchten parameters are read, whereas, if SWITKH = 2, power function parameters are read. If SWITKH = 0, no hydraulic conductivity parameters are read at all. Detailed information about what parameters should be supplied as a function of the switch settings is given in Section 7.4.

Shrinkage, cracking, and groundwater table

If a puddled soil dries out, its volume shrinks and cracks may appear. If cracks penetrate through the compacted layer (plow sole), the hydraulic resistance to vertical water flow in the topsoil changes completely. Field experiments conducted at IRRI showed that cracks penetrated through the plow sole if the water tension of the topsoil exceeds 100 kPa (IRRI 1992). In PADDY, cracks are assumed to have penetrated through a soil layer if its simulated water tension exceeds a critical pF value (PFCR; pF), which was read from the soil data file in the initialization section of the model.

```
!----- Initialize SHRINK subroutine
      IF (PUDDL) THEN
!----- Calculate water content when cracks penetrate through a
!      soil layer
          IF (SWITPF.EQ.1) THEN
              CALL SUWCMS2(NLPUD,2,WCST(NLPUD),WCCR,10**PFCR)
          ELSE
              IF (PFCR.LE.4.2.AND.PFCR.GE.0.) THEN
                  WCCR = WCWP(NLPUD)+((WCFC(NLPUD)-WCWP(NLPUD))/2.2)* &
                      (4.2-PFCR)
```

```

ELSE IF (PFCR.GT.4.2.AND.PFCR.LE.7.) THEN
    WCCR = WCAD(NLPUD)+((WCWP(NLPUD)-WCAD(NLPUD))/2.8)* &
        (7.0-PFCR)
ELSE
    CALL FATALERR ('PADDY','Please check value PFCR in
        soil data file')
END IF
END IF

I = 1
DO WHILE (I.LE.NL.AND.I.LE.NLPUD)
    CALL SHRINK(ITASK,I,WL(I),TKL(I),WCST(I),WCSTRP(I), &
        WCL(I),TOTPOR(I),VL(I))
    I = I+1
END DO
END IF

```

For the last layer of the puddled topsoil, the soil water content at which cracks penetrate through the bottom, called critical water content for cracking (WCCR; $\text{m}^3 \text{m}^{-3}$), is calculated from its PFCR value, either using the subroutine SUWCMS2 (if SWITPF = 1) or via linear interpolation of the value of PFCR between supplied values of the pF curve (if SWITPF = 0). The subroutine SUWCMS2 is derived from SUWCMS (ten Berge et al 1992, see Section 6.2.4). After the calculation, the subroutine SHRINK, which simulates shrinkage of the puddled topsoil upon drying (in Section 6.2.3, “Shrinkage and cracking”), is called for initialization.

```

!----- Check groundwater table depth
IF (GRWAT) CALL GWTAB (ITASK,SWITGW,NL,DOY,DELT,WLFL,TKL, &
    ZWPREV,IGW,ZW)

```

When the user has defined the presence of a groundwater table (SWITGW = 1 or 2), its initial depth within the soil profile is determined using the subroutine GWTAB (in Section 6.2.3, “Groundwater depth”).

6.2.2 Rate calculations

```

!=====
!   Rate calculation section
!=====
ELSE IF (ITASK.EQ.2) THEN

!----Reinitialize water content at direct seeding or transplanting
!   if requested
IF (RWCLI) THEN
    IF ((ESTAB.EQ.'TRANSPLANT' .AND. CROPSTA.EQ.3) .OR. &
        (ESTAB.EQ.'DIRECT-SEED' .AND. CROPSTA.EQ.1)) THEN

```

```

WLO = MIN(WLOI,WLOMX)
DO I=1,NL
  WCL(I) = WCST(I)
  WL(I) = WCL(I)*TKL(I)
END DO
END IF
END IF

```

After initialization, the daily flow rates (fluxes) of water through the profile are calculated. First, however, the depth of ponded water (WLO; mm) and the water content in the various soil layers (WCLI; -) are (optionally) reinitialized. The model PADDY starts simulating the water balance of the main field at the start time (STTIME) of the whole ORYZA2000 model (Section 2.2.2), using initial soil moisture conditions read from the soil data file in the initialization section of PADDY. However, when farmers sow seeds (direct wet seeding) or transplant seedlings into the main field, they often submerge or saturate the soil (again). Therefore, PADDY can be reinitialized according to the setting of the logical parameter RWCLI (which is user-defined through the parameter RIWCLI read from the soil data file in the initialization section).

The amount of ponded water is the starting point of flux calculations at the beginning of each day. The presence or absence of ponded water divides the flux calculations into two parts, with and without ponded water.

Ponded water

```

!----- 1. Ponded water on field
      IF (WLO.GE.TINY) THEN

!----- Reset number of days after ponded water
      DSPW = 1.

```

First, a counter that tracks the number of days without ponded water (DSPW) is reset to 1. This counter is used to calculate actual evaporation from the soil.

If there is ponded water, three situations can be considered: (1) ponded water can sustain both evaporation and transpiration demand, (2) ponded water can sustain evaporation but only part of transpiration demand, and (3) ponded water can sustain only part of evaporation demand.

1. Ponded water can sustain both evaporation and transpiration demand

```

!----- 1.1 Ponded water can sustain evaporation and transpiration
      IF (WLO/DELT+RAIN+IR.GE.EVSC+TRW) THEN

!----- Calculate change in ponded water depth (mm/d)
      WLOCH = RAIN+IR-EVSC-TRW

!----- Reset transpiration losses per soil layer at zero
!----- as transpiration is taken from ponded water
      I = 1

```

```

DO WHILE (I.LE.NL)
  TRWL(I) = 0
  I = I+1
END DO

!----- For water balance check
EVSU = EVSC
EVSWS = 0.

```

The ponded water level in the field (WL0; mm), possibly augmented with rainfall (RAIN) and/or irrigation (IR) (mm d^{-1}), is sufficient to sustain both potential soil evaporation (EVSC; mm d^{-1}) and crop transpiration (TRW; mm d^{-1}) demand (calculated in the subroutines ET and WSTRESS and passed on to PADDY through the subroutine MODELS; Section 2.2.2). A change in ponded water level WL0CH (mm d^{-1}) is calculated by subtracting loss rates (EVSC+TRW) from gain rates (RAIN+IR). Note that WL0 is a state variable (mm); WL0/DELT and WL0CH are rate variables (mm d^{-1}). Since the transpiration rate TRW can be extracted completely from the ponded water layer, no water is withdrawn from the soil and transpiration withdrawals per soil layer (TRWL(I); mm d^{-1}) are set at zero.

```

!----- Set fixed percolation rate PERCOL
IF (SWITVP.EQ.-1) THEN
  PERCOL = FIXPERC
ELSE IF (SWITVP.EQ.0) THEN
  PERCOL = LINT2('PERTB',PERTB,IPERTB,ZW)
END IF

```

Next, the percolation rate (downward flux) PERCOL (mm d^{-1}) is defined. If SWITVP is -1 , a fixed value (FIXPERC) is used that was read from the soil data input file in the initialization section of PADDY. If SWITVP is 0, a value is linearly interpolated from a table relating percolation rates to groundwater table depths (PERTB) that was read from the soil data input file. If SWITVP is 1, then the percolation rate is not user-defined but calculated with the routine SATFLX (see “Dynamic calculation of percolation rate” below).

```

!-----For nonpuddled soils and puddled soils with no cracks
IF (.NOT.CRACKS) THEN
!-----Calculate percolation rate (mm/d)
  IF (SWITVP.EQ.0 .OR. SWITVP.EQ.-1) THEN
    IF (WL0/DELT+WL0CH.GE.PERCOL) THEN
      PERC = PERCOL
    ELSE
      PERC = WL0/DELT+WL0CH
    END IF

```

For nonpuddled soils and puddled soils without cracks that penetrate the plow sole, the downward water flow PERC (mm d^{-1}) is defined by the

percolation rate. When a user-defined percolation rate is supplied, PERC equals PERCOL. However, PERC can never be larger than the amount of ponded water plus the daily rate of change determined by the sum of rainfall, irrigation, evaporation, and transpiration (WLO/DELT+WLOCH).

```

ELSE
  CALL SATFLX(TKL,NLPUD,WLO,PERC)
  IF (WLO/DELT+WLOCH.LE.PERC) PERC = WLO/DELT+WLOCH
END IF

```

If the percolation rate is not user-defined but is to be simulated by PADDY, the percolation rate PERC is calculated with the routine SATFLX (see ““Dynamic calculation of percolation rate” below). Again, the calculated percolation rate PERC is limited to the amount of ponded water plus the daily rate of change determined by the sum of rainfall, irrigation, evaporation, and transpiration.

```

*----- Recalculate change in ponded water depth (mm/d)
      WLOCH = WLOCH - PERC
*----- Calculate runoff (mm/d) if ponded water depth
*----- exceeds bund height
      IF (WLO+WLOCH*DELT.GE.WLOMX) THEN
          RUNOF = (WLO+WLOCH*DELT-WLOMX)/DELT
          WLOCH = WLOCH-RUNOF
      END IF

```

After assessment of the actual percolation rate (PERC), the rate of change in ponded water depth (WLOCH; mm d⁻¹) is recalculated. If the depth of ponded water plus the rate of change exceeds the bund height (WLOMX; mm), water is lost from the soil profile as runoff (RUNOF; mm d⁻¹) and the change in ponded water depth is again reset.

```

      I = 1
      DO WHILE (I.LE.NL+1)
          WLFL(I) = PERC
          I = I + 1
      END DO

```

In PADDY, the flux of water between each soil layer is tracked separately in the variable WLFL(I) (mm d⁻¹). In total, there are NL + 1 flow rates, where NL is the number of soil layers, WLFL(1) is the flow rate between the ponded water layer and the soil surface, WLFL(2) is the flow rate between soil layer (1) and soil layer (2), etc. Under conditions of ponded water, all flow rates are assumed to be equal to the percolation rate.

```

!-----For puddled soils with cracks
      ELSE
!-----Calculate flow through boundaries of soil layers

```



```

WLFL(1) = RAIN+IR-EVSC-TRW
I = 1
DO WHILE (I.LE.NL)
    CALL DOWNFL(I,KSAT(I),WLFL(I),TRWL(I),EVSWS,WL(I), &
        WLFC(I),DELT,WLFL(I+1))
    I = I+1
END DO

I = NL
DO WHILE (I.GE.1)
    CALL BACKFL(I,WL(I),WLFL(I),WLFL(I+1),EVSWS, &
        TRWL(I),WLST(I),DELT,FLNEW,REST)
    WLFL(I) = FLNEW
    I = I-1
END DO

```

For puddled soils with cracks that penetrate the plow sole, the ponded water on the soil surface will flow downward at a rate that depends on the hydraulic characteristics of the subsoil. In this case, the concept of percolation rate cannot be used. Instead, two subroutines determine the fate of water flow: DOWNFL and BACKFL (see below). First, the downward fluxes WLFL(I) are initialized as being equal to the sums of rainfall and irrigation, minus evaporation and transpiration.

```

WLOCH = MAX(0.,(REST-WLST(1))/DELT)
IF (WLO+WLOCH*DELT.GE.WLOMX) THEN
    RUNOF = (WLO+WLOCH*DELT-WLOMX)/DELT
    WLOCH = WLOCH-RUNOF
END IF
END IF

```

After initialization of the downward fluxes WLFL(I), the rate of change in ponded water depth WLOCH is calculated. Water in excess of bund height is lost from the soil profile through runoff, and the rate of change in ponded water depth is recalculated.

The subroutine DOWNFL

Using the subroutine DOWNFL, incoming water (rainfall plus irrigation; WLFL(I), FLIN) is redistributed by calculating for all layers gain and loss terms, starting with the top layer. All water in excess of field capacity is drained from the layer, with a maximum rate equal to the saturated hydraulic conductivity of the layer, KSAT(I). If the rate is low, the water content of the layer may reach saturation, that is, a perched water table may develop. Note that KSAT(I) is multiplied by 10 to convert from cm d^{-1} to mm d^{-1} .

```

SUBROUTINE DOWNFL(I,KSAT,FLIN,TRWL,EVSWS,WL,WLFC,DELT,FLOUT)
IMPLICIT REAL (A-H,J-Z)

```

```

IF (I.EQ.1) THEN
    FLOUT = MIN(10*KSAT,MAX(0.,FLIN-EVSWs-TRWL+(WL-WLFC)/DELT))
ELSE
    FLOUT = MIN(10*KSAT,MAX(0.,FLIN-TRWL+(WL-WLFC)/DELT))
END IF
RETURN
END

```

The subroutine BACKFL

If the soil profile is not freely draining, one or more soil layers in the profile restrict water flow. Using the subroutine BACKFL and starting with the last layer, in- and outflow fluxes are then compared. If the outflow flux for a given layer is too low (i.e., the resulting water content of the layer would be higher than its saturated water content), the excess water is redistributed upward. This means that, although the cracked topsoil is freely draining, water may still start ponding on the soil surface because of a layer with a low saturated hydraulic conductivity deeper in the soil profile. Ponding of water will occur if the rest term (HLP in subroutine BACKFL) for $I = 1$ is larger than the water-holding capacity of the first soil layer (WLST(1)).

```

SUBROUTINE BACKFL(I,WL,FLIN,FLOUT,EVSWs,TRWL,WLST,DELT,
&
    FLNEW,HLP)
IMPLICIT REAL (A-H,J-Z)
HLP = 0.
IF (I.EQ.1) THEN
    HLP = WL+(FLIN-FLOUT-EVSWs-TRWL)*DELT
ELSE
    HLP = WL+(FLIN-FLOUT-TRWL)*DELT
END IF
IF (HLP.GT.WLST) THEN
    FLNEW = FLIN - (HLP-WLST)/DELT
ELSE
    FLNEW = FLIN
END IF
RETURN
END

```

2. *Ponded water depth can sustain evaporation but only part of transpiration*

```

!----- 1.2 Ponded water depth can sustain evaporation but
!----- only part of transpiration

```

```

ELSE IF ((WL0/DELT+RAIN+IR.GE.EVSC).AND. &
    (WL0/DELT+RAIN+IR.LT.EVSC+TRW)) THEN

```

```

!----- Calculate change in ponded water depth (mm/d)
    WL0CH = -WL0/DELT

```

If the amount of ponded water plus daily rain and irrigation additions ($WL0/DELTA+RAIN+IR$) is sufficient to meet the evaporation demand, but not sufficient to meet both evaporation and transpiration demands ($EVSC+TRW$), all ponded water will be consumed ($WL0CH = -WL0/DELTA$).

```
*----- Percolation is zero because no ponded water is left
      PERC = 0.
      I=1
      DO WHILE (I.LE.NL+1)
          WLFL(I) = PERC
          I = I + 1
      END DO
```

Percolation rate PERC is assumed to be zero in this case, as no ponded water is left. This also holds for the flow from the rest of the soil layers ($WLFL(I)$).

```
*----- Correct transpiration losses per soil layer as
*----- transpiration losses are partly covered by ponded water
      I = 1
      DO WHILE (I.LE.NL)
          TRWL(I) = ((TRW+EVSC-RAIN-IR-WL0/DELTA)/TRW)
          $                                     *TRWL(I)*DELTA
          I = I + 1
      END DO
*----- For water balance check
      EVSW = EVSC
      EVSWS = 0.
```

The part of transpiration that cannot be provided for by the ponded water plus any daily additions (rain, irrigation) is withdrawn from the soil. The transpiration loss per soil layer, $TRWL(I)$, an input to PADDY, is decreased by the ratio $(TRW+EVSC-RAIN-IR-WL0/DELTA) / TRW$.

3. *Ponded water can sustain only part of evaporation demand*

```
*----- 1.3 Ponded water can sustain only part of evaporation
      ELSE IF (WL0/DELTA+RAIN+IR.LT.EVSC) THEN
*----- Calculate change in ponded water depth (mm/d)
      WL0CH = -WL0/DELTA
      PERC = 0.
      WLFL(1) = RAIN + IR
      I = 2
      DO WHILE (I.LE.NL+1)
          WLFL(I) = PERC
          I = I + 1
      END DO
```

As all ponded water is used to cover (part of) the evaporation demand, the percolation rate PERC is assumed to be zero. The flux at the soil surface WLFL(1) is equal to incoming rainfall and irrigation, RAIN+IR. Transpiration losses are covered completely by water taken from the soil.

```
*----- Calculate contribution of first soil layer to evaporation
      EVSW = MIN(EVSC+WLOCH,WL(1)/DELTA-
$                               WLAD(1)/DELTA+RAIN+IR)
      EVSWS = EVSW
*----- for water balance check
      EVSW = WLO/DELTA+EVSWS
      END IF
```

The soil evaporation demand not met from the ponded water (EVSC+WLOCH) is taken from incoming rainfall and irrigation (RAIN+IR) and from water available in the topsoil layer. This is later computed as the actual amount of water in the topsoil layer (WL(1); mm) minus the amount of water at air dryness in the topsoil layer (WLAD(1); mm). Because EVSC, WLOCH, RAIN, and IR are all rate variables (mm d⁻¹), these amounts of water are divided by the time step DELT. The sum of the amount of water available in the topsoil layer plus rainfall and irrigation sets a limit to the value of EVSW.

Dynamic calculation of percolation rate

```
SUBROUTINE SATFLX(TKL,NLPUD,WLO,PERC)
```

The subroutine SATFLX calculates vertical percolation rates using an iterative Newton-Raphson procedure (Wolfram 1991) from hydraulic conductivity characteristics of the plow sole and the nonpuddled subsoil. Such hydraulic conductivity characteristics need to be specified in a parameterized format, using either van Genuchten parameters (van Genuchten 1980, van Genuchten et al 1991) or a simple power function. Van Genuchten's equations are

$$S = (\theta - \theta_r) / (\theta_s - \theta_r) = [1 + |\alpha_\psi|^n]^{-m} \quad \text{and} \quad (6.2)$$

$$k(S) = k_s S^l [1 - (1 - S^{1/m})^m]^2 \quad (6.3)$$

where S is the degree of saturation; $k(S)$ is the hydraulic conductivity at S (cm d⁻¹); θ_r (-) and θ_s (-) are the residual and saturated values of the volumetric water content θ (-); k_s is the saturated hydraulic conductivity (cm d⁻¹); α_ψ (cm⁻¹), n (-), m (-), and l (-) are parameters that determine the shape of the functions; and $m = 1 - 1/n$.

A power function is written as

$$k(\psi) = k_s |\psi|^n \quad (6.4)$$

where $k(\psi)$ is the hydraulic conductivity at potential ψ (cm d⁻¹), k_s is the

saturated hydraulic conductivity (cm d^{-1}), ψ is the water potential (kPa), and n is a soil-specific dimensionless constant. The switch SWITKH, defined in the soil data input file, is used to define the parameterization method used, that is, SWITKH = 1 for van Genuchten functions and SWITKH = 2 for power functions. Section 7.4 explains how to obtain the van Genuchten and power function parameters.

In SATFLX, vertical fluxes through the plow sole and the nonpuddled subsoil are calculated and compared until the difference between both fluxes becomes negligible. The procedure is illustrated in Figure 6.3. SATFLX starts by taking a random value for the water potential ψ in the nonpuddled subsoil (1). The difference between the flux through the puddled topsoil (f_t) and the nonpuddled subsoil (f_s) at that potential is then calculated (2). The flux through the puddled topsoil equals (Wopereis et al 1992)

$$f_t = -k_s (\psi_t - \psi_b + z_1)/z_1 \quad (6.5)$$

where k_s is the saturated hydraulic conductivity of the plow sole (cm d^{-1}) with thickness z_1 , ψ_t is the water potential ($\text{cm H}_2\text{O}$) at the top of the plow sole, and ψ_b is the water potential at the bottom of the plow sole. Assuming gravity flow in the subsoil, the flux in the subsoil can be written as (Wopereis et al 1992)

$$f_s = -k(\psi_b) \quad (6.6)$$

where k is the hydraulic conductivity. If the difference between f_t and f_s is too large, the intersection of the tangent line with the x -axis is calculated, which yields a new value for ψ_b (3). A new difference between fluxes f_t and f_s is

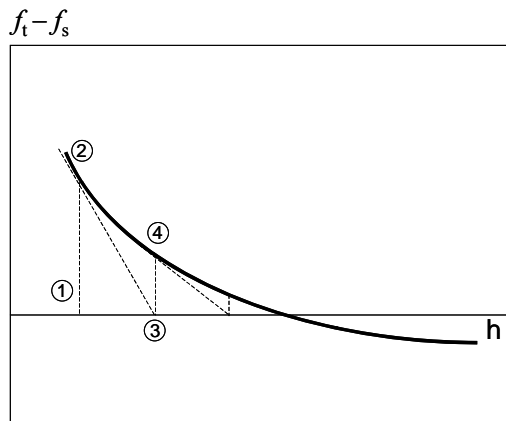

Fig. 6.3. Iterative procedure used in the subroutine SATFLX to calculate percolation rates for a puddled soil by minimizing the difference between the fluxes through the plow sole (f_t) and the nonpuddled subsoil (f_s).

Table 6.1. Steady-state percolation rates calculated using SATFLX in PADDY and using SAWAH, at a constant ponded water depth of 15 cm. k_s is the saturated hydraulic conductivity of the plow sole (cm d^{-1}). Hydraulic conductivity characteristics of the subsoil were taken from Wopereis et al (1993b).

Saturated hydraulic conductivity	SAWAH (groundwater table at 1 m)	SAWAH (groundwater table at 5 m)	PADDY (no groundwater table)
$k_s = 0.03$	1.4	1.4	1.7
$k_s = 0.10$	4.5	4.5	5.2
$k_s = 0.30$	33.4	149.5	14.9

calculated (4), etc. The calculations continue until the difference between f_i and f_s becomes close to zero.

The subroutine SATFLX was validated by comparing steady-state percolation rates calculated with the one-dimensional dynamic soil-water balance model SAWAH (ten Berge et al 1992) and PADDY. SAWAH simulates fluxes between layers using small variable time steps. Table 6.1 shows that SAWAH and PADDY predictions are close if the plow sole conductivity is small, regardless of groundwater table depth. SATFLX should not be used if the conductivity of the plow sole is larger than 0.1 cm d^{-1} (Bouman et al 1994). Under such circumstances, the percolation rates predicted by PADDY may be too small and a constant percolation and seepage rate should be defined instead (SWITVP = -1 or 0).

No ponded water

```

ELSE
!----- 2. No ponded water on surface
!----- Calculate evaporation rate from soil surface (mm/d)
EVSH = MIN(EVSC, MAX(0., (WL(1)-WLAD(1))/DELTA+RAIN+IR))
EVSD = MIN(EVSC, 0.6*EVSC*(SQRT(DSPW)-SQRT(DSPW-1.))+RAIN+IR)
EVSW = INSW(DSPW-1.1, EVSH, EVSD)
EVSW = MIN(EVSW, MAX(0., RAIN+IR+(WL(1)-WLAD(1))/DELTA))
EVSWS = EVSW
DSPW = DSPW+1.
WLFL(1) = RAIN+IR

```

If there is no ponded water, the evaporative demand is met by taking water from the first soil layer. Actual soil evaporation is calculated by assuming that the cumulative evaporation is proportional to the square root of time (Penning de Vries et al 1989). The rate of evaporation on the first day without ponded water is assumed to be 60% of the potential soil evaporation rate. A counter DSPW keeps track of the number of days that have passed without ponded water.

```

I = 1
DO WHILE ( I.LE.NL)
    CALL DOWNFL(I,KSAT(I),WLFL(I),TRWL(I),EVSWS,WL(I), &
                WLFC(I),DELT,WLFL(I+1))
    I = I+1
END DO

I = NL
DO WHILE ( I.GE.1)
    CALL BACKFL(I,WL(I),WLFL(I),WLFL(I+1),EVSWS,TRWL(I), &
                WLST(I),DELT,FLNEW,REST)
    WLFL(I) = FLNEW
    I = I-1
END DO

```

The subroutines DOWNFL and BACKFL are again used to redistribute water in the soil profile.

```

IF (WL0+WLOCH*DELT.GE.WLOMX) THEN
    RUNOF = (WL0+WLOCH*DELT-WLOMX)/DELT
    WLOCH = WLOCH-RUNOF
END IF
END IF

```

If the depth of ponded water (WL0) plus the rate of change (WLOCH) exceeds the bund height (WLOMX; mm), water is lost from the soil profile as runoff (RUNOF; mm d⁻¹) and the change in ponded water depth is again reset.

Drainage to groundwater

```

IF (GRWAT) THEN
!----- Drain layers in groundwater
    I = IGW
    DO WHILE ( I.LE.NL)
        IF (WL(I).GE.WLFC(I)) THEN
            DRAIN = (WL(I)-WLFC(I))/DELT
            WLFL(I+1) = DRAIN+MAX(0.,WLFL(I)-TRWL(I))
        ELSE
            WLFL(I+1) = MAX(0.,WLFL(I)-TRWL(I)+(WL(I)-WLFC(I)) &
                            /DELT)
        END IF
        I = I+1
    END DO

```

It is assumed that soil layers in the subsoil that are saturated with water because of the presence of a groundwater table drain to their field-capacity water content, WLFC(I), within the time step DELT (one day). The flux from each soil layer, WLFL(I+1), is calculated taking into account the amount of water drained until field capacity is reached, DRAIN, losses because of transpiration

(TRWL(I)), and the flux into this soil layer, WLFL(I). The shallowest soil layer containing groundwater is known via calls to the subroutine GWTAB (which stores this layer number in the variable IGW) in the integration of states section (in Section 6.2.3, "Groundwater depth").

```

I = NL
GWTOT = 0.
WLOFILL = 0.
DO WHILE (I.GE.1)
  GWFILL(I) = 0.
!----- Check whether groundwater in soil layer
!----- If groundwater table is negative, it is assumed that
!----- this represents water on the soil surface
  IF ((ZW.LT.0).AND.(-10*ZW.GT.WL0+WLOCH)) THEN
    WLOFILL = -10*ZW-(WL0+WLOCH)
  END IF
  GWCHK = MAX(0.,ZW-ZL(I)-0.5*TKL(I)/10.)
  IF (GWCHK.EQ.0.) THEN
    IF (I.EQ.1) THEN
      GWFILL(I) = MAX(0.,(WLST(I)-WL(I))/DELT+TRWL(I)+ &
        WLFL(I+1)+EVSWS-WLFL(I))
    ELSE
      GWFILL(I) = MAX(0.,(WLST(I)-WL(I))/DELT+TRWL(I)+ &
        WLFL(I+1)-WLFL(I))
    END IF
    GWTOT = GWTOT+GWFILL(I)
  END IF

```

After resetting the soil water content to field capacity, the current groundwater table depth ZW obtained from a call to the subroutine GWTAB in the state integration section (Section 6.2.3, "Groundwater depth") is used to fill soil layers up to saturation.

Capillary rise

```

!----- Capillary rise
FLOW = 0.
IF (WL(I).GT.WLAD(I).AND.WL(I).LT.WLFC(I).AND.ZW.GT.ZL(I) &
+TKL(I)/10.) THEN
  IF ((SWITKH.NE.0).AND.(SWITPF.EQ.0)) THEN
    IF (WCL(I).GE.WCFC(I)) THEN
      FACT = MAX(0., &
        MIN(1.,(WCST(I)-WCL(I))/(WCST(I)-WCFC(I))))
      MS(I) = 10.**((FACT*2.0))
      IF (WCL(I).GE.WCST(I)) MS(I) = 0.
    ELSE IF (WCL(I).GE.WCWP(I).AND.WCL(I).LT.WCFC(I)) THEN
      FACT = MAX(0., &
        MIN(1.,(WCL(I)-WCWP(I))/(WCFC(I)-WCWP(I))))

```



```

      MS(I) = 10.** (4.2-FACT*2.2)
    ELSE IF (WCL(I).LT.WCWP(I)) THEN
      FACT = MAX(0., &
        MIN(1., (WCL(I)-WCAD(I))/(WCWP(I)-WCAD(I))))
      MS(I) = 10.** (7.0-FACT*2.8)
    END IF
  END IF
  IF ((SWITKH.NE.0).AND.(SWITPF.EQ.1)) &
    CALL SUWCMS2(I,1,WCST(I),WCL(I),MS(I))
  IF (MS(I).GT.100.) &

```

Capillary rise from the groundwater table to a soil layer is assumed to occur only if the soil-water tension of this layer (MS(I); mbar or cm H₂O) is higher than field capacity (defined as 100 mbar (pF 2)). So, first the soil-water tension is calculated from the soil water content (WCL(I)). If no van Genuchten parameters are available, the soil-water tension (FACT; pF) is calculated from linear interpolation between the user-supplied characteristic points of the pF curve (water content at saturation, WCST, at field capacity, WCFC, at wilting point, WCWP, and at air dryness, WCAD). The soil-water tension in pF value (FACT) is then transformed into the soil-water tension in mbar (MS). If van Genuchten parameters are available, the subroutine SUWCMS2 is used to calculate MS(I) (Section 6.2.4).

```

      CALL SUBSL2(LOG10(MS(I)),ZW-ZL(I)+0.5*TKL(I)/10.,I, &
        WCST(I),FLOW)
!
  IF (FLOW.LT.0) FLOW = 0.
  IF (I.EQ.1) THEN
    CAPRI(I) = MIN(FLOW, (WLST(I)-WL(I))/DELTA+EVSW+TRWL &
      (I)+WLFL(I+1)-WLFL(I))
  ELSE
    CAPRI(I) = MIN(FLOW, (WLST(I)-WL(I))/DELTA+TRWL(I)+ &
      WLFL(I+1)-WLFL(I))
  END IF
  END IF
  CAPTOT = CAPTOT+CAPRI(I)
  I = I-1
END DO
END IF

```

Capillary rise to soil layers above the groundwater table is calculated using a “window-structure,” that is, water flow to each soil layer is calculated separately (CAPRI(I); mm d⁻¹). The total capillary rise FLOW is calculated using the WOFOST subroutine SUBSOL (van Diepen et al 1988), which is changed slightly to allow for the use of van Genuchten parameters. To avoid confusion, the subroutine is renamed SUBSL2. Input to SUBSL2 is the soil-

water tension MS. Capillary rise can only decrease with increasing distance from the groundwater table. If the calculated capillary rise CAPRI(I) of a layer higher in the profile is larger than the layer below, the capillary rise is reset at the value of the layer closer to the groundwater table. Total capillary rise from the groundwater table (CAPTOT) is the sum of the capillary rise to each individual soil layer (CAPRI(I)).

Soil water content

```

I = 1
DO WHILE (I.LE.NL)
  IF (I.EQ.1) THEN
    WLCH(I) = WLFL(I)-WLFL(I+1)-TRWL(I)-EVSWS+CAPRI(I) &
              +GWFILL(I)
  ELSE
    WLCH(I) = WLFL(I)-WLFL(I+1)-TRWL(I)+CAPRI(I)+GWFILL(I)
  END IF
  WCUMCH = WCUMCH+WLCH(I)
  I = I+1
END DO

```

At the end of the dynamic section of the module, changes in water content of the soil layers (WLCH(I)) are calculated by summing the fluxes in (WLFL(I)) and out (WLFL(I+1)) of the layers, the extraction of water by transpiration (TRWL(I)), the extraction by evaporation (EVSWS) in the case of the topsoil layer only, the capillary rise (CAPRI(I)), and the drainage to the groundwater (GWFILL(I)).

6.2.3 Integration of states

```

!=====
!   State update section                               *
!=====
      ELSE IF (ITASK.EQ.3) THEN

```

After the rate calculation section, the state variables are integrated (ITASK.EQ.3). First, the depth of groundwater is calculated.

Groundwater depth

```

      IF (GRWAT) THEN
!----- New groundwater table depth
          ZWPREV = ZW
          CALL GWTAB(ITASK,SWITGW,NL,DOY,DELT,WLFL,TKL,ZWPREV,IGW,ZW)
      END IF

```

The groundwater table depth (ZWPREV, ZW; cm) is calculated with the subroutine GWTAB. Inputs into this subroutine are the groundwater table

switch SWITGW (see “Soil profile definition and switch settings” in Section 6.2.1), NL (number of soil layers), DOY (day of year), DELT (time step of integration, 1 day), WLFL (array containing fluxes at soil layer boundaries), TKL (array of thickness of soil layers), and ZWPREV (previous groundwater table depth). Outputs are IGW (shallowest soil layer in groundwater) and ZW (new groundwater table depth; m).

```

SUBROUTINE GWTAB( ITASK, SWITGW, NL, DOY, DELT, WLFL, TKL, ZWPREV, IGW, ZW)
  <...>
  IF (SWITGW.EQ.1) THEN
    ZW = LINT(ZWTB, IZWTB, DOY)
  ELSE
    <...>
    ZW = ZW + ZWA - ZWB*10*WLFL(IGW)*DELT
    IF (ZW.LT.MINGW) ZW = MINGW
    IF (ZW.GT.MAXGW) ZW = MAXGW
  END IF
  <...>

```

If SWITGW = 1, groundwater table depth is read from the table ZWTB. If SWITGW = 2, it is assumed that the groundwater table depth is receding with a constant speed, ZWA. The flux at the bottom of the soil layer IGW, WLFL(IGW), multiplied by a sensitivity factor ZWB, brings the water table closer to the soil surface. The values of ZWA and ZWB are read from the soil data file in the initialization section of PADDY.

Water content

During the integration phase of the module, changes in state variables are integrated using the time step DELT.

```

*---- Integration of state variables
      WL0 = INTGRL(WL0, WL0CH, DELT)

```

First, the depth of ponded water (WL0; mm) is calculated from the daily rate of change (WL0CH; mm d⁻¹) using the INTGRL function of TTUTIL (Section 2.4.1).

```

! Force observed water content values per layer, if available and
! selected; otherwise, integrate simulated values
IF (NL.GE.1) WCL(1) = INTGR2(WCL(1), WLCH(1)/TKL(1), DELT, FILEI2, 'WCL1')
IF (NL.GE.2) WCL(2) = INTGR2(WCL(2), WLCH(2)/TKL(2), DELT, FILEI2, 'WCL2')
IF (NL.GE.3) WCL(3) = INTGR2(WCL(3), WLCH(3)/TKL(3), DELT, FILEI2, 'WCL3')
IF (NL.GE.4) WCL(4) = INTGR2(WCL(4), WLCH(4)/TKL(4), DELT, FILEI2, 'WCL4')
IF (NL.GE.5) WCL(5) = INTGR2(WCL(5), WLCH(5)/TKL(5), DELT, FILEI2, 'WCL5')
IF (NL.GE.6) WCL(6) = INTGR2(WCL(6), WLCH(6)/TKL(6), DELT, FILEI2, 'WCL6')
IF (NL.GE.7) WCL(7) = INTGR2(WCL(7), WLCH(7)/TKL(7), DELT, FILEI2, 'WCL7')
IF (NL.GE.8) WCL(8) = INTGR2(WCL(8), WLCH(8)/TKL(8), DELT, FILEI2, 'WCL8')

```

```

IF (NL.GE.9) WCL(9) = INTGR2(WCL(9),WLCH(9)/TKL(9),DELT,FILEI2,'WCL9')
IF (NL.GE.10) WCL(10)=INTGR2(WCL(10),WLCH(10)/TKL(10),DELT,FILEI2,'WCL10')

```

The water content of each soil layer (WCL(I); -) is integrated using the function INTGR2 from the library TTUTIL. This function integrates a state variable (here, WCL(I)) with a rate variable (here, WLCH(I)), but allows the use of observed values to “overrule” the simulated values. Observed values of WCL(I) can be user-supplied for different layers in the soil data file, in the table WCLX_OBS, where X denotes the soil layer under consideration (1,2,... until the last soil layer) (Section 7.4). The parameter WCLX_FRC (forcing switch), also set in the soil data file, steers the choice of integration. If WCL1_FRC = 0, then INTGR2 executes a normal integration of WCL(1) using the rate variable WLCH(1). If WCL1_FRC = 1, then interpolated values between consecutive observed WCL1 values are returned by INTGR2 for the specific day of simulation. If no observed values are given for a certain soil layer, then the water content for that specific layer is automatically obtained by integration of the simulated rate of change. The water content is calculated for each soil layer separately up to the maximum number of 10.

```

! Limit water content by saturation and air-dryness values per layer
! and calculate amount of water in each layer
DO I=1,NL
    WCL(I) = MIN(WCST(I),MAX(WCL(I),WCAD(I)))
    WL(I) = WCL(I)*TKL(I)
END DO

```

After integration, the program checks whether the obtained water content of each layer is not outside its physical maximum (saturated water content, WCST) or minimum (water content at air dryness, WCAD). This step ensures that measurement errors in observed water content do not exceed the physical limits as set in the soil data file. The amount of water in each layer (WL(I); mm) is obtained by multiplying the water content by its thickness (TKL(I)).

```

! Interpolate for soil layers in between observed layers
I = 1
DO WHILE (I.LT.3*NL)
    I2 = WCLINT(I)
    J = WCLINT(I+1)
    K = WCLINT(I+2)
    IF (WCLINT(I).NE.WCLINT(J) &
        .AND. WCLINT(I).NE.WCLINT(K)) THEN
        WCL(I2) = (WCL(J)+WCL(K))/2.
        WCL(I2) = MIN(WCST(I2),MAX(WCL(I2),WCAD(I2)))
        WL(I2) = WCL(I2)*TKL(I2)
    END IF
    I = I+3
END DO

```

The integration of water contents allowed the use of measured values to overrule simulated values for each soil layer. Quite often, measurements of soil moisture content are not made for all defined soil layers but at certain depths only. Simulated soil water content for which no observed values are available can again be overruled by interpolation between (observed) water contents of over- and underlying soil layers. This option is governed by the user-defined variable WCLINT(I), which defines for each soil layer whether interpolation needs to take place, and, if so, between which layers. For each layer, WCLINT requires three numbers: the first one identifies the layer number under consideration and the second and third the over- and underlying layers to be used in the interpolation, respectively (Section 7.4). If all three numbers are the same (i.e., all referring to the same layer), no interpolation is performed. After interpolation, the obtained soil water contents are again checked against physical limits and the amount of water in each layer (WL(I)) is calculated.

Shrinkage and cracking

```

IF (PUDDL) THEN
  I = 1
  DO WHILE (I.LE.NL.AND.I.LE.NLPUD)
    CALL SHRINK(ITASK,I,WL(I),TKL(I),WCST(I),WCSTRP(I),WCL(I), &
              TOTPOR(I),VL(I))

```

For puddled soils, the soil water content WCL(I) is recalculated using the subroutine SHRINK to account for shrinkage effects when the soil dries out. It is assumed that soil shrinkage is irreversible, that is, the total porosity of a dried, previously puddled soil layer cannot increase in case of rewetting, unless intensive repuddling is carried out. A shrinkage factor, defined as the ratio of total porosity of puddled and nonpuddled soil, is used to calculate volume change. It is assumed that the puddled soil remains saturated during shrinkage, that is, water loss equals volume change, until the total porosity is equal to that of nonpuddled soil. More than one shrinking soil layer can be defined. Inputs to the subroutine SHRINK are volume of water in soil layer I, WL(I) (mm), thickness, TKL(I) (mm), and saturated volumetric water content after puddling, WCST(I), and after ripening, WCSTRP(I) (both in $\text{m}^3 \text{m}^{-3}$). Outputs are volumetric water content, WCL(I) in $\text{m}^3 \text{m}^{-3}$, total porosity, TOTPOR(I) ($\text{m}^3 \text{m}^{-3}$), and new thickness of the soil layer after shrinkage, VL(I) (mm).

SHRINK is not used to simulate the depth of soil cracks. This would be possible by dividing the puddled topsoil into a large number of small layers and by calculating the water content and volume change of each small layer. If water loss in the soil profile is determined by evaporation and incoming rainfall only (no crop), this is feasible, as was shown by Bronswijk (1989). If a rice crop is grown, the situation is a lot more complex as the uptake of water by the crop as a function of depth is unknown. In PADDY, a more empirical approach is therefore used. Bronswijk (1988) presented the simulation model FLOCR, in

which shrinkage characteristics of soils are included as hydraulic parameters that can be specified for each soil layer. In this version of PADDY, a simplified approach to shrinkage is followed as it is expected that data on shrinkage characteristics of puddled soil will rarely be available.

```

IF (WCL(I).LT.WCCR) THEN
  KSAT(I) = 1000.
  WRITE(*,*) 'Cracks reached layer ',I,' at time ',
                                                    TIME
END IF
IF (WCL(NLPUD).LT.WCCR) CRACKS = .TRUE.

```

Cracks break through a soil layer when the actual water content of that layer (WCL(I)) is lower than the critical water content for cracking (WCCR). Its saturated hydraulic conductivity value KSAT is then set at an arbitrarily chosen high value (1,000 cm d⁻¹) and an informative message is sent to the screen. If the actual water content of the plow sole (WCL(NLPUD)) is lower than the critical water content for cracking (WCCR), cracks have reached the bottom of the puddled layer and the logical variable CRACKS is set at .TRUE.

```

      WLST(I) = VL(I)*TOTPOR(I)
      WLFC(I) = WLST(I)
      I = I + 1
END DO
END IF

```

For each soil layer, the new saturated storage capacity (WLST(I); mm) is calculated by multiplying its new thickness (VL(I); mm) by its new total porosity (TOTPOR(I); -). The storage capacity at field capacity (WLFC(I); mm) is assumed to be equal to the saturated storage capacity. This last assumption is not supported by any data or literature reference but is assumed to be a reasonable estimate for most puddled soils.

Soil-water tension

```

!----- Calculate moisture suction in kPa
      DO I = 1,NL
!-----If van Genuchten parameters are available
          IF (SWITPF.EQ.1) THEN
!-----Get moisture suction MSUC(I) in cm H2O
              CALL SUWCMS2(I,1,WCST(I),WCL(I),MSUC(I))
!-----If pF curve data are given, use interpolation
          ELSE
!-----Calculate moisture suction MSUC(I) in cm H2O
              IF (WCL(I).GE.WCFC(I)) THEN
                  FACT = MAX(0., &
                              MIN(1.,(WCST(I)-WCL(I))/(WCST(I)-WCFC(I))))
                  MSUC(I) = 10.** (FACT*2.0)
              END IF
          END IF
      END DO

```

```

        IF (WCL(I).GE.WCST(I)) MSUC(I) = 0.
ELSE IF (WCL(I).GE.WCWP(I).AND.WCL(I).LT.WCFC(I)) THEN
    FACT = MAX(0., &
        MIN(1., (WCL(I)-WCWP(I))/(WCFC(I)-WCWP(I))))
    MSUC(I) = 10.** (4.2-FACT*2.2)
ELSE IF (WCL(I).LT.WCWP(I)) THEN
    FACT = MAX(0., &
        MIN(1., (WCL(I)-WCAD(I))/(WCWP(I)-WCAD(I))))
    MSUC(I) = 10.** (7.0-FACT*2.8)
END IF
END IF
!      Note: MSKPA(I) is water moisture suction in kPa!
      MSKPA(I) = (MSUC(I)/10.)
END DO

```

After the soil water contents are computed, the corresponding soil-water tensions (MSUC(I); mbar, or cm H₂O) are calculated. If van Genuchten parameters are available (IF SWITPF.EQ.1), the subroutine SUWCMS2 is used (Section 6.2.4). If these are not available, the soil-water tension (FACT; pF) is calculated from linear interpolation between the user-supplied characteristic points of the pF curve (water content at saturation, WCST, at field capacity, WCFC, at wilting point, WCWP, and at air dryness, WCAD). The soil-water tension in pF value (FACT) is then transformed into the soil-water tension in mbar (MSUC). Finally, the soil-water tension in mbar is transformed into the soil-water tension in kPa (MSKPA).

Water balance check

At the end of the integration section, a water balance check is carried out. First, cumulative amounts of water balance components are calculated.

```

*---- Cumulative amounts
      IRCU = IRCU + IR*DELT
      DRAICU = DRAICU-WLFL(NL+1)*DELT
      UPRICU = UPRICU+ CAPTOT*DELT
      GWCU = GWCU + GWTOT*DELT
      WLOFCU = WLOFCU+ WLOFILL*DELT
      EVSWCU = EVSWCU- EVSW *DELT
      RAINCU = RAINCU+ RAIN *DELT
      RNOFCU = RNOFCU- RUNOF*DELT
      TRWCU = TRWCU - TRW *DELT

!----- Start in main field only when crop is present
      IF ((ESTAB.EQ.'TRANSPLANT'.AND.CROPSTA.GE.3) .OR. &
        (ESTAB.EQ.'DIRECT-SEED'.AND.CROPSTA.GE.1)) THEN
      RUNOFC = RUNOFC - RUNOF*DELT
      RAINC = RAINC + RAIN *DELT
      TRWC = TRWC + TRW *DELT

```

```

EWSWC = EVSWC + EVSW *DELTA
PERCC = PERCC + PERC *DELTA
DRAINC = DRAINC - WLFL(NL+1)*DELTA
END IF

```

Two types of amounts are calculated. Variables with the extension 'CU' indicate cumulative values since the start of the water-balance model, that is, values summed since the model began running at TIME = STTIME (Section 2.2.2). Variables with the extension 'C' indicate cumulative values since the establishment of the crop in the main field, that is, values summed since direct seeding or transplanting. For example, EVSWCU is the cumulative amount of evaporation (mm) since the start of the simulation and EVSWC is the cumulative amount of evaporation (mm) since direct seeding or transplanting of the crop in the main field.

```

!----- Water balance check
WCUM = WCUM+WCUMCH*DELTA

!----- Contribution of profile to water balance, since start
PROREL = WCUMCH
WCUMCO = WCUMCO+PROREL*DELTA

!----- Contribution of surface water to water balance, since start
SURREL = WLOCH+WLOFILL
WLOCO = WLOCO+SURREL*DELTA

!----- Total change in system water content
CKWIN = WCUMCO+WLOCO

!----- Total of external contributions to system water content
CKWFL = IRCU+RAINCU+RNOFCU+ &
        EVSWCU+TRWCU+UPRICU+DRAICU+GWCU+WLOFCU

!----- Check this
CALL SUWCHK(CKWFL,CKWIN,TIME)

```

Changes in soil water content and ponded water depth are compared with inflow and outflow at the boundaries of the soil profile, using the subroutine SUWCHK (ten Berge et al 1992). SUWCHK compares the total change in system water content (CKWIN) with the total of external contributions to system water content (CKWFL). To do so, several intermediate summed variables are calculated first.

6.2.4 Other subroutines used by PADDY

PADDY uses several subroutines that were developed and described by Penning de Vries et al (1989) and ten Berge et al (1992): SUERR, SUWCHK, SUMSKM, and SUWCMS. SUERR checks whether a value of a variable is within a specified domain. SUWCHK checks the soil-water balance by

comparing time-integrated boundary fluxes versus changes in the total amount of water contained in the system. SUMSKM calculates the hydraulic conductivity at a given suction for layer I on the basis of a chosen calculation option. SUWCMS calculates volumetric soil water content from soil water suction and vice versa. Both SUMSKM and SUWCMS were adapted slightly and renamed SUMSK2 and SUWCMS2, respectively. SUWCMS2 uses van Genuchten parameters only; SUMSK2 uses van Genuchten parameters or power functions.

6.3 Irrigation

```

SUBROUTINE IRRIG (ITASK, IUNITD, IUNITL, FILEIT, OUTPUT, &
                  DOY, DELT, CROPSTA, WLO, &
                  NL, WCLQT, MSKPA, IR)

<Declaration of parameters>

IF (ITASK.EQ.1) THEN
!=====
!   Initialization
!=====

!---- Read irrigation data from soil data file
      CALL RDINIT(IUNITD,IUNITL,FILEIT)
!----- Irrigation switch
      CALL RDSINT('SWITIR',SWITIR)
      IF (SWITIR.EQ.1) THEN
          CALL RDAREA('RIRRI',RIRRI,100,IRIRR)
          CALL OUTCOM('Irrigation read from table; SWITIR=1')
      ELSE IF (SWITIR.EQ.2) THEN
          CALL RDSREA('WLOMIN',WLOMIN)
          CALL RDSREA('IRRI',IRRI)
          CALL OUTCOM('Irrigation at minimum water depth; SWITIR=2')
      ELSE IF (SWITIR.EQ.3) THEN
          CALL RDSINT('SLMIN',SLMIN)
          CALL RDSREA('KPAMIN',KPAMIN)
          CALL RDSREA('IRRI',IRRI)
          CALL OUTCOM('Irrigation at min. moist. pressure; SWITIR=3')
      ELSE IF (SWITIR.EQ.4) THEN
          CALL RDSINT('SLMIN',SLMIN)
          CALL RDSREA('WCMIN',WCMIN)
          CALL RDSREA('IRRI',IRRI)
          CALL OUTCOM('Irrigation at min. moist. content; SWITIR=4')
      ELSE IF (SWITIR.EQ.5) THEN
          CALL RDSINT('WLODAY',WLODAY)
          CALL RDSREA('IRRI',IRRI)
          CALL OUTCOM('Irrigation at number of days; SWITIR=5')

```

```

ELSE IF (SWITIR.EQ.0) THEN
    CALL OUTCOM('Rainfed; no irrigation; SWITIR=0')
ELSE
    CALL FATALERR ('IRRIG','Unknown switch for SWITIR in soil
                    file')
END IF
!----- Reading of soil data completed
CLOSE (IUNITD)

```

The subroutine IRRIG computes the daily amount of irrigation (IR; mm d⁻¹) as a function of user-specified criteria. All external input parameters are read from the experimental data file (Section 7.2). First, a switch SWITIR is read that defines whether, and in what manner, irrigation is applied (Table 6.2).

Depending on the value of SWITIR, appropriate irrigation criteria are read:

- SWITIR = 0: the crop grows under rainfed conditions only and no irrigation specifications are required
- SWITIR = 1: an irrigation table RIRRIT that specifies the amount of irrigation applied on specific days
- SWITIR = 2: a lower threshold depth (WLOMIN; mm) of ponded water; a fixed amount of water per irrigation application (IRRI; mm)
- SWITIR = 3: a lower soil-water tension threshold KPAMIN (kPa) in soil layer number SLMIN; a fixed amount of water per irrigation application (IRRI; mm)
- SWITIR = 4: a lower soil water content threshold WCMIN (m³ m⁻³) in soil layer number SLMIN; a fixed amount of water per irrigation application (IRRI; mm)
- SWITIR = 5: a certain number of days after disappearance of ponded water (WLODAY; d); a fixed amount of water per irrigation application (IRRI; mm)

```

IR      = 0.
IRC     = 0.
WLOCNT = 0

```

The following variables are given the initial value of 0: daily irrigation amount (IR; mm d⁻¹), cumulative amount of irrigation since crop establishment (IRC; mm), and a counter for the number of days after the disappearance of ponded water (WLOCNT; d).

```

!=====
!      Rate calculation section
!=====
ELSE IF (ITASK.EQ.2) THEN
!---  Reset irrigation amount at zero every day as default
      IR = 0.

```

Table 6.2. Possible values and meanings of the switch SWITIR.

Value	Meaning
0	No irrigation; rainfed
1	Irrigation supplied as input data
2	Irrigation at critical ponded soil water depth
3	Irrigation at critical soil-water tension
4	Irrigation at critical soil water content
5	Irrigation at x days after disappearance of ponded water

```
!-----Set irrigation for main field (i.e., not in seedbed)
!      Irrigation starts only after direct seeding or at transplanting
      IF (CROPSTA.LT.3) IR = 0.
      IF (CROPSTA.GE.3) THEN
```

The only rate variable calculated is the daily amount of irrigation water, IR (mm d⁻¹). Each day, the amount of irrigation is first reset at 0. Irrigation is taken into account only during the crop growth period in the main field after crop establishment by either direct seeding or transplanting (IF CROPSTA.GE.3). Before that, no irrigation is applied to the main field.

```
!---      Rainfed: no irrigation
      IF (SWITIR.EQ.0) THEN
          IR = 0.
```

If SWITIR = 0, the crop grows under rainfed conditions only and daily irrigation is kept at 0 mm d⁻¹.

```
!---      Irrigation read from table
      ELSE IF (SWITIR.EQ.1) THEN
          IR = LINT2('RIRRIT',RIRRIT,IRIRR,DOY)
```

If SWITIR = 1, daily irrigation values are calculated via linear interpolation from the user-supplied table RIRRIT. Because of the linear interpolation, each irrigation day should be preceded and followed by a day without irrigation (Section 7.2).

```
!---      Irrigation at minimum depth of ponded water
      ELSE IF (SWITIR.EQ.2) THEN
          IF (WLO.LE.WLOMIN) THEN
              IR = IIRRI
          ELSE
              IR = 0.
          END IF
```

If SWITIR = 2, the daily amount of irrigation is determined by the depth of ponded water. A fixed irrigation amount (IIRRI) is given when the ponded

water depth (WL0; mm) drops below the threshold WL0MIN (mm). Otherwise, the amount of irrigation is 0.

```
!---      Irrigation at critical soil-water tension
      ELSE IF (SWITIR.EQ.3) THEN
            IF(MSKPA(SLMIN).GE.KPAMIN) THEN
                  IR = IRR1
            ELSE
                  IR = 0.
            END IF
```

If SWITIR = 3, the daily amount of irrigation is determined by the soil-water tension. A fixed irrigation amount (IRRI) is given when the soil-water tension MSKPA (kPa) in soil layer SLMIN exceeds the threshold KPAMIN (kPa).

```
!---      Irrigation at minimum soil water content
      ELSE IF (SWITIR.EQ.4) THEN
            IF(WCLQT(SLMIN).LE.WCMIN) THEN
                  IR = IRR1
            ELSE
                  IR = 0.
            END IF
```

If SWITIR = 4, the daily amount of irrigation is determined by the soil water content. A fixed irrigation amount (IRRI) is given when the soil water content WCLQT ($\text{m}^3 \text{m}^{-3}$) in soil layer SLMIN drops below the threshold WCMIN ($\text{m}^3 \text{m}^{-3}$).

```
!---      Irrigation at number of days after disappearance of
!      ponded water (defined as 1 mm).
      ELSE IF (SWITIR.EQ.5) THEN
            IF (WL0.LE.1.) THEN
                  IF (WLOCNT.EQ.WL0DAY) THEN
                          IR = IRR1
                          WLOCNT = 0
                  ELSE
                          IR = 0.
                          WLOCNT = WLOCNT + DELT
                  END IF
            ELSE
                  IR = 0.
            END IF
      END IF
END IF
```

If SWITIR = 5, a fixed irrigation amount (IRRI) is given when the cumulative number of days (WLOCNT) after the disappearance of ponded

water exceeds the threshold WLODAY. Each day that the depth of ponded water (WLO) is below 1 mm, the time step DELT is added to the counter WLOCNT.

```

      IF (OUTPUT) THEN
        CALL OUTDAT (2,0,'IR' ,IR )
        CALL OUTDAT (2,0,'IRC',IRC)
      END IF

```

The daily irrigation rate and the cumulative amount of irrigation since crop establishment are written to the output file.

```

!=====!
!   Integration section                               !
!=====!
      ELSE IF (ITASK.EQ.3) THEN
!-----Cumulative amounts in main field when crop is present
      IF (CROPSTA.GE.3) THEN
        IRC  = IRC  + IR*DELT
      END IF

!=====!
!   Terminal calculations                             !
!=====!
      ELSE IF (ITASK.EQ.4) THEN
        CALL OPSTOR ('IRC', IRC)
      END IF

      RETURN
      END

```

The cumulative amount of irrigation since crop establishment (IRC; mm) is calculated by numerical integration with IR, and written to the summary output file OP.DAT (Section 7.7).

7 ORYZA2000 data files

This chapter describes the input and output data files of ORYZA2000. All model parameter values are read from external data files. Different files contain experimental conditions, crop characteristics, soil properties, and weather data (see Table 7.1). The names of these input files are specified in a file called CONTROL.DAT.

The experimental, crop, and soil input data files have identical formats and each variable in these files can appear only once. The rerun file has basically the same syntax, except that it should consist of sets of identical variable names (having different values). The control file contains the names and directories of the data input files (except for the weather data file, which is specified in the experimental data file) and of the generated output files, and controls the format of the generated output files.

Syntax rules of the control, experimental, crop, and soil files are that

- The file consists of variable names and one or more integer, real, double precision, or string values, separated by an = sign. So FPAR = 0.5 is a valid specification, as is WTRDIR = 'PHIL';
- For array variables, more than one value can follow the equal sign, separated by commas or spaces;
- Identical array values can be written as n*<value>;
- Variables can appear in the file in any order as long as their name is unique;
- Comment lines start with * in the first column, or ! in any column (the rest of the line will be ignored);
- The continuation character is a “,” on the preceding line, which applies to arrays only;

Table 7.1. Example input data files for ORYZA2000.

File type	Example	Contents and function
Control	CONTROL.DAT	Names of input and output files to be used, output control settings
Experiment	IRRIDS.T92	Experimental data and conditions (dry season, 1992, at the IRRI farm)
Crop	IR72.DAT	Crop parameters (IR72)
Soil	SIRRI.DAT	Soil properties (IRRI farm)
Weather	PHIL1.992	Daily weather data, location parameters of weather station; at IRRI lowland farm, 1992
Rerun	RERUNS.DAT (optional)	Defines reruns: parameters from input files (experiment, crop, soil), or name(s) of crop, soil, and experimental data files

- The name of a variable cannot exceed 31 characters;
- Names of variables and their numerical values can be given on the same line if separated by a single semicolon “;” (for example, IYEAR=1992; STTIME=4.);
- Only the first 80 characters of each line of the data file are read;
- Supported data types are “real,” “integer,” and “character”;
- Arrays can be organized in tables;
- No tabs, other control, or extended ASCII characters can be used.

These rules are illustrated in the listings of the example input data files as given in the next sections.

7.1 The control file CONTROL.DAT

```
*strun=1
*endrun=2
*-----*
*
*                               CONTROL.DAT
* Run control file for ORYZA2000 model (version 4.0)
*-----*
FILEON = 'RES.DAT'                ! Output file
FILEOL = 'MODEL.LOG'              ! Log file
FILEIR = 'c:\crop-exp\IRRI\RERUNS.DAT' ! Rerun file
FILEIT = 'c:\crop-exp\IRRI\IRRIDS.T92' ! Experimental data
FILEI1 = 'c:\crop-exp\IRRI\IR72.DAT'  ! Crop data
FILEI2 = 'c:\crop-exp\IRRI\SIRRI.DAT'  ! Soil data
```

The CONTROL.DAT is the only file with a predefined name. First, it lists file names that are used to define input and output files of the model, along with the directory path where they are stored. In the above example, the model output file RES.DAT and the log report MODEL.LOG will be written in the same directory as where the model ORYZA2000 is located. All defined input data files (RERUNS.DAT, IRRIDS.T92, IR72.DAT, and SIRRI.DAT) are stored in the subdirectory C:\CROP-EXP\IRRI. The CONTROL.DAT file itself should be located in the same directory as the model ORYZA2000 (see also Sections 8.1.2 and 8.1.3 on the installation of ORYZA2000). Note that the weather data file is not specified in CONTROL.DAT; this is done in the experimental data file (Section 7.2). Also, the start (strun) and end rerun (endrun) numbers as specified in the rerun file (Section 7.6) are defined. These parameters are optional and can also be removed. In that case, all reruns specified in the rerun file are executed. When new input (or rerun) data files have been created by the model user, the example file names given here should be replaced by these new file names. After the listing of file names, options can be specified regarding the format of the data in the output file (here called RES.DAT).

```

*-----
* Set output/print options
*-----
PRDEL = 1.      ! Output time step (day)

```

The real variable PRDEL (d) indicates the interval of output writing during a dynamic simulation. For example, when PRDEL = 5., output is written every five days, starting on the first day of the simulation. Output of the model to the file can be fully suppressed by PRDEL = 0. When PRDEL >0, output is always given at the start of the simulation (TIME = STTIME) and when the simulation is terminated (either when TIME = FINTIM or some other finish criterion is met). By giving PRDEL a high value (e.g., 1000.), all intermediate outputs between the start and end simulation are suppressed.

```

IPFORM = 5      ! Code for output table format:
                ! 4 = spaces between columns
                ! 5 = tabs between columns (spreadsheet output)
                ! 6 = two-column output

```

The integer variable IPFORM defines whether an output table is required and, if so, what the format should be:

- IPFORM = 0 means no output table is given.
- IPFORM = 4 means a (space-delimited) multiple column table is created (convenient for normal printing and viewing).
- IPFORM = 5 means a tab-delimited column table is created (convenient for a spreadsheet, such as EXCEL, or graphics programs).
- IPFORM = 6 generates a two-column format.

```

DELTMP = 'N'    ! Switch variable indicates what should be done with the
                ! temporary output file ('N' = do not delete,
                ! 'Y' = delete)

```

The character variable DELTMP defines whether the file that contains temporary model output (RES.BIN) should be deleted at the termination of the simulation:

- DELTMP = 'N' means do not delete.
- DELTMP = 'Y' means delete.

The temporary file is constructed during the dynamic phase of the simulation and is read during the terminal phase of the simulation to generate the output file (RES.DAT). The temporary file is not of great value for normal purposes and can be deleted. However, there is the option of generating graphs directly from the RES.BIN file after termination of the simulation with the TTSELECT program (van Kraalingen 1995; Sections 8.1.2 and 8.1.3). For this special purpose, the temporary file should not be deleted (DELTMP='N').

```

COPINF = 'N'    ! Switch variable indicates whether to copy the input files
                ! to the output file ('N' = do not copy, 'Y' = copy)

```

The character variable COPINF determines whether the input files mentioned in the CONTROL.DAT file must be copied to the output file (so that the input data files are combined with the output they produce):

COPINF = 'Y' means that input files are copied to the output file after writing the simulation results.

COPINF = 'N' means that the input files are not copied into the output file.

```
PRSEL = 'TIME', 'TRC', 'EVSC'
! The string array PRSEL contains the output variables for which
! formatted tables have to be made. One or more times,
! a series of variable names terminates with the word <TABLE>.
! The translator writes the variables in each PRINT statement to
! a separate table
```

The (optional) character variable PRSEL can be used to select a subset out of the normal output variables without having to change the model. With PRSEL, several tables can be generated one after the other. The example given here generates a table with TRC (potential crop transpiration) and EVSC (potential soil evaporation) in columns. The variable TIME (days from the start of the simulation) is printed in this table as the first (independent) variable.

```
IOBSD = 1991,182
! List of observation data for which output is
! required. The list should consist of pairs such as
! <year>, <day> combination
```

The (optional) integer variable IOBSD can be used to force output on days on which observations were made. In many cases, these observation dates will not coincide with output intervals defined by PRDEL, unless PRDEL is set at 1 day. The IOBSD variable should be specified as a list of <observation_year>, <observation_day> combinations. A maximum of 50 <year, day> combinations can be defined here.

```
IFLAG = 1101 ! Indicates where weather error and warnings
! go (1101 means errors and warnings to log
! file, errors to screen, see FSE manual)
```

The variable IFLAG specifies what should be done with error and warning messages from the weather system. IFLAG is an integer variable consisting of four digits (see Table 7.2).

For example, IFLAG = 1101 (the default value) means that warnings and errors go to the log file (whose name was specified in CONTROL.DAT). In this case, warnings are not sent to the screen, but errors are sent to the screen.

Table 7.2. Explanation of IFLAG variable values.

Digit	Value	
	0	1
First	Warnings don't go to log file	Warnings go to log file
Second	Errors don't go to log file	Errors go to log file
Third	Warnings don't go to screen	Warnings go to screen
Fourth	Errors don't go to screen	Errors go to screen

7.2 The experimental data file

```

*-----*
* Experimental data file                                     *
*                                                         *
* File name       : IRRIDS.T92                             *
* Crop            : Oryza sativa cv. IR72                 *
* Year/Season     : 1992, dry season                       *
* Experimental site: IRRI farm, 14.22N, 121.25E, 23m      *
* Fertilizer      : 225 kg N                               *
*                 60 (transpl), 60 (mid-til), 60 (PI), 45 (flow) *
* Researchers     : Kropff/Cassman/Liboon/Torres         *
*-----*

```

The experimental data file contains information on the run modes of ORYZA2000, the site and experimental conditions of the simulation run, and any observed variables. After the header (which should contain basic information on the conditions simulated), the first information to be provided concerns the run modes of ORYZA2000.

```

*-----*
* 1. Selection of modes of running                         *
*-----*
*--  RUNMODE: mode of running ORYZA
RUNMODE = 'EXPERIMENT'      ! ORYZA simulates an experiment
*RUNMODE = 'EXPLORATION'   ! ORYZA used for exploration

```

The character variable switch RUNMODE determines whether a particular experiment is simulated or a model extrapolation is made. In the last case, the day (EMD; d) and year (EMY; y) of crop emergence are automatically set at the start time (STTIME; d) and year (IYEAR; y) of simulation. Examples of model extrapolations are reruns on emergence day to study the effect of cropping schedule (Bouman et al 1993a). Setting the emergence date at the start date ensures that a model is never started after a given emergence date. Users of ORYZA2000 can select one of the two RUNMODE options by removing the asterisk for their preferred choice and inserting an asterisk in front of the discarded option.

```

*--  PRODENV = Production situation setting
*PRODENV = 'POTENTIAL'           ! Potential production
PRODENV = 'WATER BALANCE'       ! Production may be water-limited

```

The character variable switch PRODENV determines whether ORYZA2000 is run in the potential production mode (PRODENV = 'POTENTIAL') with respect to water, or with a dynamic water-balance module (PRODENV = 'WATER BALANCE'). Table 7.3 lists the combination of modules that is executed as determined by the setting of this switch. When PRODENV = 'WATER BALANCE', a soil data file needs to be supplied at FILEI2 in the CONTROL.DAT file; if PRODENV = 'POTENTIAL', no soil data file needs to be provided and an asterisk can be put in front of FILEI2 = '...' in the CONTROL.DAT file. Also, when PRODENV = 'WATER BALANCE', information on irrigation water management should be provided in the experimental data file under Section 6 (see below).

```

*--  NITROENV = Nitrogen production situation setting
*NITROENV = 'POTENTIAL'         ! Potential production
NITROENV = 'NITROGEN BALANCE'   ! Production may be nitrogen-limited

```

```

* WARNING: Nitrogen and water limitations at the same time is as
*           yet an unvalidated option in ORYZA2000!!!!

```

The character variable switch NITROENV determines whether ORYZA2000 is run in the potential production mode (NITROENV = 'POTENTIAL') with respect to nitrogen, or whether the nitrogen dynamics should be simulated (NITROENV = 'NITROGEN BALANCE') (Table 7.3). When NITROENV = 'NITROGEN BALANCE', information on soil nitrogen supply and nitrogen fertilization should be provided in the experimental data file under Section 7 (see below). A warning is given for the combination of “water-limited situation” with “nitrogen-limited situation”: although ORYZA2000 was extensively tested and validated for conditions of water-limited and nitrogen-limited production separately, it was not tested or validated for conditions of combined water and nitrogen limitations.

```

*--  ETMOD is method for evapotranspiration calculation:
ETMOD = 'PENMAN'                 ! Penman-based
*ETMOD = 'PRIESTLY TAYLOR'       ! Priestly-Taylor
*ETMOD = 'MAKKINK'              ! Makkink

```

The character variable switch ETMOD determines the evapotranspiration module to be used: Penman, Priestley-Taylor, or Makkink (Section 4.1). The Penman equations are the most accurate ones and are the preferred module. However, the Penman module requires many weather variables that may not always be available: daily values of irradiation (RDD; $\text{kJ m}^{-2} \text{d}^{-1}$) or sunshine hours (h d^{-1}), minimum temperature (TMMN; $^{\circ}\text{C}$), maximum temperature

Table 7.3. ORYZA2000 modules executed and input data files required as a function of run mode switch settings in the experimental data file. See also Section 2.2.1.

PRODENV	NITROENV	Modules called	Input files needed
Potential	Potential	ORYZA1, ET, WNOSTRESS, NNOSTRESS	Experimental, crop, weather
Water balance	Potential	ORYZA1, ET, WSTRESS, IRRIG, PADDY, NNOSTRESS	Experimental, crop, soil, weather
Potential	Nitrogen balance	ORYZA1, ET, WNOSTRESS, NCROP, NSOIL	Experimental, crop, weather
Water balance	Nitrogen balance	ORYZA1, ET, WSTRESS, IRRIG, PADDY, NCROP, NSOIL	Experimental, crop, soil, weather

(TMMX; °C), early morning vapor pressure (VP; kPa), and mean wind speed (WN; m s⁻¹). If only irradiation or sunshine hours and minimum and maximum temperature are available, the Priestley-Taylor or Makkink module can be selected. See also the comments on the selection of evapotranspiration modules in Sections 2.2.2 and 4.1.

```

*-----*
* 2. Timer data for simulation                                     *
*-----*
IYEAR = 1992          ! Start year of simulation (y)
STTIME = 4.          ! Start time (d; day number)
FINTIM = 1000.       ! Finish time (d; days after start of simulation)
DELT = 1.            ! Time step (d)

```

The start year (IYEAR; y) and start day (STTIME; day number of year) determine the start of the ORYZA2000 model. The modules that are started are ET and ORYZA1, and, depending on the run mode settings, the ones for water and nitrogen dynamics (Table 7.3). Note that actual crop growth takes place only when the internal timer (TIME; d) of ORYZA2000 has reached the date of emergence (see “4. Establishment data” below). FINTIM (d) determines at how many time steps (days) after simulation the model should stop. By setting FINTIM at a very high value, the user ensures that ORYZA2000 completes a whole crop growth cycle as determined by the stop condition DVS = 2. (indicating maturity of the crop; Section 3.3). DELT is the time step of integration and should always be 1 day.

```

*-----*
* 3. Weather station and climatic data for simulation           *
*-----*
WTRDIR = 'C:\ORYZA\DATA\WEATHER\' ! Directory of weather data
CNTR = 'PHIL'                       ! Country code (-)

```

```

ISTN      = 1                ! Station code (-)

ANGA = 0.29                ! Angstrom A parameter (-)
ANGB = 0.45                ! Angstrom B parameter (-)

* Table of temperature increase (oC; Y value) as a function of
* day number (d; X value):
TMCTB = 0., 0.,
        366., 0.

FAOF = 1. ! Multiplication factor for potential evapotranspiration (-)

TMPSB = 0. ! Temperature increase in seedbed because of cover (oC):
        ! 0. when no cover; 9.5 with cover

```

WTRDIR specifies the directory in which the weather file is located. The name of a weather data file should consist of three “elements,” defined by the following variables (see also Section 7.5):

- CNTR Country code (value to be supplied as character)
- ISTN Station number (value to be supplied as integer)
- IYEAR Year indication (value to be supplied as integer)

In the definition of a weather data file in the experimental data file, these three elements are addressed separately. The country code consists of a four-character code (letters) and the station number has one or two digits. The year indication is taken from the last three numbers of the IYEAR variable (also indicating the start year of the simulation; see above). For instance, the name of a weather data file for the year (IYEAR) 1992, country code (CNTR) ‘PHIL’, and station code (ISTN) 1 is ‘PHIL1.992’. For this example, a weather data file with this name should be present in the subdirectory as indicated by the variable WTRDIR to run the model.

ANGA and ANGB are the Ångström A and B parameters. These parameters are used in the Penman calculations of evapotranspiration. Indicative values in relation to broad climatic regions are given in Table 2.1 (Section 2.3).

The temperature adjustment table (TMCTB) specifies a temperature increase in the temperature values read in the weather data file. TMCTB is a table of day number (d; first column) and temperature increase (°C; second column). This array can be used to study the effects of temperature changes caused by global climate change.

The temperature correction factor (TMPSB; °C) specifies a temperature increase during the seedbed stage of transplanted rice caused by the presence of a plastic cover (Section 3.2). If no such cover is present, TMPSB should be 0 °C. In Japan, the use of a plastic cover raises the maximum temperature by 9 °C (T. Horie, personal communication).

```

*-----*
* 4. Establishment data
*-----*

```

```

*-- ESTAB is method of establishment: 'TRANSPLANT' or 'DIRECT-SEED':
ESTAB='TRANSPLANT'
*ESTAB='DIRECT-SEED'

* Transplanting date January 16, 1992; sowing date Jan. 4.
EMD   = 4      ! Day of emergence (either direct or in seedbed) (d)
EMYR  = 1992   ! Year of emergence (y)
SBDUR = 12     ! Seedbed duration (from sowing to transplanting) (d)

```

The character variable switch ESTAB defines whether the rice crop is transplanted or direct-seeded. EMD (d) is the calendar day of emergence of the crop either in the seedbed (if transplanted) or in the main field (if direct-seeded). EMYR (y) is the year of emergence. Note that the day and year of emergence should be equal to or greater than the start time (STTIME; d) and year (IYEAR; y) of the simulation run supplied earlier. If this is not the case, ORYZA2000 will produce an error message and not execute the simulation (Section 2.2.2). For transplanted rice, the seedbed duration should be supplied (SBDUR; d). Note that the day of transplanting does not have to be supplied, but is calculated in ORYZA2000 as the day of emergence (EMD) plus the seedbed duration (SBDUR). For direct-seeded rice, the value of SBDUR is not read from the file but is set at 0 by the ORYZA2000 model.

```

*-----*
* 5. Management parameters *
*-----*
NPLH  = 5.     ! Number of plants per hill (pl hill-1)
NH    = 25.    ! Number of hills (no m-2)
NPLSB = 1000. ! Number of plants in seedbed (pl m-2)
NPLDS = 200.  ! Number of plants direct-seeded in main field (pl m-2)

```

For transplanted rice, the number of plants per hill (NPLH; number hill⁻¹), the number of hills per square meter (NH; number m⁻²), and the number of plants in the seedbed per square meter (NPLSB; number m⁻²) should be supplied. When the crop is direct-seeded, these parameters are not read by ORYZA2000, but the number of plants that are seeded per square meter in the main field (NPLDS; number m⁻²) should be supplied.

```

*-- Initial data at emergence
LAPE  = 0.0001 ! Initial leaf area per plant (m2 plant-1)
DVSI  = 0.0    ! Initial development stage (-)
WLVGI = 0.0    ! Initial leaf weight (kg ha-1)
WSTI  = 0.0    ! Initial stem weight (kg ha-1)
WRTI  = 0.0    ! Initial root weight (kg ha-1)
WSOI  = 0.0    ! Initial weight of storage organs (kg ha-1)
ZRTI  = 0.0001 ! Initial root length (m)

```

Next, some initialization parameters are given: the weights of leaves (WLVGI; kg ha⁻¹), stems (WSTI; kg ha⁻¹), roots (WRTI; kg ha⁻¹), and storage

organs (WSOI; kg ha⁻¹), and the development stage (DVSI; -), leaf area per plant (LAPE; m² plant⁻¹), and root depth (ZRTI; m) at the time of emergence. To start crop growth, the initial leaf area and rooting depth are set at a small value; all other parameters are set at 0.

```
*-- Reinitialization at transplanting
ZRTTR = 0.05      ! Root length at transplanting (m)
```

ORYZA2000 simulates root growth in the seedbed with the same equations as in the main field. However, seedbed conditions may differ from those in the main field and the root depth of the seedlings should be reinitialized at the time of transplanting (ZRTTR; m).

```
*-----*
* 6. Irrigation switch:
*   Needs to be filled in only when PRODENV = 'WATER BALANCE'
*-----*
** Select from the following options:
*SWITIR = 0 ! No irrigation; rainfed
*SWITIR = 1 ! Irrigation supplied as input data
SWITIR = 2 ! Irrigation at minimum ponded soil water depth
*SWITIR = 3 ! Irrigation at critical soil-water tension
*SWITIR = 4 ! Irrigation at critical soil water content
*SWITIR = 5 ! Irrigation at X days after disappearance of ponded water

* If SWITIR = 1, supply a table with amount of irrigation (mm; Y value)
* as a function of day number (d; X value):
*RIRRIT = 0., 20.,
*         366., 20.

** If SWITIR = 2-5, supply amount of irrigation IRRI (mm)
IRRI = 75. ! Irrigation application (mm)

** If SWITIR = 2, supply minimum ponded water depth WLOMIN (mm)
** below which irrigation water is applied
WLOMIN = 10. ! Minimum ponded water depth (mm)

** If SWITIR = 3-4, supply critical soil-water tension KPAMIN (kPa)
** (for SWITIR=3) or critical soil water content WCMIN (m3 m-3)
** (SWITIR=4) at which irrigation water is applied, and the number
** of the soil layer to which this critical level applies, SLMIN (-)
KPAMIN = 100. ! Critical soil-water tension (kPa)
*WCMIN = 0.30 ! Critical soil water content (m3 m-3)
SLMIN = 3 ! Soil layer for which KPAMIN or WCMIN applies (-)

** If SWITIR = 5, supply the number of days after disappearance of
** ponded water (WLODAY), at which irrigation water is applied (d)
WLODAY = 3 ! number of days after disappearance of ponded water (d)
```

The management of irrigation water must be defined when ORYZA2000 is run with a dynamic water balance (if the switch PRODENV = 'WATER BALANCE'; see above). In the potential production mode with respect to water (PRODENV = 'POTENTIAL'), this section can be skipped since none of these parameters are then read by ORYZA2000.

The switch SWITIR defines the use of irrigation water. If its value is 0, no irrigation is applied and only rainfall is an input in the soil-water balance. All other values of SWITIR indicate that irrigation water is applied:

- When SWITIR is 1, the irrigation input should be provided by the user as an input table called RIRRIT. This table is an array of day number and irrigation amount (in mm). ORYZA2000 interpolates irrigation amounts at each day of simulation between two subsequent days. For example, if an irrigation amount of 10 mm is given on day 10 and 50 mm on day 30 (with no irrigation on all other days), RIRRIT = 1.,0., 9.,0., 10.,10., 11.,0., 29.,0., 30.,50., 31.,0., 365.,0. In each data pair, the first value is the day number and the second the irrigation amount.
- When SWITIR has values from 2 to 5, a fixed, user-defined amount of irrigation is given each time a certain threshold level is reached during the simulation. In these cases, the timing of the irrigation application is computed by ORYZA2000. The fixed irrigation application is set by the parameter IRRI (mm). When SWITIR is 2, this irrigation amount is applied each time the simulated depth of ponded water in the field drops below the user-defined threshold level WL0MIN (mm). When SWITIR is 3, the irrigation amount IRRI is applied each time the simulated soil-water tension is higher than a user-defined threshold level KPAMIN (kPa). When SWITIR is 4, the irrigation amount IRRI is applied each time the simulated soil water content is lower than a user-defined threshold level WCMIN ($\text{m}^3 \text{m}^{-3}$). In both cases when SWITIR is 3 or 4, the soil layer SLMIN (-) at which the threshold levels apply should also be supplied in the data file. The number of soil layers is defined in the soil data file (Section 7.4). When SWITIR is 5, the irrigation amount IRRI is applied each time at a certain number of days after the disappearance of (simulated) ponded water on the surface of the field. This number of days is defined by the parameter WL0DAY (d).

```

*-----*
* 7. Nitrogen parameters *
*-----*
* Table of fertilizer nitrogen recovery fraction (-; Y value) as a
* function of development stage (-; X value):
REC NIT =
0.0, 0.30,
0.2, 0.35,
0.4, 0.50,
0.8, 0.75,

```

```
1.0, 0.75,  
2.5, 0.75
```

```
SOILSP = 0.8 ! Soil N mineralization rate (kg N ha-1 d-1)
```

```
* Table of nitrogen fertilizer application rate (kg N ha-1 d-1; Y value)  
* as a function of days after emergence (d; X value):
```

```
FERTIL =  
0., 0.,  
1., 0.,  
11., 0.,  
12., 60.,  
13., 0.,  
29., 0.,  
30., 60.,  
31., 0.,  
66., 0.,  
67., 60.,  
68., 0.,  
94., 0.,  
95., 45.,  
96., 0.,  
366., 0.
```

Input of nitrogen fertilizer application and soil nitrogen supply should be given when ORYZA2000 is run with a dynamic nitrogen balance (if the switch NITROENV = 'NITROGEN BALANCE'; see above). If the production mode with respect to nitrogen is potential (NITROENV = 'POTENTIAL'), this section can be skipped since none of these parameters are then read by ORYZA2000.

The soil mineralization rate SOILSP (kg N ha⁻¹ d⁻¹) is the amount of nitrogen that is available daily for uptake from the soil through mineralization. The value of SOILSP can be estimated crudely from zero-N experiments: divide the total amount of N taken up by a crop under zero-N fertilizer application by the crop growth duration during which N is taken up by the crop.

The N fertilizer application should be provided as an input table called FERTIL. This table is an array of date and fertilizer N amount (kg N ha⁻¹ d⁻¹). ORYZA2000 interpolates fertilizer N amounts on each day of simulation between two relevant dates. For example, if a fertilizer N amount of 25 kg ha⁻¹ is given on day 10 and 50 kg ha⁻¹ on day 30, FERTIL = 1.,0., 9.,0., 10.,25., 11.,0., 29.,0., 30.,50., 31.,0., 365.,0. In each data pair, the first value is the date and the second the fertilizer N amount.

The recovery of fertilizer N should be provided as an input table called RECINIT. This table is an array of development stage and recovery fraction. ORYZA2000 interpolates recovery fractions on each day of simulation

between two relevant development stages. In the example table above, the recovery fraction gradually increases from 0.3 at emergence to 0.75 just before flowering and thereafter. In each data pair, the first value is the development stage and the second the recovery fraction. The recovery fraction can be calculated from field experiments with different N application rates: it is the difference between N uptake by the crop at a certain N fertilizer application rate and at zero-N fertilizer application divided by the N fertilizer rate.

```

*-----*
* 8. Measured data for model calibration and comparison *
*   and an option to force measured LAI during simulation *
*   (instead of using simulated values) *
*-----*
* Observed phenology: required only if program DRATES is run!!
IDOYTR = 16   ! Day of transplanting (give 0 if direct-seeded) (d)
IYRTR  = 1992 ! Year of transplanting (give 0 if direct-seeded) (y)
IDOYPI = 58   ! Day of panicle initiation
           ! (give -99 if not observed) (d)
IYRPI  = 1992 ! Year of panicle initiation
           ! (give -99 if not observed) (y)
IDOYFL = 83   ! Day of flowering (d)
IYRFL  = 1992 ! Year of flowering (y)
IDOYM  = 114  ! Day of maturity (d)
IYRM   = 1992 ! Year of maturity (y)

* Measured leaf area index (LAI; m2 leaf m-2 soil): first column gives
* year, second column gives day number, third column gives the measured
* LAI at that date (day and year):
LAI_OBS =
1992.,  4.,  0.00,
1992., 16.,  0.03,
1992., 34.,  0.46,
1992., 58.,  5.22,
1992., 68.,  5.97,
1992., 83.,  5.88,
1992., 97.,  4.82,
1992.,114.,  2.45

*-- Parameter to select forcing of measured LAI during simulation
LAI_FRC = 0      ! No forcing
*LAI_FRC = 2     ! Forcing

* Measured green leaf dry weight (WLVG; kg ha-1): first column gives
* year, second column gives day number, third column gives the measured
* WLVG at that date (day and year):
WLVG_OBS =
1992.,  4.,  0.,
1992., 16.,  6.,

```

1992., 34., 138.,
1992., 58., 1874.,
1992., 68., 2840.,
1992., 83., 3030.,
1992., 97., 2828.,
1992., 114., 1432.

* Measured dead leaf dry weight (WLVD; kg ha-1): first column gives
* year, second column gives day number, third column gives the measured
* WLVD at that date (day and year):

WLVD_OBS =
1992., 4., 0.,
1992., 16., 0.,
1992., 34., 0.,
1992., 58., 47.,
1992., 68., 234.,
1992., 83., 660.,
1992., 97., 1448.,
1992., 114., 2269.

* Measured stem dry weight (WST; kg ha-1): first column gives
* year, second column gives day number, third column gives the measured
* WST at that date (day and year):

WST_OBS =
1992., 4., 0.,
1992., 16., 5.,
1992., 34., 109.,
1992., 58., 1577.,
1992., 68., 2902.,
1992., 83., 4771.,
1992., 97., 4373.,
1992., 114., 4243.

* Measured panicle dry weight (storage organ)(WSO; kg ha-1): first column
* gives year, second column gives day number, third column gives the
* measured WSO at that date (day and year):

WSO_OBS =
1992., 4., 0.,
1992., 16., 0.,
1992., 34., 0.,
1992., 58., 0.,
1992., 68., 0.,
1992., 83., 1558.,
1992., 97., 5932.,
1992., 114., 9843.

* Measured total dry weight (WAGT; kg ha-1): first column gives
* year, second column gives day number, third column gives the measured

* WAGT at that date (day and year):

```
WAGT_OBS =
1992., 5., 0.,
1992., 16., 11.,
1992., 34., 247.,
1992., 58., 3498.,
1992., 68., 5976.,
1992., 83., 10019.,
1992., 97., 14580.,
1992., 114., 17787.
```

* Measured leaf N content on weight basis (FNLV; g N g⁻¹ leaf DM): first
* column gives year, second column gives day number, third column gives
* the measured FNLV at that date (day and year):

```
FNLV_OBS =
1992., 4., 0.027,
1992., 16., 0.027,
1992., 34., 0.051,
1992., 58., 0.034,
1992., 68., 0.033,
1992., 83., 0.025,
1992., 97., 0.023,
1992., 114., 0.014
```

* Measured leaf N content on area basis (NFLV; g N m⁻² leaf area): first
* column gives year, second column gives day number, third column gives
* the measured NFLV at that date (day and year):

```
NFLV_OBS =
1992., 4., 0.54,
1992., 16., 0.54,
1992., 34., 1.53,
1992., 58., 1.22,
1992., 68., 1.56,
1992., 83., 1.29,
1992., 97., 1.37,
1992., 114., 0.83
```

*-- Parameter to select forcing of measured NFLV values during simulation

```
NFLV_FRC = 0 ! No forcing
```

```
*NFLV_FRC = 2 ! Forcing
```

The last section of the experimental data file is completely optional and contains field observations. Most of these data are not used by ORYZA2000, but are merely repeated in the generated output files for easy comparison between observed and simulated variables. If observations on certain or all of the listed variables are not available, these variables can be removed from the data file.

The observations on phenology (years and dates of transplanting, panicle initiation, flowering, and physiological maturity) are not used at all by ORYZA2000. They are used by the parameterization program DRATES to derive the development rate parameters (Section 8.2).

The observations on all other variables are given in tables in a fixed form: the first column gives the year of observation, the second the date of observation, and the third the observed value of the variable. The name of the variable is the same as the name used in the simulation modules of ORYZA2000, but it has the suffix “_OBS”. Observed values can be given for green leaf weight (WLVG; kg dry matter ha⁻¹), dead leaf weight (WLVD; kg dry matter ha⁻¹), stem weight (WST; kg dry matter ha⁻¹), panicle weight (WSO; kg dry matter ha⁻¹), total aboveground biomass (WAGT; kg dry matter ha⁻¹), leaf area index (LAI; m² leaf m⁻² soil), leaf N content on a weight basis (FNLV; g N g⁻¹ leaf), and leaf N content on an area basis (NFLV; g N m⁻² leaf). These observed values can also be used by the parameterization program PARAM (Section 8.2). For that use, all the weight observations should be made on the same dates and preferably also for the leaf area index.

The observed values of leaf area index (LAI_OBS) and of leaf N content on a weight basis (FNLV_OBS) can be used optionally in ORYZA as a forcing function. In that case, the simulated values of these variables are overruled with daily interpolated values of these variables (Section 3.3 for LAI; Section 5.3 for FNLV). The choice of using observed values as a forcing function is defined by the parameter LAI_FRC for LAI and by FNLV_FRC for FNLV. If the value of this parameter is 0, no overruling of the simulated values takes place; if the value is 2, overruling with interpolated values will take place. When _FRC is 2, ORYZA2000 will use simulated values until the first observation date is reached. On that date, the simulated variable is reset to the observed value. From then on, daily interpolated values will be used until the last observation. After that, ORYZA2000 will again use simulated values until the end of the simulation.

7.3 The crop data file

```

*****
* Crop data file for ORYZA2000 rice growth model *
* File name : IR72.D92 *
* Crop : Oryza sativa cv. IR72 *
* Experiment : Parameter values derived from various experiments *
* at IIRRI, Los Banos, Philippines. *
* Information : Bouman BAM, Kropff MJ, Tuong TP, Wopereis MCS, ten *
* Berge HFM, van Laar HH. 2001. *
* ORYZA2000: modeling lowland rice. *
* International Rice Research Institute, Los Banos. *
*****

```

The crop data file contains all the parameter values that characterize the rice crop. The header should name the variety under consideration and give some information on the experiment from which the parameter values were derived. Most parameter values can be used in a general sense for rice, but some are variety-specific. Section 8.2 presents two programs (DRATES and PARAM) that can be used to estimate the most important variety-specific parameters. The parameters given in this example data file are mostly based on various published and unpublished experiments using IR72 conducted at IRRI between 1991 and 1993.

* 1. Phenological development parameters

```
TBD = 8.          ! Base temperature for development (oC)
TBLV = 8.         ! Base temperature for juvenile leaf area growth (oC)
TMD = 42.         ! Maximum temperature for development (oC)
TOD = 30.         ! Optimum temperature for development (oC)
DVRJ = .000773   ! Development rate in juvenile phase (oCd-1)
DVRI = .000758   ! Development rate in photoperiod-sensitive phase (oCd-1)
DVRR = .000784   ! Development rate in panicle development (oCd-1)
DVRP = .001784   ! Development rate in reproductive phase (oCd-1)
MOPP = 11.50     ! Maximum optimum photoperiod (h)
PPSE = 0.0       ! Photoperiod sensitivity (h-1)
SHCKD = 0.4      ! Relation between seedling age and delay in
                  ! phenological development (oCd oCd-1)
```

The dimensionless scale for development is used (Section 3.2.1). From experimental data, the development rate (DVR, $(^{\circ}\text{Cd})^{-1}$) can be calculated as the inverse of the number of heat units between two phenological events. The values for the cardinal temperatures (TBD, TBLV, TMD, and TOD; $^{\circ}\text{Cd}$) have been estimated based on Gao et al (1992), Summerfield et al (1992), Yin (1996), and unpublished data from Ingram et al. Four variety-specific development rates have to be estimated for the effect of temperature in the different stages:

- DVRJ for the basic vegetative phase, from sowing (DVS = 0) to the start of the photoperiod-sensitive phase (DVS = 0.4).
- DVRI for the photoperiod-sensitive phase, from the end of the basic vegetative phase to panicle initiation (DVS = 0.65). DVRI is the development rate at optimum photoperiod.
- DVRP for the panicle formation phase, from panicle initiation to first flowering (DVS = 1).
- DVRR for the grain-filling phase, from first flowering to physiological maturity (DVS = 2).

The variety-specific development rate constant is the inverse of the temperature sum required to complete a specific phase at the optimum photoperiod. Differences between varieties in total crop duration are usually caused by differences in the duration of the vegetative phase (DVRJ) rather

than the other phases (Vergara and Chang 1985). Section 8.2 explains how the program DRATES can be used to calculate the development rates from specific field experiments.

The photoperiod sensitivity of a variety is indicated with the parameters MOPP (optimum photoperiod; h) and PPSE (photoperiod sensitivity; h⁻¹), which indicates the decrease in the developmental rate at photoperiods higher than the optimum during the photoperiod-sensitive phase. Most IR varieties are slightly photoperiod-sensitive and therefore the parameter PPSE is set at 0. The parameter SHCKD indicates the delay in flowering (°Cd) per °Cd of seedling age because of the transplanting shock. See Section 3.2.1 (“Phenological development”) and Figures 3.3 and 3.4 for a further explanation on how to derive SHCKD from field experiments.

* 2. Leaf and stem growth parameters

```
RGRLMX = 0.0085 ! Maximum relative growth rate of leaf area (oCd-1)
RGRLMN = 0.0040 ! Minimum relative growth rate of leaf area (oCd-1)
SHCKL  = 0.25   ! Relation between seedling age and delay in leaf area
                ! development (oCd oCd-1)
```

```
* Switch to use SLA as table (give values below) or as fixed function
SWISLA = 'FUNCTION' ! Give function parameters ASLA,BSLA,CSLA,DSLA,SLAMAX
*SWISLA = 'TABLE'   ! Give SLA as a function of DVS in the table SLATB
```

* If SWISLA = 'FUNCTION', supply SLA function parameters:

* SLA = ASLA + BSLA*EXP(CSLA*(DVS-DSLA)), and SLAMAX

```
ASLA   = 0.0024 ! (-)
BSLA   = 0.0025 ! (-)
CSLA   = -4.5   ! (-)
DSLA   = 0.14  ! (-)
SLAMAX = 0.0045 ! maximum value of SLA (ha/kg)
```

* If SWISLA = 'TABLE', supply table of specific leaf area

* (ha kg⁻¹; Y value) as a function of development stage (-; X value):

```
SLATB = 0.00, 0.0045,
        0.16, 0.0045,
        0.33, 0.0033,
        0.65, 0.0028,
        0.79, 0.0024,
        2.10, 0.0023,
        2.50, 0.0023
```

* Table of specific green stem area (ha kg⁻¹; Y value) as a function of
* development stage (-; X value):

```
SSGATB = 0.0, 0.0003,
         0.9, 0.0003,
         2.1, 0.0000,
         2.5, 0.0000
```

In the early phases, leaf area growth proceeds more or less exponentially, the relative growth rate being approximately linearly related to temperature (Section 3.2.9; Eqn. 3.37). When leaf area per plant is plotted on a logarithmic scale ($\ln(\text{LAI})$) versus the temperature sum after emergence, a more or less linear relationship is obtained (see Fig. 3.12). The slope measures the relative leaf area growth rate (R_i , RGRL; $^{\circ}\text{Cd}^{-1}$). The transplanting shock (TSHCKL) causes a delay in leaf growth, but does not affect the slope RGRL. A maximum value of 0.0085 (RGRLMX; $^{\circ}\text{Cd}^{-1}$) was derived from high N experiments at IRRRI (Los Baños, Philippines) and a minimum of 0.0040 (RGRLMN; $^{\circ}\text{Cd}^{-1}$) from zero-N treatments. The program PARAM (Section 8.2) can help calculate RGRL values from experimental data.

In the phase of linear growth, the variable specific leaf area (SLA; $\text{m}^2 \text{ leaf kg}^{-1} \text{ leaf}$) is required as an input. The SLA is considered variety-specific and should be determined empirically as a function of the development stage (DVS) from field experiments. There are two options to supply SLA: by a table of SLA as a function of DVS (SWILAI = 'TABLE') or by function parameters that relate SLA to DVS (SWILAI = 'FUNCTION'). If the table option is chosen, the table SLATB should be supplied: the first column gives the development stage and the second the corresponding SLA value. If the function option is chosen, the parameter values of the function

$$\text{SLA} = \text{ASLA} + \text{BSLA} * \text{EXP}(\text{CSLA} * (\text{DVS} - \text{DSLAI}))$$

should be supplied (Fig. 3.11, Section 3.2.9). The SLAMAX is the maximum SLA value measured in the experimental set in the early growing season. The use of the smooth function prevents irregularities in the course of simulated LAI at transition points in the look-up table. The SLA is calculated from experimental data by dividing the measured leaf area index by the green leaf weight. The program PARAM (Section 8.2) calculates SLA values from experimental data.

The table SSGATB gives the specific green stem area (SSGA; $\text{m}^2 \text{ stem kg}^{-1} \text{ stem}$) as a function of development stage (DVS) the same way as SLATB does for specific leaf area.

* 3. Photosynthesis parameters

FRPAR = 0.5 ! Fraction of sunlight energy that is
! photosynthetically active (-)

SCP = 0.2 ! Scattering coefficient of leaves for PAR (-)

CO2REF = 340. ! Reference level of atmospheric CO2 (ppm)

CO2 = 340. ! Ambient CO2 concentration (ppm)

* Table of light extinction coefficient for leaves (-; Y-value) as a
* function of development stage (-; X value):

KDFTB = 0.00, 0.4,
0.65, 0.4,
1.00, 0.6,

2.50, 0.6

* Table of extinction coefficient of N profile in the canopy (-; Y-value)
* as a function of development stage (-; X value):

KNFTB = 0.0, 0.4,
2.5, 0.4

* Table of light-use efficiency (-; Y-value) as a function of
* temperature (oC; X value):

EFFTB = 10.,0.54,
40.,0.36

* Table of effect of temperature on AMAX (-; Y-value) as a function of
* temperature (oC; X value):

REDFTT = -10., 0.,
10., 0.,
20., 1.,
37., 1.,
43., 0.

* Table of N fraction in leaves on leaf area basis (g N m⁻² leaf;
* Y-value) as a function of development stage (-; X value):

NFLVTB = 0.00, 0.54,
0.16, 0.54,
0.33, 1.53,
0.65, 1.22,
0.79, 1.56,
1.00, 1.29,
1.46, 1.37,
2.02, 0.83,
2.50, 0.83

The fraction of total incident sunlight that is photosynthetically active (FPAR; -) is about 0.5 (Goudriaan and van Laar 1994). The scattering coefficient (SCP; -) has the standard value of 0.2, indicating that 20% of the radiation is reflected or transmitted by a single leaf (Goudriaan and van Laar 1994). This coefficient is used to calculate the extinction coefficients for the different types of radiation. The standard ambient CO₂ concentration (CO2REF; ppm) has been set at 340 ppm. To evaluate climate change scenarios, the actual CO₂ concentration (CO2; ppm) has to be supplied as CO₂ (which, by default, has been set at 340 ppm as well).

Values for the light extinction coefficient (KDF; -) range from 0.4 to 0.7 for monocotyledons (erectophile) and from 0.65 to 1.0 for dicotyledons (Monteith 1969). For rice, we made the extinction coefficient a function of phenological development: a value of 0.4 is used until the canopy closes and 0.6 is used for a closed canopy. This accounts for the clustering of leaves by planting on hills and the very erect stature of the leaves at early stages. In the table KDFTB, the first column gives the development stage (DVS) and the second the

corresponding extinction coefficient (KDF). The extinction coefficient has to be measured under an overcast sky. Direct radiation has to be avoided as the solar elevation determines the extinction coefficient for direct radiation (Eqn. 3.12) (in the morning, all direct radiation will be absorbed and scattered in the top layer because of the path length, whereas, at noon, direct radiation will penetrate further in the canopy). If measurements have to be taken with a clear sky, a board can be used to shade the light measurement instrument. Light extinction can be measured by comparing radiation intensity above and below the canopy using a lightbar (generally a 1-m-long tube with radiation sensors built in). From the LAI and the measured light extinction, the extinction coefficient can be calculated using Eqn. 3.9. When solar short-wave radiation (wavelength 300–3,000 nm) is measured, the extinction coefficient for photosynthetically active radiation (wavelength 400–700 nm) will be about two-thirds of the value measured for solar short-wave radiation because absorption of near-infrared radiation by the canopy is less efficient. An important factor that may confound interpretation of measurements is the light absorption by organs other than leaves. In the model ORYZA2000, this is accounted for by specifically calculating light absorption by leaves, stems, and storage organs. However, when measuring light extinction in the field, the area of organs other than leaves should also be accounted for in the calculation of the extinction coefficient; the other option is to remove the flowers and then the leaves after the first light measurements and repeat the light measurements (for theoretical considerations on the extinction coefficient, see “Absorbed radiation” in Section 3.2.2).

In ORYZA2000, canopy CO₂ assimilation is calculated on the basis of the CO₂ assimilation-light response of individual leaves. This response follows a saturation type of function, characterized by the initial slope, called the initial light-use efficiency (EFF; kg CO₂ ha⁻¹ leaf h⁻¹/(J m⁻² leaf s⁻¹)) (Section 3.2.2, “Instantaneous canopy CO₂ assimilation”; Eqn. 3.6). The value of EFF is a linear function of temperature: 0.54 at 10 °C and 0.36 at 40 °C kg CO₂ ha⁻¹ leaf h⁻¹/(J m⁻² leaf s⁻¹) (Ehleringer and Pearcy 1983). In the table EFFTB, the first column gives the values of average temperature and the second column gives the corresponding value of EFF.

The N profile in the canopy follows an exponential “dilution” pattern. In the model, this is accounted for by using an extinction coefficient KNF (-), which is specified as a function of development stage. The value of 0.4 was based on preliminary measurements in field experiments at IRRI during grain filling. More data are required to derive this relationship for a wide range of conditions. In the table KNFTB, the first column gives development stage values and the second column gives the corresponding values of KNF.

The table REDFTT quantifies the effect of daytime average temperature on the maximum rate of leaf photosynthesis (after Penning de Vries et al 1989): the first column gives values of average temperature and the second column

gives the multiplication effect REDFT (-) (Section 3.2.2, "Maximum leaf photosynthesis rate").

The average leaf N content on an area basis (NFLV; g N m⁻² leaf) of the canopy is specified as a function of DVS in the table NFLVTB: the first column gives the development stage values and the second column gives the corresponding leaf N content (NFLV). The values used in the model were derived from the 1992 dry-season experiment with IR72 at high N levels and can be used for estimates of yield potential.

* 4. Maintenance parameters

* Maintenance respiration coefficient (kg CH₂O kg⁻¹ DM d⁻¹) of
MAINLV = 0.02 ! Leaves
MAINST = 0.015 ! Stems
MAINSO = 0.003 ! Storage organs (panicles)
MAINRT = 0.01 ! Roots

TREF = 25. ! Reference temperature (oC)
Q10 = 2. ! Factor accounting for the increase in maintenance
! respiration with a 10 oC rise in temperature (-)

The maintenance requirements are more or less proportional to the biomass to be maintained. For rice leaves, stems, and roots, values of 0.02, 0.015, and 0.010 kg CH₂O kg⁻¹ dry matter d⁻¹, respectively, are used (Penning de Vries et al 1989). For storage organs, the value can be approximated by calculating maintenance respiration for the active tissue only, representing the envelope of the stored material such as the hull in rice, as the biomass stored is biochemically stable and does not require maintenance. For rice we assumed that a percentage of the biomass is inactive, which resulted in a low coefficient (0.003). Maintenance requirements decrease with the metabolic activity of the plant. In the model, this is accounted for by assuming that plant maintenance respiration is proportional to the fraction of the accumulated leaf weight that is still green (Spitters et al 1989).

* 5. Growth respiration parameters

* Carbohydrate requirement for dry matter production
* (kg CH₂O kg⁻¹ DM leaf) of
CRGLV = 1.326 ! Leaves
CRGST = 1.326 ! Stems
CRGSO = 1.462 ! Storage organs (panicles)
CRGRT = 1.326 ! Roots
CRGSTR = 1.11 ! Stem reserves

LRSTR = 0.947 ! Fraction of allocated stem reserves that is
! available for growth (-)

The primary assimilates in excess of the maintenance cost are converted into structural plant material. The amount of structural dry matter produced per

unit of available carbohydrates depends on the chemical composition of the dry matter formed. Typical values of the glucose requirements (CR...) for various groups of compounds were derived on the basis of their chemical composition by Penning de Vries and van Laar (1982, modified by Penning de Vries et al 1989).

* 6. Growth parameters

```
FSSTR = 0.20      ! Fraction of carbohydrates allocated to the stems
                    ! that is stored as reserves (-)
TCLSTR = 10.      ! Time coefficient for loss of stem reserves (1 d-1)
SPGF = 64900.    ! Spikelet growth factor (number kg-1)
WGRMX = 0.0000249 ! Maximum individual grain weight (kg grain-1)
```

* Partitioning tables

* Table of fraction of total dry matter partitioned to the shoot
* (-; Y-value) as a function of development stage (-; X value):

```
FSHTB = 0.00, 0.50,
        0.43, 0.75,
        1.00, 1.00,
        2.50, 1.00
```

* Table of fraction of shoot dry matter partitioned to the leaves
* (-; Y-value) as a function of development stage (-; X value):

```
FLVTB = 0.000, 0.60,
        0.500, 0.60,
        0.750, 0.30,
        1.000, 0.00,
        1.200, 0.00,
        2.5 , 0.
```

* Table of fraction of shoot dry matter partitioned to the stems
* (-; Y-value) as a function of development stage (-; X value):

```
FSTTB = 0.000, 0.40,
        0.500, 0.40,
        0.750, 0.70,
        1.000, 0.40,
        1.200, 0.00,
        2.5 , 0.
```

* Table of fraction of shoot dry matter partitioned to the panicles
* (-; Y-value) as a function of development stage (-; X value):

```
FSOTB = 0.000, 0.000,
        0.500, 0.000,
        0.750, 0.000,
        1.000, 0.600,
        1.200, 1.000,
        2.5 , 1.
```

* Table of leaf death coefficient (d-1; Y-value) as a function of
 * development stage (-; X value):

DRLVT = 0.00, 0.000,
 0.60, 0.000,
 1.00, 0.015,
 1.60, 0.025,
 2.10, 0.050,
 2.50, 0.050

In the model, the total daily dry matter increment is partitioned to the various plant organ groups according to fractions that are a function of the development stage. These fractions are derived by analyzing the fractions of new dry matter production allocated to the plant organs between two subsequent harvests. An important detail is that for stems and leaves the decrease in dry weight (after flowering) cannot be accounted for; this maximum value is used for partitioning calculations when dead leaves are not measured. The relationships used in the example data file are given in Figure 7.1. The dry matter distribution patterns in the various experiments corresponded well with each other, indicating small seasonal and varietal effects.

The following procedure can be followed to calculate the partitioning tables (FLVTB, FSTTB, FSOTB):

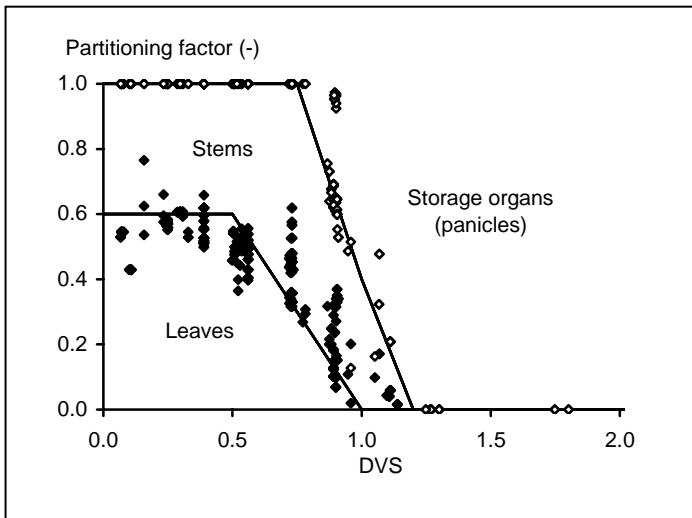

Fig. 7.1. Dynamic distribution pattern of aboveground dry matter over leaves, stems, and panicles for IR72. The data are from various experiments executed at IRRRI from 1991 to 1993, with various N treatments (N rates ranging from 0 to 400 kg ha⁻¹ and splits from 1 to 7): closed symbols represent the fraction of assimilates partitioned to leaves; open symbols represent the fraction of assimilates partitioned to leaves and stems combined. The drawn lines are the fitted curves used for IR72 in ORYZA2000.

1. Calculate the DVS values for the sampling dates of biomass components.
2. Make a table including sampling date, development stage (DVS), weight of leaves (WLV), stems (WST), and panicles (WPA), and totals and difference in weight between two harvests (dGrowth). It is important to use the maximum weight after flowering (*) when the weight decreases because the model accounts for such decreases in a different way.

Sampling date (d)	DVS	WLV (kg ha ⁻¹)	WST (kg ha ⁻¹)	WPA (kg ha ⁻¹)	Total (kg ha ⁻¹)	dGrowth (kg ha ⁻¹)
100	0.8	2000	4000	0	6000	
120	1.0	2500	6000	1000	9500	3500
140	1.2	2500*	6000*	3000	11500	2000
160	1.4	2500*	6000*	5000	13500	2000

In this example, after flowering (DVS = 1) there is no increase in leaves and stem. Note: the program PARAM performs these calculations automatically (Section 8.2).

3. Calculate the mean DVS for the periods between two harvests and divide the increase in weight per organ by the total increase in weight for the different periods.

DVS	FLV	FST	FSO
0.9	500/3500 = 0.14	2000/3500 = 0.57	1000/3500 = 0.29
1.1	0/2000 = 0.	0/2000 = 0.	2000/2000 = 1.
1.3	0/2000 = 0.	0/2000 = 0.	2000/2000 = 1.

4. Plot the data in a graph such as Figure 7.1 and draw the lines that indicate the partitioning. Write these fractions on the corners of the lines in the partitioning tables: the first column gives the DVS values and the second column gives the corresponding partitioning value. Note that in Figure 7.1 the fitted line for assimilate partitioning to leaves is drawn on the left-hand side of the measured/calculated data rather than through the center of the data. This is because the partitioning calculated from measured weights of leaves following the procedure explained above is biased around the period of flowering. It is known that no more biomass goes to the leaves after flowering. However, many biomass measurements are made (just) after flowering. When these are used in the computation of the partitioning factor for leaves, the mean DSV over the calculation interval is biased toward values that are too high. This bias can be taken into account by fitting the line for partitioning to leaves to the left-hand side of the calculated data around flowering.

The relative death rate of the leaves (RDR (given as a function of DVS in the table DRLVT); d^{-1}) was calculated in a simplified way from experimental data on leaf weight. For the time interval between two samplings, the relative

death rate can be calculated as follows, starting at the time when the leaf dry matter is highest:

$$\text{RDR} = (\ln W_t - \ln W_{t+dt})/dt \quad (7.1)$$

where W_t is the biomass of leaves at time t and t is expressed in days. To relate the relative death rate to the development stage, the calculated relative death rate is assumed to be the rate at the average development stage between the samplings. The program PARAM calculates RDR from experimental data (Section 8.2).

The fraction of carbohydrates allocated to the stems, which is stored as reserves (FSTR; -), can be calculated by maximum stem weight (at flowering) minus stem weight at final harvest, divided by maximum stem weight. For example, if stem weight at flowering is $5,000 \text{ kg ha}^{-1}$ and stem weight at harvest is $4,000 \text{ kg ha}^{-1}$, then FSTR is $(5,000 - 4,000)/5,000 = 0.20$. The program PARAM calculates FSTR from experimental data (Section 8.2). This is a relatively rough method, but it gives a first estimate of the net allocation of the stem reserves. Direct measurements of stem reserves and their allocation has not yet led to quantitative insights into this process. The time coefficient for stem reserves allocation (TCLSTR; d) was estimated at 10 days.

The spikelet growth formation factor (SPGF; number kg^{-1}) was derived as the slope of the relationship between spikelet number m^{-2} and growth of the crop between panicle initiation and flowering (Fig. 3.8, Section 3.2.8).

WGRMX is the maximum individual grain weight (kg grain^{-1}).

* 7. Carbon balance parameters

* Mass fraction of carbon (kg C kg^{-1} DM) in the

FCLV = 0.419 ! Leaves
 FCST = 0.431 ! Stems
 FCSO = 0.487 ! Storage organs (panicles)
 FCRT = 0.431 ! Roots
 FCSTR = 0.444 ! Stem reserves

The parameters specifying the mass fraction of carbon in various crop organs (used in the carbon balance check of ORYZA2000) are taken from Penning de Vries et al (1989).

* 8. Root parameters

GZRT = 0.01 ! Growth rate of roots (m d^{-1})
 ZRTMCW = 0.25 ! Maximum depth of roots if no drought stress (m)
 ZRTMCD = 0.40 ! Maximum depth of roots if drought (m)

All root growth parameters were taken from Wopereis (1993) and Wopereis et al (1996a). Maximum root depth (m) with or without drought stress can simply be measured by making root profiles in the field or by taking soil core samples. The growth rate of roots (GZRT; m d^{-1}) can be calculated from subsequent root depth samplings in time.

* 9. Drought stress parameters

* Upper and lower limits for drought stress effects

ULLS = 74.13 ! Upper limit leaf rolling (kPa)
 LLLS = 794.33 ! Lower limit leaf rolling (kPa)
 ULDL = 630.95 ! Upper limit death of leaves (kPa)
 LLDL = 1584.89 ! Lower limit death of leaves (kPa)
 ULLE = 1.45 ! Upper limit leaf expansion (kPa)
 LLE = 1404. ! Lower limit leaf expansion (kPa)
 ULRT = 74.13 ! Upper limit relative transpiration reduction (kPa)
 LLRT = 1584.89 ! Lower limit relative transpiration reduction (kPa)

* Switch to use ULTR and LLTR as given above or function built in ORYZA
 * for the reduction in relative transpiration:

*SWIRTR = 'DATA' ! Use data
 SWIRTR = 'FUNCTION' ! Use function

The upper and lower limits for drought stress effects were all derived from pot experiments on IR20 and IR72 by Wopereis et al (1996a,b). Tuong et al (unpublished data) derived different values for ULLE and LLE in their pot experiments on IR72: ULLE = 1.45 and LLE = 1404. If SWIRTR = 'DATA', the model uses the ULRT and LLRT limits for linear interpolation of the reduction in transpiration. If SWIRTR = 'FUNCTION', the model uses the built-in function $T_a/T_p = 2/(1 + \exp(k \times h))$ (-), with $k = 0.00085$, to calculate the relative transpiration ratio as a function of soil-water tension (Section 4.2.4).

* 10. Nitrogen parameters

NMAXUP = 8. ! Maximum daily N uptake (kg N ha⁻¹ d⁻¹)
 RFNLV = 0.004 ! Residual N fraction of leaves (kg N kg⁻¹ leaves)
 FNTRT = 0.15 ! Fraction N translocation from roots, as (additional)
 ! fraction of total N translocation from stems
 ! and leaves (-)
 RFNST = 0.0015 ! Residual N fraction of stems (kg N kg⁻¹ stems)
 TCNTRF = 10. ! Time coefficient for N translocation to grains (d)
 NFLVI = 0.5 ! Initial leaf N fraction (on area basis: g N m⁻² leaf)
 FNLVI = 0.025 ! Initial leaf N fraction
 ! (on weight basis: kg N kg⁻¹ leaf)

NMAXSO = 0.0175 ! Maximum N concentration in storage organs (kg N kg⁻¹)

* Table of minimum N concentration in storage organs (kg N kg⁻¹ DM;
 * Y value) as a function of the amount of N in the crop till flowering
 * (kg N ha⁻¹; X value):

NMINSOT = 0., .006,
 50., .0008,
 150., .0125,
 250., .015,
 400., .017,
 1000., .017

* Table of maximum leaf N fraction on weight basis (kg N kg⁻¹ leaves;

* Y value) as a function of development stage (-; X value):

NMAXLT = 0.0, .053,
0.4, .053,
0.75, .040,
1.0, .028,
2.0, .022,
2.5, .015

* Table of minimum leaf N fraction on weight basis (kg N kg⁻¹ leaves;

* Y value) as a function of development stage (-; X value):

NMINLT = 0.0, 0.025,
1.0, 0.012,
2.1, 0.007,
2.5, 0.007

* Table of effect of N stress on leaf death rate (-; Y value)

* as a function of N stress level (-; X value):

NSLLVT = 0., 1.0,
1.1, 1.0,
1.5, 1.4,
2.0, 1.5,
2.5, 1.5

The nitrogen parameter values were derived from a large number of measurements in experiments under different nitrogen regimes at IRRI (Drenth et al 1994; unpublished data).

Rice plants are physiologically limited in the daily amount of N they can take up (NMAXUP; kg N ha⁻¹ d⁻¹). Peng and Cassman (1998) observed nitrogen uptake in tropical rice at IRRI on a two-day basis and calculated maximum uptake rates as high as 9–12 kg N ha⁻¹ d⁻¹. We set the average maximum nitrogen uptake rate by the crop at 8 kg ha⁻¹ d⁻¹.

The residual fraction of nitrogen in leaves (FRNLV; kg N kg⁻¹ leaves) and stems (RFNST; kg N kg⁻¹ stems) was estimated from N content measured at maturity or harvest. It was estimated that the roots contribute a fraction (FNTRT; 0.15) of the amount of nitrogen translocated from leaves and stems combined (P.K. Aggarwal, personal communication). The time coefficient for nitrogen translocation to the grains (TCNTRF; d) was estimated at 10 days.

The initial fractions of nitrogen in the leaves—NFLVI (g N m⁻² leaf) and FNLVI (kg N kg⁻¹ leaf)—were estimated as 0.5 and 0.025, respectively.

The maximum content of nitrogen in the storage organs (NMAXSO; kg N kg⁻¹ dry matter) is a single value, independent of development stage, and Drenth et al (1994) calculated a value of 0.0175 kg N kg⁻¹ dry matter (see also Fig. 5.3, Section 5.1.1). The minimum content of nitrogen in the storage organs (NMINSO; kg N kg⁻¹ dry matter) is determined by the amount of nitrogen in the crop at the moment of flowering (ANCRF; kg ha⁻¹). Figure 5.3 (Section

5.1.1) shows the relationship between NMINSO at harvest and ANCRF. The drawn line is the empirical relationship between NMINSO and ANCRF as tabulated in NMINSOT: the first column gives the values of ANCRF and the second the corresponding values of NMINSO.

The maximum and the minimum nitrogen content in the leaves change with the development stage (Fig. 5.1, Section 5.1.1). The maximum and minimum nitrogen content of leaves are supplied as the tables NMAXLT and NMINLT, respectively: the first column gives the DVS values and the second the corresponding N content values.

The loss rate of leaves is affected by the nitrogen status of the crop. The factor NSLLV (-) expresses the increase in leaf death as a function of nitrogen deficiency in the crop. In ORYZA2000, this nitrogen deficiency is expressed by a factor called NSTRES (-), calculated as the ratio of maximum (or potential) amount of N in the crop over the actual amount of N in the crop (Section 5.1.5). Aggarwal (personal communication) found that the leaf death rate was unaffected when NSTRES was 1.1 and increased by 50% when NSTRES increased to or surpassed 2. In the table NSLLVT, the first column gives the values of NSTRES and the second the corresponding multiplication effects on leaf death rate NSLLV.

7.4 The soil data file

```
*****
* Soil data file for PADDY soil-water balance model. *
* File name      : SIRRI.DAT *
* Soil           : IIRRI lowland farm, Los Banos, Philippines *
* Experiment     : Parameter values derived by Wopereis, as reported in *
* Wopereis MCS, Bouman BAM, Tuong TP, Berge HFM ten, Kropff MJ. 1996, *
* ORYZA_W: Rice growth model for irrigated and rainfed environments. *
* SARP Research Proceedings. IRRI/AB-DLO, Wageningen, The Netherlands*
* Data on page 151. *
*****
```

The soil data file contains all data to run the soil-water balance module PADDY (Section 6.2). This data file should be present when ORYZA2000 is run with a water balance (PRODENV = 'WATER BALANCE' in the experimental data file).

```
* Give code name of soil data file to match the water balance PADDY
SCODE = 'PADDY'
```

In principle, different soil-water balance modules can be used in ORYZA2000; therefore, first a check is made whether the correct soil data file is supplied. For the PADDY model, the check variable SCODE should be set at "PADDY".

```

*-----*
* 1. Various soil and management parameters
*-----*
WLOMX = 250. ! Bund height (mm)
NL     = 9    ! Number of soil layers (maximum is 10) (-)
TKL    = 3*0.05, 3*0.05, 0.10, 0.20, 0.20 ! Thickness of each soil layer (m)
ZRTMS  = 1.0  ! Maximum rooting depth in the soil (m)

```

In the first section, some general soil and management characteristics need to be supplied. The bund height WLOMX (mm) is a management parameter and determines the maximum depth of ponded water. The parameter NL (-) sets the number of soil layers with distinct hydraulic properties. For each soil layer, the PADDY model simulates the soil-water balance in time based on supplied hydraulic properties. The maximum number of soil layers is set at 10. For each soil layer, its thickness needs to be supplied in the table TKL. Data can be entered as a list of values for each layer or using the multiplication sign to indicate the same values for subsequent layers. For example, the definition

```
TKL = 3*0.05, 3*0.07, 0.10, 0.20, 0.20
```

is the same as

```
TKL = 0.05, 0.05, 0.05, 0.07, 0.07, 0.07, 0.10, 0.20, 0.20.
```

The parameter ZRTMS (m) gives the maximum rooting depth possible in the particular soil under consideration. This depth is determined strictly by the soil and is not crop-type dependent. For instance, if the soil consists of a well-developed profile of 1.5 m depth on top of hard rock, then ZRTMSD = 1.5 (even if rice roots would grow only 0.4 m deep).

```

*-----*
* 2. Puddling switch: 0 = PUDDLED or 1 = NONPUDDLED
*-----*
*SWITPD = 0 ! Nonpuddled
SWITPD = 1 ! Puddled

* If PUDDLED, supply parameters for puddled soil
NLPUD = 3 ! Number of puddled soil layers, including the plow sole (-)
        ! (NLPUD cannot exceed the total number of soil layers NL)

* Saturated volumetric water content of ripened (previously puddled)
* soil (m3 m-3), for each soil layer:
WCSTRP = 3*0.52, 3*0.55, 2*0.61, 0.64

* Soil-water tension of puddled soil layer at which cracks
* break through the plow sole (pF):
PFCR = 6.0

```

The puddling switch SWITPD determines whether the soil is puddled (PUDDLED) or not (NONPUDDLED). If the soil is puddled, some specific parameters need to be supplied. The number of puddled soil layers is set with NLPUD. Note that the compacted plow layer is considered the bottom layer of the puddled zone. This number of puddled layers forms part of the already defined total number of soil layers NL. For each soil layer (defined by the number of NL), the saturated volumetric water content after ripening should be provided as a list of values per soil layer, WCSTRP ($\text{m}^3 \text{m}^{-3}$). Note that, for unpuddled soil layers, this value should be the same as the value supplied for saturated volumetric water WCST (see below). The parameter PFCR (pF) defines the soil-water tension at which cracks developing during drying penetrate the plow layer. If the soil is noncracking, a value higher than 7 (air dryness) should be given here. The value for PFCR has to be determined from field observations (water content sampling when cracks penetrate the plow sole).

```
*-----*
* 3. Groundwater switch: 0 = DEEP (i.e., not in profile), 1 = DATA
*   (supplied), 2 = CALCULATE
*-----*
*SWITGW = 0 ! Deep groundwater
*SWITGW = 2 ! Calculate groundwater
SWITGW = 1 ! Groundwater data

* If DATA, supply table of groundwater table depth (cm; Y-value)
* as a function of calendar day (d; X-value):
ZWTB =  1.,150.,
       366.,150.

* If CALCULATE, supply the following parameters:
ZWTBI = 100. ! Initial groundwater table depth (cm)
MINGW = 100. ! Minimum groundwater table depth (cm)
MAXGW = 100. ! Maximum groundwater table depth (cm)
ZWA   = 1.0 ! Receding rate of groundwater with no recharge (cm d-1)
ZWB   = 0.5 ! Sensitivity factor of groundwater recharge (-)
```

The groundwater switch SWITGW indicates whether groundwater data are provided by the user or are to be simulated by PADDY. If SWITGW = 0, the groundwater table is assumed to be far beyond the root zone so that no capillary rise can contribute to crop water use. If SWITGW = 1, the groundwater is shallow (within reach by roots through capillary rise) and observed values for the experiment under simulation should be supplied as a function (table) of day number (ZWTB). In table ZWTB, the first column contains the day numbers (d) and the second the corresponding groundwater depths (cm). The model PADDY will interpolate daily values between the “groundwater table and day number” data pairs. If SWITGW = 2, PADDY will calculate

daily water tables depths. In this case, initial conditions and some model parameters need to be supplied. The parameter ZWTBI defines the initial groundwater depth at the start of the simulation, and the parameters MINGW (cm) and MAXGW (cm) the minimum and maximum groundwater depths, respectively. The parameter ZWA (cm d^{-1}) defines the daily rate at which groundwater recedes when there is no recharge from the top (by rainfall, irrigation, or percolation). This parameter can be obtained from daily measurements of groundwater table depths. The parameter ZWB is a sensitivity parameter for recharge that is basically a calibration factor to match simulated with observed changes in groundwater table depth.

```

*-----*
* 4. Percolation switch
*   Value for SWITVP can only be 1 (CALCULATE) for puddled soil
*-----*
SWITVP = -1 ! Fixed percolation rate
*SWITVP = 0 ! Percolation as a function of groundwater depth
*SWITVP = 1 ! Calculate percolation

* If SWITVP = -1, supply fixed percolation rate (mm d-1):
FIXPERC = 3.0

* If SWITVP = 0, supply table of percolation rate (mm d-1; Y-value)
* as a function of water table depth (cm; X-value):
*PERTB = 0., 3.,
*         200., 3.

*-----*
* 5. Conductivity switch: 0 = NO DATA, 1 = VAN GENUCHTEN or
*                          2 = POWER function used
*-----*
*SWITKH = 0 ! No data
*SWITKH = 2 ! Power
SWITKH = 1 ! van Genuchten

```

The percolation switch SWITVP defines the level of detail in the calculation of seepage and percolation rates by PADDY. When SWITVP = -1, a constant water loss rate FIXPERC (mm d^{-1}) is to be supplied that combines seepage and percolation (SP) flows. This simplification of the water-balance processes is allowed in most lowland rice soils except for poorly puddled topsoils overlying relatively permeable subsoils, that is, in soils where percolation rates are relatively high (Bouman et al 1994). When SWITVP = 0, the combined SP rate should be supplied as a function of groundwater table depth PERTB. In this table, the first column gives the groundwater depths (cm) and the second the corresponding SP rate (mm d^{-1}). The model PADDY will interpolate daily values between the “water table depth and SP rate” data pairs. Field-average SP rates can be determined easily in the field from daily sloping gauge or staff

gauge readings (corrected for rainfall and evapotranspiration). Using field-average SP rates, problems with spatial variation in location-specific S and P in the field (such as measured using double-ring infiltrometers) are overcome. Percolation measured near a bund is often much higher than percolation measured in the middle of the field, as a result of poor puddling. Moreover, the SP rate measured with sloping gauges is a net value integrating water losses through vertical and lateral percolation (under bund flow) and lateral seepage to neighboring fields and water gains through capillary rise and lateral inflow (seepage) from neighboring fields.

When SWITVP = 1, seepage is not being considered and percolation rates are dynamically calculated by PADDY from hydraulic conductivity characteristics. Such characteristics thus need to be specified in a parameterized format. The conductivity switch SWITKH determines whether no hydraulic conductivity characteristics are available (SWITKH = 0), are given as parameters of the van Genuchten function (SWITKH = 1), or are given as parameters of the power function (SWITKH = 2). When no data are available (SWITKH = 0), PADDY returns an error message that percolation rates cannot be simulated when there are no hydraulic conductivity characteristics.

```
*-----*
* 6. Water retention switch: 0 = DATA; 1 = VAN GENUCHTEN. When DATA,
*   data have to be supplied for saturation, field capacity,
*   wilting point, and at air dryness
*-----*
*SWITPF = 0 ! Data
SWITPF  = 1 ! van Genuchten
```

Water retention characteristics are the minimum hydraulic characteristics that are required by PADDY. The water retention switch SWITPF determines whether water retention characteristics are given as water content values at specific water tensions (saturation, field capacity, wilting point, and at air dryness) (SWITPF = 0) or as parameter values of the van Genuchten function (SWITPF = 1) (see below).

```
*-----*
* 7. Soil hydrological properties. Required type of data input
*   according to setting of conductivity and water retention switch
*-----*
* Saturated hydraulic conductivity, for each soil layer
* (cm d-1) (always required!):
KST = 2*127.0, 3.0, 3*35.0, 2*103.0, 42.0

* Saturated volumetric water content, for each soil layer
* (m3 m-3)(always required!):
WCST = 3*0.52, 3*0.55, 2*0.61, 0.64
```

```

* Van Genuchten parameters, for each soil layer
* (needed if SWITKH = 1 and/or SWITPF = 1):
VGA = 3*0.127, 3*0.047, 2*0.078, 0.032 ! a parameter (cm-1)
VGL = 3*-6.2, 3*-0.6, 2*-4.9, -11.1 ! l parameter (-)
VGN = 3*1.119, 3*1.095, 2*1.076, 1.073 ! n parameter (-)
VGR = 9*0.01 ! residual water content (-)

* Power function parameters, for each soil layer (-)
* (needed if SWITKH = 2):
*PN = 3*-2.5, 3*-2.5, 2*-2.5, -2.5

* Volumetric water content at field capacity, for each soil layer
* (m3 m-3)(needed if SWITPF = 0):
*WCFC = 3*0.48, 3*0.47, 2*0.52, 0.58

* Volumetric water content at wilting point, for each soil layer
* (m3 m-3) (needed if SWITPF = 0):
*WCWP = 9*0.21

* Volumetric water content at air dryness, for each soil layer
* (m3 m-3) (needed if SWITPF = 0):
*WCAD = 9*0.01

```

The saturated soil conductivity (KSAT; cm d^{-1}) and saturated volumetric water content (WCST; $\text{m}^3 \text{m}^{-3}$) should always be given, for each soil layer, irrespective of the values of the switches SWITKH and SWITPF. If SWITKH = 1 and/or SWITPF = 1 (see above), the van Genuchten parameters should be given for each soil layer. These are the alpha (VGA; cm^{-1}), lambda (VGL; -), and n (VGN; -) parameters, and the van Genuchten residual water content (VGR; -). The van Genuchten equation also requires the saturated hydraulic conductivity already given above (KSAT).

If SWITKH = 2, the power function parameter n (PN; -) needs to be specified to characterize the hydraulic conductivity characteristics. Both the power function and the van Genuchten equation are explained in detail in Section 6.2.2 (“Dynamic calculation of percolation rate”). Programs for parameterization of soil hydraulic properties using van Genuchten equations can be obtained via van Genuchten et al (1991) and Wopereis et al (1994a).

When SWITPF = 0, water retention characteristics should be given, again for each soil layer, as water content values (all in $\text{m}^3 \text{m}^{-3}$) at saturation (WCST), at field capacity (WCFC), at wilting point (WCWP), and at air dryness (WCAD). Field capacity is defined as a soil-water tension of pF 2 (equals 10 kPa), wilting point of pF 4.2 (equals 1,600 kPa), and air dryness of pF 7 (10^6 kPa).

Hydraulic conductivity parameters have to be determined from *in situ* measurements on small samples of a paddy field and/or from laboratory measurements on collected core samples. Spatial variation in soil properties, however, may render measured values not truly representative for the whole

field. Another approach is to derive the required parameter values by inverse calibration of PADDY on field-observed components of the soil-water balance (Wopereis et al 1993a). In this case, observed water losses from a whole field may include seepage losses (besides percolation losses) and the calibrated values of the hydraulic functions then reflect both seepage and percolation rates (although theoretically, they apply to vertical water movement through the soil profile only; Wopereis et al 1994b). Methods to measure soil hydraulic properties from rice soils were described in detail by Wopereis et al (1994a).

```

*-----*
* 8. Initialization conditions and reinitialization
*-----*
WL0I = 10.    ! Initial ponded water depth at start of simulation (mm)

* Initial volumetric water content at the start of simulation,
* for each soil layer (m3 m-3):
WCLI = 3*0.52, 3*0.47, 2*0.52, 0.58

* Initial ponded water depth and water contents can be reset:
* Ponded water depth: at minimum of WL0I and WL0MX
* Water contents in all soil layers: at saturation value
* For direct-seeded rice, this happens at sowing, for transplanted
* rice, this happens at transplanting
* Reinitialize switch RIWCLI is YES or NO
*RIWCLI = 'NO'
RIWCLI = 'YES'

```

The initial depth of ponded water (WL0I; mm) and the initial volumetric water content of each soil layer (WCLI; m³ m⁻³) at the start of the simulation need to be set. There is an option in PADDY to reset these values at the time of crop establishment. This option is defined by the reinitialization switch RIWCLI: the value 'YES' means resetting and the value 'NO' means no resetting. When RIWCLI = 'YES', PADDY will reset the ponded water depth to the initial ponded water depth (WCLI) and the soil water content of each soil layer to its saturated value (WCST).

```

*-----*
* 9. Observations/measurements
*   Switches to force observed water content in water balance
*-----*
* WCL1_OBS, WCL2_OBS, ...WCL10_OBS: Observed soil water content
* in layer 1, 2, ..., 10. Format: year, day number, water content
* Not obligatory to give data

```

The last section of the soil data file is completely optional and contains field measurements on volumetric water content and soil-water tension. These measurements are given in tables in a fixed form: the first column gives the

year of observation, the second the day number of observation, and the third the observed value of the variable. The name of the variable is the same as the name used in the PADDY model with the suffix ‘_OBS’. Since the soil water contents and tensions are so-called arrays, values need to be specified for each soil layer separately, for example, WCL1_OBS ($\text{m}^3 \text{m}^{-3}$) for soil water content in layer 1, WCL2_OBS for soil water content in layer 2, etc., and the same for soil-water tension: MSKPA1_OBS (kPa) for soil-water tension in layer 1, MSKPA2_OBS for soil-water tension in layer 2, etc. Some examples of data input are

```
* Layer 1: 0-5 cm
WCL1_OBS =
1996.0, 87.0, 0.344,
1996.0, 95.0, 0.082,
1996.0, 100.0, 0.046,
1996.0, 103.0, 0.248,
.....
1996.0, 141.0, 0.037,
1996.0, 145.0, 0.058,
1996.0, 148.0, 0.041

* at 5 cm depth
MSKPA1_OBS =
1996.0, 93.0, 47.690,
1996.0, 103.0, 79.211,
1996.0, 104.0, 8.683,
.....
1996.0, 121.0, 42.923,
1996.0, 122.0, 38.156,
1996.0, 124.0, 36.476

** Parameter to select forcing of observed water content, yes (2) or
** no (0) during simulation (instead of using simulated values)
WCL1_FRC = 0 ! No forcing
*WCL1_FRC = 2 ! Forcing
```

The observed values of soil water content (WCLX_OBS, where X stands for any soil layer number) can be used optionally as a forcing function. In that case, the simulated values of soil water content are overruled with daily interpolated values of these variables (Section 6.2.3, “Water content”). The choice for using measured data as a forcing function is defined by the parameter WCLX_FRC (where X stands for any soil layer number). If the value of this parameter is 0, no overruling of the simulated values takes place, and, if the value is 2, overruling with interpolated values will take place. When WCLX_FRC is 2, PADDY will use simulated values until the first observation date is reached. On that date, the simulated variable is reset to the observed value. From then on, daily interpolated values will be used until the last

observation. After that, PADDY will again use simulated values until the end of the simulation.

```
* Table for interpolation of water content between soil layers for
* those layers for which no observations were made: first number is
* soil layer, for which interpolation needs to be carried out,
* second is number of underlying soil layer for interpolation,
* third is number of overlying soil layer for interpolation.
* When all three numbers are the same, no interpolation is performed.
WCLINT = 1, 1, 1,
         2, 2, 2,
         3, 2, 4,
         4, 4, 4,
         5, 5, 5,
         6, 5, 7,
         7, 7, 7,
         8, 8, 8,
         9, 9, 9
```

Quite often, measurements of soil water content are made at certain depths only, which do not always correspond with defined soil layers. Simulated soil water content of soil layers for which no measured values are available can again be overruled by interpolation between the measured water content of over- and underlying soil layers. This option is governed by the interpolation variable WCLINT that defines for each soil layer whether interpolation needs to take place, and, if so, between which layers. For each layer, WCLINT requires three numbers: the first one identifies the layer number and the second and third numbers identify the underlying and overlying layers, respectively, to be used in the interpolation (see also “Water content” in Section 6.2.3). If all three numbers are the same (i.e., all referring to the same layer), no interpolation is performed.

In the example above, no interpolation is performed for soil layers 1, 2, 4, 5, and 7 to 9. The water content of layer 3 is obtained by interpolation between the water contents of layers 2 and 4 and the water content of layer 6 is obtained by interpolation between the water contents of layers 5 and 7.

7.5 The weather data file

```
*-----
* File name      : PHIL1.992
* Station name:  IRWE0001   IRRI wetland site, Los Banos
* Author        : Climate Unit, IRRI   -99.: nil value
* Source        : International Rice Research Institute (IRRI)
*
* Comments      : This file is extracted from CLICOM database.
* Longitude:    121 15 E   Latitude: 14 11 N   Altitude: 21.0 m
```

```

*
* Column      Daily value
*   1         Station number
*   2         Year
*   3         Day
*   4         Irradiance           kJ m-2 d-1
*   5         Min temperature      oC
*   6         Max temperature      oC
*   7         Vapor pressure       kPa
*   8         Mean wind speed      m s-1
*   9         Precipitation        mm d-1
*-----
121.25  14.18  21.0  0.00  0.00
  1 1992  1 16379  21.6  29.0  2.38  1.9  0.0
  1 1992  2 15911  22.2  29.2  2.51  2.3  0.0
  1 1992  3 16631  21.5  29.0  2.50  2.5  0.0
  1 1992  4 18251  22.1  29.0  2.52  2.4  0.0
  1 1992  5 11519  21.6  29.0  2.61  1.1  0.9
  1 1992  6 15119  19.9  29.4  2.59  1.4  0.4
  1 1992  7 10475  21.2  28.0  2.72  1.2  2.2
.....
  1 1992 362  9683  22.7  27.0  2.72  1.7  0.8
  1 1992 363  9323  23.5  28.2  2.80  1.2  0.0
  1 1992 364 17531  22.9  29.6  2.67  1.7  0.4
  1 1992 365 21994  20.7  30.0  2.57  2.2  0.0
  1 1992 366 23650  20.5  29.5  2.51  1.7  0.0

```

The identification of a weather data file is explained in Section 7.2 and the retrieval and use of it by ORYZA2000 is explained in Section 2.3. The naming of a weather data file follows a strict convention. Any weather file name consists of three elements: a four-character code indicating the country name, then one or two digits indicating the station number, and then (after a separating period) a three-digit number indicating the year. The year number consists of the last three digits of a full year. For example, 992 indicates 1992, and 000 indicates 2000. An example of a correct weather file name is PHIL1.992: the country code is PHIL (for the Philippines), the station code is 1, and the year 1992. A weather data file that is named PHIL11.001 contains weather data for the year 2001 from station 11 in the Philippines (PHIL).

The weather data files have a fixed format. A complete file contains daily values of radiation ($\text{kJ m}^{-2} \text{d}^{-1}$) or sunshine hours (see below), minimum temperature ($^{\circ}\text{C}$), maximum temperature ($^{\circ}\text{C}$), vapor pressure (kPa), mean wind speed measured at 2 m above the ground surface (m s^{-1}), and precipitation (mm). The meteorological variables are given in columns, with the daily values in rows. Missing values have to be indicated by -99. Before the columns with weather variables are given, however, a first column gives the station number, the second the year, and the third the day number.

On the first line (before the columns are given), the following variables should be supplied: longitude (decimal degree), latitude (decimal degree), and elevation (m) of the weather station, and (optionally) the Ångström A and B parameters. The Ångström parameters are used by the WEATHER system to automatically convert sunshine hours into radiation values (when sunshine hours are given in the data file instead of radiation data) (see also Section 2.3). When radiation values are given in the data file (and no sunshine hours), zero values (0) should be supplied for the Ångström parameters. In the example data file above, the longitude is 121.25 (decimal degree), the latitude 14.18 (decimal degree), the elevation 21.0 m, and the Ångström A and B parameters 0.

The WEATHER system automatically checks the availability of weather data at each time step of the model and stops the simulation with an error message when requested data are not available (see also Section 2.3).

7.6 The rerun file

The FSE system in which ORYZA2000 is programmed allows for automatic “reruns” of the model. In a rerun, ORYZA2000 is executed again with new values of selected parameters. Reruns can be done on all parameter values, initial states, and names occurring in all input data files, and on the names of all input files specified in the control file CONTROL.DAT (except for the name of the rerun file itself and on the start and end run number of the reruns). Arrays can also be redefined in a rerun file. All parameters and data files that are not redefined in the so-called rerun data file retain their original values. The rerun data file is named in the CONTROL.DAT file. If the rerun file is empty, or not present at all, ORYZA2000 will be executed just once with the settings and input data files specified in the CONTROL.DAT file.

More than one rerun can be defined in the rerun file and there is no limit to the number of reruns that can be made. The number of parameters that are redefined is also limitless. Names of variables originating from different data files can be redefined in the same rerun file. However, the order and number of the variables should be the same in each so-called rerun set. A new set starts when the first variable name is repeated. This is shown in the following example:

```
* File name: RERUNS.DAT (example 1)
* rerun set 1
SBDUR = 14.
NH     = 10.
* rerun set 2
SBDUR = 20.
NH     = 15.
```

In this example, two parameters of the experimental data file are changed simultaneously. After running ORYZA2000 with the original parameter values

for SBDUR and NH, two additional reruns are made with the changed parameter values. The total number of runs is thus three.

```
* File name: RERUNS.DAT (example 2)
* rerun set 1
EMD = 50.
CO2 = 380.
* rerun set 2
EMD = 100.
CO2 = 380.
* rerun set 3
EMD = 50.
CO2 = 400.
* rerun set 4
EMD = 100.
CO2 = 400.
```

In the second example, again two variables are changed, but one variable (EMD) comes from the experimental data file and the other (CO₂) from the crop data file. This example also illustrates that each set should contain and define all parameters that make up the set. Thus, although the value of CO₂ does not change from set 1 to set 2, it is defined in both sets. In this example, ORYZA2000 is executed five times (one “original” run, plus four reruns).

```
* File name: RERUNS.DAT (example 3)
FILEIT = 'c:\ORYZA\data\ir72ds92\ir72DS0.T92'
FILEIT = 'c:\ORYZA\data\ir72ds92\ir72DS1.T92'
FILEIT = 'c:\ORYZA\data\ir72ds92\ir72DS2.T92'
```

In the third example, reruns are made on whole input data files. Each of the three experimental data files contains information on a specific treatment of a nitrogen experiment executed in the dry season of 1992 at IRRI. In this case, the rerun file defines the simulation of a whole field experiment with three nitrogen treatments.

There is an option in the file CONTROL.DAT to control the number of reruns made (Section 7.1). The start (strun) and end rerun number (endrun) can be specified. For instance, if strun = 1 and endrun = 2, then only the first and second rerun sets are executed; the “original” run and all rerun sets after the second are not executed. The parameters strun and endrun are optional and can also be removed. In that case, the original and all reruns specified in the rerun file are executed.

7.7 The output files

ORYZA2000 creates five output files. Two of these can be named by the user in the CONTROL.DAT file (Section 7.1), the other three are predetermined.

The model log report is named by the user in the CONTROL.DAT file at the variable FILEOL, for example,

```
FILEOL = 'MODEL.LOG'      ! Log file
```

This file contains any warning or error messages generated during model execution. Messages about replacements of parameter values by the rerun facility can be particularly useful. To make sure that the execution of ORYZA2000 was without errors, this file needs to be inspected.

The main data output file is named by the user in the CONTROL.DAT file at the variable FILEON, for example,

```
FILEON = 'RES.DAT'      ! Output file
```

This file contains all the output of the model written during the simulation using the subroutine OUTDAT of TTUTIL (Section 2.4.2). If reruns are made, the output produced during each rerun appears below each other in the file. The format of this output file depends on the settings of certain parameters in the CONTROL.DAT file (Section 7.1).

The file OP.DAT (fixed name) also contains printed variable values, but only end-of-simulation values (written using the subroutine OPSTOR of the library OP_OBS; see examples at the end of Section 2.2.2). Here, for instance, final yield and total crop duration are printed. Variable values are printed in columns, with each row representing a rerun.

The file RES.BIN (fixed name) is a binary file and contains information that can be read only by the graphics program TTSELECT (Sections 8.1.2 and 8.1.3). TTSELECT can be used to quickly plot and view simulated variables.

The file WEATHER.LOG (fixed name) contains messages generated by the WEATHER system. The variable IFLAG in the CONTROL.DAT file (Section 7.1) determines whether error and warning messages are sent to this log file and/or to the screen. All the comment headers of the weather data files are also written to this log file. If shortly before termination of ORYZA2000 a message is displayed about possible errors and warnings from the WEATHER system, one has to look into this file and interpret the messages. They could be as unimportant as rainfall not being available when it was not used by the model, but they can also be of a much more severe nature.

8 Model installation, running, and calibration

This chapter explains how to install and run the model ORYZA2000 (Sections 8.1.2 and 8.1.3) and how to calibrate it and use the two utility programs DRATES and PARAM (Section 8.2), describes the model's validity domain (Section 8.3), and gives some examples of model applications (Section 8.4). The programs and the example data files are found on the CD-ROM accompanying this book. Additionally, the CD-ROM contains copies of manuals and documentation relating to specific components of ORYZA2000 not described in this book. The contents of the CD-ROM are summarized in Table 8.1 and details are given in Tables 8.2 and 8.3.

To install and run any of these programs, ORYZA2000, DRATES, or PARAM, copy the whole directory ORYZA with all subdirectories and included files to the hard disk of your computer: C:\ORYZA\...\... Since the CD-ROM does not include specialized installation software, indicated files must be copied with a file manager (Windows Explorer, Norton Commander, etc.) to your hard disk. Any "read-only" property of the files must be removed using a file manager. For example, with using the Windows Explorer, highlight the folder ORYZA, then under Edit menu, select Select All, under File menu, select Properties, undo the read-only attribute, and click the OK button.

8.1 Installation and running of ORYZA2000

ORYZA2000 was programmed in Compaq Visual FORTRAN (CVF), version 6.1, on IBM-compatible personal computers. There are two ways to install and run ORYZA2000: (1) under CVF, allowing the user to change the program code and to subsequently compile and link a new version of ORYZA2000 (Section 8.1.2), and (2) as stand-alone executable, which allows the user to run the standard version of the model without making changes to the source code (Section 8.1.3). First, however, the example data files that can be used with ORYZA2000 are described (Section 8.1.1).

8.1.1 Example data sets

Three example data sets for ORYZA2000 are provided in the subdirectory ORYZA\DATA (on CD-ROM and that you copied to your hard disk) (Table 8.2):

- IR72DS92 contains a complete data set of a field experiment using IR72 with three fertilizer nitrogen application rates (treatments), executed at IRRI, Los Baños, Philippines, in the dry season of 1992. More information on this experiment and on the application of ORYZA2000 is given by

Kropff et al (1994a). The headers of the experimental data files give information on the treatments of the experiment.

- JAK-WJ96 contains a complete data set of a field experiment using IR64 under rainfed and irrigated conditions, carried out at Jakenan, Indonesia, in the *walik jerami* season of 1996. More information on this experiment and on the application of ORYZA2000 is given by Boling et al (2000). The headers of the experimental data files give information on the treatments of the experiment.
- IRRI contains a set of data files that run ORYZA2000 in the water- and nitrogen-limited production mode. This is a purely hypothetical example and contains no experimental data.

Table 8.1. Directory structure and contents of CD-ROM.

Directory	Subdirectory1	Subdirectory2	Contents
ORYZA	Calibration	Libraries	Object libraries
		S_Drates	Source code files of DRATES
		S_Param	Source code files of PARAM Executables of DRATES and PARAM with example input and output files
	Data	IR72DS92	Data files of an N-limited experiment at IRRI, dry season 1992
		JAK-WJ96	Data files of a water-limited experiment at Jakenan, Indonesia, rainy season 1996
		IRRI	Data files of a hypothetical water- and N-limited situation
		WEATHER	Weather data files for the three example data sets
	ORYZA2000	Libraries	Object libraries
		S_crop	Source code files of the crop subroutines
		S_main	Source code files of the main subroutines
S_soil		Source code files of the soil subroutines Executable of ORYZA2000 with example input and output files; the TTSELECT program	
Manuals		User documentation and manuals of FSE, TTUTIL, WEATHER, and TTSELECT	

Table 8.2. Example ORYZA2000 input data files in the subdirectories IR72DS92, JAK-WJ96, and IRRI and weather data files in the subdirectory WEATHER.

IR72DS92	JAK-WJ96	IRRI	WEATHER
CONTROL.DAT	CONTROL.DAT	CONTROL.DAT	INDON43.996
IR72.D92	IR64.J96	IR72.DAT	PHIL1.992
IR72DSO.T92	PJAKR.S96	IRRIDS.T92	
IR72DS1.T92	PWRTDS1.S96	SIRRI.DAT	
IR72DS2.T92	PWRTDS2.S96		
RERUNS.DAT	PWRTNS1.S96		
	RERUNS.DAT		
	WITDS1.T96		
	WITNS1.T96		
	WITNS2.T96		
	WRTDS1.T96		
	WRTDS2.T96		
	WRTNS1.T96		

Table 8.3. ORYZA2000 program files and libraries in the subdirectories S_crop, S_soil, S_main, and Libraries.

S_crop	S_soil	S_main	Libraries
PHENOL.F90	SUBSOIL.F90	ET.F90	OP_OBS.LIB
SASTRO.F90		MODELS.F90	TTUTIL.LIB
SETMKD.F90	COMMON_GWT.INC	IRRIG.F90	WEATHER.LIB
SETPMD.F90	COMMON_HYDCON.INC	NCROP.F90	
SETPTD.F90	COMMON_NUCHT.INC	NNOSTRESS.F90	
SGPC1.F90	COMMON_POWER.INC	NSOIL.F90	
SGPC2.F90	COMMON_SWIT.INC	ORYZA1.F90	
SGPCDT.F90		ORYZA2000.F90	
SGPL.F90		PADDY.F90	
SRDPRF.F90		WNOSTRESS.F90	
SSKYC.F90		WSTRESS.F90	
SUBCBC.F90			
SUBCD.F90		COMMON_GP.INC	
SUBDD.F90		COMMON_GWT.INC	
SUBGRN.F90		COMMON_HYDCON.INC	
SUBLAI2.F90		COMMON_NUCHT.INC	
SVPS1.F90		COMMON_POWER.INC	
GPPARGET.F90		COMMON_SWIT.INC	
GPPARSET.F90			

The WEATHER subdirectory contains the weather data files required to run the above three example data sets. To run any of the three, the CONTROL.DAT file from the specific directory of the data set to be run should be copied into the directory where the ORYZA2000 model is located (see more specific instructions below). Since the CONTROL.DAT file points to the location of the other input data files, it is imperative that step 1 (copying the files from the CD-ROM to your computer's hard disk) be done properly.

8.1.2 Model running under CVF

In this section, familiarity with the software Compaq Visual FORTRAN is assumed. The user is merely guided to set up a workspace and a project for ORYZA2000 and include the right programs and data files from the CD-ROM.

1. Copy the entire ORYZA directory with all subdirectories and files from the CD-ROM onto the hard disk of your computer: C:\ORYZA\...\... . Remove any read-only property of the files (see page 191 for details).
2. Start up the Developer Studio of CVF, create a new workspace (using a directory structure and name of your own choice, e.g., C:\MYNAME\ORYZA2000), and create a new project (FORTRAN Console Application; using a name of your own choice, e.g., C:\MYNAME\ORYZA2000\XNAME).
3. Add the following files to your project created above: all source files from the subdirectories ORYZA2000\S_crop, \S_main, and \S_soil and all libraries from the subdirectory ORYZA2000\Libraries (see Table 8.3).
4. Copy the files HELVB.FON, TTSELECT.EXE, and CONTROL.DAT from the subdirectory ORYZA2000 into the subdirectory with the name of your newly created workspace/project (for the example name under step 3: C:\MYNAME\ORYZA2000\XNAME). Use Windows Explorer or other software to copy the files (outside the CVF software).

ORYZA2000 is now ready to be changed, compiled, linked, and run under CVF. Upon execution, ORYZA2000 reads the file CONTROL.DAT placed in the subdirectory with the name of your newly created workspace/project and places the output in the same subdirectory. To run any of the three example data sets (IR72DS92, JAK-WJ96, IRR1) provided, the CONTROL.DAT file from the specific directory of the data set to be simulated should be copied into your workspace/project directory. Since the CONTROL.DAT file points to the location of the other input data files, it is imperative that step 1 (copying the files from the CD-ROM to your computer's hard disk) be done properly.

After running the model, you can review the generated output files OP.DAT and RESULTS.OUT in your workspace/project directory (see also Section 7.7). There is also an option to graphically quick-view the results by using the program TTSELECT. This program requires the presence of the file

HELVB.FON and reads the file RES.BIN generated by ORYZA2000. If you are working under Windows, open a DOS box and go to your workspace/project directory. Execute TTSELECT.EXE and follow the instructions on the screen. The print options of TTSELECT are not functional anymore for most computers, so just skip these options at the end of the program. After termination, TTSELECT will have created a file called TTPLOT.SET; this file can be deleted. More information on TTSELECT and its use is given in an unpublished user manual by van Kraalingen included on the CD-ROM (in the Manuals subdirectory).

8.1.3 Model running as executable

The Compaq Visual FORTRAN software is not required to merely run ORYZA200 as it is. The simplest way to install and run the model is to copy the entire ORYZA directory with all subdirectories and files from the CD-ROM onto the hard disk of your computer: C:\ORYZA\...\... . Remove any read-only property of the files (see page 191 for details).

ORYZA2000 is now ready to be run. If you're working under Windows, open a DOS box and go to the subdirectory C:\ORYZA\ORYZA2000. Execute the model ORYZA2000.EXE. Upon execution, ORYZA2000 reads the file CONTROL.DAT present in the subdirectory C:\ORYZA\ORYZA2000 and places the output in the same subdirectory. To run any of the three provided example data sets (IR72DS92, JAK-WJ96, IRR1), the CONTROL.DAT file from the specific directory of the data set to be simulated should be copied into the C:\ORYZA\ORYZA2000 directory. Since the CONTROL.DAT file points to the location of the other input data files, it is imperative that step 1 (copying the files from the CD-ROM to your computer's hard disk) be done properly.

After running the model, you can review the generated output files OP.DAT and RES.DAT in the C:\ORYZA\ORYZA2000 directory (see also Section 7.7). There is also an option to graphically quick-view the results by executing the program TTSELECT also present in the C:\ORYZA\ORYZA2000 directory. This program requires the presence of the file HELVB.FON and reads the file RES.BIN generated by ORYZA2000. Follow the instructions on the screen to graphically display the simulation results. The print options of TTSELECT are not functional anymore for most computers, so just skip these options at the end of the program. After termination, TTSELECT will have created a file called TTPLOT.SET; this file can be deleted. More information on TTSELECT and its use is given in an unpublished user manual by van Kraalingen included on the CD-ROM (in the Manuals subdirectory).

8.2 Model calibration

To use ORYZA2000 to simulate your own experiments, a set of input files needs to be created as explained in Section 7.1. The example model data files supplied on the CD-ROM can be used as a start. The experimental data file needs to contain the experimental conditions and data as explained in Section 7.2. Users should go through this data file carefully and adapt each parameter to their own experimental conditions. The soil data file is needed only when ORYZA2000 is run with a water balance (to simulate rainfed or irrigated conditions). In that case, soil physical parameters that characterize the soil under consideration are required, as explained in Section 7.4. The crop data file is always needed and contains parameters that describe the rice variety under consideration. Most of the crop parameters for rice are generic and can be used for all varieties (Section 7.3). However, some parameters and functions are best calibrated specifically for the variety and environment under consideration, namely

- Development rates
- Partitioning factors
- Relative leaf growth rate
- Specific leaf area
- Leaf death rate
- Fraction of stem reserves

These parameters should be derived from well-designed field experiments under potential production conditions, that is, without any water or nutrient limitations and without disease, pest, or weed infestation. Section 7.3 details how to calculate these parameters. Two programs are provided on the CD-ROM to help derive these parameters: DRATES for development rates and PARAM for the others (see below). If no data are available, or insufficient experimental data are available for specific calibration of these parameters, the best option is to use available parameters for IR72 or IR64 as given in the example data files on the CD-ROM. Under conditions of water limitation, the water-stress relationships in ORYZA2000 also need to be parameterized (Section 7.3). However, the derivation of the parameters governing the water-stress relationships is not easy and requires special (pot) experiments (Wopereis et al 1996a,b).

The programs DRATES and PARAM were developed using the FSE guidelines (Section 2.1) and were written in Compaq Visual FORTRAN, version 6.1, on IBM-compatible personal computers. The DRATES and PARAM programs are found in the subdirectory C:\ORYZA\CALIBRATION on the CD-ROM, together with example input data files (Table 8.1). Their source codes are found in the S_Drates and S_Param subdirectories, respectively. DRATES and PARAM are set up the same way as ORYZA2000: they read a control file that has pointers to the other input data files. This

control file is called PARAM.IN and has the same structure as the CONTROL.DAT file for ORYZA2000 (Section 7.1):

```
*-----*
*                               PARAM.IN                               *
* Run control file for parameterization programs PARAM and DRATES    *
* Date: January 2001                                                 *
*                                                                       *
* The input files (except FILEIR) can be used in reruns.            *
*-----*
FILEOP = 'PARAM.OUT'      ! Parameter output file
FILEOR = 'DRATE.OUT'     ! Development rate output file
FILEOL = 'MODEL.LOG'    ! Log file
FILEIR = ' '
FILEIT = 'c:\oryza\data\ir72ds92\IR72DS2.T92' ! Experimental data file
FILEI1 = 'IR72.DAT'      ! Crop data file
*-----*
```

PARAM.IN lists the names that are used to define input and output files, along with the directory path where they are stored. FILEOP defines the output file generated by the program PARAM and FILEOR defines the output file generated by the program DRATES. FILEOL defines the log report produced by either of the two programs. FILEIT defines the experimental data file and FILEI1 the crop data file; both are used by DRATES and PARAM. Since calibration should be done for conditions of potential production, no soil data file is needed. After the definition of input and output data files, the same set of parameters should be defined as for CONTROL.DAT (see Section 7.1; explanation not repeated here).

To set up your data files for a calibration exercise, any standard crop data file can be used that resembles the variety under consideration best, for example, IR72.DAT as a standard for IR72 or other modern high-yielding varieties. On the other hand, exactly the same experimental data file should be used as for the simulation using ORYZA2000 (Section 7.2). To calculate the ORYZA2000 parameters listed above, the following observations should be present in the experimental data file: phenology (dates of sowing, transplanting, panicle initiation, flowering, and physiological maturity), leaf area index (LAI_OBS), green leaf weight (WLVG_OBS), dead leaf weight (WLVD_OBS), stem weight (WST_OBS), and panicle weight (WSO_OBS) (all in section 8 of the experimental data file; Section 7.2). If the leaf nitrogen content on a leaf area basis (NFLV; g N m⁻² leaf) is supplied, then the leaf nitrogen content on a weight basis (FNLV; kg N kg⁻¹ dry matter leaf) is calculated as well (optional feature). It is important that the observed values for leaf area index and the weights of the canopy components all be given for the same dates of observation. If this is not the case, or if any of these parameters are missing, the model PARAM does not complete computations and generates

an error message. An example of a correct experimental data file is given by the file IR72DS2.T92 in the directory ORYZA\DATA\IR72DS92 on the CD-ROM.

After preparing the control file PARAM.IN, the crop data file, and the experimental data file, first the program DRATES should be run (see below on how to install). DRATES produces an output file (called DRATE.OUT in the example PARAM.IN file given above), which contains the calculated values of the development rate parameters DVRJ, DVRI, DVRP, and DVRR (Section 7.3). Additionally, the temperature sums TSRT, TSF, and TSM are calculated and printed, but this is just some extra information. At the end of the file, a list of day numbers is printed from the start to the end of the simulation. Next, the crop data file as specified in PARAM.IN should be adapted to reflect the calculated development rate values: change the standard values into the values computed by DRATES. Next, the program PARAM can be run. PARAM produces an output file (called PARAM.OUT in the example PARAM.IN file given above), which contains the following:

- A list of calculated development stage values (DVS) and observed values of green leaf weight (WLVG), dead leaf weight (WLVD), stem weight (WST), panicle weight (WSO), and leaf area index (LAI). A repetition of the used development rate parameters DVRJ, DVRI, DVRP, and DVRR; these values should be checked with the values generated by DRATES. All these generated data are merely for checking on consistency.
- Calculated values on the natural logarithmic of the leaf area index (LNLAI) as a function of the temperature sum (TSLV) and the temperature sum corrected for the transplanting shock (TSLVC). These data are printed only for LAI values lower than 1.5 and when DVS is below 1, and can be plotted graphically to compute the relative leaf growth rate (RGRL) (Section 3.2.9, Eqn. 3.37 and Fig. 3.12). The RGRL is also calculated and printed by PARAM between subsequent LAI data.
- A list of calculated partitioning factors (FLV, FST, and FSO) as a function of the mean development stage (DVSM) between subsequent biomass observation dates. These data can be plotted graphically to derive the partitioning tables (Section 7.3, Fig. 7.1).
- A list of calculated leaf death rate factors (DRLV) as a function of the mean development stage (DVSM) between subsequent leaf biomass observation dates. These values are computed and printed only when the leaf biomass declines.
- A list of calculated specific leaf area (SLA) as a function of development stage (DVS). These data can be plotted graphically to derive the SLA table or the smooth SLA function (Section 3.2.9, Eqn. 3.36 and Fig. 3.11).
- The calculated fraction of stem reserves (FSTR). In addition, the maximum stem weight (WSTMAX) and the development stage at which this occurs (DVSMAX) and the final stem weight (WSTEND) and the development

stage at which this occurs (DVSEND) are printed so that the user can check which data were used in the calculation.

- If the leaf nitrogen content on a leaf area basis (NFLV; g N m⁻² leaf) was supplied in the experimental data file, then a list is printed of the calculated leaf nitrogen content on a weight basis (FNLV; kg N kg⁻¹ dry matter leaf) and of the total amount of nitrogen in the crop (ANLV; kg N ha⁻¹) as a function of development stage.

At the end of the file, a list of day numbers and corresponding development stages is printed from the start to the end of the simulation.

To install and run DRATES and PARAM, follow these steps: copy the entire ORYZA directory with all subdirectories and files from the CD-ROM onto the hard disk of your computer: C:\ORYZA\...\... . Remove any read-only property of the files (see page 191 for details).

DRATES and PARAM are now ready to be run. If you are working under Windows, open a DOS box and go to the subdirectory C:\ORYZA\CALIBRATION. Execute the program DRATES.EXE. Upon execution, DRATES reads the file PARAM.IN present in the subdirectory C:\ORYZA\CALIBRATION and places the output file DRATE.OUT in the same subdirectory. Change the values of the development rate parameters DVRJ, DVRI, DVRP, and DVRR given in the file IR72.DAT (in the directory C:\ORYZA\CALIBRATION) into the values printed in the file DRATE.OUT and run the program PARAM.OUT. Disregard the error message "ERROR in OBSYS: no data for output file" after running PARAM and just press <enter> to finalize the execution. Study the output files DRATE.OUT and PARAM.OUT generated from the example data files specified in PARAM.IN.

Finally, a note of warning: "Model calibration is more an art than a science." Although model parameters can be defined exactly, their direct measurement or derivation from data collected from field experiments is often difficult. Many of the parameters addressed above require detailed measurements of various crop growth parameters with a high frequency in time. Such measurements are usually not made and one has to make do with the limited amount of data available. Many parameters, such as the partitioning tables, are derived from linear interpolation between measurements in time. If the parameter value shows abrupt changes in time, then a large time interval between measurements around the time of such abrupt changes may lead to over- or underestimation of the parameter value. If such parameter behavior is known, this can be corrected for during parameterization. An example is the derivation of the partitioning table for leaves as presented in Figure 7.1 (Section 7.3).

Needless to say, sampling and measurement errors all contribute to errors in model parameter estimation. Some parameters, such as the fraction of stem reserves, are derived from two measurements only. These measurements

should be made with a high accuracy and at a very well-defined time in the growing period. Any deviation from this will result in an error in the parameter estimation. Model calibration is an iterative procedure in which parameter values are changed slightly each time until the model performs sufficiently well while parameter values are still in acceptable agreement with the calculated values. An example is the case of the derivation of the specific leaf area (SLA) function or table in Figure 3.11 (Section 3.2.9). A fitted curve running through the top of the data points produced a more consistent and accurate simulation of crop growth across a large experimental data set than a fitted curve running through the center of the data points. It is not known whether this is caused by inaccuracies or errors in the measurements of SLA, or whether this particular calibration “corrects” for wrong or oversimplified assumptions or equations in the description of leaf area growth. A factor adding to the complexity of calibration is that many parameters interact in the process of crop growth. Therefore, it has been argued that single parameter values cannot be derived from crop observations and that sets of interacting parameters should be derived together. Klepper and Rouse (1991) presented an empirical approach to the calibration of complex crop growth simulation models.

8.3 Model validity domain

ORYZA2000 simulates the water balance and crop growth and development of lowland rice under potential, water-limited, and nitrogen-limited conditions. Under these conditions, the model has been tested widely in field experiments using modern high-yielding varieties in the tropics (e.g., IR20, IR58, IR64, and IR72 at IRRI, Philippines) and subtropics (e.g., YRL39 at Yanco, Australia). Validation results have been reported for potential production by Kropff et al (1994a,b) and Matthews et al (1995), for water-limited production by Wopereis (1993), Wopereis et al (1996a,b), and Boling et al (2000), and for nitrogen-limited production by Drenth et al (1994) and Aggarwal et al (1997). In all these experiments, the crop was well supplied with phosphorus and potassium and the fields were kept free from weeds, pests, and diseases as much as possible. Under such conditions, ORYZA2000 is expected to perform equally well for other varieties and in other environments if proper calibration is performed (Section 8.2). ORYZA2000 was not tested on hybrid rice or upland rice varieties; with these rice types, possibly more of the crop parameters than suggested in Section 8.2 would need to be reparameterized.

The parameters that characterize the rice plant’s response to drought stress were derived from pot experiments using IR20 and IR72. Wopereis (1993) found that, with these parameter values, the ORYZA_W model (one of the forerunners of ORYZA2000) simulated the growth and development of IR72 in drought experiments under field conditions at IRRI very well. However, care must be taken to use these parameter values for other varieties as it is well

known that different varieties display different resistance to drought (e.g., Lilley and Fukai 1994). Boling et al (2000) used the IR20/IR72 parameter values for drought stress to simulate the behavior of IR64 under irrigated and rainfed conditions in Jakenan, Indonesia, and concluded that ORYZA2000 performed sufficiently well to use it for extrapolation studies. However, from their analysis, they also concluded that ORYZA2000 did not simulate crop growth well under conditions of extreme drought stress that resulted in measured yields of 0.5 to 1.0 t ha⁻¹. ORYZA2000 does not model the emergence and growth of new (ratoon) tillers upon rewetting after a period of severe drought. Although the model takes a large number of drought stress effects on rice growth and development into consideration, we think that it is still relatively weak in modeling root water uptake and spikelet sterility with drought during flowering. The soil-water balance PADDY was designed especially for puddled soils. It has been tested against field experiments and against other (more detailed) water-balance models using data from field experiments conducted at IRRI (Wopereis 1993, Wopereis et al 1996a).

Drenth et al (1994) and Aggarwal et al (1997) validated ORYZA-N (a forerunner of ORYZA2000) under conditions of nitrogen limitations using data from field experiments conducted in the Philippines (IRRI) and in India (various locations). We validated ORYZA2000 using field experiments conducted at IRRI between 1991 and 1993 with different N fertilizer rates (from 0 to 400 kg ha⁻¹) and fertilizer N splits (from 1 to 7), and concluded that the model performed well (Figs. 8.1 and 8.2). Although the simulation of nitrogen dynamics in the crop is relatively detailed, the simulation of nitrogen dynamics in the soil is relatively weak. The soil nitrogen module is basically a bookkeeping algorithm using empirically derived model parameters (Section 5.2). The model parameters for soil at the IRRI farm as presented in the example data files cannot be extrapolated to other environments, but need to be derived site specifically (Section 7.2). In the future, more deterministic soil nitrogen models can be developed and integrated in ORYZA2000. The modeling of nitrogen limitations on leaf growth in the early phase of crop growth (the so-called exponential growth phase) needs further investigation and validation. No effects of nitrogen limitations on crop development rate are modeled.

Although ORYZA2000 was tested under conditions of water and nitrogen limitations separately, it was not validated for conditions of combined water and nitrogen limitations. Despite this lack of validation, we chose to keep this combination in place so that users could test and (dis-)validate ORYZA2000 for this situation themselves and modify the model accordingly. ORYZA2000 has not been tested for upland rice under upland (nonpuddled soil) growing conditions.

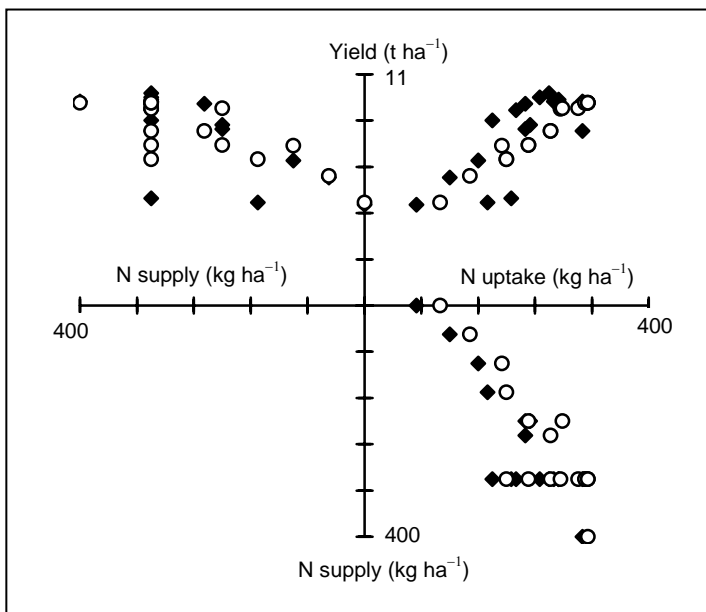

Fig. 8.1. Three-quadrant graph of observed (\blacklozenge) and simulated (\circ) N uptake and yield versus fertilizer N supply. Data from IR72 in the dry season of 1993, at IRRI, under 17 N regimes (N rates ranging from 0 to 400 kg ha⁻¹, and splits from 1 to 7).

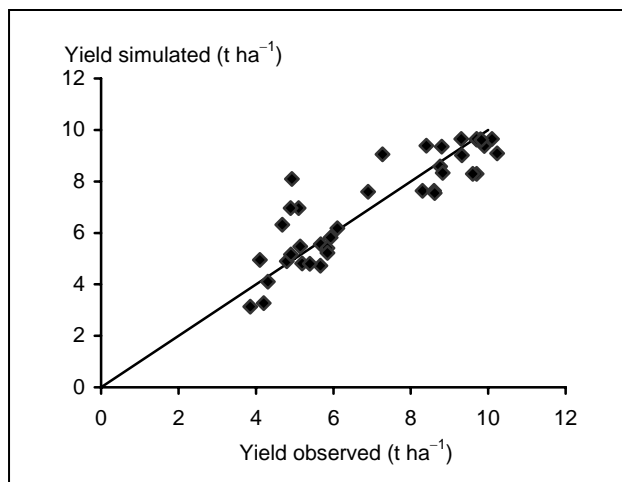

Fig. 8.2. Simulated versus observed yields of irrigated IR72 with data from five experiments at IRRI between 1991 and 1993, under various N management regimes (N rates ranging from 0 to 400 kg ha⁻¹, and splits from 1 to 7). N = 39.

8.4 Model applications

Crop growth modeling serves the main aim of increasing our insights into crop growth processes by a synthesis of knowledge expressed in mathematical equations (Bouman et al 1996). Simulation models are powerful tools for testing our understanding of crop performance by comparing simulation results and experimental observations, thus making gaps in our knowledge explicit. Experiments can then be designed to fill these gaps. Once a model is validated, it can be used to help analyze and interpret field experiments, and in more application-oriented research and operational applications. The following applications can be made with ORYZA2000:

- *Detailed physiological analysis of field experiments.* To use ORYZA2000 for this purpose, the simulation mode should be “EXPERIMENT” (as defined by the parameter RUNMODE in the experimental data file; Section 7.2). An example of such an application is the interpretation of treatment differences in yield in terms of LAI development, leaf N content, weather conditions, and varietal characteristics that determine physiological and morphological processes (Kropff et al 1994b). Detailed measurements are required on LAI and leaf N content, preferably throughout the growing season. It is useful to analyze experimental data with LAI as an input as a first step, because the carbon-balance part of the model is better developed and tested than the morphological part (Kropff et al 1994a). So, inaccuracy in the simulation of morphological characteristics cannot confound conclusions made in the first analysis if LAI is used as an input. As a second step, LAI can be simulated as well. If no experimental data are available, LAI has to be simulated. In the model, an assumed time course of leaf N content or the actual measured data can be used. If different N application regimes are part of the experimental treatments, the next step would be to use the model with the full nitrogen balance.
- *Estimation of crop performance in a given environment.* Applications of this type include agroecological zonation, yield prediction, and yield gap and yield risk analysis (e.g., Lansigan et al 1997, and case studies presented by Bouman et al 1993b). All these applications basically entail the extrapolation of experimental findings to other environments characterized by climate, geographic location, soil type, and management. To use ORYZA2000 for these purposes, the simulation mode should be “EXPLORATION” (as defined by the parameter RUNMODE in the experimental data file; Section 7.2). Yield can be predicted under any defined management package (emergence date, establishment characteristics, irrigation, nitrogen fertilizer) under different climates and on different soil types. A special case of the prediction of crop performance is that under expected climate change (Kropff et al 1993, Matthews et al 1995). ORYZA2000 has a special provision to allow changes in daily

temperature without having to change weather data files (Section 7.2). If ORYZA2000 is run with the water-balance PADDY, it can estimate differences between potential and rainfed yield and calculate the amount of irrigation water required to obtain potential yield (Bouman et al 1993a).

- *Management optimization.* For a given biophysical environment (climate, soil), ORYZA2000 can be used to optimize crop management parameters such as emergence date, stand density, irrigation application, and fertilizer nitrogen management. The simulation mode should be “EXPLORATION” (as defined by the parameter RUNMODE in the experimental data file; Section 7.2). Boling et al (2000) used ORYZA2000 to estimate potential and rainfed rice yields in Jakenan, Indonesia, and to explore irrigation management options to increase current actual yields.
- *Breeding and germplasm evaluation.* ORYZA2000 can be used to simulate the effects of changes in the morphological and physiological characteristics of rice and thus aid in the identification of ideotypes for different environments (Aggarwal et al 1997, Dingkuhn et al 1991, Kropff et al 1995, Yin et al 1997). Palanisamy et al (1993) proposed that crop growth models that have been parameterized for new cultivars in field experiments can be used to simulate the long-term yield stability of these cultivars at a location under the expected range of climatic conditions.

References

- Aggarwal PK, Kropff MJ, Cassman KG, ten Berge HFM. 1997. Simulating genotypic strategies for increasing rice yield potential in irrigated tropical environments. *Field Crops Res.* 51:5-17.
- Akita S. 1980. Studies on the differences in photosynthesis and photorespiration among crops. II. The differential responses of photosynthesis, photorespiration and dry matter production to carbon dioxide concentration among species. *Bull. Natl. Inst. Agric. Sci. (Ser. D)* 31:59-94.
- Amthor JS. 1984. The role of maintenance respiration in plant growth. *Plant Cell Environ.* 7:561-569.
- Barnett KH, Pearce RB. 1983. Source-sink ratio alteration and its effect on physiological parameters in maize. *Crop Sci.* 23:294-299.
- Boling A, Tuong TP, Bouman BAM, Murty MVR, Jatmiko SY. 2000. Effect of climate, agrohydrology and management on rainfed rice production in Central Java, Indonesia: a modeling approach. In: Tuong TP, Kam SP, Wade L, Pandey S, Bouman BAM, Hardy B, editors. *Characterizing and understanding rainfed environments. Proceedings of the International Workshop on Characterizing and Understanding Rainfed Environments, 5-9 December 1999, Bali, Indonesia.* Los Baños (Philippines): International Rice Research Institute. p 57-74.
- Bouman BAM, Penning de Vries FWT, Riethoven JJM, Kropff MJ, Wopereis MCS. 1993a. Application of simulation and systems analysis in rice cropping optimization. In: Bouman BAM, van Laar HH, Zhaoqian W, editors. *Agro-ecology of rice-based cropping systems.* SARP Research Proceedings. Wageningen (Netherlands): IRRI/AB-DLO. p 1-15.
- Bouman BAM, van Laar HH, Zhaoqian W, editors. 1993b. *Agro-ecology of rice-based cropping systems, SARP Research Proceedings.* Wageningen (Netherlands): IRRI/AB-DLO. 201 p.
- Bouman BAM, Wopereis MCS, Kropff MJ, ten Berge HFM, Tuong TP. 1994. Water use efficiency of flooded rice fields. II. Percolation and seepage losses. *Agric. Water Manage.* 26:291-304.
- Bouman BAM, van Keulen H, van Laar HH, Rabbinge R. 1996. The 'School of de Wit' crop growth simulation models: pedigree and historical overview. *Agric. Sys.* 52:171-198.
- Bouman BAM, Tuong TP. 2001. Field water management to save water and increase its productivity in irrigated rice. *Agric. Water Manage.* 49/1:11-30.
- Brouwer R. 1965. Root growth of grasses and cereals. In: Milthorpe FL, Ivins JD, editors. *The growth of cereals and grasses.* London (UK): Butterworths. p 153-166.
- Bronswijk JJB. 1988. Modelling of water balance, cracking and subsidence of clay soils. *J. Hydrol.* 97:199-212.

- Bronswijk JJB. 1989. Prediction of actual cracking and subsidence in clay soils. *Soil Sci.* 148:87-93.
- Cassman KG, Kropff MJ, Zhende Y. 1994. A conceptual framework for nitrogen management of irrigated rice in high yield environments. In: Virmani SS, editor. *Hybrid rice technology: new developments and future prospects*. Los Baños (Philippines): International Rice Research Institute. p 81-96.
- Cruz RT, O'Toole JC. 1984. Dryland rice response to an irrigation gradient at flowering stage. *Agron. J.* 76:178-183.
- De Datta SK. 1981. *Principles and practices of rice production*. Singapore: John Wiley and Sons. 618 p.
- De Datta SK. 1986. Improving nitrogen fertilizer efficiency in lowland rice in tropical Asia. *Fert. Res.* 9:171-186.
- de Wit CT. 1958. Transpiration and crop yields. *Agricultural Research Reports* 64.6. Wageningen (Netherlands): Pudoc. 88 p.
- de Wit CT, Penning de Vries FWT. 1982. L'analyse des systèmes de production primaire. In: Penning de Vries FWT, Djitéye MA, editors. *La productivité des pâturages sahéliens. Une étude des sols, des végétations et de l'exploitation de cette ressource naturelle*. Agric. Res. Rep. 918. Wageningen (Netherlands): Pudoc. p 20-27.
- de Wit CT, Goudriaan J, van Laar HH, Penning de Vries FWT, Rabbinge R, van Keulen H, Sibma L, de Jonge C. 1978. Simulation of assimilation, respiration and transpiration of crops. *Simulation Monographs*. Wageningen (Netherlands): Pudoc. 141 p.
- Dingkuhn M, Penning de Vries FWT, De Datta SK, van Laar HH. 1991. Concept for a new plant type for direct seeded flooded tropical rice. In: *Direct seeded flooded rice in the tropics. Selected papers from the International Rice Research Conference, 27-31 Aug. 1990, Seoul, Korea*. Los Baños (Philippines): International Rice Research Institute. p 17-38.
- Drenth H, ten Berge FFM, Riethoven JJM. 1994. ORYZA simulation modules for potential and nitrogen limited rice production. *SARP Research Proceedings*. Wageningen (Netherlands): IRRI/AB-DLO. 223 p.
- Ehleringer J, Pearcy RW. 1983. Variation in quantum yield for CO₂ uptake among C₃ and C₄ plants. *Plant Physiol.* 73:555-559.
- Ekanayake IJ, De Datta SK, Steponkus PL. 1989. Spikelet sterility and flowering response of rice to water stress at anthesis. *Ann. Bot.* 63:257-264.
- FAO (Food and Agriculture Organization). 1998. *Crop evaporation: guidelines for computing crop water requirements*. Irrigation and Drainage Paper 56. FAO, Rome. 300 p.
- Ferguson JA. 1970. Effect of flooding depth on rice yield and water balance. *Arkansas Farm Res.* 19(3):4.
- Fischer RA. 1985. Number of kernels in wheat crops and the influence of solar radiation and temperature. *Camb. J. Agric. Sci.* 105:447-461.

- Frère M, Popov GF. 1979. Agrometeorological crop monitoring and forecasting. Plant Production Protection Paper 17. Rome: Food and Agricultural Organization. 64 p.
- Gao LZ, Jin ZQ, Huang Y, Zhang LZ. 1992. Rice clock model: a computer model to simulate rice development. *Agric. Forest Meteorol.* 60:1-16.
- Goudriaan J. 1977. Crop micrometeorology: a simulation study. *Simulation Monographs*. Wageningen (Netherlands): Pudoc. 257 p.
- Goudriaan J. 1982. Some techniques in dynamic simulation. In: Penning de Vries FWT, van Laar HH, editors. *Simulation of plant growth and crop production*. *Simulation Monographs*. Wageningen (Netherlands): Pudoc. p 66-84.
- Goudriaan J. 1986. A simple and fast numerical method for the computation of daily totals of canopy photosynthesis. *Agric. Forest Meteorol.* 43:251-255.
- Goudriaan J, van Laar HH. 1994. *Simulation of crop growth processes*. Dordrecht (Netherlands): Kluwer Academic Publishers. 238 p.
- Hasegawa S, Yoshida S. 1982. Water uptake by dryland rice root system during soil drying cycle. *Soil Sci. Plant Nutr.* 28(2):191-204.
- Horie T. 1988. The effects of climatic variations on agriculture in Japan. 5. The effects on rice yields in Hokkaido. In: Parry ML, Carter TL, Konijn NT, editors. *The impact of climatic variations on agriculture*. Vol. 1: Assessments in cool temperature and cold regions. Dordrecht (Netherlands): Kluwer Academic Publishers. p 809-826.
- Horie T. 1993. Predicting the effects of climatic variation and effect of CO₂ on rice yield in Japan. *Jpn. Agric. Meteorol.* (Tokyo) 48:567-574.
- Horie T, de Wit CT, Goudriaan J, Bensink J. 1979. A formal template for the development of cucumber in its vegetative stage. *Proceedings of the Koninklijke Nederlandse Akademie van Wetenschappen. Series C.* 82(4):433-479.
- Horie T, Yajima M, Nakagawa H. 1992. Yield forecasting. *Agric. Sys.* 40:211-236.
- IRRI (International Rice Research Institute). 1992. Program report for 1992. Manila (Philippines): IRRI. 316 p.
- IRRI (International Rice Research Institute). 1997. *Rice almanac*. Second edition. Manila (Philippines): IRRI. 181 p.
- Islam MS, Morison JIL. 1992. Influence of solar radiation and temperature on irrigated rice grain yield in Bangladesh. *Field Crops Res.* 30:13-28.
- Jansen DM. 1990. Potential rice yields in future weather conditions in different parts of Asia. *Neth. J. Agric. Sci.* 38:661-680.
- Kampen J. 1970. Water losses and water balance studies in lowland rice irrigation. PhD thesis. Cornell University, USA. 416 p.
- Kiniry JR, Rosenthal WD, Jackson BS, Hoogenboom G. 1991. Predicting leaf development of crop plants. In: Hodges T, editor. *Predicting crop phenology*. Boca Raton, Fla. (USA): CRC Press. p 29-42.
- Klepper O, Rouse DI. 1991. A procedure to reduce parameter uncertainty for complex models by comparison with real system output illustrated on a potato growth model. *Agric. Sys.* 36:375-395.

- Kropff MJ, Cassman KG, Penning de Vries FWT, van Laar HH. 1993. Increasing the yield plateau in rice and the role of global climate change. *J. Agric. Meteorol.* 48:795-798.
- Kropff MJ, Cassman KG, van Laar HH. 1994b. Quantitative understanding of the irrigated rice ecosystem for increased yield potential. In: Virmani SS, editor. *Hybrid rice technology: new developments and future prospects*. Manila (Philippines): International Rice Research Institute. p 97-113.
- Kropff MJ, Haverkort AJ, Aggarwal PK, Kooman PL. 1995. Using systems approaches to design and evaluate ideotypes for specific environments. In: Bouma J, Kuyvenhoven A, Bouman BAM, Luyten JC, Zandstra HG, editors. *Eco-regional approaches for sustainable land use and food production*. Dordrecht (Netherlands): Kluwer Academic Publishers. p 417-435.
- Kropff MJ, van Laar HH, Matthews RB, editors. 1994a. *ORYZA1: an ecophysiological model for irrigated rice production*. SARP Research Proceedings. Wageningen (Netherlands): IRRI/AB-DLO. 110 p.
- Lansigan FP, Pandey S, Bouman BAM. 1997. Combining crop modelling with economic risk analysis for the evaluation of crop management strategies. *Field Crops Res.* 51(1,2):133-145.
- Leffelaar PA, editor. 1993. *On systems analysis and simulation of ecological processes: with examples in CSMP and FORTRAN*. Current issues in production ecology. Vol. 1. Dordrecht (Netherlands): Kluwer Academic Publishers. 294 p.
- Lilley JM, Fukai S. 1994. Effect of timing and severity of water deficit on four diverse rice cultivars. II. Physiological responses to soil water deficit. *Field Crops Res.* 37:215-223.
- Louwerse W, Sibma L, van Kleef J. 1990. Crop photosynthesis, respiration and dry matter production of maize. *Neth. J. Agric. Sci.* 38:95-108.
- Makkink GF. 1957. Testing the Penman formula by means of lysimeters. *Int. J. Water Eng.* 11:277-288.
- Matsui T, Horie T. 1992. Effect of elevated CO₂ and high temperature on growth and yield of rice. 2. Sensitive period and pollen germination rate in high temperature sterility of rice spikelets at flowering. *Jpn. J. Crop Sci.* 61:148-149.
- Matthews RB, Hunt LA. 1994. A model describing the growth of cassava (*Manihot esculenta* L. Crantz). *Field Crops Res.* 36:69-84.
- Matthews RB, Kropff MJ, Bachelet D, van Laar HH. 1995. *Modelling the impact of climate change on rice production in Asia*. Wallingford (UK): CAB International. 304 p.
- Monteith JL. 1969. Light interception and radiative exchange in crop stands. In: Eastin JD, Haskins FA, Sullivan CY, van Bavel CHM, editors. *Physiological aspects of crop yield*. Madison, Wis. (USA): American Society of Agronomy, Crop Science Society of America. p 89-111.
- Moorman FR, van Breemen N. 1978. *Rice: soil, water, land*. Los Baños (Philippines): International Rice Research Institute. 185 p.

- O'Toole JC, Chang TT. 1979. Drought resistance in cereals—rice: a case study. In: Mussel H, Staples R, editors. *Stress physiology in crop plants*. New York (USA): Wiley-Interscience. p 373-405.
- O'Toole JC, Cruz R. 1980. Response of leaf water potential, stomatal resistance and leaf rolling to water stress. *Plant Physiol.* 65:428-432.
- O'Toole JC, Hsiao TC, Namuco OS. 1984. Panicle water relations during water stress. *Plant Sci. Lett.* 33:137-143.
- O'Toole JC, Moya TB. 1981. Water deficits and yield in upland rice. *Field Crops Res.* 4:247-259.
- Palanisamy S, Penning de Vries FWT, Mohandass S, Thiyagarajan TM, Kareem AA. 1993. Simulation in pre-testing of rice genotypes in Tamil Nadu. In: Penning de Vries FWT, Teng P, Metselaar K, editors. *Systems approaches for sustainable agricultural development*. Dordrecht (Netherlands): Kluwer Academic Publishers. p 63-75.
- Peng S, Cassman KG. 1998. Upper thresholds of nitrogen uptake rates and associated nitrogen fertilizer efficiencies in irrigated rice. *Agron. J.* 90(2):178-185.
- Penman HL. 1948. Natural evaporation from open water, bare soil and grass. *Proc. Royal Soc. London Ser. A* 193:120-146.
- Penman HL. 1956. Evaporation: an introductory survey. *Neth. J. Agric. Sci.* 4:9-29.
- Penning de Vries FWT. 1975. The costs of maintenance processes in plant cells. *Ann. Bot.* 39:77-92.
- Penning de Vries FWT, van Laar HH, editors. 1982. *Simulation of plant growth and crop production*. Simulation Monographs. Wageningen (Netherlands): Pudoc. 308 p.
- Penning de Vries FWT, Brunsting AHM, van Laar H. 1974. Products, requirements and efficiency of biosynthesis: a quantitative approach. *J. Theor. Biol.* 45:339-377.
- Penning de Vries FWT, Jansen DM, ten Berge HFM, Bakema A. 1989. Simulation of ecophysiological processes of growth in several annual crops. *Simulation Monographs*. Wageningen (Netherlands): Pudoc. 271 p.
- Priestley CHB, Taylor RJ. 1972. On the assessment of the surface heat flux and evaporation using large scale parameters. *Monthly Weather Rev.* 100:81-92.
- Puckridge DW, O'Toole JC. 1981. Dry matter and grain production of rice, using a line source sprinkler in drought studies. *Field Crops Res.* 3:303-319.
- Sanchez PA. 1973. Puddling tropical rice soils. 2. Effects of water losses. *Soil Sci.* 115(4):303-308.
- Satake T, Yoshida S. 1978. High temperature-induced sterility in Indica rice at flowering. *Jpn. J. Crop Sci.* 47:6-17.
- Setter TL, Peng S, Kirk GJD, Virmani SS, Kropff MJ, Cassman KG. 1994. Physiological considerations and hybrid rice. In: Cassman KG, editor. *Breaking the yield barrier*. Proceedings of the workshop on rice yield and yield potential in favorable environments. International Rice Research Institute, 29 November-4 December 1993, Los Baños, Philippines. p 39-62.

- Spitters CJT. 1986. Separating the diffuse and direct component of global radiation and its implications for modeling canopy photosynthesis. II. Calculations of canopy photosynthesis. *Agric. Forest Meteorol.* 38:231-242.
- Spitters CJT, Toussaint HAJM, Goudriaan J. 1986. Separating the diffuse and direct component of global radiation and its implications for modelling canopy photosynthesis. I. Components of incoming radiation. *Agric. Forest Meteorol.* 38:217-229.
- Spitters CJT, van Keulen H, van Kraalingen DWG. 1989. A simple and universal crop growth simulator: SUCROS87. In: Rabbinge R, Ward SA, van Laar HH, editors. *Simulation and systems management in crop protection. Simulation Monographs.* Wageningen (Netherlands): Pudoc. p 147-181.
- Summerfield RJ, Collinson ST, Ellis RH, Roberts EH, Penning de Vries FWT. 1992. Photothermal responses of flowering in rice (*Oryza sativa*). *Ann. Bot.* 69:101-112.
- Takahashi J. 1975. Studies on the improvement of rice culture in the eastern part of Tohoku District. *Bull. Miyagi Prefecture Agric. Res. Ctr.* 45:1-58.
- Tanguilig VC, Yambao EB, O'Toole JC, De Datta SK. 1987. Water stress effects on leaf elongation, leaf water potential, transpiration, and nutrient uptake of rice, maize and soybean. *Plant Soil* 103:155-168.
- Tanner CB, Sinclair TR. 1983. Efficient use of water in crop production: research or research. In: Taylor HM, Jordan WR, Sinclair TR, editors. *Limitations to efficient water use in crop production.* Madison, Wis. (USA): American Society of Agronomy-Crop Science Society of America-Soil Science Society of America. p 1-27.
- Taylor HM, Klepper B. 1978. The role of rooting characteristics in the supply of water to plants. *Adv. Agron.* 30:99-128.
- ten Berge HFM. 1989. Heat and water transfer in bare topsoil and lower atmosphere. *Simulation Monographs* 33. Wageningen (Netherlands): Pudoc. 200 p.
- ten Berge HFM, Jansen DM, Rappoldt K, Stol W. 1992. The soil water balance module SAWAH: description and users guide. CABO-TT Sim. Rep. Ser. 22. Wageningen (Netherlands): CABO. 78 p.
- ten Berge HFM, Kropff MJ. 1995. Founding a systems research network for rice. In: Bouma J, Kuyvenhoven A, Bouman BAM, Luyten JC, Zandstra HG, editors. *Eco-regional approaches for sustainable land use and food production.* Dordrecht (Netherlands): Kluwer Academic Publishers. p 263-282.
- ten Berge HFM, Thiyagarajan TM, Shi Q, Wopereis MCS, Drenth H, Jansen MJW. 1997. Numerical optimization of nitrogen application to rice. Part I. Description of MANAGE-N. *Field Crops Res.* 51:29-42.
- Tuong TP, Wopereis MCS, Marques JA, Kropff MJ. 1994. Mechanisms and control of percolation losses in puddled rice fields. *Soil Sci. Soc. Am. J.* 58(6):1794-1803.
- Turner NC, O'Toole JC, Cruz RT, Namuco OS, Ahmad S. 1986. Responses of seven diverse rice cultivars to water deficits. I. Stress development, canopy temperature, leaf rolling and growth. *Field Crops Res.* 13:257-271.

- Uchijima T. 1976. Some aspects of relation between low air temperature and sterile spikelets in rice plants. *J. Agric. Meteorol.* 31:199-202.
- van Diepen CA, van Keulen H, Penning de Vries FWT, Noy IGAM, Goudriaan J. 1987. Simulated variability of wheat and rice yields in current weather conditions and in future weather when ambient CO₂ had doubled. CABO-TT Simulation Report Series 22. Wageningen (Netherlands): CABO. 40 p.
- van Diepen CA, Rappoldt C, Wolf J, van Keulen H. 1988. Crop growth simulation model WOFOST. Documentation version 4.1. Centre for World Food Studies. Amsterdam (Netherlands): Wageningen. 299 p.
- van Genuchten MTh. 1980. A closed-form equation for predicting the hydraulic properties of unsaturated soils. *Soil Sci. Soc. Am. J.* 44:892-898.
- van Genuchten MTh, Leij FJ, Yates SR. 1991. The RETC code for quantifying the hydraulic functions of unsaturated soils. Ada, Okla. (USA): United States Environmental Protection Agency. 85 p.
- van Keulen H, Penning de Vries FWT, Drees EM. 1982. A summary model for crop growth. In: Penning de Vries FWT, van Laar HH, editors. *Simulation of plant growth and crop production. Simulation Monographs.* Wageningen (Netherlands): Pudoc. p 87-97.
- van Keulen H, Wolf J, editors. 1986. *Modelling of agricultural production: weather, soils and crops. Simulation Monographs.* Wageningen (Netherlands): Pudoc. 479 p.
- van Keulen H, Seligman NG. 1987. Simulation of water use, nitrogen and growth of a spring wheat crop. *Simulation Monographs.* Wageningen (Netherlands): Pudoc. 310 p.
- van Kraalingen DWG, Stol W, Uithol PWJ, Verbeek M. 1991. User manual of CABO/TPE weather system. Internal communication. Wageningen (Netherlands): CABO/TPE. 27 p.
- van Kraalingen DWG. 1995. The FSE system for crop simulation: version 2.1. *Quantitative Approaches in Systems Analysis Report 1.* Wageningen (Netherlands): C.T. de Wit Graduate School for Production Ecology and AB-DLO. 58 p.
- van Kraalingen DWG, Stol W. 1997. Evapotranspiration modules for crop growth simulation. *Quantitative Approaches in Systems Analysis 11.* Wageningen (Netherlands): C.T. de Wit Graduate School for Production Ecology and AB-DLO. 29 p.
- van Kraalingen DWG, Rappoldt C. 2000. Reference manual of the FORTRAN utility library TTUTIL v. 4. *Quantitative Approaches in Systems Analysis.* Wageningen (Netherlands): C.T. de Wit Graduate School for Production Ecology and AB-DLO. 103 p.
- van Laar HH, Goudriaan J, van Keulen H, editors. 1997. SUCROS97: simulation of crop growth for potential and water-limited production situations. *Quantitative Approaches in Systems Analysis 14.* Wageningen (Netherlands): C.T. de Wit Graduate School for Production Ecology and AB-DLO. 52 p.

- Vergara BS, Chang TT. 1985. The flowering response of the rice plant to photoperiod: a review of the literature. Los Baños (Philippines): International Rice Research Institute. 61 p.
- Wagener JL. 1980. FORTRAN77, principles of programming. New York: John Wiley and Sons. 370 p.
- Wickham TH, Singh VP. 1978. Water movement through wet soils. In: Soils and rice. Los Baños (Philippines): International Rice Research Institute. p 337-357.
- Wolfram S. 1991. Mathematica: a system for doing mathematics by computer. Second edition. Redwood City, Calif. (USA): Addison-Wesley Publishing Company, Inc. 961 p.
- Wopereis MCS. 1993. Quantifying the impact of soil and climate variability on rainfed rice production. PhD thesis. Wageningen (Netherlands): Wageningen Agricultural University. 188 p.
- Wopereis MCS, Wösten JHM, Bouma J, Woodhead T. 1992. Hydraulic resistance in puddled rice soils: measurement and effects on water movement. *Soil Tillage Res.* 24:199-209.
- Wopereis MCS, Wösten JHM, ten Berge HFM, Woodhead T, de San Agustin EMA. 1993a. Comparing the performance of a soil-water balance model using measured and calibrated hydraulic conductivity data: a case study for dryland rice. *Soil Sci.* 156(3):133-140.
- Wopereis MCS, Kropff MJ, Wösten JHM, Bouma J. 1993b. Sampling strategies for measurement of soil hydraulic properties to predict rice yield using simulation models. *Geoderma* 59:1-20.
- Wopereis MCS, Kropff MJ, Bouma J, van Wijk ALM, Woodhead T, editors. 1994a. Soil physical properties: measurement and use in rice-based cropping systems. Los Baños (Philippines): International Rice Research Institute, 104 p.
- Wopereis MCS, Bouman BAM, Kropff MJ, ten Berge HFM, Maligaya AR. 1994b. Water use efficiency of flooded rice fields. I. Validation of the soil-water balance model SAWAH. *Agric. Water Manage.* 26:277-289.
- Wopereis MCS, Bouman BAM, Tuong TP, ten Berge HFM, Kropff MJ. 1996a. ORYZA_W: rice growth model for irrigated and rainfed environments. SARP Research Proceedings. Wageningen (Netherlands): IRRI/AB-DLO. 159 p.
- Wopereis MCS, Kropff MJ, Maligaya AR, Tuong TP. 1996b. Drought-stress responses of two lowland rice cultivars to soil water status. *Field Crops Res.* 46:21-39.
- Yin X. 1996. Quantifying the effects of temperature and photoperiod on phenological development to flowering of rice. PhD thesis. Wageningen (Netherlands): Wageningen Agricultural University. 173 p.
- Yin X, Kropff MJ, Aggarwal PK, Peng S, Horie T. 1997. Optimal preflowering phenology of irrigated rice for high yield potential in three Asian environments: a simulation study. *Field Crops Res.* 51:19-27.
- Yoshida S. 1981. Fundamentals of rice crop science. Manila (Philippines): International Rice Research Institute, 269 p.

Yoshida S, Parao FT. 1976. Climatic influence on yield and yield components of lowland rice in the tropics. In: *Climate and rice*. Los Baños (Philippines): International Rice Research Institute. p 471-494.

List of variables

Variable	Description	Used in subroutine	Units
ALAI	Apparent leaf area index (including stem area)	ORYZA1	ha leaf ha ⁻¹ soil
ALB	Albedo, reflection coefficient for short-wave radiation	ET	-
AMAX	CO ₂ assimilation rate at light saturation	SGPC1, SGPC2, SGPCDT,	kg CO ₂ ha ⁻¹ leaf h ⁻¹
AMAX1	Uncorrected CO ₂ assimilation rate at light saturation	ORYZA1	-
AMAX2	Corrected CO ₂ assimilation rate at light saturation	SGPL	kg CO ₂ ha ⁻¹ leaf h ⁻¹
ANCR	Amount of N in crop (live and dead material)	NCROP	kg N ha ⁻¹
ANCRF	Amount of N in crop till flowering	NCROP	kg N ha ⁻¹
ANCRPT	Potential amount of N in crop	NCROP	kg N ha ⁻¹
ANGA	Ångström parameter A	ET, MODELS	-
ANGB	Ångström parameter B	ET, MODELS	-
ANGOT	Daily extraterrestrial radiation	SASTRO,	J m ⁻² d ⁻¹
ANLD	Amount of N in dead leaves	SGPCDT	-
ANLV	Amount of N in leaves	NCROP	kg N ha ⁻¹
ANLVA	Amount of N in leaves till flowering	NCROP	kg N ha ⁻¹
ANSO	Amount of N in storage organs	NCROP	kg N ha ⁻¹
ANST	Amount of N in stems	NCROP	kg N ha ⁻¹
ANSTA	Amount of N in stems till flowering	NCROP	kg N ha ⁻¹
AOB	Intermediate variable	SASTRO	-
ASLA	A parameter of function to calculate SLA	ORYZA1	-
ATMTR	Atmospheric transmission coefficient	SSKYC	-
ATN	Total available N for translocation from leaves, stems, and roots	NCROP	kg N ha ⁻¹
ATNLV	Total available N for translocation from leaves	NCROP	kg N ha ⁻¹
ATNRT	Total available N for translocation from roots	NCROP	kg N ha ⁻¹
ATNST	Total available N for translocation from stems	NCROP	kg N ha ⁻¹
BSLA	B parameter of function to calculate SLA	ORYZA1	-
CAPRI	Array of capillary rise, per soil layer	PADDY	mm d ⁻¹
CAPTOT	Total capillary rise	PADDY	mm d ⁻¹
CBCHK	Carbon balance check, relative value to sums of CKIN and CKCFL	ORYZA1, SUCBC	-
CKCFL	Sum of integrated carbon fluxes into and out of crop	ORYZA1, SUCBC	kg C ha ⁻¹
CKCIN	Carbon in crop accumulated since simulation started	ORYZA1, SUCBC	kg C ha ⁻¹
CKWFL	Total of external contribution to system water content	PADDY	mm
CKWIN	Total change in system water content	PADDY	mm
CLUSTF	Cluster factor	SRDPRF	-
CO2	Ambient CO ₂ concentration	ORYZA1	ppm
CO2EFF	Relative effect of CO ₂ on initial light-use efficiency	ORYZA1	-
CO2LV	CO ₂ production factor for growth of leaves	ORYZA1	kg CO ₂ kg ⁻¹ DM
CO2REF	Reference level of atmospheric CO ₂ (340 ppm)	ORYZA1	ppm
CO2RT	CO ₂ production factor for growth of roots	ORYZA1	kg CO ₂ kg ⁻¹ DM
CO2SO	CO ₂ production factor for growth of storage organs	ORYZA1	kg CO ₂ kg ⁻¹ DM
CO2ST	CO ₂ production factor for growth of stems	ORYZA1	kg CO ₂ kg ⁻¹ DM
CO2STR	CO ₂ production factor for growth of stem reserves	ORYZA1	kg CO ₂ kg ⁻¹ DM
COLDTT	Accumulated cold degree days	SUBGRN	°Cd
COSLD	Intermediate variable in calculating solar height	SASTRO, SGPCDT, SSKYC	-
CRACKS	Logical indicating if cracks penetrate through puddle topsoil	PADDY	-

Variable	Description	Used in subroutine	Units
CRGCR	Carbohydrate (CH ₂ O) requirement for dry matter production	ORYZA1	kg CH ₂ O kg ⁻¹ DM
CRGLV	Carbohydrate requirement for leaf dry matter production	ORYZA1	kg CH ₂ O kg ⁻¹ DM
CRGRT	Carbohydrate requirement for root dry matter production	ORYZA1	kg CH ₂ O kg ⁻¹ DM
CRGSO	Carbohydrate requirement for storage organ dry matter production	ORYZA1	kg CH ₂ O kg ⁻¹ DM
CRGST	Carbohydrate requirement for stem dry matter production	ORYZA1	kg CH ₂ O kg ⁻¹ DM
CRGSTR	Carbohydrate requirement for stem reserves production	ORYZA1	kg CH ₂ O kg ⁻¹ DM
CROPSTA	Crop stage	Most subroutines	-
CSLA	C parameter of function to calculate SLA	ORYZA1	-
CSLV	Scattering coefficient of leaves for photosynthetically active radiation	SGPC1, SGPCDT, SGPC2, SGPL, SRDPRF	-
CTRANS	Carbon losses at transplanting	ORYZA1	kg C ha ⁻¹
CTT	Cold degree day	SUBGRN	°Cd
DAE	Days after emergence	MODELS, NSOIL, ORYZA1	d
DAYL	Astronomic daylength (base = 0 degrees)	ORYZA1, PHENOL, SGPCDT, SASTRO	h
DAYLP	Photoperiodic astronomic daylength (base = -4 degrees)	ORYZA1, PHENOL, SGPCDT, SASTRO	h
DEC	Declination of sun	SASTRO	radians
DEGRAD	Conversion factor from degrees to radians	SASTRO	radians degree ⁻¹
DEL	Intermediate variable for numerical integration	SGPC2	-
DELT	Time interval of integration	Most subroutines	d
DL	Photoperiod daylength	PHENOL	h
DLDR	Death rate of leaves caused by drought	MODELS, NCROP, ORYZA1, SUBLAI2	kg DM ha ⁻¹ d ⁻¹
DLDR	Total death rate of leaves caused by drought	ORYZA1	kg DM ha ⁻¹ d ⁻¹
DLEAF	Control variable for start of leaf senescence by drought	ORYZA1	kg DM ha ⁻¹ d ⁻¹
DOY	Day number (January 1 = 1)	GWYTAB, IRRIG, MODELS, ORYZA1, PADDY, SASTRO	d
DPAR	Daily incoming photosynthetically active radiation	ORYZA1	MJ m ⁻² d ⁻¹
DPARI	The amount of photosynthetically active radiation that is absorbed in a day by canopy	ORYZA1	MJ m ⁻² d ⁻¹
DRAIN	Flux of water to drain soil layer to field capacity	PADDY	mm d ⁻¹
DRAIN	Cumulative outflow from deepest soil layer, from main field	PADDY	mm
DRAICU	Cumulative outflow from deepest soil layer, since start of simulation	PADDY	mm
DRLVT	Table for leaf death coefficient as function of DVS	ORYZA1	-, d ⁻¹
DROUT	Control variable indicating drought/no drought	ORYZA1	-
DSINB	Daily total of sine of solar height	SASTRO	s d ⁻¹
DSINBE	As DSINB, but with a correction for lower atmospheric transmission at lower solar elevations	SASTRO, SGPCDT, SSKYC	s d ⁻¹
DSL	D parameter of function to calculate SLA	ORYZA1	-
DSPW	Days passed without ponded water on soil surface	PADDY	d
DT	Estimated temperature difference between surface height and reference height	ET	°C
DTGA	Daily total gross CO ₂ assimilation of crop	ORYZA1	kg CO ₂ ha ⁻¹ d ⁻¹
DTR	Daily total global radiation	ORYZA1	J m ⁻² d ⁻¹
DVEW	Effect of water stress on development rate	ORYZA1	-
DVR	Development rate of crop	ORYZA1, PHENOL	°Cd ⁻¹
DVRI	Development rate during photoperiod-sensitive phase	ORYZA1, PHENOL	°Cd ⁻¹
DVRJ	Development rate during juvenile phase	ORYZA1, PHENOL	°Cd ⁻¹
DVRP	Development rate during panicle development phase	ORYZA1, PHENOL	°Cd ⁻¹

Variable	Description	Used in subroutine	Units
DVRR	Development rate in reproductive phase (post anthesis)	ORYZA1, PHENOL	°Cd ⁻¹
DVS	Development stage of crop	Most subroutines	-
DVSF	Development stage of crop at flowering	SUBGRN	-
DVSI	Initial value of development stage of crop	ORYZA1	-
DVSP1	Development stage of crop at panicle initiation	SUBGRN	-
ECPBL	Extinction coefficient for direct radiation	SRDPRF	-
ECPDF	Extinction coefficient for diffuse radiation	SGPC1, SGPC2, SGPL, SGPCDT, SRDPRF	-
ECPTD	Extinction coefficient for direct component of direct radiation	SRDPRF	-
EFF	Initial light-use efficiency	SGPC1, SGPC2, SGPCDT, ORYZA1	(kg CO ₂ ha ⁻¹ leaf h ⁻¹)(W m ⁻² leaf) ⁻¹
EFF1	Uncorrected initial light-use efficiency	SGPL	(kg CO ₂ ha ⁻¹ leaf h ⁻¹)(W m ⁻² leaf) ⁻¹
EFF2	Corrected initial light-use efficiency	SGPL	(kg CO ₂ ha ⁻¹ leaf h ⁻¹)(W m ⁻² leaf) ⁻¹
EFFTB	Table of EFF as function of temperature	ORYZA1	EFF, °C
EMD	Day of emergence	MODELS	d
EMYR	Year of emergence	MODELS	y
EPS	Intermediate variable for numerical integration	SGPC2	-
ESTAB	Method of crop establishment	MODELS, ORYZA1, PADDY, SUBLAI2	-
ETAE	Dryness-driven part of reference evapotranspiration rate	ET	mm d ⁻¹
ETD	Reference evapotranspiration rate	ET, MODELS	mm d ⁻¹
ETMOD	Name of evapotranspiration procedure	ET, MODELS	-
ETRD	Radiation-driven part of reference evapotranspiration rate	ET	mm d ⁻¹
EVSC	Potential evaporation rate of soil or ponded water layer	ET, MODELS, PADDY	mm d ⁻¹
EVSD	Actual evaporation rate of soil if DSPW > 1	PADDY	mm d ⁻¹
EVSH	Actual evaporation rate of soil if DSPW = 1	PADDY	mm d ⁻¹
EVS	Actual evaporation rate of soil	PADDY	mm d ⁻¹
EVSWC	Cumulative actual evaporation, from main field	PADDY	mm
EVSWCU	Cumulative actual evaporation, since start of simulation	PADDY	mm
EVSWS	Actual evaporation rate of soil layer 1	BACKFL, DOWNFL, PADDY	mm d ⁻¹
FACT	Soil-water tension	PADDY	pF
FAOF	FAO correction factor on potential evapotranspiration rate	ET, MODELS	-
FCLV	Mass fraction of carbon in leaves	ORYZA1	kg C kg ⁻¹ DM
FCRT	Mass fraction of carbon in roots	ORYZA1	kg C kg ⁻¹ DM
FCSO	Mass fraction of carbon in storage organs	ORYZA1	kg C kg ⁻¹ DM
FCST	Mass fraction of carbon in stems	ORYZA1	kg C kg ⁻¹ DM
FCSTR	Mass fraction of carbon in stem reserves	ORYZA1	kg C kg ⁻¹ DM
FERT	Daily fertilizer N application rate	NSOIL	kg N ha ⁻¹ d ⁻¹
FERTIL	Table of daily fertilizer N application as function of time	NSOIL	d, kg N ha ⁻¹ d ⁻¹
FILEI1	Name of crop data file	MODELS, NCROP, NNOSTRESS, ORYZA1, WSTRESS	-
FILEI2	Name of soil data file	MODELS, PADDY	-
FILEI3	Name of input file no. 3	MODELS	-
FILEI4	Name of input file no. 4	MODELS	-
FILEI5	Name of input file no. 5	MODELS	-
FILEIT	Name of experimental data file	IRRIG, MODELS, NSOIL, NNOSTRESS, ORYZA1	-
FIXPERC	Constant percolation rate	PADDY	mm d ⁻¹

Variable	Description	Used in subroutine	Units
FLIN	Flux into soil layer	BACKFL, DOWNFL	mm d ⁻¹
FLNEW	Boundary flow between soil layers recalculated via subroutine BACKFL	BACKFL, PADDY	mm d ⁻¹
FLOUT	Flux out of soil layer	BACKFL, DOWNFL	mm d ⁻¹
FLOW	Capillary rise calculated by subroutine SUBSL2	PADDY	mm d ⁻¹
FLV	Fraction of shoot dry matter allocated to leaves	ORYZA1	-
FLVTB	Table of FLV as function of DVS	ORYZA1	-, -
FNLV	Fraction of N in leaves on weight basis	NCROP	kg N kg ⁻¹ DM
FNLVI	Initial fraction of N in leaves on weight basis	NCROP	kg N kg ⁻¹ DM
FNSO	Fraction of N in storage organs	NCROP	kg N kg ⁻¹ DM
FNST	Fraction of N in stems	NCROP	kg N kg ⁻¹ DM
FNTRT	Fraction of N translocated from stems and leaves, which is translocated from roots to storage organs	NCROP	-
FRDIF	Fraction of diffuse radiation	SSKYC	-
FRPAR	Fraction of short-wave radiation that is photosynthetically active	ORYZA1, SGPCDT, SSKYC	- -
FRT	Fraction of total dry matter allocated to roots	ORYZA1	-
FSH	Fraction of total dry matter allocated to shoots	ORYZA1	-
FSHTB	Table of FSH as function of DVS	ORYZA1	-, -
FSLLA	Fraction of leaf area that is sunlit	SGPL, SRDPRF	-
FSO	Fraction of shoot dry matter allocated to storage organs	ORYZA1	-
FSOTB	Table of FSO as function of DVS	ORYZA1	-, -
FST	Fraction of shoot dry matter allocated to stems	ORYZA1	-
FSTR	Fraction of carbohydrates allocated to stems, stored as reserves	ORYZA1	-
FSTTB	Table of FST as function of DVS	ORYZA1	-, -
GAI	Green area index	SGPC1, ha leaf ha ⁻¹ soil SGPC2, SGPCDT, SGPL	
GAID	Green area index above selected height	SGPC1, ha leaf ha ⁻¹ soil SGPL, SRDPRF	
GCR	Gross growth rate of crop	ORYZA1, kg DM ha ⁻¹ d ⁻¹ SUBGRN	
GGR	Rate of increase in grain weight	MODELS, kg DM ha ⁻¹ d ⁻¹ ORYZA1	
GIVEN	Logical parameter	MODELS	-
GLAI	Growth rate of leaf area index	ORYZA1, ha ha ⁻¹ d ⁻¹ SUBLAI2	
GLAI1	Intermediate value of GLAI	SUBLAI2	ha ha ⁻¹ d ⁻¹
GLAI2	Intermediate value of GLAI	SUBLAI2	ha ha ⁻¹ d ⁻¹
GLV	Growth rate of leaves	MODELS, kg ha ⁻¹ d ⁻¹ ORYZA1, NCROP	
GNGR	Rate of increase in grain number	ORYZA1, no. ha ⁻¹ d ⁻¹ SUBGRN	
GNSP	Rate of increase in spikelet number	ORYZA1, no. ha ⁻¹ d ⁻¹ SUBGRN	
GPC	Instantaneous CO ₂ assimilation rate of canopy	SGPC1, kg CO ₂ ha ⁻¹ h ⁻¹ SGPC2, SGPCDT	
GPCDT	Daily total gross assimilation	SGPCDT	kg CO ₂ ha ⁻¹ d ⁻¹
GPCO	Intermediate variable for numerical integration	SGPC2	-
GPCT	Intermediate variable for numerical integration	SGPC2	-
GPCTO	Intermediate variable for numerical integration	SGPC2	-
GPL	Instantaneous CO ₂ assimilation rate of leaves at depth GAI	SGPL, kg CO ₂ ha ⁻¹ leaf h ⁻¹ SGPC1	

Variable	Description	Used in subroutine	Units
GPL1	Intermediate variable for numerical integration	SGPC2	-
GPL2	Intermediate variable for numerical integration	SGPC2	-
GPSHL	Gross CO ₂ assimilation rate of shaded leaves	SGPL	kg CO ₂ ha ⁻¹ leaf h ⁻¹
GPSLL	Gross CO ₂ assimilation rate of sunlit leaves	SGPL	kg CO ₂ ha ⁻¹ leaf h ⁻¹
GRAINS	Logical parameter indicating whether grains are formed	ORYZA1, SUBGRN	-
GRWAT	Logical parameter indicating if groundwater is in soil profile	PADDY	-
GRT	Growth rate of roots	ORYZA1	kg DM ha ⁻¹ d ⁻¹
GRT1	Reduction in root weight at transplanting	ORYZA1	kg DM ha ⁻¹
GSO	Growth rate of storage organs	MODELS,	kg DM ha ⁻¹ d ⁻¹
		NCROP, ORYZA1	
GST	Growth rate of stems	MODELS,	kg DM ha ⁻¹ d ⁻¹
		NCROP, ORYZA1	
GST1	Reduction in stem weight at transplanting	ORYZA1	kg DM ha ⁻¹
GSTR	Growth rate of stem reserves	ORYZA1	kg DM ha ⁻¹ d ⁻¹
GSW	Array of 3 weighting factors for Gaussian integration	SGPC1,	-
		SGPCDT, SGPL	
G SX	Array of 3 locations/points for Gaussian integration	SGPC1,	-
		SGPCDT, SGPL	
GWCHK	Check variable for presence of groundwater in soil layers	PADDY	-
GWCU	Cumulative contribution of water flux to groundwater, since start of simulation	PADDY	mm
GWFILL	Water flux to "fill up" soil layer if in groundwater	PADDY	mm d ⁻¹
GWTOT	Total contribution of water flux from groundwater	PADDY	mm d ⁻¹
GZRT	Growth rate of root length	ORYZA1	m d ⁻¹
HLP	Intermediate variable	BACKFL	mm
HOURL	Hour for which calculations should be done	SGPCDT, SSKYC	h
HU	Daily heat units effective for phenological development	ORYZA1,	°Cd d ⁻¹
		PHENOL, SUBDD	
HULV	Daily heat units effective for leaf area development	ORYZA1, SUBLAI2	°Cd d ⁻¹
I	Counter	Many subroutines	-
I1	Counter	Many subroutines	-
I2	Counter	PADDY	-
IACC	Switch to determine the accuracy of assimilation calculations	SGPCDT	-
IDATE	Return value of function DTFSECMP, indicating whether the day of simulation has reached the emergence day	MODELS	-
IDOY	Day number within year of simulation	ET, MODELS, ORYZA1,	d
		SASTRO, SGPC1,	
		SGPCDT	
IGSN	Parameter value for Gaussian integration	SGPC1,	-
		SGPCDT, SGPL	
IGW	Number of shallowest soil layer in groundwater	GW TAB, PADDY	-
ILDRLV	Length of array DRLVT	ORYZA1	-
ILEFFT	Length of array EFFT B	ORYZA1	-
ILFERT	Length of array FERTIL	NSOIL	-
ILFLVT	Length of array FLVTB	ORYZA1	-
ILFSHT	Length of array FSHTB	ORYZA1	-
ILFSOT	Length of array FSOTB	ORYZA1	-
ILFSTT	Length of array FSTTB	ORYZA1	-
ILKDFT	Length of array KDFTB	ORYZA1	-
ILKNFT	Length of array KNFTB	ORYZA1	-
ILNFLV	Length of array NFLVTB	NCROP, NNOSTRESS	-
ILNMAX	Length of array NMAXLT	NCROP	-
ILNMIN	Length of array NMINLT	NCROP	-
ILNMNS	Length of array NMINSOT	NCROP	-

Variable	Description	Used in subroutine	Units
ILPMAX	Maximum array length of PERTB	PADDY	-
ILREC	Length of array RECNT	NSOIL	-
ILREDF	Length of array REDFTT	ORYZA1	-
ILSLAT	Length of array SLATB	ORYZA1	-
ILSSGA	Length of array SSGATB	ORYZA1	-
ILTMCT	Length of array TMCTB	ORYZA1	-
IMX	Maximum length of array (of a number of array variables)	NCROP, ORYZA1	-
IMX	Maximum length of array NFLVTB	NNOSTRESS	-
INL	Counter	WSTRESS	-
INSLLV	Length of array NSLLVT	NCROP	-
INX	Maximum length of arrays (a number of variables)	NSOIL	-
IPERTB	Length of array PERTB	PADDY	-
IR	Amount of daily irrigation	IRRIG, MODELS, PADDY	mm d ⁻¹
IRC	Cumulative amount of irrigation water applied in main field	IRRIG	mm
IRCU	Cumulative amount of irrigation, since start of simulation	PADDY	mm
IRIRR	Number of days of irrigation application	IRRIG	d
IRRI	Amount of daily irrigation	IRRIG	mm d ⁻¹
ISURF	Switch parameter to choose between surface types	ET	-
IT	Counter for numerical integration	SGPC2	-
ITASK	Task that subroutine should perform	Most subroutines	-
IUNITD	Unit number that can be used for input files	Most subroutines	-
IUNITL	Unit number for log file messages	Most subroutines	-
IUNITO	Unit number that is used for output file	MODELS	-
IYEAR	Year of simulation	MODELS	y
J	Counter	SGPC2, PADDY, WSTRESS	-
K	Counter	PADDY	-
KDF	Extinction coefficient for leaves	ORYZA1	-
KDFTB	Table of KDF as function of development stage (DVS)	ORYZA1	-, -
KEEP	Variable to temporarily store value of LDSTRS	ORYZA1	-
KNF	Extinction coefficient of nitrogen profile in canopy	ORYZA1	-
KNFTB	Table of KNF as function of development stage (DVS)	ORYZA1	-, -
KPAMIN	Minimum soil-water tension in soil layer SLMIN at which to apply irrigation	IRRIG	kPa
KSAT	Array of saturated hydraulic conductivity, per soil layer	DOWNFL, PADDY	cm d ⁻¹
KST	Array of saturated hydraulic conductivity, per soil layer	PADDY	cm d ⁻¹
LAI	Leaf area index	ET, MODELS, NCROP, ORYZA1, SUBLAI2	ha leaf ha ⁻¹ soil
LAIEXP	Value of LAI at end of exponential growth phase after transplanting	SUBLAI2	ha leaf ha ⁻¹ soil
LAIEXS	Value of LAI at end of exponential growth phase in seedbed	SUBLAI2	ha leaf ha ⁻¹ soil
LAIROL	Rolled leaf area index caused by drought	MODELS, ORYZA1	ha leaf ha ⁻¹ soil
LAPE	Leaf area per plant at emergence	ORYZA1	m ² pl ⁻¹
LAT	Latitude of weather station	ET, MODELS, ORYZA1, SASTRO, SGPCDT	dec. degr.
LD	Array of drought factors accelerating leaf death, per soil layer	WSTRESS	-
LDAV	Drought factor accelerating leaf death, mean over all soil layers	WSTRESS	-
LDSTRS	Drought stress factor accelerating leaf death	MODELS, ORYZA1, WNOSTRESS, WSTRESS	-

Variable	Description	Used in subroutine	Units
LE	Array of drought stress factors reducing leaf expansion, per soil layer	WSTRESS	-
LEAV	Drought stress factor reducing leaf expansion, mean over all soil layers	WSTRESS	-
LESTRS	Drought stress factor reducing leaf expansion	MODELS, ORYZA1, SUBLAI2, WNOSTRESS, WSTRESS	-
LLDL	Lower limit of drought-induced dead leaves	WSTRESS	pF
LLLE	Lower limit of leaf expansion	WSTRESS	pF
LLLS	Lower limit of leaf rolling	WSTRESS	pF
LLRT	Lower limit of relative transpiration	WSTRESS	pF
LLV	Loss rate of leaf weight	MODELS, NCROP, ORYZA1	kg DM ha ⁻¹ d ⁻¹
LR	Array of drought stress factors causing leaf rolling, per soil layer	WSTRESS	-
LRAV	Drought stress factor causing leaf rolling, mean over all soil layers	WSTRESS	-
LRSTR	Fraction of allocated stem reserves that is available for growth	ORYZA1	-
LRSTRS	Drought stress factor causing leaf rolling	MODELS, ORYZA1, SUBGRN, WSTRESS, WNOSTRESS	-
LSTR	Loss rate of stem reserves	ORYZA1	kg DM ha ⁻¹ d ⁻¹
MAINLV	Maintenance respiration coefficient of leaves	ORYZA1	kg CH ₂ O kg ⁻¹ DM d ⁻¹
MAINRT	Maintenance respiration coefficient of roots	ORYZA1	kg CH ₂ O kg ⁻¹ DM d ⁻¹
MAINSO	Maintenance respiration coefficient of storage organs	ORYZA1	kg CH ₂ O kg ⁻¹ DM d ⁻¹
MAINST	Maintenance respiration coefficient of stems	ORYZA1	kg CH ₂ O kg ⁻¹ DM d ⁻¹
MAXGW	Maximum groundwater table depth	PADDY	cm
MINGW	Minimum groundwater table depth	PADDY	cm
MNDVVS	Factor accounting for effect of DVS on maintenance respiration	ORYZA1	-
MNL	Maximum array length (of various array variables)	PADDY	-
MOPP	Maximum optimum photoperiod	ORYZA1, PHENOL	h
MS	Array of soil-water tension (suction), per soil layer	PADDY	cm H ₂ O
MSKPA	Array of soil-water tension, per soil layer	IRRIG, MODELS, PADDY, WSTRESS	kPa
MSUC	Array of soil-water tension (suction), per soil layer	PADDY	cm H ₂ O
N	Counter	SGPC2	-
NACR	Actual nitrogen uptake rate by crop	MODELS, NCROP, NSOIL	kg N ha ⁻¹ d ⁻¹
NACRS	Cumulative amount of nitrogen taken up by crop	NCROP	kg N ha ⁻¹
NALV	Actual nitrogen uptake rate by leaves	NCROP	kg N ha ⁻¹ d ⁻¹
NALVS	Cumulative amount of nitrogen taken up by leaves	NCROP	kg N ha ⁻¹
NASO	Actual nitrogen uptake rate by storage organs	NCROP	kg N ha ⁻¹ d ⁻¹
NASOS	Cumulative amount of nitrogen taken up by storage organs	NCROP	kg N ha ⁻¹
NAST	Actual nitrogen uptake rate by stems	NCROP	kg N ha ⁻¹ d ⁻¹
NASTS	Cumulative amount of nitrogen taken up by stems	NCROP	kg N ha ⁻¹
NBCHK	Balance of nitrogen balance check	NCROP	kg N ha ⁻¹
NCHCK	Balance of nitrogen uptake	NCROP	kg N ha ⁻¹
NCOLD	Number of cold days	ORYZA1, SUBCD	d
NDEMC	Potential daily N demand by crop	NCROP	kg N ha ⁻¹ d ⁻¹
NDEML	Potential daily N demand by leaves	NCROP	kg N ha ⁻¹ d ⁻¹
NDEMS	Potential daily N demand by stems	NCROP	kg N ha ⁻¹ d ⁻¹
NDEMSN	Minimum daily N demand by storage organs	NCROP	kg N ha ⁻¹ d ⁻¹

Variable	Description	Used in subroutine	Units
NDEMSX	Potential daily N demand by storage organs	NCROP	kg N ha ⁻¹ d ⁻¹
NFERTP	Total fertilizer N pool in soil	NSOIL	kg N ha ⁻¹
NFLV	Nitrogen fraction in leaves on leaf area basis	MODELS, NCROP, NNOSTRESS, ORYZA1	g N m ⁻² leaf
NFLV1	Intermediate value for NFLV	NNOSTRESS	g N m ⁻² leaf
NFLVI	Initial nitrogen fraction in leaves on leaf area basis	NCROP, NNOSTRESS	g N m ⁻² leaf
NFLVTB	Table of NFLV as function of development stage	NNOSTRESS	-, g N m ⁻² leaf
NFLVP	Maximum (potential) N fraction in leaves on leaf area basis	NCROP	g N m ⁻² leaf
NFLVTB	Table of NFLV as function of development stage (DVS)	NCROP	-, g N m ⁻² leaf
NGCR	Net growth rate of crop, including translocation	ORYZA1	kg ha ⁻¹ d ⁻¹
NGR	Number of grains	ORYZA1	no ha ⁻¹
NGRM2	Number of grains	ORYZA1	no m ⁻²
NH	Number of hills	ORYZA1, SUBLAI2	hills m ⁻²
NITROENV	Name of production environment with respect to nitrogen	MODELS	-
NL	Number of soil layers	ET, GWTAB, IRRIG, MODELS, PADDY, WNOSTRESS, WSTRESS	-
NLDLV	N loss rate because of death of leaves	NCROP	kg N ha ⁻¹ d ⁻¹
NLPUD	Number of puddled soil layers including plow sole	PADDY	-
NLV	Daily net flow rate of N to the leaves	NCROP	kg N ha ⁻¹ d ⁻¹
NLVAN	Daily net flow rate of N to the leaves before flowering	NCROP	kg N ha ⁻¹ d ⁻¹
NLXM	Maximum number of soil layers	MODELS	-
NMAX	Intermediate variable for numerical integration	SGPC2	-
NMAXL	Maximum N fraction in leaves on weight basis	NCROP	kg N kg ⁻¹ DM
NMAXLT	Relationship between NMAXL and DVS (table)	NCROP	-, kg N kg ⁻¹ DM
NMAXSO	Maximum N fraction in storage organs	NCROP	kg N kg ⁻¹ DM
NMINL	Minimum N fraction in leaves on weight basis	NCROP	kg N kg ⁻¹ DM
NMINLT	Table of NMINL as function of development stage (DVS)	NCROP	-, kg N kg ⁻¹ DM
NMINSO	Minimum N fraction in storage organs	NCROP	kg N kg ⁻¹ DM
NMINLOT	Table of NMINSO as function of ANCRF	NCROP	kg N ha ⁻¹ , kg N kg ⁻¹ DM
NPLDS	Number of plants direct-seeded in main field	ORYZA1	pl m ⁻²
NPLH	Number of plants per hill	ORYZA1, SUBLAI2	pl hill ⁻¹
NPLSB	Number of plants in seedbed	ORYZA1, SUBLAI2	pl m ⁻²
NSHKLV	Correction for leaf-N loss because of transplanting	NCROP	-
NSHKST	Correction for stem-N loss because of transplanting	NCROP	-
NLLV	N stress factor that accelerates leaf death	MODELS, NCROP, ORYZA1, NNOSTRESS	-
NLLVT	Table of NLLV as function of NSTRES	NCROP	-, -
NSO	Net flow rate of N to storage organs	NCROP	kg N ha ⁻¹ d ⁻¹
NSP	Number of spikelets	ORYZA1, SUBGRN	no. ha ⁻¹
NSPM2	Number of spikelets	ORYZA1	no. m ⁻²
NST	Net flow rate of N to stems	NCROP	kg N ha ⁻¹ d ⁻¹
NSTAN	Net flow rate of N to stems before flowering	NCROP	kg N ha ⁻¹ d ⁻¹
NSTRES	Ratio of maximum over actual amount of N in crop	NCROP	-
NTFERT	Number of days of flowering period	SUBGRN	d
NTLV	Actual N translocation rate to storage organs from leaves	NCROP	kg N ha ⁻¹ d ⁻¹
NTRT	Actual N translocation rate to storage organs from roots	NCROP	kg N ha ⁻¹ d ⁻¹
NTRTS	Amount of N translocated from roots to storage organs	NCROP	kg N ha ⁻¹

Variable	Description	Used in subroutine	Units
NTSO	Actual N translocation rate to storage organs from leaves, stems and roots	NCROP	kg N ha ⁻¹ d ⁻¹
NTST	Actual N translocation rate to storage organs from stems	NCROP	kg N ha ⁻¹ d ⁻¹
OUTPUT	Flag to indicate if output should be done	Many subroutines	-
PARCM1	Cumulative amount of radiation absorbed by canopy based on the simple calculation of daily absorbed radiation	ORYZA1	MJ m ⁻²
PARCUM	Cumulative amount of radiation absorbed by canopy based on detailed calculation of daily absorbed radiation	ORYZA1	MJ m ⁻²
PARI1	Amount of photosynthetically active radiation absorbed on a day by canopy	ORYZA1	MJ m ⁻² d ⁻¹
PCEW	Effect of drought stress on daily total gross CO ₂ assimilation of crop; reduction in potential transpiration rate	MODELS, ORYZA1, WNOSTRESS, WSTRESS	-
PERC	Actual percolation rate	PADDY	mm d ⁻¹
PERCC	Cumulative percolation, from main field	PADDY	mm
PERCOL	Constant percolation rate	PADDY	mm d ⁻¹
PERTB	Table of constant percolation rate as function of groundwater table depth	PADDY	cm, mm d ⁻¹
PFCR	Critical soil-water tension at which cracks break through soil layer	PADDY	pF
PI	Ratio of circumference to diameter of circle	SASTRO	-
PLTR	Intermediate variable for change in plant density at transplanting	MODELS, NCROP, ORYZA1	-
PN	Parameter n in power function for hydraulic conductivity	PADDY	-
PPFAC	Factor determining photoperiod sensitivity	PHENOL	-
PPSE	Photoperiod sensitivity	ORYZA1, PHENOL	h ⁻¹
PRODEVN	Name of production environment with respect to water	MODELS	-
PROREL	Contribution of profile storage to water balance	PADDY	mm d ⁻¹
PUDDL	Logical switch indicating if profile is puddled/nonpuddled	PADDY	-
PWRR	Potential weight of rough rice	ORYZA1	kg ha ⁻¹
Q10	Factor accounting for increase in maintenance respiration with a 10 °C rise in temperature	ORYZA1	-
RAIN	Daily amount of rainfall	MODELS, PADDY	mm d ⁻¹
RAINC	Cumulative rainfall, on main field	PADDY	mm
RAINCU	Cumulative amount of rainfall since start of simulation	MODELS, PADDY	mm
RAPC	Instantaneous absorbed photosynthetically active radiation	SGPC1, SGPCDT	W m ⁻² leaf
RAPCDT	Daily rate of absorbed photosynthetically active radiation	ORYZA1, SGPCDT	J m ⁻² d ⁻¹
RAPCO	Intermediate variable for numerical integration	SGPC2	-
RAPCT	Intermediate variable for numerical integration	SGPC2	-
RAPCTO	Intermediate variable for numerical integration	SGPC2	-
RAPDDL	Absorbed flux of direct component of direct radiation	SRDPRF	W m ⁻² leaf
RAPDFL	Absorbed flux of diffuse radiation	SRDPRF	W m ⁻² leaf
RAPL	Absorbed photosynthetically active radiation in canopy	SGPC1	W m ⁻² soil
RAPL	Absorbed radiation at depth GAI	SGPL	W m ⁻² leaf
RAPL1	Intermediate variable for numerical integration	SGPC2	-
RAPL2	Intermediate variable for numerical integration	SGPC2	-
RAPPPL	Direct flux absorbed by leaves perpendicular on direct beam	SGPL, SRDPRF	W m ⁻² leaf
RAPSHL	Absorbed flux for shaded leaves	SGPL, SRDPRF	W m ⁻² leaf
RAPSL	Total absorbed radiation	SGPL	W m ⁻² leaf
RAPTDL	Absorbed flux of total direct radiation	SRDPRF	W m ⁻² leaf
RDAE	Rate to calculate days after emergence	ORYZA1	d ⁻¹

Variable	Description	Used in subroutine	Units
RDD	Daily short-wave radiation	ET, MODELS, ORYZA1, SGPCDT, SSKYC	$\text{J m}^{-2} \text{d}^{-1}$
RDPDF	Flux of diffuse radiation at particular time of day	SGPCDT	W m^{-2}
RDPDF	Instantaneous flux of diffuse photosynthetically active radiation	SGPC1, SGPC2, SGPL, SRDPRF, SSKYC	W m^{-2}
RDPDR	Instantaneous flux of direct photosynthetically active radiation	SGPC1, SGPC2, SGPCDT, SGPL, SRDPRF, SSKYC	W m^{-2}
RECNIT	Table of N recovery fraction (RECOV) vs. development stage (DVS)	NSOIL	-, -
RECOV	Recovery fraction of fertilizer N in the soil	NSOIL	-
REDFT	Factor accounting for effect of temperature on AMAX	ORYZA1	-
REDFTT	Table of REDFT as function of temperature	ORYZA1	$^{\circ}\text{C}$, -
REST	Rest of water component in top soil layer calculated by subroutine BACKFL	PADDY	mm
RF	Surface reflection coefficient	ET	-
RFLH	Reflection coefficient of crop with horizontal leaf angle distribution	SRDPRF	-
RFLS	Reflection coefficient of crop with spherical leaf angle distribution	SRDPRF	-
RFNLV	Residual N fraction of leaves	NCROP	$\text{kg N kg}^{-1} \text{DM}$
RFNST	Residual N fraction of stems	NCROP	$\text{kg N kg}^{-1} \text{DM}$
RFS	Surface reflection coefficient	ET	-
RGCR	Growth respiration rate of crop	ORYZA1	$\text{kg CO}_2 \text{ha}^{-1} \text{d}^{-1}$
RGRL	Relative growth rate for leaf development	ORYZA1, SUBLAI2	$^{\circ}\text{Cd}^{-1}$
RGRLMN	Maximum value of relative growth rate of leaf area	ORYZA1, SUBLAI2	$^{\circ}\text{Cd}^{-1}$
RGRLMX	Minimum value of relative growth rate of leaf area	ORYZA1, SUBLAI2	$^{\circ}\text{Cd}^{-1}$
RIRRIT	Table of irrigation water application, as function of day number	IRRIG	d, mm
RIWCLI	Switch to indicate resetting of ponded water depth at transplanting	PADDY	-
RMCR	Maintenance respiration rate of crop	ORYZA1	$\text{kg CH}_2\text{O ha}^{-1} \text{d}^{-1}$
RNOFCU	Cumulative runoff, since start of simulation	PADDY	mm
RNSTRS	Reduction factor on relative leaf growth rate caused by N stress	MODELS, NCROP, NNOSTRESS, ORYZA1, SUBLAI2	-
RTNASS	Net rate of total CO_2 assimilation by crop	ORYZA1	$\text{kg CO}_2 \text{ha}^{-1} \text{d}^{-1}$
RUNMODE	Name of mode in which ORYZA2000 is run	MODELS	-
RUNOF	Runoff rate	PADDY	mm d^{-1}
RUNOFC	Cumulative runoff, from main field	PADDY	mm
RWCLI	Logical switch to indicate resetting or not of ponded water depth at transplanting	PADDY	-
RWLVG	Growth rate of green leaves	ORYZA1, SUBLAI2	$\text{kg ha}^{-1} \text{d}^{-1}$
RWLVG1	Reduction in leaf weight at transplanting	ORYZA1	kg ha^{-1}
RWSTR	Net growth rate of stem reserves	ORYZA1	$\text{kg ha}^{-1} \text{d}^{-1}$
RWSTR1	Reduction in stem reserve weight at transplanting	ORYZA1	kg ha^{-1}
SAI	Stem area index	ORYZA1	ha leaf ha^{-1} soil
SBDUR	Duration of seedbed	MODELS	d
SCODE	Name of soil-water balance model	PADDY	-
SCP	Scattering coefficient of leaves for photosynthetically active radiation	ORYZA1	-
SF1	Spikelet sterility factor because of low temperatures	ORYZA1, SUBGRN	-
SF2	Spikelet fertility factor because of high temperatures	ORYZA1, SUBGRN	-
SHCKD	Delay parameter in phenology	ORYZA1, PHENOL	$^{\circ}\text{Cd} (^{\circ}\text{Cd})^{-1}$

Variable	Description	Used in subroutine	Units
SHCKL	Delay parameter in development	ORYZA1, SUBLAI2	°Cd (°Cd) ⁻¹
SINB	Sine of solar height	SGPC1, SGPC2, SGPCDT, SGPL, SRDPRF, SSKYC	-
SINLD	Intermediate variable in calculating solar declination	SASTRO, SGPCDT, SSKYC	-
SLA	Specific leaf area	ORYZA1, SUBLAI2	ha leaf kg ⁻¹ leaf
SLAMAX	Maximum value of specific leaf area	ORYZA1	ha leaf kg ⁻¹ leaf
SLATB	Table of SLA as function of DVS	ORYZA1	-, ha leaf kg ⁻¹ leaf
SLMIN	Number of soil layer that serves as determinant for irrigation application	IRRIG	-
SOILSP	Nitrogen mineralization rate	NSOIL	kg N ha ⁻¹ d ⁻¹
SOLCON	Solar constant at day = IDOY	SASTRO, SGPCDT, SSKYC	W m ⁻²
SOLHM	Hour of day at which solar height is maximum	SSKYC	h
SPFERT	Spikelet fertility factor	ORYZA1, SUBGRN	-
SPGF	Spikelet growth factor	ORYZA1, SUBGRN	no. kg ⁻¹
SSGA	Specific green stem area	ORYZA1	ha stem kg ⁻¹ stem
SSGATB	Table of SSGA as function of DVS	ORYZA1	-, -
STTIME	Start day of simulation	MODELS	d
SUM1	Intermediate variable for numerical integration	SGPC2	-
SUM2	Intermediate variable for numerical integration	SGPC2	-
SURREL	Contribution of stored surface water to water flux	PADDY	mm d ⁻¹
SWIRTR	Switch to select calculation mode for relative transpiration ratio	WSTRESS	-
SWISLA	Switch to select method of imposed SLA calculation	ORYZA1	-
SWITGW	Groundwater switch	GWTAB, PADDY	-
SWITIR	Switch defining method of irrigation application	IRRIG	-
SWITKH	Hydraulic conductivity switch	PADDY	-
SWITPD	Puddled/nonpuddled soil switch	PADDY	-
SWITPF	Water retention curve switch	PADDY	-
SWITVP	Switch for calculation of percolation rate	PADDY	-
SWR	Year of simulation (switch into real number)	MODELS	y
TAV	Average daily temperature	ORYZA1, SUBCD, SUBGRN	°C
TAVD	Average daytime temperature	ORYZA1	°C
TBD	Base temperature for development	ORYZA1, SUBDD	°C
TBLV	Base temperature for juvenile leaf area growth	ORYZA1	°C
TCLSTR	Time coefficient for loss of stem reserves	ORYZA1	d ⁻¹
TCNTRF	Time coefficient for N translocation to grains	NCROP	d
TCOR	Temperature increase (e.g., as used in climate change study)	ORYZA1	°C
TD	Hourly temperature	SUBDD	°C
TDRW	Total aboveground and belowground dry biomass	ORYZA1	kg ha ⁻¹
TEFF	Factor accounting for effect of temperature on respiration	ORYZA1	-
TERMNL	Flag to indicate if simulation is to stop	MODELS, NCROP, ORYZA1, SUCBC	-
TEST	Difference between simulated and user-supplied SLA	SUBLAI2	ha leaf kg ⁻¹ leaf
TESTL	Logical variable to indicate whether the difference between simulated and imposed SLA is smaller than TESTSET	SUBLAI2	-
TESTSET	Maximum difference between simulated and user-supplied SLA	SUBLAI2	ha leaf kg ⁻¹ leaf

Variable	Description	Used in subroutine	Units
TFERT	Average daily maximum temperature during flowering	SUBGRN	°C
TIME	Time of simulation	Many subroutines	d
TINCR	Temperature increase because of leaf rolling	SUBGRN	°C
TINY	Parameter with very small value (to avoid division by 0)	PADDY, WSTRESS	-
TKL	Array of thickness of soil layers, per soil layer	GW TAB, MODELS, PADDY, SHRINK, WSTRESS	m
TKLP	Array of thickness of puddled soil layers, per layer	PADDY	m
TKLT	Thickness of combined soil layers	MODELS, ORYZA1, PADDY	m
TM	Mean daily temperature	SUBDD	°C
TMAX	Daily maximum temperature	ORYZA1, SUBDD, SUBGRN	°C
TMCTB	Table for temperature increase (e.g. as climate change study)	ORYZA1	d, °C
TMD	Maximum temperature for development	ORYZA1, SUBDD	°C
TMDA	Average daily temperature	ET, MODELS	°C
TMIN	Daily minimum temperature	ORYZA1, SUBDD	°C
TMMN	Daily minimum temperature	MODELS, ORYZA1	°C
TMMX	Daily maximum temperature	MODELS, ORYZA1	°C
TMPCOV	Temperature increase caused by greenhouse use (over seedbed)	ORYZA1	°C
TMPR1	Intermediate variable	SGPL, SRDPRF, SSKYC	-
TMPSB	Temperature increase caused by greenhouse use (over seedbed)	ORYZA1	°C
TNASS	Total net CO ₂ assimilation	ORYZA1	kg CO ₂ ha ⁻¹
TNM	Intermediate variable for numerical integration	SGPC2	-
TNSOIL	Daily amount of N available for uptake from soil	MODELS, NCROP	kg N ha ⁻¹ d ⁻¹
TOD	Optimum temperature for development	ORYZA1, SUBDD	°C
TOTPOR	Array of total porosity, per soil layer	PADDY, SHRINK	m ³ m ⁻³
TRC	Potential transpiration rate of crop with given LAI	ET, MODELS, WSTRESS	mm d ⁻¹
TREF	Reference temperature	ORYZA1	°C
TRR	Array of relative transpiration ratios, per soil layer	WSTRESS	mm d ⁻¹
TRRM	Potential transpiration rate of crop with given LAI, per unit root length	WSTRESS	mm d ⁻¹ m ⁻¹
TRW	Actual transpiration rate of crop with given LAI	MODELS, PADDY, WNOSTRESS, WSTRESS	mm d ⁻¹
TRWC	Cumulative actual transpiration, from main field	PADDY	mm
TRWCU	Cumulative actual transpiration since start of simulation	MODELS, PADDY	mm
TRWL	Array of actual water withdrawal by transpiration, per soil layer	BACKFL, DOWNFL, MODELS, PADDY, WNOSTRESS, WSTRESS	mm d ⁻¹
TS	Temperature sum for phenological development	ORYZA1, PHENOL	°Cd
TSHCKD	Transplanting shock for phenological development	ORYZA1, PHENOL	°Cd
TSHCKL	Transplanting shock for leaf area development	ORYZA1, SUBLAI2	°Cd
TSLV	Temperature sum for leaf area development	ORYZA1, SUBLAI2	°Cd
TSLVTR	Temperature sum for leaf area development at transplanting	SUBLAI2	°Cd
TSTR	Temperature sum for phenological development at transplanting	PHENOL	°Cd
TT	Daily increment in heat units	SUBDD	°Cd d ⁻¹
ULDL	Upper limit of drought-induced dead leaves	WSTRESS	pF
ULLE	Upper limit of leaf expansion	WSTRESS	pF
ULLS	Upper limit of leaf rolling	WSTRESS	pF
ULRT	Upper limit of relative transpiration	WSTRESS	pF

Variable	Description	Used in subroutine	Units
UPRICU	Cumulative capillary rise, since start of simulation	PADDY	mm
VGA	van Genuchten alpha parameter	PADDY	cm ⁻¹
VGL	van Genuchten lambda parameter	PADDY	-
VGN	van Genuchten n parameter	PADDY	-
VGR	van Genuchten residual water content	PADDY	-
VL	Array of thickness of soil layers after shrinkage, per soil layer	PADDY, SHRINK	mm
VP	Early morning vapor pressure	ET, MODELS	kPa
WAG	Total aboveground green dry matter	ORYZA1	kg DM ha ⁻¹
WAGT	Total aboveground dry matter	ORYZA1	kg DM ha ⁻¹
WCAAD	Array of soil water content at air dryness, per soil layer	PADDY	m ³ m ⁻³
WCAD	Array of soil water content at air dryness, per soil layer	MODELS, PADDY	m ³ m ⁻³
WCCR	Critical water content at which cracks break through soil layer	PADDY	m ³ m ⁻³
WCFC	Array of soil water content at field capacity, per soil layer	MODELS, PADDY	m ³ m ⁻³
WCL	Array of actual soil water content, per soil layer	PADDY, SHRINK	m ³ m ⁻³
WCLI	Array of initial water content of soil layer	PADDY	m ³ m ⁻³
WCLINT	Interpolation table for water content of soil layers	PADDY	-
WCLQT	Array of actual soil water content, per soil layer	ET, IRRIG, MODELS, WSTRESS	m ³ m ⁻³
WCMIN	Minimum soil water content in soil layer SLMIN at which to apply irrigation	IRRIG	m ³ m ⁻³
WCST	Array of soil water content at saturation, per soil layer	ET, MODELS, PADDY, SHRINK, WSTRESS	m ³ m ⁻³
WCSTRP	Array of saturated water content of ripened soil, per soil layer	PADDY, SHRINK	m ³ m ⁻³
WCUM	Amount of stored water in soil profile	PADDY	mm
WCUMCH	Rate of change in amount of stored soil water	PADDY	mm d ⁻¹
WCUMCO	Contribution of soil storage term to overall water balance	PADDY	mm
WCUMI	Initial amount of stored water in soil profile	PADDY	mm
WCWP	Array of soil water content at wilting point, per soil layer	MODELS, PADDY, WSTRESS	m ³ m ⁻³
WGRMX	Maximum individual grain weight	ORYZA1	kg grain ⁻¹
WL	Array of amount of water, per soil layer	BACKFL, DOWNFL, PADDY, SHRINK	mm
WLA	Array of total amount of water that can be extracted by roots in each soil layer	WSTRESS	mm
WL0	Depth of ponded water at soil surface	ET, IRRIG, MODELS, PADDY	mm
WL0CH	Rate of change of depth of ponded water	PADDY	mm d ⁻¹
WL0CNT	Number of days after disappearance of ponded water	IRRIG	d
WL0CO	Contribution of surface storage term (ponded water) to overall water balance	PADDY	mm
WL0DAY	Number of days after disappearance of ponded water at which to apply irrigation	IRRIG	d
WL0FCU	Cumulative amount of water stored at surface caused by groundwater	PADDY	mm
WL0FILL	Rate of change in ponded water depth when groundwater is at soil surface	PADDY	mm d ⁻¹
WL0I	Initial depth of ponded water	PADDY	mm
WL0MIN	Minimum ponded water depth at which to apply irrigation	IRRIG	mm
WL0MX	Maximum depth of ponded water (= bund height)	PADDY	mm
WLAD	Array of amount of water at air dryness, per soil layer	PADDY	mm
WLCH	Array of change in amount of water, per soil layer	PADDY	mm d ⁻¹
WLFC	Array of amount of water at field capacity, per soil layer	PADDY, DOWNFL	mm
WLFL	Array of water flux at boundaries of soil layer, per soil layer	GWTAB, PADDY	mm d ⁻¹

Variable	Description	Used in subroutine	Units
WLLW	Array of amount of water, per soil layer	SHRINK	mm
WLST	Array of amount of water at saturation, per soil layer	BACKFL, PADDY, SHRINK	mm
WLSTRP	Array of water amount at saturation of ripened soil, per soil layer	SHRINK	mm
WLW	Dry weight of leaves	ORYZA1	kg ha ⁻¹
WLVD	Dry weight of dead leaves	ORYZA1	kg ha ⁻¹
WLVG	Dry weight of green leaves	MODELS, NCROP, ORYZA1, SUBLAI2	kg ha ⁻¹
WLVGEXP	Value of WLVG at end of exponential growth phase after transplanting	SUBLAI2	kg ha ⁻¹
WLVGEXS	Value of WLVG at end of exponential growth phase in seedbed	SUBLAI2	kg ha ⁻¹
WLVGI	Initial dry weight of leaves	ORYZA1	kg ha ⁻¹
WLVGIT	Temporary storage variable of WLVG	ORYZA1	kg ha ⁻¹
WN	Average wind speed	ET, MODELS	m s ⁻¹
WRR	Dry weight of rough rice (final yield)	ORYZA1	kg ha ⁻¹
WRR14	Dry weight of rough rice (14% moisture)	ORYZA1	kg ha ⁻¹
WRT	Dry weight of roots	ORYZA1	kg ha ⁻¹
WRTI	Initial dry weight of roots	ORYZA1	kg ha ⁻¹
WSO	Dry weight of storage organs	MODELS, NCROP, ORYZA1	kg ha ⁻¹
WSOI	Initial dry weight of storage organs	ORYZA1	kg ha ⁻¹
WST	Dry weight of stems	MODELS, NCROP, ORYZA1	kg ha ⁻¹
WSTAT	Status code from weather system	MODELS	-
WSTI	Initial dry weight of stems	ORYZA1	kg ha ⁻¹
WSTR	Dry weight of stem reserves	ORYZA1	kg ha ⁻¹
WSTS	Dry weight of structural stems	ORYZA1	kg ha ⁻¹
WTRTER	Flag whether weather can be used by model	MODELS	-
WUSED	Flag indicating which weather data are required in model	MODELS	-
X	Intermediate variable for numerical integration	SGPC2	-
X	Counter for number of days that the difference between simulated and imposed SLA is larger than TESTSET	SUBLAI2	d
XFERT	Net fertilizer N rate that can be taken up by crop	NSOIL	kg N ha ⁻¹ d ⁻¹
xGAI	Total leaf area index	GPPARGET	ha leaf ha ⁻¹ soil
xGAID	Leaf area index above point of calculation	GPPARGET	ha leaf ha ⁻¹ soil
xAmaxIn	Uncorrected assimilation rate at light saturation	GPPARGET	kg CO ₂ ha ⁻¹ leaf h ⁻¹
xAmaxOut	Corrected assimilation rate at light saturation	GPPARGET	kg CO ₂ ha ⁻¹ leaf h ⁻¹
xEffIn	Uncorrected initial light-use efficiency	GPPARGET	(kg CO ₂ ha ⁻¹ leaf h ⁻¹)(W m ⁻² leaf) ⁻¹
xEffOut	Corrected initial light-use efficiency	GPPARGET	(kg CO ₂ ha ⁻¹ leaf h ⁻¹)(W m ⁻² leaf) ⁻¹
YEAR	Year of simulation	MODELS	y
ZL	Array of depth of top of soil layers, per soil layer	PADDY	cm
ZLL	Summed root depths of preceding soil layers	GWTAB, WSTRESS	m
ZRT	Root length or rooting depth	MODELS, ORYZA1, WSTRESS	m
ZRTI	Initial root length/depth at emergence	ORYZA1	m
ZRTL	Array of root length in a soil layer, per soil layer	WSTRESS	m
ZRTM	Maximum root length/depth	ORYZA1	m
ZRTMCD	Maximum root length/depth as crop characteristic under drought	ORYZA1	m

Variable	Description	Used in subroutine	Units
ZRTMCW	Maximum root length/depth as crop characteristic without drought	ORYZA1	m
ZRTMS	Maximum depth that roots can penetrate into soil	MODELS, ORYZA1, PADDY	m
ZRTTR	Root length/depth at transplanting	ORYZA1	m
ZW	Depth of groundwater table below soil surface	GWTAB, PADDY	cm
ZWPREV	Depth of groundwater table below soil surface of previous day	GWTAB	cm
ZWA	Depth that groundwater table recedes in case of no recharge	PADDY	cm
ZWB	Sensitivity factor of recharge of groundwater table	PADDY	-
ZWL	Difference between summed root depths of previous soil layers (ZLL) and groundwater depth at previous day (ZWPREV)	GWTAB	cm
ZWPREV	Groundwater table depth of previous day	PADDY	cm
ZWTB	Table with groundwater table depth as function of day number	PADDY	d, m
ZWTBI	Initial depth of groundwater table below soil surface	PADDY	cm
ZZA	Intermediate variable	SASTRO	-
ZZCOS	Cosine of ZZA	SASTRO	-
ZZSIN	Sine of ZZA	SASTRO	-

Common blocks

COMMON_GWT.INC: Common block groundwater table parameters	PADDY	-
COMMON_NUCHT.INC: Common block van Genuchten parameters	PADDY	-
COMMON_HYDCON.INC: Common block hydrological parameters	PADDY	-
COMMON_POWER.INC: Common block power function parameters	PADDY	-
COMMON_SWIT.INC: Common block hydraulic conductivity	PADDY	-

Subroutines and functions

Name	Description	Called in subroutine
BACKFL	Subroutine to calculate backflow of water	PADDY
DOWNFL	Subroutine to calculate downflow of water	PADDY
DTFSECMP	Function to determine crop emergence	MODELS
ET	Subroutine to calculate potential evaporation and transpiration	MODELS
GETOBS	Function to retrieve observed values from data file	ORYZA1, PADDY
GPPARGET	Subroutine to calculate corrected assimilation rate at light saturation and initial light-use efficiency	SGPL
GPPARSET	Subroutine to store variables in common block	ORYZA1
GWTAB	Subroutine to calculate the groundwater table depth	PADDY
INQOBS	Function to query for the presence of observed variables	ORYZA1, PADDY
IRRIG	Subroutine to calculate daily irrigation amounts	MODELS
INSW	Function to select variable value	ORYZA1, PADDY
INTGR2	Function to do integration	NNOSTRESS, ORYZA1, PADDY
INTGRL	Function to do integration	NCROP, NSOIL, ORYZA1, PADDY
LIMIT	Function to limit variable value to minimum/maximum	NCROP, WSTRESS
LINT2	Function for linear interpolation	Many subroutines
MODELS	Subroutine, interface between FSE subroutine and simulation models that make up the model ORYZA2000	ORYZA2000
NCROP	Subroutine to calculate the N dynamics in crop and the nitrogen-stress factors	MODELS

Name	Description	Called in subroutine
NNOSTRESS	Subroutine to set nitrogen-stress factors under conditions of potential production	MODELS
NOTNUL	Function to avoid division by 0	ORYZA1, NCROP, WSTRESS
NSOIL	Subroutine to calculate the N supply from soil	MODELS
ORYZA1	Crop growth module of ORYZA2000 model	MODELS
PADDY	Subroutine to calculate the soil water content and soil-water tension (soil-water balance)	MODELS
PHENOL	Subroutine to determine phenology of crop	ORYZA1
SASTRO	Subroutine to compute solar constant, daylength, and extraterrestrial radiation	SGPCDT, SETPTD
SATFLX	Subroutine to calculate percolation rate	PADDY
SETMKD	Subroutine to calculate Makkink evapotranspiration	ET
SETPMD	Subroutine to calculate Penman evapotranspiration	ET
SETPTD	Subroutine to calculate Priestley-Taylor evapotranspiration	ET
SGPC1	Subroutine to compute instantaneous canopy CO ₂ assimilation and instantaneous absorbed photosynthetically active radiation	SGPCDT
SGPC2	Subroutine to compute instantaneous canopy CO ₂ assimilation and instantaneous absorbed photosynthetically active radiation	SGPCDT
SGPCDT	Subroutine to calculate daily total gross assimilation	ORYZA1
SGPL	Subroutine to calculate assimilation at a single depth in canopy	SGPC2, SGPC1
SHRINK	Subroutine to calculate shrinkage of puddled soil	PADDY
SRDPRF	Subroutine to calculate absorbed flux of radiation for shaded leaves, direct flux absorbed by leaves, and fraction of sunlit leaf area	SGPL
SSKYC	Subroutine to estimate solar inclination and fluxes of diffuse and direct radiation at a particular time of day	SGPCDT
SUBCBC	Subroutine for carbon balance check	ORYZA1
SUBCD	Subroutine to calculate number of cold days	ORYZA1
SUBDD	Subroutine to calculate daily amounts of heat units	ORYZA1
SUBGRN	Subroutine to calculate grain growth rate and grain formation rate	ORYZA1
SUBLAI2	Subroutine to calculate leaf area index	ORYZA1
SUBNBC	Subroutine for nitrogen balance check	NCROP
SUBSL2	Subroutine to calculate capillary rise	PADDY
SUERR	Subroutine to check if a variable falls within a specified domain	PADDY
SUWCHK	Subroutine to check soil-water balance	PADDY
SUWCMS2	Subroutine to calculate soil water content from soil-water tension	PADDY
WNOSTRESS	Subroutine to set actual transpiration and drought-stress factors under potential production situations	MODELS
WSTRESS	Subroutine to calculate actual crop transpiration and drought-stress factors	MODELS

The variables of the following subroutines are not included in the variable list, and readers are referred to the indicated references for explanation of the subroutines:

FSE: van Kraalingen (1995)

SATFLX: Wopereis et al (1996a)

SETPTD, SETPMD, SETMKD, SVPS1: van Kraalingen and Stol (1997)

SUBSL2, SUERR, SUMSKM2, SUWCHK, SUWCMS2: Penning de Vries et al (1989) and ten Berge et al (1992)

Index

- Albedo, 81
- Alternate wetting and drying, 118
- AMAX, 46–48
- Ångström formula, 18
- Ångström parameters, 18, 156, 186
- Applications, 203
- Assimilation
 - instantaneous rate, 45
 - of a single leaf, 46–48
 - of the crop (gross), 38
 - of the crop (net), 72
- Atmospheric transmission, 44

- BACKFL, 128
- Bund height, 178

- Calibration, 196
- Capillary rise, 116, 134
- Carbon balance check, 73
- Carbon balance parameters, 174
- CD-ROM, 191
- Cluster factor, 51
- CNTR, 156
- CO₂ concentration, 48, 168
- Compaq Visual FORTRAN, 191
- Cooling degree-day, 16
- Cracks (in soil), 118, 122, 139
- CRACKS, 120
- Critical tension for crack
 - development, 122, 179
- Crop stage (CROPSTA), 16

- Daylength, 43
- DELTA, 5, 155
- Development phase, 34
 - (grain filling, panicle initiation, photoperiod-sensitive, vegetative)
- Development rate, 33–34
- Development rate parameters, 165, 198
- Development stage, 30–31
- Dilution parameter, 57, 105
- DOY, 5
- DOWNFL, 127
- Drainage to groundwater, 133
- DRATES, 196
- Drought stress, 84, 200
- Drought stress factor on
 - flowering time, 36, 88
 - leaf death, 71, 90
 - leaf expansion, 69, 88
 - leaf rolling, 37, 88
 - partitioning, 52, 89
 - photosynthesis, 38, 91, 94
 - rooting depth, 75, 89
 - spikelet sterility, 62, 88
 - transpiration, 91
- Drought stress parameters, 175
- Drying power term, 80

- Emergence, 30, 157
- End rerun (endrun), 150, 188
- ESTAB, 11, 157
- Establishment, 157
- ET, 79
- ETMOD, 11, 154
- Evaporation, 79, 117
 - actual, 132
 - potential, 79, 84
- Evapotranspiration module, 11, 154
- Evapotranspiration, reference, 80
- Experimental conditions, 153
- Exponential growth phase, 65, 66, 69
- Extinction coefficient for
 - N distribution, 37
 - photosynthetically active radiation, 50
 - visible light, 37, 168

FAOF, 83
 FATALERR, 20
 Fertilizer N application, 111, 160
 Fertilizer N recovery, 111, 160
 File
 control, 150
 crop, 164
 experimental, 153
 model log, 189
 output, 188
 output (OP.DAT), 189
 output (RES.BIN), 189, 194, 195
 rerun, 187
 soil, 177
 weather, 185
 weather log, 189
 FINTIM, 155
 Flowering, 30, 34
 Flowering delay, 36, 89
 Forcing function on
 leaf area index, 164
 N content leaves, 164
 soil water content, 184
 Forcing switch, 74, 138
 FORTRAN Simulation
 Environment (FSE), 3
 Fraction
 diffuse radiation, 44
 photosynthetically active
 radiation, 168
 stem reserves, 174, 198

 Gaussian integration, 41, 45, 47
 van Genuchten parameters, 130,
 181–182
 GETOBS, 19
 GPPARGET, 47–48
 GPPARSET, 38
 Grain formation, 58–63
 Grain weight, 74
 Green area index, 37
 Groundwater table depth, 121, 123,
 136, 179

 Groundwater switch, 179
 Growth parameters, 166, 171
 Growth rate of
 crop (gross) 56
 crop (net) 57
 crop organs, 57
 grains, 53, 58
 leaf area index, 63–70
 roots, 174
 stem reserves, 58
 structural stem material, 58
 GWTAB, 123, 137

 Heat unit, 32
 Hydraulic conductivity, 127, 130,
 182

 IDOY, 5
 Initial light-use efficiency, 37, 47,
 169
 INQOBS, 20
 Installation of ORYZA2000, 191,
 194
 Integration, 3
 INTGR2, 20
 INTGRL, 20
 IRRIG, 143
 Irrigation, 143, 158
 amount, 145, 159
 switch, 158
 threshold values, 144, 146, 159
 ISTN, 156
 ITASK, 4
 IYEAR, 155, 156

 Leaf area index, 63–70
 Leaf expansion, 65, 88
 Leaf rolling 37, 62, 87
 LIMIT, 20
 Linear growth phase, 67
 LINT, 20
 LINT2, 20
 Loss rate of leaves, 53, 173, 198

Loss rate of stem reserves, 54
 Lowland, 115
 Maintenance
 parameters, 170
 requirements, 55, 170
 respiration, 54
 Makkink, 80, 154
 Management parameters, 157
 Maximum
 groundwater depth, 179
 individual grain weight, 174
 N content in leaves, 99, 177
 N content in storage organs, 100, 176
 N demand of leaves, 99
 N demand of stems, 99
 N demand of storage organs, 100
 N uptake rate, 103, 176
 root depth, 75, 174, 178
 temperature, 18, 29, 186
 translocatable amount of N, 102
 Measured variables
 crop, 161–163, 197
 soil water, 183–184
 Minimum
 groundwater depth, 179
 N content in leaves, 99, 177
 N content in storage organs, 176
 N demand of storage organs, 100
 temperature, 18, 29, 186
 MODELS, 6

 Nitrogen
 amount in crop organs, 106
 balance check, 110
 content of leaves, 38, 48, 98, 107, 170, 198
 content of stems, 99, 107
 content of storage organs, 107
 demand, 99, 104
 effect on photosynthesis, 48, 107
 flow to crop organs, 105
 indigenous soil supply, 111
 limitations, 1, 7, 24, 97, 154
 mineralization, 160
 parameters, 159, 175
 profile in canopy, 169
 residual fraction in leaves, 176
 stress factor for leaf growth, 66, 107
 stress factor for leaf loss, 53, 104
 translocation, 102
 uptake, 103–104
 NCROP, 97
 Newton-Raphson procedure, 130
 NITROENV, 7, 97, 154
 NNOSTRESS, 112
 NOTNUL, 20
 NSOIL, 110

 Observed variables, (see Measured variables)
 OP_OBS, 5, 19
 OPSTOR, 21
 ORYZA1, 23
 OUTDAT, 21

 PADDY, 118
 Panicle initiation, 30, 34
 PARAM, 196
 Parameter estimation, 199
 Partitioning coefficients and tables, 52–53, 172–173, 198
 Penman, 80, 154
 Percolation, 117, 125–126, 129, 180
 pF, 85, 118
 PHENOL, 33
 Phenological development, 30–31
 Photoperiod, 33–34
 Photosynthesis, (see Assimilation)
 Photosynthesis parameters, 166–167
 Photosynthesis reduction, 38, 94
 Physiological maturity, 30
 Plow sole, 116–118

Power function, 130, 181–183
 Precipitation, (see Rain)
 Priestley-Taylor, 80, 154
 PRODENV, 7, 79, 115, 154
 Production situation
 potential, 1, 7, 23, 154
 nitrogen-limited, 1, 7, 24, 97, 154
 water-limited, 1, 7, 24, 79, 115, 154
 PUDDL, 120
 Puddling, 115

 Q_{10} , 55

 Radiation, 18, 186
 absorbed, 38, 45, 51
 diffuse, 44, 50, 51
 direct, 44, 51
 direct component, 50, 51
 extraterrestrial, 43
 photosynthetically active, 38, 45, 168
 short-wave, 44, 169
 term, 80
 visible, 44
 Rain, 18, 186
 Rate-state concept, 3
 RDAREA, 21
 RDINIT, 21
 RDSCHA, 21
 RDSINT, 21
 RDSREA, 21
 Read-only, 191, 194
 Reflection coefficient of
 canopy, 50
 soil, 81
 Reinitialization switch, 183
 Relative death rate of leaves, 53, 173
 Relative leaf area growth rate, 65, 108, 167, 198
 Respiration
 growth, 56, 170
 maintenance, 54
 requirements, 170
 Reruns, 187
 Ripening of soil, 118
 RIWCLI, 122, 183
 Root
 depth, 75
 length growth rate, 75
 length in each soil layer, 86
 parameters, 174
 Rough rice, 74
 RUNMODE, 11, 153
 Running ORYZA2000, 191, 194
 Runoff, 116, 126

 SASTRO, 41
 SATFLX, 126, 130
 Saturated hydraulic conductivity, 127, 182
 SAWAH, 131
 Scattering coefficient of leaves, 50, 168
 Seedbed duration, 116, 157
 Seepage, 117, 180
 Senescence, 71
 SETMKD, 80
 SETPMD, 80
 SETPTD, 80
 SGPC1, 45
 SGPCDT, 39
 SGPL, 46
 SHRINK, 123, 139
 Shrinkage, 118, 122, 139
 Sink limitations, 53
 Soil
 conductivity, 181
 layer thickness, 178
 number of layers, 178
 number of puddled layers, 121, 178
 porosity, 139–140
 Soil-water
 balance, 115

balance check, 141
 content, 135, 183–184
 content at air dryness, 135, 138, 182
 content at field capacity, 135, 182
 content at saturation, 135, 138, 181
 content at saturation after ripening, 179
 content at wilting point, 135, 182
 potential, 85, 118
 retention characteristics, 181–182
 tension, 85, 118, 183–184
 uptake compensation, 93–94
 Solar constant, 43
 Specific green stem area, 37, 167
 Specific leaf area, 63, 67, 167, 198
 Specific leaf N, 48
 Spikelet formation 58, 60, 174
 Spikelet sterility, 60–63, 87
 SRDPRF, 49
 SSKYC, 43
 Start rerun (strun), 150, 188
 Stem area index, 37
 STINFO, 5, 18
 STTIME, 155
 SUBCD, 32
 SUBDD, 30, 64
 SUBGRN, 58
 SUBLAI2, 64
 SUBLS2, 135
 SUERR, 143
 SUMSK2, 143
 Sunshine hours, 18, 186
 SUWCHK, 143
 SUWCMS2, 123, 135
 SWITGW, 121, 179
 SWITIR, 144, 159
 SWITKH, 122, 131, 181
 SWITPD, 121, 178
 SWITPF, 122, 181
 SWITVP 121, 180
 Syntax rules data files, 149
 Temperature
 adjustment table, 156
 average (daily), 29
 base, 31
 changes, 29
 correction factor, 28
 hourly, 32
 maximum, 18, 29, 186
 minimum, 18, 29, 186
 optimum, 31
 sum, 34
 Terminating a simulation run, 76
 TIME, 5
 Time step of integration, (see DELT)
 TIMER2, 5
 Transpiration, 116
 actual, 91–92
 potential, 79
 ratio, 38, 91
 Transplanting, 11, 116, 157
 Transplanting shock, 34, 68, 166–167
 TTSELECT, 194–195
 TTUTIL, 19

 Validity domain, 200
 Vapor pressure, 18, 186

 Water limitation, 1, 7, 24, 79, 115, 154
 WCLINT, 139, 185
 WEATHER, 18
 Weather station, 18, 186–187
 WEATHR, 5, 18
 Wind- and humidity-driven term, 80
 Wind function, 82
 Wind speed, 18, 186
 WNOSTRESS, 95
 WSTAT, 12
 WSTRESS, 84
 WTRDIR, 156
 WUSED, 9

ISBN 971-22-0171-6



9 789712 201714