



**AgEcon** SEARCH  
RESEARCH IN AGRICULTURAL & APPLIED ECONOMICS

*The World's Largest Open Access Agricultural & Applied Economics Digital Library*

**This document is discoverable and free to researchers across the globe due to the work of AgEcon Search.**

**Help ensure our sustainability.**

Give to AgEcon Search

AgEcon Search

<http://ageconsearch.umn.edu>

[aesearch@umn.edu](mailto:aesearch@umn.edu)

*Papers downloaded from **AgEcon Search** may be used for non-commercial purposes and personal study only. No other use, including posting to another Internet site, is permitted without permission from the copyright owner (not AgEcon Search), or as allowed under the provisions of Fair Use, U.S. Copyright Act, Title 17 U.S.C.*



# Promoting Entrepreneurial Behavior among Agricultural Students: A Two-Step Approach to Structural Equation Modeling

Nematollah Shiri<sup>1</sup>, Ali Asghar Mirakzadeh<sup>2\*</sup> and Kiumars Zarafshani<sup>3</sup>

Received: 07 April 2016,  
Accepted: 01 January 2017

## Abstract

Increasing rate of unemployment among the graduates of Iranian higher agricultural education system has been developed into one of the major socio-economic problems of the nation. Entrepreneurship is one of the most important factors contributing to economic and social development, that is, it is a main driver for employment creation. As such, many policy initiatives in Iran attempt to pull agricultural students toward an entrepreneurial career choice. In this regard, considering the importance of entrepreneurship, and applying Ajzen's (1991) theory of planned behavior, the present study was conducted to investigate the factors affecting entrepreneurial behavior of agricultural students in Razi University. The population of this study consisted of all senior agricultural students of Razi University in Iran (N=300), 169 of whom were selected as the sample using the proportional stratified sampling method. Data were analyzed by SPSS and AMOS version 23 software in two phases of descriptive and inferential statistics. Results of structural equation modeling revealed that personal attitude toward entrepreneurship, perceived behavioral control, and subjective norm were the main predictors of entrepreneurial intention ( $R^2=0.46$ ) and behavior ( $R^2=0.45$ ) among agricultural students. The findings of this study can have practical implications concerning the promotion of entrepreneurial intention and behavior among agricultural students for higher agricultural education managers, planners, and educators.

**Keywords:**  
agricultural students, entrepreneurship, entrepreneurial intention, unemployment

<sup>1</sup> Ph.D. Candidate, Department of Agricultural Extension and Education, Razi University, Kermanshah, Iran

<sup>2</sup> Assistant Professor, Department of Agricultural Extension and Education, Razi University, Kermanshah, Iran

<sup>3</sup> Associate Professor, Department of Agricultural Extension and Education, Razi University, Kermanshah, Iran

\* Corresponding author's email: [mirakzadeh@razi.ac.ir](mailto:mirakzadeh@razi.ac.ir)

## INTRODUCTION

The unemployment crisis in many countries is considered a major problem, even in advanced industrial countries (Shiri et al., 2012). This problem can be considered as an economic illness in developing countries, especially in Iran, which faces severe conditions (Papzan et al., 2013). Each year, 800000 jobseekers enter the labor market, which constitutes one of the main challenges in social-economic development in Iran. In fact, unemployment crisis is a threat to the whole society, especially unemployment among higher education graduates will have the non-compensation consequences in social, economic and political dimension. As shown by statistics, every year 270000 higher education graduates enter the job market; however, the market capacity does not fulfill their employment needs (Shiri et al., 2012). In this regards, significant increase in unemployment among educated groups, in particular, graduates of higher agricultural education systems in Iran, has become one of the problems in today's society (Ghasemi et al., 2009). Hence, increasing rate of unemployment among the graduates of agricultural colleges has been developed into one of the major socio-economic problems of the nation.

One strategy that has helped many developed and developing countries to overcome the problem of unemployment, has been the development of entrepreneurship (Papzan et al., 2013). Entrepreneurship relates to the capability for exploiting successfully innovative ideas in a commercially competitive market. Entrepreneurship is generally considered a source of flexibility and innovation, a creator of jobs for the economy, and an interesting opportunity for individual career development (Onstenk, 2003). Both within and outside the European community, policies on education and life-long learning emphasize the importance of stimulating Entrepreneurial Behavior (EB) (European Community, 1999). Integrating entrepreneurship development in higher education is viewed as an effective way to promoting entrepreneurial behavior at the economic market and the labour market (Dam et al., 2010).

The entrepreneurship literature has made significant efforts to explain how and why new

ventures originate and, as a result, made valuable theoretical and empirical contributions to our understanding of the early stage of the entrepreneurial process. The creation of one's own venture involves careful planning and thinking on the part of the individual, which makes entrepreneurship a deliberate and planned intentional behavior (Bird, 1988).

Consequently applicable for intention models (Krueger & Carsrud, 1993), across a wide range of different behaviors, behavioural intentions have been identified as the most immediate predictor of actual behaviour (Ajzen, 1991). Accordingly, given the social and economic benefits of promoting entrepreneurship in society, it has become the dominant theme of more recent research in the entrepreneurial intentions and behavior (Carree & Tharik, 2006). This has stimulated public institutions, educational and academic to investigate the factors affecting entrepreneurial intentions and behavior (Leroy et al., 2009).

In this regard, over the past four decades, great interest has been given to understand the factors affecting the intentions and behavior of people to engage in entrepreneurial activity (Learned, 1992; Zhao et al., 2010). Moreover, in this period, renewed attention is given to the role of intentions in the process of entrepreneurship (Bird, 1988; Krueger & Carsrud, 1993). Especially, intention-based models examine the intent, but not the timing, of venture creation (Krueger, 2000). It may be a relatively long or short time after intent develops before a new venture opportunity is even identified. Nonetheless, intention-based models contend that venture creation must be preceded by the development of intentions to create a new venture, and that by understanding intentions we can better predict entrepreneurial behavior (Shook et al., 2003). Several scholars emphasize the importance of entrepreneurial intentions as a first step towards entrepreneurial behavior (i.e., starting a business) (Bird, 1988; Krueger & Carsrud, 1993). In fact, prior research suggests that intentions are the single best predictor for planned behaviours, such as starting a business (Bagozzi et al., 1989).

In this regards, a significant body of literature on entrepreneurship highlights the importance

of studying cognitive factors, such as entrepreneurial motivation (e.g., attitudes, perceptions) and intention, in order to provide insights into the complex process of entrepreneurial behavior (Autio et al., 2001; Krueger, 2000; Peterman & Kennedy, 2003; Tkachev & Kolvereid, 1999). Such a cognitive perspective is valuable because it represents an attempt to understand the formation of new ventures and the underlying structures and processes (Henry et al., 2005). While there have been developments in this field, there is a lack of research across agricultural fields in Asian countries. In the other word, up until now, few attempts have been made to investigate entrepreneurial intentions, behavior, attitudes, and motivations of students in developing countries (Nabi & Linan, 2011).

According to most researchers, the Theory of Planned Behavior (TPB) (Ajzen, 1991), can offer a valid framework in order to analyze and measure the impact of Personal Attitude (PA), Perceived Behavioral Control (PBC) and Subjective Norm (SN) on entrepreneurial intentions and behavior (Armitage & Conner, 2001). In particular, there is limited available research on the application of the TPB to non-western cultures including more collectivist cultures like that of Iran. In addition to knowing very little about Entrepreneurial Intentions (EI) for developing and/or non-western countries, we also know very little about the contributions of cultural values at the level of the individual to the motivational antecedents of entrepreneurial intention and behavior (Karimi, 2014).

Therefore, in this study, the theory of planned behavior is used as a tool that examines factors affecting entrepreneurial intention and behavior. In this regard, this study can be effective both to contribute to the literature and can be associated with the theory of planned behavior. According to this and considering the importance of entrepreneurship, by applying Ajzen's (1991) theory of planned behavior, the present study was conducted to investigate the factors affecting entrepreneurial behavior of agricultural students in Razi University, Iran.

Intentionality and forethought are acknowledged to be core features of human beings

(Bandura, 2001). Intention constitutes a representation of the direction of future action. It affects individuals' choices as well as directs and maintains behavior. Research to date in areas as diverse as health-related behavior, voting behavior, spare-time activity, or job seeking demonstrates that intention is a strong predictor of behavior (Moriano et al., 2012).

Entrepreneurial intention is defined as the conscious state of mind that precedes action and directs attention toward a goal such as starting a new business (Bird, 1988; Krueger & Carsrud, 1993). Entrepreneurial intention can be defined as a conscious awareness and conviction by an individual that they intend to set up a new business venture and plans to do so in the future (Bird, 1988; Thompson, 2009). Entrepreneurial intention represents the commitment of individuals to start a new business (Krueger & Carsrud, 1993). The process of starting a new firm can thus be regarded as voluntary with conscious intentionality. More importantly, intention has been considered as the single most powerful predictor of entrepreneurial behaviors (Autio et al., 2001; Krueger et al., 2000), and also an important dependent variable in its own right (Thompson, 2009). Forming an intention to develop an entrepreneurial career is the first step in the often long process of venture creation (Gartner et al., 1994).

Several models aim to explain entrepreneurial intentions such as the entrepreneurial event model of Shapero (1982), the model of implementing entrepreneurial ideas (Bird, 1988) or maximization of the expected utility (Douglas & Shepherd, 2002). Although these models represent a step forward in entrepreneurial behavior research, they have not been as influential as the TPB (Autio et al., 2001; Krueger, 2000; Tkachev & Kolvereid, 1999; Van-Gelderen et al., 2008). Unlike other models, the TPB offers a coherent and generally applicable theoretical framework, which enables us to understand and predict entrepreneurial intention by taking into account not only personal but also social factors (Krueger, 2000). As such, personal history and characteristics and skills can predispose individuals to entrepreneurial intentions as well as the social context (Moriano et al., 2012).



However, according to the TPB, only the three TPB components, that is, personal attitude toward behavior, subjective norms and perceived behavioural control predict behavioral intentions directly.

The attitude toward behavior within the TPB is defined as an individual's overall evaluation of behavior (Ajzen, 1991). Personal attitude toward becoming an entrepreneur refers to the extent of positive valuation about the start-up of a new venture (Linan et al., 2013). According to the TPB, the attitude toward behavior is determined by the total set of accessible behavioral beliefs linking the behavior to various outcomes and other attributes. In addition, the strength of each belief is weighted by the evaluation of the outcomes (Ajzen, 1991). Accordingly, two people may hold an equally strong belief that entrepreneurship involves facing new challenges, but one of them may view these challenges positively, while the other may consider them unpleasant. This two-element process of attitude formation allows us to explain why persons holding different beliefs may exhibit identical attitudes, and vice versa (Moriano et al., 2012).

The second component of the TPB is the subjective norm, which is defined as the individual's perception of the social pressures to engage (or not to engage) in entrepreneurial behavior (Ajzen, 1991). Subjective norm reflects the pressure and approval from significant others of becoming an entrepreneur, thus taking into account the individual's social context (Linan et al., 2013). The subjective norm consists of two components: normative beliefs and the motivation to comply with these beliefs (Ajzen & Fishbein, 1980). Normative beliefs concern the perceived probability that important referent individuals or groups will approve or reject a given behavior; they set the norm that specifies how the subject should behave. The second component, motivation to comply, reflects a person's willingness to conform to these norms, that is, to behave in keeping with the expectation of important referents. Depending on the social environment, these pressures can become a trigger or a barrier to the development of an entrepreneurial career.

The third TPB component, perceived behavioural control, refers to people's perceptions of their ability to perform a given behavior (Moriano et al., 2012). In the other word, Perceived behavioural control measures the perceived ease or difficulty of becoming an entrepreneur (Linan et al., 2013). Individuals usually choose to perform behaviours that they think they will be able to control and master (Moriano et al., 2012). This concept is therefore very similar to self-efficacy (Bandura, 1982). Both concepts concerned the perceived ability to perform behavior, for example, starting a new business (Moriano et al., 2012). The importance of this variable in the new-firm creation process resides in its predictive capacity, as it reflects the perception that the individual will be able to control that behavior (Ajzen, 2002).

As noted above, entrepreneurial intention has been considered as the single most powerful predictor of entrepreneurial behaviours (Autio et al., 2001; Krueger, 2000), and also an important dependent variable in its own right (Thompson, 2009). In the other words, the intention to perform a given behavior constitutes the central element of TPB (Ajzen, 1991), the stronger the intention to perform a given behavior, the greater the probability of its effective performance. Reviews of existing research show that intention accounts for approximately between 30% (Armitage & Conner, 2001) and 77% (Barani et al., 2011) of the variance in entrepreneurial behavior. Furthermore, past research shows that the individual TPB components (PA, SN and PBC) in turn together explain among 21% (Autio et al., 2001), 55% (Linan & Chen, 2009), 30% (Soliemani & Zarafshani, 2011) and 96% (Barani et al., 2011) of the variance in the entrepreneurial intention.

Research has generally provided support for the TPB in the context of entrepreneurial intention and behavior and confirmed the theory's predictive validity when using three motivational antecedents (e.g., Autio et al., 2001; Barani et al., 2011; Engle et al., 2010; Karimi et al., 2013; Karimi, 2014; Krueger, 2000; Linan & Chen, 2009; Iakovleva et al., 2011; Moriano et al., 2012; Papzan et al., 2013). The outcomes of the aforementioned studies nevertheless show

marked variation across situations and countries in the relative importance of the antecedents and the magnitude of their influences. Clear and significant effects of attitudes toward entrepreneurship and perceived behavioral control on the EI and EB of students have been documented for a variety of countries (e.g., Engle et al., 2010; Iakovleva et al., 2011; Moriano et al., 2012), including Iran (Barani et al., 2011; Soliemani and Zarafshani, 2011; Papzan et al., 2013; Karimi et al., 2013; Karimi, 2014). More specifically, our model suggests that PA and PBC should influence entrepreneurial intention and behavior. Yet, the case of SN is more intriguing and typically the weakest predictor of entrepreneurial intention. Studies have found a weak or

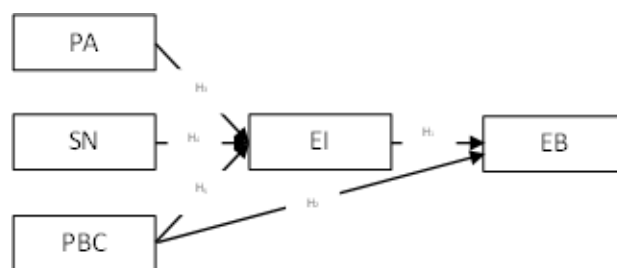

Figure 1. Theoretical Framework of Study

no direct effect between SN and entrepreneurial intention (Autio et al., 2001; Barani and Zarafshani, 2009; Krueger, 2000; Moriano et al., 2012; Soliemani & Zarafshani, 2011). The effects of subjective norms on the EI of students are less clear cut, however: Most studies show only small or non-significant direct prediction of EI.

Table 1  
Summary of Goodness of Fit Indices For the Measurement Model

Fit indices	X <sup>2</sup>	P	X <sup>2</sup> /df	GFI	CFI	TLI	IFI	RMSEA
Value in study	555.51	0.000	1.77	0.81	0.98	0.97	0.97	0.068
Suggest value	-	>0.05	<3	>0.80	>0.90	>0.90	>0.90	<0.08

Table 2  
Results of Confirmatory Factor Analysis For the Measurement Model

Constructs	Indictors	Standardized factor loading	t-value	CR	AVE
EB	EB1	0.85	-	0.900	0.566
	EB2	0.84	13.47**		
	EB3	0.83	13.23**		
	EB4	0.79	12.22**		
	EB5	0.65	9.31**		
	EB6	0.65	9.28**		
	EB7	0.62	8.69**		
EI	EI1	0.72	-	0.898	0.597
	EI2	0.73	12.03**		
	EI3	0.80	10.03**		
	EI4	0.86	10.70**		
	EI5	0.82	10.22**		
	EI6	0.69	8.64**		
PBC	PBC1	0.85	-	0.875	0.585
	PBC2	0.72	10.58**		
	PBC3	0.67	9.53**		
	PBC4	0.80	12.30**		
	PBC5	0.77	11.72**		
PA	PA1	0.81	-	0.903	0.653
	PA2	0.87	13.16**		
	PA3	0.76	10.93**		
	PA4	0.86	13.01**		
	PA5	0.73	10.37**		
SN	SN1	0.74	-	0.778	0.538
	SN2	0.76	8.40**		
	SN3	0.70	11.19**		

\*\*Factor loading issignificant at the <0.01 level

Table 3  
Means, SD and Correlations With Square Roots of the AVE

Constructs	Mean	SD	1	2	3	4	5
1- EB	4.15	1.46	<b>0.86<sup>a</sup></b>				
2- EI	4.32	1.65	0.70**	<b>0.88<sup>a</sup></b>			
3- PBC	4.44	1.45	0.75**	0.77**	<b>0.87<sup>a</sup></b>		
4- PA	4.59	1.47	0.53**	0.63**	0.75**	<b>0.91<sup>a</sup></b>	
5- SN	3.97	1.44	0.65**	0.67**	0.69**	0.70**	<b>0.79<sup>a</sup></b>

\*\*Correlation is significant at the <0.01 level

<sup>a</sup>The square roots of AVE estimates

For example, [Autio et al. \(2001\)](#) researching students in Scandinavian countries and the United States found PBC to be most closely associated with entrepreneurial intention, whereas subjective norm was not a significant predictor. In a study by [Moriano et al. \(2012\)](#), subjective norm significantly related to EI in only two out of six countries and only predicted EI marginally in Iran. Similarly, [Krueger \(2000\)](#) found that PA and PBC, but not subjective norm, were significantly correlated with students' entrepreneurial intention. In this regard, [Ajzen \(1991\)](#) has suggested that the three antecedents of TPB may not always play a role in the prediction of intention and behavior. These studies support [Ajzen's \(1991\)](#) assertion that all three antecedents are important, although they also show that their relative importance's as well as the magnitude of their effect are not the same in every situation and country. Thus, these findings suggest that all three of Ajzen's intention an-

tecedents should be included when examining EI and EB. Based on the theory of planned behaviour ([Ajzen, 1991](#)), the factors affecting entrepreneurial behavior of agricultural students in Razi University can be found in the following theoretical framework (Figure 1).

### MATERIALS AND METHODS

This study was quantitative in nature and applied in purpose. The statistical population of this study was consisted of all senior students were studying in agricultural field at Razi University (N=300). Based on Krejcie and Morgan (1970) sampling table and applying proportional stratified sampling method (based on field), 169 students were chosen for study. The main instrument of this research was a questionnaire, which consisted of six parts: (a) demographic characteristics (age and gender); (b) personal attitude toward entrepreneurship (5 item); (c) subjective norm (3 item); (d) perceived behav-

Table 4  
Summary of Goodness of Fit Indices For the Structural Model

Fit indices	X <sup>2</sup>	P	X <sup>2</sup> /df	GFI	CFI	TLI	IFI	RMSEA
Value in study	1.77	0.413	0.885	0.99	1.00	1.00	1.00	0.000
Suggest value	-	>0.05	<3	>0.80	>0.90	>0.90	>0.90	<0.08

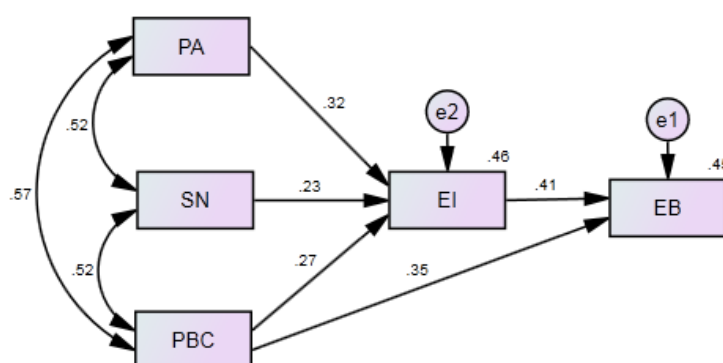

Figure 2. Path Model with Standardized Factor Loadings

Table 5  
Direct, Indirect, and Total Effects on Entrepreneurial Behavior

Determinant	Outcome	Direct effect	Indirect effect	Total effect
EI	EB	0.41**	-	0.41
PBC	EB	0.35**	0.11	0.46
PA	EB	-	0.13	0.13
SN	EB	-	0.10	0.10
PBC	EI	0.27**	-	0.27
PA	EI	0.32**	-	0.32
SN	EI	0.23**	-	0.23

\*\* significant at the <0.01 level

itorial control (5 item); (e) entrepreneurial intention (6 item); and (f) entrepreneurial behavior (7 item). In the b, c, d, e and f parts of the questionnaire we adapted the scale's Linan and Chen (2009). The validity of questionnaire was confirmed by the panel of experts, Average Variance Extracted (AVE) and discriminant validity and its reliability was confirmed by Cronbach's Alpha coefficient and composite reliability (Table 2). Data were analyzed by SPSSWin23 and AMOS23 software in two parts of descriptive and inferential statistics. Frequency, percent, mean and standard deviation used as descriptive statistics and correlation analysis, Confirmatory Factor Analysis (CFA) and path analysis were used as inferential statistics.

## RESULTS

According to the results agricultural students' age mean was 22.30 with a standard deviation of 1.37. Among the respondents, 96 (56.8%) were female and 73 (43.2%) were male.

Structural Equation Modeling (SEM) was used to test for the direct, indirect and mediating effects of the PA, PBC, SN and EI variables in the prediction of EB. According to Hair et al. (2010), it is appropriate to adopt a two-step approach for SEM: first, assessment of the measurement model; second, assessment of the structural model.

The results of confirmatory factor analysis showed the initial measurement model to provide an acceptable fit for the data ( $X^2=555.51$ ;  $X^2/df=1.77$ ;  $GFI=0.81$ ;  $TLI=0.97$ ;  $CFI=0.98$ ;  $IFI=0.97$ ;  $RMSEA=0.068$ ). Therefore, the measurement model provided a reasonable fit (Table 1). Thus, the hypothesized model with five factors was judged suitable for the SEM.

Convergent validity: A first condition for convergent validity is that the standardized factor loadings should all be significant (have a critical ratio ( $t\text{-value}>1.96$ ) with a value of more than 0.50 (Janssen et al., 2008). Results in Table 2, shows the t-value for the factor loadings to all exceed 8.40 ( $p<0.01$ ) and the factor loadings to all have values greater than 0.62. This shows good convergent validity for the constructs (PA, SN, PBC, EI and EB) of this study.

Construct Reliability (CR): For the composite or construct reliability to be adequate, a value of  $CR=0.70$  or higher is recommended (Nunnally & Bernstein, 1994). As shown in Table 2, all of the constructs had construct reliabilities which were greater than the recommended 0.70. The results also show the AVE estimate for all of the constructs to be above or close to the recommended threshold of 0.50 (Fornell & Larcker, 1981). This shows good composite or construct reliability for the constructs (PA, SN, PBC, EI and EB) of this study.

Discriminant validity: According to Fornell and Larcker (1981), if the square root of the AVE estimate for each construct is greater than the correlation between that and all of the other constructs in the model, then discriminant validity is demonstrated. As shown in table 3, the square root of each AVE is greater than its correlations with the other constructs. This means that the indicators have more in common with the construct that they are associated with the other constructs. Thus, discriminant validity has been demonstrated for the constructs (PA, SN, PBC, EI and EB) in the measurement model.

Once a satisfactory measurement model was obtained, the second step, involving SEM, was to test the structural model. The structural model



includes the hypothesized relationships among constructs (PA, SN, PBC, EI and EB) in the research model. The overall goodness of fit statistics showed that the structural model fits the data well (Table 4).

Having assessed the fit indices for the measurement model and the structural model, the estimated coefficients of the causal relationships among constructs were examined (Figure 2).

From Table 5 and Figure 2, it can be seen that the predictive positive effect of EI to EB is supported ( $H_1$ :  $\beta=0.41$ ,  $t$ -value=5.88,  $p<0.001$ ), which corresponds to the first research hypothesis. The second hypothesis is also supported, that is the PBC have a positive effect on EB ( $H_2$ :  $\beta=0.35$ ,  $t$ -value=5.05,  $p<0.001$ ). The PA, SN and PBC also have a significant impact on EI. Therefore,  $H_3$ ,  $H_4$  and  $H_5$  are supported.

Our findings show that  $R^2$  for EI and EB were 0.46 and 0.45, respectively. So that, these three construct (PBC, PA and SN) determinants accounts for 46% of the variance in EI. The combined effects of PA, SN, PBC and EI also explain 45% of the variance in EB.

## CONCLUSIONS AND RECOMMENDATION

In this study, the researchers sought answers to the question of what factors contribute to the entrepreneurial behavior among agricultural students in Razi University, Iran. In order to obtain some explanations for that, an entrepreneurial intention model, based on the Azjen's theory of planned behavior, was applied. This theory was considered an appropriate tool to modeling the development of entrepreneurial intention and behavior through pedagogical processes and learning contexts.

Based on the theory of planned behavior, intention is considered the single best predictor of behavior. In turn, the intention of carrying out entrepreneurial behaviours may be affected by several factors such as needs, values, wants and beliefs (Bird 1989; Linan & Chen 2009), as well as the motivational factors (Ajzen 1991). The results of the present study also showed that the entrepreneurial intention was the single best predictor of behavior. This finding is also in line with the findings of Armitage and Conner (2001),

Barani et al. (2011), Ajzen (1991) & Bird (1989).

Furthermore, the core of theory of planned behavior model is generally supported by the analysis, confirming that subjective norms, personal attitude toward entrepreneurship and perceived behavioral control are highly correlated with entrepreneurial intention and behavior, which in turn are consistent with the findings of previous studies with students' samples (Krueger, 2000; Autio et al., 2001; Linan & Chen, 2009; Engle et al., 2010; Iakovleva et al., 2011; Barani et al., 2011; Moriano et al., 2012; Karimi et al., 2013; Karimi, 2014; Papzan et al., 2013). Given this, the findings of the present study provide support for the usability of the process approach to analyzing entrepreneurial behavior. It has been demonstrated that the intention model in this study is a rigorous frame work when it comes to explaining or predicting variations in entrepreneurial intentions and behaviour.

Regarding the pattern of relationships shown in the model, one important finding is the significant role of subjective norm in the TPB. While, in the area of entrepreneurship, the role of subjective norm in the TPB is not so clear, some authors choose to simply omitted subjective norms (e.g., Veciana et al. 2005), while others found it to be non-significant (e.g. Krueger, 2000; Barani & Zarafshani, 2010; Solimani & Zarafshani, 2012). Yet, some studies found SN to significantly explain EI (e.g., Kolvereid & Isaksen 2006; Barani et al., 2011; Karimi, 2014; Papzan et al., 2013). Furthermore, this finding contradicts the findings of Autio et al. (2001) and Krueger (2000) who both showed SN to be the weakest and non-significant predictor of EI. Present findings' also contradicts the findings of Moriano et al. (2012), Barani and Zarafshani (2010), Solimani and Zarafshani (2012) and Karimi et al. (2012, 2013), who showed SN to be the weakest and non-significant predictor of EI among students in Iran.

In general, present findings' confirm the findings of previous studies in terms of finding a significant relationship between entrepreneurial intention and its motivational factors (PA, SN and PBC) and thereby lending further support to the application of Ajzen's theory of planned

behavior to predicting and understanding entrepreneurial behavior.

To promote the entrepreneurial intention and behavior and hence to reduce the unemployment among educated groups in Iranian higher agricultural education system with respect to the present findings, the following suggestions are offered:

1- Since the attitudes toward entrepreneurship has the most direct and significant impact on entrepreneurial intentions of agricultural students, the planners of higher agricultural education are recommended to be dealing with values, needs and importance of entrepreneurship in entrepreneurship training and education in the higher agricultural education system and so that a positive attitude toward this issue (entrepreneurship) is created.

2- Since the perceived behavioral control has the significantly direct effect on entrepreneurial intention and behavior of agricultural students, the planners of higher agricultural education are recommended to employ the problem-solving method of teaching, training, and learning self-mastery in higher agricultural education system, and also, to hold workshops and educational projects that can strengthen perceived behavioral control.

3- Since the subjective norms play a significant role in entrepreneurial intention, the planners of higher agricultural education are recommended to pay attention to the role of cultural values and social norms as one of the determinant of entrepreneurial intention and behavior and future career of college students and also to promote entrepreneurship culture and attention to entrepreneurs and acknowledge them through mass media.

4- Other factors affecting entrepreneurial intentions and behavior of students in higher agricultural education should be further studied, and based on the results of the present study; a number of measures should be taken to help promote the entrepreneurial intentions and behavior of students in higher agricultural education system.

#### ACKNOWLEDGEMENT

This research was funded by Iran's National Elites Foundation (INEF). We thank our colleagues from INEF for their financial support, insight and expertise to carry out this study.

#### REFERENCES

- Ajzen, I., & Fishbein, M. (1980). *Understanding attitudes and predicting social behavior*. Englewood Cliffs, NJ: Prentice Hall.
- Ajzen, I. (1991). Theory of planned behavior. *Organizational Behavior and Human Decision Processes*, 50, 179-211.
- Ajzen, I. (2002). Perceived behavioral control, self-efficacy, locus of control and the theory of planned behavior. *Journal of Applied Social Psychology*, 32, 1-20.
- Armitage, C. J., & Conner, M. (2001). Efficacy of the theory of planned behavior: A meta-analytic review. *British Journal of Social Psychology*, 40, 471-499.
- Autio, E., Keeley, R. H., Klofsten, M., Parker, G. G. C., & Hay, M. (2001). Entrepreneurial intent among students in Scandinavia and in the USA. *Enterprise and Innovation Management Studies*, 2, 145-160.
- Bagozzi, R., Baumgartner, H., & Yi, Y. (1989). An investigation into the role of intentions as mediators of the attitude-behavior relationship. *Journal of Economic Psychology*, 10, 35 – 62.
- Bandura, A. (1982). Self-efficacy mechanism in human agency. *American Psychologist*, 37, 122-147.
- Bandura, A. (2001). Social cognitive theory: An agentic perspective. *Annual Review of Psychology*, 52, 1-26.
- Barani, Sh., & Zarafshani, K. (2009). A determination of the effect of attitude towards entrepreneurship, social norm, and self-efficacy in predicting entrepreneurial intentions among rural development management students at Payame-Noor University, Kermanshah. *Iranian Journal of Agricultural Economics and Development*, 40-2 (3), 91-99.
- Barani, Sh., Zarafshani, K., Del-Angizan, S., & Hosseni Lorgani, S. M. (2011). The impact of entrepreneurship education on entrepreneurial behavior of students Payam-Noor University of Kermanshah: structural equation modeling approach. *Journal of Research and Planning in Higher Education*, 57, 85-105.
- Bird, B. (1988). Implementing entrepreneurial ideas: The case for intentions. *Academy of Management Review*, 13, 442-453.

- Carree, M., & Thurik, R. (2006). Understanding the role of entrepreneurship for economic growth. In M. A. Carree & A. R. Thurik (eds.) the Handbook Entrepreneurship and Economic Growth. Cheltenham, UK and Northampton, MA, US: Edward Elgar Publishing Limited. [Http://people.umass.edu/aizen/](http://people.umass.edu/aizen/).
- Dam, K. V., Schipper, M., & Runhaar, P. (2010). Developing a competency-based framework for teachers' entrepreneurial behavior. *Teaching and Teacher Education*, 26, 965-971.
- Douglas, E. J., & Shepherd, D. A. (2002). Self-employment as a career choice: Attitudes, entrepreneurial intentions, and utility maximization. *Entrepreneurship Theory and Practice*, 26, 81-90.
- Engle, R.L., Dimitriadi, N., Gavidia, J.V., Schlaegel, C., Delanoe, S., Alvarado, I., & Wolff, B. (2010). Entrepreneurial intent: A twelve-country evaluation of Ajzen's model of planned behavior. *International Journal of Entrepreneurial Behavior and Research*, 16(1), 35-57.
- European Community (1999). Action plan for promoting entrepreneurship and competitiveness. Luxembourg: Office for Official Publications of the European Communities.
- Fornell, C., & Larcker, D. (1981). Structural equation models with unobservable variables and measurement error. *Journal of Marketing Research*, 18(1), 39-50.
- Gartner, W. B., Shaver, K. G., Gatewood, E. J., & Katz, J. (1994). Finding the entrepreneur in entrepreneurship. *Entrepreneurship Theory and Practice*, 18, 5-10.
- Ghasemi, J. Asadi, A., & Hoseninia, Gh. (2009). Investigating factors affecting entrepreneurial mentality of Tehran University's graduate students. *Iranian Journal of Agricultural Economics and Development*, 40-2 (2), 71-79.
- Hair, J. F., Anderson, R. E., Tatham, R. L., & Black, W.C. (2010). *Multivariate data analysis* (7<sup>th</sup> Ed.). New Jersey: Prentice Hall International, Inc.
- Henry, C., Hill, F., & Leitch, C. (2005). Entrepreneurship education and training: can entrepreneurship be taught. *Education and Training*, 47 (3), 158-169.
- Iakovleva, T., Kolvereid, L. & Stephan, U. (2011). Entrepreneurial intentions in developing and developed countries. *Education and Training*, 53(5), 353-370.
- Karimi, S. (2014). *Analyzing and promoting entrepreneurship in Iranian higher education*. Submitted in fulfillment of the requirements for the degree of doctor at Wageningen University. Unpublished dissertation, Wageningen University, Wageningen, NL (2014) with references, with summaries in English, Dutch and Persian, ISBN 978-94-6173-845-5
- Karimi, S., Biemans, H. J. A., Lans, T., Chizari, M., Mulder, M., & Naderi Mahdei, K. (2013). Understanding role models and gender influences on entrepreneurial intentions among college students. *Social and Behavioral Sciences*, 93, 204-214.
- Karimi, S., Biemans, H. J. A., Lans, T., Mulder, M., & Chizari, M. (2012). The role of entrepreneurship education in developing students' entrepreneurial intentions. Retrieved from SSRN: <http://ssrn.com/abstract=2152944>.
- Krejcie, R. V., & Morgan, D. W. (1970). Determining sample size for research activities. *Educational and Psychological Measurement*, 30, 607-610.
- Krueger, N.F., & Carsrud, A.L. (1993). Entrepreneurial intentions: Applying the theory of planned behavior. *Entrepreneurship and Regional Development*, 5, 316-323.
- Krueger, N.F. (2000). The cognitive infrastructure of opportunity emergence. *Entrepreneurship Theory and Practice*, 24, 5-23.
- Learned, K. E. (1992). What happened before the organization? A model of organization formation. *Entrepreneurship Theory and Practice*, 17, 39-48.
- Leroy, H. Maes, J. Meuleman, M. Sels, L., & Debrulle, J. (2009). Gender effect on entrepreneurial intentions. A TPB multi-group analysis at factor and indicator level. Retrieved from <http://lambda.qsensei.com/content/1mjc03>.
- Linan, F., & Chen, Y. W. (2009). Development and cross-cultural application of a specific instrument to measure entrepreneurial intentions. *Entrepreneurship Theory and Practice*, 33, 593-617.
- Linan, F., Nabi, Gh. & Krueger, N. (2013). British and Spanish entrepreneurial intentions: A

- comparative study. *Revista De Economía Mundial*, 33, 73-103.
- Moriano, J.A., Gorgievski, M., Laguna, M., Stephan, U., & Zarafshani, K. (2012). A cross-cultural approach to understanding entrepreneurial intention. *Journal of Career Development*, 39 (2), 162-158.
- Nabi, G., & Liñán, F. (2011). Graduate entrepreneurship in the developing world: intentions, education and development. *Education and Training*, 53(5), 325-334.
- Nunnally, J.C., & Bernstein, I.H. (1994). Psychometric theory (3rd ed.). New York: McGraw-Hill.
- Onstenk, J. (2003). Entrepreneurship and vocational education. *European Educational Research Journal*, 2, 74- 89.
- Papzan, A. H., Afsharzadeh, N., & Moradi, Kh. (2013). Entrepreneurial intention determinants: An empirical model and a case of Iranian students in Malaysia. *Journal of Entrepreneurship Management and Innovation*, 9 (3), 43-55.
- Peterman, N., & Kennedy, J. (2003). Enterprise education: influencing students' perceptions of entrepreneurship. *Entrepreneurship Theory and Practice*, 28, 129 – 135.
- Shapero, A. (1982). Social dimensions of entrepreneurship. In C.A. Kent, D.L. Sexton, and K. Vesper (Eds.), *the encyclopedia of entrepreneurship* (p. 72-90). Englewood Cliffs, NJ: Prentice Hall.
- Shiri, N., Mohammadi, D., & Hosseini, S. M. (2012). Entrepreneurial intention of agricultural students: Effects of role model, social support, social norms and perceived desirability. *Archives of Applied Science Research*, 4(2), 892-897.
- Shook, C.L. Priem, R.L., & McGee, J.E. (2003). Venture creation and the enterprising individual: a review and synthesis. *Journal of Management*, 29, 379 – 399.
- Solimani, A., & Zarafshani, K. (2011). Explaining predictors of entrepreneurial intentions among the students of “Khoshehaye Zarin” Agricultural-Vocational School in Ravansar Town in Kermanshah Province. *Journal of New Approaches in Educational Administration*, 2 (7), 107-124.
- Thompson, E.R. (2009). Individual entrepreneurial intent: construct clarification and development of an internationally reliable metric. *Entrepreneurship Theory and Practice*, 33(3), 669-694.
- Tkachev, A., & Kolvereid, L. (1999). Self-employment intentions among Russian students. *Entrepreneurship and Regional Development*, 11, 269-280.
- Van-Gelderen, M., Brand, M., van Praag, M., Bodewes, W., Poutsma, E., & van Gils, A. (2008). Explaining entrepreneurial intentions by means of the theory of planned behaviour. *Career Development International*, 13, 538-559.
- Veciana, J. M. Aponte, M., & Urbano, D. (2005). University student's attitudes toward entrepreneurship: A tow countries comparison. *International Entrepreneurship and Management Journal*, 1(2), 165- 182.
- Zhao, H. Siebert, S.E., & Lumpkin, G.T. (2010). The Relationship of Personality to Entrepreneurial Intentions and performance: A Meta-Analytic Review. *Journal of Management*, 36, 381 – 404.

**How to cite this article:**

Shiri, N., Mirakzadeh, A., & Zarafshani, K. (2017). Promoting entrepreneurial behavior among agricultural students: A Two-Step Approach to structural equation modeling. *International Journal of Agricultural Management and Development*, 7(2), 211-221.

URL: [http://ijamad.iaurasht.ac.ir/article\\_527223\\_3df56b80749a287db9410f03aafe8f75.pdf](http://ijamad.iaurasht.ac.ir/article_527223_3df56b80749a287db9410f03aafe8f75.pdf)

