



**AgEcon** SEARCH  
RESEARCH IN AGRICULTURAL & APPLIED ECONOMICS

*The World's Largest Open Access Agricultural & Applied Economics Digital Library*

**This document is discoverable and free to researchers across the globe due to the work of AgEcon Search.**

**Help ensure our sustainability.**

Give to AgEcon Search

AgEcon Search

<http://ageconsearch.umn.edu>

[aesearch@umn.edu](mailto:aesearch@umn.edu)

*Papers downloaded from **AgEcon Search** may be used for non-commercial purposes and personal study only. No other use, including posting to another Internet site, is permitted without permission from the copyright owner (not AgEcon Search), or as allowed under the provisions of Fair Use, U.S. Copyright Act, Title 17 U.S.C.*

## SUPPLY CHAIN OF VEGETABLE FORCING IN HUNGARY

TÉGLA Zsolt – SZÚCS Csaba

---

### Abstract

The competitiveness of the economic actors is basically determined by the efficiency of their supply chain. The optimization works best if it begins at the end user of the supply chain and the planning starts with determining the needs and requirements. All the elements of each sub-process can be simulated from sales (in the case of biomass it means incineration in a heating plant) through production (establishing energy forests) to the packed fresh vegetables grown in the cultivation equipment. The firms interconnected in the supply chain represent potential markets for research because the current uncertain economic situation poses a major challenge for business leaders in decision-making. The

goals is to create intelligent employment plants which allow profit to remain in the rural areas, provide healthy fresh vegetables at a very affordable price, and also generate revenue for the owner in a predictable way. The use of a logistic approach at every stage of forced vegetable production is timely. The logistics optimization and unification of the “softened, 95%” monitoring system is needed in the greenhouse vegetable forcing.

**Keywords:** supply chain management, renewable resources, employment, competitiveness, logistics information systems, traceability

**JEL Code:** L23, O13, Q42,

---

### Introduction

The supply chain of fresh agricultural products basically leaves the internal features of agricultural or manufactured products intact. In the case of such products the main processes are handling, storage, packaging, distribution, and sales. (Van der Vorst et al., 2005)

The distribution chain actors are aware that even the high quality products are exposed to deterioration over time in the distribution chain and the decay rate is highly dependent on the environmental variables (Van der Vorst et al., 2005).

The competitiveness of fresh (raw) products obtained through vegetable forcing depends largely on what kind of processing levels / added value they represent. When purchasing goods customers use their eyes therefore packaging determines the value of the product to a large extent. Packaged products can be sold at a 30-40% higher price. At the same time packaging is also important from a logistics point of view because it is also a cost-saving factor. (Mathias M. C. 2007)

Logistical costs are related to the costs of existing models and tools, as well as resources. For example when storing is necessary the operation cost includes the cost of material handling and storing as well. The inventory shortages may result in decreasing market share or increased risks of production. (Boute et.al, 2011)

Monitoring of the usage time period is essential in handling stocks so that no goods could remain in the warehouse or distribution network after the warranty period is expired. (Bentley, 2011)

The distribution logistics systems including both small grocery stores and large department stores increasingly require convenient packaging.

The law regulated traceability of goods from producers of consumers can be managed significantly more easily if the goods are transported to the point of sale readily packed and properly signed and marked. Filling the shelves in the sales area is simpler and less labour-intensive when peppers, tomatoes and other greenhouse vegetables are delivered in appropriate packaging and compartments to the shop. Due to the high labour-intensive nature of packaging of forced vegetables more jobs may be created while these costs can be realised in the price of the final product.

## **Materials and methods**

This study focuses on how adequately the principles of logistics are applied in vegetable forcing farms. In modern logistics system not only vegetable forcing farms / businesses compete for the consumer's favour but also the logistics supply chains. "...‘business to business’ logistics, the role of supply chain management as well as information sharing based on mutual benefits in supply chains are becoming increasingly valuable" (Kozma, T. – Gyenge B. 2004).

The competitiveness of fresh (raw) products in the supply chain depends largely on the extent of how much cost reduction and increased level of services are achieved. Therefore, concerning isolated vegetable forcing, beside the economies of scale the costs and materials which can significantly reduce the cumulative logistic costs of the final products through better organization were examined. Such costs include energy (heat), labour, and the logistics costs of harvesting, handling, packing and shipping.

By **strengthening and emphasising the logistical point of view** in this research our aim is to highlight the fact that the performance of the supply chain is applicable only in its entirety because the **customer** – through their intention of purchase as well as their judgment about the cost, quality, and availability of goods – **formulates an opinion about the entire supply chain**.

During the research, attempts were made to reveal the most important dimensions of the study area from a logistics point of view highlighting the dimensions of the well-known 9Rs model. In the interpretation of the individual dimensions of conformity **secondary research, literature review** (e.g. economies of scale analyses, models presented) were carried out and during the interpretation of the cost dimension the **components of the cost function were analysed**, and simulation method was applied for the optimization of harvest and transport.

## Results

Not in harmony with the usual editing process before the analysis we first summarize the results and findings that our investigation was based on and the ones that were carried out in earlier experiments:

Hungary has unique qualities from a geothermal point of view. One obvious possibility of thermal water utilisation is to heat greenhouses. At the same time, the utilisation of poor quality fallow agricultural land under 17 Gold Crown must be solved. These areas can be used well and effectively for growing arboreal energy plants without competing with food production. In order to maximize the comparative advantages vegetable forcing farms of economies of scale sizes are needed. Based on our research, owing to high investment costs and the production of single market commodity, **in the long run only 3-5 hectare farms can be competitive taken into account the economies of scale and logistical aspects.**

However, no investment into large, economies of scale vegetable forcing farms were realised in the past 20 years, nor were there any comprehensive strategic plans created. Renewable resources based vegetable forcing could mean a shift for the country towards resource utilizations which may increase employment, enhance environment protection, reduce the country's dependence on imports and improve the rate of domestic energy sources in harmony with the country's energy potential. **As heating is one of the most significant costs of vegetable production in greenhouses, decreasing its volume and the use of domestic natural resources can significantly improve the competitiveness of the final product.**

Nowadays people living in rural areas in Hungary have neither modern facilities nor the capital necessary to build them and their only resource is their capability to work. In addition to the manufacturing industry only vegetable forcing, most specifically the hydroculture cultivation is suitable for year-round employment of labour, which is the individual characteristics and great advantage of vegetable forcing within the horticultural sector. A 5 hectare farm can employ a total of 67 people – of whom 60 people are trained workers, 6 skilled workers and 1 highly educated plant manager. Where it is necessary to plant arboreal energy crops to produce the required raw materials for heating, in the first year a further 15 people must be employed for the period of one year. From the second year 5 people can be employed for 4 months a year during the winter harvest season. **We concluded that the required investment per employee – depending on the farm size – varies between HUF 21-24 million, which is approximately 25% of the average investment requirement in other sectors such as the automobile industry.** In modern greenhouses 40-50 kg of tomato and 25 kg paprika can be produced per one square metre between January and December, which means that a 5 hectare farm will produce 2000 to 2500 tons of tomato and 1250 tons of paprika. (Tégla, 2012)

Due to the isolated cultivation and biological crop protection pesticide free healthy vegetables can be produced. The healthy, high-quality, and high-volume vegetables provide a basis for negotiating with major supermarket chains, furthermore the substantially lower production costs they can be competitive against goods from the southern Mediterranean countries imported between March and November. In order to be able to obtain competitive prices for the final product the logistics principles and criteria must be met within the logistics supply chain.

## **Description of business models in this study**

The following objectives were formulated during the design of the tested business models:

- The vegetable forcing models should produce goods at competitive prices, the average annual cost must be less than 1 Euro/kg.
- The models should allow for the production of 2-3 or occasionally 4 trucks (33 pallets) of goods per week from March to December.
- During the business planning the principle of conservative estimate should be applied for investment and production cost calculations.
  
- The essence of the business models is to provide answers for the country's most pressing problems – such as employment, increasing the proportion of renewable energy, improvement of rural areas – utilising the available resources and also that they should be feasible in any geographical area.

**Based on the analysis of the different business models three vegetable forcing models were created by us in accordance with the above presented principles:**

### **Model 1:**

In areas where the amount, the quality and the temperature of thermal waters are adequate (2 x1000 litre/min thermal wells producing 60°C water are available), solely geothermal (thermal water) energy-based heating systems is viable. In Hungary primarily these farms are sustainable, taking into account the country's geothermal potential.

### **Model 2:**

Where there is insufficient amount of thermal water with appropriate temperature available (800 litres/min thermal wells producing 60°C water), the combined use of thermal water and biomass (wood chips) is capable of generating the required amount of energy.

Taking everything into consideration today the renewable resource that can be used to the greatest extent is solid biomass. This is also supported by (Magda R, 2011), who believes that biomass is extremely important.

The required 2500 ATRO tons of wood chips can be gained from a 300 hectare arboreal plantation annually. The supply of wood chips, where appropriate, may originate from other locations such as forest management companies. This may be applicable in forested regions.

### **Model 3:**

In areas where the required quantity and temperature thermal water is not available the biomass based solution is reasonable. In this case the necessary amount of biomass (wood chips) can be produced primarily on areas which are difficult to utilise for other agricultural activities. The heating of a 5 hectare greenhouse requires 5000 ATRO tons of wood chips a year the production of which requires 625 hectares of medium quality – 8 ATRO tons /ha/year yield – land.

Table 1: The amount of woodchips used in model 3 for the heating of 3 to 5 hectare farms

Total amount of necessary woodchips in ATRO tons	3 hectare farm	5 hectare farm
	3 000	5 000
The amount of wood chips at 50% water content (tons)	6 000	10 000
The amount of woodchips used from January to May (tonnes) (50% moisture content)	4 200	7 000
The amount of woodchips used between September and the end of November (tonnes) (50% moisture content)	1 800	3 000

Source: Tégla, 2012

ATRO tons: the weight of wood chips counted at 0% moisture content

### *Analysis (total logistical cost reduction opportunities in vegetable forcing)*

Our research presents the values of the focal points and quantitative relationships of the material flow, energy flow, raw material moving (e.g.: raw materials used for heating), as well as the manual labour requirements in vegetable forcing on farms that are proven to achieve competitive prices and can provide employment all year round.

In the following the most important **criteria and logistics-oriented dimensions** of vegetable forcing farms will be presented by means of the conceptual 9Rs model of logistics.

From a logistical point of view each process component must provide “appropriate” cost dependent output and results. Appropriate according to the following criteria, and includes the appropriate transmission of the first four factors in the supply chain: (Szegedi – Prezenszki, 2010)



Figure 1: The 9Rs criteria of logistics

Source: (Szegedi – Prezenszki, 2010)

In the following, the issues of the first four categories of compliance will be presented in respect of the presented models.

***Appropriate energy (heating energy)***

Concerning energy in logistics the first issue is the required energy resources to run the process. As one of the most determining costs of vegetable production in greenhouses is heating energy, cost savings realized in this area together with the use of domestic natural resources can significantly improve the competitiveness of the final product. Taking into account the natural resources of Hungary we theoretically formulated vegetable forcing farms based on three different modes of heating (solely geothermal energy, combination of geothermal energy and arboreal crops, non-geothermal energy modes).

Renewable resources based vegetable forcing represent a possibility for the country to shift towards resource utilization which increases employment, protects the environment, reduces the country's dependence on imports, and improves the rate of use of domestic energy sources in harmony with the country's energy potential. Underneath the Carpathian Basin, and especially in the area of Hungary, the earth's crust is thinner than average, which provides excellent opportunities from a geothermal point of view in the whole country.

Table 2: Why is it worth implementing and presenting a vegetable forcing project based on geothermal energy and arboreal plantations?

1.	Taking into account its geological endowments Hungary has a unique set of thermal energy resources the utilisation of which in agriculture is negligible compared to the potentials.
2.	The developed models are based on well-established renewable energy resources which produce fresh vegetables at competitive prices (arboreal plantation and geothermal-based automatically controlled biomass heating plant and vegetable forcing).
3.	Vegetable production in greenhouse conditions may contribute to a stable and predictable export growth of agricultural products as it is not exposed to weather conditions.
4.	Vegetable production generates import and together with biological crop protection expands healthy food production.
5.	Arboreal biomass and geothermal energy based (mixed energy) vegetable forcing models have not yet been created commercially.
6.	During the crisis the project produces goods which do not threaten with inflationary price increases since it generates import obviously only if the products can be sold at a lower price than the foreign competitors.
7.	The only rational possibility to utilise areas that are not or only uneconomically used for agricultural purposes (arable and grassland) is renewable biomass production which can be incinerated but does not harm the environment.

Source: own construction

***The right material (the logistical issues of woodchip transport)***

To execute JIT 'just in time', such labour organizational procedure must be sought and applied that considers the strive to cost minimizing (economical running), stresses the alternative of doing work within an optimal period of time, i.e. optimizes plant production processes. The optimum is where the time constraints and cost minimization are realized. By means of working on arable land meeting this double objective is quite a complex task. The definition of capacity and the selection of such a system of instruments adapted to the size of the company, crop rotation, production site (ecological environment, shape of parcels, slopes,

distance from the manor etc.) only hold true in the surroundings where calculations were made. Organizing labour processes is the most economical if the capacity of all machines and machinery participating in the process are fully utilized. The fixed costs of the capacity not covered by sensible operation (loss of time, waiting, idle time) increases the costs of productive performance.

Time function:  $T_{\dot{O}} = (T_R + T_{RV}) + (T_{SZ} + T_{SZV}) + (T_F + T_{FV}) \text{ hour}$

$T_{\dot{O}}$  = total order cycle time, hour/task

$T_R$  = loading

$T_{RV}$  = waiting time of loading machines

$T_{SZ}$  = transportation

$T_{SZV}$  = waiting time of carriers

$T_F$  = processing

$T_{FV}$  = waiting time of processing

### The supply logistic system of biomass based energy cluster

The raw material supply of the virtual energy cluster we analyse can be realised in three ways:

1. At the time of harvesting each production unit transports the high humidity level wood-chips (45-50%) to the central storage facility of the power plant.
2. The harvested amount is stored in temporary storage facilities on the production site, and is transported to the power plant in the rhythm of usage.
3. In the case of large distances micro-regional storage facilities are established for temporary storing the wood-chip output of the given micro-region until the time of usage. Production units nearby still transport directly to the power plant.

Figure 1 is showing these variations.

**Figure 1: Direct and combined supply systems**

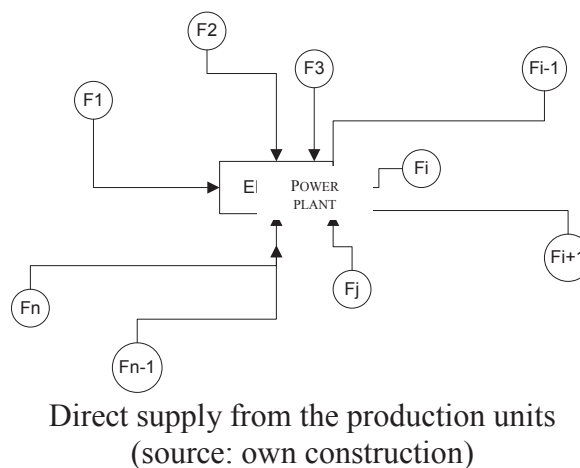
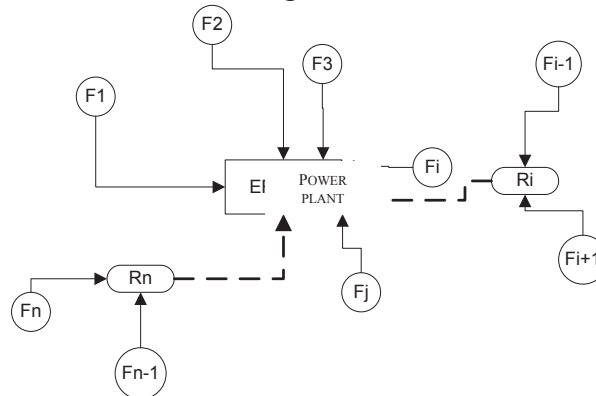



Figure 2



Combined supply with temporary storage facilities ( $R_i$ )  
Source: own construction

We tried analyse which solution leads to the lowest total costs. For this we utilised the heuristic simulative method (RECAM) for optimising harvesting-transport. For establishing the number of regional centres we built a simulation model shown in figure 2. The calculation method applies for the model is the one used by Cselényi (1997).

**First we calculate total costs in the case when we are not using temporary (regional) storage facilities** – everything is transported directly to the power plant (3, 4).

In this case total costs:

$$K = K_{sz} + K_r$$

$K_{sz}$  Cost of transportation  
 $K_r$  Cost of storage = 0 Ft

Total transportation costs:

$$K_{sz} = \sum_{i=1}^n k_i s_i \frac{Q_i}{c_i}$$

- $k_i$  specific cost of transport from field  $i$
- $s_i$  distance from field  $i$  to power plant
- $Q_i$  yield on land  $i$
- $c_i$  capacity of vehicles transporting from field  $i$

During calculation we assumed one kind of transportation and one kind of vehicle. Our RECAM survey showed that MTZ 82 (tractor) + Fliegel EDK 130 (trailer) is the lowest cost means of transport.

If full transport is done by the same machines:

$$k_1 \approx k_2 \approx \dots \approx k_n \quad \text{és} \quad c_1 \approx c_2 \approx \dots \approx c_n$$

The total storage costs:

$$K_r = r_e \bar{R}_e \bar{T}_e$$

- $r_e$  specific maintenance costs of the power plant storage
- $\bar{R}_e$  average stock at the power plant storage
- $\bar{T}_e$  average storage time at the power plant storage

Cost  $K$  resulted will be the base – algorithm cycle starts from here. **After this we analyse the total costs in case of 1,2,...,m storage facilities.** In these cases

$$K = K_{sz} + K_r$$

$K_{sz}$  cost of transportation  
 $K_r$  cost of storage

This time the transportation costs consist of two factors:

$$K_{sz} = K_{sz}^r + K_{sz}^f$$

$K_{sz}^r$  cost of transportation from storage to power plant  
 $K_{sz}^f$  cost of transportation form fields to storage

Detailed calculation is as follows:

$$K_{sz}^r = \sum_{j=1}^m k_{(r)j} s_{(r)j} \frac{Q_{(r)j}}{c_{(r)j}}$$

$k_{(r)j}$  specific cost of transport from storage j  
 $s_{(r)j}$  distance from storage j to power plant  
 $Q_{(r)j}$  yield on fields belonging to storage j  
 $c_{(r)j}$  capacity of vehicles transporting from storage j

This is one of the key factors in calculation since total costs can be reduced significantly if we minimise transportation cost from storage to power plant.

When transporting biomass from filed to storage the following costs arise:

Assuming that storage facilities  $R_1, R_2, \dots, R_m$  are associated with territories  $t_1, t_2, \dots, t_m$

$$K_{sz}^f = \sum_{j=1}^m \sum_{p_j=1}^{t_j} k_{jp_j} s_{jp_j} \frac{Q_{jp_j}}{c_{jp_j}}$$

$k_{jp_j}$  specific cost of transport from field  $p_j$  to storage  $R_j$   
 $s_{jp_j}$  distance from field  $p_j$  to storage  $R_j$   
 $Q_{jp_j}$  yield on fields  $p_j$  belonging to storage  $R_j$   
 $c_{jp_j}$  capacity of vehicles transporting from field  $p_j$  to storage  $R_j$

Storage costs are to calculated here too, of course:

$$K_r = K_r^e + K_r^r$$

$K_r^r$  storage costs of storage facilities  
 $K_r^e$  storage costs of power plant

$$K_r^r = \sum_{j=1}^m r_j \bar{R}_j \bar{T}_j$$

$r_j$  specific maintenance costs of storage  $R_j$   
 $\bar{R}_j$  average stock at storage  $R_j$   
 $\bar{T}_j$  average storage time at storage  $R_j$

In this case total costs are:

$$K = \sum_{j=1}^m k_{(r)j} s_{(r)j} \frac{Q_{(r)j}}{c_{(r)j}} + \sum_{j=1}^m \sum_{p_j=1}^{t_j} k_{jp_j} s_{jp_j} \frac{Q_{jp_j}}{c_{jp_j}} + \sum_{j=1}^m r_j \bar{R}_j \bar{T}_j$$

We should notice that there are going to be fields from which transportation is directly to the power plant. In our calculation in such cases the power plant functions as storage facility but no further transportation is needed.[ 3,4 ]

The following in equation demonstrates things stated above:

$$k_i s_i \frac{Q_i}{c_i} + K_{r_i} < k_{j p_j} s_{j p_j} \frac{Q_{j p_j}}{c_{j p_j}} + k_{(r)j} s_{(r)j} \frac{Q_{(r)j}}{c_{(r)j}} + r_j \bar{R}_j \bar{T}_j$$

Thus, if transportation and storage costs of field i directly to the power plant are lower than total transportation costs to any storage  $R_j$  it is better to transport directly to power plant. This calculation should be performed for all fields and storage facilities. As a result we will be able to see the limits of the area around the power plant within which fields belong directly to the power plant. These fields will transport directly to the plant, the rest to allocated storage facilities.

In logistics systems planning is a fundamental requirement to have **systematic thinking** and the **total cost** approach and also to achieve the 6Rs of logistics (the right goods should get to the customer at the right time, to the right place, in the right quantity, the right quality, and at the right cost). The cost must be emphasized because it is one of the determinants of competitiveness. The total cost approach means that the total cost of the system components should be the minimum. Therefore it is necessary to examine the possibilities to minimise the costs of the individual components of the system and their impacts on each other. The goal is to avoid that the decrease of the costs in one component does not result in an increase of costs in another component in excess of the original reduction.

The produced quantity of the raw material – biomass (arboreal and herbaceous plants) – is determined by the size and the yield per unit of the land. The selection of land suitable for the ecological needs of the plant is essential in order to achieve the expected return. Its size is determined by the demand in most cases, total energy demand on the basis of the raw material requirement of the existing or planned power plant = obtainable energy on a unit of area x size of the area.

Obviously, it may occur that a large area is suitable (competitive with food crops cultivation) for biomass production. In such a case the product may be sold in some processed form (pellets, briquettes) and the so called supply market develops and as a result the supply chain function in the PUSH mode.

It is more likely that where the incineration biomass logistics cluster systems are developed the PULL mode will be applied as the quantity of the produced biomass is determined by the demand of the local-, micro-regional- and regional clusters and consumers based on needs, time and quantity. Naturally, the storage of the excess products must also be considered. (The surplus product may affect the purchase price, the additional transportation and storage costs increase the logistics costs, thus reduce competitiveness.)

The specialty of the system is that the production of the raw materials takes place on agricultural land, the harvest of the product falls on a certain predetermined time of the year. In order to ensure continuous supply the role of the cropping pattern, the plantation structure, and the varieties become increasingly important.

The **competitiveness** of incinerated biomass is determined by two factors. On the one hand its production must be competitive with other food or fodder production, and on the other the generated heat and electricity must compete with fossil energy sources.

It is important to note that with minor changes and with the common use of the instruments, planters, harvesters and adapters already available for small agricultural enterprises can be used effectively. The utilization of machinery and equipment improves, and it becomes possible to have integrators and develop a common storage space etc.

All of these factors reveal that the decision is influenced by the habitat, as well as economic, technological and logistical etc. factors, therefore it is likely that as a result of all the factors a so-called biomass mix is created in each energy cluster.

Logistically, the most important and most costly component of production is the process of harvesting and transport (heavy weight, large distance). It is therefore particularly important that the operation is organized in harmony with the logistical principles in mind so that the costs can be minimized. This can be achieved by the entire synchronisation of the process elements of the harvest, transport, and reception of the products.

### *The right human resources*

Vegetable forcing without soil offers excellent employment opportunities, facilitates continuous employment, while supporting high area and revenue proportional income through technological intensity and the characteristics of the products. (Hágen-Marselek 2010)

Based on experience an average “hard worker” is capable of performing all the caring, harvesting and product preparation work of a 1250 m<sup>2</sup> vegetable forcing area throughout the year.

To determine labour needs for each of the three vegetables the most important work processes such as planting, nursing, integrated pest control, picking, harvesting, sorting and product preparation, liquidation of stock and other jobs had to be considered. Table 2 reveals the development of labour demand in hydroculture paprika, tomato, and cucumber forcing.

Table 2: The development of labour demand in the case of the most important vegetables

The development of manual labour demand	Paprika (hours)		Tomato (hours)		Cucumber (hours)	
	1000 m <sup>2</sup>	5 ha	1000 m <sup>2</sup>	5 ha	1000 m <sup>2</sup>	5 ha
preparation for planting	10	500	10	500	18	900
planting	35	1 750	37	1 850	45	2 250
binding	40	2 000	40	2 000	45	2 250
nursing jobs	185	9 250	125	6 250	190	9 500
biological pest control	50	2 500	50	2 500	50	2 500
picking, harvesting	680	34 000	750	37 500	770	38 500
selection, preparation	240	12 000	210	10 500	180	9 000
liquidation of stock	10	500	13	650	12	600
other (heating, maintenance)	35	1 750	38	1 900	35	1 750
<b>Total working hours</b>	<b>1 285</b>	<b>64 250</b>	<b>1 273</b>	<b>63 650</b>	<b>1 345</b>	<b>67 250</b>

Source: Téglá, 2012

The Netherlands and Belgium, which have a key role globally in vegetable forcing, are characterised by highly advanced technology which is a result of 50 years of continuous development. The rising costs justified the increase of farm sizes and the related automation. The continuous increase of artificially-lit areas can be observed in these countries. As opposed to Spain the Netherlands has a huge competitive advantage in respect of shipping costs since it is situated in the middle of a community of almost 250 million. The biggest problem is the cost of labour, which can reach €15 to 16 per hour, which can be 30-35% of the total production cost. Hence, in the long run only the perfectly automated farms can be competitive. (Tégla-Marselek 2008)

In the case of cucumber, 2/3 of the cost is made up by wages related to harvesting and preparation activities. If the work-related expenses for the whole period amount to €16, including the producer, and if 2/3 of it can be saved, we can talk about a significant batch. This is why the Netherlands are characterised by high level of automation in the greenhouses. (Visser, 2007)

The harvest and the closely related handling processes require significant manual labour and represent labour peaks in vegetable forcing. Order picking and the preceding packing significantly increase the logistical competitiveness of products. This way goods can be delivered to supermarkets in a palletized form thus correct timing can be observed during the distribution of fresh vegetables.

### ***The right information***

Communication between business partners, i.e. the data flow, is the basis for all other physical process, it is becoming more and more important in modern economies. It is therefore increasingly important that enterprises in the supply chain share information generated in the production and delivery of product as much as possible.

ICT technologies must be used to measure labour performance, to optimise production and logistics processes, to make the products (fresh vegetables) adequately traceable, as well as to ensure this flow of information to satisfy customer requirements.

GI protection (protected geographical indication) and quality assurance (GLOBALGAP) are the fundamentals of the logistical competitiveness of fresh forced vegetables. A good example is the PGI and quality assurance of “Szentesi Pepper” and its delivery to supermarkets.

95% of the packaged vegetable is monitored, which means that the producer, the technology (biological pest control, GLOBALGAP quality assurance), and the time of delivery can be determined exactly. The PGI also ensures that the mark is applied only on fresh vegetables from a defined geographical area. This means that the customer can get accurate and reliable information on the fundamental aspects of production, material moving, packing and shipping (producer labels, packaging production number series), which greatly increases confidence. The pelleted fresh vegetables are delivered from the cold storage where the order picking is completed to the supermarkets exactly observing the gate times. The specialization and adaptation of information and communication technologies for the production of high value-added fresh food is a novelty in these sectors therefore its complete development is timely and justified.

## Conclusions

In summary, the domestic vegetable forcing will only have a future if the final products which often originate from fairly impoverished rural regions represent higher levels of processing and is able to meet high qualitative and quantitative criteria and thus continuously satisfy increased customer needs.

This requires a single, clear strategy and programs that ensures long-term employment and livelihood for the rural population by utilizing renewable resources.

As far as rural development is concerned farms that are capable of providing continuous employment of labour must be deployed in disadvantaged areas since this way the logistics costs (transport) can significantly be optimized.

The goal is to create intelligent farms that allow the added value to be retained in rural areas, produce healthy fresh vegetables at an affordable price, and also generate revenue for the owner in a transparent manner. However, to achieve these objectives specialized training and education are needed, because without appropriate human resources the different technologies are unviable.

The application of the logistical approach in every stage of vegetable forcing is timely. The "softened, 95%" logistics optimization and monitoring system is needed to unify the greenhouse vegetable cultivation. The logistics optimization and unification of the "softened, 95%" monitoring system is needed in the greenhouse vegetable forcing.

## References:

- Hágen I. Zs. – Marselek S (2010). : A fenntartható agrárgazdaság szempontjai konkrét vizsgálatok alapján a kertészetben és az állattenyésztésben LII. Georgikon Napok Nemzetközi Tudományos Konferencia PE Georgikon Kar Keszthely 2010. 09. 30. – 10. 01. CD present
- Kozma, T., Gyenge, B. (2004): Quality in Logistics. MendelNet 2004, Sborník abstraktu z konference studentu doktorského studia, Brno, CD, p. 5 (ISBN 80-7302-088-2)
- Magda R. (2011): A megújuló erőforrások szerepe és hatásai a hazai agrárgazdaságban. *Gazdálkodás*, 55. évf. 6. sz. 575-588. p.
- Mathias M. C. (2007): Market shift towards a balance in North America. In: *Fruit & Vegtech*. 7.3 2007.
- Robert Boute, Ronald Van Dierdonck, AnnVereecke (2011): Orgaizing for supply chain management , *International Journal of Logistics: Research and Applications*, vol 14 No. 5, pp. 279-315
- Szegedi Zoltán-Prezenszki József: *Logisztika-menedzsment*. 4. javított, bővített kiadás, Kossuth, 2010, p. 29-31
- Tégla Zs – Marselek S. (2008): Méretökonómia a zöldségajtatásban *Zöldségtermesztés* XXXIX. évf. 3. szám 21–26. p.
- Tégla Zs. (2009): A zöldségajtatás méretökonómiai kérdései. Doktori Phd értekezés. SZIE *Gazdálkodás- és Szervezéstudományi Doktoriskola*
- Tégla Zs. - Hágen I. - Holló E., - Takácsné-György K. 2012: Adoption of Logistic principles in WOODY-biomass energy clusters, *Review of Applied Socio- Economic Research*,

REASER 4 2012 (Volume 4, Issue 2/ 2012 ), pp. 236 ISSN: 2247-6172; ISSN-L: 2247-6172

Van der Vorst , J.G.A.J., Tromp, S., and Van der Zee, D.J. (2005): A simulation environment for the redesign of food supply chain networks: modeling quality controlled logistics. Proceedings of the 2005 Winter Simulation Conference. 1658-1667.

Visser P. (2007): Automatic cucumber harvesting. Fruit & Veg Tech. 7.4. 2007

Yongmei Bentley (2011): Managers' perspectives of logistics and supply chain during the recent economic downturn, International Journal of Logistics: Research and Applications vol 14 No. 6, pp. 427-441

**Authors:**

**Dr. TÉGLA Zsolt**

associate professor

Károly Róbert College

Institute of Business Sciences

[zstegla@karolyrobert.hu](mailto:zstegla@karolyrobert.hu)

**Dr. SZÚCS Csaba**

assistant professor

Károly Róbert College

Institute of Tourism, Regional Development and Foreign Languages

[szucscsaba@karolyrobert.hu](mailto:szucscsaba@karolyrobert.hu)