



AgEcon SEARCH
RESEARCH IN AGRICULTURAL & APPLIED ECONOMICS

The World's Largest Open Access Agricultural & Applied Economics Digital Library

This document is discoverable and free to researchers across the globe due to the work of AgEcon Search.

Help ensure our sustainability.

Give to AgEcon Search

AgEcon Search
<http://ageconsearch.umn.edu>
aesearch@umn.edu

*Papers downloaded from **AgEcon Search** may be used for non-commercial purposes and personal study only. No other use, including posting to another Internet site, is permitted without permission from the copyright owner (not AgEcon Search), or as allowed under the provisions of Fair Use, U.S. Copyright Act, Title 17 U.S.C.*

December 1990

A.E. Ext. 90-30

**New York
Economic Handbook
1991**

**AGRICULTURAL SITUATION
AND OUTLOOK**

Department of Agricultural Economics
New York State College of Agriculture and Life Sciences
A Statutory College of the State University
Cornell University, Ithaca, New York 14853-7801

It is the policy of Cornell University actively to support equality of educational and employment opportunity. No person shall be denied admission to any educational program or activity or be denied employment on the basis of any legally prohibited discrimination involving, but not limited to, such factors as race, color, creed, religion, national or ethnic origin, sex, age or handicap. The University is committed to the maintenance of affirmative action programs which will assure the continuation of such equality of opportunity.

TABLE OF CONTENTS

<u>Section</u>	<u>Prepared by</u> ¹	<u>Page</u>
Economic Situation	B.F. Stanton	2
Marketing Costs	G.A. German David Russo	15
Finance	E.L. LaDue	21
Real Estate	G.L. Casler	29
Grain and Feed	G.L. Casler	33
Fruit	G.B. White	39
Vegetables	E.E. Figueroa	51
Ornamentals	E.E. Figueroa	59
Poultry	P. W. Aho ³	64
Livestock	Caroline Rasmussen ⁴ D.G. Fox ⁴	67
Dairy	M. Keniston W.A. Knoblauch A.M. Novakovic L.D. Putnam W.C. Wasserman ²	74

¹Department of Agricultural Economics unless specifically indicated.

²Extension Specialist.

³Department of Poultry and Avian Science.

⁴Department of Animal Science.

This publication contains information pertaining to the general economic situation and New York agriculture. It is prepared primarily for use of professional agricultural workers in New York State. USDA reports provide current reference material pertaining to the nation's agricultural situation.

"Current Economic Situation" is a two-page monthly release that carries the latest figures for selected economic indicators and highlights current developments. This release is a supplement to the Economic Handbook and is available to anyone requesting to be on the mailing list by writing to the Department of Agricultural Economics, Cornell University, 445 Warren Hall, Ithaca, New York 14853-7801.

NATIONAL OUTPUT, INCOME AND SPENDING
Components of Gross National Product

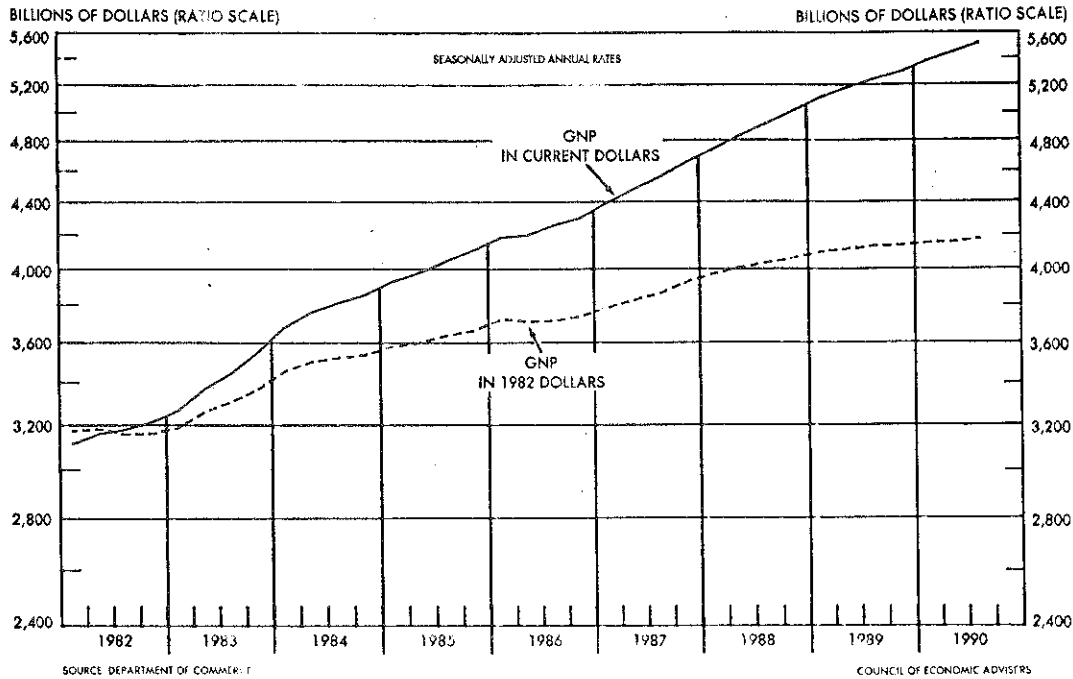

	Gross national product	Personal consumption expenditures	Gross private domestic investment	Government purchase goods and services	Net exports goods & services
- billions of current dollars -					
1981	3053	1915	516	588	34
1982	3166	2051	447	642	26
1983	3406	2235	502	675	-6
1984	3772	2430	665	736	-59
1985	4015	2629	643	821	-78
1986	4232	2797	659	872	-97
1987	4516	3009	700	921	-115
1988	4874	3238	747	963	-74
1989	5201	3450	771	1026	-46
1990	(5500)	(3650)	(760)	(1090)	(-25)

Concern about the slow rates of growth in the economy during the first three quarters of 1990 has resulted in talk about recession, how long it will last, and how deep it may become. At the end of 1990 most forecasters are talking about a mild recession nationally, perhaps lasting three or four quarters and well into 1991. For much of the Northeast there has been a period of no growth or downturn during much of 1990. State and local governments have felt the pinch in reduced tax revenues at the same time as needs for services are increasing. If the national economy is able to move out of its period of no growth in the next 12 months the Northeast should show improvement as well. Conversely if the US slowdown is a harbinger of world recession then the period of recovery will be slower and potentially much longer.

GROSS PRIVATE DOMESTIC INVESTMENT

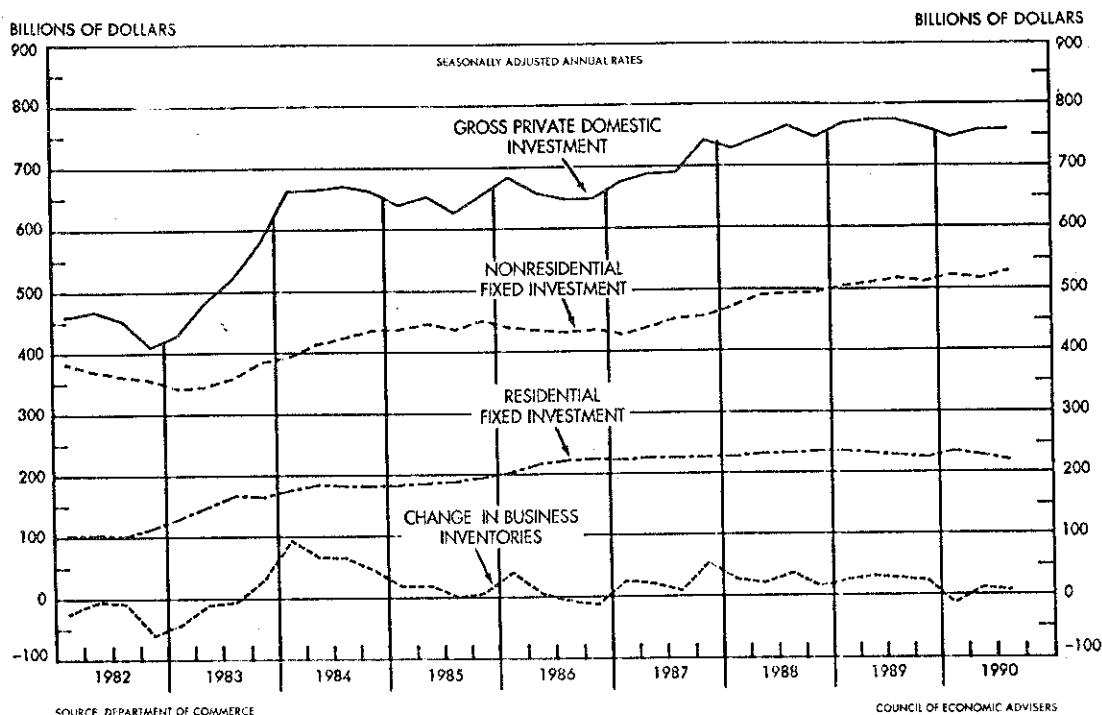

	Gross private investment	Residential fixed	Non-residential		Changes in business inventories
			Structures	Durables Equipment	
	- billions of current dollars -				
1981	516	122	139	231	24
1982	447	105	143	223	-24
1983	502	152	124	233	-7
1984	665	181	141	275	68
1985	643	189	153	290	11
1986	659	217	139	296	7
1987	700	226	134	311	28
1988	747	232	140	348	26
1989	771	231	146	366	28
1990	(760)	(230)	(148)	(372)	(10)

Evidence about what private investors think is going to happen in the US economy is provided by the decisions they make on investment. The slowdown in private investment started in the third quarter of 1989 and continued through 1990. This slowdown has been small but pervasive. Residential housing and office space is in surplus in a number of major metropolitan areas. Producer durables has been the strongest element of these national statistics. One of the strong points of the economy in this period of no growth has been control over business inventories. Most manufacturers and distributors have avoided holding large backlogs with their price depressing effects on markets. This is one reason to hope for an earlier turn around in 1991.

COMMON STOCK PRICES AND YIELDS
New York Stock Exchange, 1979-1989

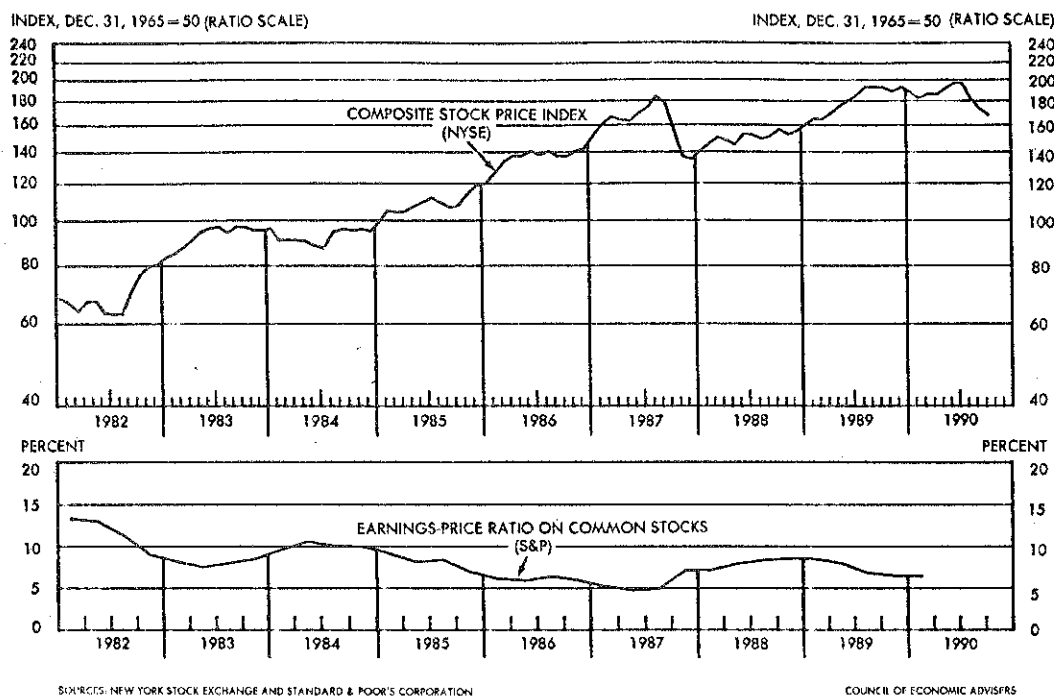

One of the most widely watched indicators of what is happening in the US economy, and people's expectations about it, is an index of prices on the New York Stock Exchange. There was an abrupt correction in market prices in October 1987 and another less striking downturn in July and August 1990. Profits before taxes have drifted downward as growth in the economy has slowed. In general it is the service industries and those producing consumer goods that are outperforming others. What happens to trade and the economies of nations outside the US may be critical to whether or not growth returns during 1991.

	<u>Profits before taxes</u>	<u>Profits after taxes</u>
	<u>- billions -</u>	
1982	\$170	\$107
1983	208	130
1984	240	146
1985	224	128
1986	222	115
1987	275	148
1988	317	181
1989	308	173
1990 I (rate)	297	167
II (rate)	299	166

INDUSTRIAL PRODUCTION

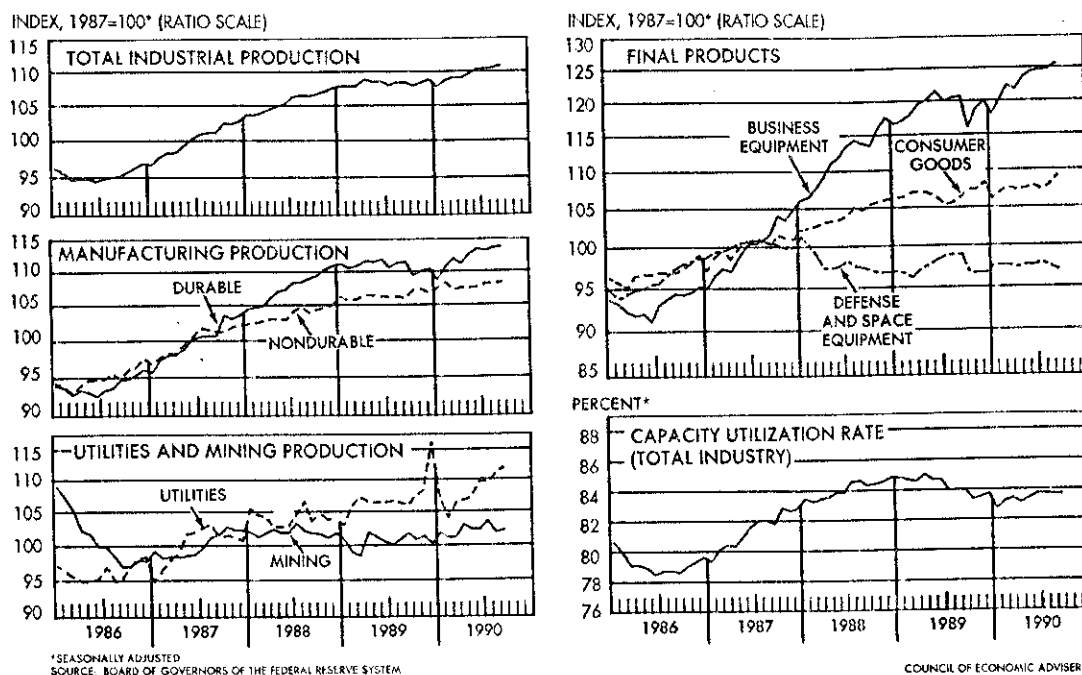

The index of industrial production prepared by the Federal Reserve System charts changes in output in the industrial sector of the US economy. A month by month comparison of the percentage change in output with year earlier index numbers shows the slow-down that occurred during late 1989 and 1990.

	Month	Percent Change from year earlier		Month	Percent Change from year earlier
1989	September	1.9	1990	March	1.1
	October	1.1		April	0.2
	November	1.1		May	1.0
	December	1.1		June	1.5
1990	January	-0.2	July	2.0	
	February	0.8	August	1.5	
			September	2.3	

As the individual charts above indicate durables and business equipment have continued to show growth. Defense and space equipment, mining, and nondurables are close to paths of no growth. There are no major downturns in these charts except for capacity utilization rates. A recession in 1990 will mean that the index numbers for consumer goods and nondurables will turn down along with the lines for defense and space equipment. Extending current trends, however, would simply suggest a stagnating economy with little or no growth.

EMPLOYMENT AND THE LABOR FORCE

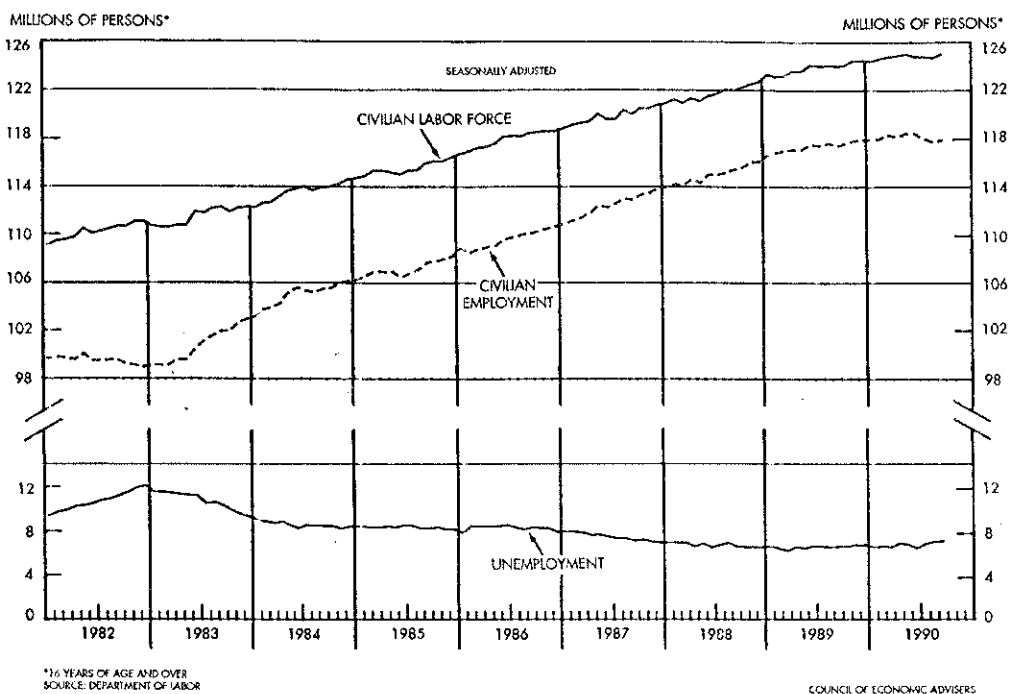

Civilian employment has grown every year since the last recession in 1982. The average level of employment for 1990 will approximate 118.0 million, a modest gain over 117.3 million in 1989. But the signs of problems in the economy are clearly evident from June 1990 onward as employment peaked at 118.4 million and has since slipped below 118 million. In general the manufacturing and industrial sector are losing jobs as the service sector holds steady or grows slowly.

Growth in the civilian labor force as charted by the Bureau of Labor Statistics has slowed as well. Thus labor force participation rates continue high even in a period of little or no economic growth. The ratio of employment to eligible population as calculated by BLS is listed below:

	<u>Percent</u>		<u>Percent</u>
1981	59.0	1986	60.7
1982	57.8	1987	61.5
1983	57.9	1988	62.3
1984	59.5	1989	63.0
1985	60.1	1990	(62.8)

With such modest growth in numbers of people coming into the labor force, problems of unemployment in a period of recession will be somewhat less than in 1982 or earlier periods.

CONSUMER AND PRODUCER PRICES

Year	Consumer Price Index		Producer Prices		
	All items	Foods	All finished goods	All intermediate goods	All crude materials
	<u>(1982-84 = 100)</u>			<u>(1982 = 100)</u>	
1981	90.9	93.6	96.1	98.6	103.0
1982	96.5	97.4	100.0	100.0	100.0
1983	99.6	99.4	101.6	100.6	101.3
1984	103.9	103.2	103.7	103.1	103.5
1985	107.6	105.6	104.7	102.7	95.8
1986	109.6	109.0	103.2	99.1	87.7
1987	113.6	113.5	105.4	101.5	93.7
1988	118.3	118.2	108.0	107.1	96.0
1989	124.0	125.1	113.6	112.0	103.1
1990	(131.5)	(132.5)	(118.8)	(114.5)	(111.0)

Sources: Department of Commerce; Council of Economic Advisers.

Concerns about inflation continue at the same time that growth in the economy has slackened. After relatively rapid rises in consumer prices early in 1990 associated with cold weather and the freeze in the South, prices stabilized in the spring and summer. The Gulf crisis has changed all that with energy prices giving a new boost to concerns about inflation at year end. The cost of labor has not been pushing consumer prices upward as much as raw materials. It is cost push that is worrying the Federal Reserve Board and the Council of Economic Advisers not demand pull.

During the middle years of the 1980s, prices of raw materials including energy helped to keep consumer prices from rising more rapidly. A comparison of the consumer price index with the three producer price index series shows how more than adequate supplies tended to hold producer prices down during much of the decade. For 1991 volatility in producer prices seems likely with the combination of crisis in the Gulf and concern about recession providing conflicting signals about what will happen next.

Major components of the Consumer Price Index are listed below with weights as of December 1989. Housing, transportation and food continue to dominate the index:

<u>Component</u>	<u>Dec. 1989 Weight (percent)</u>	<u>October 1990 (1982-84=100)</u>	<u>Percent change from October 1989 (percent)</u>
Housing	42.0	141.1	5.0
Transportation	17.1	125.8	9.9
Food	16.3	133.9	5.6
Apparel	6.1	124.8	4.6
Medical care	6.2	164.5	7.5
All other	<u>12.3</u>		
Total	100.0	133.5	6.3

SAVINGS AS A PERCENT OF DISPOSABLE INCOME

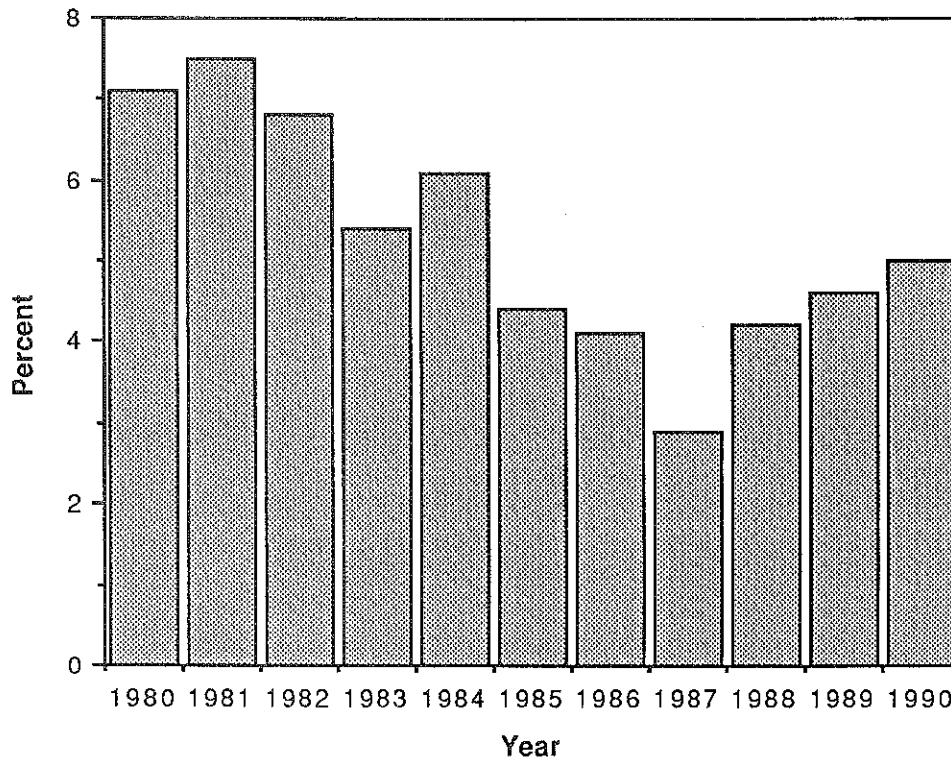

Personal savings as a percent of disposable income has begun to increase slowly again after its all time low in 1987. The rate of saving in the United States is low compared to many countries like Japan, although the method of measurement differs as well. In 1990 the rate of savings increased slightly and consumer installment credit increased less rapidly than it had in any of the past five years. Auto loans actually decreased slightly in total and as a percent of all consumer credit.

CONSUMER INSTALLMENT CREDIT

Year	Personal consumption expenditures ^{1/}	Total credit outstanding	Auto loans	Auto loans as percent of total
		- billions -		percent
December 1982	\$2108	\$324	\$124	38
December 1984	2505	443	174	39
December 1985	2713	518	210	41
December 1986	2888	573	247	43
December 1987	3102	610	266	44
December 1988	3334	665	284	43
December 1989	3554	717	291	41
December 1990	(3750)	(750)	(288)	(38)

^{1/} Annual totals.

FEDERAL FINANCE
The Federal Deficit and Debt

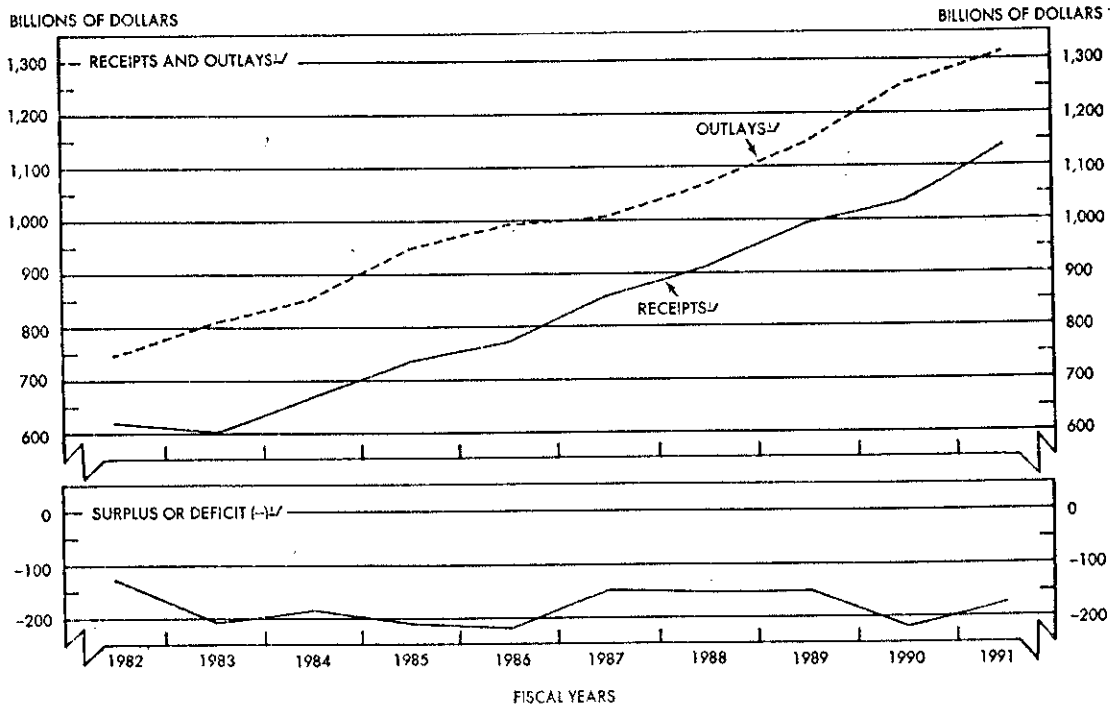

The size of the federal deficit continues to be one of the major issues of concern for the economy. The progress in reducing the deficit made in 1988 and part of 1989 has been lost. Government receipts in 1990 grew modestly while expenditures have grown more rapidly, especially in the second half of the year. The great debate over the budget during September and October 1990 reflects the severity of the problem. In a time of no economic growth and the Gulf Crisis it is difficult to see anything but a larger deficit and increased difficulty in financing it during 1991.

Fiscal Year	Government			Gross Federal debt
	Receipts	Outlays	Deficit	
- billions of dollars -				
1975	\$279	\$ 332	-53	\$ 544
1980	517	591	-74	909
1985	734	946	-212	1817
1986	769	990	-221	2120
1987	854	1004	-150	2346
1988	909	1064	-155	2601
1989	991	1143	-152	2866
1990 est. (OMB)	(1044)	(1264)	(-220)	(3206)
1991 est. (OMB)	(1135)	(1312)	(-177)	(3522)

THE U.S. TRADE DEFICIT
International Transactions, 1982-1990

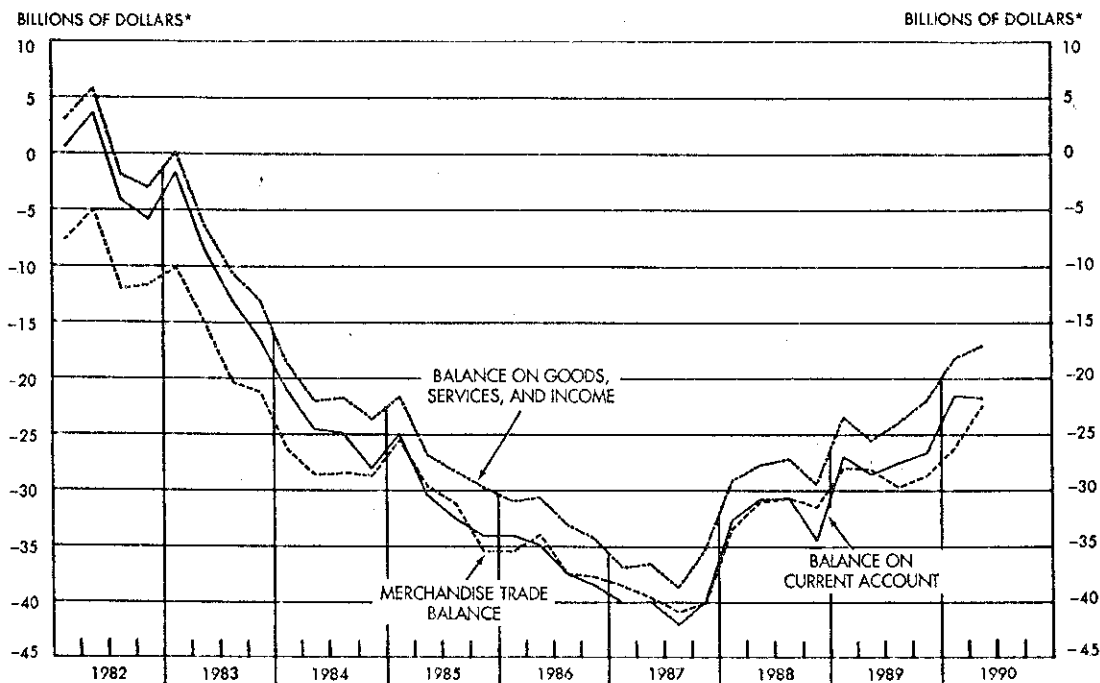

The magnitude of the trade deficit remains one of the major problems for the American economy. As long as our imports continue to exceed our exports and earnings from services and capital invested overseas by a wide margin, there is good reason for concern. We continue to consume more than we produce. We have begun to make some progress in reducing the size of this deficit. The drop in the value of the US dollar relative to the German mark and the Japanese yen may provide impetus to further narrow the trade deficit in 1991 as US exports compete more effectively in international markets.

<u>Year</u>	<u>Net balance (billions)</u>	
	<u>Goods and Services</u>	<u>Current Account</u>
1980	\$9.1	\$6.9
1982	3.9	-5.9
1984	-86.4	-99.0
1985	-106.9	-122.3
1986	-129.4	-145.4
1987	-147.7	-162.3
1988	-113.9	-128.9
1989	-95.3	-110.0
1990	(-70.0)	(-88.0)

FARM INCOME AND EXPENSES

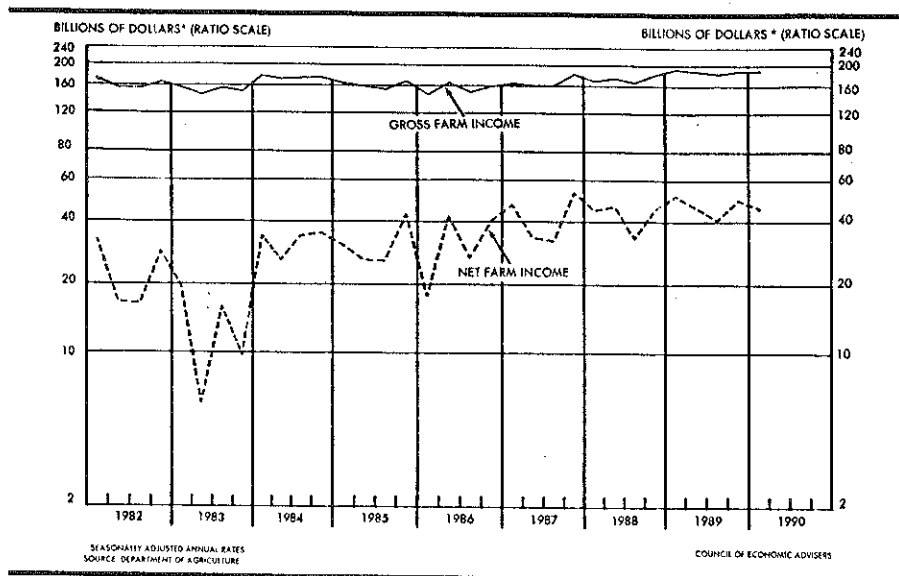

SEASONALLY ADJUSTED ANNUAL RATES
SOURCE: DEPARTMENT OF AGRICULTURE

COUNCIL OF ECONOMIC ADVISERS

Year	United States			New York net farm income
	Gross farm income	Production expenses	Net farm income	
		- billions -		millions
1981	166	139	27	401
1982	164	140	24	389
1983	153	140	13	173
1984	175	143	32	367
1985	163	132	31	501
1986	157	125	32	562
1987	169	128	41	674
1988	174	132	42	661
1989	189	143	46	807
1990	(200)	(152)	(48)	(800)

Gross and net farm income statistics have been revised modestly for the period 1984-89 as a result of additional data obtained from the 1987 Census of Agriculture. Net farm income was reduced in most of the years by 7 - 10%. Gross farm income should equal or exceed \$200 billion as a result of increased output even though grain prices fell in the second half of the year. Early expectations are that 1991 will provide smaller net returns for livestock producers, especially dairymen. The weather and yields will determine in large measure the nature of net returns from crop operations.

Estimates of net farm income in New York from the USDA have been revised upward especially for 1988 and 1989. Prices received advanced more rapidly than prices paid on dairy farms. No official estimates have been made for 1990 but it is likely that net incomes will be equal to those in 1989. In contrast net farm incomes are expected to fall in 1991, perhaps to \$500 - 600 million.

CARRYOVER STOCKS OF WHEAT AND CORN
AS PERCENT OF PRODUCTION IN U.S.

Year	Production	Ending stocks	Stocks as percent of production	Farm price per bushel
	<u>- million bushels -</u>		<u>- percent -</u>	
<u>Wheat:</u>				
1984-85	2595	1425	55	3.39
1985-86	2424	1905	79	3.08
1986-87	2091	1821	87	2.42
1987-88	2108	1261	60	2.57
1988-89	1812	702	38	3.72
1989-90	2037	536	26	3.72
1990-91	(2744)	(946)	(34)	(2.70)
<u>Corn:</u>				
1984-85	7674	1648	21	2.63
1985-86	8875	4040	46	2.23
1986-87	8226	4882	59	1.50
1987-88	7131	4259	60	1.94
1988-89	4929	1930	39	2.54
1989-90	7527	1344	18	2.36
1990-91	(8022)	(1236)	(15)	(2.40)

Source: USDA.

Carryover stocks of wheat in the US are once again increasing to over 900 million bushels, a major increase compared to 1988 and 1989, but much smaller than stocks in the mid-1980s. In contrast ending corn stocks for 1990-91 are expected to be at the lowest level they have been since 1983-84. This has narrowed the spread between wheat and corn prices dramatically in great contrast to one year ago when they were more than \$1.00 per bushel.

WORLD PRODUCTION AND USE OF GRAINS
USDA Estimates, 1982-89

Production Year	Production	Utilization	Exports	Ending stocks	Stocks as percent of use
	<u>- million metric tons -</u>				<u>percent</u>
1982-83	1548	1505	200	351	23
1985-86	1662	1594	205	430	27
1986-87	1684	1655	212	459	28
1987-88	1606	1665	222	401	24
1988-89	1562	1658	231	312	18
1989-90	1677	1697	231	292	17
1990-91	(1758)	(1735)	(220)	(315)	(18)

World production of grain increased by nearly 5% in 1990 reducing pressure on world stocks of wheat and food grains. Ending stocks are expected to increase modestly over year earlier levels. World prices have fallen substantially in response to increased supplies and the use of export subsidies by the EC and to a lesser extent by the US.

FARM PROGRAMS AND PRICE SUPPORTS
United States, 1985-86 to 1991-92

Year	Target price	Effective loan rate	Market price	Deficiency payment	Setaside requirement
		- dollars per bushel -			percent
<u>Wheat:</u>					
1985-86	4.38	3.30	3.08	1.08	20
1986-87	4.38	2.40	2.42	1.98	22.5
1987-88	4.38	2.28	2.57	1.81	27.5
1988-89	4.23	2.21	3.72	.69	27.5
1989-90	4.10	2.06	3.72	.32	10
1990-91	4.00	1.95	(2.70)	(1.30)	5
1991-92	4.00	(2.44)			
<u>Corn:</u>					
1985-86	3.03	2.55	2.23	.48	10
1986-87	3.03	1.92	1.50	1.11	17.5
1987-88	3.03	1.82	1.94	1.09	20
1988-89	2.93	1.77	2.54	.39	20
1989-90	2.84	1.65	2.36	.46	10
1990-91	2.75	1.57	(2.40)	(.45)	10
1991-92	2.75	(1.76)*			

*Cannot be lower than these rates except when 80% of average of market prices in previous 5 years is less.

New omnibus legislation entitled The Food, Agriculture, Conservation, and Trade Act of 1990 (FACT Act of 1990), was passed and signed in October 1990. Many compromises were made in obtaining agreement between the House and Senate versions and with the Secretary of Agriculture, acting for the Office of the President. The new bill is similar in format to the old one with the commodity titles treated first. Target prices are maintained at 1990 levels until 1995. The effective loan rates have been tied to the previous 5 year average of market prices excluding the high and low year.

A 15% "Triple Base Plan" has been introduced for 1991-95. Details will be announced by ASCS before March 1991. The intent is to increase planting flexibility. Program participants who elect "triple base" must reduce the acreage eligible for deficiency payments by 15% in addition to the land set aside in the Acreage Reduction Program. On triple base acreage, producers may plant any program crop such as wheat or corn, oilseeds, and all non-program crops except fruits and vegetables. Crops planted on these acres will not be eligible for deficiency payments but are eligible for nonrecourse loans.

United States consumers spent \$423 billion for foods originating on U.S. farms in 1989. About 61 percent of those expenditures were in retail grocery stores on food for at home use. The remaining 39 percent represented the retail value of food served by public eating places, hospitals, schools and other institutions. About 24 percent of the \$423 billion (\$103 billion) went back to farmers. The remaining \$320 billion was the marketing bill (see Figure 1).

The marketing bill, the difference between what consumers spent on food and the farm value of the food, rose 6 percent in 1989, mainly due to higher prices of most inputs and the greater use of some inputs, particularly labor. Much of the increased cost to the consumer is reflected by the increased value added to foods. Microwavable, shelf stable, convenience packaging, and hot prepared foods are examples of value-added food that the consumer is willing to pay more for.

FIGURE 1

Distribution of food expenditures

Marketing bill dominates farm value of food expenditures.

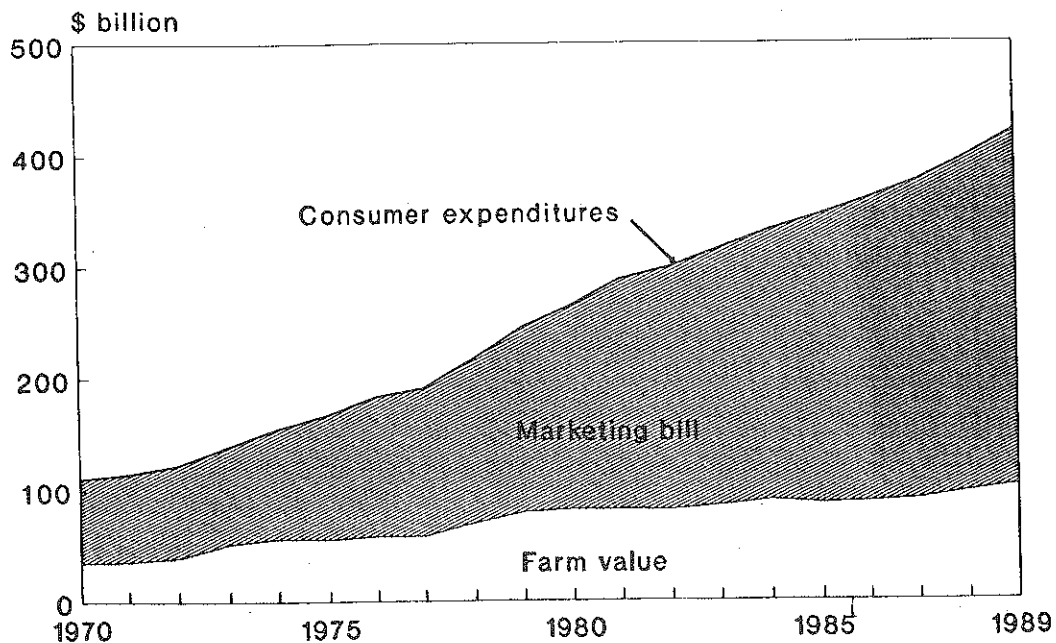

1989 preliminary. Data for foods of U.S. farm origin purchased by or for consumers for consumption both at home and away from home.

Source: USDA, ERS, Agricultural Economic Report Number 636

Higher labor costs accounted for about 48 percent of last year's increase in the marketing bill, about the same proportion as in 1988. Much of the remaining increase in the marketing bill occurred in food packaging materials and other costs, including advertising and promotion, taxes and insurance, and professional services.

Small increases in transportation and energy costs and greater industry efforts to control labor and other costs have slowed the rise of the marketing bill in recent years. Nevertheless, marketing costs continued to be the most persistent source of rising consumer food expenditures.

What the Marketing Bill Bought

Costs of the basic functions performed by the food industry -- processing, wholesaling, transporting and retailing -- are different for food purchased in food stores than for meals and snacks purchased away from home (see Figure 2). These shares have remained fairly constant over time.

FIGURE 2

Marketing functions of the food dollar

Processing costs are the largest marketing function for food eaten at home.

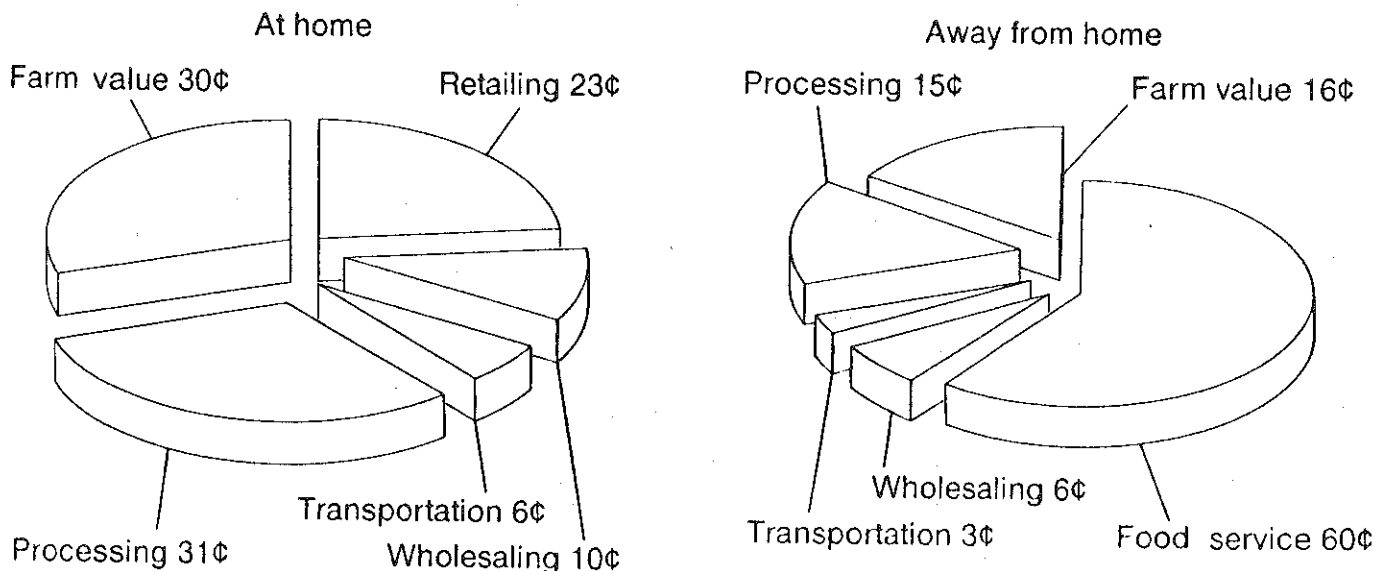

1989 data.

Source: USDA, ERS, Agricultural Economic Report Number 636

The Food Dollar

Another way of looking at the distribution of the marketing bill is to consider what part of the consumer food dollar goes to each input. Labor is the largest part of the marketing bill, amounting to 35 percent of food expenditures. Food containers and packaging materials, the second largest food marketing cost, are about 8.5 percent of total food expenditures. Packaging costs in 1989 rose 8 percent above 1988 levels, partly reflecting greater use of plastics and other packaging materials in the industry (see Figure 3).

Farm Value

The farm value of foods in the market basket averaged 6.7 percent higher in 1989, largely due to higher poultry, egg and milk prices (see Table 1).

TABLE 1
Price changes for market basket of foods 1/

Item	1984	1985	1986	1987	1988	1989 2/
	<u>Annual percentage change</u>					
Market basket:						
Retail price	3.9	1.2	2.1	5.0	4.4	7.0
Farm value	6.3	-7.1	-1.4	2.3	3.8	6.7
Farm-to-retail spread	2.8	5.6	3.9	6.1	4.7	7.1
Meat products:						
Retail price	.3	-.9	3.1	7.5	2.4	4.0
Farm value	2.4	-8.2	3.3	7.3	-1.6	3.8
Farm-to-retail spread	-1.7	6.4	2.9	7.7	5.8	4.2
Dairy products:						
Retail price	1.3	1.9	.1	2.5	2.4	6.6
Farm value	-1.2	-4.1	-2.8	.8	-2.9	9.3
Farm-to-retail spread	3.7	7.1	2.5	3.7	6.1	4.9
Poultry:						
Retail price	10.6	-1.0	7.5	-1.4	7.2	9.9
Farm value	16.8	-6.0	8.7	-18.5	17.5	7.2
Farm-to-retail spread	3.6	5.4	6.3	18.4	-1.1	12.4
Eggs:						
Retail price	11.7	-16.6	6.8	-5.9	2.3	26.6
Farm value	11.2	-22.2	7.8	-16.9	-.2	40.5
Farm-to-retail spread	12.9	-6.5	5.6	11.2	5.0	11.2
Cereal and bakery products:						
Retail price	4.3	3.8	2.8	3.5	6.4	8.4
Farm value	1.7	-8.4	-19.1	-7.0	30.6	9.8
Farm-to-retail spread	4.8	5.5	5.4	4.5	4.4	8.3
Fresh fruit:						
Retail price	13.6	11.1	1.7	12.6	7.2	6.4
Farm value	41.1	-2.6	-6.3	9.7	2.3	-6.5
Farm-to-retail spread	3.4	18.0	5.0	13.8	8.9	10.8
Fresh vegetables:						
Retail price	10.9	-4.3	4.1	12.9	6.3	10.7
Farm value	11.8	-14.0	-3.3	24.4	-3.5	17.2
Farm-to-retail spread	10.5	-.6	7.3	8.3	10.7	8.2
Processed fruit and vegetables:						
Retail price	6.0	2.6	-1.6	3.5	7.9	6.3
Farm value	14.3	10.2	-13.8	9.5	23.0	-1.5
Farm-to-retail spread	3.4	.3	2.6	1.8	3.2	9.2
Fats and oils:						
Retail price	9.4	2.2	-2.2	1.5	4.6	7.2
Farm value	29.2	-16.1	-27.0	-2.8	38.5	-7.1
Farm-to-retail spread	2.5	10.4	6.3	2.6	-3.0	11.7
Other prepared food:						
Retail price	3.0	3.3	2.6	4.2	3.7	6.4
Farm value	3.7	-6.7	4.7	2.3	4.8	9.5
Farm-to-retail spread	2.9	4.9	2.3	4.5	3.5	5.9

1/ Changes in retail prices are from the Consumer Price Index published by the U.S. Department of Labor, Bureau of Labor Statistics. The farm value is based on prices received by farmers for commodities equivalent to food at retail. The spread between the retail price and farm value represents charges for processing and marketing. 2/ Preliminary.

Source: USDA, ERS, Agricultural Economic Report Number 636

FIGURE 3

What a dollar spent on food paid for in 1989

About half of the marketing bill pays labor costs.

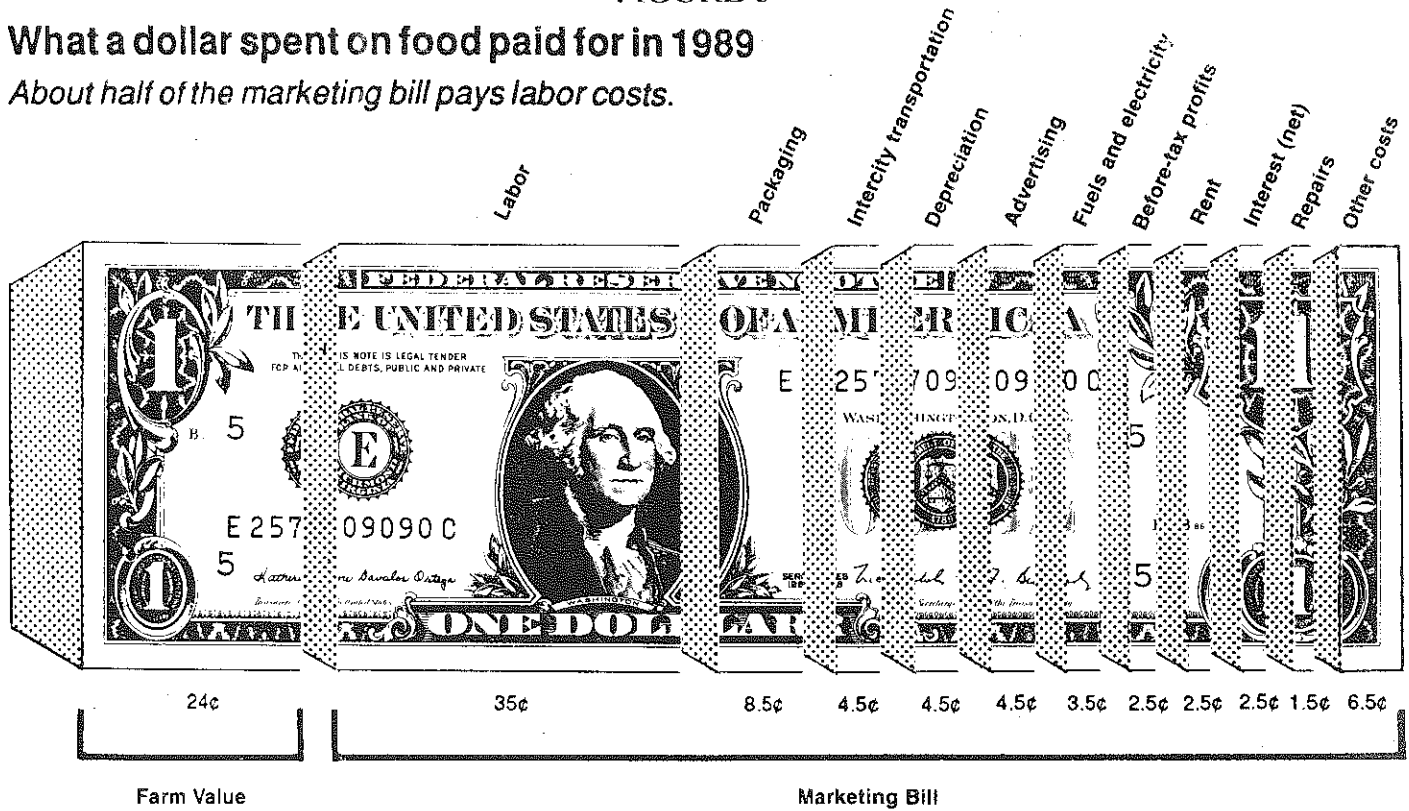

Includes food eaten at home and away from home. Other costs include property taxes and insurance, accounting and professional services, promotion, bad debts, and many miscellaneous items.

FIGURE 4

Price components of the market basket

Price spread in 1989 continued its upward trend.

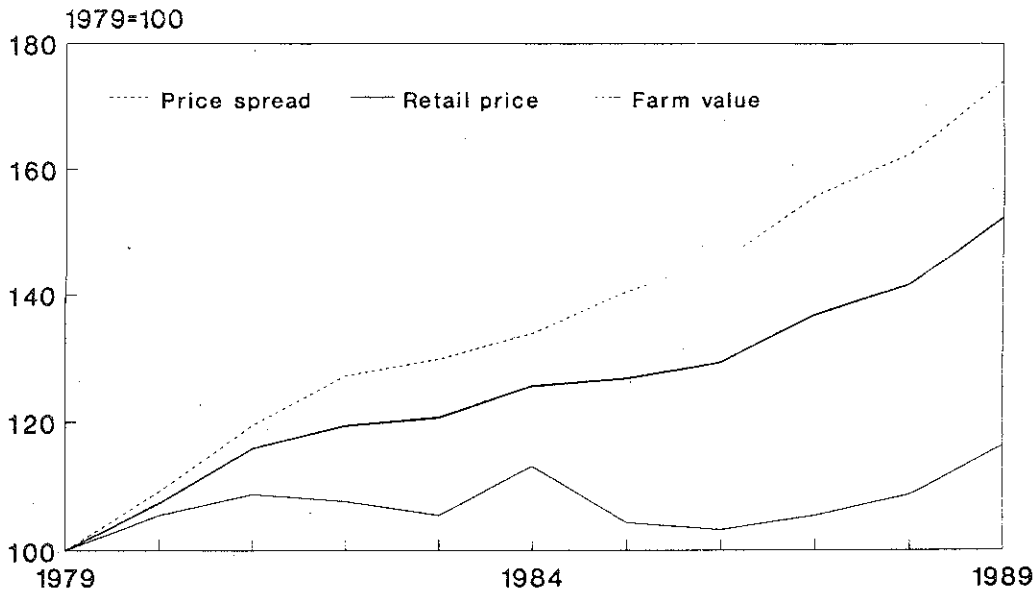

Retail prices based on the CPI for food eaten at home. Farm value based on prices received by farmers. Price spread represents processing and distributing charges.

Source: USDA, ERS, Agricultural Economic Report Number 636

Farm-to-Retail Price Spread

The farm-to-retail price spread for the market basket of foods averaged 7.1 percent higher in 1989, a larger increase than 1988. This increase accounted for 71 percent of the 7 percent rise in the retail cost of the market basket. The increase in the spread reflected higher prices of inputs, such as labor and packaging within the food industry, and greater use of some inputs per unit of output.

The hours of labor used in food retailing have been increased to provide greater service and more prepared foods. Development of new products, such as microwavable foods, has increased use of packaging materials. Increased spending on advertising and promotion of branded foods has also added to costs.

Summary

During the period 1980-1989 retail prices of the items in the market basket of food rose 42 percent, while the farm value of these items rose only 11 percent. This is reflected in the farm-to-retail price spread for this period which rose 60 percent (see Figure 4). Increases in the farm-to-retail spread usually were close to the general inflation rate on a year-to-year basis, reflecting the link between the inputs of the food industry and the economy.

The farm value of all food represented 24 percent of consumer expenditures for farm foods in 1989, unchanged from the previous two years. For food eaten away from home, farm value was 16 percent of expenditures, compared with about 30 percent for farm foods purchased in food stores for at-home consumption (see Table 2). The farm value for all food was stable in 1988 and 1989 because the increase in farm value nearly matched the rise in retail prices. This stability contradicts the long-term trend. The farm value share of the retail cost of food averaged 38-40 percent most years during the 1960s and 1970s, and trended sharply down from 1979 to 1987 because farm prices did not increase most years. Retail prices continued to rise through this period, however, reflecting higher processing and marketing costs.

TABLE 2

Indexes of retail price, farm value, and the farm-to-retail price spread and farm value as a share of retail price 1/

Year	Retail price	Farm value	Farm-to-retail spread	Farm value share of retail price
	-----1982-84=100-----			Percent
1950	30	40	25	47
1951	33	46	26	49
1952	34	44	28	47
1953	32	41	28	45
1954	32	39	28	43
1955	31	36	29	41
1956	32	36	29	40
1957	33	37	30	40
1958	35	40	32	41
1959	34	37	32	39
1960	34	38	32	39
1961	34	37	33	39
1962	34	38	33	39
1963	34	36	33	38
1964	34	36	34	36
1965	35	40	33	38
1966	37	43	34	39
1967	37	40	35	39
1968	38	42	36	38
1969	40	46	37	39
1970	42	46	40	37
1971	43	46	41	37
1972	45	50	42	38
1973	52	68	45	44
1974	60	73	53	42
1975	64	76	58	40
1976	65	72	61	38
1977	66	72	63	37
1978	74	83	68	38
1979	82	92	77	38
1980	88	97	84	37
1981	95	100	92	36
1982	98	99	98	35
1983	99	97	100	34
1984	103	104	103	35
1985	104	96	108	32
1986	106	95	112	31
1987	112	97	120	30
1988	116	100	125	30
1989 <u>2/</u>	125	107	134	30

1/ For a market basket of foods bought in foodstores in a base period, currently 1982-84. The retail price index is derived from data from the U.S. Department of Labor, Bureau of Labor Statistics. Farm value is based on prices received by farmers for commodities. The spread between the retail price and farm value represents charges for processing and marketing.
2/ Preliminary.

United States Farm Balance Sheet
Current Dollars, December 31
Including Operator Households

Item	1970	1975	1980	1985	1987	1988	1989
---billion dollars---							
<i>Assets</i>							
Real Estate	209.2	421.0	850.1	650.0	633.5	665.8	688.1
Livestock	20.2	29.3	60.6	46.2	58.0	65.5	69.7
Machinery	31.1	62.1	99.3	88.3	84.5	85.7	88.2
Crops & Supplies ^a	7.9	21.1	33.0	24.1	21.2	26.5	26.3
Household	9.4	11.7	19.4	27.8	32.9	37.0	41.3
Financial Assets	15.3	18.4	20.0	25.0	31.4	32.9	32.5
Coop. Invest.	6.8	11.9	19.2	24.3	25.3	25.1	26.1
Total	300.1	575.4	1101.6	885.8	886.8	938.5	972.2
<i>Liabilities and Equity</i>							
RE Debt	27.4	49.9	97.5	105.7	87.7	82.9	80.5
NonRE Debt ^b	20.4	41.6	81.2 ^b	82.2	66.0	65.6	65.5
Total	47.8	91.5	178.7	187.9	153.7	148.5	146.0
Owner Equity	252.3	484.0	922.9	697.9	733.1	790.0	826.2
Total	300.1	575.4	1101.6	885.8	886.8	938.5	972.2
% Equity	84	84	84	79	83	84	85

Changes in Structure, U.S. Farm Balance Sheet
Current Dollars, 1970-89

Item	1970	1975	1980	1985	1987	1988	1989
---percent of total---							
<i>Assets</i>							
Real Estate	70	73	77	73	71	71	71
Livestock	7	5	6	5	7	7	7
Machinery	10	11	9	10	10	9	9
All Other ^a	13	11	8	12	12	13	13
Total	100	100	100	100	100	100	100
<i>Liabilities</i>							
RE Debt	57	55	55	56	57	56	55
NonRE Debt ^b	43	45	45	44	43	44	45
Total	100	100	100	100	100	100	100

^a Excludes crops under CCC loan.

^b Excludes CCC loans.

Source: Economic Research Service, USDA.

Distribution of United States Farm Debt by Lender
Current Dollars, December 31
Including Farm Households

Item	1970	1975	1980	1985	1987	1988	1989
---billion dollars---							
<i>Real Estate</i>							
Farm Credit System	6.1	16.0	36.2	44.6	32.6	30.3	28.5
Individuals & Others	10.2	17.3	30.2	27.2	20.6	18.0	16.7
Commercial Banks	3.3	6.3	8.6	11.4	14.5	15.4	17.0
Farmers Home Admin.	2.0	3.4	8.2	10.4	10.1	9.6	8.7
Insurance Companies	5.8	6.7	12.9	11.8	9.9	9.6	9.6
CCC - Storage	<u>.0</u>	<u>.2</u>	<u>1.4</u>	<u>.3</u>	<u>a</u>	<u>a</u>	<u>a</u>
Total	27.4	49.9	97.5	105.7	87.7	82.9	80.5
<i>Nonreal Estate^b</i>							
Commercial Banks	9.7	20.2	31.6	35.5	29.0	29.8	30.8
Farmers Home Admin.	.8	1.8	11.4	16.7	16.1	14.7	12.3
Merchants & Dealers	5.9	8.5	17.7	15.4	11.1	12.0	12.5
Farm Credit System	<u>4.0</u>	<u>11.1</u>	<u>20.5</u>	<u>14.6</u>	<u>9.8</u>	<u>9.1</u>	<u>9.9</u>
Total	23.1	42.0	81.2	82.2	66.0	65.5	65.5

United States Farm Debt
Market Share by Lender
Current Dollars, December 31

Item	1970	1975	1980	1985	1987	1988	1989
---percent of total---							
Farm Credit System	21	30	32	32	28	27	26
Commercial Banks	27	29	23	25	28	30	33
Farmers Home Adm.	6	6	11	14	17	16	14
Ins. Companies	12	7	7	6	6	7	7
Indiv. & Merchants	<u>34</u>	<u>28</u>	<u>27</u>	<u>23</u>	<u>21</u>	<u>20</u>	<u>20</u>
Total ^b	100	100	100	100	100	100	100

^a Less than .05 billion.

^b Excludes CCC crop loans.

Source: ERS, USDA.

New York Farm Balance Sheet
Current Dollars, December 31
Including Farm Households

Item	1970	1975	1980	1985	1987	1988	1989
---million dollars---							
<i>Assets</i>							
Real Estate	3157	5862	7266	7671	8639	9052	8753
Livestock	536	653	1527	983	1113	1151	1291
Machinery	859	1410	2124	1997	1926	1919	1902
Crops & Supplies ^a	212	396	579	516	486	521	518
Household	289	306	313	1042	1229	1382	1545
Financial Assets	342	353	378	471	583	600	568
Coop. Investments	<u>186</u>	<u>313</u>	<u>455</u>	<u>493</u>	<u>495</u>	<u>472</u>	<u>493</u>
Total	5581	9293	12642	13173	14471	15096	15070
<i>Liabilities & Equity</i>							
Real Estate Debt	430	758	1217	1225	1045	1014	1117
Nonreal Estate Debt ^b	<u>435</u>	<u>787</u>	<u>1661</u>	<u>1561</u>	<u>1378</u>	<u>1234</u>	<u>1246</u>
Total Debt	865	1545	2878	2786	2423	2248	2363
Equity	<u>4716</u>	<u>7748</u>	<u>9764</u>	<u>10387</u>	<u>12048</u>	<u>12848</u>	<u>12707</u>
Total	5581	9293	12642	13173	14471	15096	15070
% Equity	85	83	77	79	83	85	84

Changes in Structure, New York Farm Balance Sheet
Current Dollars, December 31, 1970-89

Item	1970	1975	1980	1985	1987	1988	1989
---percent of total---							
<i>Assets</i>							
Real Estate	57	63	57	58	60	60	58
Livestock	10	7	12	8	8	7	8
Machinery	15	15	17	15	13	13	13
All Other	<u>18</u>	<u>15</u>	<u>14</u>	<u>19</u>	<u>19</u>	<u>20</u>	<u>21</u>
Total ^a	100	100	100	100	100	100	100
<i>Liabilities</i>							
Real Estate Debt	50	49	42	44	43	45	47
Nonreal Estate Debt ^b	<u>50</u>	<u>51</u>	<u>58</u>	<u>56</u>	<u>57</u>	<u>55</u>	<u>53</u>
Total	100	100	100	100	100	100	100

^a Excludes crops under CCC loan.

^b Excludes CCC loans. All FmHA Emergency Loans are classified as nonreal estate. Total includes some nonreal estate loans made by New York City institutions to businesses outside New York State.

Source: ERS, USDA.

New York Farm Debt by Lender
Current Dollars, December 31
Includes Farm Households

	1970	1975	1980	1985	1987	1988	1989
---million dollars---							
<i>Real Estate</i>							
Farm Credit System	120	315	432	489	396	430	462
Individuals & Others	174	257	439	396	300	262	247
Commercial Banks	85	121	126	96	133	111	220
Farmers Home Admin.	42	55	170	209	197	190	177
Insurance Companies	9	9	31	29	18	21	11
CCC - Storage	<u>a</u>	<u>1</u>	<u>19</u>	<u>6</u>	<u>1</u>	<u>a</u>	<u>a</u>
Total	430	758	1217	1225	1045	1014	1117
<i>Nonreal Estate</i>							
Commercial Banks	164	281	665	629	589	428	402
Farmers Home Admin.	29	42	323	326	304	282	264
Farm Credit System	145	293	341	344	295	321	369
Merchants & Dealers	<u>96</u>	<u>171</u>	<u>332</u>	<u>262</u>	<u>189</u>	<u>203</u>	<u>212</u>
Total	435	787	1661	1561	1378	1234	1246

^a Less than .5.

New York State Farm Debt
Market Share by Lender
Current Dollars, December 31

Lender	1970	1975	1980	1985	1987	1988	1989
---percent of total farm debt---							
Commercial Banks	29	26	28	26	30	24	26
Farm Credit System	31	39	27	30	28	33	35
Farmers Home Admin.	8	6	17	19	21	21	19
Insurance Companies	1	1	1	1	1	1	1
Indiv. & Merchants	<u>31</u>	<u>28</u>	<u>27</u>	<u>24</u>	<u>20</u>	<u>21</u>	<u>19</u>
Total	100	100	100	100	100	100	100

Source: ERS, USDA.

Nonaccrual Farm Loans
Farm Credit System, December 31

Year	Total System	Springfield District
---percent of loan volume---		
1984 ^a	2.3	1.1
1985 ^a	7.7	.8
1986 ^a	12.9	2.4
1987 ^a	11.1	1.1
1988	8.0	0.6
1989	6.3	0.4

^a Weighted average for PCA and FLB's for 1984-87.

Source: *Annual FCA and Quarterly FCCA Reports.*

Nonaccrual Farm Nonreal Estate Loans
Commercial Banks, December 31

Year	United States
-percent of loan volume-	
1983	2.7
1984	4.1
1985	6.1
1986	5.9
1987	4.2
1988	2.9
1989	1.9
1990 (June 30)	1.8

Source: *Agricultural Finance Databook. Reports of Condition and Income.*

Delinquent Major Farm Program Loans
Farmers Home Administration

Date	Farm Ownership		Operating Loans		Emergency Loans		Economic Emergency		Soil and Water	
	U.S.	N.Y.	U.S.	N.Y.	U.S.	N.Y.	U.S.	N.Y.	U.S.	N.Y.
---percent of loan volume---										
9/30/85	5	5	13	10	37	25	23	19	11	7
9/30/86	5	5	16	12	41	31	27	25	12	9
9/30/87	6	7	19	14	45	34	31	34	14	10
9/30/88	8	9	25	19	57	38	42	45	20	12
6/30/89	10	10	29	21	63	43	47	52	23	14

Source: *FmHA Report Code 616.*

Annual Long Term Interest Rates

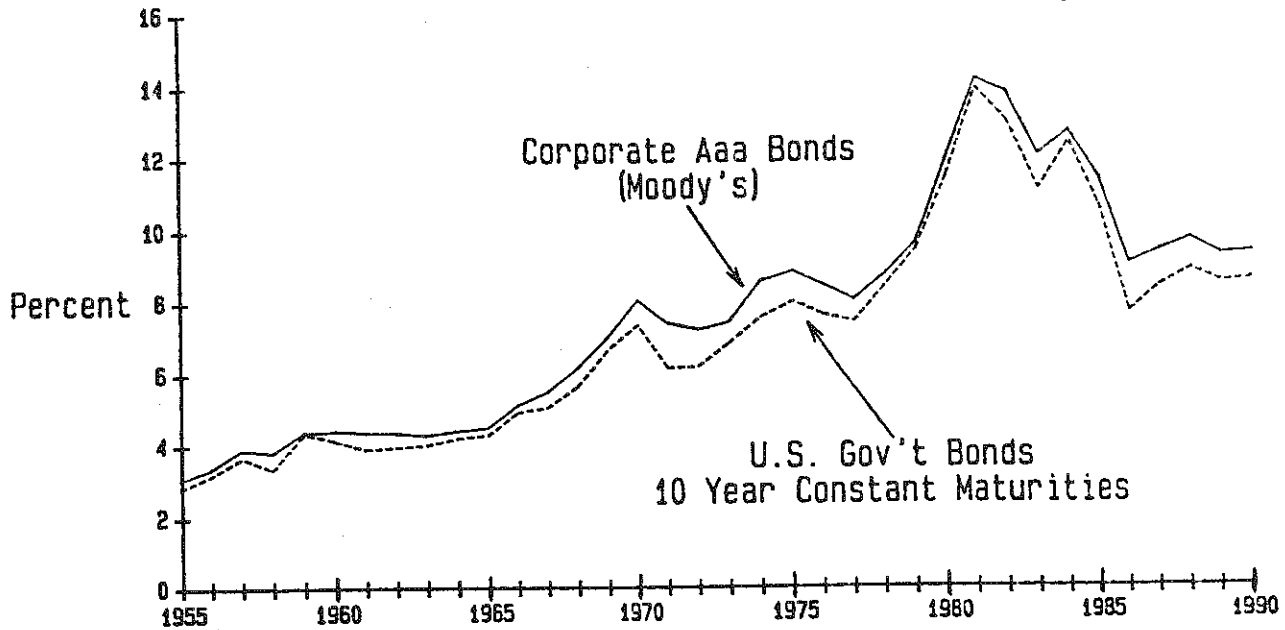

Monthly Long Term Interest Rates

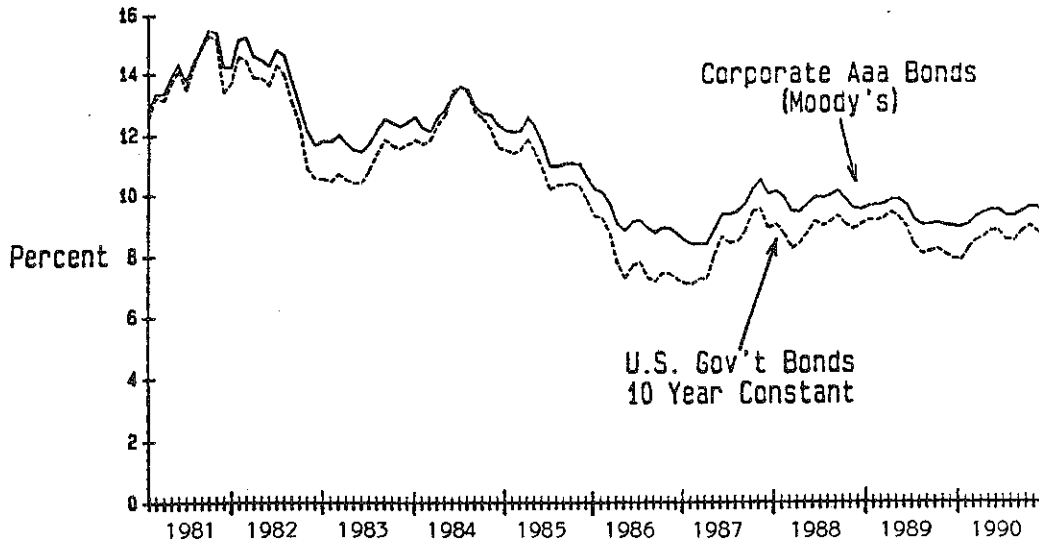

U.S. Government Bonds
10 Year Constant Maturities

	1989	1990
Jan	9.09	8.21
Feb	9.17	8.47
Mar	9.36	8.59
Apr	9.18	8.79
May	8.86	8.76
Jun	8.28	8.48
Jul	8.02	8.47
Aug	8.11	8.75
Sep	8.19	8.94
Oct	8.01	8.75
Nov	7.87	8.55
Dec	7.84	

Annual Average Short Term Interest Rates

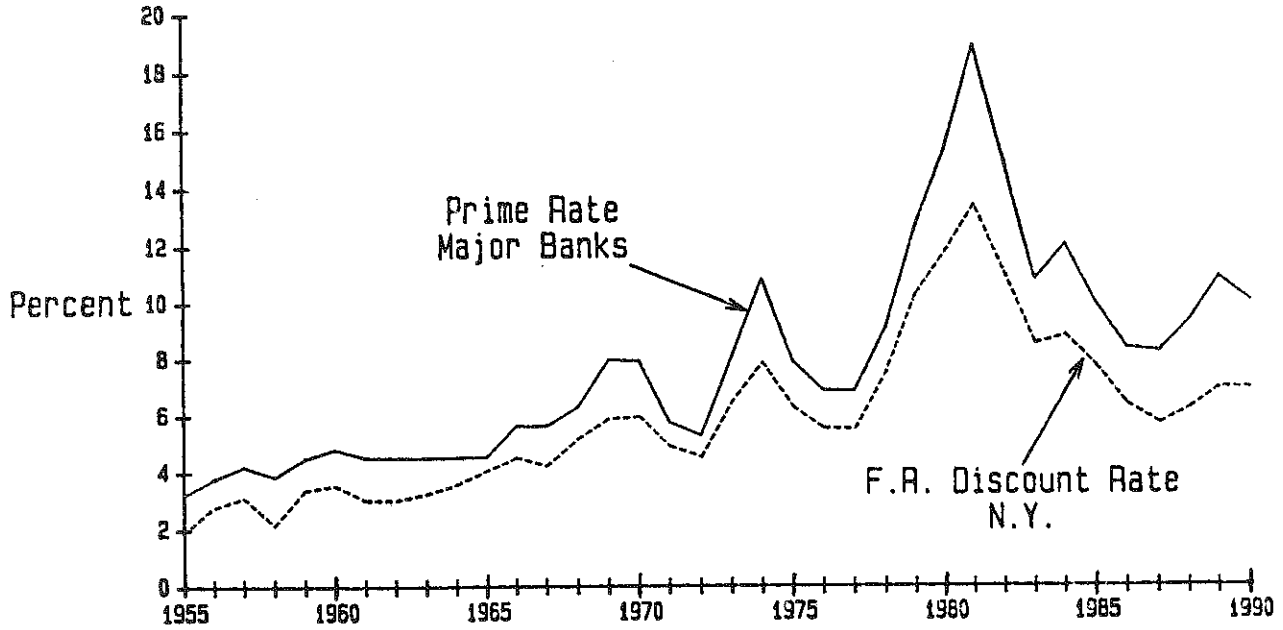

Monthly Short Term Interest Rates

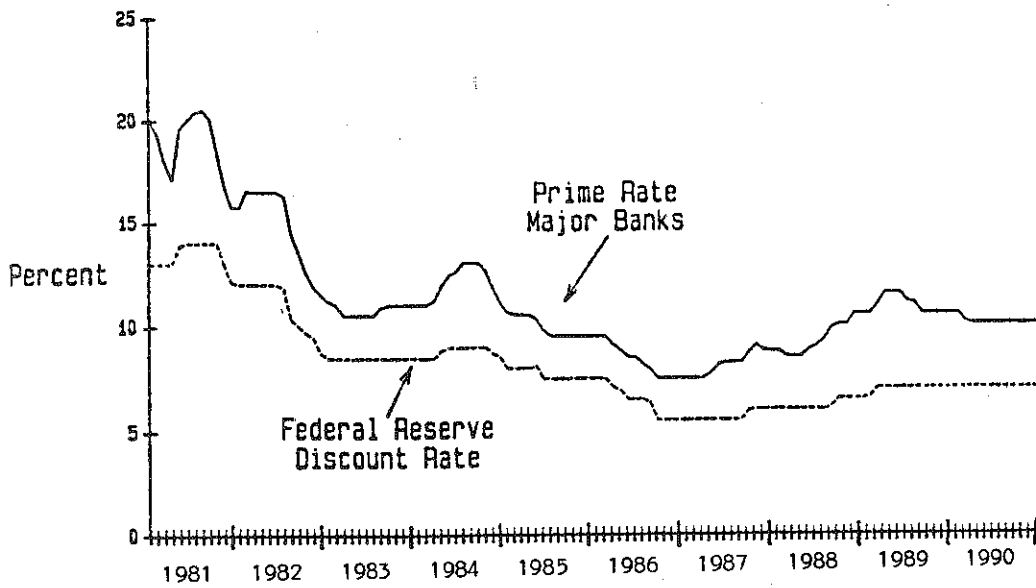

	Prime Rate Major Banks	
	1989	1990
Jan	10.50	10.11
Feb	10.93	10.00
Mar	11.50	10.00
Apr	11.50	10.00
May	11.50	10.00
Jun	11.07	10.00
Jul	10.98	10.00
Aug	10.50	10.00
Sep	10.50	10.00
Oct	10.50	10.00
Nov	10.50	10.00
Dec	10.50	

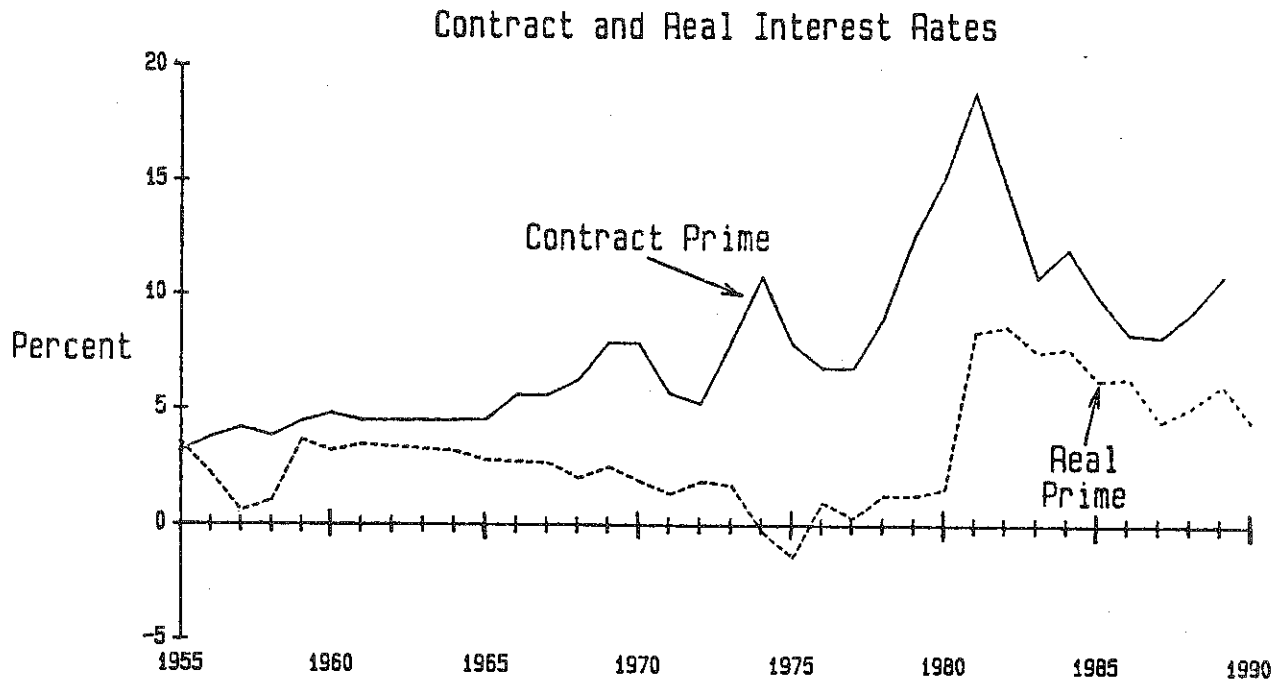

The level of interest rates in the coming months is even more uncertain than is normally the case. Most forecasters believe the U.S. economy is a period of very slow growth or a recession. This reduced rate of growth would be expected to reduce the demand for funds and, thus, reduce interest rates. In the short run, into early 1991, this will likely occur. Rates should continue their modest decline into early 1991 with a rate drop in the range of 1/4 to 3/4 percentage points.

Many factors could react an important influence on rates during most of 1991. A resurgence of inflation could force rates higher. The current high oil prices, and the prospect for continued high oil prices if the current hostilities in Persian Gulf continue, will have both a direct and indirect effect on inflation rates. Substantial increases in inflation, and thus interest rates, could result.

The budget deficit continues to be large. The deficit reduction package was a drop in the bucket. Financing this deficit provides upward pressure on interest rates. The degree of upward pressure could be increased if foreigners decide to invest less in the U.S. because they are investing more in their own countries (Germany) or as they respond to the declining value of the dollar and higher rates in their own country or elsewhere.

As expected last year at this time, farm level interest rates declined slightly in early 1990 and remained relatively constant for the rest of the year until the declining economy resulted in some softening of rates very late in the year. In 1991 rates are expected to continue decline slightly very early in the year, but will likely return to 1990 or higher levels by mid year.

CHANGE IN FARM REAL ESTATE VALUES, UNITED STATES

Percent Change In U.S. Farmland Value Per Acre: February 1, 1989 to January 1, 1990

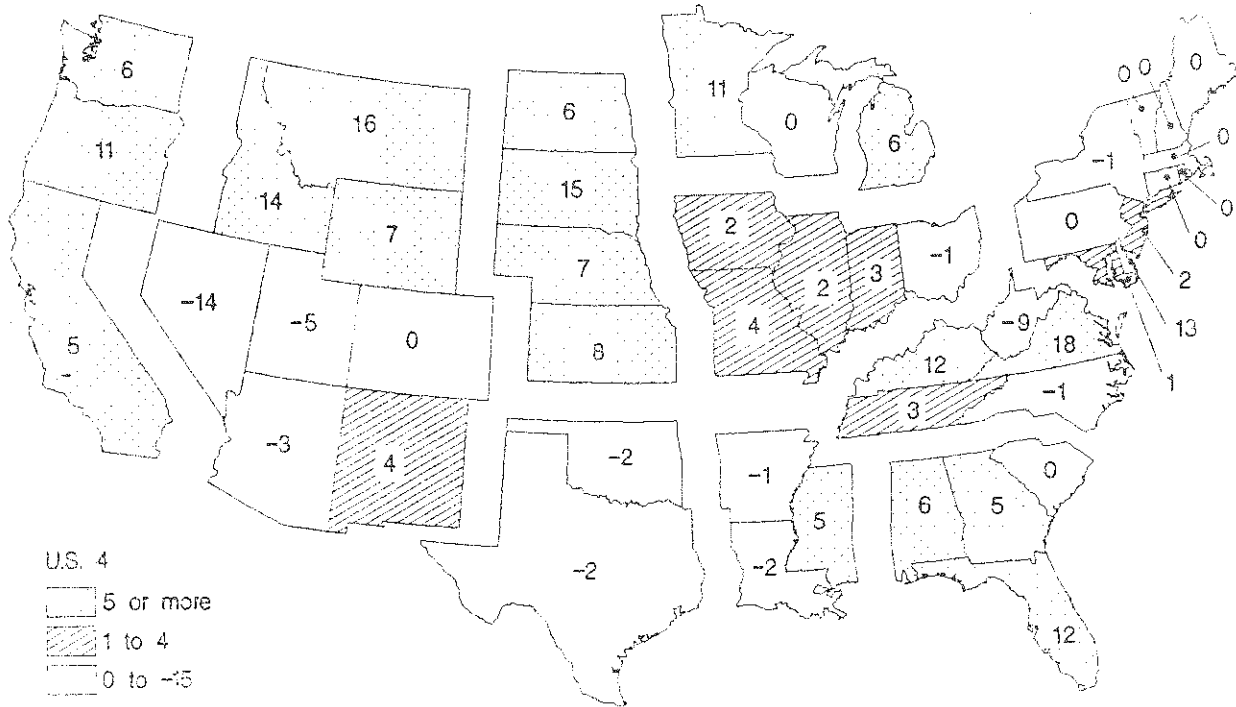

Changes In Per Acre Nominal U.S. Farmland Values

% change from year earlier

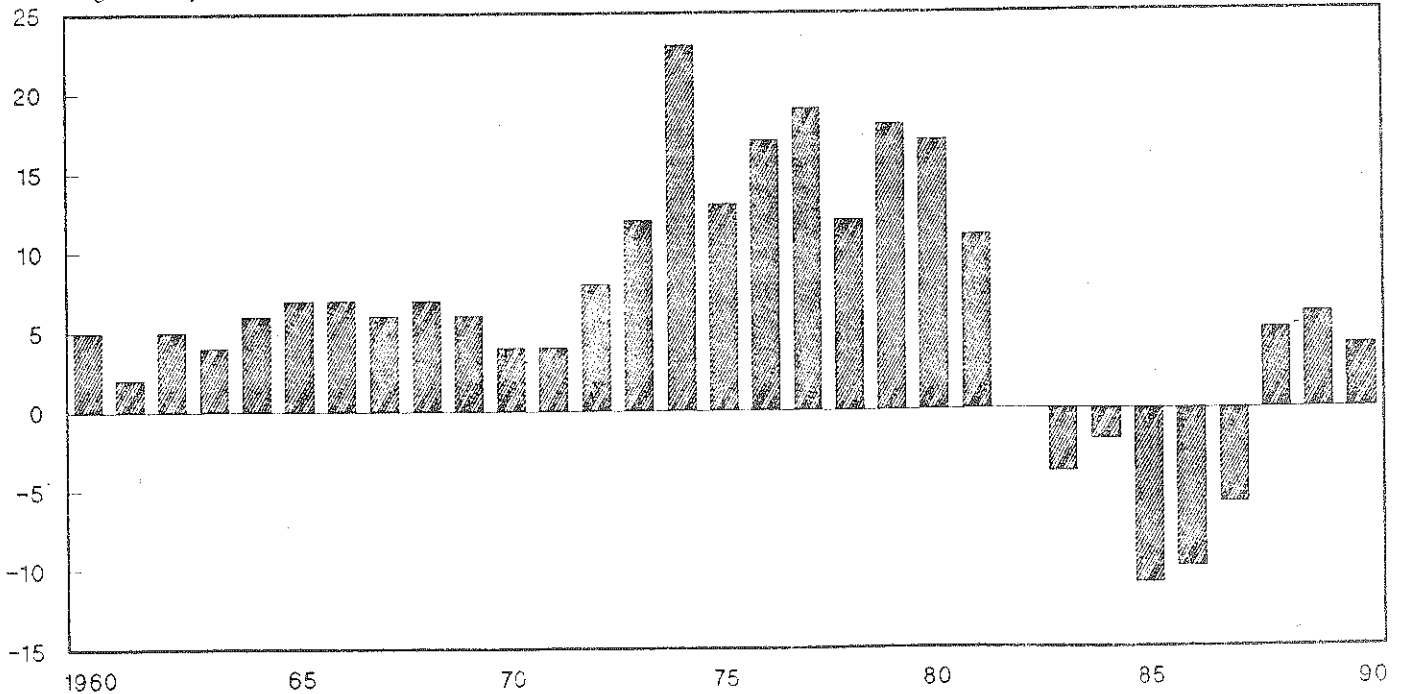

Source: Agricultural Land Values and Markets, ERS, USDA.

REAL ESTATE

AVERAGE VALUE PER ACRE OF UNITED STATES FARM REAL ESTATE

Table 1.--Average per acre value of farmland and buildings, by State, 1983-90 1/

State	As of April 1			As of February 1			As of	Percent change 1989-90	
	1983	1984	1985	1986	1987	1988	January 1 1990		
	Dollars							Percent	
Northeast:	1,343	1,391	1,346	1,340	1,491	1,586	1,794	1,802	0
Maine	703	713	774	854	885	962	1,039	1,029	0
New Hampshire	1,174	1,253	1,439	1,682	1,847	2,112	2,260	2,260	0
Vermont	842	862	947	1,060	1,114	1,124	1,203	1,203	0
Massachusetts	1,965	2,083	2,377	2,761	3,012	3,553	3,802	3,802	0
Rhode Island	2,760	2,770	2,990	3,284	3,389	4,748	5,080	5,080	0
Connecticut	2,655	2,723	3,005	3,372	3,557	4,171	4,463	4,463	0
New York	817	848	820	843	960	993	1,053	1,042	-1
New Jersey	3,140	2,959	2,951	2,997	3,729	3,969	4,644	4,737	2
Pennsylvania	1,520	1,596	1,427	1,332	1,540	1,579	1,911	1,911	0
Delaware	1,829	1,840	1,596	1,684	1,677	1,765	2,065	2,334	15
Maryland	2,121	2,236	2,197	2,023	2,639	2,261	2,487	2,512	1
Lake States:	1,160	1,147	952	797	707	788	831	835	6
Michigan	1,223	1,255	1,108	1,012	924	971	1,000	1,060	6
Wisconsin	1,113	1,104	944	836	777	826	867	867	0
Minnesota	1,155	1,131	898	694	587	700	749	831	11
Corn Belt:	1,482	1,449	1,108	972	900	1,003	1,107	1,129	2
Ohio	1,504	1,500	1,215	1,136	1,097	1,199	1,271	1,258	-1
Indiana	1,610	1,647	1,344	1,167	1,061	1,158	1,251	1,288	3
Illinois	1,837	1,845	1,381	1,232	1,149	1,262	1,380	1,416	2
Iowa	1,684	1,518	1,091	873	786	947	1,108	1,130	2
Missouri	856	875	689	648	604	640	678	706	4
Northern Plains:	520	518	412	360	331	368	401	435	8
North Dakota	439	447	373	334	303	319	329	348	6
South Dakota	348	363	289	267	238	269	293	337	15
Nebraska	701	645	485	414	400	457	526	562	7
Kansas	601	597	488	415	373	413	438	473	8
Appalachia:	1,082	1,107	1,035	1,025	1,004	1,037	1,095	1,171	7
Virginia	1,125	1,125	1,112	1,179	1,154	1,198	1,354	1,597	18
West Virginia	688	698	607	616	633	682	716	652	-9
North Carolina	1,314	1,429	1,331	1,254	1,259	1,263	1,339	1,325	-1
Kentucky	1,049	1,034	955	941	878	896	923	1,034	12
Tennessee	1,014	1,024	944	935	936	1,001	1,021	1,052	3
Southeast:	1,092	1,105	1,068	1,038	1,055	1,130	1,202	1,296	8
South Carolina	946	926	898	870	792	871	949	949	0
Georgia	929	921	886	853	889	920	1,003	1,053	5
Florida	1,576	1,645	1,599	1,537	1,605	1,790	1,897	2,125	12
Alabama	826	824	797	803	786	800	832	882	6
Delta States:	1,038	1,074	1,012	880	757	781	803	808	1
Mississippi	894	950	855	778	685	697	718	754	5
Arkansas	972	964	907	779	724	761	784	776	-1
Louisiana	1,351	1,430	1,407	1,191	921	940	959	940	-2
Southern Plains:	574	632	675	579	532	531	518	508	-2
Oklahoma	699	718	597	520	475	480	523	513	-2
Texas	544	612	694	594	546	544	517	506	-2
Mountain:	314	327	300	267	257	257	261	274	5
Montana	259	276	243	233	200	205	209	243	16
Idaho	814	808	739	631	552	572	601	685	14
Wyoming	193	199	181	159	157	147	143	153	7
Colorado	454	469	437	360	368	369	369	369	0
New Mexico	178	194	185	161	156	180	193	200	4
Arizona	289	311	295	271	299	279	276	268	-3
Utah	560	570	513	476	451	425	425	404	-5
Nevada	249	262	244	219	240	227	234	201	-14
Pacific:	1,356	1,399	1,293	1,201	1,084	1,089	1,140	1,208	6
Washington	933	972	943	840	756	739	769	815	6
Oregon	705	719	615	570	541	542	542	602	11
California	1,918	1,981	1,841	1,730	1,554	1,575	1,670	1,753	5
48 States	788	801	713	640	599	632	667	693	4

1/ Current dollars. Revised 1984-89 values based on values from the 1987 Census of Agriculture. Details in special report, "Revisions in the Farmland Value Series."

TAXES LEVIED ON FARM REAL ESTATE, BY STATE

Table 18.--Taxes levied on farm real estate, by States, 1987-1988 1/

State	Total taxes		Average tax per acre		Taxes per \$100 of full market value	
	1987	1988	1987	1988	1987	1988
	Million Dollars		Dollars		Dollars	
Northeast:						
Maine	10.4	11.4	7.80	8.53	.88	.89
New Hampshire	6.7	8.0	16.39	19.06	.89	.90
Vermont	16.8	17.2	12.01	12.38	1.08	1.10
Massachusetts	13.1	16.2	22.16	27.95	.74	.79
Rhode Island	2.4	2.6	42.41	44.95	1.25	.95
Connecticut	9.3	10.1	23.88	25.66	.67	.62
New York	134.2	141.7	16.04	17.14	1.67	1.73
New Jersey	28.4	30.5	32.37	35.53	.87	.90
Pennsylvania	104.9	112.0	13.48	14.57	.88	.92
Delaware	.8	.8	1.39	1.37	.08	.08
Maryland	21.2	21.3	8.93	9.37	.44	.41
Lake States:						
Michigan	311.3	314.9	30.31	30.94	3.28	3.19
Wisconsin	238.3	258.0	14.40	15.59	1.85	1.89
Minnesota	159.9	155.2	6.04	5.86	1.03	.84
Corn Belt:						
Ohio	144.9	148.5	9.71	9.95	.89	.83
Indiana	111.8	117.0	6.94	7.17	.65	.62
Illinois	494.3	474.7	17.38	16.69	1.51	1.32
Iowa	333.2	323.2	10.56	10.24	1.34	1.08
Missouri	67.5	68.6	2.32	2.37	.38	.37
Northern Plains:						
North Dakota	77.4	77.6	2.06	2.07	.68	.65
South Dakota	102.7	105.6	2.77	2.85	1.16	1.06
Nebraska	261.2	274.4	5.96	6.27	1.49	1.37
Kansas	121.6	131.7	2.62	2.84	.70	.69
Appalachia:						
Virginia	44.5	50.2	5.16	5.83	.45	.49
West Virginia	3.3	3.4	.99	1.01	.16	.15
North Carolina	50.0	51.7	5.33	5.62	.42	.44
Kentucky	33.6	32.7	2.41	2.36	.27	.26
Tennessee	46.1	47.1	3.97	4.06	.42	.41
Southeast:						
South Carolina	13.1	14.4	2.79	3.06	.35	.35
Georgia	48.7	52.3	4.57	4.93	.51	.54
Florida	101.4	107.2	9.34	10.04	.53	.56
Alabama	10.5	11.0	1.16	1.23	.15	.15
Delta States:						
Mississippi	19.4	19.8	1.85	1.93	.27	.28
Arkansas	39.5	40.0	2.79	2.83	.39	.37
Louisiana	19.0	19.2	2.39	2.47	.26	.26
Southern Plains:						
Oklahoma	55.3	54.7	1.83	1.81	.39	.38
Texas	307.9	304.6	2.41	2.39	.44	.44
Mountain:						
Montana	84.1	85.3	1.19	1.21	.59	.59
Idaho	41.1	39.2	3.63	3.48	.66	.61
Wyoming	16.7	16.8	.71	.71	.54	.48
Colorado	59.3	61.6	1.99	2.09	.45	.57
New Mexico	10.9	10.9	.36	.36	.23	.20
Arizona	40.7	40.7	4.70	4.77	1.57	1.71
Utah	11.9	12.1	1.69	1.72	.37	.41
Nevada	3.0	3.5	.57	.66	.24	.29
Pacific:						
Washington	60.2	60.2	4.69	4.69	.62	.63
Oregon	72.7	76.2	4.49	4.73	.83	.87
California	247.0	245.8	9.46	9.50	.61	.60
Hawaii	21.2	21.8	12.48	12.74	.72	.66
49 States 2/	4,233.5	4,304.2	4.82	4.92	.80	.77

1/ 1987 numbers revised.
2/ Excludes Alaska.

REAL ESTATE

CREDIT-FINANCED FARMLAND TRANSFERS BY TYPE OF LENDER

Table 16.--Credit-financed farmland transfers: Percent of credit volume extended, by type of lender, 1981-90 1/

Regions and type of lender	1981	1982	1983	1984	1985	1986	1987	1988	1989	1990
Percent										
Northeast:										
Sellers	38	38	29	29	32	28	31	27	22	19
Commercial banks	6	6	9	16	17	24	27	36	32	30
Insurance companies	*	*	1	1	*	*	2	*	1	*
Farm Credit System	34	35	39	27	23	20	19	24	40	41
Others	22	21	22	27	27	28	20	12	5	10
Lake States:										
Sellers	59	60	44	44	49	53	41	39	38	33
Commercial banks	2	4	6	10	12	16	30	31	37	39
Insurance companies	1	1	1	3	1	1	*	*	*	2
Farm Credit System	28	25	38	32	24	17	18	20	20	16
Others	10	10	11	11	15	13	10	10	5	10
Corn Belt:										
Sellers	38	37	37	32	27	30	20	17	20	21
Commercial banks	4	4	10	15	16	38	45	54	44	37
Insurance companies	4	5	5	4	8	3	7	2	7	10
Farm Credit System	44	44	37	36	33	16	15	15	25	25
Others	10	10	10	13	16	12	13	12	4	7
Northern Plains										
Sellers	44	35	32	27	25	49	24	19	24	31
Commercial banks	3	4	4	7	14	20	36	33	30	26
Insurance companies	3	3	2	4	4	10	2	3	4	2
Farm Credit System	34	39	42	43	39	14	23	34	33	26
Others	16	19	21	20	19	7	14	11	9	15
Appalachia:										
Sellers	21	27	17	17	26	27	15	18	30	18
Commercial banks	9	12	20	27	25	35	54	47	40	45
Insurance companies	2	2	4	1	1	*	1	1	*	*
Farm Credit System	42	38	33	33	25	18	13	21	24	27
Others	26	21	26	24	23	20	16	14	6	10
Southeast:										
Sellers	25	14	17	24	22	24	35	25	8	26
Commercial banks	5	5	19	9	10	16	23	44	48	37
Insurance companies	1	3	1	7	1	2	12	7	18	15
Farm Credit System	46	63	50	41	43	34	17	16	22	18
Others	25	15	12	20	23	23	12	9	4	4
Delta States:										
Sellers	20	15	13	19	15	9	19	7	13	16
Commercial banks	6	5	15	14	18	27	22	25	31	33
Insurance companies	3	15	3	3	9	10	3	7	20	6
Farm Credit System	47	44	42	38	29	34	12	40	31	32
Others	24	21	26	27	30	19	44	21	5	13
Southern Plains:										
Sellers	43	43	31	23	24	30	15	14	27	35
Commercial banks	7	5	9	13	11	13	23	26	29	16
Insurance companies	6	1	9	3	3	18	9	*	2	1
Farm Credit System	29	34	27	37	35	25	24	39	35	40
Others	15	17	25	23	28	14	29	21	7	8
Mountain:										
Sellers	46	56	41	22	50	42	52	33	40	37
Commercial banks	1	1	2	3	3	3	8	6	17	9
Insurance companies	9	5	7	18	1	1	2	7	7	9
Farm Credit System	35	27	35	37	29	27	26	35	27	32
Others	9	10	15	20	17	26	11	19	9	13
Pacific:										
Sellers	49	56	52	30	39	31	30	39	40	45
Commercial banks	4	1	2	6	7	9	12	3	10	5
Insurance companies	10	6	1	17	5	1	21	19	2	15
Farm Credit System	31	26	31	38	32	49	24	22	35	28
Others	6	11	13	9	17	10	12	18	13	7
48 States:										
Sellers	40	41	33	28	33	32	30	24	24	28
Commercial banks	4	4	9	11	13	21	28	32	34	28
Insurance companies	4	4	4	7	3	5	7	5	7	8
Farm Credit System	37	37	37	36	31	25	19	25	29	27
Others	15	14	16	18	20	17	16	14	6	9

* = Less than 0.5 percent

1/ Based on reported sales during the 5 months ending March 1, 1981-85, the 5 months ending February 1, 1986-89, and the 4 months ending January 1, 1990. Beginning in 1989, the Farm Credit System includes the Federal Land Banks and Production Credit Associations (PCA'S). In preceding years, the PCA'S were included in the "Others" group.

CROP PRODUCTION
United States and New York
1988-90 ^{a/}

Crop	Acres Harvested			Yield Per Acre			Production		
	1988	1989	1990	1988	1989	1990	1988	1989	1990
<u>United States</u>	(million)			(bu.)			(million bu.)		
Corn grain	58.3	64.8	66.7	84.6	116.2	119.0	4,929	7,527	7,935
Sorghum	9.0	11.2	9.3	63.8	55.4	60.5	577	618	560
Oats	5.5	6.9	6.0	39.3	54.3	60.2	217	374	358
Barley	7.6	8.3	7.6	38.0	48.6	55.2	290	404	419
Wheat	53.2	62.2	69.4	34.1	32.7	39.6	1,812	2,037	2,744
Soybeans	57.4	59.5	56.5	27.0	32.3	33.7	1,549	1,924	1,904
<u>New York</u>	(thousand)			(bu.)			(thousand bu.)		
Corn grain	540	570	610	85	93	101	45,900	53,010	61,610
Oats	145	155	135	52	59	61	7,540	9,145	8,235
Wheat	90	130	145	55	45	49	4,950	5,850	7,105
				(tons)			(thousand tons)		
Corn silage	525	550	NA	13	13	NA	6,825	7,150	NA
All hay	2,070	2,080	2,110	2.27	2.18	2.50	4,697	4,538	5,265
Alfalfa ^{b/}	880	840	890	2.70	2.45	2.90	2,376	2,058	2,581

Source: USDA Crop Production and New York Crop Reporting Service.

^{a/} All 1990 data are preliminary and subject to revision. Estimates for the United States are as of November 1, 1990. New York estimates are as of October 1990, except for corn which is November 1990.

^{b/} Includes alfalfa mixtures.

Grain production in the United States in 1990 is projected to be slightly above year-earlier levels. Corn for grain production of 7.9 billion bushels is 5 percent above the 1989 crop and the largest crop since 1986. Sorghum production is 9 percent below the 1989 level.

The production of oats is down 4 percent from the 1989 level. Barley production is up 4 percent from last year. Total feed grain production is up 4 percent from the 1989 level.

The soybean crop is about 1 percent below the 1989 crop. Wheat production of 2.7 billion bushels is up 35 percent from the 1989 crop.

The New York corn for grain crop is forecast at 62 million bushels, up 16 percent from 1989. New York corn yield is expected to be 101 bushels per acre, up from 93 in 1989. Wheat production is up 21 percent from 1989. The production of oats is estimated to be down 10 percent from 1989. Hay production is up 16 percent from the 1989 level.

GRAIN AND FEED

CORN AND FEED GRAIN BALANCE SHEETS

Item	1987/88	1988/89	1989/90 (Prelim.)	1990/91 (Proj.)
<u>Supply</u> ----- CORN (million bushels) -----				
Beginning Stocks (Sept. 1)	4,882	4,259	1,930	1,344
Production	7,072	4,929	7,527	7,935
Imports	4	3	2	2
Total	11,958	9,191	9,460	9,281
<u>Disappearance</u>				
Feed and Residual	4,738	3,987	4,458	4,700
Food, Ind. and Seed	1,229	1,245	1,290	1,320
Total Domestic	5,967	5,232	5,748	6,020
Exports	1,732	2,028	2,367	2,025
Total	7,699	7,260	8,115	8,045
<u>Ending Stocks</u> (Aug. 30)	4,259	1,930	1,344	1,236
Season average farm price	\$1.94	\$2.54	\$2.36	\$2.20-2.60

<u>Supply</u> -- FEED GRAINS ^{a/} (million metric tons) --				
Beginning Stocks	152.1	133.6	65.9	45.5
Production	215.4	149.3	221.1	230.1
Imports	1.1	1.2	1.4	1.2
Total	368.6	284.2	288.4	276.9
<u>Disappearance</u>				
Feed and Residual	145.5	119.6	134.3	139.2
Food, Ind. and Seed	36.8	37.5	38.7	39.7
Total Domestic	182.3	157.1	173.0	178.8
Exports	52.6	61.1	69.9	59.0
Total	234.9	218.3	242.9	237.9
<u>Ending Stocks</u>	133.6	65.9	45.5	39.0

Source: Agricultural Supply and Demand Estimates, USDA, November 8, 1990.

^{a/} Marketing year beginning September 1 for corn and sorghum, June 1 for barley and oats.

The fall 1990 corn supply of 9.3 billion bushels is down 2 percent from 1989 and much smaller than the levels of 1985-87. Feed use is projected to increase 5 percent and be about equal to the 1985-88 levels. Exports are projected to decrease 14 percent from 1989 levels. Total utilization is expected to be slightly below the 1989/90 level. Projected carryover in the fall of 1991 of 1.2 billion bushels is slightly below the fall 1990 carryover and the smallest since 1985.

Feedgrain supplies are dominated by corn, so changes in supply and demand are similar. The total supply of feedgrains is 4 percent below last year. Domestic feed use in the 1990-91 marketing year is projected to increase 4 percent. Exports are projected to decrease 16 percent. Carryover stocks at the end of the 1990-91 marketing year are projected to be 39 million metric tons, the lowest since 1985.

WHEAT AND SOYBEAN BALANCE SHEETS

Item	1987/88	1988/89	1989/90 (Prelim.)	1990/91 (Proj.)
<u>Supply</u> ----- WHEAT (million bushels) -----				
Beginning Stocks (June 1)	1,821	1,261	702	536
Production	2,107	1,812	2,037	2,744
Imports	17	23	23	23
Total	3,945	3,096	2,762	3,303
<u>Disappearance</u>				
Food	726	715	731	745
Seed	85	103	101	88
Food and Residual	281	157	160	450
Total domestic	1,092	975	992	1,283
Exports	1,592	1,419	1,233	1,075
Total	2,684	2,394	2,225	2,358
<u>Ending Stocks</u> (May 31)	1,261	702	536	945
Season average farm price	\$2.57	\$3.72	\$3.72	\$2.55-2.75

<u>Supply</u> ----- SOYBEANS (million bushels) -----				
Beginning Stocks (Sept. 1)	436	302	182	239
Production	1,923	1,549	1,924	1,904
Imports	NA	4	3	2
Total	2,359	1,855	2,109	2,145
<u>Disappearance</u>				
Crushings	1,174	1,058	1,146	1,185
Exports	802	527	623	610
Seed, Feed	56	59	57	59
Residual	25	29	44	36
Total	2,057	1,673	1,870	1,890
<u>Ending Stocks</u> (Aug. 30)	302	182	239	255
Season average farm price	\$5.88	\$7.42	\$5.70	\$5.35-6.35

Source: Agricultural Supply and Demand Estimates, USDA, November 8, 1990.

The 1990 United States wheat supply of 3.3 billion bushels is 19 percent above the 1989 level. Domestic food use is projected to increase slightly. Feed use is projected to nearly triple. Exports are projected to decrease 13 percent. Carryover on May 31, 1991 is projected to be 945 million bushels, up 76 percent from the 1990 level. If realized, this will be the largest wheat carryover since 1988.

The total soybean supply is 2.1 billion bushels, up 2 percent from 1989 but below the levels of the mid-1980s. Crushings are projected to be up 3 percent and exports to decrease 2 percent from year-earlier levels. Carryover in the fall of 1991 is projected to be about 255 million bushels, 7 percent above the 1990 carryover.

GRAIN AND FEED

PRICES RECEIVED FOR CORN, WHEAT AND SOYBEANS

DOLLARS PER BU

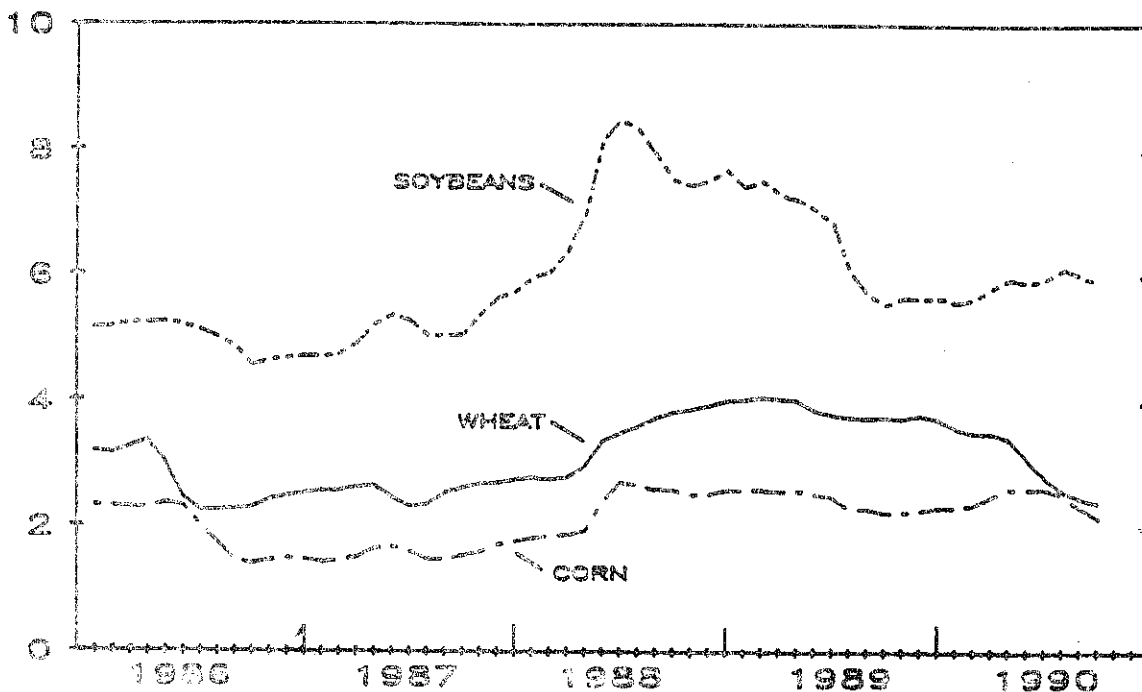

Source: USDA Agricultural Prices.

Soybean prices, after reaching a peak in mid-1988, generally declined until the fall of 1989. Prices increased from then until mid-1990. The October 1990 average price received by U.S. farmers was \$5.90, \$0.36 per bushel above the level of October 1989.

USDA's projection for the season average price of 1990 crop soybeans is \$5.35 to \$6.35, with a mid point \$0.15 above the average price for the 1989 crop.

Wheat prices declined quite steadily from the fall of 1989 to the fall of 1990. The October 1990 price received by U.S. farmers was \$2.39, \$1.36 below the year-earlier price. The New York price of \$2.37 was \$1.58 below the October 1989 level.

The projected season average price for the 1990 U.S. wheat crop is \$2.55 to \$2.75. The mid point is \$1.07 below the average price received by farmers for the 1989 crop.

Corn prices increased from mid-1989 to mid-1990 but then declined somewhat. The U.S. average price received by farmers in October 1990 was \$2.15, \$0.07 below the year-earlier level. The New York price in mid October was \$2.89 per bushel, \$0.36 above the average level for the entire month of October 1989.

The mid November USDA projection of the season average price received by U.S. farmers for the 1990 corn crop was \$2.20 to \$2.60 per bushel. The mid point is \$0.04 above the season average price for the 1989 crop.

MONTHLY PRICES OF SOYBEAN MEAL AND MIDLINGS 1982 TO DATE

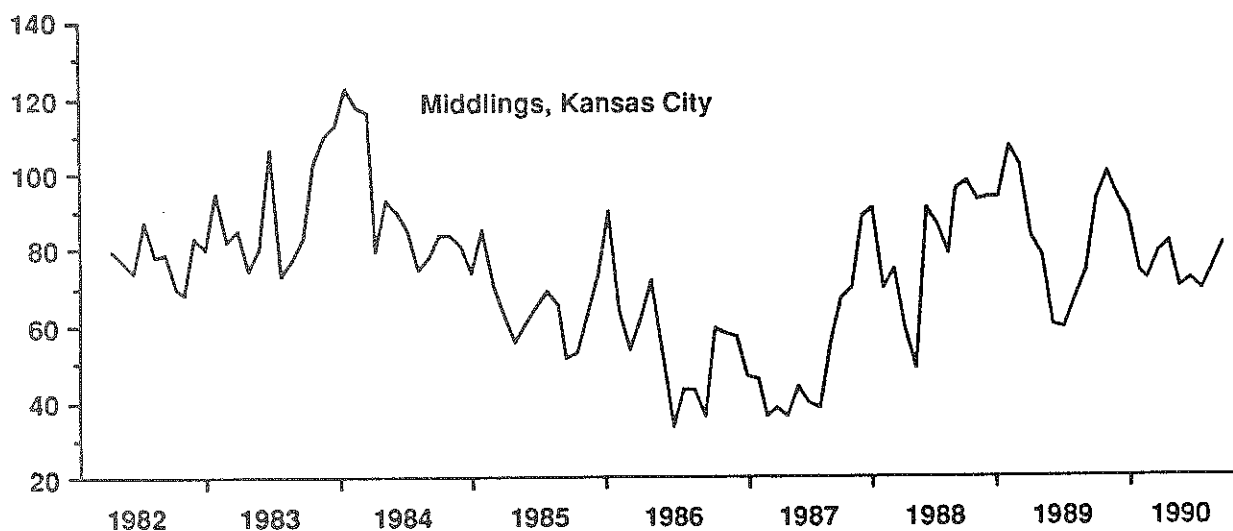
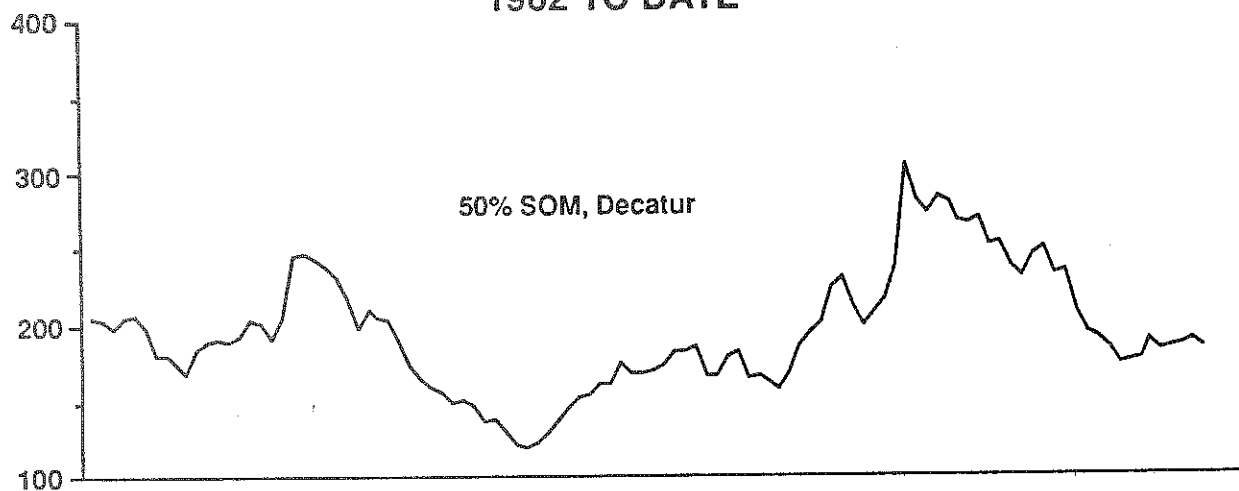

Source: USDA Feed Situation and Feedstuffs.

Prices of soybean oil meal (50%, Decatur) generally declined from a high of over \$300 in June 1988 to around the \$175 level in early 1990. October 1990 prices were about \$24 below year-earlier levels. Prices are likely to rise seasonally and be slightly above year-earlier levels during the winter and spring of 1991.

Prices of byproducts such as mirlings continue to fluctuate widely and are not closely related to the prices of the grains from which they are derived. Prices of these byproducts in the fall of 1990 were below year-earlier levels.

GRAIN AND FEED

**PRICES OF 18% DAIRY, 44% SOM, AND LAYER FEED,
1989 & 1990, NORTHEAST**

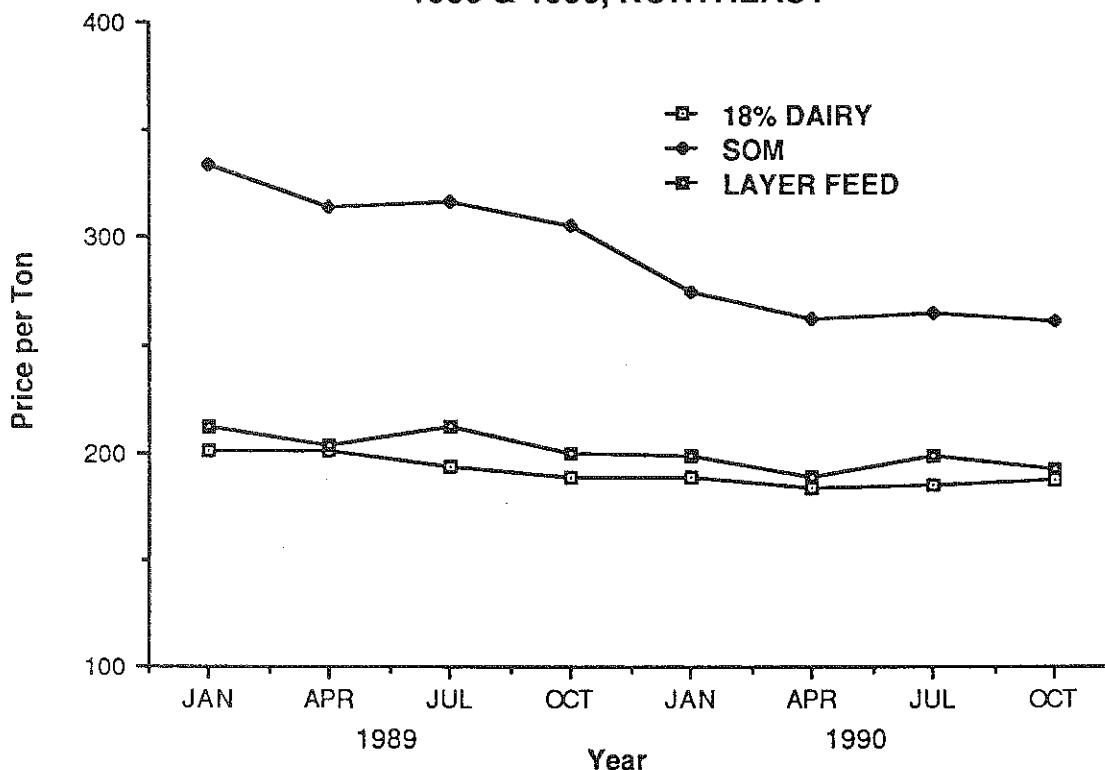

Source: USDA Agricultural Prices and New York Crop Reporting Service.

Feed prices have been relatively stable during 1990 with some decline from the fall of 1989 to the fall of 1990. In October 1990, prices for 18% dairy feed were about \$2 per ton below the prices of a year earlier. Layer feed prices were \$7 per ton below the levels of a year earlier. In October 1990, prices of 44% soybean meal were about \$45 per ton below levels of a year earlier.

Month	1990			1991		
	18% Dairy	44% SOM	Layer feed	18% Dairy	44% SOM	Layer feed
Jan.	189	274	198	_____	_____	_____
Apr.	184	262	188	_____	_____	_____
July	185	264	198	_____	_____	_____
Oct.	187	260	192	_____	_____	_____

Only quarterly data are available after February 1986, and those data are for New York and New England combined.

Layer feed and 18% dairy prices in the first half of 1991 are likely to be close to the levels of the first half of 1990. Soybean meal prices in the first half of 1991 are likely to be slightly above year-earlier levels.

HIGHLIGHTS OF THE 1990 FRUIT OUTLOOK

The total production of the six tree and vine crops which are important to New York's agricultural economy was projected to decrease by six percent nationally. The national production of apples, grapes, tart cherries, peaches, and sweet cherries were forecast to decline compared with last year's production, while increased production was forecast for pears. The production of apples was forecast at 226 million bushels, down five percent from 1989. Grape production was expected to total 5,460 thousand tons, a decrease of eight percent from last year.

In New York, apple production is indicated to be 23.6 million bushels, three percent above the 1989 output, while grape production of 145,000 tons is expected, five percent below last year. Total production of the six major fruit and vine crops of 674 thousand tons is projected for the State, marginally increased from the previous year.

The utilized value of the major fruit crop for the last 10 years is shown below. The value of production has been as high as \$206* million in 1988.

*The value of the fresh apple crop is based on the "as sold" price for apples rather than "packinghouse door equivalent".

VALUE OF PRODUCTION OF MAJOR FRUIT CROPS,
NEW YORK STATE, 1980-1989

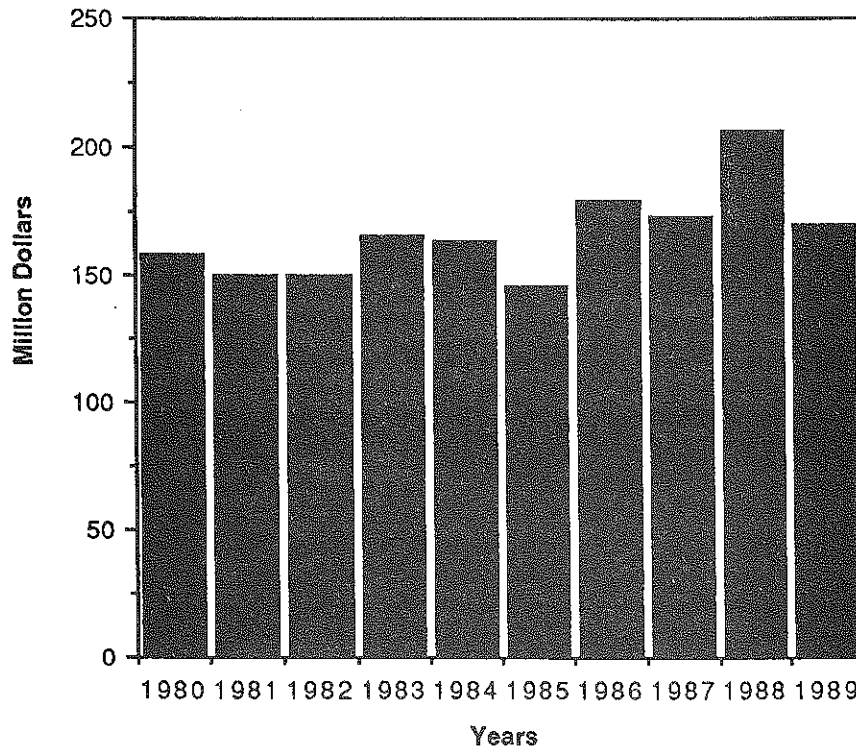

COMMERCIAL NON-CITRUS FRUIT PRODUCTION, NEW YORK AND UNITED STATES

Fruit	New York				United States			
	1987	1988	1989*	1990	1987	1988	1989*	1990
----- thousand tons -----								
Apples	444	455	480	495	5,371	4,566	5,003	4,746
Grapes	178	157	152	145	5,267	6,034	5,895	5,460
Tart Cherries	18	11	16	10	179	118	137	112
Pears	15	17	17	16	938	861	909	939
Peaches	7	7	6	7	1,191	1,307	1,167	1,061
Sweet Cherries	2	1	1	1	215	186	194	152
Total New York's Major Fruit Crops	664	648	672	674	13,161	13,072	13,305	12,470

*indicated

AVERAGE FARM PRICES OF NON-CITRUS FRUITS, NEW YORK AND UNITED STATES

Fruit	New York				United States			
	1986	1987	1988	1989	1986	1987	1988	1989
----- dollars per ton -----								
Apples								
Fresh	330	274	306	296	382	254	348	268
Processed	118	114	143	133	116	79	123	108
All sales	202	184	216	168	268	172	254	210
Grapes	201	228	230	254	226	259	266	290
Tart Cherries	460	190	450	302	406	156	374	264
Pears	210	259	235	223	267	198	274	290
Peaches	472	430	544	588	282	276	312	326
Sweet Cherries	849	727	820	783	825	748	788	712

VALUE OF UTILIZED PRODUCTION NON-CITRUS FRUITS, NEW YORK AND UNITED STATES

Fruit	New York				United States			
	1986	1987	1988	1989	1986	1987	1988	1989
----- million dollars -----								
Apples								
Fresh	59.4	52.1	62.0	65.1	863	711	914	788
Processed	31.9	28.5	36.4	34.8	196	192	237	219
All Sales*	91.3	80.6	98.4	100.0	1,059	903	1,150	1,007
Grapes	32.9	40.5	36.1	38.6	1,180	1,359	1,603	1,712
Tart Cherries	2.8	2.3	4.8	3.4	44	22	44	32
Pears	3.8	3.8	4.1	3.6	203	185	235	264
Peaches	3.3	3.0	3.7	3.6	315	308	382	360
Sweet Cherries	1.2	0.9	1.0	0.9	113	159	145	137
Total New York's Major Fruit Crops	135.3	131.1	148.1	150.1	2,914	2,936	3,560	3,512

*May not add from total of fresh and processed due to rounding errors.

APPLE PRODUCTION, UNITED STATES, 1985-1989, FIVE-YEAR AVERAGE PRODUCTION,
AND 1990 FORECAST, 1,000 42-POUND BUSHELS

States/Regions	5-Year Average 1985-89*	1989*	1990 USDA Estimate**	1990 Compared to 5-Year Average (Percent Change)
Maine	1,957	1,643	2,024	3.4
New Hampshire	1,167	976	1,119	-4.1
Vermont	1,105	1,071	1,071	-3.0
Massachusetts	2,000	1,857	2,024	1.2
Rhode Island	126	132	131	3.9
Connecticut	938	857	1,000	6.6
New York	22,572	22,857	23,571	4.4
New Jersey	1,895	1,143	1,310	-30.9
Pennsylvania	12,024	7,619	11,190	-6.9
Delaware	505	357	464	-8.1
Maryland	1,419	881	905	-36.2
Virginia	9,643	7,738	5,000	-48.1
West Virginia	4,619	2,738	3,452	-25.3
North Carolina	6,452	5,238	5,476	-15.1
South Carolina	781	833	714	-8.5
Georgia	752	595	595	-20.8
Total East	67,955	56,535	60,048	-11.6
Ohio	2,881	2,976	2,857	-0.8
Indiana	1,447	1,524	1,357	-6.2
Illinois	2,262	2,167	1,548	-31.6
Michigan	22,048	22,619	17,857	-19.0
Wisconsin	1,405	1,548	1,071	-23.7
Minnesota	538	738	524	-2.6
Iowa	238	274	274	15.0
Missouri	1,252	1,310	976	-22.0
Kansas	262	310	190	-27.3
Kentucky	329	381	190	-42.1
Tennessee	281	274	214	-23.7
Arkansas	233	214	262	12.4
Total Central	33,176	34,335	27,321	-17.6
Total East & Central	101,131	90,870	87,369	-13.6
Colorado	1,848	1,667	833	-54.9
New Mexico	209	126	274	31.0
Utah	1,214	1,333	619	-49.0
Idaho	3,205	3,762	3,929	22.6
Washington	91,000	119,047	111,905	23.0
Oregon	3,762	3,810	4,167	10.8
California	14,714	16,071	15,476	5.2
Arizona	N.A.	590	952	N.A.
Total West	115,952	146,406	138,155	19.1
TOTAL U.S.	217,083	237,276	225,524	3.9

*1989 and 5-year average are USDA data revised as of July 1990.

**NASS, USDA, Crop Production, October 1990.

**APPLE PRODUCTION IN NEW YORK STATE, BY REGION,
1981-1989, AND 1990 (Estimated)**

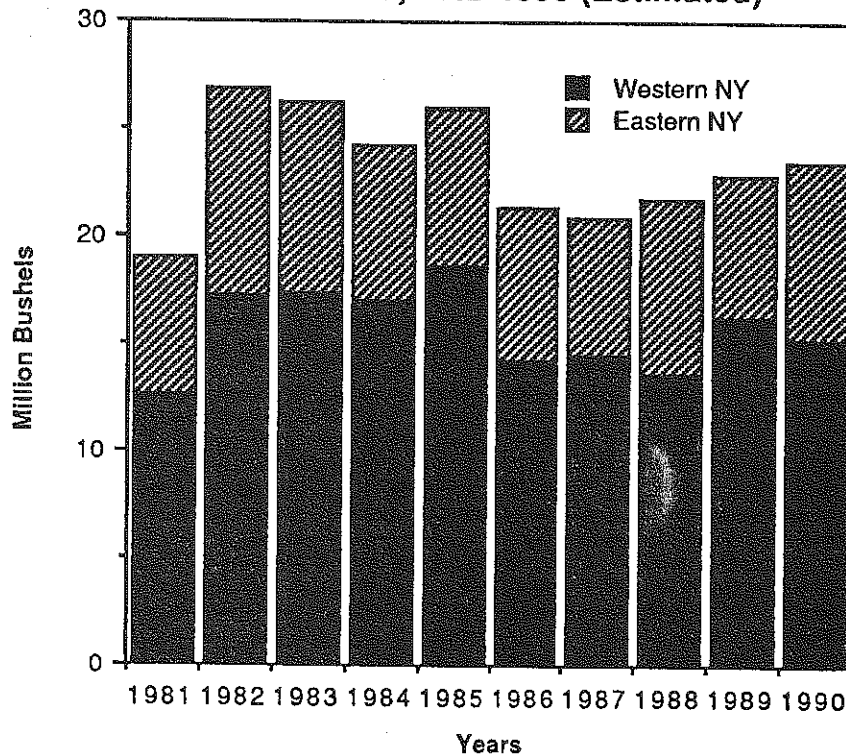

Of the projected 23.6 million bushel crop for 1990, an 8.3 million bushel crop is indicated for eastern New York and a 15.2 million bushel crop is indicated for western New York. Thus, the indicated production in eastern New York is 25 percent above 1989 while the crop in western New York is expected to be six percent below last year. The total crop is approximately four percent above the average of the past five years.

Lower production in 1986-1988 occurred due to (1) three consecutive years of poor weather conditions, especially in western New York, and (2) orchard removal. Even though production has not been high in recent years, the potential productive capacity has increased due to plantings of higher density, more productive systems which are currently nonbearing or in early bearing years, but will have an impact on production in future years. The extent of removals and new plantings will be documented by the Orchard and Vineyard Survey for 1990 now being conducted by the New York Agricultural Statistics Service.

Cold storage holding patterns, shown on the following page, indicate that eastern New York is the primary fresh fruit production area in New York. However, western New York is becoming more important as a fresh fruit producer, as indicated in the increased emphasis on controlled atmosphere storage. Cold storage holdings, including CA holdings, are well above the normal pattern. Compared with the most recent five-year average holdings, eastern New York is 14 percent above the five-year average, while western New York is three percent above the average of 1985-1989.

APPLES IN COLD STORAGE, EASTERN NEW YORK, AS OF OCTOBER 31, REGULAR STORAGE AND CA, 1981-1990

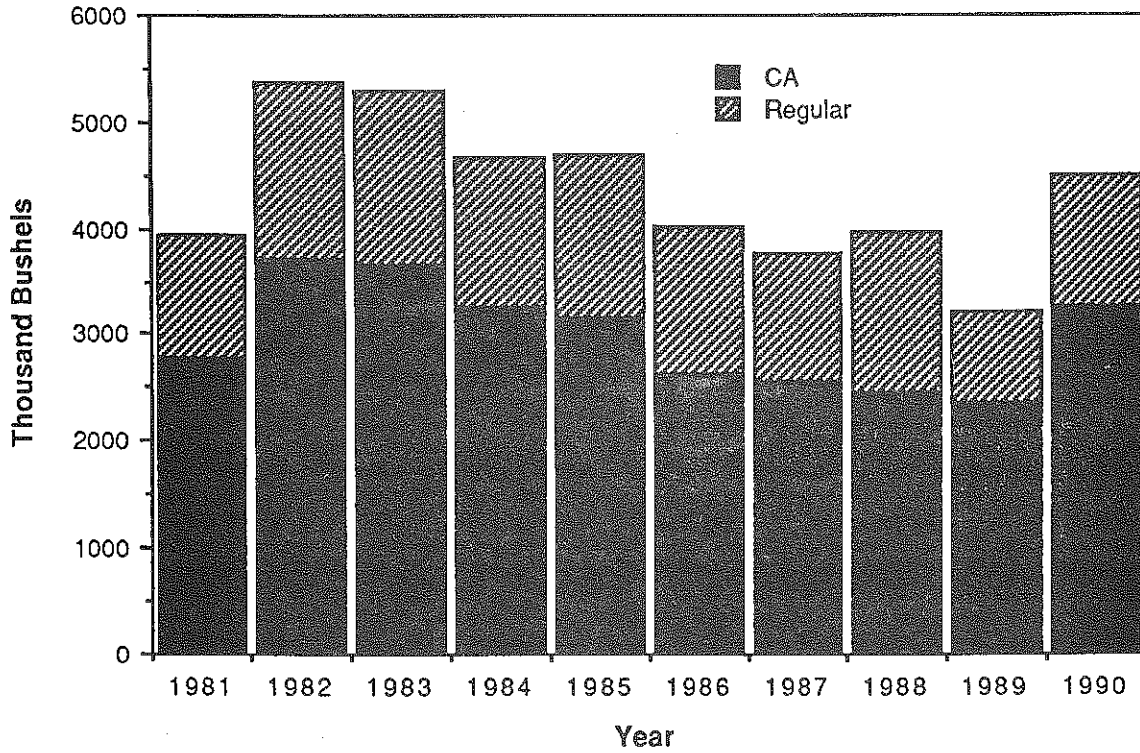

APPLES IN COLD STORAGE, WESTERN NEW YORK, AS OF OCTOBER 31, REGULAR STORAGE AND CA, 1981-1990

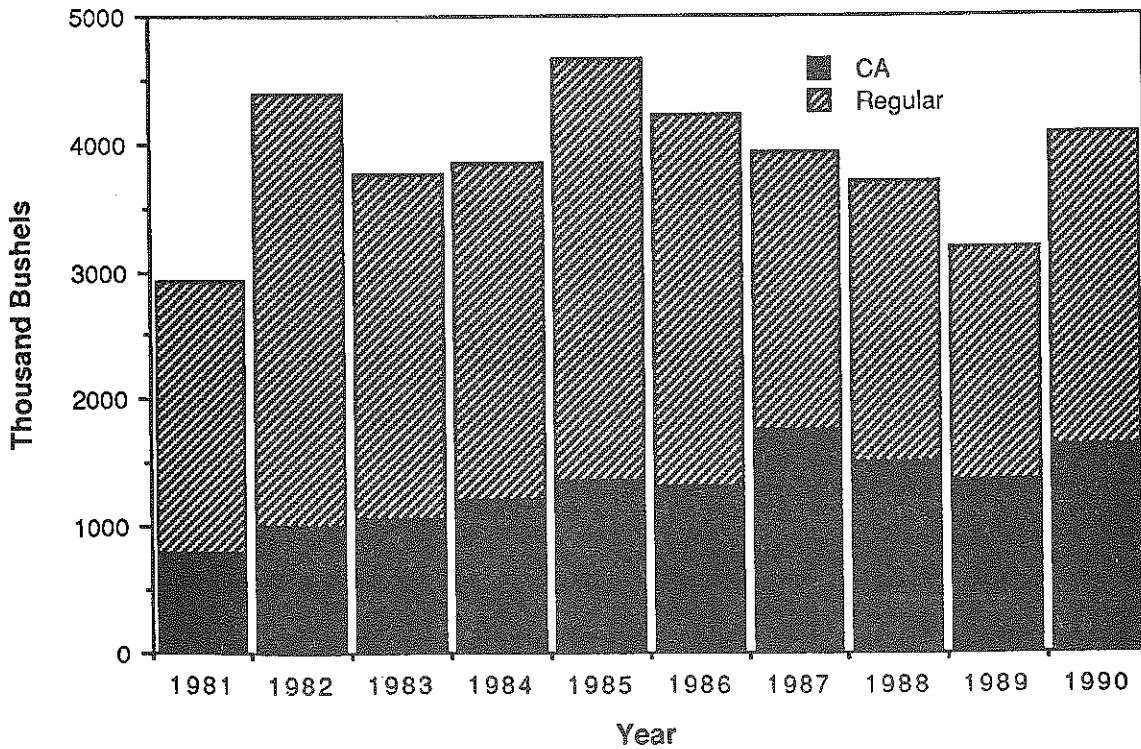

AVERAGE ANNUAL PRICES RECEIVED BY NEW YORK GROWERS FOR APPLES, 1980-1989

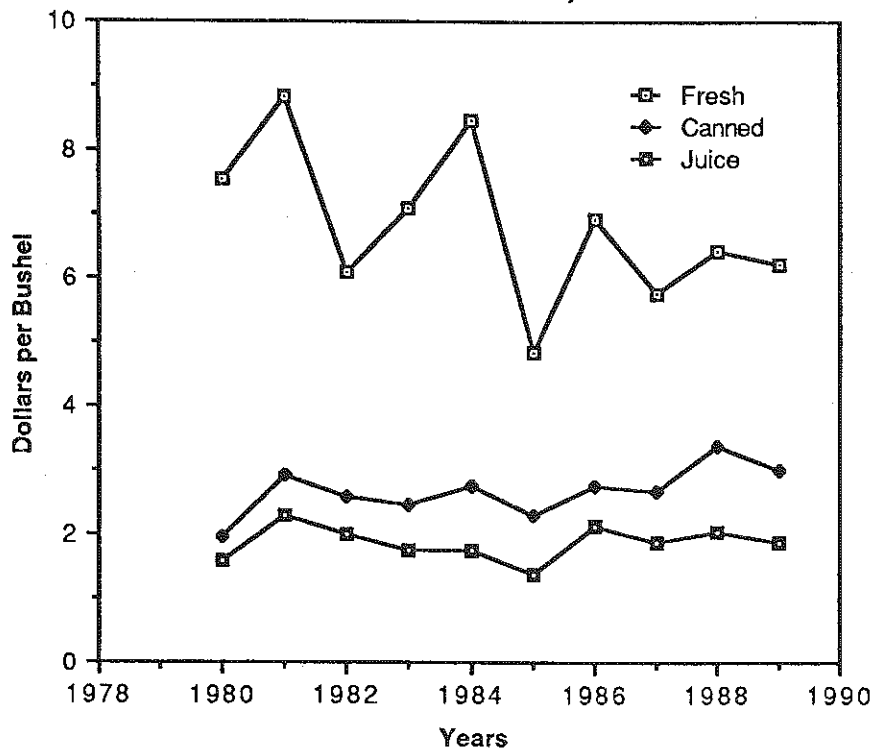

Over the past 10 years, prices for processed apples have been fairly constant, while fresh apple prices have more pronounced fluctuations due to particular supply and demand conditions in a given year. (Note: Beginning in 1985, the price of fresh apples was reported based on a packinghouse door equivalent rather than "as sold". Therefore, the 1985-89 prices are not directly comparable to the fresh prices prior to 1985.)

In October 1990, the average price of fresh apples sold in New York averaged seven percent above a year ago when there was a larger national crop. Prices of McIntosh apples in October were \$9-11 per box for bagged apples and \$15-16 for boxes of cell packed apples. Prices last year were about \$10 for bagged apples and \$15-16 for cell packs. Thus, prices for cell packed Macs were about the same as last year while the prices of bagged apples were stronger than a year ago. Price prospects for New York fresh apples are strong for the remainder of the marketing season, with low inventories in storage nationally and a short crop in eastern and central United States (see page 41). Red Delicious prices were steady this year due to a crop that was well below 1989 in Washington State, but still above the five-year average.

Processed apple prices were also higher this fall. Major processors were paying \$8-10 per hundredweight for 2-1/2" and up, compared with \$6.75-7.50 last year; and \$4.00-4.50 for juice apples, compared with \$3.75-4.00 in 1989. As the harvest season progressed, prices for processing apples advanced, and apples were stored in expectation of still higher prices later in the season.

Grapes

The value of utilized production for grapes in New York increased rapidly during the 1960's and early 1970's, reaching a peak of \$45.9 million in 1978. For several years after 1978, the value was generally declining and reached a low of \$25.9 million in 1985. In the past four seasons, the State's industry has recovered, fueled by a lower-valued dollar which increased the prices of competing imports of wine and juice; and new product development, promotion, and development of export markets in the grape juice sector. A steep 17 percent decline in the national wine cooler market and a continued slide in non-premium table wine consumption affected the 1989 value.

Final results for the 1990 season will be mixed, with the grape juice sector continuing strong, while the large winery sector continues to be plagued by sluggish or declining demand for wine coolers and lower-priced table wines. With a smaller crop in 1990, the utilized value of grapes in New York is likely to fall slightly from the 1989 value of \$38.6 million.

VALUE OF UTILIZED PRODUCTION OF GRAPES, 1980-1989

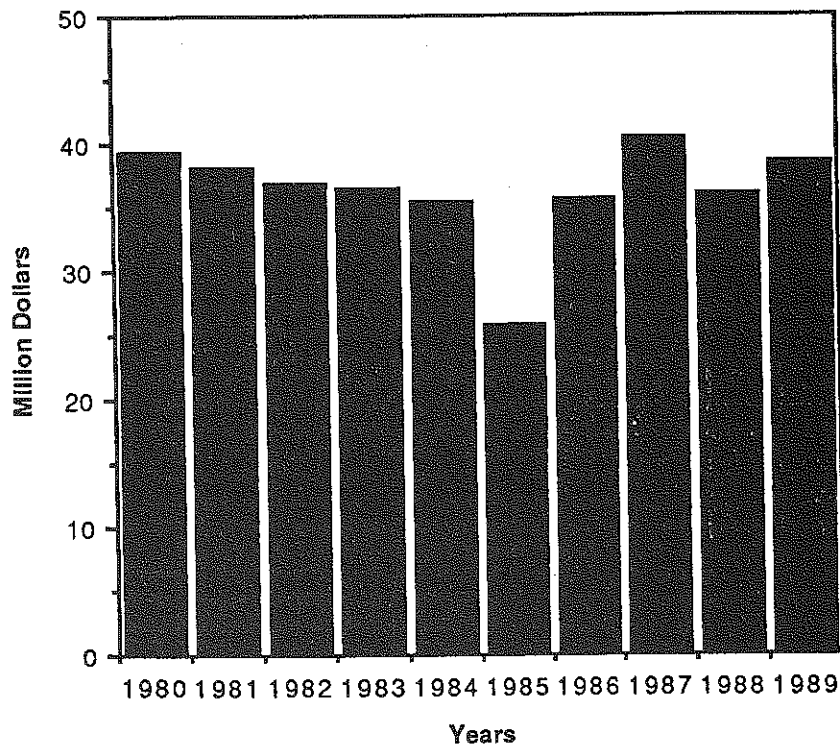

With strong demand for juice and nonfermented products and the use of Concords in wine coolers and other fermented products, Concords have continued to account for about 70 percent of New York's grape production.

TOTAL PRODUCTION OF GRAPES IN NEW YORK, CONCORD AND OTHER VARIETIES, 1980-1989 AND 1990 (Estimated)

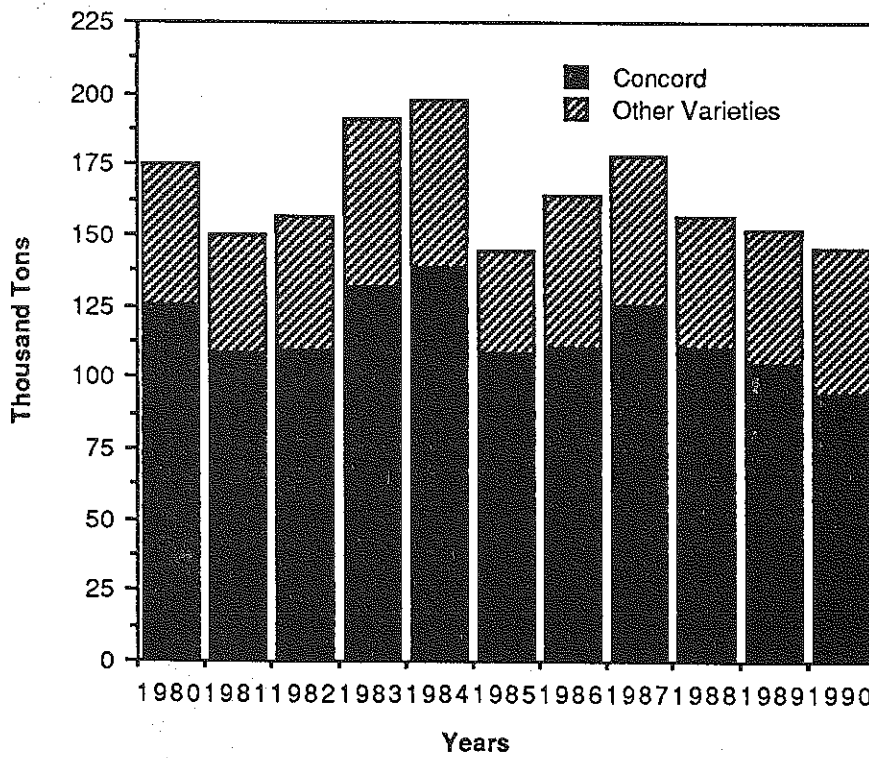

Wine

Changes have occurred in the market for wine which have serious implications for New York's growers. These are shown in the next three charts.

- 1) The total consumption of all wine declined during the last three years. Growth in recent years had been attributable to the wine cooler segment. The U.S. wine market decreased 5.2 percent in 1989.
- 2) Table wine consumption had decreased for three consecutive years in 1985-87. California has managed to hold its volume, while imports and wine produced in "other states" have shown declining shares. [Note: New York makes up about one-half of the volume of "other states".] After a modest one-half percent increase in 1988, table wine consumption again decreased about three percent in 1989.
- 3) In 1988, wine cooler consumption decreased after several years of spectacular growth. "Other states", again primarily New York, had been a strong beneficiary of the growth in the cooler market. In 1989, wine cooler consumption was down 17 percent.

Considered together, these three trends have spelled a decreased demand for New York grapes used for nonpremium wines.

**WINE ENTERING DISTRIBUTION CHANNELS IN THE U.S.,
BY TYPE, 1980-1989**

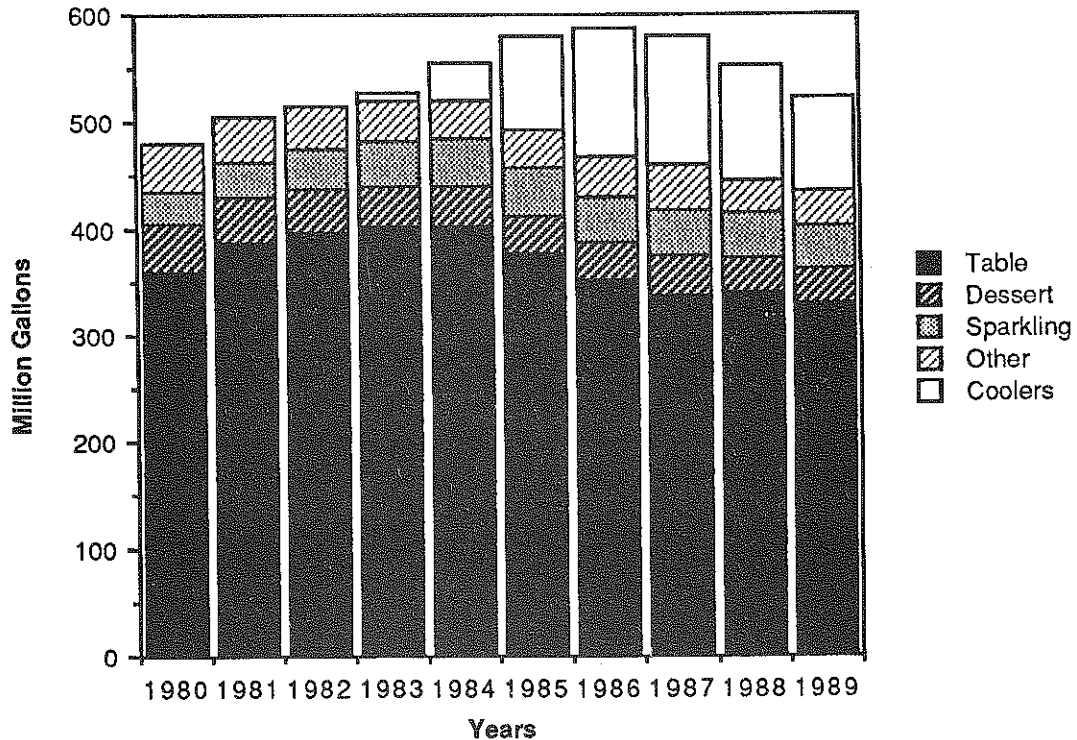

**TABLE WINE ENTERING DISTRIBUTION CHANNELS IN THE U.S.,
BY AREA PRODUCED, 1979-1988 (Million Gallons)**

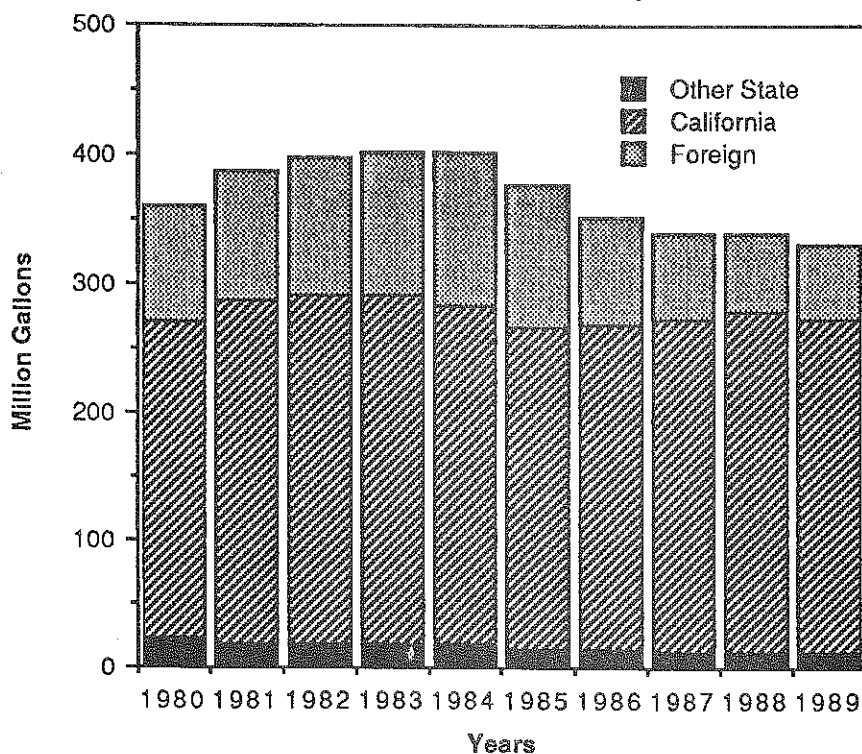

**WINE COOLERS ENTERING DISTRIBUTION CHANNELS IN THE U.S.,
BY AREA PRODUCED, 1980-1989, (Million Gallons)**

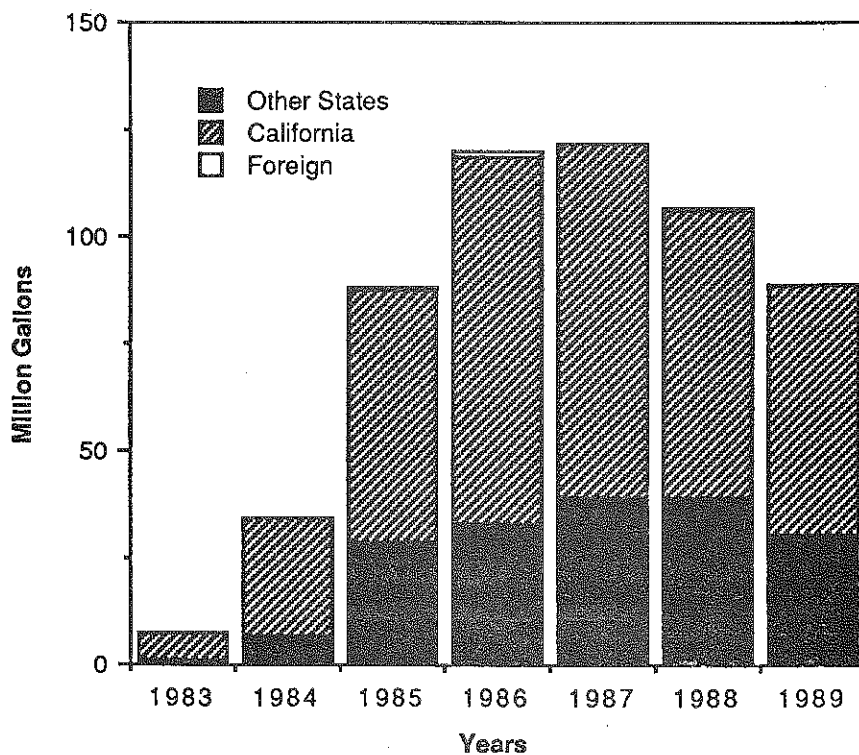

GRAPES: NEW YORK GROWN, RECEIVED BY WINERIES AND PROCESSING PLANTS, 1985-89

Variety	1985	1986	1987	1988	1989
	----- tons -----				
Concord	105,088	107,326	122,688	108,278	100,150
Catawba	7,745	12,262	12,939	11,740	7,887
Niagara	5,614	9,663	10,243	8,262	11,962
Delaware	2,655	5,562	4,722	3,879	3,237
Aurore	5,978	7,794	8,189	6,324	8,507
de Chaunac	2,839	2,911	2,664	1,938	2,474
Baco Noir	1,084	1,419	1,148	797	1,198
Seyval Blanc	1,226	1,514	1,278	1,276	1,181
Rougeon	559	692	788	796	584
Vitis Vinifera (all)	<u>1,364</u>	<u>1,960</u>	<u>1,637</u>	<u>1,853</u>	<u>1,938</u>
Total of all varieties	140,000	159,600	173,500	152,100	148,000

SOURCE: Fruit, New York Crop Reporting Service, 1-85, 1-86, 975-1-87, 975-2-88, and 975-2-89, and New York Agricultural Statistics, 1988-1989.

GRAPES: PRICES PAID FOR NEW YORK GROWN GRAPES PROCESSED, 1985-89

Variety	1985	1986	1987	1988	1989
<u>American Varieties</u>					
Catawba	161	205	233	211*	234*
Concord	164	198	208	213*	235*
Delaware	152	225	266	234	255
Dutchess	138	259	275	259	265
Elvira	203	210	216	204	210
Niagara	173	187	195	188*	232*
<u>French-American Hybrids</u>					
Aurore	195	236	244	232	237
Baco Noir	217	289	283	273	256
Cayuga White	N.A.	N.A.	272	281	347
de Chaunac	162	167	192	183	203
Rougeon	156	245	241	187	215
Seyval Blanc	251	283	289	270	325
<u>Vitis Vinifera</u>					
All varieties	856	925	1,008	990	1,131
Average all varieties	173	211	222	223*	248*

*Preliminary estimates of future payments by cooperatives have been included based upon historical data.

SOURCE: Fruit, New York Crop Reporting Service, 1-86, 975-1-87, 975-2-88, 975-2-89, and 975-2-90.

Concords are the predominant variety grown and processed in New York. There were 100,150 tons of Concords from New York processed in 1989 reflecting a small crop. Over the past five years, Concords have comprised 70 percent of total tonnage utilized. The second leading variety is Catawba with 6.8 percent of tonnage followed by Niagara with 5.9 percent.

Prices for most American and French-American hybrid varieties rebounded in 1986 from a disastrous 1985 season of low prices and low production. Prices for grapes used for juice (mainly Concord and Niagara, as well as some Catawba) have continued to improve. Varieties used mainly in non-premium table wine, such as Delaware and Dutchess, while higher than in 1985, showed little improvement after 1987. Most French-American hybrid prices increased in 1989.

The prices of grapes for fresh use, wine, and juice are shown below. When compared to 10 years before, the prices for all uses were higher in 1989.

In the early 1980's, the price of grapes utilized for wine generally exceeded the price of grapes utilized for juice by \$100 or more per ton. That difference has narrowed in recent years to \$14-\$35 per ton.

In 1990, juice grapes were again in strong demand, with the result that growers with Concord and Niagara grapes received higher prices. Cash prices in excess of \$250 were reported for Concord grapes. National Grape Cooperative, Inc., which processes over 25 percent of New York's total grape production, reported earnings per ton in fiscal year 1990 of \$305 per ton, a new high for its members. The market for red hybrids was stronger than in recent years, but prices for white hybrids, such as Cayuga White and Seyval Blanc, were down, reflecting an average sized crop and probably reduced demand at the winery level. Local demand for vinifera was also somewhat reduced, but the smaller crop and strong out of state markets helped to keep vinifera prices about the same as in 1989, according to David Peterson, Finger Lakes Region Grape Specialist. The market for Riesling continued to be softer than for other vinifera varieties.

AVERAGE PRICE FOR GRAPES IN NEW YORK UTILIZED FOR FRESH GRAPES, WINE, AND JUICE, 1980-1989

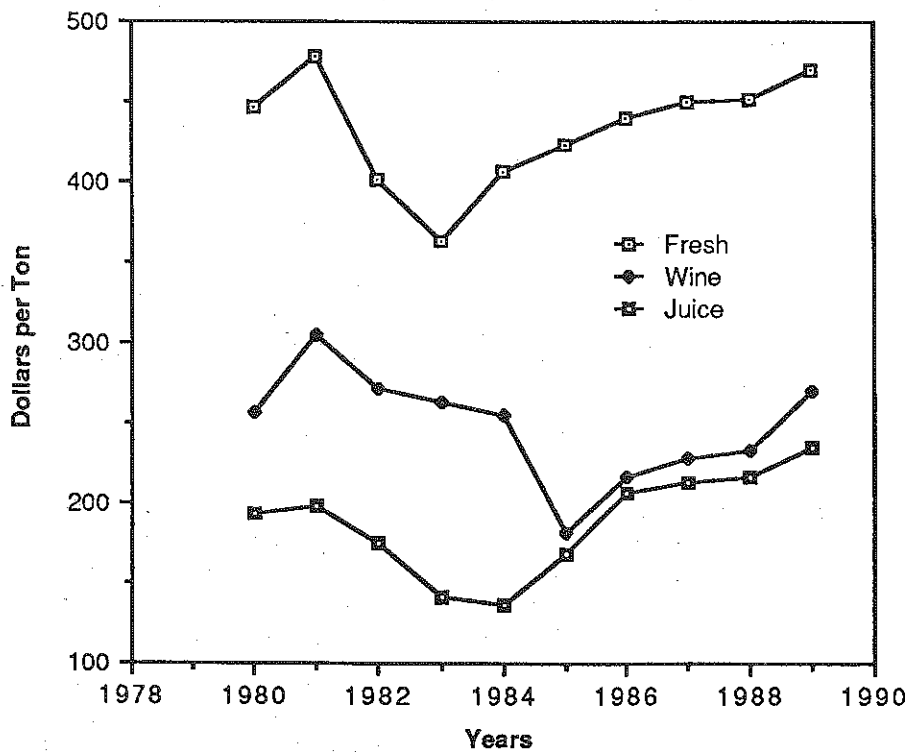

TABLE I.....POTATOES AND VEGETABLES: NEW YORK STATE FARM VALUE OF PRODUCTION, 1984-1989

	1984	1985	1986	1987	1988	1989 ¹	Five-Year Average (1985-1989)
----- millions of dollars -----							
Potatoes:							
Long Island	19.3	11.4	18.0	11.5	16.1	16.8	14.76
Upstate	41.8	28.2	41.3	36.1	44.9	40.9	38.28
Subtotal	61.1	39.6	59.3	47.6	61.0	57.7	53.04
Vegetables:							
Fresh Market	139.8	135.6	167.4	168.4	166.3	191.6	165.86
Processing	33.8	37.6	26.5	30.9	23.7 ²	32.3	30.2
Subtotal	173.6	173.2	193.9	199.3	190.0	223.9	196.06
TOTAL	234.7	212.8	253.2	246.9	251.0	281.6	249.1

¹ Preliminary.

² Includes tomatoes as of 1988.

Sources: New York Agricultural Statistics 1989-1990, New York State Agriculture and Markets, Division of Statistics, June 1990.

Table I presents the latest available figures for potato and vegetable value of production in New York. First, the potato figures indicate that the 1989 crop value did not turn out to be as high as had been predicted last year--prediction was for \$62.0 million, but it only was \$57.7. The 1988 crop was predicted to be \$46.7 million in 1988, but the final tally put the value at \$61.0. Therefore, the USDA chose not to estimate the 1990 crop value until next year. Apparently the changes in estimates were too large to make the initial estimates worth reporting. More of the 1989 crop was marketed earlier during the season. For example, 58% of the Long Island crop was sold by November 30, 1989 and all of the crop was sold by the end of February 1990. The Upstate crop was not as early--43% sold by November 30, 1989 and all the crop was sold by April 30, 1990. The 1989 crop was \$4.5 million dollars lower than the five-year average crop value--an 8.5% drop. The value of New York's 1989 potato crop dropped by 5.4% from 1988, but the national crop value increased by 20.3%! The difference can mostly be attributed to relatively higher prices for the national crop as compared to the New York crop.

Prices for the 1990 New York potato crop averaged \$7.27 per cwt. during August to October and the comparable price for the 1989 crop was \$8.78. Therefore, based on the early prices the 1990 crop value may be lower than the previous year.

New York vegetable value of production was up for both fresh and processed vegetables in 1989. In fact, 1989 was a record year for fresh market vegetable crop value! The fresh market vegetable crop value was 15.5% higher than the five-year average while the processed crop value was up 7.0%. All the major fresh market vegetables increased in value from 1988 except celery. Leading the value of production percentage increases were: green beans by 106.2%; carrots by 65.5%; and strawberries by 33.7%. Also, all the major processing vegetables increased in value from 1988 and the value of green beans increased the most--53.4%. The increase in crop value is attributed to both production and price

increases. With the exception of cabbage, cauliflower and cucumbers all other fresh market vegetables had increased production. Of the major processing vegetables, only beets and tomatoes showed decreases in production.

The 1990 fresh vegetable crop in New York most likely will not surpass the 1989. Though preliminary figures are not available yet, observations and conversations with growers point to a lower crop value. This is particularly true given the very low prices received for Orange County onions and low cabbage prices as well. The 1990 vegetable processing crop (contracted) is up from 1989--9%--and sweet corn increased the most while the snap bean crop was the only one to decline. In fact, contracted sweet corn in New York had the highest percentage increase--84.5%--of any other producing state.

The outlook for the 1991 New York potato and vegetable crop value is better than previous years. Factors such as consumer demand, interregional competition, increased product quality, and relatively stable input (with the exception of fuel costs) prices point in favorable directions for New York producers. One possible negative outcome may be the removal from the market (increased restriction) of certain pesticides. However, this outcome applies to all states and therefore may not uniquely affect New York. In addition, the food safety concern appears to have subsided and concerns about labor availability were ill advised.

TABLE II...U.S. FALL POTATOES: PRODUCTION AND CROP VALUE

	Production				Crop Value			
	1986	1987	1988	1989	1986	1987	1988	1989
	----- 1,000 cwt. -----				----- million dollars -----			
New York:								
L.I.	2,537	2,425	1,992	1,898	18.0	12.5	16.14	16.78
Upstate	5,288	6,250	4,800	4,730	41.2	38.4	44.88	40.92
California	6,887	7,869	6,105	6,440	44.1	32.7	49.76	54.10
Colorado	18,810	19,500	19,040	20,603	79.0	34.1	139.94	172.04
Idaho	90,220	99,710	102,610	102,475	38.9	349.0	554.09	727.57
Maine	21,930	23,240	22,000	22,000	131.6	98.8	160.60	166.10
Michigan	9,625	9,720	7,820	7,350	58.2	49.6	59.04	60.64
Minnesota	13,650	16,330	12,075	13,860	58.0	52.3	74.87	80.39
North Dakota	21,600	24,050	15,525	15,070	90.7	84.2	98.58	96.45
Oregon	23,172	25,924	20,735	23,308	97.0	90.0	99.64	135.74
Pennsylvania	5,160	4,730	3,690	4,715	35.1	28.9	28.04	40.31
Washington	61,950	66,960	63,250	64,310	266.4	244.4	284.63	331.20
Wisconsin	20,125	22,100	20,000	23,120	92.6	85.1	128.0	166.46
Other	16,817	16,190	13,916	14,794	88.0	73.4	89.19	109.85
Total Fall	317,771	344,998	313,558	324,673	1,478.8	1,273.4	1,827.4	2,198.55

Source: Potatoes, Agricultural Statistics Board, National Agricultural Statistical Service, United States Department of Agriculture. September 26, 1990.

Table II presents national fall potato production and crop value. The trend towards lower production levels in Long Island and Upstate continues. The five-year average for fall potato production in Long Island is 2,544,400 cwt and the 1989 crop was 25.4% below the five-year average. A similar trend exists with Upstate production, but at a lower rate. The five-year average production has been 5,488,600 cwt and last year's crop was 13.8% below the five-year average. Contrasting New York fall potato production is national fall potato production. The five-year average for fall potato production has been 330,927,600 cwt. and last year's production was 1.89% below the average. Over the last five years, New York fall potato production has been 1.66% of national production.

In value of production terms, New York's five-year average has been \$53.284 million dollars and last year's production value was 8.3% higher than the five-year average. The national market has averaged \$1,599,090,000 and last year's fall potato production value was 37.49% higher than the five-year average. Not only is New York falling behind in production, but the rate at which the value of the crop has been deteriorating is higher in New York than in other parts of the country. However, New York fall potato production value has been 3.33% of the national crop value and therefore New York potatoes command a relatively higher price than other potatoes.

Idaho, Washington, Colorado, and Wisconsin are the states that have increased fall potato production. Last year, the four states' fall potato production shares of the national market were: 31.6%, 19.8, 6.3%, and 7.1%, respectively for a cumulative share of 64.8%. For the most part, eastern and mid-western fall potato producing states have stabilized their production and therefore the western states have been expanding production to meet the increasing demand.

TABLE III...U.S. STORAGE ONIONS: PRODUCTION AND CROP VALUE

	Production				Crop Value			
	1987	1988	1989	1990 ¹	1987	1988	1989 ¹	1990 ²
	----- 1,000 cwt. -----				----- million dollars -----			
New York	3,132	2,808	2,912	5,376	53.0	40.5	41.8	30.0
Colorado	4,688	5,535	5,520	5,400	45.0	55.8	58.4	
Idaho & Malheur Co.	10,140	9,381	9,288	9,328	82.6	85.3	91.1	
Michigan	1,900	2,000	2,212	2,442	18.9	17.0	17.8	
Oregon	1,512	1,296	1,418	1,365	16.3	11.2	15.1	
Washington	2,300	2,520	2,790	3,060	20.5	19.9	26.7	
Other	1,495	1,326	1,618	1,800	12.6	11.8	13.1	
Subtotal	25,167	24,983	25,826	28,771	248.9	241.5	264.0	
California	10,730	10,512	10,125	12,920	72.8	58.2	74.9	
TOTAL	35,897	35,495	35,951	41,691	321.7	299.7	338.9	

¹Preliminary.

² Estimate.

Source: Vegetables, 1989 Summary. Agricultural Statistics Board. National Agricultural Statistics Service. United States Department of Agriculture. June 1990.

Table III presents U.S. storage onion production. No doubt, the 1990 crop in New York was very large--52% higher than the five-year production average of 3,536,800 cwt. and 85% higher than the 1989 crop. The increased production is attributed to increased yields and increases in harvested acreage. Average New York yields were 420 cwt. per acre--nearly 62% higher than 1989 yields. Harvested acreage in New York was 12% higher than in 1989. At the national level the trend is similar to New York. Harvested acreage increased by 2% and therefore the majority of the increased production also came from increased yields. The 1990 national crop was 14.9% higher than the five-year average of 36,282,600 cwt. In 1990, New York storage onion production represented 12.9% of the national market--the highest share in the last decade. If one excludes California summer production, then New York's share increases to 18.7%.

Unfortunately, the increased production in the state was not a positive outcome. The crop in Orange County was of poor storing quality, but the other producing regions of the state reported good to excellent onions. In fact, Orange county onions deteriorated so quickly during shipment that some receivers refused to receive onions from that county. As a consequence, prices for Orange Co. onions were extremely low--\$2.00 for a 50 lbs. bag. Therefore the estimated value of the 1990 New York crop on Table III is very tenuous. It is very difficult to estimate whether the marketing season will improve for New York onion growers. The five-year national storage onion crop value average has been \$298.7 million dollars and last year's value was 13.46% higher than the five-year average. By contrast, New York's five-year average was \$43.86 million and last year's crop value was 4.7% lower than the five-year average. Given the situation this year, New York's share of the national storage onion market will be precipitous in value terms.

TABLE IV....NEW YORK ONION PRODUCTION BY AREA, 1985-1990

	1985	1986	1987	1988	1989	1990 ¹	Five-Year Average 1986-1990
----- 1,000 hundredweight -----							
Orange*	2,331	1,988	1,652	1,050	1500	2,867	1,811
Orleans-Genesee*	644	650	660	648	315	1,045	664
Oswego*	494	392	458	448	504	819	524
Madison*	173	160	144	140	182	160	157
Steuben-Yates- Ontario	210	182	135	156	288	380	228
Wayne and Other	<u>108</u>	<u>84</u>	<u>83</u>	<u>88</u>	<u>123</u>	<u>105</u>	<u>97</u>
TOTAL	3,960	3,456	3,132	2,808	2,912	5,376	3,481

*Includes seed and set onions.

¹October 12, 1990 estimate.

Source: New York Agricultural Statistics 1989-1990. New York Agriculture and Markets, Division of Agricultural Statistics. June 1990.

Table IV presents a more detailed look at New York storage onion production. Increases in production took place in all counties except Madison and Wayne. The 1990 onion crop increased by 58.3% in Orange Co., 57.4% in Orleans-Genesee, 56.3% in Oswego, and 66.7% in Steuben-Yates-Ontario over the five-year production average.

Orange Co. production represented 53.3% of the state's production--the same share over the last five years.

The future of the onion industry in New York is difficult to predict, but there is no doubt that many in the industry feel that there is no future unless something dramatic happens. First, a milder larger onion needs to be produced. Secondly, a promotional campaign needs to be developed and implemented. The promotion should stress the mildness and keeping quality of New York onions. In addition, the industry needs to consider a market order that will exercise market discipline and generate more funds for promotion and research. Absent of the above, the forces at work in the national onion market will eventually drive New York's onion industry to extinction. The forces are increased demand for larger milder onions, increased production in western states, controlled-atmosphere storage of Vidalia onions, increased promotion by Idaho/Oregon, Texas, Vidalia, and Washington onions, and lastly increased merchandising by New York competitors.

Table V presents in descending order the most valuable vegetable commodities produced in New York. The fifth column, "Ten Year Value Trend (per year)", indicates whether the particular commodity has a ten-year trend--be it positive, zero, or negative. If it is not zero, then the figure is the dollar value per year that the commodity has in/decreased by over the past ten years. Therefore, potatoes, cabbage for kraut, and beets stooped the 10-year downward trend. Last year's figures indicated that the value of production of the above three commodities depicted a ten-year negative trend, but as can be seen from Table V, these year's figures indicate zero growth. Conversely, lettuce was the only commodity that went from a zero growth 10-year trend to a negative (\$323,000 decline per year) growth trend. Fresh market cabbage indicated positive growth last year, but this year's figures indicate a zero growth pattern over the last ten years. And lastly, the ten-year trend for fresh market green beans is \$575,000 per year over the last ten years while it was zero last year.

Last year was the highest value year (past ten) for fresh market sweet corn, fresh market green beans, strawberries, cucumbers, and carrots. In 1989, fresh market green beans surpassed tomatoes while processed green beans surpassed strawberries. Also, cucumbers, processed sweet corn, and carrots passed lettuce in state value of production ranking. In the future, fresh market sweet corn may become the number two vegetable behind potatoes and onion production value may fall to fifth or sixth. The commodities with an apparent brighter future in New York are: fresh market sweet corn, fresh market green beans, strawberries, and cucumbers. At the opposite end of the scale are processed green beans and lettuce--not a bright future in terms of value of production within New York.

The total figure, \$278.327 million dollars, is 11.7% higher than the five-year average. Overall, processed products such as sweet corn and green beans appear to have made a 'rebound'. Over the past five years, New York production of processing vegetables has generally declined, but the decline has abated. Also, strawberries continued to expand in importance and most likely will continue the trend. Lastly, the distribution of the shares (column six in Table V) is widening. That is to say that the top five vegetables in 1988 represented 72% of total vegetable value, but in 1989 the top five vegetables represented only 67.2%. Therefore, New York has a more diverse production base--a positive outcome because risk is spread.

TABLE V.....COMMODITY RANKING OF VALUE OF VEGETABLE PRODUCTION IN 1989

Commodity	Value of 1989 Production	1985-1989 Average Value	Highest Value In Last Ten Years	Ten Year Value Trend(per year)	Value Share in 1989
----- millions of dollars -----					
Potatoes	57.722	54.309	(1983) 76.271	zero	20.7%
Onions	41.823	46.209	(1986) 56.536	zero	15.0%
Cabbage (fresh)	38.955	31.859	(1983) 48.828	zero	14.0%
Sweet Corn (fresh)	29.958	23.898	(1989) 29.958	+0.702	10.8%
Green Beans (fresh)	18.603	9.164	(1989) 18.603	+0.575	6.68%
Tomatoes	16.023	12.953	(1988) 17.434	zero	5.76%
Green Beans (processed)	13.075	12.058	(1982) 17.869	-0.406	4.70%
Strawberries*	11.725	8.944	(1989) 11.725	+0.335	4.21%
Cauliflower	9.511	9.159	(1984) 11.677	zero	3.42%
Cucumbers	8.068	6.649	(1989) 8.068	+0.225	2.90%
Sweet Corn (processed)	6.737	7.819	(1987) 11.005	zero	2.42%
Carrots*	6.674	5.373	(1989) 6.674	+0.178	2.40%
Lettuce	7.134	8.389	(1981) 13.412	-0.323	2.26%
Green Peas (processed)	4.834	5.107	(1985) 8.564	zero	1.74%
Celery*	3.165	3.268	(1981) 4.171	zero	1.14%
Cabbage for Kraut	2.553	2.319	(1981) 3.199	zero	0.92%
Beets	1.767	1.630	(1981) 2.519	zero	0.63%
TOTAL	278.327	249.107			100%

*Includes both fresh and processed.

Source: New York Agricultural Statistics 1989-1990. New York Agricultural Markets,
Division of Statistics. June 1990.

Table VI is presented as a quick reference for individuals interested in national per capita utilization of some of the major vegetables produced in New York. The most dramatic changes are the increased utilization of fresh market onions, the decline in fresh potato utilization, and the drop in canned sweet corn utilization. Another important insight is the almost perfect substitution between canned and frozen snap beans, but the imperfect substitution between canned and frozen sweet corn. The figures for fresh market sweet corn consumption are most likely undercounting. Sweet corn is sold extensively at roadside and/or farmers' markets and these outlets many times are not included in USDA statistics. The figure for fresh market potato consumption during 1988--52.4 lbs--was revised by the USDA.

TABLE VI...PER CAPITA UTILIZATION, IN POUNDS - 1970-1989

Year	Onions (Fresh) ²	Potatoes (Fresh) ³	Snap Beans		Sweet Corn ¹			Total
			Canned	Frozen	Canned	Frozen	Fresh	
1970	12.4	62.3	4.7	1.2	14.3	5.8	7.77	27.87
1971	13.1	56.1	4.6	1.3	14.8	5.5	7.45	27.75
1972	12.6	57.9	4.6	1.4	15.0	5.4	7.77	28.17
1973	12.5	52.4	4.9	1.7	14.5	6.0	7.91	28.41
1974	13.3	49.3	4.9	1.7	13.5	5.9	7.73	27.13
1975	13.4	52.6	4.4	1.4	12.0	6.3	7.77	26.07
1976	13.1	49.4	4.9	1.3	13.1	5.9	8.15	27.15
1977	13.7	50.1	4.8	1.4	14.1	7.4	7.6	29.1
1978	13.6	46.1	4.8	1.4	13.2	6.3	7.3	26.8
1979	14.7	49.6	4.7	1.4	12.5	6.8	7.2	26.5
1980	13.7	51.1	4.5	1.4	12.9	6.4	7.2	26.5
1981	13.0	45.7	4.6	1.7	12.1	6.2	7.1	25.4
1982	15.7	46.8	4.2	1.5	11.4	5.7	7.1	24.2
1983	15.4	49.7	4.0	1.5	11.5	6.6	7.3	25.4
1984	16.2	48.8	3.6	1.8	10.1	7.9	7.6	25.6
1985	16.9	46.7	3.7	1.9	11.7	7.8	7.6	27.1
1986	17.2	49.4	3.8	1.5	11.9	7.5	7.2	26.6
1987	16.8	48.2	3.7	1.7	10.5	7.8	7.4	25.7
1988	18.1	52.4	3.8	1.7	10.1	8.6	6.7	25.4
1989 ⁴	17.9	46.7	3.9	1.9	9.3	7.8	7.5	24.6

¹ On cobb basis.

² Includes California production, which is primarily for processing.

³ Crop year not calendar year.

⁴ Preliminary.

Source: Vegetables and Specialties: Situation and Outlook Report, USDA, Economic Research Service, TVS-251, August 1990.

ORGANIC PRODUCTION

Last year was a year in which many retailers added "organically produced" sections to the produce departments. In fact, some rather large supermarket chains began carrying organically produced vegetables. Many producers felt that the chains were not being realistic about what consumers wanted. This year, many of the stores that carried organic products no longer do so. However, the number of producers who have begun to produce organically has increased. Therefore, the jury is still out as to whether organics will become a permanent part of supermarket produce departments. The traditional outlets for organic produce--health food stores--still say that the demand is higher than product availability.

FARM LABOR

Last year, many producers were concerned about both the availability and cost of hired labor. The labor shortages that were prognosticated did not develop. In fact, labor was available and in some instances growers reported that the quality of labor improved. A report concerning collective bargaining rights for New York agricultural workers will be submitted to the Governor's office in 1991. Most likely the report will not recommend that collective bargaining statutes be enacted, but rather that farm employment be treated as any other type of employment. It will remain to be seen if this recommendation is implemented and thereafter what the implications for farm employers will be.

PESTICIDE RESIDUES

Similar to the organic production issue, pesticide residues on fresh produce received considerable attention from the media and from consumers. However, contrary to the organic issue, this issue is still a concern for the majority of consumers. The greater implementation of Integrated Pest Management (IPM) practices most likely will ameliorate some of the concerns. Unfortunately, "IPM Grown" is not a very attractive marketing approach.

TABLE I...FLOWER DEMAND AND DISTRIBUTION OF RETAIL OUTLETS

PER CAPITA UTILIZATION OF CUT ROSES, CARNATIONS, CHRYSANTHEMUMS, AND TULIPS --1988 A

<u>COUNTRY</u>	<u>STEMS PER PERSON</u>
NETHERLANDS	145
WEST GERMANY	66
UNITED KINGDOM	41
FRANCE	26
NORWAY	15-20
UNITED STATES	14
JAPAN	4

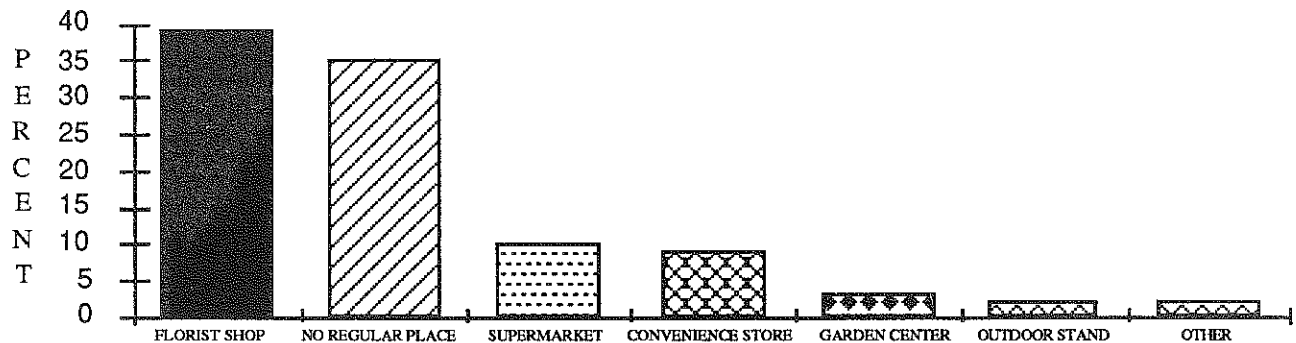
WHERE AMERICA BUYS ITS FLOWERS B

SOURCE A: INTERNATIONAL FLORICULTURE QUARTERLY REPORT, OCTOBER 1989.

SOURCE B: FRESHLINE, PMA, Vol. 22, No. 10, May 18, 1990.

Table I presents two different types of information. The upper half of the Table lists seven countries and their respective per capita utilization of roses, carnations, chrysanthemums, and tulips. The bottom half gives the distribution of retail outlets where Americans buy flowers. The information may have important implications for New York cut flower producers as well as New York cut flower retailers.

New York Hybrid Tea and Sweetheart rose production ranks second nationally behind California production and in 1989 the wholesale value of rose production in New York was \$18,577,000. In fact, New York is the fourth leading cut flower producer in the country--over \$21 million dollars in wholesale value in 1989. Therefore, increasing the demand for cut flowers should

be good news for New York cut flower producers--particularly increasing the demand for high quality cut flowers. Given the information on Table I, is there some strategy that the cut flower industry can embark on to increase cut flower demand?

First, it is obvious that the U.S. could double its' per capita utilization of flowers and still be below countries such as West Germany and the United Kingdom, i.e. potential for market expansion is ample. Secondly, will altering the retail distribution of sales affect the volume of flowers sold? Of late, supermarkets have been increasing their share of retail cut flower sales, but the majority of products sold at supermarkets is the less expensive imported product. Though sales of flowers at supermarkets will continue to expand, this retailing segment does not demand high quality cut flowers. From Table I one can notice the high percentage--35%--of Americans that have "no regular place" where they buy their flowers. Here lies the opportunity for increasing the sales of high quality cut flowers--New York product. The development of "outdoor stand/vendor" and "garden center" retail outlets appears to be an appropriate strategy. In the high consuming countries listed on the upper part of Table I, relatively more product is sold through outlets similar to vendors and/or garden centers. The strategy on increasing sales through these two retail outlets poses a considerable challenge to the industry, but if a sustained effort can be maintained over an extended period of time, more and more Americans will seek these two outlets for high quality cut flowers. Initially, the pricing strategy may need to be amended as well, but once a loyal customer base has been developed the high quality product will sell itself. Obviously coordination throughout the market channel needs to be developed and managed, but the potential for significant increases in sales should guide the industry in pursuing greater sales through garden centers and street vendors.

TABLE II.....SUMMARY OF U.S. FLORICULTURE CROPS WHOLESAL VALUE OF SALES, 1988 AND 1989 - 1,000 DOLLARS

	1988		1989		De/Increase Over 1988 (Percentage)
	Value	Percent of Total	Value	Percent of Total	
Cut Flowers	459,800	20.1%	469,000	19.3%	+ 2.0%
Potted Flowering	506,800	22.1	522,000	21.5	+3.0
Foliage Plants	480,750	21.0	476,000	19.6	- 1.0
Bedding Plants	753,900	32.9	867,000	35.6	+15.0
Cut Greens	90,650	3.9	98,800	4.0	+ 9.0
Total Value	2,291,900	100.0%	2,432,800	100.0%	+6.0

Source: Floriculture Crops - 1990 Summary, U.S. Department of Agriculture, National Agricultural Statistics Service, Agricultural Statistics Board, April 1990.

Table II presents national data on the value of floriculture crops. All the segments increased in value except foliage plants, but the efforts of the Indoor Clean Air Council should stimulate demand

for foliage plants in the future. Bedding plants continue to be the leading segment of the industry and within two years national bedding plants wholesale sales will surpass the \$1 billion mark. The efforts by the Professional Plant Growers' Association--PPGA--(formally Bedding Plants, Inc. [BPI]) can be commended for their contribution to the segment's increased sales. In fact, the data generated by the PPGA national survey have been very useful. Cut flowers increased in value by 2% even though imported cut flowers increased significantly. Potted flowering plants represent the second largest segment and will most likely remain number two because the segment faces relatively lower competition from imports. The industry as a whole increased by \$140.9 million dollars over 1988--representing 6% annual growth. By contrast, the annual growth between 1988 and 1987 was -2.4%.

Table III presents the wholesale value of floriculture products produced in New York. The important changes between 1988 and 1989 that can be observed from Table III are:

- The number of growers increased dramatically.
- The production of cut flowers increased significantly--particularly standard carnations and Hybrid roses.
- The value of standard carnations increased by 2,780%.
- Though production of Pompom chrysanthemums was similar, the value of production dropped by 20%.
- The category of "Potted Flowering Plants increased by 40% with "Finished Florist Azaleas increasing the most.
- Also, Poinsettias' wholesale value increased by over 100%.
- The number of growers of "Foliage Hanging Baskets" increased by over 100 , but total production was flat.
- The value of "Geraniums" increased by 268%.
- Total state floriculture crop value increased by 33.3%.

Next year's Outlook for floriculture products looks bright. This would be particularly true if concerted efforts by industry lead to market expansion. Also, consumer tastes and preferences are slowly shifting to demand more floricultural products. Indoor foliage plants demand may experience a resurgence.

TABLE III.....COMMERCIAL PRODUCERS, QUANTITIES SOLD, AND WHOLESALE VALUE OF SELECTED FLORICULTURE CROPS, NEW YORK, 1989

	Commercial Producers ¹ Number	Quantity Sold	Wholesale Value \$1,000
<u>Cut Flowers</u>			
Carnations			
Standard	19	450,000 blooms	144
Chrysanthemums			
Standard	44	817,000 blooms	626
Pompon	48	229,000 bunches	545
Roses			
Hybrid Tea	26	21,395,000 blooms	14,442
Sweetheart	21	6,035,000 blooms	4,333
Other Cut Flowers	54	-----	1,070
Total			21,160 (+28.1%) ²
<u>Potted Flowering Plants</u>			
African Violets	59	1,462,000 pots	2,433
Chrysanthemums	133	2,413,000 pots	5,954
Finished Florist Azaleas	110	2,228,000 pots	7,015
Easter Lilies	158	586,000 pots	2,346
Other Lilies	69	137,000 pots	729
Poinsettias	263	2,538,000 pots	10,390
Other Flowering Plants	136	1,737,000 pots	6,715
Total			35,582 (+40.4%)
<u>Foliage For Indoor/Patio Use</u>			
Potted Foliage	97	-----	1,935 ³
Foliage Hanging Baskets	267	521,000 baskets	2,860
Total			4,795 (-0.6%)
<u>Bedding Garden Plants (flats)</u>			
Geraniums	155	383,000 flats	4,458
Other Flowering and Foliar Plants	475	3,240,000 flats	22,583
Vegetable Type Plants	410	838,000 flats	6,109
Total			33,150 (+48.1%)
<u>Other Potted Plants</u>			
Hardy Garden Chrysanthemums	211	1,353,000 pots	2,838
Geraniums (cuttings)	376	8,222,000 pots	9,573
Geraniums (seed)	146	2,239,000 pots	3,404
Other Potted and Foliar Plants	216	3,421,000 pots	5,814
Vegetable Plants	122	944,000 pots	1,425
Total			23,054 (+21.7%)
Total of Reported Floriculture Crops			117,741 (+33.3%)

¹ More than \$10,000 in gross sales of all floriculture crops.

² Percentage change from 1988 sales.

³ Net Value, not wholesale value (i.e. less cost of plant material bought)

Source: Floriculture Crops 1990 Summary, U.S. Department of Agriculture, National Agriculture Statistics Service, Agricultural Statistics Board, April 1990.

Situation and Outlook Summary

The 1991 outlook for poultry products in New York and in the country as a whole is brighter for turkeys and cloudy for eggs and broilers. After two very good years in the egg industry, 1991 is likely to be somewhat less profitable. Strong and rising demand for broilers has been outpaced by production. Turkeys are in an adjustment period to slower growth in production after a 50% rise in per capita consumption between 1985 and 1990. The following are the smoothed net returns to the three industries over the last 16 quarters as provided by the USDA.

Smoothed Net Returns 1987-1990

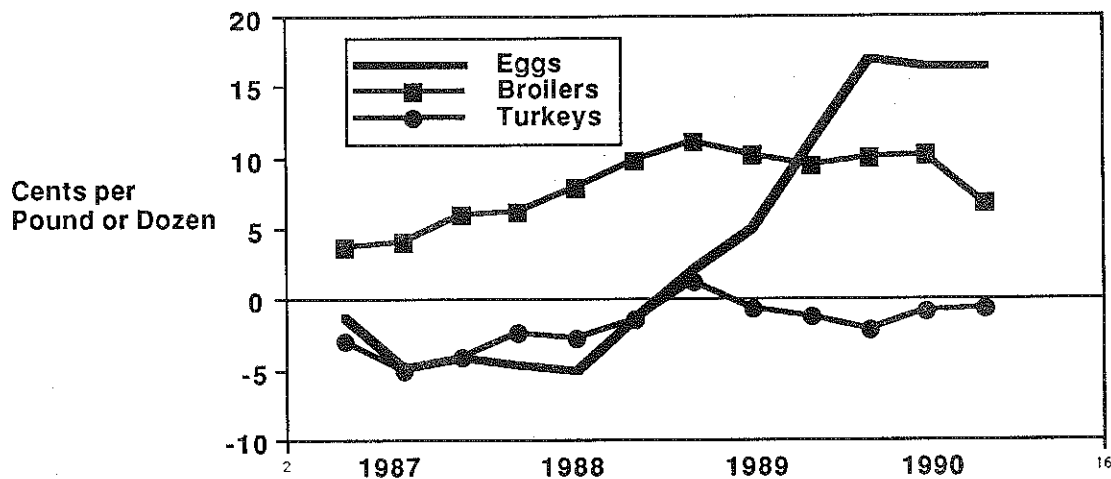

Egg Industry

The egg industry has endured a 40 year long steady erosion in demand which has cut per capita consumption from an unusually high 33 dozen during World War II to just over 19 dozen today. The reasons for this dramatic decline are many but probably the most important is the disappearance of the "American style" breakfast.

Declining per capita consumption and increasing production per hen have brought about periodic downsizings of the national layer flock. This process has been affected almost exclusively by the retirement of the highest cost producers. The year 1989 marked the end of one of the downsizing periods. Since 1989, egg production has been stable and profitable.

As can be seen on the following figure, the New York state flock has declined for the last 20 years from over 10 million in the late 1960's to less than 4 million. In New York, producer retirements played a major role in the decline of flock numbers. Flock and egg producer numbers have now stabilized in the state after the latest period of producer retirements.

In 1991 U.S. production will rise one or two percent in the face of a continuing decline in per capita consumption but production should, nevertheless, remain profitable through the first two quarters at least. New York production is likely to begin a period of expansion at the end of 1991 responding to new marketing opportunities.

Layers On New York Farms

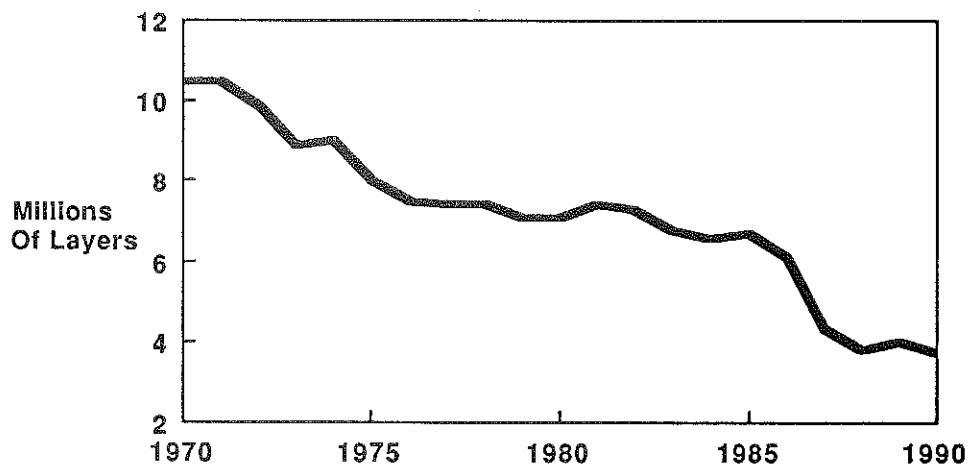

Poultry Meat Industry

In marked contrast to the egg industry, the poultry meat industry has experienced rapid growth during the last 40 years. Broiler per capita consumption has grown from 8 pounds in 1950 to 70 pounds in 1990, exceeding the per capita consumption of beef.

Per Capita Meat Consumption

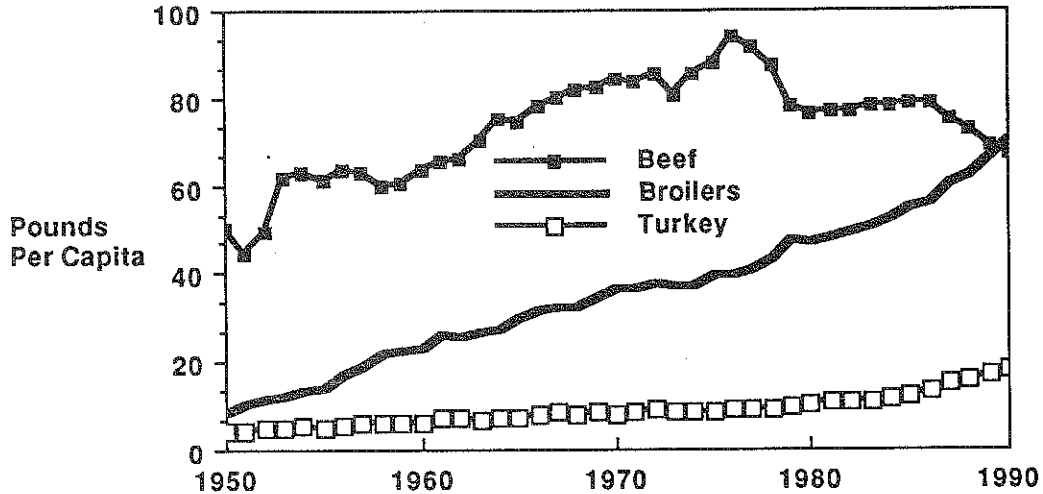

Broiler production during 1991 will grow at a slightly too fast a rate of 5 to 6 percent. Producers will report lower income in 1991 than in 1990 as decreasing consumer income lowers demand for the high profit, further processed items which have driven recent growth in the industry. Slower turkey production increases will lift returns.

Producers in New York have participated somewhat in the increased popularity of poultry meat. Both broiler and turkey production have risen during the 1980's. Long Island duck production is stabilizing after a long decline.

New York Poultry Meat Production

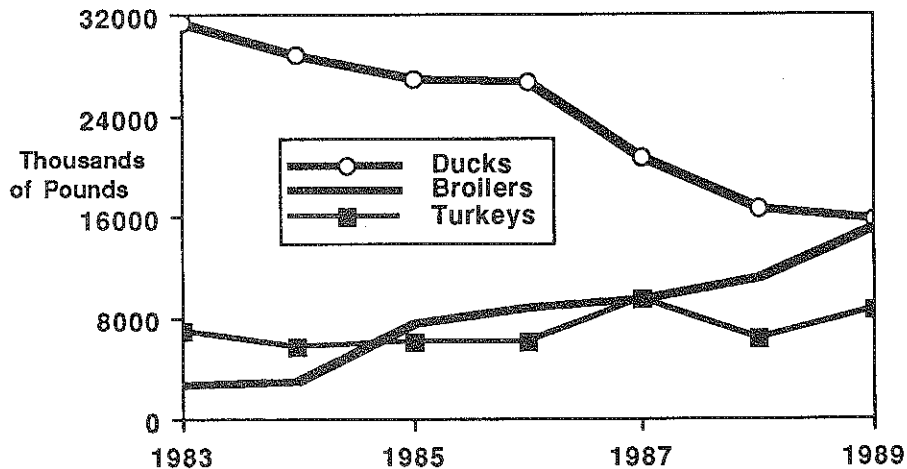

1990 OUTLOOK FOR RED MEAT ANIMALS

Tight supplies of red meat boosted retail beef and pork prices to record levels in 1990. However, the outlook for 1991 livestock prices remains uncertain. Demand for meat products is correlated with disposable income. The Middle Eastern crisis, large federal and state budget deficits and the anticipated economic down-turn have many Americans fearing a severe recession or the return of "stagflation" (a combination of inflation and recession).

These conditions would depress demand for the relatively high priced food items: beef, pork and lamb. Slightly larger red meat supplies are expected in 1991. The Economic Research Service (ERS) forecasts a total two percent increase in 1991 red meat production.¹ Despite uncertain demand and a moderately increasing supply of red meat, prices have remained firm in the three months since the Iraqi invasion of Kuwait. If the expected economic down-turn is not severe or protracted, 1991 beef, veal and pork prices are expected to be near the 1990 levels. A long and serious recession could cause the red meats to lose more market share to poultry due to price differences.

Beef Cattle

The USDA's Economic Research Service reported that 1990 was a pivot year in the cattle cycle. The modest expansion of the cattle herd in 1990 signaled the end of the liquidation phase of the seventh cattle cycle since 1928². The cycle 1979-1989 was an unusual one in that the herd expansion phase lasted only 3 years and the herd expanded only 4.5 % as compared with an average herd expansion of 22 percent over 6 to 8 years. The 1979-1989 herd liquidation phase lasted seven years with a 16 percent decline in the nation's cow herd. This compares to a typical liquidation of ten percent over 3 to 4 years.

In 1990, the national beef cow herd of 34.3 million head was up slightly over the previous year and up one percent over the 1988 level. Figure 1 shows the U.S. Cattle and Calf Inventory in million head from 1930 to 1990. This trend is expected to continue as producers keep back for breeding four percent more heifers in 1990 than '89 and eight percent more than in 1988.³

¹ Livestock and Poultry Situation and Outlook Summary. United States Department Agriculture Economic Research Service. Nov. 14, 1990.

² Livestock and Poultry Situation and Outlook Report. United States Department of Agriculture Economic Research Service. February 1990. LPS-40.

³ Livestock and Poultry Situation and Outlook Report. United States Department Agriculture Economic Research Service. August 1990.

Figure 1. U.S. Cattle and Calf Inventory, Million Head

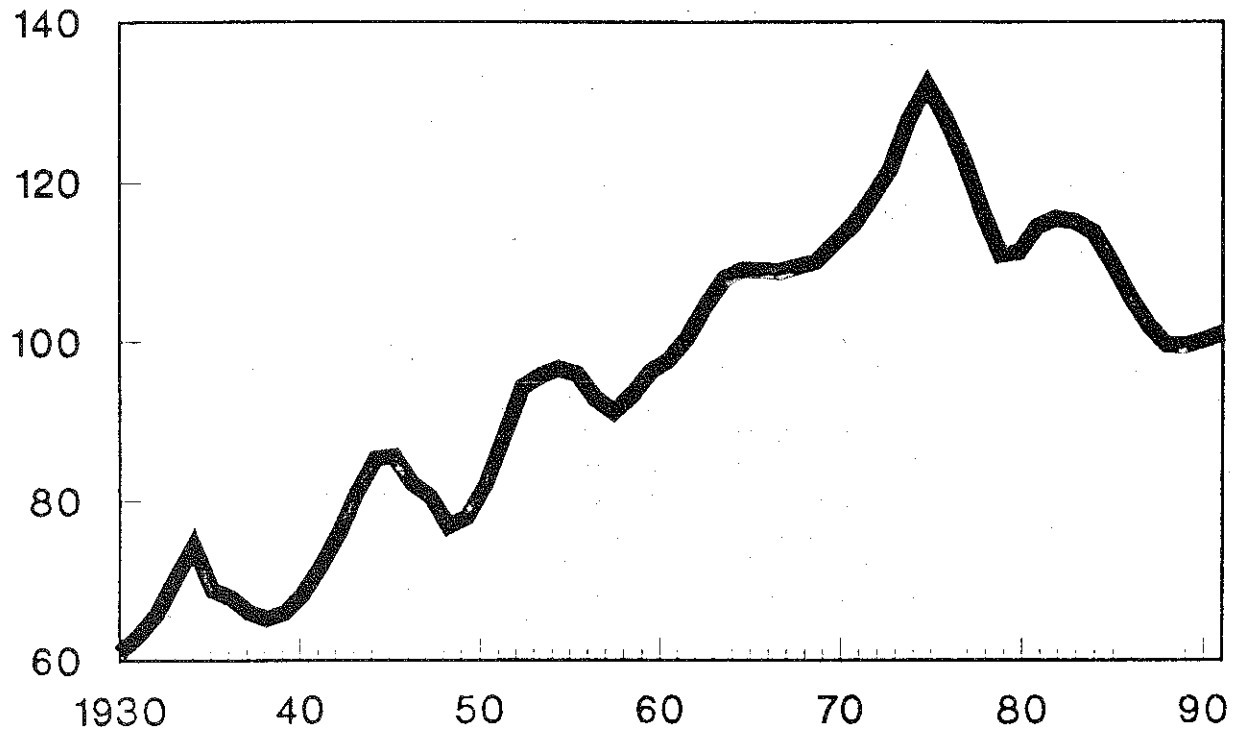

Despite record feeder cattle prices and the fifth consecutive year that cow-calf producers realized positive cash returns, herd rebuilding has been slow and cautious. This is due to several factors. Capital acquisition has been difficult for some producers because of equity and bank problems in major beef producing regions. Drought conditions in many areas resulting in poor forage yields has tended to keep the beef herd sizes down. In the farm financial crunch and tax revisions of the 1980's, 20 percent of cow-calf producers have left the industry. An economic slow-down in 1991 could limit available capital and continue to hold down herd expansion.

The 1990 calf crop is expected to be 40 million head, down fractionally from 1989, figure 2. The 1991 calf crop is expected to be just slightly greater than 1990's. As of October 1, 1990 the number of feeder calves outside feedlots is about the same as last year, but non-fed slaughter has decreased sharply. Even the traditional fall slump in feeder calf prices was smaller than expected this year. October calves were up \$7/cwt over last year's price. Due to continued tight supplies, feeder cattle prices are expected to remain strong well into 1991. Expect feeder and stocker prices to hold up well into the \$ 1.02 to \$1.05 range through March 1991.

Figure 2. United States Calf Crop, Million Head

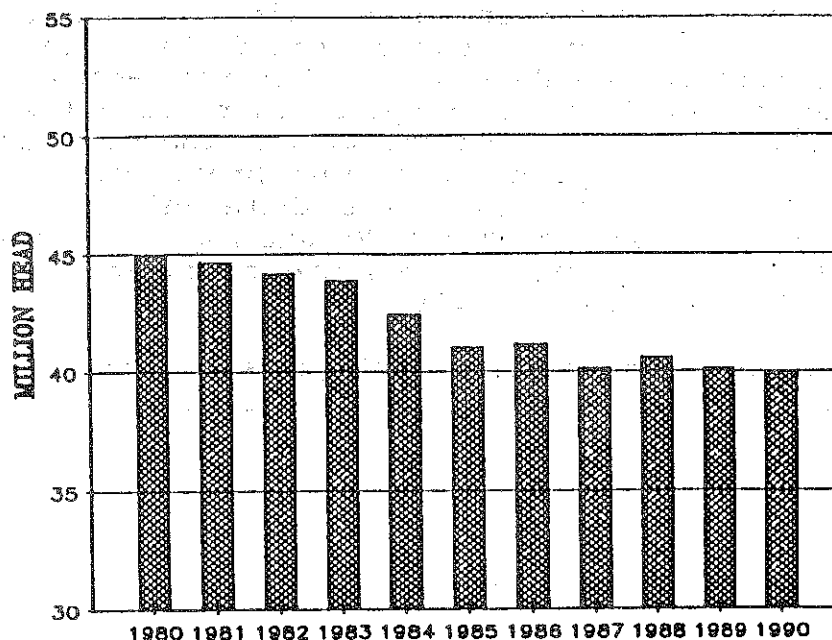

Feed grain and protein feedstuff prices will be lower in 1991 than previously expected due to good yields. Corn prices are projected to range from \$ 2.10 to 2.50/bu. Grain costs to feedlots for 1991 will likely remain unchanged from a year ago. High feeder calf prices and lower than expected feed grain prices will cause continued heavy finished cattle weights as feedlots strive to market more pounds of product with a limited number of animals. Another factor in the unusually large dressing weights is the greater proportion of fed animals in the slaughter mix. Cow slaughter January through September 1990 was six percent below last year's levels.⁴

Through this summer and fall, the larger feedlots took a smaller margin to keep their yards full and operating efficiently. However, these operations might be forced to back down feeder prices if a climbing real interest rate increases their cost of production. The feedlot inventory November 1, 1990 was 109 % of one year ago.⁵ Finished cattle prices will range in the mid to high 70's in 1991. December and February future prices support these estimates. Heavy weight cattle going to market may depress feedlot cattle prices in early 1991.

⁴ Livestock and Poultry Situation and Outlook Summary. United States Department Agriculture Economic Research Service. Nov. 14, 1990.

⁵ Feedstuffs, page 26. Volume 62. No. 47. November 12, 1990

Over the past ten years, beef has lost market share to poultry, figure 3. The shift in consumer preference from beef to poultry is due to a variety of factors including diet and health concerns over fat and cholesterol and consumer demand for convenience foods. However the impact on beef demand from changing tastes and preferences is minor when compared to the response to price differences between beef and poultry. In 1970, beef had 42 % of the total meat market and was priced at 1.3 times pork and 2 times broilers. In 1990, beef is projected to have 31 % of the market share and to be priced at 1.4 times pork and 3.2 times chickens⁶. Recent research indicates that if beef production costs were lowered the consumption response would expand the industry significantly.

Figure 3. U.S. Meat Consumption, Kilograms per capita

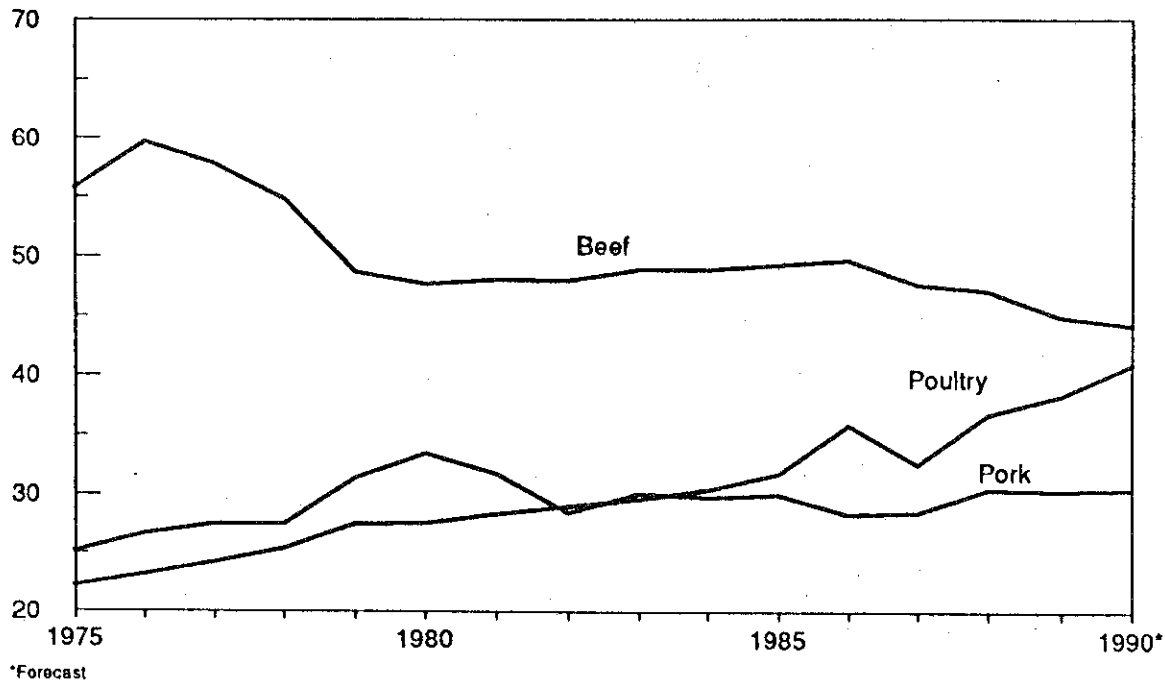

Recent studies indicate that demand for beef has stabilized in response to promotion and research showing that nutritional objections to beef have been overstated. Programs funded by beef check-off dollars have improved the price of fed cattle modestly (\$1.00-2.30/cwt). However, as mentioned above, declining disposable income could move back the demand for beef because of price differences between beef and alternative meats.

⁶ "Task force recommends addressing 'fundamental flaw' in system" Feedstuffs, vol. 4 no. 5. September 24, 1990.

The price for beef is also affected by the world market's supply and demand. U.S. imports of beef and veal declined for the second year in row in 1990 to 2.3 billion pounds (carcass weight) and are expected to decline again in 1991. In 1990, beef and veal exports were slightly below the record 1989 levels. However, 1991 beef and veal exports are expected to expand due to the liberalization of the Japanese market in April 1991. Japan currently accounts for 70 % of the U.S. beef export market. Live cattle exports declined in 1990.

The New York State did not follow the national cow inventory trend. The New York State beef cow inventory, January 1, 1990 was 75,000 cows, five percent lower than the previous year. Beef cows accounted for five percent of all cattle and calves in New York State.⁷ Steer calves going to the New York Teleauction Graded Feeder Sale in October 1990 averaged \$ 87.87/cwt⁸. This price was comparable to the national average of \$ 90.01/cwt for that same week. This demonstrates that graded pre-conditioned, calves pooled into truck lots can be sold at or near national prices.

Hogs

Retail pork prices and live hog prices were strong in 1990. Positive producer returns are expected through most of 1991. However, like beef producers, hog producers have responded cautiously to favorable prices. Even though corn prices were below expected levels at harvest, the relatively small corn inventory could cause price increases if unfavorable weather conditions diminish 1991 yields.

Like cattlemen, the hog farmers are reluctant to make large capital purchases in the face of the current economic uncertainty. As a result of producer's concerns, the number of hogs kept for breeding, 6.9 million head, was about the same September 1, 1990 as the year before. But modest expansion is predicted as producers estimate that they will have 2 percent more sows farrow during September through February than a year earlier. If farmers carry out their expected farrowings and the increase in pigs born per litter trend continues, pork production in 1991 is expected to increase by 3 percent over 1990 levels.

⁷ Cattle. New York Agricultural Statistics Service. April 13, 1990. No. 976-1-90.

⁸ Personal communication. Dennis Widga, New York State Ag. and Markets.

As predicted from actual and predicted farrowings, the commercial slaughter is predicted to be 2 % below 1990 levels in the first quarter of 1991 and 5, 4 and 3 % above 1990 levels in each successive quarter. This trend forecasts strong and steady prices in the first part of 1991 with price declines in the later part of the year. The predicted average 1990 price for barrows and gilts in seven markets is \$55-56/cwt. This is up from \$43.39 in 1988 and \$ 44.03 in 1989. The market price is expected to range from \$50 to \$56/cwt in 1991. In the last quarter of 1991 prices may dip to the high \$ 47-50/cwt range.

The total exports for 1990 are expected to be about 230 million pounds, 13 percent down from the record 1989 level. The European Community stopped accepting pork from US packing plants on Oct. 31 due to perceived sanitary problems. Officials at the Agriculture Department cited the restriction as a flagrant example of a non-tariff trade restriction.⁹ Despite problems in the EEC market, pork exports are expected to increase in 1991 due to increased sales to Japan and Mexico. Total pork imports for 1990 will be about 925 million pounds, 3 percent over 1989. Import predictions for 1991 are for a 5 percent increase to 965 million pounds.

New York State is not a major pork producing region but swine slaughter was 5.4 thousand head in 1989 and 4.2 thousand head in 1990. Prices received by New York producers sending their hogs to three New York markets and Lancaster, Pa. follow national stockyard prices. Depending on local packer and processor demand, regional swine prices vary between \$ 1.50/cwt. below to parity with major market prices.

Sheep

Lamb and mutton production is a small part of total red meat production in the United States. In 1990, the U.S. produced approximately 38.6 billion pounds of meat. Of that number, 363 million pounds or 0.09 percent is lamb and mutton. Nationally, lamb and mutton production increased about 6 percent in 1990. Continued increases in production have kept lamb prices low. Annual production in 1991 is expected to remain level with 1990 production.

In a major reporting market, San Angelo, Texas, slaughter lamb prices have been in the \$52-55/cwt range the last two quarters of 1990, figure 4. This compares to annual averages of \$ 68 and \$ 67 in 1988 and 1989 for the same market. National prices are expected to stay low in 1990 as the breeding flock has not decreased significantly from 1989 and 1990 levels. Prices for slaughter lambs is expected to range in the \$ 53 to \$ 59/cwt range in 1991.

⁹ Beef Business Bulletin. Vol. 14 Number 9. November 2, 1990.

Figure 4. Texas Feedlot Price for Lamb, Guarantee 51% Yield

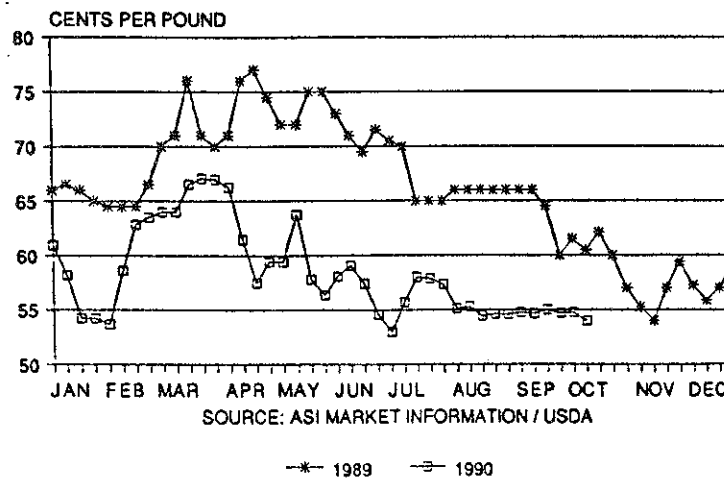

Some analysts cite the small U.S. market and packer concentration for poor lamb prices. The four largest sheep and lamb slaughterers control 77 percent of the market. The federal watchdog, the Packers and Stockyards Administration, a branch of the USDA, has promised farm groups that it is monitoring the situation.¹⁰

New York producers who actively market their lamb have experienced better than national prices because of a quality lamb and low overhead access to consuming markets. New York producers also have the ability to premium price light weight lamb to niche and ethnic markets. Producer run marketing cooperatives in New York State are being successful in developing a local market for quality lambs.

¹⁰ "Farm Bureau Checks Out Packers". The Shepherd. Volume 35 number 11. November, 1990.

1991 DAIRY OUTLOOK

Overview

POSITIVE FACTORS

- Adequate Supply of Good Quality Roughage
- Relatively Strong Cull Cow Market
- Stable Feed Costs
- New Provisions for Federal Orders 1, 2, and 4

NEGATIVE FACTORS

- Sharply Lower Federal Order Milk Prices - down \$2 to \$3
- Eroding Premiums
- Higher Production Input Prices and Hauling Costs - due mainly to higher energy costs
- 5-cent/cwt. Budget Reconciliation Assessment
- Weaker Replacement Cow Prices

UNCERTAINTIES

- RCMA's and Other Cooperative's Ability to Soften Price Drops
- Effect of Sluggish U.S. Economy
- Effect of Lower Dairy Product Prices on Commercial Sales
- Proposal for a new Inventory Management Program
- Producer Response to Refundable Assessments
- Possible Agreements in GATT Negotiations

NEW YORK DAIRY SITUATION AND OUTLOOK
1988, 1989, Preliminary 1990, and Projected 1991

Item	Year				Percent Change	
	1988	1989	1990	1991	89-90	90-91
Number of milk cows (thousand head)	794	776	770	765	-0.8	-0.7
Milk per cow (lbs.)	14,413	14,358	14,655	14,900	+2.1	+1.7
Total milk production (million lbs.)	11,444	11,142	11,284	11,399	+1.3	+1.0
Blended milk price (\$/cwt.) ^a	11.87	13.10	13.42	11.00	+2.4	-18.0
Index of prices paid by dairy farmers	159	168	169	174	+0.6	+1.8

^aNew York-New Jersey blend price, 201-210 mile zone, 3.5 percent fat, this price excludes any premiums or assessments. The effective blend price after milk price assessments is \$11.84 for 1988 and \$13.10 for 1989; and \$13.415 for 1990.

Table 1
U.S. Milk Supply and Utilization
1983-1991

	1983a	1984a	1985a	1986a	1987a	1988a	1989a	1990c	1991d
(billion pounds)									
<u>Supply</u>									
Cow Numbers (thous.)	11059	10793	10981	10773	10327	10226	10123	10148	10127
Production/Cow (lbs.)	12622	12541	13024	13285	13819	14145	14244	14633	14891
Production	139.6	135.4	143.0	143.1	142.7	145.2	144.3	148.5	150.8
Farm Use	2.4	2.9	2.4	2.4	2.3	2.2	2.2	2.2	2.2
Marketings	137.2	132.5	140.6	140.7	140.4	143.0	142.1	146.3	148.6
Beginning Commercial Stocks	4.6	5.2	4.9	4.6	4.2	4.6	4.3	4.1	4.2
Imports	2.6	2.7	2.8	2.8	2.5	2.4	2.5	2.4	2.4
TOTAL SUPPLY	144.4	140.4	148.3	148.1	147.1	150.0	148.9	152.8	155.2
<u>Utilization</u>									
Commercial Disappearance	122.4	126.9	130.5	133.3	135.8	136.8	135.8	140.7	143.1
Ending Commercial Stocks	5.2	4.9	4.6	4.2	4.6	4.3	4.1	4.2	4.2
Net Government Removals	16.8	8.6	13.2	10.6	6.7	8.9	9.0	7.9	7.9
TOTAL USE	144.4	140.4	148.3	148.1	147.1	150.0	148.9	152.8	155.2

Source: Dairy Situation and Outlook, Milk Production, and Dairy Market News, U.S. Department of Agriculture.

a Revised.
 b Preliminary.
 c Based on preliminary USDA data and Cornell estimates.
 d Projected by Andrew Novakovic.

The U.S. Dairy Situation and Outlook

Milk Supplies

Monthly milk production in 1990 was consistently higher than in 1989, but growth rates doubled from the first half to the second half of the year. Cow numbers for the first six months were down slightly from last year, then dropped by over 2% in July, only to rebound the rest of the year. We estimate that the average number of cows in 1990 will increase marginally over 1989. Milk production per cow in 1990 showed substantial monthly increases over 1989 levels, ranging from just under 1% to a whopping 7%. For the year, it is estimated that production per cow will increase by an average of 369 pounds. The combined effect on total production shows 1% to 2% growth in the first six months of 1990 and about a 4% annual gain in the last half. This simple arithmetic is a bit misleading. Although production is undeniably increasing in the last six months, the year to year growth percentages are also very much affected by the fact that milk production was weak during the last half of 1989. Compared to 1988, the seasonal growth in 1990 was much more even, for example.

On a state basis, the news was mixed. California, Washington, Texas and Wisconsin were the only states to follow the national pattern, with year-to-year increases in every month in 1990. Five states--Vermont, Pennsylvania, Ohio, Michigan and New York--began the year with production levels lower than year-earlier levels, but by midyear all had reversed that trend. Iowa started strongly, but by the second quarter began running 1-2% below 1989 production levels. Minnesota's milk production was down 2.5% from January to March, posted a weak recovery of just over one-half percent for the second quarter, and slumped again by nearly 1% from July to September.

For the first three quarters of 1990, milk production was down in Pennsylvania (-2.3%), Minnesota (-0.9%), and Ohio (-0.3%). It was up slightly in New York (0.2%) and Iowa (0.7%) and up moderately in Michigan (2.0%) and Wisconsin (2.3%). The U.S. average was 2.7%. The big gainers are the West Coast states and Texas. California led the pack with an 8.1% increase in milk production. Texas was close behind with a jump of 7.2% over last year, and the gap will likely narrow over the fourth quarter. Washington posted a 4.5% increase.

For 1991, exceptionally low milk prices may result in reduced farms and lower cow numbers nationally, particularly during the second half of the year, but stable to lower feed prices and an ample supply of homegrown feeds from the 1990 harvest should keep production per cow at or above the historical average. As shown in Table 1, our forecast is for cow numbers to decline by 0.2%, production per cow to increase 1.8%, and total production to increase by two billion pounds. A number of forecasters are projecting greater increases.

Milk Utilization

Through August, the USDA reports that commercial disappearance of all milk in 1990 was 4.3% above year earlier levels. As shown in Table 1, our estimate of 140.7 billion pounds for the year would place commercial disappearance 3.6% above 1989, reflecting weakening sales during the last half of the year.

For the first eight months of 1990, commercial disappearance of butter was up 12.9%. This surprising increase is in part a rebound from the 6.1% annual decline estimated for 1989. Possibly, 1989 may not have been as bad as USDA

estimated, and 1990 may not have been quite as good. Given how commercial disappearance is calculated, inconsistencies in how commercial stocks are reported to USDA may be biasing USDA's estimate of how much butter production is reaching commercial markets. Industry does report improved sales of butter that are believed to be the result of lower prices. The disappearance of cheeses was also estimated to be up by 14.6%, with most of the increase in non-Cheddar style cheeses. Fluid milk products showed a marginal rise of 0.6% through August. The real loser has been nonfat dry milk, which has declined by 17.6%. Increased sales of European nonfat dry milk have depressed world prices and pushed the U.S. out of that market, and with ample supplies of farm milk, there is a much reduced domestic demand for powder. Frozen desserts and cottage cheese were down by 1.7% and 3.6% respectively, but within these broad categories lowfat products are doing much better than the average. For example, the fastest growing major dairy product is frozen yogurt.

The traditional way of calculating total disappearance is on the basis of milkfat (the milk equivalent is determined by the amount of milk necessary to yield the milkfat contained in the various dairy products). Changes in the sales of butter and cheese tend to have a great impact on total disappearance. At the other extreme, nonfat dry milk sales have absolutely no impact on the estimate of total disappearance.

For 1991, we project an increase in commercial disappearance of about 1.7%. This primarily reflects our belief that cheese sales will pick up again as current excessive inventories are used up early in the year.

Dairy Price Support Program

Net removals of dairy products under the Dairy Price Support Program (DPSP) are estimated to be over 12% lower than 1989 levels, ending the year at about 7.9 billion pounds (m.e.). This represents just 5.4% of the milk marketed in the U.S., at least when measured on a milkfat milk equivalent basis. Last year our analysis was that net removals were not really as high as the official measure suggested because the milk equivalent measure overemphasized the amount of butter sold to the government under the DPSP. In 1990, a little bit of the reverse is true.

In 1989, sales of butter to the government broke the record set in 1983, with total sales of 422.7 million pounds representing a third of U.S. butter production last year. Butter sales to the CCC as of November 1990 are lagging about 12% behind last year's level. Cheese sales were non-existent until mid-November. In January 1990, sales of nonfat dry milk briefly resumed after a 17-month hiatus and then resumed more seriously in November. On a net basis, the surplus situation in 1990 was probably a bit worse than in 1989: certainly this is true for the end of 1990.

For 1991, no change in milk equivalent net removals is projected, which is to say we don't expect large changes, plus or minus. Butter will still dominate sales to the government, but sales of cheese could be significant early in the year, and nonfat dry milk will be somewhat higher too. The final milkfat based milk equivalent number will be affected by whether surplus milk is sold in the form of cheese or nonfat dry milk and butter.

Milk Prices

As shown in Table 2, farm milk prices in 1990 are estimated to average \$0.10 per cwt higher than in 1989. This masks the real story of 1990, which is the unexpected run-up in milk prices this summer and the collapse that occurred during the fourth quarter. The benchmark M-W price (at 3.5% milkfat) actually peaked in January, after coming off its record high of \$14.93 in December, 1989. It fell to \$12.02 in March and then headed back up to \$13.43 in July. As reports of softening cheese sales and increased milk supplies became more evident in late summer, the bottom fell out of milk prices with a \$2.02 drop in one month (October) and an overall drop from the July peak of about 25%.

For 1991, the benchmark M-W price is expected to stay at or below the support price of \$9.92 (3.5% fat test) for the first several months of the year. The extent to which milk prices strengthen later in the year will hinge on how milk supplies shape up as the year goes on. If milk supplies continue to be more than adequate, the seasonal increase in the fall M-W price may be \$1.00 or less. If these low prices result in farm sales and processors begin to see their supplies threatened, milk prices could rebound to a seasonal peak swing in the M-W of close to \$2.00. Assuming a fairly strong fall, we still estimate national prices to average \$2.00 below the 1990 average. This is more optimistic than the forecasts of many other analysts.

Foreshadowing changes in farm prices, wholesale prices of Cheddar cheese fluctuated erratically, and in September began to drop steeply. For the year, the benchmark price for Cheddar cheese is estimated to be \$1.32 per pound, 2% lower than in 1989 and 21¢ higher than the federal purchase price, but as with milk, the real story is in the changes during the year. The National Cheese Exchange price of 40# block Cheddar peaked at \$1.4675 per pound at the end of July. It slid slowly but steadily through September and then collapsed to 2¢ less than the purchase price in late October, where it has since stayed.

Wholesale prices for butter for the most part hovered around the purchase prices set by the USDA, dipping below them only in February and March. For the year, wholesale prices declined over 5¢/lb. Retail prices are estimated to have declined even further, perhaps 15¢/lb. This is more feasible than it may seem at first because in the past several years wholesale prices have dropped further than retail prices; hence retail prices had room to adjust. Industry reports that butter is being priced very competitively in some stores to take advantage of these much lower wholesale costs. Wholesale prices for nonfat dry milk surged beginning in April, continued strong through August, but moved toward USDA purchase price levels later in the year. For the year, the benchmark wholesale price of nonfat dry milk is estimated to be about \$1.01 per pound, about five cents lower than the average in 1989.

All dairy product prices are estimated to average about a 10% increase over 1989. Whole milk prices may be up as much as 12% and cheese prices slightly more. In contrast to the situation during most of the 1980s, retail price inflation is double or more for dairy products than for all food or all consumer products. Food price inflation should be about 6%, and the expected increase in the general Consumer Price Index is about 5%. Although it appears dairy products became less of a good buy relative to other foods in 1990, this outcome is biased by the higher dairy prices early in 1990 and will not be repeated in 1991.

The 1990 Farm Bill and Beyond

The Food, Agriculture, Conservation, and Trade Act of 1990 was signed into law on November 28, 1990. As with the last several farm bills, this one involved its share of debate and controversy. In most respects, it contains a much simpler dairy program than anything passed in the 1980s, but its simplicity belies the fact that the dairy industry stands precariously at the edge of a very difficult future. The basic parts of the dairy title are as follows.

The support price shall be no lower than \$10.10 per cwt (grade B milk at 3.67% fat test). Provisions exist to trigger an increase in price if net removals are projected to be below 3.5 billion pounds, but it is unlikely that the support price will ever be triggered up. If it never goes up it can never be triggered down. The effect therefore is basically a frozen support price for the next five years.

The accounting for milk equivalent net removals will change from a milkfat to a new "total solids" basis; moreover projected net removals will be adjusted downward for increases in milk equivalent imports, relative to the annual average for calendar years 1986 to 1990. Consequently, the milk equivalent adjusted net removals will look different from the traditional milkfat based measure. Given recent trends, the new figure will almost certainly result in smaller numbers, but the bottom line effect may not be much.

There will be a mandatory assessment program that is actually a part of a recent budget bill, not the farm bill. Under this program, farmers must pay 5¢/cwt on milk marketed in 1991, and 11¢/cwt or more in future years. This assessment has the interesting twist of being refundable if producers decrease their milk sales from one year to the next. For example, milk producers will pay the 5¢ assessment in 1991. After January 1, 1992, they can take proof of sales to their local ASCS office. If their 1991 sales are below their 1990 sales, they can claim a full refund of what they paid during 1991. The assessment in 1992 is scheduled to begin at 11.25¢; however, on May 1, 1992 the USDA will adjust the assessment for the remainder of 1992 to compensate for what was refunded. In every year thereafter, the assessment begins at 11.25¢, but the same process for compensating adjustments is followed.

An additional assessment can be triggered under the farm bill. In this case if net removals are projected to exceed 7 billion pounds (on the new total solids basis, adjusted for increases in imports), farmers will have to pay an assessment to cover the cost of the excess CCC purchases. Our projections suggest that no such assessment would be required in 1991.

Much talk will also be heard in 1991 about a new "inventory management program." The FACT Act requires the Secretary of Agriculture to study certain options and recommend a program to Congress by August 1, 1991. It remains to be seen whether or not USDA will recommend anything that Congress wants to adopt in place of the current program of a frozen support price and assessments above 7 billion pounds.

In a nutshell, the new farm and budget bills won't do too much to hurt dairy farmers, beyond a fairly small assessment, but they don't promise much help for dairy farmers either.

Table 2
Farm Prices for Milk;
CCC Purchase, Wholesale, and Retail Prices for Cheddar Cheese, Butter, and Nonfat Dry Milk;
and Selected Retail Price Indices
1983-1990

	1983	1984	1985	1986	1987a	1988a	1989	1990b
Farm Milk (\$/cwt., ave. fat):								
All Milk	13.58	13.46	12.76	12.51	12.54	12.26	13.56	13.66
Grade A	13.75	13.61	12.90	12.62	12.66	12.34	13.50	13.78
Grade B	12.61	12.49	11.72	11.46	11.37	11.15	12.38	12.36
Milk Price:Concentrate Value	1.72	1.65	1.74	1.79	1.84	1.58	1.65	1.69
Assessment	.48	.50	.13	.37	.19	.03	.00	.01
Cheese (\$/lb.):								
CCC Purchase, Natural Cheddar, Grade A or higher, blocks	1.391	1.348	1.279	1.250	1.219	1.1525	1.166	1.111
Wholesale, Cheddar (40 pound blocks), National Cheese Exchange	1.352	1.341	1.248	1.260	1.213	1.210	1.350	1.320
Retail, Cheddar Cheese (1 lb.)	N.A.	3.065	3.093	3.049	3.056	3.165	3.300	3.750
Butter (\$/lb.):								
CCC Purchase, Grade A or higher, Chicago	1.485	1.433	1.415	1.398	1.373	1.320	1.263	1.017
Wholesale, Grade A, Chicago (1 lb.)	1.473	1.488	1.411	1.445	1.402	1.325	1.277	1.022
Retail, Grade AA, sticks (1 lb.)	2.066	2.107	2.121	2.151	2.170	2.158	2.140	1.990
Nonfat Dry Milk (\$/lb.):								
CCC Purchase, Spray Process, Extra Grade, Unfortified	.937	.910	.843	.808	.783	.728	.774	.831
Wholesale (1 lb.)	.932	.909	.841	.806	.793	.802	1.055	1.006
Retail Price Indices (1982-84=100.0):								
Whole Milks	100.0	100.7	102.3	101.7	103.6	106.0	114.3	168.0
All Dairy Products	100.0	101.3	103.2	103.3	105.9	108.3	115.6	127.5
All Food	99.4	103.2	105.6	109.0	113.5	118.2	125.1	132.5
All Consumer Prices	99.6	103.9	107.6	109.6	113.6	118.3	124.0	130.4

Source: Dairy Situation and Outlook, Dairy Market News, and Federal Milk Order Market Summaries, U.S. Department of Agriculture.

a Revised.

b Estimated by Andrew Novakovic from federal data for part of the year.

Number of Producers Delivering Milk, Simple Average of Months per Year
Northeast Federal and State Marketing Orders
1984-1990

Markets	1984	1985	1986	1987	1988	1989 ^a	1990 ^b
New York-New Jersey	17120	16521	15876	14731	13954	13570	13269
New England	6669	6350	5891	5412	5182	4934	4882
Middle Atlantic	6891	6712	6586	6406	6196	5741	5486
E. Ohio-W. Pennsylvania	6235	6103	5885	5605	5478	5175	4893
Western New York	1258	1211	1161	1088	997	919	852
Regional Total	38887	37922	36902	35353	33242	31807	30347

Source: Annual Federal Milk Order Market Statistics and Annual Statistical Reports for State Orders.

^aRevised.

^bProjected.

Producer numbers in Federal and State order markets declined by 957, or 3.2 percent in 1990 following a 4.6 percent drop in 1989.

Stronger than expected milk prices and stable production costs for much of the year resulted in significantly higher farm incomes and a lower, more normal, producer attrition rate.

During the period from 1984 to 1990 producer numbers in the Northeast orders have declined by 8540 or 22 percent. An average annual decline of 1423 or 3.6 percent.

A further decline of 4 to 5 percent in producer numbers is expected in these markets in 1990, due to sharply lower milk prices and higher production costs.

Receipts of Milk from Producers by Regulated Handlers, Million Pounds
Northeast Federal and State Marketing Orders
1984-1990

Markets	1984	1985	1986	1987	1988	1989 ^a	1990 ^b
	(million pounds)						
New York-New Jersey	11358	11689	11729	11339	11222	11096	11097
New England	5252	5399	5341	5173	5118	4975	5103
Middle Atlantic	5850	6239	6412	6281	6199	5908	5883
E. Ohio-W. Pennsylvania	3669	3866	3884	3842	3920	3687	3540
Western New York	<u>1158</u>	<u>1212</u>	<u>1237</u>	<u>1203</u>	<u>1283</u>	<u>1207</u>	<u>1195</u>
Regional Total	27287	28406	28603	27838	27742	26897	26818

Source: Annual Federal Milk Order Market Statistics and Annual Statistical Reports for State Orders.

^aRevised.

^bProjected.

Total receipts of milk from Northeast milk producers declined modestly in 1990. It was the fourth consecutive year of declining milk receipts for the region. Producer receipts for the four Federal and State order markets were down 0.2 percent or 55 million pounds.

Although receipts declined slightly overall in the region, individual markets varied considerably. Receipts in the E. Ohio-W. Pennsylvania Federal Order were sharply lower due to the shifting of a major distributing plant into a neighboring order outside of the region. Receipts in that market would have been up 1 to 2 percent if the plant had not shifted.

Receipts in the New England Federal Order increased by more than 2.5 percent as milk per farm improved and additional supplies were attracted into that market from neighboring states. Milk receipts in the other three Northeast orders remain relatively stable.

In 1991, receipts in four of the five order markets are expected to increase by 1 to 2 percent, while the E. Ohio-W. Pennsylvania Order will experience a further decline.

Producer Milk Used in Class I by Regulated Handlers, Million Pounds
 Northeast Federal and State Marketing Orders
 1984-1990

Markets	1984	1985	1986	1987	1988	1989 ^a	1990 ^b
	(million pounds)						
New York-New Jersey	4534	4662	4665	4606	4607	4587	4503
New England	2786	2793	2814	2813	2815	2811	2809
Middle Atlantic	2895	2869	2986	3152	3084	3109	3159
E. Ohio-W. Pennsylvania	2019	2033	1985	2023	2052	2033	1924
Western New York	437	443	437	427	495	513	498
Regional Total	12672	12800	12887	13021	13052	13053	12893

Source: Annual Federal Milk Order Market Statistics and Annual Statistical Reports for State Orders.

^aRevised.

^bProjected.

Fluid milk sales in the Northeast order markets were down 1.2 percent or 160 million pounds in 1990 following a slight decline the previous year.

Class I sales declined sharply in the E. Ohio-W. Pennsylvania Federal Order when a major processing plant shifted to an adjoining order. Fluid sales also declined in the New York-New Jersey and Western New York Order markets.

Sharply lower class I sales in the New York City market last January were attributed to adverse newspaper publicity over milk quality testing and product safety. The impact was generally confined to the metropolitan area. Lowfat milk sales are continuing to grow as diet and health conscious consumers switch from whole milk.

Fluid sales for the Northeast orders are expected to remain relatively unchanged in 1991, as recessionary pressures will partially offset the positive effect of lower retail prices for milk.

Producer Milk Used in Class I as Percentage of All Producer Milk Received
by Regulated Handlers
Northeast Federal and State Marketing Orders
1984-1990

Markets	1984	1985	1986	1987	1988	1989 ^a	1990 ^b
	(percent)						
New York-New Jersey	40	40	40	41	41	41	41
New England	53	52	53	54	55	56	55
Middle Atlantic	50	46	47	50	50	53	54
E. Ohio-W. Pennsylvania	55	53	51	53	52	55	54
Western New York	38	37	35	36	39	42	42

Source: Annual Federal Milk Order Market Statistics and Annual Statistical Reports for State Orders.

^aRevised.

^bProjected.

Class I fluid utilization is affected by the volume of fluid sales and total receipts of milk in a market.

Fluid utilization was generally slightly lower in the Northeast order markets during 1991, the Middle Atlantic Order being the only market to register an increase for the year.

In 1991, class I utilization is expected to remain stable to marginally lower in most Northeast markets.

Minimum Class I Prices for 3.5% Milk
Northeast Federal and State Marketing Orders
1984-1990

Markets	1984	1985	1986	1987	1988	1989	1990 ^a
	(\$/cwt)						
New York-New Jersey ¹	14.49	13.97	13.63	13.89	13.41	14.49	15.52
New England ²	14.52	14.00	13.62	13.86	13.38	14.46	15.49
Middle Atlantic ³	15.02	14.50	14.13	14.37	13.89	14.97	16.00
E. Ohio-W. Pennsylvania ³	14.19	13.67	13.20	13.34	12.86	13.94	14.97
Western New York ³	14.95	14.43	14.09	14.35	13.45	14.24	15.27

Source: Annual Federal Milk Order Market Statistics and Annual Statistical Reports for State Orders.

^aProjected.

¹201-210 mile zone.

²21st zone.

³Priced at major city in the marketing area.

Class I fluid milk prices in the Northeast Federal order markets increased \$1.07 per hundredweight or approximately 7 percent in 1990, following a \$1.08 or 8 percent increase in 1989.

A record high Minnesota-Wisconsin price in November and December of 1989 carried over into 1990 to provide record level class I prices in January and February. First quarter fluid milk prices averaged nearly \$2.40 above previous year levels. By contrast, the December 1990 class I price is projected to be \$4.45 below last February's record high price.

In 1991, fluid milk prices in the Northeast order markets are expected to decline sharply, averaging from \$2.50 to \$3.00 per hundredweight below 1990 levels.

Minimum Class II Prices for 3.5% Milk
Northeast Federal and State Marketing Orders
1984-1990

Markets	1984	1985	1986	1987	1988	1989	1990 ^a
	(\$/cwt)						
New York-New Jersey ¹	12.29	11.48	11.30	11.23	11.03	12.37	12.17
New England ²	12.29	11.48	11.30	11.23	11.03	12.37	12.17
Middle Atlantic ³	12.31	11.50	11.32	11.25	11.05	12.39	12.20
E. Ohio-W. Pennsylvania ⁴	12.29	11.48	11.30	11.23	11.03	12.37	12.17
Western New York ³	12.24	11.43	11.25	11.18	10.98	12.32	12.12

Source: Annual Federal Milk Order Market Statistics and Annual Statistical Reports for State Orders.

^aProjected.

¹201-210 mile zone.

²21st zone.

³Priced at major city in the marketing area.

⁴Class III.

In 1990, class II manufacturing milk prices declined 20 cents per hundredweight, or 1.6 percent following an 11 percent increase in 1989.

Based on a recent recommended decision for the New England, New York-New Jersey, and Middle Atlantic Orders, it is anticipated that these markets will have three-class pricing in 1991. Class I will remain the fluid class, class II will include "soft products" such as cottage cheese and sour cream and class III will include the "hard products"; butter, nonfat dry milk and cheese.

In 1991, the class III (currently class II) manufacturing price in the Northeast orders is expected to be sharply lower averaging \$2.00 to \$2.50 per hundredweight or 16-17 percent below 1990 levels.

The new class III price will correspond to the current class II price. The new class II price will average somewhat higher than the class III price, but will not be a constant differential above the class III price in any given month.

Minimum Blend Prices for 3.5% Milk
Northeast Federal and State Marketing Orders
1984-1990

Markets	1984	1985	1986	1987	1988	1989	1990 ^a
	(\$/cwt)						
New York-New Jersey ¹	13.03	12.32	12.09	12.18	11.83	13.10	13.42
New England ²	13.38	12.67	12.43	12.56	12.20	13.45	13.93
Middle Atlantic ³	13.67	12.90	12.66	12.84	12.44	13.75	14.24
E. Ohio-W. Pennsylvania ³	13.35	12.69	12.32	12.37	11.97	13.24	13.84
Western New York ³	13.18	12.47	12.25	12.22	11.94	13.04	13.28

Source: Annual Federal Milk Order Market Statistics and Annual Statistical Reports for State Orders.

^aProjected.

¹201-210 mile zone.

²21st zone.

³Priced at major city in the marketing area.

Northeast order blend prices increased an average 3.2 percent in 1990, following a 10 percent decline in 1989.

When comparing 1990 with 1989, blend prices in the four Federal order markets ranged from 32 cents per hundredweight higher in the New York-New Jersey Order to 60 cents higher in the E. Ohio-W. Pennsylvania Order. The Western New York State Order blend price lagged somewhat due to changes in its pricing provisions the previous year.

Changing market conditions throughout the year resulted in extreme price volatility and counter seasonal price movements. Blend prices fell sharply from January to October, declining by over \$2.00 per cwt. or 14 percent. An additional decline of \$2.00 per cwt. or 15 percent is projected for the last two months of 1990.

Sharply lower blend prices are forecast for the first half of 1991. With all major dairy commodity markets presently at or below support price levels, the Minnesota-Wisconsin price had declined precipitously to near support level by October 1990. The Minnesota-Wisconsin, 3.5% m.f. price is expected to remain at or below support level throughout the first half of 1991.

Blend prices for the Northeast order markets, in 1991, are expected to average from \$2.25 to \$2.75 per hundredweight below 1990, a decline of between 18 and 19 percent.

Most over-order premiums are likely to erode during the first half of 1991, unless cooperative bargaining agencies are able to reach an agreement with handlers on sustainable target price levels.

There will also be a budget reconciliation assessment amounting to 5 cents per hundredweight for calendar year 1991 or its equivalent if collections are over a shorter time period.

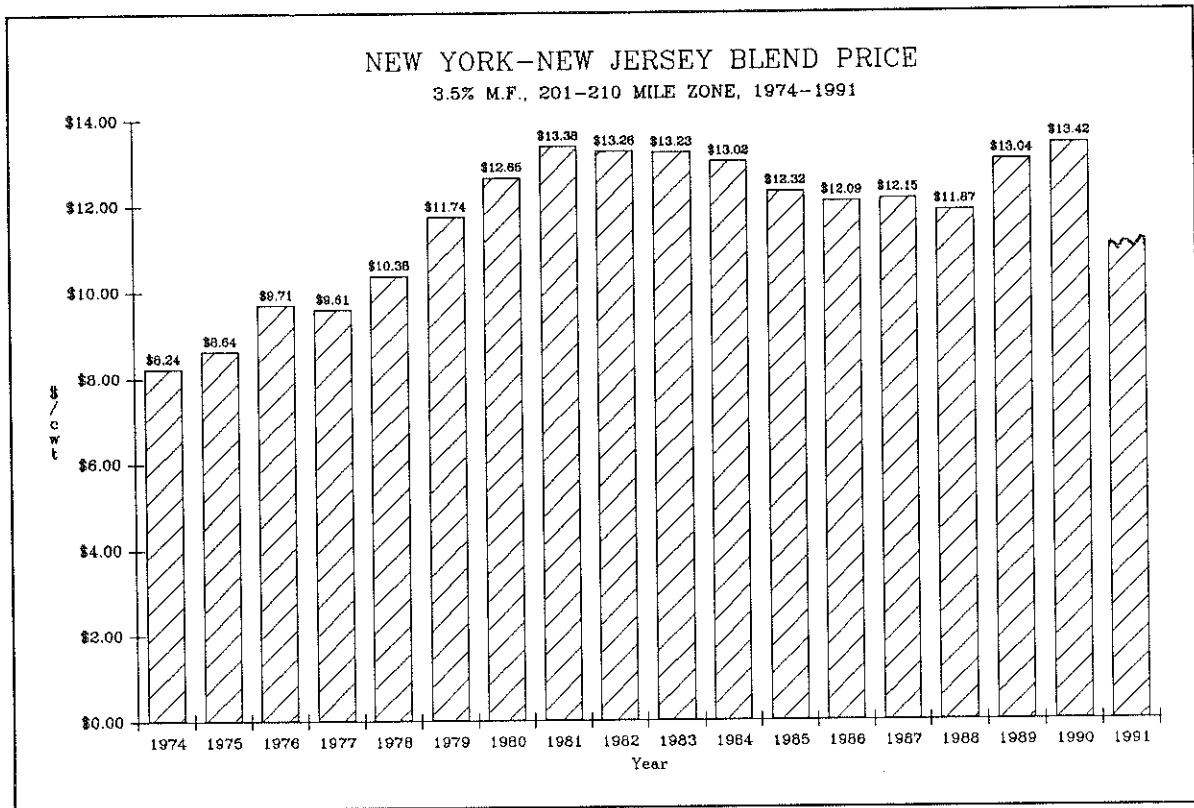

N.Y.-N.J. Blend Price, 3.5% M.F., 201-210 Mile Zone, 1984-1990

Month	1984	1985	1986	1987	1988	1989	1990
January	\$12.99	\$13.34	\$11.92	\$12.76	\$12.03	\$12.95	\$15.17
February	12.79	13.13	11.84	12.42	11.80	12.55	14.22
March	12.55	12.64	11.50	11.92	11.29	11.95	13.45
April	12.36	12.19	11.31	11.55	10.92	11.59	12.75
May	12.26	11.78	11.25	11.30	10.71	11.42	12.83
June	12.29	11.47	11.27	11.35	10.66	11.62	13.25
July	12.84	11.93	11.86	11.96	11.31	12.38	14.02
August	13.39	12.27	12.46	12.44	12.03	13.29	14.43
September	13.74	12.37	12.79	12.75	12.50	14.00	14.27
October	13.83	12.40	13.05	12.80	12.94	14.67	13.10
November	13.91	12.30	13.05	12.69	13.18	15.28	12.43*
December	13.38	12.01	12.78	12.21	13.07	15.47	11.18*
Average	13.03	12.32	12.09	12.18	11.87	13.10	13.42*

*Projected

Source: Price Announcements, Office of the Administrator, New York-New Jersey Milk Marketing Area.

MILK PRICE PROJECTIONS
New York-New Jersey Blend Price, 3.5 Percent, 201-210 Mile Zone
Last Quarter 1990 - First Half 1991

Month	1988	1989	Difference
	(dollars per hundredweight)		
October	14.67	13.10a	-1.57
November	15.28	12.43p	-2.85
December	15.47	11.18p	-4.29
<u>Annual Average</u>	<u>13.10</u>	<u>13.42p</u>	<u>+0.32</u>
	1990a	1991f	
January	15.17	10.96	-4.21
February	14.22	10.84	-3.37
March	13.45	10.52	-2.93
April	12.75	10.36	-2.39
May	12.83	10.22	-2.61
June	13.25	10.24	-3.01
Six Month Average	13.61	10.52	-3.08
Annual Average Blend Price	13.42p	11.00	-2.42
Annual Effective Price*	13.41	10.95	-2.46

*=blend price less Government assessment
a=actual; p=projected; f=forecasted.

Assumptions Associated With These Projections

A support price of \$10.10 per hundredweight for 1991.

A 5-cent per hundredweight budget reconciliation assessment for calendar year 1991.

National milk production up 1.5 to 2.0 percent.

Commercial sales up 1.5 to 2.0 percent.

CCC purchases between 7 and 8 billion pounds m.e., primarily in butter and nonfat dry milk.

Relatively light uncommitted government stocks of cheese and nonfat dry milk.

MILK COWS ON FARMS, NEW YORK, MONTHLY, 1987-1990

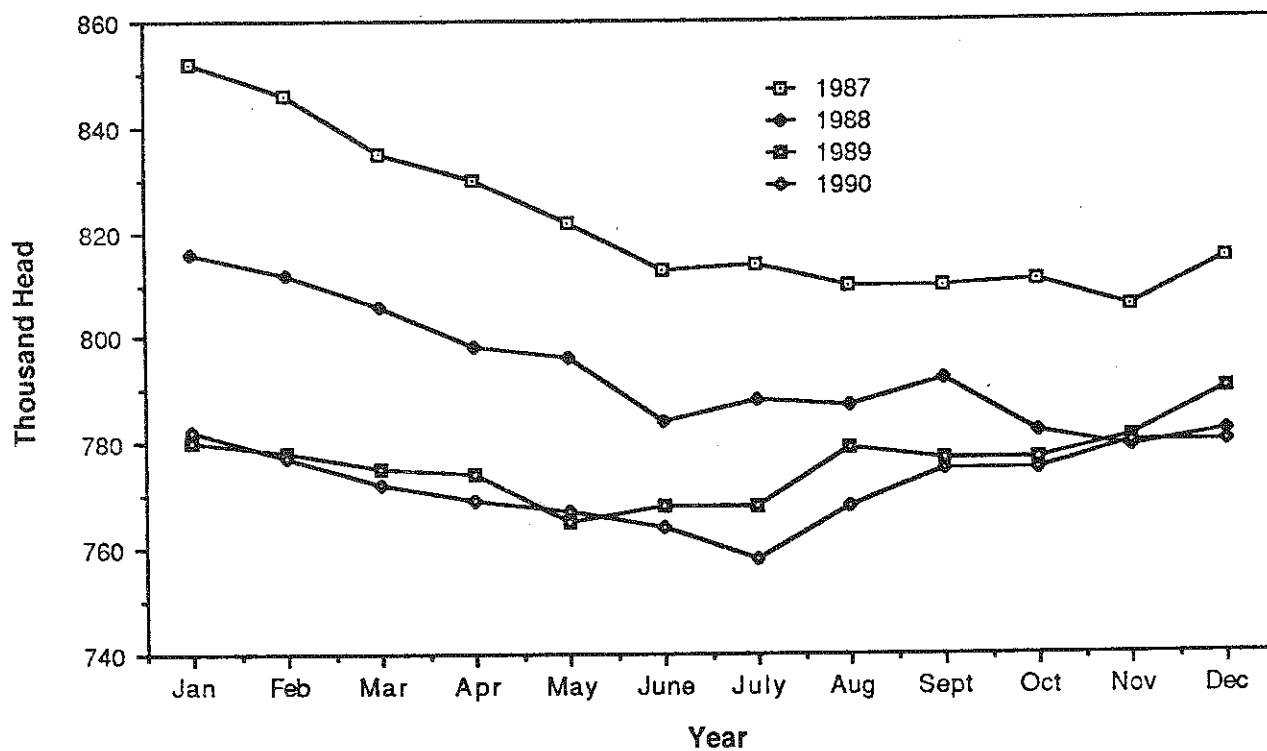

SOURCE: New York Agricultural Statistics.

During most of 1990, monthly cow numbers have been below those during the period from 1985 through 1989. The exceptions are the months of January and May. Monthly cow numbers in New York increased during 1985, followed by a steady decline that began in January 1986 and continued uninterrupted through June 1987. Cow numbers stabilized the second half of 1987, declined through 1988 and stabilized in 1989. In July 1990, the number of cows totaled 758,000, which was the lowest number for any month in New York since monthly records began in 1930. The number of cows in the State is projected to be stable to lower through the remainder of the year.

The U.S. quarterly milk cow numbers have increased in the second and third quarters of 1990 compared to 1989. In the third quarter of 1990, the number of cows in the U.S. averaged 10,144,000. That is 43,000 head more than a year earlier. The Northeast¹ comprised 19 percent of total U.S. milk cows or 1,880,300 head in the third quarter of 1990. This is 62,700 head more than a year earlier. The Northeast accounted for 28 percent of the 1989 to 1990 third quarter U.S. increase in cow numbers.

¹Connecticut, Delaware, Maine, Maryland, Massachusetts, New Hampshire, New Jersey, New York, Pennsylvania, Rhode Island, and Vermont.

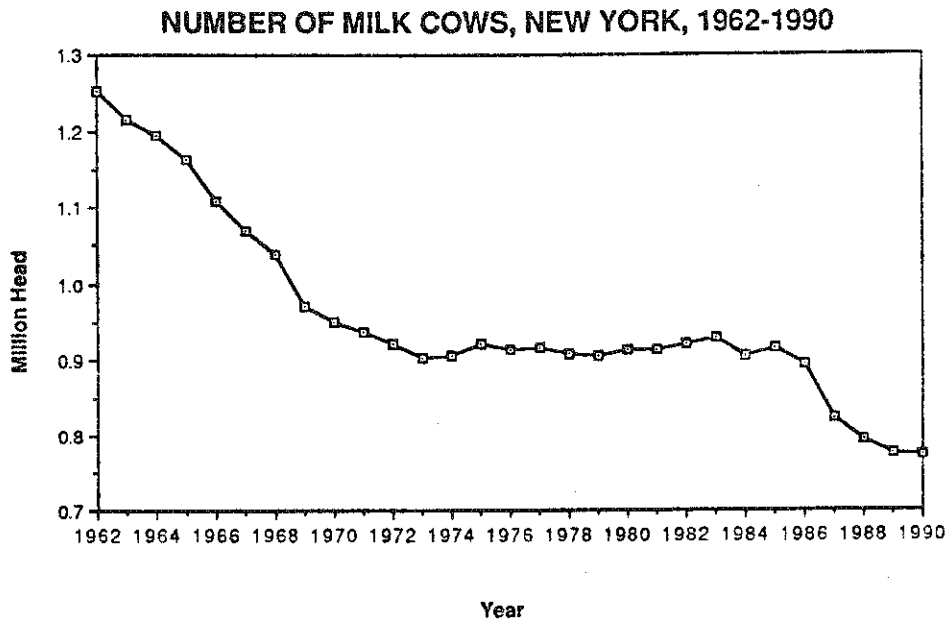

SOURCE: New York Agricultural Statistics.

The average number of milk cows on New York farms for 1990 is estimated at 770,000 head, which is 0.8 percent lower than in 1989. The projected average number of cows for 1991 is 765,000, or down 0.7 percent from 1990.

Heifers on New York farms as a percent of cow numbers on January 1, 1990 increased 1.7 percentage points from 1989 to 40.4 percent. At 319,000 head, milk cow replacement heifers were at the third lowest level in 23 years.

Heifers on U.S. farms as a percent of cow numbers was 42.6 percent in January 1990, a 1.4 percentage point increase from 1989. July 1990 U.S. heifers as a percent of cow numbers was also 42.6 percent, 2.0 percentage points above July 1989.

<u>Year</u>	<u>New York Milk Cows, Annual Average</u>	<u>New York Milk Cows, January</u>	<u>New York Heifers, January</u>	<u>Heifers as Percent of Cow Numbers</u>
	----- thousand head -----			percent
1980	911	910	356	39.1
1981	912	915	348	38.0
1982	919	920	403	43.8
1983 ¹	928	932	435	46.7
1984 ¹	904	925	420	45.4
1985 ¹	914	910	425	46.7
1986 ¹	894	925	388	41.9
1987 ¹	822	855	355	41.5
1988 ¹	794	816	290	35.5
1989 ¹	776	780	302	38.7
1990 ²	770	790	319	40.4
1991 ³	765	--	--	--

¹Revised ²Preliminary ³Projected
 SOURCE: New York Agricultural Statistics

ANNUAL MILK PRODUCTION PER COW, NEW YORK, 1962-1990

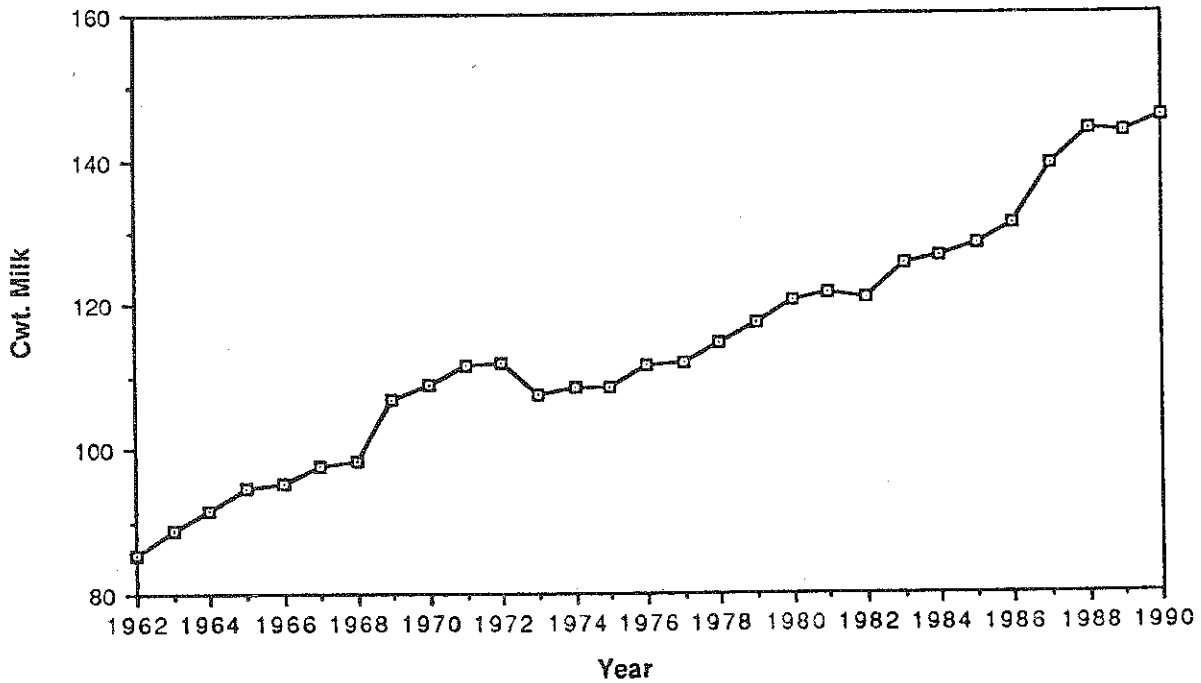

SOURCE: New York Agricultural Statistics.

Pounds of milk produced per cow in 1989 was down 0.4 percent from 1988. Milk per cow is expected to average 14,655 pounds in 1990, an increase of 2.1 percent over 1989. Milk production per cow has increased steadily since 1960 with the exception of 1973 and 1974 and small declines in 1982, 1984, and 1989.

Milk production per cow is projected to increase in 1991 by 1.7 percent. Based on continued genetic improvements and reduced number of cows, milk per cow is projected to reach 14,900 pounds in 1991.

Year	N.Y. Milk Production Per Cow pounds	Mixed Dairy Feed 16% Protein ¹ \$/ton	New York Milk-Feed Price Ratio ¹	New York All Hay, Baled ² \$/ton	U.S. Milk Production Per Cow pounds
1980	12,046	180	1.45	58.00	11,891
1981	12,137	194	1.42	69.00	12,183
1982	12,075	177	1.55	77.00	12,306
1983 ³	12,552	193	1.42	82.00	12,585
1984 ³	12,658	194	1.39	81.50	12,503
1985 ³	12,836	164	1.56	75.50	12,994
1986 ³	13,107	163	1.55	70.50	13,260
1987 ³	13,916	153	1.66	72.00	13,819
1988 ³	14,413	181	1.39	75.50	13,145
1989 ³	14,358	189	1.51	76.50	14,244
1990 ⁴	14,655	177	1.69	--	--
1991 ⁵	14,900				

¹1980-1985 is New York, 1986-1990 is Northeast.

²Season average, June through May.

³Revised

⁴Preliminary

⁵Projected

TOTAL MILK PRODUCTION, NEW YORK, 1962-1990

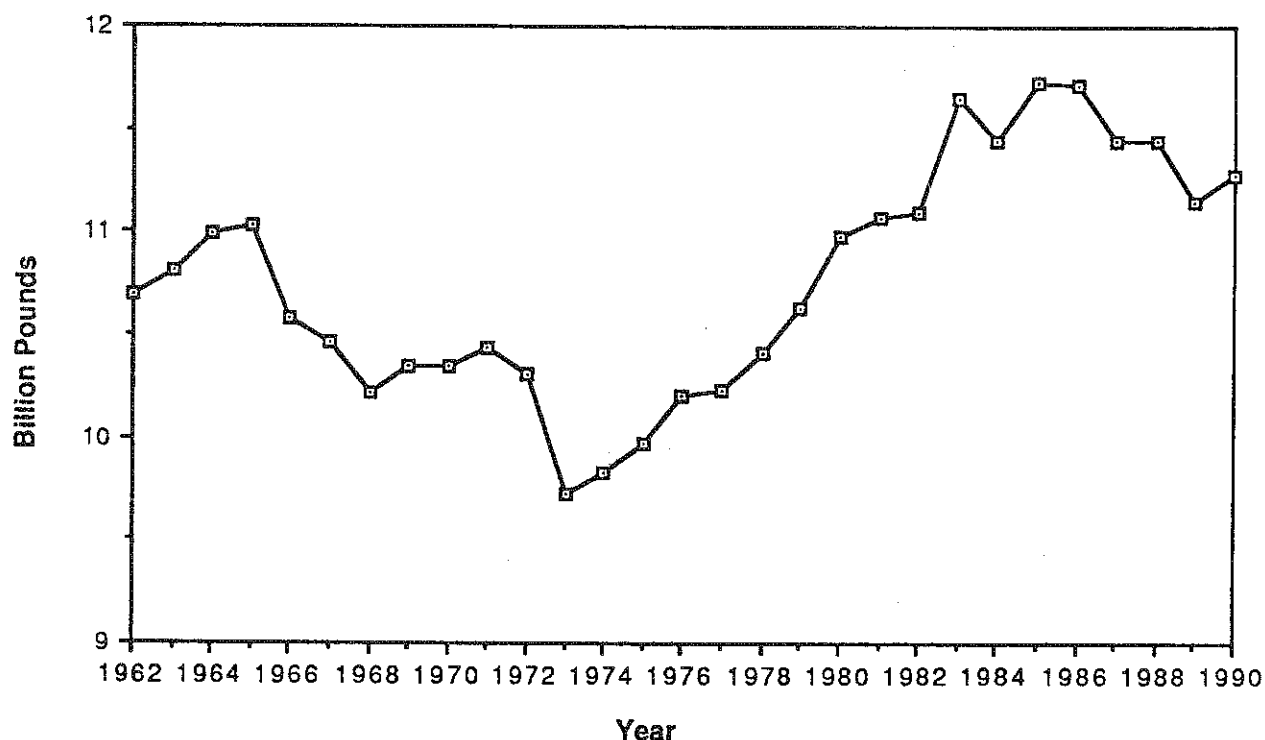

SOURCE: New York Agricultural Statistics.

Total New York milk production in 1990 is estimated at 11,284 million pounds, up 1.3 percent from 1989. This increase is entirely due to the 2.1 percent increase in production per cow since cow numbers are down 0.8 percent.

Total milk production is projected to increase 1.0 percent in 1991 to 11,399 million pounds. This is a result of the factors discussed on the previous two pages in regard to cow numbers and production per cow.

United States total milk production was 144,252 million pounds in 1989. It is estimated that 1990 production will be 148,500 million pounds, 2.9 percent above 1989 production.

Year	Total Milk Prod.		NY as % of U.S.	Year	Total Milk Prod.		NY as % of U.S.
	New York million pounds	U.S. million pounds			New York million pounds	U.S. million pounds	
1980	10,974	128,525	8.5	1986 ¹	11,718	143,124	8.2
1981	11,069	133,013	8.3	1987 ¹	11,439	142,709	8.0
1982	11,097	135,795	8.2	1988 ¹	11,444	145,152	7.9
1983 ¹	11,648	139,588	8.3	1989 ¹	11,142	144,252	7.7
1984 ¹	11,443	135,351	8.5	1990 ²	11,284	148,500	7.6
1985 ¹	11,732	143,012	8.2	1991 ³	11,399	150,800	7.6

¹Revised

²Preliminary

³Projected

MILK COW PRICES, NEW YORK, ANNUAL AVERAGE, 1970-1990

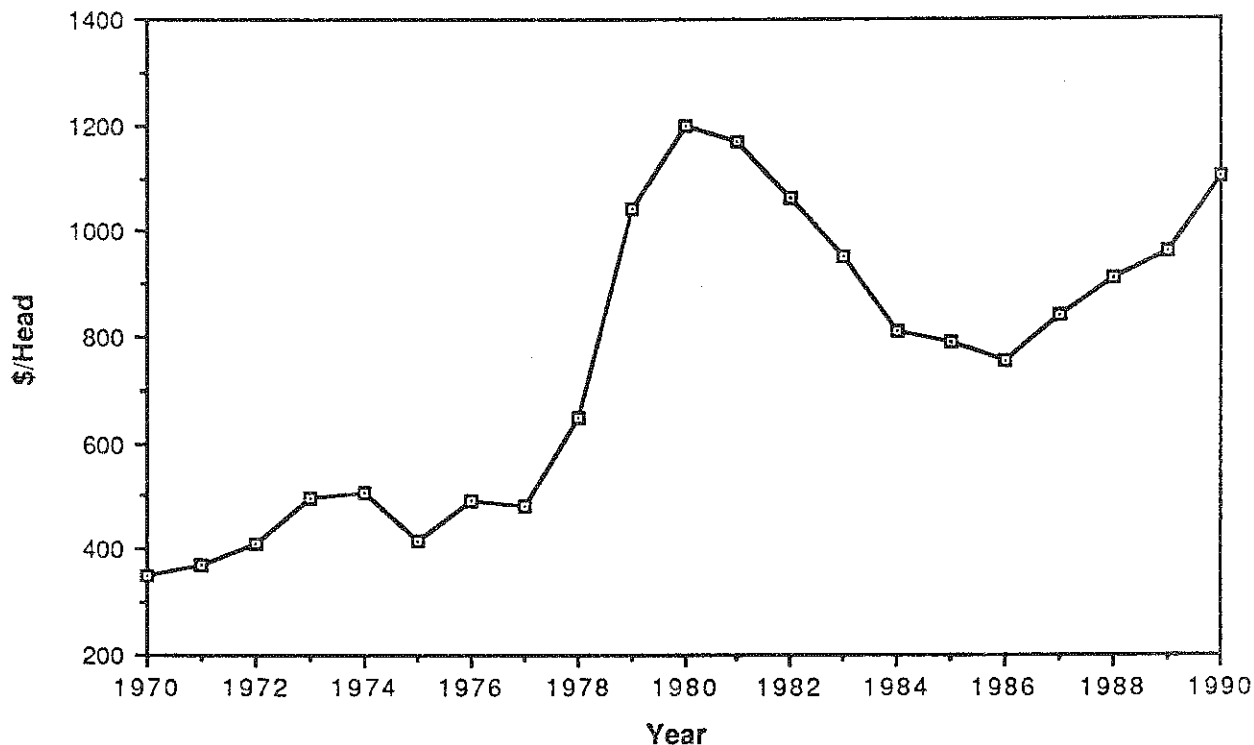

SOURCE: New York Agricultural Statistics.

Milk cow prices increased through the first quarter of 1989 to \$960 per head in March and April, remained at that level through the third quarter, and increased to \$1,020 in the last quarter. In 1990, milk cow prices increased in the first quarter, remaining level through the second quarter, and increased to \$1,160 per head in October, the highest milk cow price since 1981. Monthly prices for milk cows have averaged \$140 a head higher than a year earlier. Slaughter cow prices are stronger and averaged \$4 per hundredweight higher than a year earlier. Calf prices averaged about \$10 per hundredweight higher in 1990 compared to 1989.

Month	Milk Cows, \$/Head		Slaughter Cows, \$/Cwt		Calves, \$/Cwt	
	1989	1990	1989	1990	1989	1990
January	\$ 920	\$1,050	\$45.10	\$48.90	\$ 96.00	\$105.00
February	930	1,070	46.60	48.60	105.00	102.00
March	960	1,070	45.00	48.70	93.30	94.00
April	960	1,070	44.70	48.80	103.00	119.00
May	950	1,070	46.00	50.00	119.00	124.00
June	960	1,080	46.10	51.70	105.00	121.00
July	960	1,100	45.80	50.70	88.70	108.00
August	950	1,130	45.70	50.30	87.90	106.00
September	960	1,140	46.10	50.00	99.50	110.00
October	990	1,160	44.90	48.00	97.00	101.00
November	1,010		44.80		94.70	
December	1,020		48.60		101.00	

INDEX OF PRICES PAID BY NEW YORK DAIRY FARMERS
(1977=100)

Item	Weight	1985	1986	1987	1988	1989	1990 ¹	1991 ²
Feed	.31	119	119	112	133	139	128	129
Purchased animals	.03	163	156	173	188	198	227	200
Fuel & energy	.05	204	184	176	184	193	220	250
Fertilizer	.05	134	127	128	139	144	140	147
Seed	.02	169	167	166	171	181	184	185
Machinery	.18	185	185	189	198	208	217	225
Building & fencing supplies	.08	136	136	137	138	141	144	148
Farm services & rent	.08	151	150	146	147	158	163	168
Agricultural chemicals	.01	128	127	124	127	132	139	146
Interest rates	.07	147	140	125	126	141	135	136
Farm wage rates	.09	170	183	195	209	221	235	245
Property taxes	.03	176	181	175	181	186	190	195
Prices Paid, Not Including Assessment		150	149	149	159	168	169	174
Prices Paid, Including Assessment		152	154	150	--	--	--	--

¹Preliminary ²Projected

SOURCE: New York Agricultural Statistics Service

The preliminary 1990 index of prices paid by New York dairy farmers is 169, a 0.6 percent increase from the 1989 index of 168. All component items in the index, except feed, fertilizer, and interest rates, increased in 1990. Purchased animals showed the largest increase at 15 percent, followed by fuel and energy with a 14 percent increase, and farm wage rates with a six percent increase. The feed component decreased eight percent. The index had been very stable from 1985 through 1987; but every component item increased in both 1988 and 1989.

Feed prices are expected to increase slightly in 1991 assuming a "normal" 1991 crop year. Dairy cow prices are expected to decrease substantially due to unfavorable milk-feed price ratios which will more than offset continued strong slaughter cow prices.

Fuel and energy prices are projected to increase substantially in 1991 from the average levels of 1990.

Seed prices are expected to be about the same in 1991. Fertilizer and chemical prices are expected to increase as a result of higher oil and energy prices. Interest rates paid by farmers are expected to be about the same in 1991.

The 1991 index of prices paid is projected at 174, up about three percent from 1990.

COMPARISON OF DAIRY FARM BUSINESS DATA BY REGION
420 New York Dairy Farms, 1989*

Item	Region**			
	1	2	3	4
Number of farms	145	91	73	111
<u>ACCRUAL EXPENSES</u>				
Hired labor	\$ 19,169	\$ 61,339	\$18,861	\$ 21,455
Feed	60,799	110,256	60,178	61,408
Machinery	19,225	38,134	18,750	20,946
Livestock	24,454	46,522	23,706	32,731
Crops	13,388	29,690	12,959	14,714
Real estate	12,808	24,252	12,651	15,157
Other	26,000	52,656	29,149	29,682
Total Operating	\$175,843	\$362,849	\$176,254	\$196,093
Expansion livestock	639	7,070	2,153	1,108
Machinery depreciation	12,822	21,962	14,268	12,546
Building depreciation	6,955	15,545	6,541	6,998
Total Accrual Expenses	\$196,259	\$407,426	\$199,216	\$216,745
<u>ACCRUAL RECEIPTS</u>				
Milk sales	\$206,984	\$429,021	\$209,780	\$224,509
Livestock	19,948	51,450	22,311	20,326
Crops	3,383	3,553	5,006	2,275
All other	5,799	11,566	5,866	5,990
Total Accrual Receipts	\$236,114	\$495,590	\$242,963	\$253,100
<u>PROFITABILITY ANALYSIS</u>				
Net farm income (w/o appreciation)	\$39,855	\$88,164	\$43,747	\$36,355
Net farm income (w/appreciation)	\$61,920	\$117,884	\$65,914	\$62,928
Labor & management income	\$18,728	\$54,993	\$23,875	\$10,767
Number of operators	1.34	1.52	1.37	1.42
Labor & management income/operator	\$13,976	\$36,179	\$17,427	\$7,582
<u>BUSINESS FACTORS</u>				
Worker equivalent	2.91	4.63	2.96	2.95
Number of cows	86	162	88	90
Number of heifers	67	131	72	71
Acres of hay crops***	151	179	171	165
Acres of corn silage***	57	140	70	69
Total tillable acres	267	476	287	297
Pounds of milk sold	1,431,388	2,978,961	1,470,681	1,496,965
Pounds of milk sold/cow	16,734	18,425	16,692	16,601
Tons hay crop dry matter/acre	2.6	2.9	2.4	2.6
Tons corn silage/acre	12.8	13.3	14.2	13.5
Cows/worker	29	35	30	31
Pounds of milk sold/worker	492,606	642,763	496,652	507,497
Percent grain & conc.				
is of milk receipts	28%	25%	27%	26%
Feed & crop expense/cwt. milk	\$5.16	\$4.67	\$4.93	\$5.07
Fertilizer & lime/crop acre	\$27.37	\$32.38	\$25.97	\$27.90
Machinery cost/tillable acre	\$139	\$144	\$134	\$131

*Includes 11 dairy cash-crop farms.

**See the map on the following page.

***Average of all farms in the region, not only those producing the crop.

Percent Increase in Milk Production,
Four Regions in New York,
1979-1989.

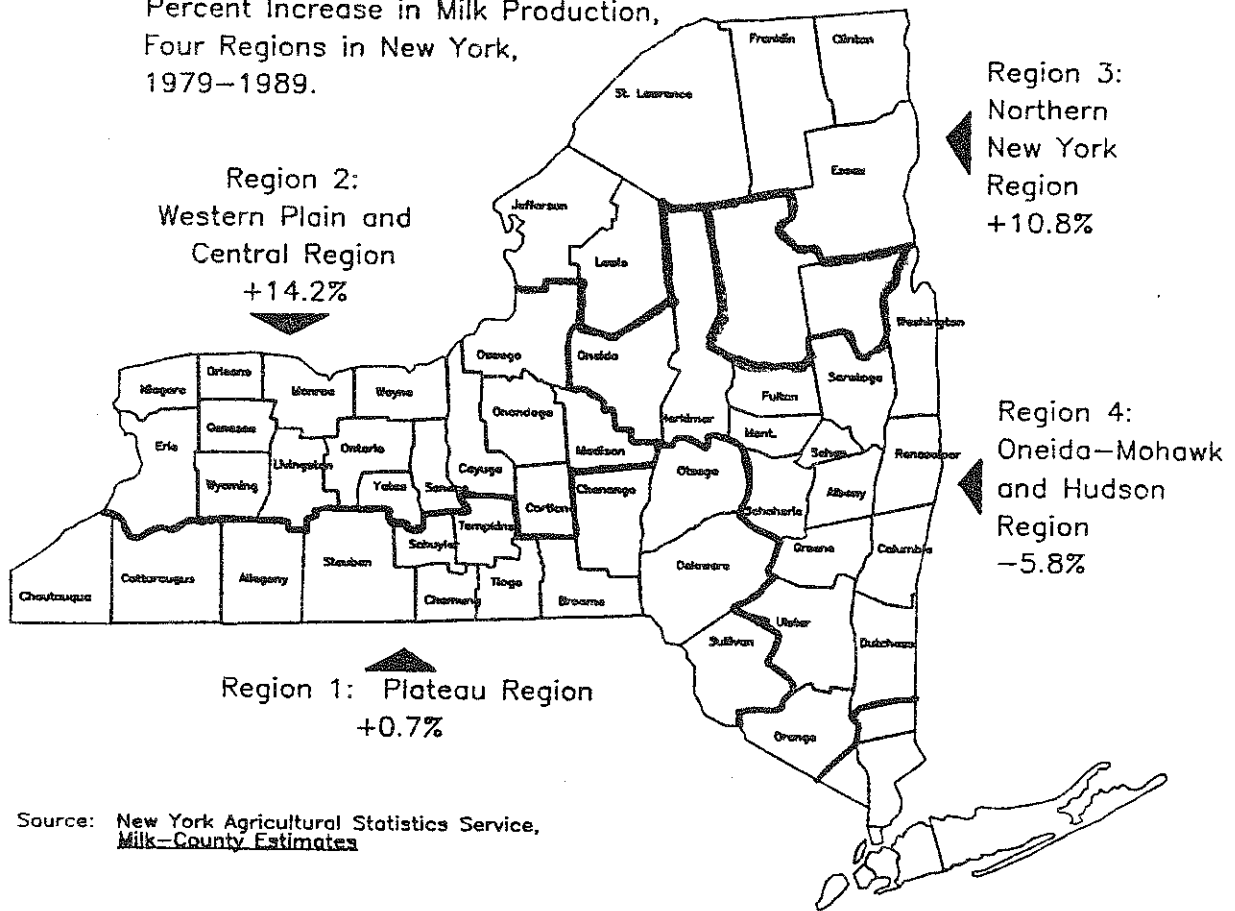

MILK PRODUCTION AND AVERAGE COST OF PRODUCING MILK
FOUR REGIONS OF NEW YORK, 1989

Item	Region*			
	1	2	3	4
<u>MILK PRODUCTION</u> **				
	(million pounds)			
1979	2,981.6	3,104.5	1,929.5	2,590.6
1989	3,003.7	3,546.1	2,138.0	2,441.6
Percent change	+0.7%	+14.2%	+10.8%	-5.8%
<u>COST OF PRODUCING MILK</u>				
	(\$ per hundredweight milk)			
Operating cost	\$10.29	\$10.18	\$ 9.87	\$11.26
Total cost	15.15	14.02	14.62	16.32
Average price received	14.46	14.40	14.26	15.00
Return per cwt. to operator labor, mgmt., & capital	2.62	2.90	2.80	2.28

*See the map above for region descriptions.

**Source: New York Agricultural Statistics Service, Milk-County Estimates.

DAIRY

TEN YEAR COMPARISON: SELECTED BUSINESS FACTORS
New York Dairy Farms, 1980 to 1989

Item	1980	1981	1982	1983	1984	1985	1986	1987	1988	1989
Number of farms	600	553	572	510	458	404	414	426	406	409
<u>Cropping Program</u>										
Total tillable acres	246	257	262	272	280	280	288	305	302	316
Tillable acres rented	76	83	83	91	94	93	100	105	104	117
Hay crop acres	131	131	135	139	143	142	147	153	156	164
Corn silage acres	60	59	70	72	76	69	67	67	74	81
Hay crop, tons DM/acre	2.5	2.5	2.6	2.5	2.7	2.7	2.7	2.7	2.6	2.6
Corn silage, tons/acre	14.5	14.9	14.0	13.5	14.0	14.3	14.3	16.2	14.1	13.4
Fert. & lime exp./tillable acre	\$29	\$32	\$33	\$31	\$32	\$32	\$26	\$27	\$29	\$29
Machinery cost/cow	\$425	\$465	\$432	\$413	\$433	\$426	\$400	\$413	\$398	\$425
<u>Dairy Analysis</u>										
Number of cows	75	79	82	88	89	89	95	101	102	104
Number of heifers	56	59	67	72	76	73	77	79	82	83
Milk sold, cwt.	10,761	11,420	12,105	13,432	13,735	14,001	15,374	16,498	17,200	17,975
Milk sold/cow, lbs.	14,300	14,456	14,762	15,264	15,433	15,679	16,237	16,351	16,882	17,259
Purchased dairy feed/cwt. milk	\$3.47	\$3.51	\$3.27	\$3.44	\$3.28	\$3.04	\$3.10	\$3.21	\$3.71	\$3.99
Purc. grain & conc. as % milk receipts	27%	26%	24%	25%	24%	23%	24%	24%	28%	27%
Purc. feed & crop exp./cwt. milk	\$4.49	\$4.67	\$4.53	\$4.62	\$4.53	\$4.13	\$4.00	\$4.11	\$4.62	\$4.92
<u>Capital Efficiency</u>										
Farm capital/cow	\$5,539	\$5,676	\$5,517	\$5,421	\$5,520	\$5,801	\$5,792	\$5,894	\$6,133	\$6,407
Real estate/cow	\$2,602	\$2,693	\$2,664	\$2,668	\$2,731	\$2,726	\$2,758	\$2,805	\$2,902	\$2,977
Mach. invest./cow	\$1,015	\$1,078	\$1,047	\$1,038	\$1,057	\$1,083	\$1,062	\$1,057	\$1,083	\$1,154
Capital turnover, yrs.	2.2	2.4	2.5	2.4	2.3	2.5	2.3	2.2	2.2	2.1
<u>Labor Efficiency</u>										
Worker equivalent	2.70	2.75	2.83	3.00	3.08	3.17	3.17	3.19	3.17	3.30
Operator/manager eq.	1.30	1.25	1.30	1.32	1.31	1.34	1.33	1.32	1.35	1.39
Milk sold/worker, lbs.	403,000	415,273	427,739	447,733	445,942	442,125	497,555	516,728	542,708	544,598
Cows/worker	28	29	29	29	29	28	31	32	32	32
Labor cost/cow	\$326	\$335	\$352	\$344	\$366	\$387	\$385	\$400	\$426	\$469
<u>Profitability & Financial Analysis</u>										
Labor & mgmt. income/oper.	\$1,565	\$-4,261	\$3,451	\$5,514	\$2,262	\$2,850	\$3,837	\$11,042	\$11,911	\$18,004
Farm net worth	\$288,022	\$301,975	\$306,589	\$322,001	\$336,210	\$325,664	\$348,909	\$398,209	\$426,123	\$468,848
Percent equity	66%	64%	63%	63%	64%	63%	62%	65%	66%	68%

TEN YEAR COMPARISON: AVERAGE COST OF PRODUCING MILK PER HUNDREDWEIGHT
New York Dairy Farms, 1980 to 1989

DAIRY

Item	1980	1981	1982	1983	1984	1985*	1986*	1987*	1988*	1989*
<u>Cash Operating Expenses</u>										
Hired labor	\$ 1.09	\$ 1.20	\$ 1.29	\$ 1.25	\$ 1.39	\$ 1.38	\$ 1.38	\$ 1.49	\$ 1.46	\$ 1.62
Purchased feed	3.60	3.62	3.40	3.59	3.46	3.09	3.15	3.26	3.73	4.02
Machinery repairs & rent	.75	.81	.81	.77	.80	.78	.75	.88	.83	.92
Auto expenses (farm share)	.04	.04	.04	.04	.03	.03	.04	.04	.04	.04
Fuel, oil & grease	.54	.62	.59	.49	.50	.48	.34	.35	.34	.33
Replacement livestock	.29	.23	.19	.16	.10	.10	.13	.13	.11	.17
Breeding fees	.16	.18	.19	.19	.20	.20	.19	.19	.18	.18
Veterinary & medicine	.24	.28	.29	.28	.29	.27	.28	.28	.28	.30
Milk marketing	.35	.40	.50	.93	1.03	.80	.84	.74	.52	.49
Other dairy expenses	.47	.49	.52	.54	.55	.53	.52	.53	.56	.60
Lime & fertilizer	.66	.72	.71	.63	.66	.63	.49	.50	.51	.50
Seeds & plants	.20	.23	.23	.21	.22	.23	.21	.21	.21	.22
Spray & other crop expense	.16	.21	.18	.19	.20	.22	.20	.19	.19	.21
Land, building, fence repair	.21	.22	.21	.18	.18	.17	.16	.20	.22	.27
Taxes	.31	.35	.34	.34	.33	.34	.33	.35	.35	.36
Insurance	.24	.23	.23	.21	.20	.22	.22	.22	.23	.23
Telephone & elec. (farm share)	.28	.32	.35	.36	.36	.37	.39	.38	.38	.39
Interest paid	1.17	1.43	1.54	1.40	1.40	1.25	1.18	1.04	1.02	1.06
Misc. (including rent)	.37	.41	.43	.44	.44	.40	.41	.45	.41	.43
Total Operating Expenses	\$11.13	\$11.99	\$12.04	\$12.20	\$12.34	\$11.50	\$11.22	\$11.43	\$11.57	\$12.34
Less: Nonmilk cash receipts	1.67	1.58	1.47	1.49	1.74	1.58	1.52	1.84	1.86	1.75
Increase in feed & supplies**	.43	.11	.03	.26	.18	.05	.01	.16	.16	.02
Increase in livestock	.39	.25	.35	.24	.16	.18	.12	.10	.08	.12
OPERATING COST OF MILK PRODUCTION	\$ 8.64	\$10.05	\$10.19	\$10.21	\$10.26	\$ 9.69	\$ 9.57	\$ 9.33	\$ 9.47	\$10.45
<u>Overhead Expenses</u>										
Depreciation: mach. & bldgs.	\$ 1.43	\$ 1.56	\$ 1.60	\$ 1.56	\$ 1.65	\$ 1.64	\$ 1.54	\$ 1.43	\$ 1.31	\$ 1.31
Unpaid labor	.14	.14	.14	.12	.12	.12	.13	.10	.11	.12
Operator(s) labor***	1.05	.99	.93	.89	.87	.97	.86	.87	.95	.98
Operator(s) mgmt. (5% of cash rec.)	.72	.76	.75	.76	.76	.72	.71	.74	.74	.81
Interest on farm eq. cap. (5%)	1.34	1.32	1.27	1.20	1.22	1.16	1.10	1.15	1.19	1.24
Total Overhead Expenses	\$ 4.68	\$ 4.77	\$ 4.69	\$ 4.53	\$ 4.62	\$ 4.61	\$ 4.34	\$ 4.28	\$ 4.30	\$ 4.46
TOTAL COST OF MILK PRODUCTION	\$13.32	\$14.82	\$14.88	\$14.74	\$14.88	\$14.30	\$13.91	\$13.61	\$13.77	\$14.91
AVERAGE FARM PRICE OF MILK	\$12.81	\$13.66	\$13.56	\$13.64	\$13.49	\$12.90	\$12.65	\$12.89	\$13.03	\$14.53
Return per cwt. to operator labor, capital, & management	\$2.60	\$1.91	\$1.63	\$1.75	\$1.46	\$1.45	\$1.41	\$2.04	\$2.14	\$2.65
Rate of return on farm eq. cap.	3.1%	0.6%	-0.2%	0.4%	-0.7%	-1.0%	-0.7%	1.9%	1.8%	3.5%

*Accrual receipts and expenses. **Increase in grown feeds, 1985-1989. ***1979 = \$650/month, 1980-1984 = \$750/month, 1985 = \$800/month, 1986 = \$900/month, 1987 = \$900/month, 1988 = \$1,000/month, 1989 = \$1,050/month of operator labor.

NEW YORK MILK COW OPERATIONS BY HERD SIZE
1978 AND 1987

Herd Size	1978		1987	
	No. of Farms	No. Cows as % of NY Total	No. of Farms	No. Cows as % of NY Total
<50 cows	12,693	35%	6,846	22%
50 - 99	5,613	42	5,178	42
100 - 500	1,360	22	1,787	33
≥500	<u>8</u>	<u>1</u>	<u>29</u>	<u>2</u>
Total	19,674	100%	13,840	100%

SOURCE: U.S. Department of Commerce, Bureau of the Census, 1978/1987 Census of Agriculture.

The number of farms with milk cows totaled 13,840 in New York in 1987, a 30 percent decrease since 1978. The number of farms with fewer than 50 cows decreased by 46 percent, down to 6,846 farms. The number of farms with 50 to 99 cows remained relatively stable in total and as a percent of the total number of milk cows. The number of farms with 100 to 500 cows increased by 427 and as a percent of the total number of milk cows to 33 percent. There were eight farms with 500 or more cows in 1978 and 29 farms in 1987. The number of large farms (500 or more cows) accounted for only two percent of the State total of milk cows in 1987.

CASH RETURN AND GOVERNMENT PAYMENTS,
SELECTED FARM TYPES, 1987

Farm Type	Net Cash Return Per Farm From Agricultural Sales	Percent of Farms With :		Government Payments
		Gain	Loss	
All Farms	\$13,690	55	45	\$1,773
Horticultural	34,986	75	25	91
Dairy	32,039	91	9	2,075
Vegetable	18,614	67	33	2,607
Fruit	9,693	52	48	326
Potatoes & Field Crops ¹	2,363	43	57	808
Cash Grains	395	36	64	9,877
Livestock	-517	28	72	738

¹Excludes cash grains.

SOURCE: U.S. Department of Commerce, Bureau of the Census, 1987 Census of Agriculture.

Net cash return per farm from agricultural sales for dairy farms was second only to horticultural farms in 1987. However, dairy farms had the highest percent of any farm type category reporting gains. Ninety-one percent reported gains and only nine percent a loss (negative net cash return). Government payments were, as expected, highest on cash grain farms. Dairy farms averaged over \$2,000 in government payments in 1987.

Other Agricultural Economics Extension Publications

No. 90-20	Improving Communication About Risks Associated With Residues of Agricultural Chemicals on Produce	Nancy Ostiguy Enrique E. Figueroa Carole Bisogni
No. 90-21	Cornell Cooperative Extension Farm Business Management Program Guidelines Suggestions, and Resources	Stuart F. Smith Wayne A. Knoblauch Gerald B. White
No. 90-22	Fruit Farm Business Summary, Lake Ontario Region, New York, 1989	Darwin P. Snyder Alison M. DeMarree
No. 90-23	Poultry Farm Business Summary, New York 1989	Darwin P. Snyder Stewart Ackerman Kristen Park
No. 90-24	1989 New York Beef Cow-Calf Farm Business Summary	C. N. Rasmussen Stuart F. Smith Danny G. Fox
No. 90-25	Employee Recruitment and Selection Teaching Manual	Thomas Maloney Joann Gruttadaurio Walter Nelson Kristen Park Joan Petzen Alan White
No. 90-26	Employee Recruitment and Selection Participant Manual	Thomas Maloney Joann Gruttadaurio Walter Nelson Kristen Park Joan Petzen Alan White
No. 90-27	Farm Income Tax Management and Reporting	George L. Casler Stuart F. Smith
No. 90-28	Pro-Dairy Financial Data Collection Workbook	Jonas B. Kauffman Stuart F. Smith
No. 90-29	Changes in the New York State Farm Minimum Wage Law	Thomas R. Maloney Kay Embrey