



AgEcon SEARCH
RESEARCH IN AGRICULTURAL & APPLIED ECONOMICS

The World's Largest Open Access Agricultural & Applied Economics Digital Library

This document is discoverable and free to researchers across the globe due to the work of AgEcon Search.

Help ensure our sustainability.

Give to AgEcon Search

AgEcon Search

<http://ageconsearch.umn.edu>

aesearch@umn.edu

*Papers downloaded from **AgEcon Search** may be used for non-commercial purposes and personal study only. No other use, including posting to another Internet site, is permitted without permission from the copyright owner (not AgEcon Search), or as allowed under the provisions of Fair Use, U.S. Copyright Act, Title 17 U.S.C.*

No endorsement of AgEcon Search or its fundraising activities by the author(s) of the following work or their employer(s) is intended or implied.

June 1990

A.E. Res. 90-6

Determination of Butter/Powder Plant Manufacturing Costs Utilizing an Economic Engineering Approach

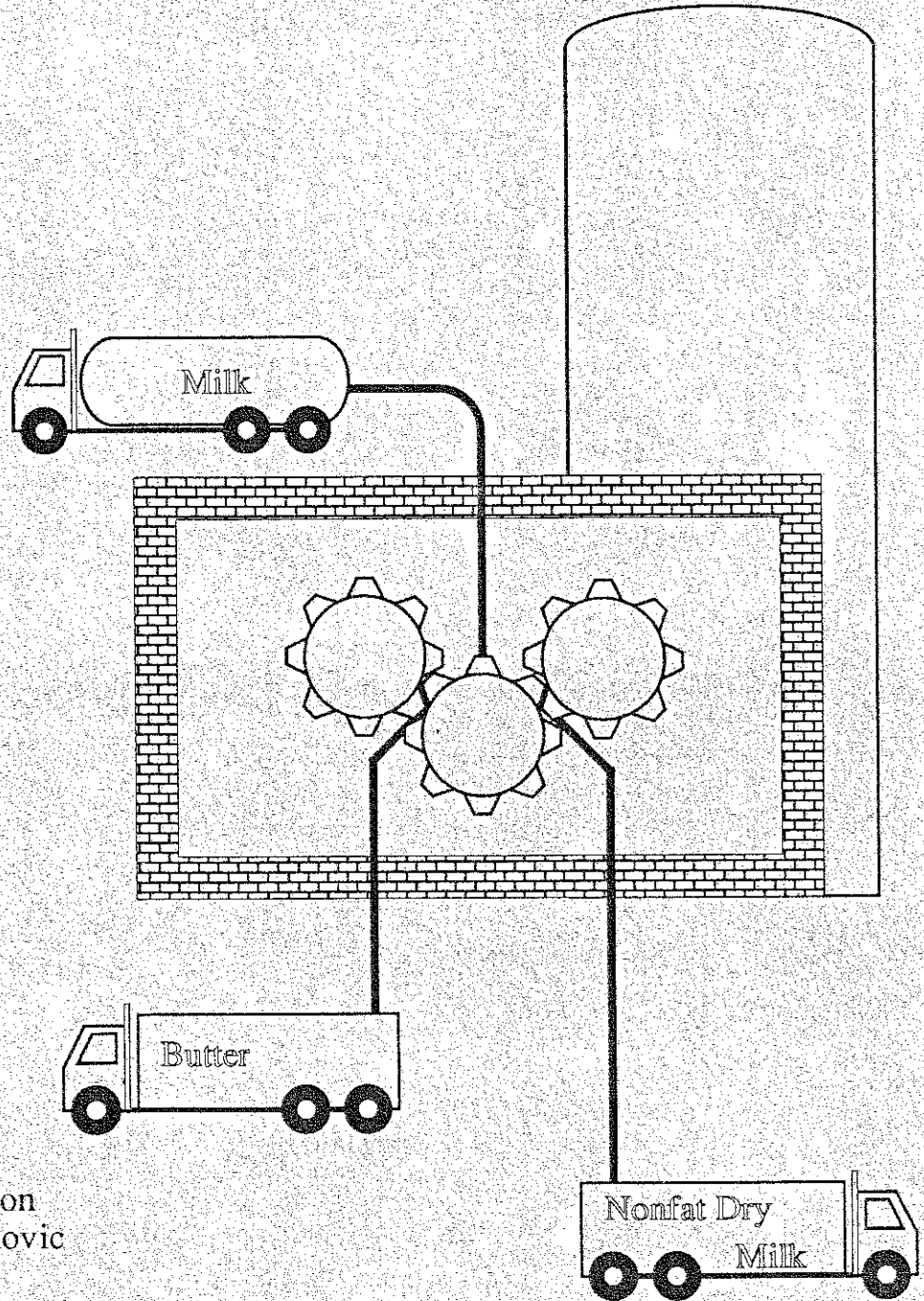

by
Mark W. Stephenson
Andrew M. Novakovic

Department of Agricultural Economics
Cornell University Agricultural Experiment Station
New York State College of Agriculture and Life Sciences
A Statutory College of the State University
Cornell University, Ithaca, New York 14853

It is the policy of Cornell University actively to support equality of educational and employment opportunity. No person shall be denied admission to any educational program or activity or be denied employment on the basis of any legally prohibited discrimination involving, but not limited to, such factors as race, color, creed, religion, national or ethnic origin, sex, age or handicap. The University is committed to the maintenance of affirmative action programs which will assure the continuation of such equality of opportunity.

Preface

Mark W. Stephenson is a Doctoral Candidate and Andrew M. Novakovic is an Associate Professor in the Department of Agricultural Economics at Cornell University.

Grateful acknowledgement is given to the following organizations:

Argi•Mark, Inc.
GEA—Wiegand Evaporator Division
Land O' Lakes, Inc.
Len E. Ivarson, Inc.
Niro Atomizer
O-AT-KA Milk Products Cooperative, Inc.
Paul Mueller Company
Roy's Dairy

Although recognition of an organization does not imply endorsement of a product line, their participation in this study provided a good deal of the technical information used by the engineering firm of Mead & Hunt in plant designs. Funding for this project is provided in part by the Division of Dairy Industry Services, New York State Department of Agriculture and Markets.

Additional copies of this publication or the related publication entitled **Manufacturing Costs In Ten Butter/Powder Processing Plants** can be requested from:

Andrew Novakovic
Department of Agricultural Economics
Cornell University
Warren Hall
Ithaca, NY 14853-7801

TABLE OF CONTENTS
AND
LIST OF TABLES AND FIGURES

REPORT SUMMARY	iv
THE PROCESS OF MANUFACTURING BUTTER AND NONFAT DRY MILK.....	1
OBJECTIVES OF THE SURVEY.....	2
THE ECONOMIC ENGINEERING APPROACH.....	3
MODELS AND PLANT SIZES	4
Base or "Core" Plants.....	4
Retail Butter Packaging.....	6
Blends and Condensed Skim Milk Sales.....	6
Raw Milk and Cream Receipts.....	6
Operating Schedules.....	6
Seasonality of Plants	7
Table 1—Matrix of Plant Models	8
PRODUCT ASSUMPTIONS, THEORETICAL YIELDS AND PLANT VOLUMES	9
Table 2—Assumed Composition of Products.....	9
Figure 1—Theoretical Yields from cwt of Raw Milk.....	10
Table 3—Daily Volumes Through Plants at 100% Capacity.....	11
PLANT CENTERS AND LAYOUT.....	11
Figure 2—Simplified Product Flow Through a Butter/Powder Plant.....	12
Table 4—Plant Centers	13
DATA GENERATION	14
Table 5—Data Categories	14
PARAMETERS USED	16
Cost of Capital.....	16
Utility Rates	16
Labor	17
Table 6—Distribution of Wages.....	17
ESTIMATION OF COSTS	18

RESULTS.....	19
Initial Capital Investments.....	19
Table 7—Capital Investments.....	20
Cost Comparison.....	20
Table 8—Percentage of Total Costs in Simulated vs. Actual Plants.....	21
Short and Long-Run Average Cost Curves.....	22
Table 9—Estimated Fixed, and Variable Costs per Pound in the Base Plants.....	22
Figure 3—Short-Run Average Cost Curves for Butter Processing.....	23
Figure 4—Short-Run Average Cost Curves for Butter Printing Plants.....	24
Table 10—Estimated Coefficients Used in Determining Average Costs of Daily Butter.....	25
Figure 5—Long-Run Average Cost Curves for Butter Processing.....	26
Figure 6—Short-Run Average Cost Curves for Powder Processing.....	27
Table 11—Estimated Coefficients Used in Determining Average Costs of Daily Powder.....	27
Figure 7—Long-Run Average Cost Curves for Powder Processing.....	28
Figure 8—Long-Run Average Cost Curves for Processing cwt Milk.....	29
Table 12—Estimated Coefficients Used in Determining Average Costs of Daily cwt Milk.....	30
Processing Environments Reflecting More and Less Cream Receipts.....	30
Marketing Alternatives.....	31
The Effects of Scale, Scheduling and Seasonality on Processing Cost.....	33
Table 13—Effects of Scale and Scheduling on Processing Cost.....	34
Figure 9—Isoquants and Costs of Processing Over Different Plant Sizes and Schedules.....	35
Table 14—Weekly Cost of Processing With Seasonally Different Volumes.....	36
Affects of the Business Climate on Manufacturing Costs.....	37
Table 15—Sensitivity in Processing Costs to Parameter Changes.....	38
Evaluation of the Economic Engineering Approach.....	39
APPENDIX A—Calculations of Annual Equivalent Costs and Cost per Pound.....	41
Annual Equivalent Costs.....	41
Costs per Pound of Product and cwt of Raw Milk.....	42
APPENDIX B—Regression Estimates of the Simulated Plants.....	43
Table 16—Breakdown of Daily Throughput in Plants Operating at 100% Capacity.....	44
Table 17—Regression Estimates of Daily Fixed and Variable Costs.....	45
Table 18—Regression Estimates of the Short-Run Average Costs of Butter Production.....	46
Table 19—Regression Estimates of the Short-Run Average Costs of NDM Production.....	47
Table 20—Regression Estimates of the Short-Run Average Costs of Processing cwt Milk.....	48
Table 21—Regression Estimates of Daily Total Costs with Several Factors of Production.....	49

Report Summary

Among the objectives of Cornell's Program on Dairy Markets and Policy is a series of projects to determine the costs of processing hard, or storable, dairy products.¹ This report represents the second of a two part effort to determine the cost of processing butter and nonfat dry milk. The first study summarizes the results of a survey of existing plants. This report, on the second phase of the project, attempts to explore fundamental relationships between costs and factors of production using an economic engineering approach. Short and long-run average cost curves are calculated for butter and nonfat dry milk manufacture as well as per cwt of raw milk processed. From these average cost curves, the effects of plant size, weekly scheduling and seasonal variation in production are examined. Also considered are changes in processing costs when alternative marketing opportunities such as retail butter packaging and bulk sales of blends and condensed products are manufactured. Finally, the sensitivity of processing costs to changes in the business environment are investigated.

At the average level of throughput in the survey plants, processing costs per cwt of milk are nearly identical in both the actual and simulated plants. At levels under and over the average, costs differ in a way indicative of higher fixed and lower variable costs in the real plants. Plant size at any given volume (the smallest plant), and plant throughput at any given size (maximum plant capacity) are shown to be cost reducing when viewed separately. Viewed in combination, these scale and scheduling "rules of thumb" are not obvious. That is, at any given volume, the smallest plant, processing nearest full capacity, for the greatest number of days per week, is not necessarily the low cost processor. This implies that over capacitization, if properly managed, may be a rational decision.

¹ Three reports on cheese manufacturing and one on butter/powder manufacture are presently available from the Publications Office of the Department of Agricultural Economics, Cornell University: Jens K. Mesa-Dishington, Richard D. Aplin, and David M. Barbano, Economic Performance of 11 Cheddar Cheese Manufacturing Plants in Northeast and North Central Regions, Department of Ag Economics, Cornell University, A.E. Res. 87-2; Jens K. Mesa-Dishington, Richard D. Aplin, and David M. Barbano, Cheddar Cheese Manufacturing Costs Economies of Size and Effects of Different Current Technologies, Department of Ag Economics, Cornell University, A.E. Res. 87-3; John C. Martin, David M. Barbano, and Richard D. Aplin, Diversification of the Cheddar Cheese Industry Through Specialty Cheese Production: An Economic Assessment, Department of Ag Economics, Cornell University, A.E. Res. 89-9; Stephenson, M. W. and A. M. Novakovic, Manufacturing Costs in Ten Butter/Powder Processing Plants, Department of Agricultural Economics, Cornell University, A.E. Res. 89-19, September 1989.

Other myths are debunked regarding the magnitude of potential savings in processing costs. Plants that operate in a very seasonal environment experience manufacturing costs that are inflated less than 1% over non seasonal plants. Product yields that are improved by cutting butterfat and solids-not-fat losses in half only provide a 3% reduction in processing cost per pound. And, the potential for savings by marketing wet products (bulk blends and condensed skim milk) may not be realized. Savings of 1% to 3% are not trivial in any business, but they are surely much smaller than one would guess from the level of discussions on these subjects.

Unequivocally, savings [added expenses] are realized with the reduction [increase] in factors affecting the business environment. Of the factors investigated, a change in the average wage causes the largest change in processing costs followed by the cost of capital (interest rate). The ratio of sensitivity to changes in price of capital to labor increases from 0.34 to 0.66 as plants increase in size. This indicates, in a classical sense, that the larger plants are substituting capital for labor.

An evaluation of the two research approaches, economic engineering vs. statistical analysis of accounting data, is indecisive. If the requirement of a study is to replicate existing plants then the survey approach is inexpensive, straightforward and non-controversial. On the other hand, if questions of optimality are paramount, then the economic engineering approach is likely to be without rival.

The Process of Manufacturing Butter and Nonfat Dry Milk

The principles underlying the manufacture of butter and dry milk have changed little over the course of history. In the 13th century, Marco Polo recorded the Mongolians separating milk into cream and skim fractions. The butterfat was churned into butter and the skim portion was dried in the sun to a paste-like consistency. These processed dairy products offered the same advantages to an earlier nomadic people as they do to an industrialized civilization today—dairy surpluses can be transformed into products that are as nutritious, more transportable, and have greater keeping qualities than whole milk.

In the United States, butter making was a very common farm practice through the mid 1800's. After the cream was skimmed, butter was churned by the farm wife and the skim portion fed to the livestock. Twice a year a butter buyer from one of the large cities would stop at the farm to purchase the butter that was in great demand in the nation's population centers. The first creamery, or centralized factory, for manufacturing butter was established in 1856 in Orange County, New York.² This was a plant that produced the joint products of butter from the cream and part-skim cheese from the remaining milk. At that time, the part-skim cheese was not held in high regard by consumers.

Farm butter continued to dominate well into the 1920's. The obtaining of cream from the milk was perhaps the most formidable deterrent to the factory system. Gravity separation was the only means of collecting cream until 1890 at St. Albans, Vermont, the Franklin County Creamery Company installed a mechanical separator. Farmers could now haul their whole milk supplies into the creamery where it would be separated and take home the unwanted skim portion to be fed to livestock or dumped. Although the efficiency gains from mechanical separators and churns were advantageous, milk producers were becoming increasingly dissatisfied with the cost of transporting large volumes of whole milk to, and skim milk from the creameries. It was not until the end of the 1800's and the introduction of the DeLaval hand-operated farm separator and advances in churns and butter workers that the factory approach to butter manufacture became predominant. Evolution of the butter making process did not advance greatly until the continuous churn was invented in 1965 and the ability to print soft butter followed in 1966.

² Selitzer, Ralph, The Dairy Industry In America Published by Dairy and Ice Cream Field, and Books for Industry Divisions of Magazines for Industry, Inc., 777 Third Avenue, New York, NY.

An 1899 editorial in Hoard's Dairyman declared that "what to do with the skim milk is about the biggest unsolved question before the dairymen at the present time." As early as 1856, Gail Borden perfected the vacuum concentration of milk. During the Civil War, Union troops were sustained by the supply of evaporated milk from Borden's factories. In 1902, the Just-Hatmaker process of roller drying milk was developed and as early as 1907, the first successful spray drying plant which incorporated a precondensing pan was opened in New York. This set the stage for the first real demand for skim milk. The non-fat dried product gained steady acceptance as an ingredient in baked goods and confectionery items and with the outbreak of World War II, it was widely sought as there was a starving Europe to be fed.

Today, the manufacture of butter and nonfat dry milk is typically a joint but separate process. Joint because butter and nonfat dry milk are the residual claimants of the cream and skim fractions of the milk supply. And, separate because the process of manufacturing butter still requires a 12-24 hour lag in production while the cream ages and nonfat dry milk production does not need such a lag. Modern butter/powder plants take in whole milk, cream and other products and produce butter, nonfat dry milk and other products. They are characterized by continuous churns and soft butter printers, vacuum preconcentration in efficient, modern evaporators, and spray drying.

Objectives of the Study

The objectives of this study are:

- A. Determine the achievable short-run and long-run average costs of production for butter and non-fat dry milk in modern, well managed plants, consistent with observed industry performance.
- B. Determine the effects of "scale" on the cost of producing butter and non-fat dry milk.
- C. Determine the cross effects of "scale" with alternative operating schedules on the cost of producing butter and non-fat dry milk.

- D. Determine the effects of alternative daily and seasonal utilization on the cost of producing butter and non-fat dry milk.
- E. Determine the costs of production for marketing opportunities represented by retail butter packaging and bulk sales of blends and unsweetened condensed skim milk.
- F. Determine the effects of alternative proportions of raw milk versus cream receipts.
- G. Determine the sensitivity of processing costs to changes in the business environment.
- G. Determine the effects of yield on the cost of producing butter and non-fat dry milk.

The Economic Engineering Approach

In this study the economic engineering, or synthetic approach, is applied for the purpose of determining the costs of production. The other alternative would have been the use of statistical estimation of accounting data. The accounting approach was not favored because of the difficulty in obtaining enough detail from existing plants. Still another problem arising from the accounting data is comparability of results between plants. Accounting data include many plant specific idiosyncrasies which tend to mask the functional cost relationships of the basic processes. Because of these problems, economic engineering estimation was selected as the superior alternative for this study.

The synthetic method has been in use for many years. The first published work using this method was a study of milk plants in New England in 1942.³ Since that time it has been used in many other pieces of research. The economic engineering approach is not without valid criticism. Often, the approach is employed because there is no means of obtaining accounting data. The results of such a study cannot be compared with other sources, and the danger of overlooking important costs or oversimplifying technical relationships and thus underestimating total costs is very real. To ameliorate much of this criticism, a two step approach has been used.

A statistical analysis of accounting data from ten butter/powder plants across the country was first conducted to establish benchmarks of performance.⁴ From this earlier piece of work, dominant processing practices, technologies, input and output mixes, and costs of the major factors of production were determined for the contemporary processing environment. As a further measure of precaution, the parameters for the engineering study have been closely guided by an advisory panel of dairy industry personnel. Finally, the actual plant design and operational requirements were drafted by consulting engineers.

Models and Plant Sizes

Base or "Core" Plants

To accomplish the objectives, plants to be modeled are efficient plants representative of characteristics observed in the field. They typically have an evaporative capacity equivalent to the wetting requirements of the dryer. It is assumed that the only products to be dried will be buttermilk powder and NDM and therefore, a less expensive box-type dryer would be adequate. However, the added flexibility to produce higher fat dried products is desirable in modern plants and as such, a two stage cyclone dryer is

³ Bressler, R. G. Jr., Economies of Scale in the Operation of Country Milk Plants, New England Research Council with the New England Agricultural Experiment Stations and the U. S. Department of Agriculture, 1942.

⁴ Stephenson, M. W. and A. M. Novakovic, Manufacturing Costs in Ten Butter/Powder Processing Plants, Department of Agricultural Economics, Cornell University, A.E. Res. 89-19, September 1989.

specified. Plants typically process surplus cream as butter, given current industry practices, it is assumed that the capacity of the churn should be twice the milk equivalent of the evaporator/dryer.⁵ All of the plants are engineered such that the entire amount of the butter churned could be printed in 68 pound commercial boxes. Five butter/powder plants of varying capacities are modeled as the base plants. These plants are used to examine the basic economies of scale in butter/powder manufacturing. In addition, marginal changes in base models will be used to study the effect of non-scale variables. Assuming a 20 hour run with 4 hours of cleanup, these plants have the following average daily capacity to process:

<u>Plant #</u>	<u>Pounds Raw Milk</u>	<u>Pounds Cream</u>
1	900,000	75,000
2	1,400,000	117,000
3	1,800,000	150,000
4	2,300,000	192,000
5	2,700,000	225,000

There are also two butter-only plants that process purchased cream (40% butterfat). Assuming a 16 hour operating day including 3 hours of cleanup, these plants have the following daily capacity to process on average:

<u>Plant #</u>	<u>Pounds Raw Milk</u>	<u>Pounds Cream</u>
6	0	100,000
7	0	162,000

⁵ The survey which yielded the accounting data revealed that plants have, on average, 2.5 time the milk equivalent capacity to churn cream than they do to process the solids-not-fat. It further revealed that, on average, they actually processed (churned) 1.5 times the milk equivalent in butterfat.

Retail Butter Packaging

Base plants 2 and 4, and the two butter-only plants, 6 and 7 are modified to represent a variety of retail butter packaging options. Retaining the ability to print 100 percent of the churn capacity in 68 lb. commercial boxes, they also have the capability to:

print up to 33% of the butter produced as one pound solids

print up to 33% of the butter produced as 1/4 pound sticks

print up to 6 % of the butter produced as continental wraps

Blends and Condensed Skim Milk Sales

Base plants 2 and 4 are modified to handle up to 20% of the cream available for processing as blends. The churns are down-sized accordingly.

Base plants 2 and 4 are modified to handle up to 50% of the skim milk available as sales of bulk condensed skim milk. The dryers are down-sized accordingly.

Base plants 2 and 4 are modified to market up to 20% of the cream as blends and to process up to 50% of the skim milk as bulk condensed with dryers and churns downsized accordingly.

Raw Milk and Cream Receipts

Base plants 2 and 4 are also modified as raw milk only plants (no outside cream). The churns are down-sized accordingly.

Base plants 2 and 4 are modified to handle up to two times as much outside cream as the base assumptions. The churns and printers are up-scaled accordingly.

Operating Schedules

All types of dairy processing plants are run according to different operating schedules. Butter/powder plants probably represent the most extreme range. In some cases, plants are run virtually every hour of every day. In many other cases, inter-week fluctuations in supply may cause plants to run intermittently at varying levels of capacity. Base plants are simulated to represent several alternatives.

The core plant designs specify an operating schedule of 24 hours per day with 4 hours of cleanup. These plants are envisioned as operating 6 days per week. The base plants will also be simulated to reflect operation from 0 to 24 hours per day and from 3 to 7 days per week. If plants are operational at all, they are not operated for less than an eight hour shift as several hours are required to bring some of the equipment up to a stable operating temperatures.

Seasonality of Plants

The cost effects of variations in seasonal utilization are examined using combinations of the daily and weekly schedules listed above over alternative periods during the year. Plants are categorized on their yearly production pattern as follows:

Non seasonal	{ 24 hours/day—7 days/week—52 weeks/year
Highly seasonal	{ 24 hours/day—7 days/week—15 weeks/year 24 hours/day—5 days/week—22 weeks/year 24 hours/day—3 days/week—15 weeks/year

The ratio of cream to skim milk processing is not constant throughout the year.⁶ Therefore, the schedule above reflects the processing pattern of the milk fraction which dominates plant operation at a given point in time.

Table 1 displays the matrix of plant situations to be engineered and simulated. Model numbers 1–19 constitute plants with fundamentally different engineering parameters while models 20–29 are indicative of simulations of models 1–5. The engineered plants are at 100% capacity when operating 24 hours a day for all plants except model numbers 6 and 7 which attain full capacity with a 16 hour day.

⁶ The survey indicates that butter manufacture is typically more seasonal than SNF processing.

Table 1. Matrix of Plant Models

Model No.	Base Plant No.	Butter Printing	Other Outputs	Other Inputs	Operating Hours/Day	Operating Days/Week
<u>BASE PLANTS</u>						
1	1	68 lb	none	none	24	3 through 7
2	2	68 lb	none	none	24	3 through 7
3	3	68 lb	none	none	24	3 through 7
4	4	68 lb	none	none	24	3 through 7
5	5	68 lb	none	none	24	3 through 7
6	6	68 lb & prints	none	none	16	3 through 7
7	7	68 lb & prints	none	none	16	3 through 7
<u>RETAIL BUTTER PACKAGING</u>						
8	2	68 lb & prints	none	none	24	6
9	4	68 lb & prints	none	none	24	6
<u>BLENDS AND CONDENSED MILK SALES</u>						
10	2	68 lb	Blends	none	24	6
11	4	68 lb	Blends	none	24	6
12	2	68 lb	Cond.	none	24	6
13	4	68 lb	Cond.	none	24	6
14	2	68 lb	Blends & Cond.	none	24	6
15	4	68 lb	Blends & Cond.	none	24	6
<u>CREAM RECEIPTS</u>						
16	2	68 lb	none	No Cream	24	6
17	4	68 lb	none	No Cream	24	6
18	2	68 lb	none	More Cream	24	6
19	4	68 lb	none	More Cream	24	6
<u>OPERATING SCHEDULES</u>						
20	1	68 lb	none	none	20	3 through 7
21	2	68 lb	none	none	20	3 through 7
22	3	68 lb	none	none	20	3 through 7
23	4	68 lb	none	none	20	3 through 7
24	5	68 lb	none	none	20	3 through 7
25	1	68 lb	none	none	16	3 through 7
26	2	68 lb	none	none	16	3 through 7
27	3	68 lb	none	none	16	3 through 7
28	4	68 lb	none	none	16	3 through 7
29	5	68 lb	none	none	16	3 through 7

Product Assumptions, Theoretical Yields And Plant Volumes

It is necessary to make some assumptions regarding the composition of raw milk and the products manufactured from it. Although milk is a complex fluid with many identifiable fractions, there are only three that are important to a butter/powder plant: butterfat, solids-not-fat (hereafter referred to as "SNF") and water. Total solids are equal to butterfat + SNF. Table 2 shows the product assumptions that are used in this study.

Table 2. Assumed Composition of Products

Product	%BF	%SNF	%Moisture
Raw Milk ⁷	3.71%	8.70%	87.60%
Skim Milk	0.20%	9.02%	90.78%
Cream	40.00%	5.37%	54.63%
Butter	80.50%	1.60%	17.90%
Buttermilk	0.60%	9.10%	90.30%
Bulk Condensed Milk	0.78%	35.22%	64.00%
Bulk Blends	22.00%	25.51%	52.49%
NDM	2.10%	94.70%	3.20%
Buttermilk Powder	5.99%	90.81%	3.20%

These product values can be used to determine theoretical yields in butter/powder plants. In practice, the theoretical yields are not achieved and butterfat losses approach 2% while SNF losses are approximately 0.6%. Figure 1 is a diagram of major processing events in a butter/powder plant and the theoretical yields from a hundredweight (cwt) of raw milk along the production path. The diagram illustrates the possible inputs and outputs which are discussed in this report. For any plant or any given point in time, only parts of this process flow may be observed.

⁷ These values are the weighted average component levels for the Upper Midwest in 1985 according to USDA staff paper 86-01 entitled "Upper Midwest Marketing Area—Analysis of Component Levels in Individual Herd Milk at the Farm Level, 1984 and 1985".

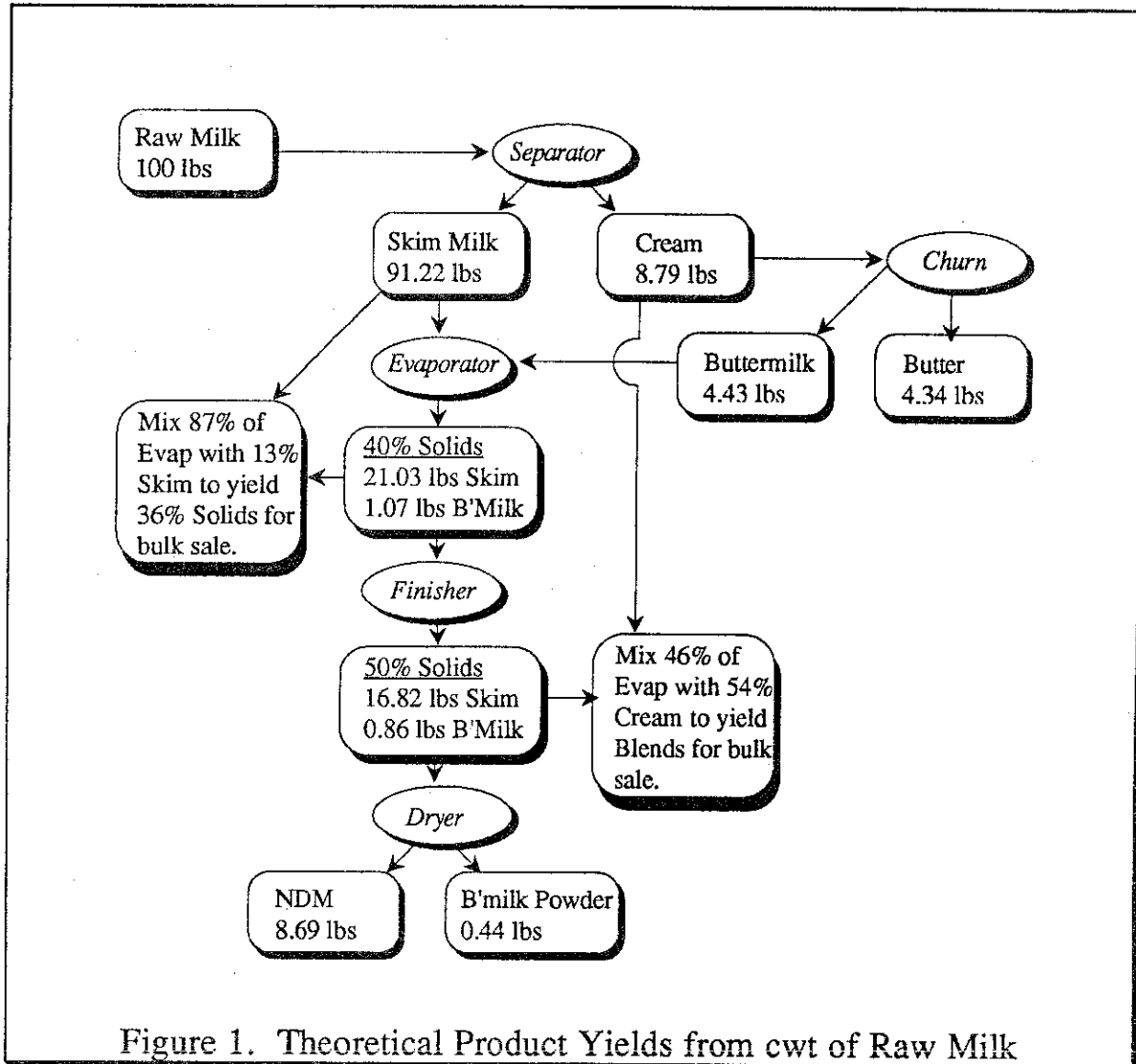

Using these theoretical yields and the model plant input and output mixes from the section entitled "Models and Plant Sizes", a table of plant product volumes can be generated. Table 3 shows the throughput that is used by the engineering firm as the bases to design the model plants.

Table 3. Daily Volumes Through Plants at 100% Capacity

Model No.	Milk Received	Cream Received	lbs/day Bulk Cond	lbs/day Bulk Blends	lbs/day Butter	lbs/day NDM	lbs/day B'milk Powd
1	900,000	75,000	0	0	76,016	78,194	7,776
2	1,400,000	117,000	0	0	118,411	121,635	12,112
3	1,800,000	150,000	0	0	152,031	156,388	15,552
4	2,300,000	192,000	0	0	194,426	199,829	19,888
5	2,700,000	225,000	0	0	228,047	234,582	23,327
6	0	100,000	0	0	49,314	0	0
7	0	162,000	0	0	79,889	0	0
8	1,400,000	117,000	0	0	118,411	121,635	12,112
9	2,300,000	192,000	0	0	194,426	199,829	19,888
10	1,400,000	117,000	0	89,352	94,729	100,289	9,690
11	2,300,000	192,000	0	146,713	155,541	164,780	15,911
12	1,400,000	117,000	163,532	0	118,411	60,818	12,112
13	2,300,000	192,000	268,659	0	194,426	99,915	19,888
14	1,400,000	117,000	163,532	89,352	94,729	39,472	9,690
15	2,300,000	192,000	268,659	146,713	155,541	64,866	15,911
16	1,400,000	0	0	0	60,713	121,635	6,210
17	2,300,000	0	0	0	99,743	199,829	10,203
18	1,400,000	234,000	0	0	176,108	121,635	18,014
19	2,300,000	384,000	0	0	289,110	199,829	29,574

Plant Centers and Layout

Economic engineering studies have often been referred to as having employed the "building block approach"—a description well applied to this type of work. To simulate butter/powder plants, a logical breakdown into plant centers is first made. The assignment of plant centers is based upon a working knowledge of the manufacturing processes and product flows through a plant. Figure 2, is a simplified diagrammatic representation of the product flow in a butter/powder plant.

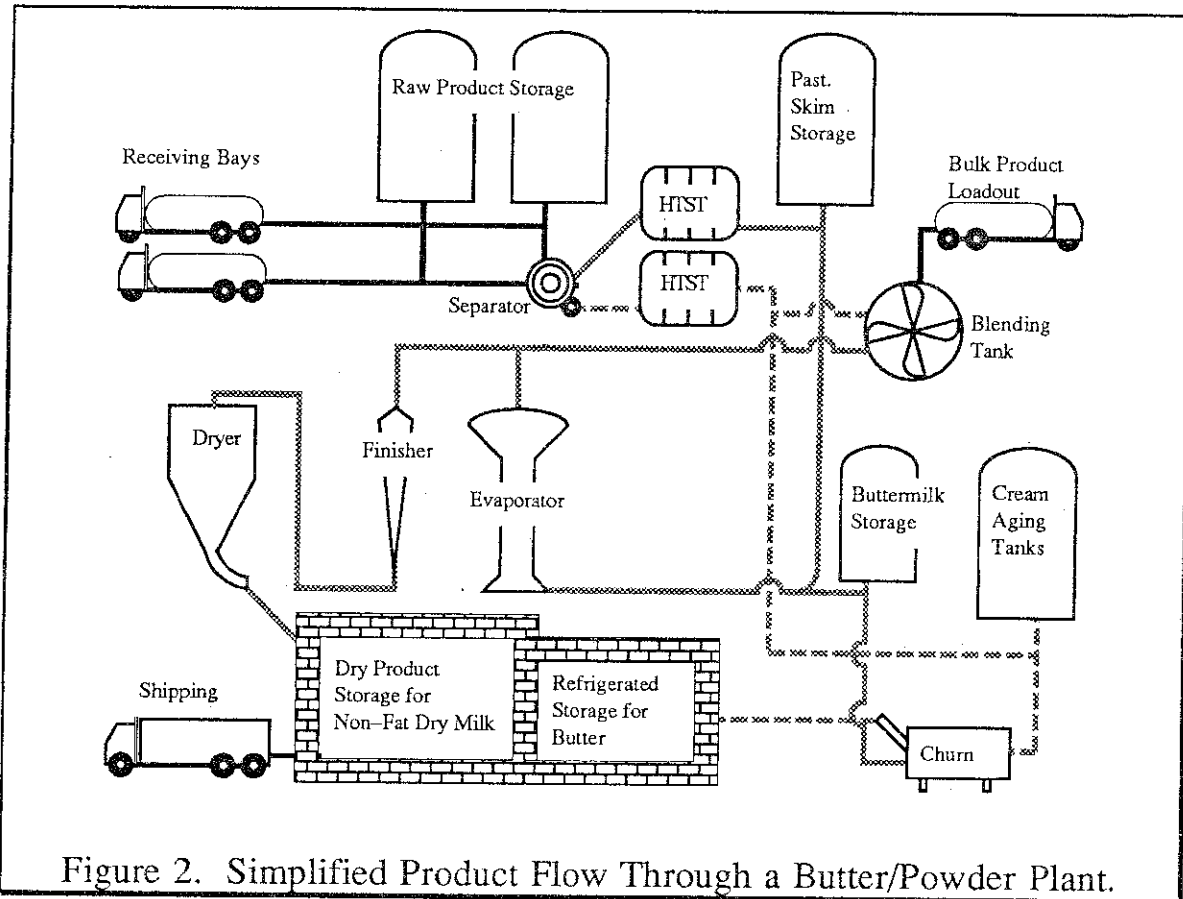

Figure 2. Simplified Product Flow Through a Butter/Powder Plant.

A rule-of-thumb that is used to determine plant centers is that it begins with storage and ends with a pipeline just prior to storage in the next center. For instance, The receiving bays are determined to be a plant center beginning with a tanker truck and ending with the pipeline just prior to the raw product silos.

These plant centers are engineered to accommodate the equipment and manpower needed to carry out specific tasks within the plant. Again, using the receiving bays as an example, the task to be accomplished is that of off-loading cream and raw milk, determining the volume and printing weight slips of product off-loaded, deaerating the product, and washing the trucks. To execute this task, there needs to be a building structure and equipment such as stainless steel piping, pumps, truck washers, trolleys, etc. Each of these items then become one of the building blocks used in the simulation. To each of these building blocks there is assigned an initial purchase price or construction cost, fixed and variable maintenance costs, repairs, utilities, labor, cleaning supplies, packaging and miscellaneous items. It is the sum of all values assigned to these blocks that provides the total cost of operating each center. Table 4 describes each of the plant centers identified in this economic engineering study.

Table 4. Plant Centers

Center	Description
Receiving	Raw products are off-loaded from tanker trucks.
CIP (Raw Side)	Clean-In-Place for the equipment used prior to pasteurizing.
Waiting	Waiting lounge for truck drivers.
Bulk Chemical	Storage center for bulk cleaning chemicals.
Silo Vestibule	The center for raw product storage.
Treatment	Separation and HTST pasteurizing.
Pasteurized Storage	Storage of pasteurized skim milk and cream aging.
Churning	Butter churning.
Butter Packaging	Butter is packaged into 68 lb, 1 lb, 1/4 lb and continental wraps.
Cooler	Refrigerated storage for butter.
Grading	Grading area for plants selling butter to CCC.
Evaporator	Pasteurized skim and buttermilk are reduced to 48% solids.
Condensed Storage	Blends and condensed milk for bulk sale are processed and stored.
Dryer	Condensed products are powdered and bagged for storage.
Powder Storage	Warehousing for powdered products.
Lockers/Toilets	Facilities for labor force.
Lunch Room	Facilities for labor force.
Offices	Facilities for support staff.
Laboratory	Facilities for in-house laboratory work
Refg, Maint & Boiler	Provisioning for plant refrigeration, maintenance and boiler.
Dry Storage	Warehousing for supplies such as packaging, salt, etc.
CIP (Past. Side)	Clean-In-Place for the equipment used after pasteurization.

Data Generation

Using the description of plant activities found in Table 1 and the plant volumes from Table 3, the engineering firm of Mead & Hunt⁸ determined cost and/or unit values required for each of the 19 plants to be modeled. This portion of the study is a substantial

⁸ Mead & Hunt Inc., located in Madison, Wisconsin, are consulting engineers with comprehensive experience in the design of dairy plants.

effort as complete butter/powder plants must be engineered and thousands of calculations made to determine actual plant operation. Table 5 below lists the data categories that are evaluated by the engineers and provided to Cornell researchers. These data values are contained in a 200 page from Mead & Hunt.

Table 5. Data Categories

Category	Description
<u>Per Plant Center</u>	
STRUCTURAL	
Area	Square feet
Ceiling height	Feet
Fixed maintenance cost	Dollars/year
Variable maintenance cost	Dollars/operating hour
Construction cost	Dollars/square foot
EQUIPMENT	
Major pieces installed	Dollars
Minor pieces installed	Dollars
Maintenance & repairs	Dollars/operating hour
Description	Each piece
Dimensions	Each piece
Installed Cost	Dollars/each piece
Lifespan	Years/each piece
Maintenance Cost	Dollars/operating hour/piece
LABOR	
Fixed	Man hours/operating day
Variable	Man hours/operating day
Supervisory	Man hours/operating day
UTILITIES	
Gas-fixed	Therms/day
Gas-variable	Therms/operating hour
Electricity-fixed	kwh/day
Electricity-variable	kwh/operating hour
Water-fixed	Gallons/operating day
Water-variable	Gallons/operating hour
Sewer-fixed	Gallons/operating day
Sewer-variable	Gallons/operating hour
MATERIALS	
Cleaning supplies	Dollars/operating day
Packaging	Dollars/operating hour
Other	Dollars/operating day

(Table 5 continued...)

<u>Category</u>	<u>Description</u>
	<u>Per Plant</u>
LAND	
Land acres	Acres/10,000 sq ft building
Purchase price	Dollars/acre
BUILDING	
Total area	Square feet
Site work	Dollars/acre
GENERAL EXPENSES	
Accounting & Offices	Dollars/year
Communication & travel	Dollars/year
Insurance	Dollars/\$1000 investment cost
Property taxes	Dollars/\$1000 Property value
Laundry	Dollars/month
Services	Dollars/year
Telephone	Dollars/month
CONSTRUCTION	
Engineering Fees	% of total equipment and structure cost

Manufacturers and vendors provided the engineers with much of the equipment specific information that was needed; plant managers, working with Cornell and Mead & Hunt, helped to define present-day butter/powder plant practices. On average, the engineering data yielded more than 2,400 pieces of information per plant design or nearly 46,000 pieces of information in total. This large bulk of data is managed in a customized computer database. Utilizing this approach, it is easy to alter equipment configurations in a plant design to simulate technological changes. In like manner, parameters such as costs of capital, utilities, labor etc. can be readily updated to reflect new business environments.

Parameters Used

Cost of Capital

The recognition that firms would prefer to have a dollar today rather than a dollar tomorrow is referred to as the “time value of money”. It is an important concept in finance, often called the “cost of capital” or the “rate of discount”, and is explicitly recognized in business as an interest rate. A cost of capital is needed in this study to calculate the important category of depreciation and interest for a plant. The depreciation used here is not the same as that which is determined by accountants. Businesses that face income taxes will typically choose to depreciate the book value of their investments more rapidly than their intrinsic loss of value. The concept of an economic depreciation is employed in this study and is defined as the change in present values from one year to the next. Further, it is a real, not nominal, cost of capital that is used to transfer value through time. The real cost of capital is assumed to be 6% throughout the study.

Annual equivalent costs are calculated for every investment in the plant.⁹ This procedure is used because of unequal lives for many investments. Real costs of capital are necessary because, implicit in the calculation of annual equivalent costs, is the assumption that each item of equipment will be replaced at the end of its useful life by another item having the same cost and the same life. The annual equivalent cost may be defined as being the amount an investor would be indifferent to paying annually over the life of the investment versus the immediate outlay of the full cost.

Utility Rates

The engineering data for each plant center contains values for fixed and variable units of utilities used in that center. These are calculated from heating and lighting requirements for that portion of the plant and for the operation of every piece of equipment in that particular center. The building block approach sums these utilities over each plant

⁹ Appendix A contains example calculations of annual equivalent costs.

for a given level of plant capacity and determines the costs for utilities as the units used times the per unit cost. The values used in this study fall within the range of rates as determined in the survey of actual plants. They are assumed to be:

Gas — 38.11¢/therm
 Electricity — 5.99¢/kwh
 Water/Sewer — \$1.65/1000 gal.

Labor

Labor hours in a plant are the sum of the labor hours used in all plant centers. The man hours in any plant center are determined by fixed and variable values from the engineering data. The minimum hours for an operating plant are equal to one shift (8 hours). If the plant is operating at a capacity which requires more than one shift, up to two hours of overtime per shift may be worked, beyond that an additional shift is added. On average, labor is paid \$10.20 per hour and benefits are equivalent to 32% of the average wage. Overtime is paid 150% of the regular rate. Although the average wage is \$10.20 per hour, the actual wage varies from center to center. Table 6 below lists the wage distribution used throughout a plant. These values are consistent with the analysis of earlier survey data.

Table 6. Distribution of Wages

<u>Center</u>	<u>Hourly Wage</u>
Receiving	\$9.72
Treatment	\$10.19
Churning	\$10.25
Butter Packaging	\$8.93
Cooler	\$9.83
Evaporator	\$10.60
Dryer	\$10.47
Powder Storage	\$9.91
Offices	\$8.75
Laboratory	\$9.24
Refr. Maint & Boiler	\$10.93
Dry Storage	\$9.83
Supervision	\$13.95

Estimation of Costs

It is a straightforward proposition to determine total processing costs by simulating plants operating at various levels of capacity. For example, with no product flow through a plant, the total costs are the sum of the fixed costs (including annual equivalent costs). At levels of capacity greater than zero, the variable costs must be added for every operating hour. Although it is possible to know what the total processing costs and output pounds of butter and NDM are, it is not possible to assign a cost per pound of product using this straightforward approach.

Some of a plant's costs may be readily assigned to one product. For example, the fixed and variable costs incurred in the churning center are unique to butter production. However, it is not clear what portion of the fixed and variable costs in the refrigeration, maintenance and boiler center should be charged against a pound of butter. Because of these ambiguities, a statistical approach is used to disentangle the variable costs attributable to each product. Regression analysis is employed to estimate functions of the form:

$$\text{Total Costs} = \alpha + \beta_1(\text{lbs. butter}) + \beta_2(\text{lbs. NDM}) + \varepsilon$$

where:

α = the fixed costs

β_1 = the variable costs of a pound of butter

β_2 = the variable costs of a pound of NDM

ε = the error term

The use of regression analysis complicates the simulation of total costs in the plants. It is not enough to simulate the entire plant operating at various levels of capacity. If this were done then there would be perfect collinearity between the products produced. Successful regression requires covariance between the independent variables. To accomplish this, plants were centered on some percentage of plant capacity, say 50%, but production of each product was allowed to randomly vary $\pm 5\%$ from that centering point. The plant centers that are unambiguously aligned with one product are operated at the randomly centered percentage of capacity. Centers that are equivocal are assigned the average plant capacity. For example, the churning center may be operated at 47% of

capacity, the dryer at 54% of capacity, and refrigeration, maintenance and boiler at 50%. With this type of generated data, good statistical fits are ensured.

To determine the average total cost per pound of product, the fixed costs must be apportioned between the outputs. This is done by calculating the milk equivalents for the both the amount of butter and NDM produced. The fraction of fixed cost allocated to butter is determined to be the proportion of milk equivalent on a butter basis relative to the sum of milk equivalents on both bases. In like manner, the portion of fixed cost attributed to NDM is calculated. The fixed cost per pound of product is computed by dividing the parceled fixed costs by the pounds produced. Finally, the average cost per pound of product is the sum of the fixed cost per pound and the estimated variable cost per pound.¹⁰

Costs per hundredweight of milk processed are simulated more easily. Plants are operated at various levels of their capacity to process raw milk only—no outside cream is run through the plant. The total costs are simply divided by the cwt of milk run through the plant to yield the desired cost per cwt.

Results

Initial Capital Investments

The initial capital invested in the various plant configurations varies from just over 4 million dollars for a small plant producing only butter to nearly 19 million dollars for a large butter/powder operation. These plants were designed to be representative of efficient, modern plants, but do not incorporate technology that is so new as to be of questionable efficacy. Costs of equipment, materials and construction are 1989 values. Table 7 displays the construction, equipment, total and annual equivalent costs of the 19 plants that were engineered.

¹⁰ An example of these calculations are given in Appendix A.

Table 7. Capital Investments

Model Number ¹¹	Construction Costs	Equipment Costs	Total Capital Costs	Annual Equivalent Costs
1	\$3,051,913	\$6,068,115	\$9,120,028	\$723,810
2	\$3,630,208	\$7,632,639	\$11,262,847	\$893,606
3	\$4,455,922	\$8,901,303	\$13,357,225	\$1,053,690
4	\$5,531,371	\$11,186,817	\$16,718,188	\$1,321,137
5	\$7,075,069	\$11,919,245	\$18,994,314	\$1,479,095
6	\$1,425,876	\$2,849,385	\$4,275,261	\$414,153
7	\$1,533,131	\$3,536,351	\$5,069,482	\$496,677
8	\$4,031,304	\$8,770,034	\$12,801,338	\$1,070,804
9	\$5,964,905	\$12,639,212	\$18,604,117	\$1,542,822
10	\$3,705,926	\$7,845,789	\$11,551,715	\$922,950
11	\$5,491,626	\$11,445,406	\$16,937,032	\$1,346,867
12	\$3,476,184	\$7,352,229	\$10,828,413	\$867,833
13	\$4,440,589	\$10,758,642	\$15,199,231	\$1,231,160
14	\$3,493,677	\$7,550,089	\$11,043,766	\$892,114
15	\$4,433,316	\$11,004,321	\$15,437,637	\$1,257,106
16	\$3,504,624	\$7,010,974	\$10,515,598	\$828,875
17	\$5,325,307	\$10,498,956	\$15,824,263	\$1,243,045
18	\$4,157,809	\$8,527,035	\$12,684,844	\$1,000,348
19	\$6,701,759	\$11,859,084	\$18,560,843	\$1,451,130

Cost Comparison

These same nineteen plants are simulated to run at various levels of capacity. As a reference to realism, the percentage of total costs for several cost categories are compared to actual plant costs taken in a survey of existing butter/powder plants. Table 8 displays these cost comparisons.

¹¹ Refer to tables 1 & 3 for descriptions of plants. Plants 1-5 are the butter/powder base plants. Plants 6 and 7 are butter only plants.

Table 8. Percentage of Total Costs
In Simulated vs. Actual Plants

Cost Center	Simulated Plants	Actual Plants
Utility Cost	16%	17%
Labor Cost	31%	33%
Repair & Maintenance	11%	7%
Depreciation & Interest	26%	16%
Packaging	10%	19%
Cleaning	3%	3%
Tax, Insurance & Other	3%	5%

In most instances, the percentage of total costs compare very well between the engineered plants and the survey plants. Two categories of cost appear to be significantly different—Depreciation & Interest and Packaging.

It is postulated that the depreciation & interest charge in the simulated plants is greater than the actual plants because of the difference in calculation of the number. In the engineered plants, the depreciation value is an economic depreciation, meaning that the equipment is depreciated at the actual rate of devaluation. The accounting value taken from existing plants is an accelerated depreciation which is calculated to take advantage of the current tax structure. Older equipment in the actual plants is still very much in use, but carries little, if any, book value and may account for the differences between the simulated and actual plants.

The 9% difference in packaging costs is most likely the result of these comparison numbers being non-weighted averages of plant production. The survey plants are printing more butter in containers that are less than the 68 pound commercial size, with several survey plants packaging butter in relatively expensive individual portions. Although plants of this type are represented in the simulated plants, the nineteen configurations used to determine the percentages in the cost categories are packaging most of the butter in less expensive bulk containers.

Short and Long-Run Average Cost Curves

Each of the nineteen plants are simulated to run at capacities from 0-100% at 10% intervals. Because of the random components in the simulation, slightly different results are likely to be obtained at identical capacities (the random values are centered on the desired capacity). For this reason, each level of capacity was run six different times for a total of 66 observations on each of the nineteen plants. The data for each of the simulations include total costs, pounds of butter produced and pounds of NDM produced. Regressions of the type: Total Costs = $f(\text{lbs Butter, lbs NDM})$, yield the fixed and variable costs desired for each plant. All of these regressions have an R^2 greater than .95 and T-ratios greater than 2.0. Statistical significance can be arbitrarily improved to some degree by the generation of more data. Table 9 displays the results of these regressions for the five base plants.

Table 9. Estimated Fixed and Variable Costs
Per Pound in the Base Plants

Model #	Daily Fixed Costs	Variable Costs-Butter	Variable Costs-NDM
1	\$4090	\$0.0431	\$0.0731
2	\$4680	\$0.0326	\$0.0550
3	\$5246	\$0.0290	\$0.0489
4	\$6174	\$0.0261	\$0.0463
5	\$6706	\$0.0241	\$0.0437

The fixed costs are apportioned to the processing of either a pound of butter or NDM, and the costs per pound of product over the relevant ranges of production are determined.

Figure 3 plots the costs per pound of butter for the five base plants. All five plants are capable of processing up to 70,000 pounds of butter daily, and all five plants package butter in 68 lb bulk containers exclusively. Within this range, several observations can be made. First, the cost per pound in any plant processing no product is infinite. At low levels of production, say 10,000 pounds daily, plant #1 can process butter for 31.70¢ per lb while plant #5 incurs costs of 38.57¢ per lb for a range of 6.87¢ between the extreme plants. At the 70,000 pound level of daily production, plant #1 processes butter for 7.67¢ per lb while plant 5 pays 9.40¢ per pound for a range of 1.73¢. Although the range in

processing costs is decreasing as the daily quantity increases, plant #5 does not achieve a processing cost of 7.67¢ per pound until it processes more than 90,000 lbs of butter. There are large cost savings to be realized by processing larger volumes of butter.

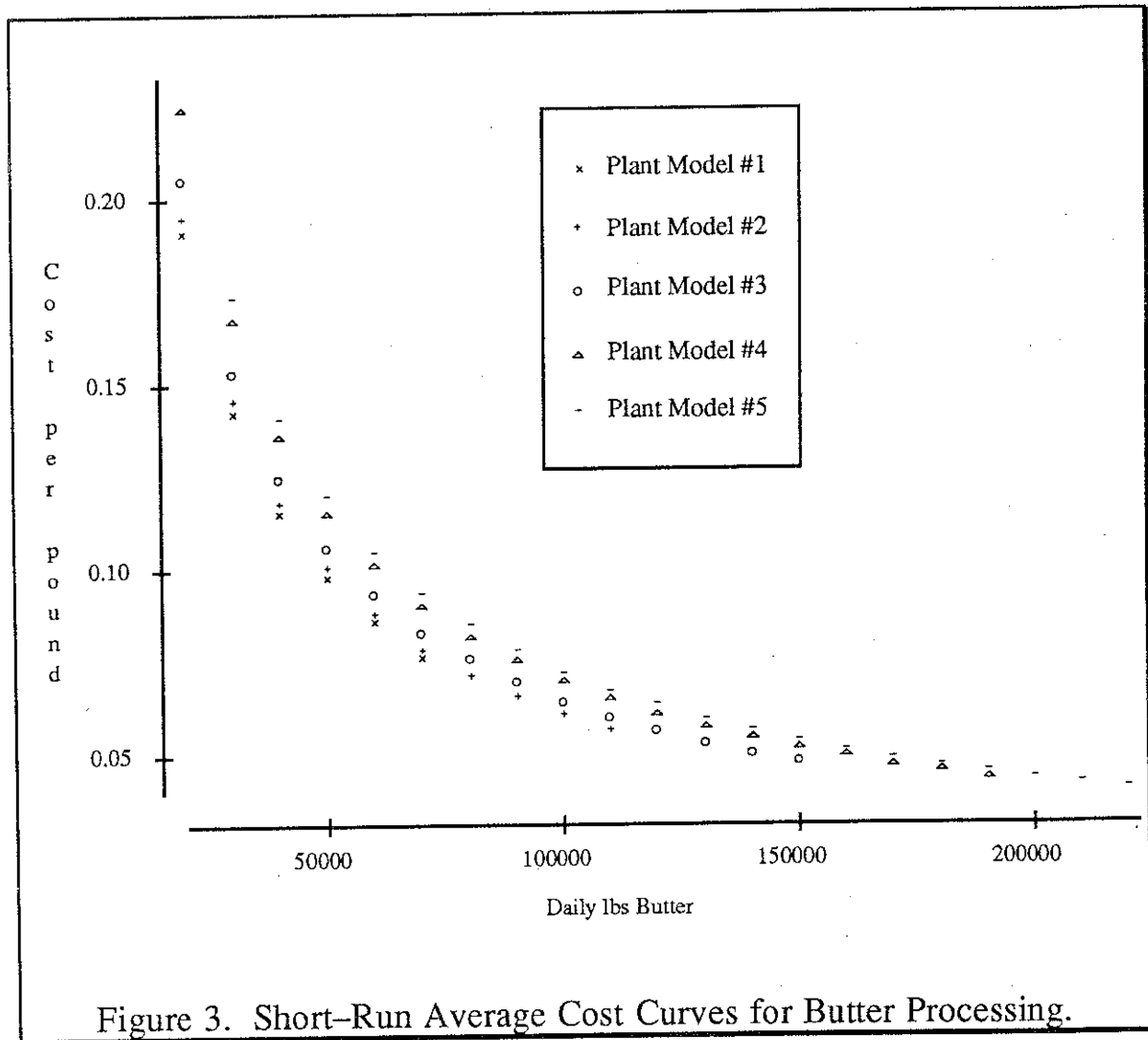

The long-run average cost of processing is determined as the collection of minimum achievable costs of production over all levels of output. In Figure 3, plant #1 has the minimum cost of production for all levels up to 80,000 pounds at which point plant #2 is the low cost processor. Plants continue to drop out of solution as they exceed their capacity to process. Each of the short-run and long-run average cost curves are estimated with regression analysis so that costs may be described by an equation. It can be seen that these curves are greatly non-linear. The values of both the dependent (cost per pound) and independent (daily pounds) variables are transformed as their natural logarithms for the

OLS estimation. The results in table 10 show the estimated coefficients used to determine the average costs for daily butter output in the five base plants.

Because the five base plants only package bulk butter, the costs in these plants are the minimum achievable costs over all engineered plants. Plant numbers 6–9 are plants that print equal proportions of butter in smaller packages. Each of these plants are engineered to process 33% of the butter produced as one pound solids, 33% as 1/4 pound sticks, 9% as continental wraps and the remaining 25% in 68 pound containers. Plants 6 and 7 do not take in raw milk but manufacture butter from outside cream only. Plants 8 and 9 are identical to base plants 2 and 4 in every aspect except that they print butter in these smaller packages. Figure 4 graphs these short-run average cost curves. Table 10 shows the estimated coefficients for these long and short-run average cost curves.

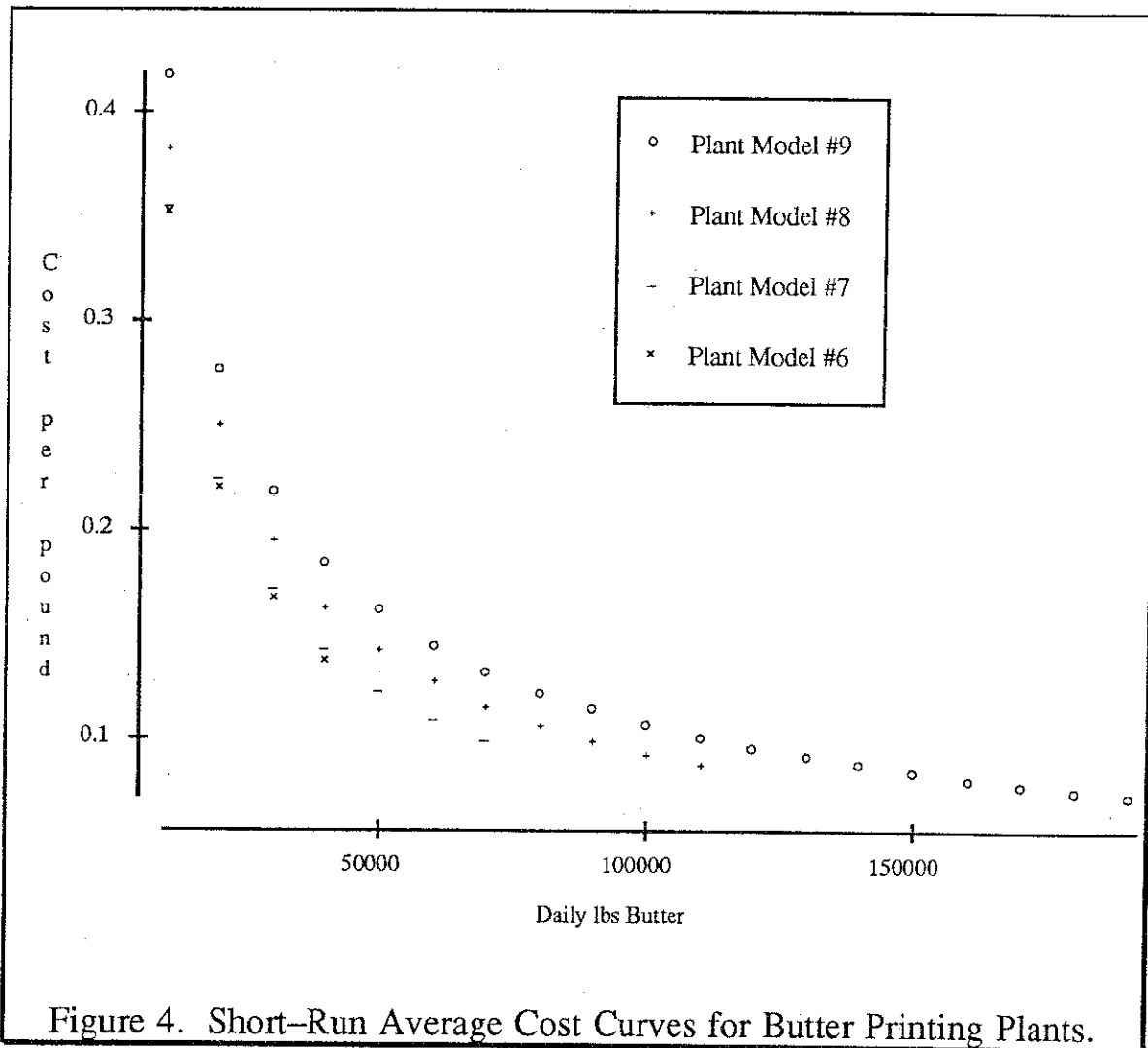

Table 10. Estimated Coefficients Used in Determining Average Costs Of Daily Butter Production

Equation	Relevant Range of Daily Production	α	β
SAC-Plant #1	0-76,016	5.56775	-0.729255
SAC-Plant #2	0-118,411	5.53928	-0.724255
SAC-Plant #3	0-152,031	5.55649	-0.721193
SAC-Plant #4	0-194,426	5.68757	-0.725152
SAC-Plant #5	0-228,047	5.73076	-0.725651
SAC-Plant #6	0-49,314	5.21804	-0.679683
SAC-Plant #7	0-79,889	4.97330	-0.653461
SAC-Plant #8	0-118,411	4.70789	-0.615480
SAC-Plant #9	0-194,426	4.59354	-0.593544
Long-Run Ave. Cost Plants 1-5	0-228,047	4.48515	-0.628033
Long-Run Ave. Cost Plants 6-9	0-194,426	3.25386	-0.485689

To calculate a cost per pound from Table 10, insert the values for α and β into the following formula:

$$\text{cost per pound} = e^{(\alpha + \beta * \ln(\text{daily pounds produced}))}$$

Where e is the natural exponential function and \ln is the natural logarithmic function. For example, to determine the average cost per pound of processing 50,000 lbs of butter in plant #1, the equation would be: $\text{cost per pound} = e^{(5.56775 - 0.729255 * \ln(50,000))}$ which is evaluated to be \$0.098 per pound.

The two long-run average cost curves in Table 10 represent the minimal achievable costs of two types of butter processing facilities—those that package only commercial butter and those that print typical quantities of retail packages. These two curves would be expected to bracket the true long-run average cost curves of butter production in the United States. Figure 5 plots these two long-run average cost curves as well as the one that was determined from the survey of actual plants. The relevant range in butter output is restricted to be from 10,000 to 60,000 lbs per day as the bulk of observations from the survey plants falls into this range.

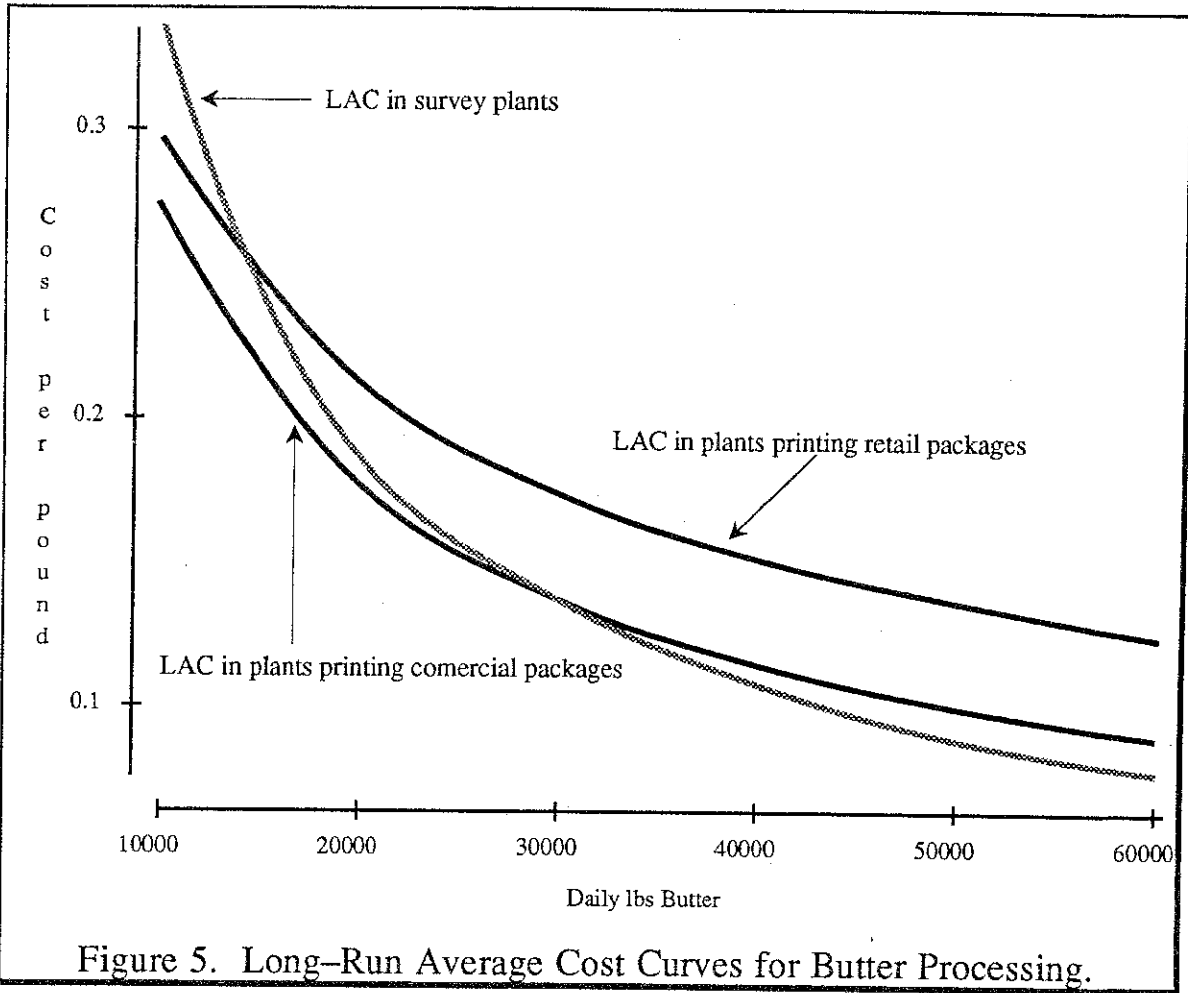

Figure 5. Long-Run Average Cost Curves for Butter Processing.

It can be seen that the long-run average costs in the survey plants are bracketed by the values from the engineered plants throughout a range of 14,600 to 28,200 pounds of daily output. In the 50,000 to 60,000 pound range the survey plants show costs of processing approximately 1¢ per pound less than the engineered plants. Large, modern processing plants are averaging production in this range. The differences between the survey plants and the engineered plants which account for the more curvilinear survey cost is that survey plants have relatively higher fixed and lower variable costs per pound.

The same type of calculations that have been used to determine the average costs of processing butter can be applied for the determination of processing costs of non-fat dry milk. Figure 6 plots the costs per pound of NDM for the five base plants. More than in butter processing, the "lumpiness" of equipment is prominently displayed in these short-run average cost curves. The smaller capacity evaporator and dryer in plant #1 does not require less manpower to operate than the larger pieces of equipment. As such, plant #1 is dominated at every level of production. Similarly, plants 4 and 5 are not enough different

in throughput to have distinction in the major pieces of equipment. Their cost curves are almost identical. The regression estimates of the coefficients for these short-run and the long-run average cost curves are given in Table 11.

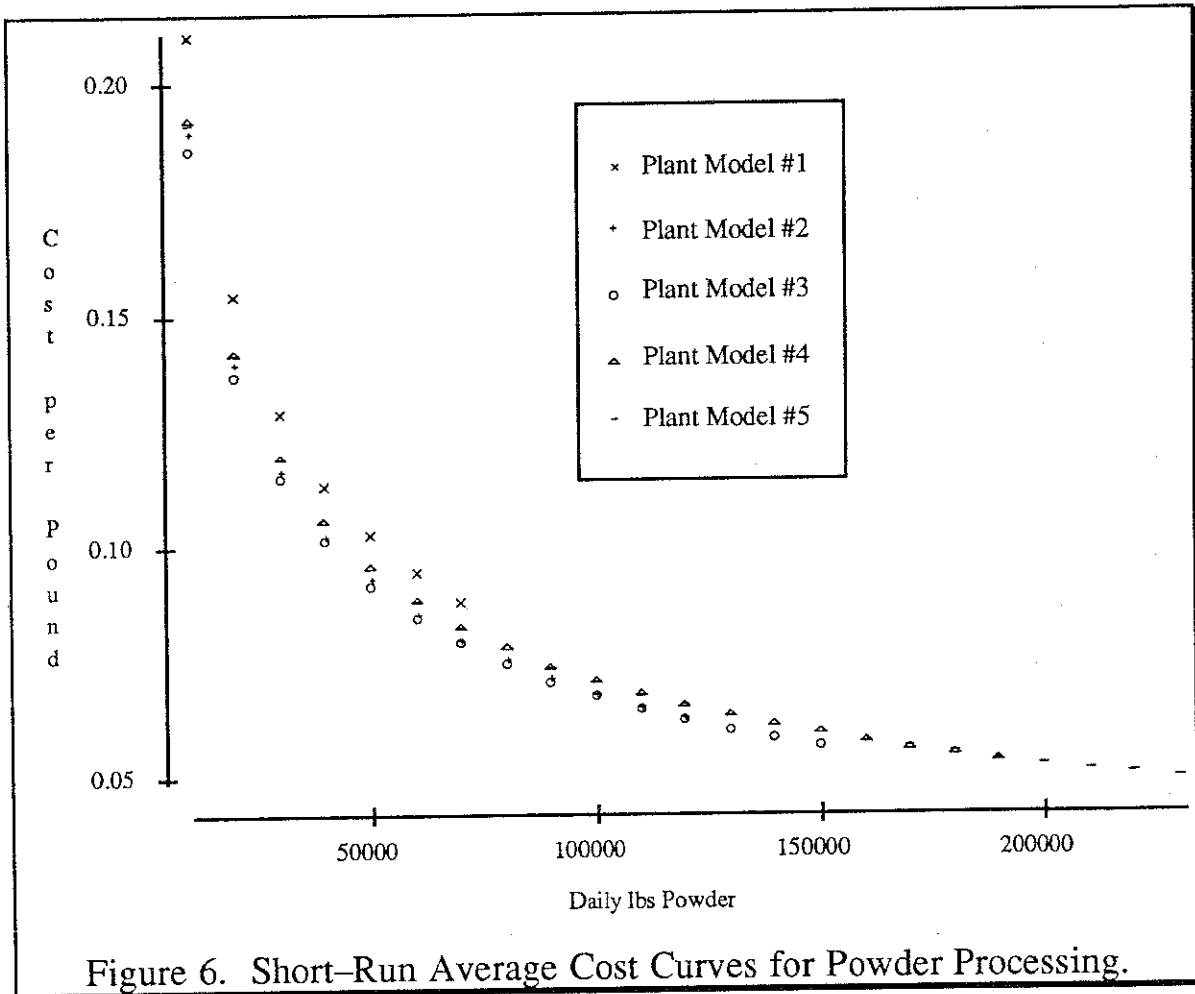

Figure 6. Short-Run Average Cost Curves for Powder Processing.

Table 11. Estimated Coefficients Used in Determining Average Costs Of Daily Powder Production

Equation	Relevant Range of Daily Production	α	β
SAC-Plant #1	0-78,194	2.56715	-0.448208
SAC-Plant #2	0-121,635	2.42267	-0.443672
SAC-Plant #3	0-156,388	2.37016	-0.440113
SAC-Plant #4	0-199,829	2.35074	-0.434577
SAC-Plant #5	0-234,582	2.31440	-0.431025
Long-Run Ave. Cost Plants 1-5	0-234,582	2.15883	-0.420096

The α and β coefficients in Table 11, are OLS estimates using the same functional form as those in the butter equations. To calculate a cost per pound from Table 10, insert the values for α and β into the following formula:

$$\text{cost per pound} = e^{(\alpha + \beta * \ln(\text{daily pounds produced}))}$$

Where e is the natural exponential function and \ln is the natural logarithmic function. For example, to determine the average cost per pound of processing 50,000 lbs of NDM in plant #1, the equation would be: $\text{cost per pound} = e^{(2.56715 - 0.448208 * \ln(50,000))}$ which is evaluated to be \$0.102 per pound.

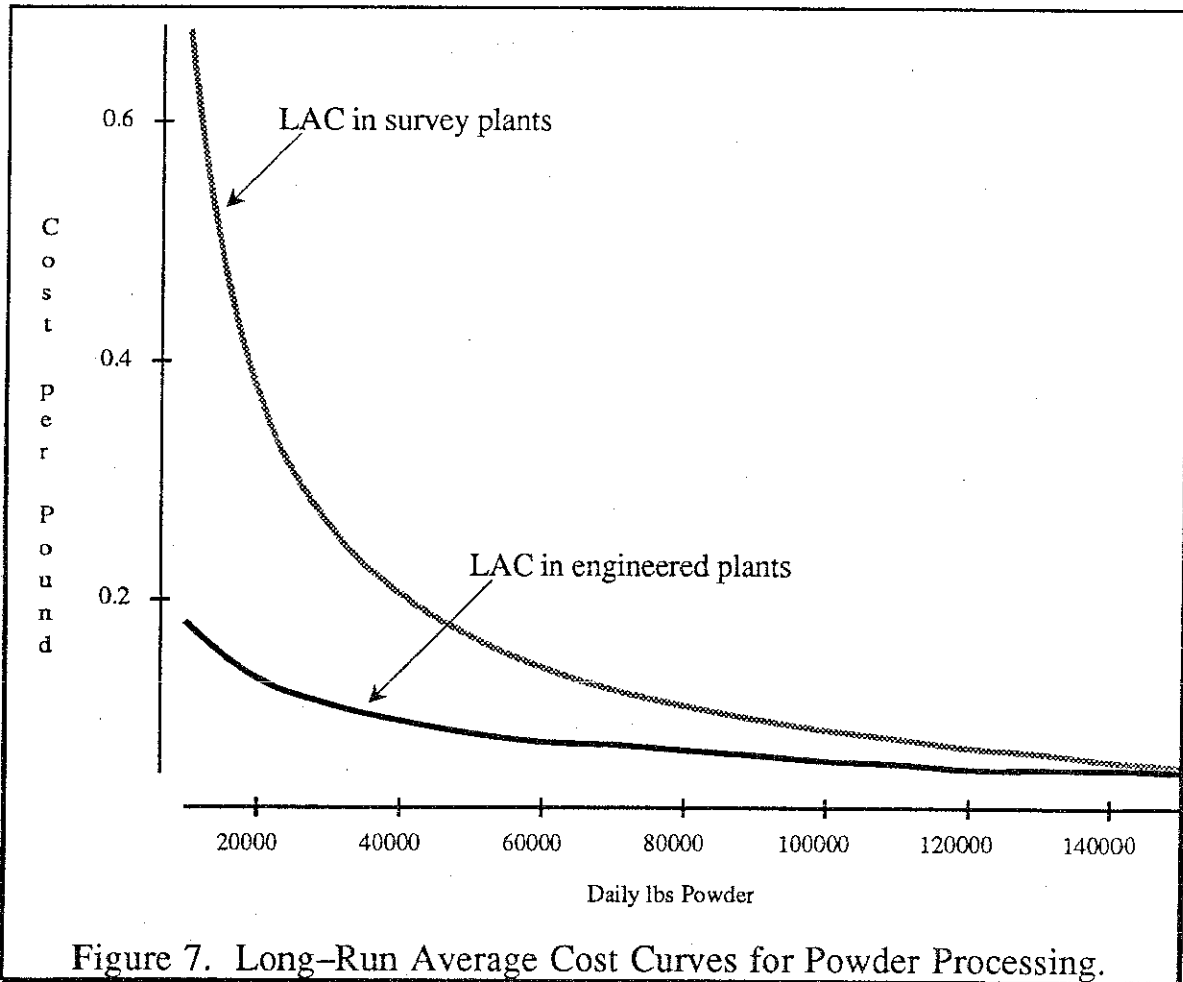
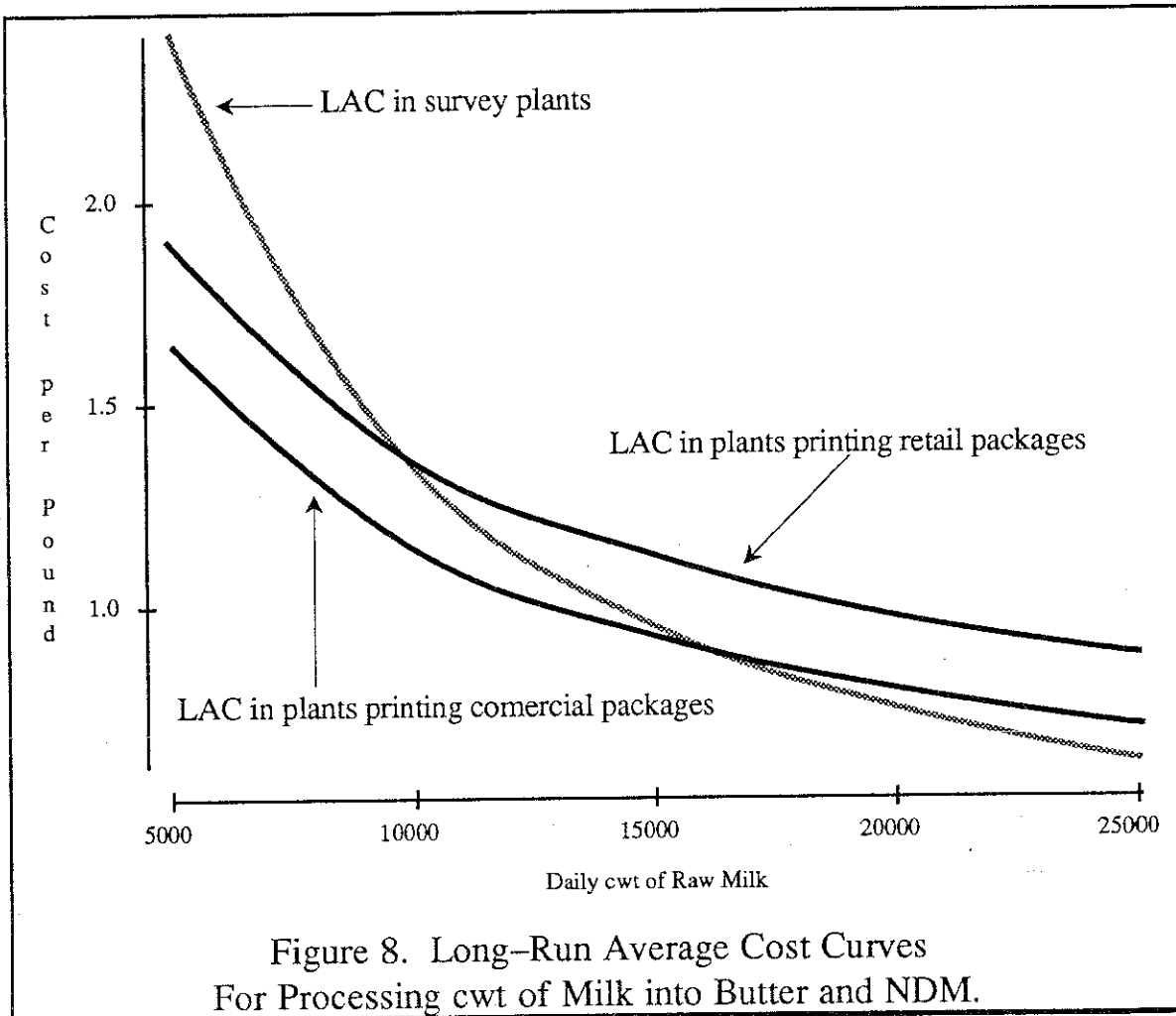

Figure 7. Long-Run Average Cost Curves for Powder Processing.

Figure 7 plots the long-run average cost curves calculated from base plants 1 through 5 and from the survey plants. It is clear that these equations provide different cost estimates at the lower ends of production. As with the butter curves, higher estimates of fixed costs in the survey plants account for this disparity. Unlike the butter curves, the variable costs are almost identical causing these two powder curves to converge over the relevant processing range rather than diverge as in the butter estimates.

Although the processes of manufacturing butter and NDM are separate, it is often convenient to know what the costs of processing a hundredweight (cwt) of raw milk into its respective products is. To accomplish this in the engineering study, the plants were simulated to operate with whole milk only. Plants 6 and 7, which operate exclusively with outside cream, are not considered in these calculations. Long-run average cost curves are determined from the short-run curves of plants 1-5 and 8-9. These are shown in Figure 8 as well as the estimate from the survey plants.



Again, the differences between the survey and engineering curves is due to higher fixed cost and lower variable cost estimates in the survey plants. The relevant range of observed processing in existing plants appears to center on 11,000 cwt of milk daily. This would place the estimated costs of processing in the survey plants squarely within the bounds of processing costs estimated from the engineering models. The functional form used in estimating the processing costs per cwt of milk are the same as those used for butter and

powder processing. The coefficients determined in the regression of the long-run average costs in the two types of engineering plants are given below in Table 12.

Table 12. Estimated Coefficients Used in Determining Average Costs Of Daily cwt of Milk Processed.

Equation	Relevant Range of Daily Production	α	β
Long-Run Ave. Cost Plants 1-5	0-27,000	4.98491	-0.527054
Long-Run Ave. Cost Plants 8 & 9	0-23,000	4.77945	-0.485222

Processing Environments Reflecting More and Less Cream Receipts

There is an assumption in base plants 1 through 5 that more cream is being processed than is separated from the raw milk. The amount of outside cream is based on average values from plants in the survey, however, the range surrounding this average value runs from almost no outside cream to approximately two times the average. A plant receiving only raw milk would process about half of the base plants' volume of butter. This variation on butter/powder processing might be observed in plants located some distance from metropolitan centers. The sources of most outside cream for butter processing are fluid milk plants which are typically located near populous areas. Butter plants located near large cities may process a great deal of surplus cream from these class I plants. As a comparison of these different processing environments, base plants 2 and 4 are engineered to process no outside cream and twice the average volume of outside cream.

As processor's receiving only raw milk, the daily fixed costs are lowered about 4% representing a savings of \$205 and \$248 in plants 2 and 4 respectively. Further, because of the reduced volume, processing costs are pared an additional 0.5649¢ and 0.5994¢ for every pound of cream difference between the base plants and this permutation. At full capacity, the daily total cost savings for these raw milk only plants are \$866 in plant 2 and \$1,400 in plant 4. Although there are total dollar savings in processing cost, there are also efficiencies foregone with smaller processing equipment raising, for example, the variable cost per pound of butter from 3.26¢ to 5.45¢ in plant #2. This, combined with the fact that

total fixed costs are not distributed over as many pounds of butter, results in the average processing cost per pound of butter rising from 5.39¢ to 8.32¢ in plant #2 and from 4.31¢ to 6.51¢ in plant 4.

Processing twice as much cream as the base plants yields an inverse image to the raw milk only modifications. Here plants 2 and 4 see a \$352 or \$381 increase in daily fixed costs from the larger capacity equipment in the plant. However, on a per pound basis at full capacity, these added costs are overcome by a reduction in variable costs. Although total costs of daily processing at 100% capacity rise \$1,366 in plant 2 and \$1,379 in plant 4, the processing cost per pound of butter declines 21% in both cases to 4.23¢ and 3.37¢.

Marketing Alternatives

Butter/powder plants need not warrant their existence as balancing and disposal facilities for unwanted products. There is a real demand for butter printed in commercial containers and nonfat dry milk in 50 pound bags. However, plants do face marketing opportunities for products in altered forms. Some alternatives are in the nature of product enhancements such as retail butter packaging. This type of marketing alternative generates additional processing costs that must be evaluated against the additional revenue that is expected from the value added product. Other marketing options, such as the sale of bulk condensed milk, reduce manufacturing costs by eliminating processing steps (powdering the product). Such an alternative must be evaluated against the loss in revenue expected from a less intensively manufactured output. This study does not evaluate profit potentials for any of the products considered but does appraise the changes in processing costs under several marketing alternatives. Plants 2 and 4 are used as models for comparison of several modifications in processing strategy.

Already considered in the section on short-run average cost curves, are the permutations in plants 2 and 4 to print butter in various retail packages. These altered plants are modeled to package 33% of the butter churned in one pound solid containers, 33% in 1/4 pound sticks, 25% in 68 pound commercial boxes, and 9% as continental wraps (continentals are individual restaurant-type portions).¹² It is determined that the addition of facilities, equipment, utilities, supplies and labor needed to print this quantity of butter

¹² The survey of existing plants found that on average, plants printing butter in retail packages did so in proportions similar to those listed.

would add \$507 dollars to the daily fixed cost as well as 3.09¢ per pound of butter to plant #2, and \$633 dollars to the daily fixed cost and 3.04¢ per pound of butter to plant #4.

Plants may have uses for cream other than churning butter. Manufacturers in some locations can market ice cream and milk shake mixes by blending cream with condensed milk coming off the evaporator. These products, known as blends, vary in composition but typically contain 22% butterfat and 25.5% solids-not-fat. They are blended by combining 46% condensed milk from the finisher (50% SNF) with 54% cream (40% butterfat). Plants 2 and 4 were modeled with down-sized churns reflecting the opportunity to market 20% of their available cream through the sale of blends. These plants incur some additional capital investment in blending and storage tanks for the product thus adding to the fixed costs in the plants. The reduction in churning volume allows smaller churns to be used, but the reduced volume of product through the drying center is not enough to move to a smaller spray drying unit. With these plants, it is determined that daily fixed costs are increased by \$120 and \$94 in plants 2 and 4 respectively. These increased costs are partially offset by a reduction in total costs equal to 0.1033¢ and 0.1543¢ in the two plants per pound of blends marketed. Given these values, plant 2 cannot achieve a break even cost until it markets more than 115,000 pounds of blend daily. This represents almost 30% more cream than the assumptions above, and indicates that blends are not a viable option for plant 2. On the other hand, plant 4 achieves a break even volume at 60,881 pounds which is just over 40% of the volume reflected in the assumptions. Blends are cost saving for plant #4.

Many plants that would not be able to develop a market for blended products may have the opportunity to sell bulk loads of condensed milk. This product is assumed to be pulled off the evaporator at 36% total solids. Tanker truck sales of this commodity do not provide plants with an alternate means of selling cream, however, a large amount of skim milk can be diverted from the drying center. Plants 2 and 4 are engineered with smaller dryers reflecting the diversion of half of the skim milk to sales of a condensed product. Because of the smaller dryers, there are net savings of fixed costs in both plants. Plant #2 sees a reduction of \$82 per day and plant 4 has \$337 daily savings. There are also savings of total costs equal to 0.2673¢ and 0.4893¢ per pound of condensed milk sold in the respective plants. At full capacity, this represents \$519 and \$1,651 savings daily.

If plants 2 and 4 are modeled to divert 20 % of their cream into blends and 50% of their skim milk into bulk condensed sales, then there is the possibility of even greater savings in processing costs. Under this scenario, plant #2 increases daily fixed costs by \$21 and reduces total costs by 0.2105¢ per pound of wet product (blends + condensed).

This is a cost saving of \$512 daily. Plant #4 decreases daily fixed costs by \$243 and saves an additional 0.3705¢ per pound of wet product for a total daily saving of \$1,782 at full capacity.

The Effects of Scale, Scheduling and Seasonality on Processing Cost

It is clear from the short and long-run average cost curves that there are benefits to be gained by strategic choices of plant size and levels of operational capacity. From the short-run average cost curves, it is observed that the minimum cost of processing at any given level of throughput is achieved by the plant operating nearest full capacity. It is further observed that there are large savings in processing cost to be had by processing larger quantities. However, it is not clear what the optimal combination of choices would be. Realistically, most butter/powder plants operate with fluctuating input levels throughout a week. Fluid processing plants are closely tied to butter/powder processing for two reasons. Fluid processors often dispose of excess cream through sales to butter plants while they are processing mid-week. And, on weekends, when they are not processing, the raw milk is often diverted to a butter/powder plant for balancing purposes. Daily average processing masks many of the decisions that a butter/powder plant manager must face. Is it more profitable to operate a plant that is just large enough to handle the "average" daily production and maintain storage for the intra-week fluctuations, or should the plant be larger and scaled to process product only three or four days a week and store the smaller intra-week accumulations?

These questions may be answered by considering the short-run average cost curves of the base plants. The smallest base plant, #1, is not included in this analysis as it is in some way an anomaly. The processing costs per pound of powder are found to be dominated at every level of output by all other plants. This would cause plant #1 to complicate discussions of scale. Using the other four plants to construct an example, identical volumes of products are processed using: plant #2 for 6 days, or plant #3 for 5 days, or plant #4 for 4 days, or plant #5 operating at full capacity for 3 days. Table 13 below shows the processing costs for each plant in this illustration.

Table 13. Effects of Scale and Scheduling on Processing Cost

	Pounds Processed per Day	% Daily Operating Capacity	Number of Processing Days/Week	Dollars Per Processing Day	Dollars Per Idle Day	Total Weekly Cost	Average Cost per Day
Plant 2: Butter NDM	114,024 117,291	96%	6	\$6,311 \$7,453	\$4,680	\$87,264	\$12,466
Plant 3: Butter NDM	136,828 140,749	90%	5	\$7,001 \$8,164	\$5,246	\$86,317	\$12,331
Plant 4: Butter NDM	171,035 175,937	88%	4	\$8,098 \$9,700	\$6,174	\$89,714	\$12,816
Plant 5: Butter NDM	228,047 234,582	100%	3	\$9,095 \$11,500	\$6,706	\$88,609	\$12,658

Generalizations regarding optimal scale/scheduling choices are difficult. A plant operating at 100% of capacity on processing days, as in plant 5 above, is not sufficient to guarantee least cost. Figure 9 shows isoquants for one level of production in plants 2–5. On this graph, every point on any line is an equivalent output. For example, plant #2 operating at 100% capacity three days a week has identical throughput to plant #5 operating at just under 40% capacity four days a week. The second graph, just below the isoquants, shows a great disparity in weekly processing costs from the two extreme points. Plant #5 processing 7 days a week will only operate at 22% of capacity and have expenses of \$73,000. Plant #2 processing 3 days a week will operate at 100% of capacity and have \$59,500 of expenses. Figure 9 also demonstrates the complexity which confounds “rules of thumb” for selecting optimal scale/scheduling tradeoffs. At the 40% level of capacity, it can be seen that any one of the four plants is capable of processing the products by operating different numbers of days per week. The ranking of low to high cost production of these plants is: plant #3 operating 6 days per week, plant #2 operating 7 days per week, plant #4 operating 5 days per week, and the high cost combination is plant #5 operating 4 days per week. The most general statement that can be made is: for any given plant, operating the fewest number of days per week is cost saving; and for any given number of days per week, the smallest plant capable of processing the required volume is cost saving.

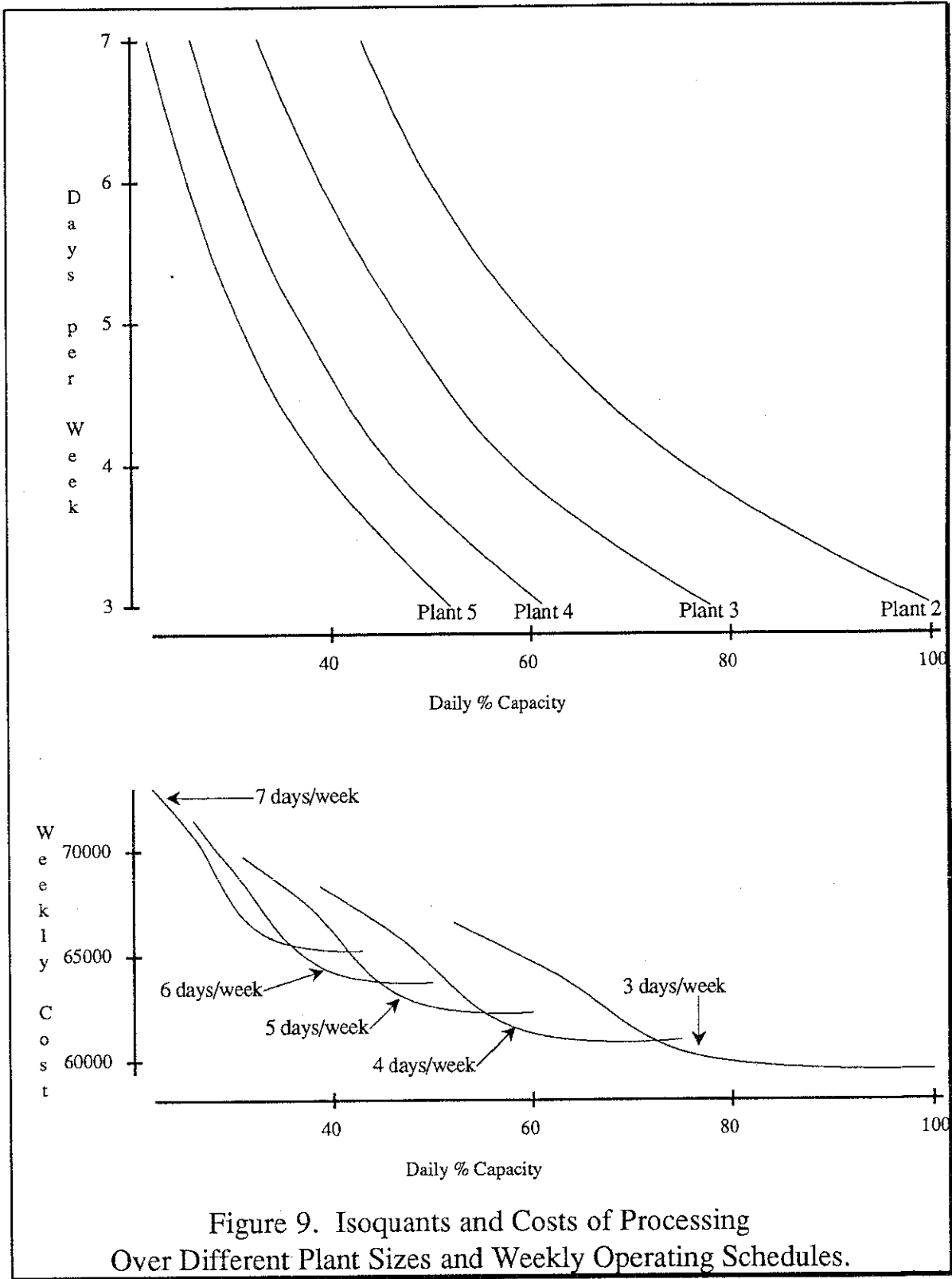

Figure 9. Isoquants and Costs of Processing Over Different Plant Sizes and Weekly Operating Schedules.

As intra-week fluctuations in supply affect costs of production, so do intra-year fluctuations. This problem, usually referred to as “seasonality”, may require a plant to operate non-optimally during much of the year. Table 14 considers the weekly cost of processing in different plants with different weekly scheduling and seasonal variation.

Table 14. Weekly Cost of Processing
With Seasonally Different Volumes.

Plant #	Days/Week	\$/Week		
		Flush Season	Normal Season	Short Season
2	7	\$105,742	\$85,474	\$65,206
2	6	na	\$84,061	\$63,793
2	5	na	\$82,648	\$62,380
2	4	na	na	\$60,967
2	3	na	na	\$59,554
3	7	\$102,163	\$84,068	\$65,972
3	6	\$100,700	\$82,605	\$64,509
3	5	na	\$81,142	\$63,046
3	4	na	\$79,679	\$61,583
3	3	na	na	\$60,120
4	7	\$104,553	\$87,667	\$70,781
4	6	\$102,993	\$86,107	\$69,221
4	5	\$101,433	\$84,547	\$67,661
4	4	na	\$82,987	\$66,101
4	3	na	na	\$64,541
5	7	\$104,690	\$88,833	\$72,975
5	6	\$103,112	\$87,255	\$71,397
5	5	\$101,534	\$85,677	\$69,819
5	4	\$99,956	\$84,099	\$68,241
5	3	na	\$82,521	\$66,663

The column labeled “Normal Season” represents an average level of processing to be done. Again, the optimal plant size would not be selected by choosing the smallest plant capable of processing the volume. Plant #3, operating at 78% capacity 4 days per week, is the least cost processor. At this volume, plant #2 is operating at 100% capacity 5 days per week

yet has weekly expenses that are almost \$3,000 dollars higher. The columns labeled "Flush Season" and "Short Season" represent processing volumes that are $\pm 40\%$ of the normal season. If plant #3 were operating in a non-seasonal environment, it would be processing the normal volume for 52 weeks and incur expenses totaling \$4,143,308 for the year. If one arbitrarily describes a seasonally operated plant as having 15 weeks of flush, 22 weeks of normal, and 15 weeks of short supplies, then choosing the best schedule for plant #3 in all seasons (these values are boxed) yields an annual expense of \$4,165,228. The seasonal component adds less than \$22,000 to the processing cost of the non-seasonal plant. This is only about one half of one percent of the operational cost. By comparison, choosing plant #2 over plant #3 would have added more than three percent to the low cost solution. It appears as though seasonal swings in operation are not as important as selection of the "optimal" plant size.

Affects of the Business Climate on Manufacturing Costs

The processing environment contributes in a significant way to the costs of production. For example, it was shown in Table 8 that labor accounts for more than 30% of the total costs of processing in the simulated plants. It would be expected then that a 10% change in wages would translate to approximately 3% change in total costs, however, there are differences in the sensitivity of the different plants to such a change. It can be seen in Table 15 that the range is from more than 3% to less than 2% and in general the sensitivity declines from small to larger plants. In contrast, the sensitivity of the cost of capital increases from small to large scale processors. Taken together, this is an indication that larger plants are substituting capital for labor. Another indication of capitalization in plants of increasing size is the increased sensitivity to a change in utility rates. A 10% increase in all utility rates causes a 1.16% increase in plant 1 and a 1.74% increase in plant 5's cost of production.

It was found in the survey of existing plants that butterfat losses of 2% and solids-fat losses of 0.5% were typical but not uniform. Some plants had butterfat shrinkage as low as 1% and SNF losses as high as 1%. Controlling these losses in a plant does not affect total costs but the cost per pound of product is directly altered. The sensitivity of yield is also explored in Table 15 where it is found cutting losses by half would be expected to lower the cost per pound by less than 3% in all plants.

Table 15. Sensitivity in Processing Costs to Parameter Changes

	Parameter Changed	% Change in \$/lb Butter	% Change in \$/lb NDM	% Change in Total Costs
Plant 1	plus 10% Capacity ¹³	-5.78%	-2.13%	7.05%
	minus 10% Capacity	7.22%	2.67%	-7.05%
	10% Cost of Capital			1.12%
	10% Average Wage			3.32%
	10% Gas Cost			0.36%
	10% Electric Cost			0.67%
	10% Water/Sewer Cost			0.13%
	10% Yield ¹⁴	-0.25%	-0.05%	0.00%
	Plant 2	plus 10% Capacity	-5.57%	-2.06%
minus 10% Capacity		6.96%	2.57%	-7.19%
10% Cost of Capital				1.16%
10% Average Wage				2.90%
10% Gas Cost				0.57%
10% Electric Cost				0.74%
10% Water/Sewer Cost				0.31%
10% Yield		-0.25%	-0.05%	0.00%
Plant 3		plus 10% Capacity	-5.29%	-2.02%
	minus 10% Capacity	6.62%	2.53%	-7.31%
	10% Cost of Capital			1.21%
	10% Average Wage			2.46%
	10% Gas Cost			0.64%
	10% Electric Cost			0.66%
	10% Water/Sewer Cost			0.34%
	10% Yield	-0.25%	-0.05%	0.00%
	Plant 4	plus 10% Capacity	-5.41%	-1.95%
minus 10% Capacity		6.77%	2.44%	-7.35%
10% Cost of Capital				1.26%
10% Average Wage				2.19%
10% Gas Cost				0.61%
10% Electric Cost				0.78%
10% Water/Sewer Cost				0.35%
10% Yield		-0.25%	-0.05%	0.00%

¹³ Plants in this table are operating at 90% of their capacity. Changes in capacity are shown as both plus and minus 10% because the average cost curves are not linear. I.e., the change to lower capacity (80%) has a greater absolute affect on cost per pound of butter and NDM than a 10% change in the opposite direction.

¹⁴ This table assumes a 2% loss in butterfat and a 0.5% loss in solids-not-fat as the norm. A 10% improvement in the yield would constitute a 1.8% loss in butterfat and a 0.45% loss in SNF. These improvements do not change total processing costs in the plants, however, they do affect the cost per pound of product produced.

(Table 15 continued)...

Plant 5	plus 10% Capacity	-5.21%	-1.93%	7.44%
	minus 10% Capacity	6.51%	2.41%	-7.44%
	10% Cost of Capital			1.31%
	10% Average Wage			1.98%
	10% Gas Cost			0.60%
	10% Electric Cost			0.81%
	10% Water/Sewer Cost			0.33%
	10% Yield	-0.25%	-0.05%	0.00%
Plant 6	plus 10% Capacity	-4.00%	NA	6.67%
	minus 10% Capacity	5.00%	NA	-6.67%
	10% Cost of Capital			0.95%
	10% Average Wage			2.46%
	10% Gas Cost			0.16%
	10% Electric Cost			0.71%
	10% Water/Sewer Cost			0.04%
	10% Yield	-0.25%	NA	0.00%
Plant 7	plus 10% Capacity	-3.58%	NA	7.14%
	minus 10% Capacity	4.47%	NA	-7.14%
	10% Cost of Capital			0.90%
	10% Average Wage			1.96%
	10% Gas Cost			0.19%
	10% Electric Cost			0.50%
	10% Water/Sewer Cost			0.04%
	10% Yield	-0.25%	NA	0.00%

Evaluation of the Economic Engineering Approach

In this study, implementation of the economic engineering approach has been made with caution. Critics point out that the results cannot often be compared with other sources and that the danger of overlooking important costs or oversimplifying technical relationships and thus underestimating total costs is very real. A detailed survey of existing plants was first conducted to aid in the specification of plant parameters. Further, an advisory panel of industry personnel has provided cross checks for realism at every step along the way. The plant capacities that were chosen to be modeled span a range that might be labeled from medium to large when compared with existing plants. However, the continued consolidation of existing butter/powder operations into larger units, place these simulated plants within a sensible range. An engineering firm, with a long reputation in dairy processing plant design, was employed to provide the raw data used in generating the

costs. And finally, the survey is a current and excellent source by which the engineering results may be evaluated.

Within the relevant range of production (as determined by the survey) the costs per cwt of raw milk processed are nearly identical in the real and simulated plants. Outside that range, the survey and actual plants differ in a way indicative of higher fixed and lower variable costs in the survey plants. Analysis of the actual plant data determined that costs were highly fixed, ranging from \$3,000 to \$37,000 and averaging \$11,000 per day. On average, the total costs in the survey plants were about 80% fixed. In the engineered plants, the average fixed cost is calculated to be about \$5,400 or 38% of total cost for production in same range. It might be anticipated that the engineered plants would have a more highly fixed cost when compared with the survey plants given the larger fixed values for depreciation and interest.¹⁵ Because the difference in fixed cost between the two studies is significant and in an unexpected direction, it probably indicates realities of business that have not been fully appreciated in the engineering study. Every plant center in an engineered plant is given a fixed and variable value for labor hours required. Over all centers in all plants, labor hours are determined to be about 50% fixed. In the survey plants, labor is actually calculated to be about 85% fixed. It is probable that the difficulty involved in securing and training temporary labor in most locations precludes the degree of variability achieved in the simulated plants.

Although the reliability of an economic engineering analysis may be questioned as a predictor of actual costs outside the relevant range of production, it is a valuable means of addressing otherwise unanswerable questions. With computer simulation it is possible to “operate” plants under extreme conditions while controlling the “business” environment. This yields results that span a much larger range than is actually observed while maintaining comparability between plants. With this approach, researchers are able to provide valuable insights into operational goals for management or selection of actual plants. If a requirement of a piece of research is to replicate existing plants then the survey approach appears to be a sound, inexpensive and non-controversial approach. On the other hand, if research is considering questions of the type “what ought to be” then the economic engineering approach may be non-contestable.

¹⁵ Depreciation in the engineered plants is calculated as an economic depreciation. This differs from the accounting value of the surveyed plants in that it is not an accelerated rate used to capture tax advantages. See discussion of Table 8.

Appendix A

Calculations of Annual Equivalent Costs and Cost Per Pound

Annual Equivalent Costs

Annual equivalent costs are used in this study to determine depreciation and interest values in the plants. All capital investments (plant and equipment), whose expected lives are unequal, are made comparable by this calculation. The concept is that a firm would be indifferent between the immediate outlay of the entire cost and an annual outlay of the annual equivalent cost each year for the entire life of the investment. Annual equivalent costs are calculated as follows:

$$\text{Annual Equivalent Cost} = \frac{\text{Cost}}{\left(\frac{1 - (1 + r)^{-n}}{r} \right)}$$

where: Cost = purchase price of the investment

r = cost of capital

n = years of investment life

For example, a churn capable of 5000 lbs per hour butter throughput has a purchase price of \$450,000 and a useful life of 20 years. If the real cost of capital is 6% or 0.06 then the calculation is:

$$\begin{aligned} \text{Annual Equivalent Cost} &= \frac{\$450,000}{\left(\frac{1 - (1 + 0.06)^{-20}}{0.06} \right)} = \frac{\$450,000}{\left(\frac{1 - (1.06)^{-20}}{0.06} \right)} \\ &= \frac{\$450,000}{\left(\frac{1 - (0.3118)}{0.06} \right)} = \frac{\$450,000}{\left(\frac{0.6882}{0.06} \right)} \\ &= \frac{\$450,000}{(11.4699)} = \$39,233 \end{aligned}$$

Costs Per Pound of Product and cwt of Raw Milk

—Assumptions:

—cwt of raw milk yields 4.34 pounds of butter, 8.69 pounds of NDM.¹⁶

—Definitions:

DB = daily pounds of butter produced.

DP = daily pounds of powdered NDM produced.

VB = variable costs of producing a pound of butter.¹⁷

VP = variable costs of producing a pound of powder.

FC = daily fixed costs.

BR = the proportion of milk equivalent processed as butter.¹⁸

PR = the proportion of milk equivalent processed as NDM (equal to 1-BR).

CWT = the number of cwt raw milk processed daily.

$$\$/\text{lb of Butter} = \frac{(DB \times VB) + (FC \times BR)}{DB}$$

$$\$/\text{lb of Powder} = \frac{(DP \times VP) + (FC \times PR)}{DP}$$

$$\$/\text{cwt of Milk} = \left(\frac{FC}{CWT} \right) + (VB \times 4.34) + (VP \times 8.69)$$

¹⁶ Composition of raw milk is as defined in Table 2 providing the theoretical yields found in Figure 1.

¹⁷ The variable and fixed costs are determined in regression analysis where Total Costs = $f(\text{lbs butter, lbs NDM})$.

¹⁸ This value is used to determine how much of the fixed cost should be charged to butter. It is calculated by first determining the ME for a plant on a butterfat basis (MEb) and the ME on a solids-not-fat basis (MEs). BR is then equal to MEb divided by (MEb+MEs). For example if a plant processes 118,411 pounds of butter and 121,635 pounds of NDM daily then: MEb = $(118,411 / 0.0434) = 2,728,364$ lbs and MEs = $(121,635 / 0.0869) = 1,399,712$ lbs. BR = $(2,728,364 / (2,728,364 + 1,399,712)) = 0.66$ and PR = $1.0 - 0.66 = 0.34$

Appendix B

Regression Estimates of the Simulated Plants

Table 16. Breakdown of Daily Throughput in Plants Operating at 100% of Capacity

	Plant 1	Plant 2	Plant 3	Plant 4	Plant 5	Plant 6	Plant 7	Plant 8	Plant 9
Milk Received	900,000	1,400,000	1,800,000	2,300,000	2,700,000	0	0	1,400,000	2,300,000
Cream Received	75,000	117,000	150,000	192,000	225,000	100,000	162,000	117,000	192,000
lbs/day Cream	154,145	240,115	308,290	394,260	462,436	100,000	162,000	240,115	394,260
lbs/day Skim	820,952	1,277,037	1,641,905	2,097,989	2,462,857	0	0	1,277,037	2,097,989
lbs/day Bulk Cond	0	0	0	0	0	0	0	0	0
lbs/day Bulk Blends	0	0	0	0	0	0	0	0	0
lbs/day Butter	76,016	118,411	152,031	194,426	228,047	49,314	79,889	118,411	194,426
lbs/day Buttermilk	77,597	120,875	155,195	198,472	232,792	50,340	81,551	120,875	198,472
lbs/day Cond (40%)	189,230	294,357	378,459	483,587	567,689	0	0	294,357	483,587
lbs/day Cond (50%)	151,384	235,486	302,767	386,869	454,151	0	0	235,486	386,869
lbs/day Cond B'milk	15,054	23,450	30,108	38,504	45,162	0	0	23,450	38,504
lbs/day NDM	78,194	121,635	156,388	199,829	234,582	0	0	121,635	199,829
lbs/day B'milk Powder	7,776	12,112	15,552	19,888	23,327	0	0	12,112	19,888

	Plant 10	Plant 11	Plant 12	Plant 13	Plant 14	Plant 15	Plant 16	Plant 17	Plant 18	Plant 19
Milk Received	1,400,000	2,300,000	1,400,000	2,300,000	1,400,000	2,300,000	1,400,000	2,300,000	1,400,000	2,300,000
Cream Received	117,000	192,000	117,000	192,000	117,000	192,000	0	0	234,000	384,000
lbs/day Cream	240,115	394,260	240,115	394,260	240,115	394,260	123,115	202,260	357,115	586,260
lbs/day Skim	1,277,037	2,097,989	1,277,037	2,097,989	1,277,037	2,097,989	1,277,037	2,097,989	1,277,037	2,097,989
lbs/day Bulk Cond	0	0	163,532	268,659	163,532	268,659	0	0	0	0
lbs/day Bulk Blends	89,352	146,713	0	0	89,352	146,713	0	0	0	0
lbs/day Butter	94,729	155,541	118,411	194,426	94,729	155,541	60,713	99,743	176,108	289,110
lbs/day Buttermilk	96,700	158,778	120,875	198,472	96,700	158,778	61,976	101,818	179,773	295,125
lbs/day Cond (40%)	294,357	483,587	289,459	475,539	289,459	475,539	294,357	483,587	294,357	483,587
lbs/day Cond (50%)	235,486	386,869	117,743	193,435	117,743	193,435	235,486	386,869	235,486	386,869
lbs/day Cond B'milk	18,760	30,803	23,450	38,504	18,760	30,803	12,023	19,753	34,876	57,254
lbs/day NDM	100,289	164,780	60,818	99,915	39,472	64,866	121,635	199,829	121,635	199,829
lbs/day B'milk Powder	9,690	15,911	12,112	19,888	9,690	15,911	6,210	10,203	18,014	29,574

Table 17. Regression Estimates of Daily Fixed and Variable Costs

Plant	Maximum Plant Capacity	Characteristics	Daily Fixed Costs	Variable Costs per lb. Butter	Variable Costs per lb. NDM
1	900,000 lbs milk 75,000 lbs cream	Base Plant	\$4,091	\$0.043120	\$0.073100
2	1,400,000 lbs milk 117,000 lbs cream	Base Plant	\$4,681	\$0.032611	\$0.054983
3	1,800,000 lbs milk 150,000 lbs cream	Base Plant	\$5,247	\$0.028951	\$0.048872
4	2,300,000 lbs milk 192,000 lbs cream	Base Plant	\$6,175	\$0.026060	\$0.046289
5	2,700,000 lbs milk 225,000 lbs cream	Base Plant	\$6,706	\$0.024057	\$0.043653
6	butter only from 100,000 lbs cream	Retail Butter Packaging	\$2,343	\$0.086202	NA
7	butter only from 162,000 lbs cream	Retail Butter Packaging	\$2,643	\$0.068652	NA
8	1,400,000 lbs milk 117,000 lbs cream	Retail Butter Packaging	\$5,187	\$0.063547	\$0.054992
9	2,300,000 lbs milk 192,000 lbs cream	Retail Butter Packaging	\$6,808	\$0.056439	\$0.046297
10 ¹⁹	1,400,000 lbs milk 117,000 lbs cream	Bulk Blends	\$4,801	\$0.039283	\$0.067147
11 ¹⁹	2,300,000 lbs milk 192,000 lbs cream	Bulk Blends	\$6,271	\$0.030976	\$0.056247
12 ¹⁹	1,400,000 lbs milk 117,000 lbs cream	Bulk Condensed	\$4,601	\$0.032595	\$0.102760
13 ¹⁹	2,300,000 lbs milk 192,000 lbs cream	Bulk Condensed	\$5,842	\$0.025903	\$0.079639
14 ¹⁹	1,400,000 lbs milk 117,000 lbs cream	Bulk Blends & Condensed	\$4,704	\$0.039263	\$0.159433
15 ¹⁹	2,300,000 lbs milk 192,000 lbs cream	Bulk Blends & Condensed	\$5,938	\$0.060784	\$0.122975
16	1,400,000 lbs milk no cream	Raw Milk Only	\$4,476	\$0.054510	\$0.054087
17	2,300,000 lbs milk no cream	Raw Milk Only	\$5,925	\$0.041630	\$0.045100
18	1,400,000 lbs milk 234,000 lbs cream	Two Times Cream Receipts	\$5,034	\$0.024858	\$0.059165
19	2,300,000 lbs milk 384,000 lbs cream	Two Times Cream Receipts	\$6,557	\$0.019881	\$0.048714

¹⁹ The variable costs for butter and NDM are inflated in these plants because regression estimates for Blends and/or Condensed milk were highly collinear with butter and NDM. Butter and/or NDM estimates are "picking up" the added cost of processing these other products.

Table 18. Regression Estimates of the Short-Run Average Costs
Of Butter Production²⁰

Plant ²¹	Maximum Plant Intake Capacity	Characteristics	Maximum daily butter production	α	β
1	900,000 lbs milk 75,000 lbs cream	Base Plant	76,016	5.56775	-0.729250
2	1,400,000 lbs milk 117,000 lbs cream	Base Plant	118,411	5.53928	-0.724255
3	1,800,000 lbs milk 150,000 lbs cream	Base Plant	152,031	5.55649	-0.721193
4	2,300,000 lbs milk 192,000 lbs cream	Base Plant	194,426	5.68757	-0.725152
5	2,700,000 lbs milk 225,000 lbs cream	Base Plant	228,047	5.73076	-0.725651
6	butter only from 100,000 lbs cream	Retail Butter Packaging	49,314	5.21804	-0.679683
7	butter only from 162,000 lbs cream	Retail Butter Packaging	79,889	4.97330	-0.653461
8	1,400,000 lbs milk 117,000 lbs cream	Retail Butter Packaging	118,411	4.70789	-0.615480
9	2,300,000 lbs milk 192,000 lbs cream	Retail Butter Packaging	194,426	4.59390	-0.593544
16	1,400,000 lbs milk no cream	Raw Milk Only	60,713	5.17872	-0.695857
17	2,300,000 lbs milk no cream	Raw Milk Only	99,743	5.39276	-0.705802
18	1,400,000 lbs milk 234,000 lbs cream	Two Times Cream Receipts	176,108	5.72709	-0.735910
19	2,300,000 lbs milk 384,000 lbs cream	Two Times Cream Receipts	289,110	5.84673	-0.734502

²⁰ The estimates of α & β are from an equation of the form: $\ln(\text{cost per pound}) = f(\ln(\text{pounds}))$. To determine the average cost per pound at some level of daily production, insert the values into an equation of the form: $\text{cost per pound} = e^{(\alpha + \beta \ln(\text{daily pounds produced}))}$. The daily pounds should not exceed the maximum daily capacity of the plant shown in the table.

²¹ Models 10-15 are not included in these estimates. These plants, which also produce Blends & Condensed milk, have highly collinear estimates and bias the results for short-run average cost curves.

Table 19. Regression Estimates of the Short-Run Average Costs
Of NDM Production²²

Plant ²³	Maximum Plant Intake Capacity	Characteristics	Maximum daily NDM production	α	β
1	900,000 lbs milk 75,000 lbs cream	Base Plant	78,194	2.56715	-0.448208
2	1,400,000 lbs milk 117,000 lbs cream	Base Plant	121,635	2.42267	-0.443672
3	1,800,000 lbs milk 150,000 lbs cream	Base Plant	156,388	2.37016	-0.440113
4	2,300,000 lbs milk 192,000 lbs cream	Base Plant	199,829	2.35074	-0.434577
5	2,700,000 lbs milk 225,000 lbs cream	Base Plant	234,582	2.31440	-0.431025
8	1,400,000 lbs milk 117,000 lbs cream	Retail Butter Packaging	121,635	2.67721	-0.463581
9	2,300,000 lbs milk 192,000 lbs cream	Retail Butter Packaging	199,829	2.60078	-0.453471
16	1,400,000 lbs milk no cream	Raw Milk Only	121,635	3.45014	-0.526424
17	2,300,000 lbs milk no cream	Raw Milk Only	199,829	3.43953	-0.519783
18	1,400,000 lbs milk 234,000 lbs cream	Two Times Cream Receipts	121,635	1.76837	-0.385297
19	2,300,000 lbs milk 384,000 lbs cream	Two Times Cream Receipts	199,829	1.67476	-0.378322

²² The estimates of α & β are from an equation of the form: $\ln(\text{cost per pound}) = f(\ln(\text{pounds}))$. To determine the average cost per pound at some level of daily production, insert the values into an equation of the form: $\text{cost per pound} = e^{(\alpha + \beta * \ln(\text{daily pounds produced}))}$. The daily pounds should not exceed the maximum daily capacity of the plant shown in the table.

²³ Models 6-7 and 10-15 are not included in these estimates. Plants 6 and 7 are inappropriate as they are butter only plants. Plants 10-15, which produce Blends & Condensed milk, have highly collinear estimates with butter and NDM values and bias the results for short-run average cost curves.

Table 20. Regression Estimates of the Short-Run Average Costs
Of Processing cwt Raw Milk²⁴

Plant ²⁵	Maximum Plant Intake Capacity	Characteristics	Maximum daily cwt production	α	β
1	900,000 lbs milk 75,000 lbs cream	Base Plant	9,000	5.62247	-0.595754
2	1,400,000 lbs milk 117,000 lbs cream	Base Plant	14,000	5.54363	-0.590502
3	1,800,000 lbs milk 150,000 lbs cream	Base Plant	18,000	5.52914	-0.586647
4	2,300,000 lbs milk 192,000 lbs cream	Base Plant	23,000	5.58203	-0.584902
5	2,700,000 lbs milk 225,000 lbs cream	Base Plant	27,000	5.58417	-0.582702
8	1,400,000 lbs milk 117,000 lbs cream	Retail Butter Packaging	14,000	5.32745	-0.548263
9	2,300,000 lbs milk 192,000 lbs cream	Retail Butter Packaging	23,000	5.25602	-0.531450
16	1,400,000 lbs milk no cream	Raw Milk Only	14,000	5.68884	-0.603161
17	2,300,000 lbs milk no cream	Raw Milk Only	23,000	5.77164	-0.602766
18	1,400,000 lbs milk 234,000 lbs cream	Two Times Cream Receipts	14,000	5.48470	-0.580673
19	2,300,000 lbs milk 384,000 lbs cream	Two Times Cream Receipts	23,000	5.50333	-0.575007

²⁴ The estimates of α & β are from an equation of the form: $\ln(\text{cost per cwt}) = f(\ln(\text{cwt}))$. To determine the average cost per cwt at some level of daily production, insert the values into an equation of the form: $\text{cost per cwt} = e^{(\alpha + \beta * \ln(\text{daily cwt produced}))}$. The daily cwt should not exceed the maximum daily capacity of the plant shown in the table.

²⁵ Models 6-7 and 10-15 are not included in these estimates. Plants 6 and 7 are inappropriate as they are butter only plants. Plants 10-15, which produce Blends & Condensed milk, have highly collinear estimates with butter and NDM values and bias the results for short-run average cost curves.

Table 21. Regression Estimates of Daily Total Costs with Several Factors of Production.

Plant	α	Butter	NDM	Cost of Capital	Average Wage	\$ per Therm of Gas	\$ per kwh of Electricity	\$ per 1000 gal. Water/Sewer
1	-2356	0.031175	0.078559	22575	393	1134	13572	98
2	-3027	0.024488	0.059351	27239	400	2099	17454	260
3	-3039	0.023551	0.052165	32383	388	2703	17680	326
4	-3435	0.020540	0.049891	39987	407	3050	24759	400
5	-3619	0.020415	0.046422	45446	406	3305	28318	418
6	-206	0.083103	NA	9771	148	259	7325	14.8
7	32	0.067778	NA	11389	146	367	6554	—

\$

The base plants are used to determine the sensitivity of total costs to changes in various factors of production. Total costs may be estimated by inserting appropriate values. For example, if plant 3 processes 20,000 pounds of butter and 40,000 pounds of NDM daily, and has; a cost of capital equal to 0.07, an average wage of \$8.50, \$/therm of \$0.42, \$/kwh of \$0.08, and \$/1000 gallons equal to \$2.00 then proceed as follows:

$$\text{Total cost} = (-3039) + (0.023551 * 20000) + (0.052165 * 40000) + (32383 * 0.07) + (388 * 8.50) + (2703 * 0.42) + (17680 * 0.08) + (326 * 2.00)$$

$$\text{Total cost} = -3039 + 471.02 + 2086.60 + 2266.81 + 3298 + 1135.26 + 1414.4 + 652$$

$$\text{Total cost} = \$8,285$$

Other Agricultural Economics Research Publications

- | | | |
|-----------|---|--|
| No. 89-20 | Wages and Benefits of Full-Time Non Family Employees on Larger Than Average New York Dairy Farms | Thomas Maloney
Sue Woodruff |
| No. 89-21 | Chapter 12 Farm Bankruptcy in New York State | Raymond J. Barnes
John R. Brake |
| No. 89-22 | The Economic Implications of the U.S. Generic Dairy Advertising Program: An Industry Model Approach | Donald J. Liu
Harry M. Kaiser
Olan D. Forker
Timothy D. Mount |
| No. 89-23 | Operating Results for Dairy Farms Classified by Size, FCRS Data, United States, 1987 | B. Stanton
D. Bertelsen |
| No. 89-24 | Foreign Assistance and Domestic Financial Markets in the Developing Countries | Claudio Gonzalez-Vega |
| No. 89-25 | Incorporating Price Expectations in the Development of a Processor Level Econometric Model of the U.S. Honey Industry for Policy Analysis | Mary K. Smargiassi
Lois Schertz Willett |
| No. 89-26 | Annotated Bibliography of Generic Commodity Promotion Research | Susan Hurst
Olan Forker |
| No. 90-1 | Quarterly Northeast Farmland Values, 1985 Through 1989 | Loren W. Tauer |
| No. 90-2 | A User's Guide to NEMPIS: National Economic Milk Policy Impact Simulator | Harry M. Kaiser |
| No. 90-3 | 1990 Budget Guide, Estimated Prices for Crop Operating Inputs and Capital Investment Items | Darwin P. Snyder |
| No. 90-4 | Whey Powder and Whey Protein Concentrate Production Technology Costs and Profitability | Susan Hurst
Richard Aplin
David Barbano |
| No. 90-5 | Potential Effect of Decoupling on the U.S. Rice Industry | Satoko Watanabe
B. F. Stanton
Lois S. Willett |

