



AgEcon SEARCH
RESEARCH IN AGRICULTURAL & APPLIED ECONOMICS

The World's Largest Open Access Agricultural & Applied Economics Digital Library

This document is discoverable and free to researchers across the globe due to the work of AgEcon Search.

Help ensure our sustainability.

Give to AgEcon Search

AgEcon Search
<http://ageconsearch.umn.edu>
aesearch@umn.edu

*Papers downloaded from **AgEcon Search** may be used for non-commercial purposes and personal study only. No other use, including posting to another Internet site, is permitted without permission from the copyright owner (not AgEcon Search), or as allowed under the provisions of Fair Use, U.S. Copyright Act, Title 17 U.S.C.*

TB 1442 (1972)

USDA TECHNICAL BULLETINS

UPDATA

AN AUTOMATIC MOISTURE CONTROL FOR CONTINUOUS GRAIN DRYERS

ZACHARIAH, G. L.

1 OF 1

START

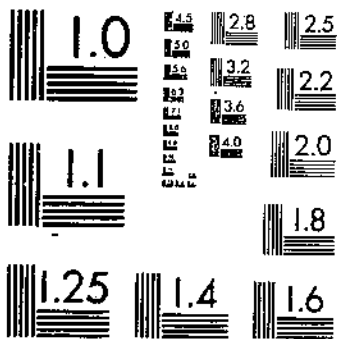

MICROCOPY RESOLUTION TEST CHART
NATIONAL BUREAU OF STANDARDS-1963-A

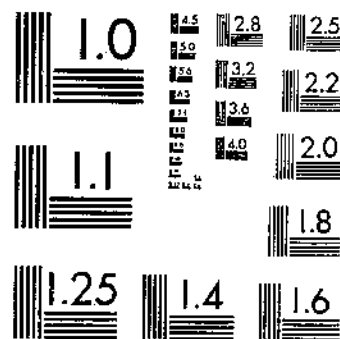

MICROCOPY RESOLUTION TEST CHART
NATIONAL BUREAU OF STANDARDS-1963-A

TK 630
USF-1
100-100

REFERENCE
DO NOT LOAN

An Automatic Moisture Control for Continuous Grain Dryers

DEPT. OF AGRICULTURE

FEB 9 1972

U.S. GOVERNMENT PRINTING OFFICE

Technical Bulletin No. 1442

Agricultural Research Service
UNITED STATES DEPARTMENT OF AGRICULTURE
in cooperation with
Purdue University Agricultural Experiment Station

PREFACE

This bulletin covers the results of research conducted to determine the functional requirements of, and provide a basis for, the design and development of an automatic control system for regulating the flow of grain through continuous-flow dryers to accomplish more uniform drying, reduce labor requirements, and minimize drying costs.

The research and development work was conducted by Purdue University at Lafayette, Ind., under Research Contract No. 12-25-010-856 administered by the Transportation and Facilities Research Division, Agricultural Research Service, U.S. Department of Agriculture. The work was done under the supervision of G. W. Isaacs, project leader, and G. L. Zachariah, project engineer.

The preliminary phases of the research included evaluation of prior developments in controls, consideration of new control techniques, and review of data from the Agricultural Research Service experimental dryer at Purdue University. This was followed by the selection and design of a control system, simulation of the drying process and control system by use of computer models, and construction and performance testing of the prototype on a full-scale continuous-flow dryer.

A detailed report of the simulation studies was published by Zachariah and Isaacs.¹ This bulletin is a condensation of the final report on the contract. It is based in part on a 1963 Ph. D. thesis by Zachariah.

¹ZACHARIAH, G. L., and ISAACS, G. W. SIMULATION OF A MOISTURE CONTROL SYSTEM FOR A CONTINUOUS-FLOW DRYER. Amer. Soc. Agr. Engin. Trans. 9: 297-302. 1966.

CONTENTS

| | Page |
|---|------|
| Summary | 1 |
| Introduction | 2 |
| Review of literature | 3 |
| Design considerations | 7 |
| Moisture sensing elements | 8 |
| Controller | 11 |
| Final control elements | 12 |
| Location of sensing points | 14 |
| Description of prototype control system | 14 |
| Sampling and sensing equipment | 15 |
| Control equipment | 17 |
| Final drive | 22 |
| List of equipment | 23 |
| Description of dryers used in performance tests | 24 |
| Full-scale dryer | 24 |
| Laboratory dryer | 25 |
| Performance tests | 26 |
| Full-scale dryer | 26 |
| Laboratory dryer | 39 |
| Performance evaluation and conclusions | 39 |
| Alternate control methods | 45 |
| Controller | 45 |
| Moisture measurement | 46 |
| Computer simulation | 47 |
| Selected references | 48 |

Trade names and names of commercial organizations are used in this publication solely for the purpose of providing specific information. Mention of a trade name or manufacturer does not constitute a guarantee or warranty of the product by the U.S. Department of Agriculture or an endorsement of the Department over other products not mentioned.

Washington, D.C.

Issued January 1972

For sale by the Superintendent of Documents, U.S. Government Printing Office
Washington, D.C. 20402 - Price 30 cents
Stock Number 0100-1444

An Automatic Moisture Control for Continuous Grain Dryers

By G. L. ZACHARIAH, *professor*, and G. W. ISAACS, *professor and head of Department of Agricultural Engineering, Purdue University*; G. H. FOSTER, *investigations leader*, and L. E. HOLMAN, *former investigations leader, Transportation and Facilities Research Division, Agricultural Research Service*

SUMMARY

The accurate and automatic measurement of moisture content was found to be the most critical factor in the automatic control of a grain dryer. Several moisture measuring methods were investigated to compare their accuracy under idealized conditions. The effect of recent drying of the grain on the operation of moisture meters was also investigated. All meters studied were affected to some degree, but the dielectric methods were most suitable for overcoming the effect of recent drying.

Field tests of representative models of the common types of continuous-flow dryers showed that nonuniform drying frequently occurs. Grain was found to flow at different rates in different parts of the dryer, resulting in grain being discharged at different moisture contents. From a control standpoint, the importance of nonuniformity lies in determining the sampling point. Under the worst condition of nonuniformity it was found that three sampling points per column were adequate to obtain a representative sample.

A laboratory model of a column-type continuous-flow grain dryer was constructed to evaluate the dynamic drying characteristics of a typical dryer. This dryer also was used to investigate optimum moisture sensing points and the relationship between exhaust air temperature, grain moisture content, and other drying variables. The operational data were utilized to develop mathematical equations describing the dryer operation. Computer simulation of the drying process and of proposed control systems was used to determine the optimum control system.

A final prototype control system was developed using a modified dielectric moisture meter as the moisture sensor and a control unit with proportional, reset, and rate modes. This system was tested on a full-scale continuous-flow dryer. Preliminary tests

showed that the rate mode of control was not effective under the step changes that occur with periodic sampling. The proportional and reset modes were subsequently employed to accomplish the desired control action.

The control was evaluated in a series of drying tests with constant initial moisture conditions and with drying air temperatures of 140°, 190°, and 240° F. Additional tests determined the response of the control system to step changes in initial grain moisture of from 30 to 20 percent and back to 30 percent. Similar step sequences using 20 and 25 percent initial moistures were also used. These test conditions were much more severe than those prevailing under normal dryer operation.

The sampling and moisture sensing equipment functioned very well. The primary shortcoming apparent in the test of the system was the erratic reset rate produced by the controller at the low settings required for dryer control. The long process time lag introduced a need for a much lower reset rate than is normally required of such controllers in other applications. Modification of the newer transistorized controllers appeared to offer a solution to the reset problem.

INTRODUCTION

Improved plant varieties, modern machines, and new farming practices have resulted in increased quantities of damp grain reaching market points. Most of this grain must be dried before it is acceptable for storage or processing.

Heated air drying provides a practical means for drying wet grain at a high rate, but close control of the final moisture content is essential. Insufficient drying results in grain unsafe for storage, and overdrying generally results in a monetary loss under present grain pricing practices.

In most drying operations an attendant determines the grain moisture levels and attempts to control manually the desired final moisture content. Accurate control requires more persistent attention that is generally possible. Automatic control can be more accurate and dependable and reduce the labor required to operate a dryer.

Control of the grain drying process has several unique features. The most noteworthy of these is the much longer time lag as compared to more typical process control applications. A 2-hour process time, excluding the cooling phase, is common in grain drying. With a feedback dryer control system, there is a comparable lag between the time a change in initial moisture content is in-

troduced and the time that an error is reflected at the control sensing point.

The determination of moisture content for control purposes introduces an unusual requirement for an accurate, reliable, and rapid detector. The sensing device must also be automatic and preferably continuous.

The principal objective of the research reported here was to design an automatic control system specifically for use on a continuous-flow tower-type grain dryer. The system controls the rate at which grain with a variable initial moisture content moves through the dryer to provide dried grain with a constant moisture content. Accuracy, sources of error, and economic considerations were factors evaluated in the development of the system. Other factors considered included the following:

(1) The range of grain moisture and drying conditions over which the control system would effectively operate.

(2) The effect of interaction of variable grain moisture and ambient drying conditions on control action.

(3) The effectiveness of the system in maintaining a constant final grain moisture when installed on continuous-flow dryers operated under Corn Belt conditions.

(4) The applicability of the control system to existing commercial dryers used in the Corn Belt and the need to modify any elements of the dryer.

(5) The functions and responsibilities of operators of dryers equipped with the control system.

Numerous other factors became important in determining the best approach for achieving the research objectives. For example, it was not feasible under the research contract to design, develop, and fabricate the sensing instruments and controller needed for the control system. Therefore, commercially available components were utilized wherever possible without unduly compromising the performance of the system.

REVIEW OF LITERATURE

Control system engineering is well established, and both the theory and practice are extensively described in the literature. The application of automatic control to any new system or process normally involves the solution of problems introduced by special requirements. Although the basic control principles are the same, measurement of the controlled variable and reaction times are frequently different. Development of sensors and the establishment of appropriate controller settings are required. For most

processes there is an optimum operating point so far as productivity, cost, product quality, and safety are concerned. The analytical determination of control settings or the optimum operating point is difficult and time consuming because of the problems involved in setting up a model of the process.

The basic characteristic of an automatic controller is the manner in which it acts to restore the controlled variable to the desired value, and this is defined as the mode of control. Considerable experience is required to select the mode or modes of control best suited to a process. More than one mode is commonly employed in a controller and the effectiveness of each mode must be determined. The principal characteristics of the process associated with the various modes as presented by Honeywell (18)² are given in table 1.

Some direct moisture measuring methods are the most accurate known for measuring moisture content. However, these methods are slow and require mechanical operations that would be difficult to automate. The rapid indirect methods appear to be the most adaptable to automatic control systems.

The electrical meters are the most common of the indirect methods. These meters introduce a sample of grain into an electrical circuit and a measurement is made based on the resistance or dielectric constant or both of the grain.

The literature available on moisture meters disclosed only limited information on the use of electrical instruments for determining the moisture content of grain with nonuniform mois-

² Italic numbers in parentheses refer to Selected References, p. 48.

TABLE 1.—*Characteristics of various modes of control*

| Mode of control | Process reaction rate | Transfer lag or dead time | Process load changes |
|--|-----------------------|---------------------------|-----------------------|
| Two position | Slow | Slight | Small and slow. |
| Proportional | Slow or moderate. | Small or moderate. | Small. |
| Proportional plus rate action | do | Unlimited | Do. |
| Proportional plus reset | Unlimited | Small or moderate. | Slow, but any amount. |
| Proportional plus reset plus rate action | do | Unlimited | Unlimited. |

ture distribution within the kernel. Most of the work reported was of a testing nature to compare the accuracy of various methods under idealized conditions. Many investigators acknowledged that unequal moisture distribution does affect accuracy.

Hlynka and Robinson (9) reported that even the best meter may overestimate or underestimate moisture content by as much as 1 percent. They stated that all electric meters for which grain is not ground are affected by the distribution of moisture within the kernel. Accordingly meters will give erroneous results for grain that has been recently dried. Measurements on all electric meters are affected by grain temperature.

The resistance of grain is a function of the moisture content. Cook et al. (4) reported the results of tests on four commercial resistance-type meters for grain. These meters showed a linear relationship between the logarithm of the resistance of wheat and the moisture content in the range of 11 to 17 percent moisture content. Above 17 percent, the relationship was as follows:

$$\text{Moisture content} = A - B (\log R) + C (\log R)^2$$

Where

A , B , and C = constants

R = electrical resistance

According to Hall (8), grain recently dried with heated air gives lower readings on resistance-type meters than the actual moisture content of the product. This occurs because the resistance, as measured by these meters, is greatly affected by surface conditions.

Isaacs³ reported that a resistance meter using pin-type electrodes was not very accurate in testing whole shelled corn. The standard error of estimate was 1.96 moisture percentage points on recently harvested grain. He indicated that the lack of reproducibility was probably due to variations in the area of contact between electrodes and the corn.

The literature also included several rapid moisture measuring methods not commonly used for grain moisture determination. These included the nuclear magnetic resonance and neutron scattering methods.

Shaw and O'Meara (16) stated that the use of nuclear magnetic resonance measurement of moisture resulted from an attempt to

³ ISAACS, G. W. THE DESIGN OF SIMPLIFIED EQUIPMENT FOR THE RAPID DETERMINATION OF MOISTURE CONTENT OF GRAIN AND FORAGE CROPS. 1954. [Unpublished Ph. D. thesis. Copy on file Mich. State Univ., East Lansing.]

provide an accurate, nondestructive method for the rapid determination of moisture. They reported that detailed studies with a number of materials covering a wide range of moisture contents indicated that nuclear magnetic resonance techniques provide a basis for rapid, nondestructive methods for the routine measurement of moisture.

Although nuclear magnetic resonance appears to provide a relatively accurate and rapid method of determining moisture content, the equipment for making the measurement is complex and expensive. Cost figures are not readily available, but costs are estimated to exceed those of the total dryer. Also, the equipment is large and the sample is small.

At the time of the investigation, neutron scattering instruments were being used successfully for soil moisture measurement. The development of equipment suitable for grain moisture measurement did not appear imminent. However, neutron scattering instruments have since become available and should be considered as possible sensors for a dryer control system.

The radio-frequency power-absorption method measures the power absorbed in the grain as determined by the radio-frequency resistance and dielectric hysteresis of the material. Miller and Jones (12) stated that an advantage of a radio-frequency moisture meter becomes apparent when there are large moisture gradients in the particles of the material due to fast drying. With the rapidly alternating polarizations of the water molecules and consequent energy absorption of a radio-frequency meter, the water cannot "hide" from the meter regardless of how it is distributed throughout the particles.

The National Institute of Agricultural Engineering (14) reported the results of studies where surface-dry grain was produced by drying wheat with an initial moisture content of 21 percent with air at 150° F. and a velocity of 50 f.p.m. Moisture readings were started immediately after drying for 23 minutes and cooling for 13 minutes. The high frequency impedance, low frequency impedance, and electrical conductance methods of moisture determination were investigated. The pertinent results are shown in figure 1.

Matthews (11) described the development of apparatus for automatically controlling the moisture content of the output of a continuous-flow dryer by adjusting the grain throughput rate in response to the signal from a capacitance-type moisture monitor. Experimental work to determine the relationship between permittivity and grain moisture content and temperature was

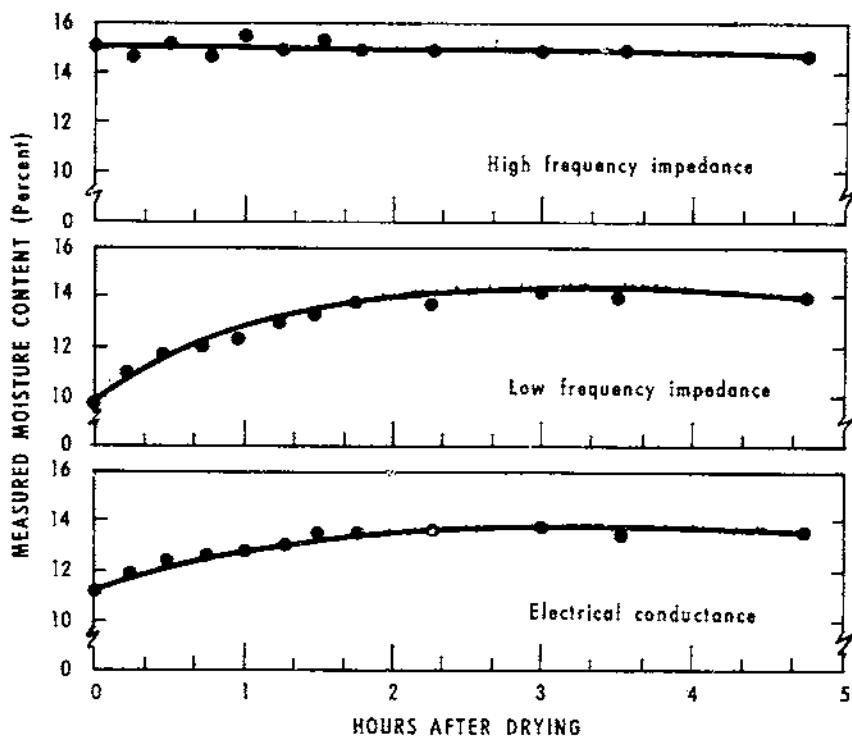

FIGURE 1.—Comparison of moisture contents of wheat measured at intervals after drying by three methods. (Natl. Inst. Agr. Engin. 14.)

reported. Matthews stated that on an experimental scale the performance of the relatively simple prototype control was satisfactory and that proportional control action with automatic reset was suitable for the long process times involved.

DESIGN CONSIDERATIONS

The automatic control system for continuous-flow grain dryers was considered to consist of three general components—the moisture sensing element, the controller, and the final control element. A block diagram illustrating these control system elements incorporated in a complete feedback control system is presented in figure 2.

In the dryer control system the sensing element must measure some condition that is indicative of the moisture content of the grain and present this information in the form of an appropriate signal to the controller. The controller must make decisions

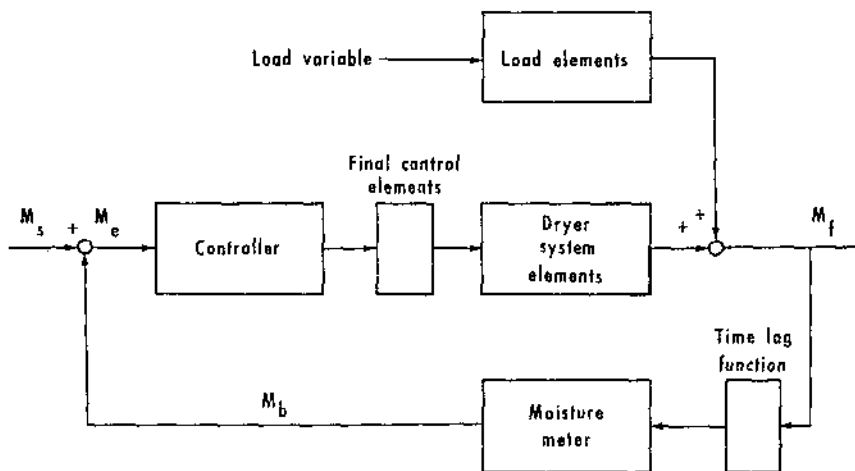

M_s = Set point moisture
 M_f = Final grain moisture
 M_b = Moisture indicated by meter
 M_e = Moisture error

FIGURE 2.—Block diagram of automatic grain dryer control system.

regarding the measured parameters and then cause the appropriate control action to be taken. The final control element is actuated by the controller to take the appropriate action on the controlled variable. In the case of a grain dryer, this could be regulation of the speed of the drive unit to control the rate of grain discharge from the dryer.

Moisture Sensing Elements

The following characteristics were considered of primary importance in the selection of a moisture sensing device for the dryer control system: (1) Accuracy, (2) reproducibility, (3) durability, (4) accommodation of any special grain conditions resulting from drying, (5) adaptability to an automatic control system, and (6) cost.

The requirement for rapid measuring equipment that can be connected into an automatic control system eliminates the slow moisture measuring methods. Based on the information available at the time, the rapid methods were ranked according to functional ability independent of cost or adaptability as follows:

| | <i>Relative cost</i> |
|--|----------------------|
| Nuclear magnetic resonance ----- | High. |
| Neutron scattering ----- | Do. |
| Radio-frequency power absorption ----- | Medium. |
| Dielectric ----- | Low. |
| Resistance ----- | Do. |
| Temperature measurement ----- | Very low. |

Temperature measurement and methods of measuring radio-frequency power-absorption, dielectric, and resistance properties were considered the most promising as moisture indicators for use in a control system. Laboratory studies were conducted on these methods to determine their overall operating performance under situations comparable to those in dryer control operations.

The temperature measuring method of control is based on the relationship between grain moisture and the temperature drop in the drying air as it traverses the drying column. The initial moisture content, airflow rate, and drying air temperature also affect the temperature drop, which reduces the effectiveness of this method. The main advantages of the system are its simplicity and low cost. Test results showed the temperature control system has merit as a moisture control aid, but it did not satisfactorily fulfill the requirements for complete control.

Instruments of the radio-frequency power-absorption type were available in two configurations. One used a loose fill of whole grain in the sample container; the other, which was tested, compressed the sample prior to measurement. Test results indicated large variations in meter readings among samples from the same lot of grain. Since the method tested was destructive, repetitive tests with a given sample were not possible. Because of the lack of good reproducibility over a satisfactory range of grain moistures and the difficult mechanical operation, this method was not considered further.

Manufacturers of conventional electrical grain moisture meters were surveyed to obtain information regarding the ability of their meters to measure moisture content of rapidly dried grain. Results of this survey supported the literature review, indicating that little research has been conducted to determine the effect of wide moisture gradients—common in rapidly dried grain—on the accuracy of moisture meters.

On the basis of laboratory tests, the capacitance (dielectric) moisture measuring principle was determined to be the most effective electrical measurement for overcoming errors resulting from recent drying. Moisture readings for two capacitance and

two resistance meters are shown in table 2. The capacitance method has the further advantage over many of the conductance (resistance) type instruments in that it is a nondestructive test. Essentially unlimited quantities of samples may be drawn and later returned to the grain stream.

Extensive tests were conducted with a newer capacitance-type moisture meter having features that appeared to make it adaptable to dryer control systems. The moisture meter was an automatic null balance instrument. A linear scale indicated moisture directly, allowing a potentiometer to be attached to the balancing mechanism to give an output signal that was a direct function of the error in moisture content.

The effect of variations in test weight and packing is reportedly compensated for by a special tapered electrode. The meter had a thermistor located in the test cell to sense the temperature of the sample and compensation was automatic.

TABLE 2.—Comparison of grain moisture readings immediately after and 4 days after drying with 2 capacitance and 2 resistance meters

| Type of meter tested | Drying time | M_0^1 | M_4^2 | $M_0 - M_4$ |
|----------------------|-------------|---------|---------|-------------|
| | Minutes | Percent | Percent | Percent |
| Capacitance 1 | 15----- | 21.3 | 22.4 | -1.1 |
| | 20----- | 19.7 | 19.5 | + .2 |
| | 25----- | 18.3 | 17.7 | + .6 |
| | 30----- | 17.4 | 16.7 | + .7 |
| Capacitance 2 | 15----- | 21.5 | 21.6 | - .1 |
| | 20----- | 19.1 | 19.1 | 0 |
| | 25----- | 17.8 | 17.4 | + .4 |
| | 30----- | 17.1 | 16.0 | +1.1 |
| Resistance 1 | 15----- | 16.0 | 21.9 | -5.9 |
| | 20----- | 13.5 | 19.3 | -5.8 |
| | 25----- | 12.4 | 17.4 | -5.0 |
| | 30----- | 11.5 | 15.9 | -4.4 |
| Resistance 2 | 15----- | 19.4 | 22.5 | -3.1 |
| | 20----- | 16.2 | 20.7 | -4.5 |
| | 25----- | 15.7 | 18.4 | -2.7 |
| | 30----- | 14.4 | 17.9 | -3.5 |

¹ M_0 = moisture content of grain sample as determined by meter immediately after drying and cooling.

² M_4 = moisture content of grain sample as determined by meter 4 days after drying. Sample was stored in sealed container.

Some apparently well-controlled experiments reported by the manufacturer indicated that errors in moisture readings due to recent drying are significantly reduced if (1) dielectric measurements are made at frequencies of 11 megacycles or greater and (2) one of the meter electrodes is insulated to reduce the effect of conductance. This newer capacitance meter included these two design features.

The performance of this meter was investigated for the following characteristics to determine its suitability for use in a dryer moisture control system: (1) Effect of grain with a nonuniform distribution of moisture within the kernel, (2) effect of sample size, (3) reproducibility, and (4) effect of the method of introducing the grain into the test cell.

Controller

Because of the wide variety of controller components commercially available, it appeared unnecessary to design a special controller. Several controllers were investigated in selecting one that would translate the output of the primary sensing element—the moisture meter—into the appropriate control action.

A duration adjusting-type controller with proportional plus reset action was selected for incorporation into the initially proposed control system. The controller regulated the flow of grain by adjusting the percentage of time that the grain metering device operated. The running time was determined by the deviation from the set moisture level and the length of time that this deviation had existed. Regulating the flow in this manner eliminated the need for a variable speed drive and transducer between the controller and the variable speed unit. The controller provided a means for adjusting the frequency of the on-off cycle as well as the proportional band and reset rate.

The controller was tested as a part of a prototype control system installed on a continuous-flow dryer. The duration adjusting-type controller used in the test system had several shortcomings. The most limiting of these were an insufficient range of adjustment and a shift in cycle time when adjustments were made in proportional band or reset rate. Variations in cycle time caused the drive motor to cycle too rapidly, causing the motor to overheat and in other cases to cycle too slowly, thereby resulting in poor control.

Because the operation of the duration adjusting-type controller was not satisfactory for the proposed application, a more versatile controller was selected for the final prototype control system. A

position adjusting-type controller was selected for this purpose. The output of this controller determined the angular position of a rotating shaft. This form of output could be connected to the speed controls of a variable speed drive or could be used to set a percentage timer or any other device that could be regulated by a rotating action. The selected controller had a much wider range of adjustment in reset rate and also a rate control mode.

The position-adjusting controller is discussed later in detail.

Final Control Elements

Since the feed control mechanism of a given dryer is an important factor in the functioning of a dryer control system, 10 manufacturers of continuous-flow dryers were consulted regarding the method of grain throughput control used on these dryers.

Two of these manufacturers used the oscillating pan method of metering grain throughput. The other eight used fluted rolls, augers, or a moving belt. The fluted-roll method, which was the most commonly used, is illustrated in figure 3.

The full-scale continuous-flow dryer used in the investigations was equipped with three oscillating pans to control the flow of

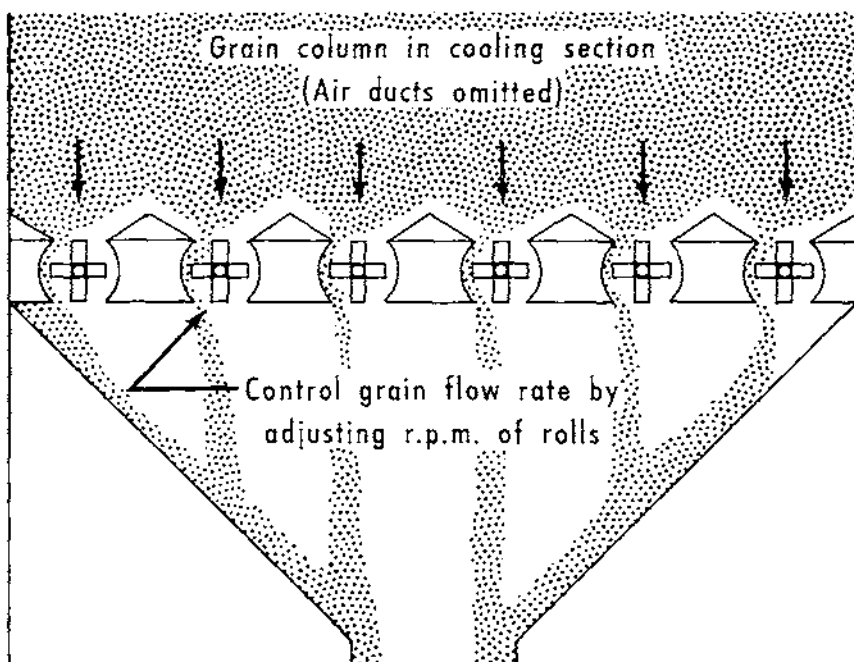

FIGURE 3.—Simplified cross-sectional view of fluted-roll feed-rate control for grain dryer.

grain through the dryer. This continuous-flow device is illustrated in figure 4.

The grain throughput rate could be controlled on all these flow-control devices by regulating the speed of the discharge drive. Numerous variable speed devices were considered for adjusting the grain throughput rate of a dryer in accordance with the output of the controller. Many of these units had an undesirable nonlinear relationship between the control input and the drive output. Although some linear models were available, the relatively high cost and complexity made them unfeasible.

All the dryers investigated, with the possible exception of the belt dryer, could be controlled by cycling the drive on and off. This control technique would allow easy adjustment of the grain flow from zero at the off position to the maximum achieved when operating continuously. A percentage timer provides a ready means for controlling the flow rate between these limits.

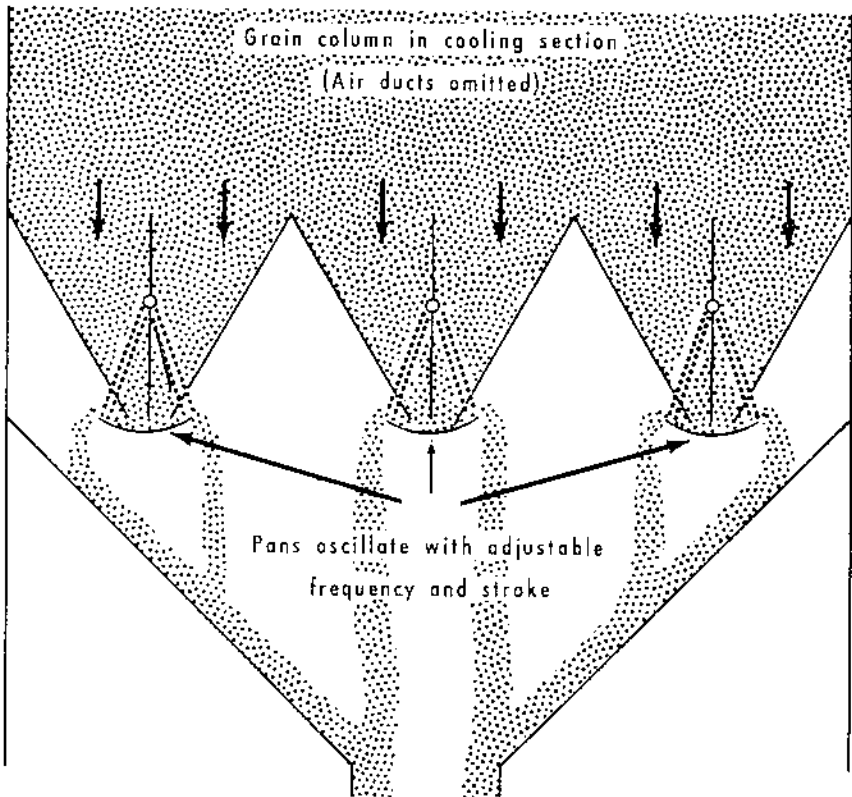

FIGURE 4.—Simplified cross-sectional view of continuous-flow metering device used on test dryer.

Location of Sensing Points

Test data indicated measurable lateral nonuniformity in the moisture content of the dried grain discharged from the heater section of the test dryer. An analysis of the operational data from the dryer indicated that the nonuniform drying resulted from an uneven flow of grain through the dryer, with the grain moving faster near the sides and slower in the center. Critical duct sections in the dryer were modified, and the nonuniformity in the moisture content of the dried grain was reduced to an acceptable level.

The nonuniform drying occurring in the test dryer introduced a question regarding similar conditions existing in other types of continuous-flow dryers. Field tests of representative models of continuous-flow dryers were conducted to determine the extent of nonuniformity in four basic types of dryers. Included in the investigations were six column dryers using a thin layer of grain with no internal ducts—five with parallel ducts located in the grain column and one dryer using a horizontal metal belt for moving grain through the dryer.

These tests indicated that reasonably uniform drying could be accomplished in the continuous-flow dryers. With reasonably uniform flow and temperature conditions, a small number of sensing elements is adequate to monitor the moisture content of grain discharged from a dryer. This acceptability is based on control of average moisture content and no inference regarding uniformity of drying or quality is intended.

The location of sensing points for grain moisture determination is important when considering the response of the dryer to the input of grain at variable moisture levels. From test results the optimum location of a single moisture sensing point was determined to be at the grain discharge from the heater section of the dryer. Since multiple sensing points up and down the dryer would increase the cost and complexity of the system, this approach was not considered feasible.

DESCRIPTION OF PROTOTYPE CONTROL SYSTEM

The control system took a sample periodically from the dryer, measured and compared the moisture content of the sample with the set moisture content, and then adjusted the flow rate of the dryer accordingly. For descriptive purposes the system components were divided into three major groups—the sampling and sensing equipment, the control equipment, and the final drive.

Sampling and Sensing Equipment

The sampling equipment was mounted on the side of the continuous-flow test dryer (fig. 5), and the sampling control equipment was installed in a nearby building. The sampling equipment consisted of (1) sampling augers, (2) cooling chamber, (3) sample divider, (4) automatic scale, and (5) moisture meter.

Sampling Augers

The layout of the sampling augers is shown in figure 6. Three augers of different lengths were used to obtain a representative sample across the width of the dryer.

Cooling Chamber

Figure 7 illustrates the cooling chamber. A thermostat was installed to shut off the cooler fan when the exhaust air from the cooler dropped below 80° F., the calibration temperature of the moisture meter used. A time was set to override the thermostat, and the grain was dumped from the cooler after 5 minutes regardless of its temperature. Two solenoid valves operated gates at the bottom of the cooling chamber to control the movement of the grain sample through the cooling chamber.

Sample Divider

A standard grain divider was installed to receive the grain from the cooling chamber. The divider reduced the cooled sample to slightly more than that needed for the moisture meter, and the remaining grain was returned to the dryer. A bypass valve was installed in the grain duct running from the bottom of the divider to the automatic scale. With this arrangement it was not necessary to run grain through the scale and moisture meter during purging operations. The sampling augers were purged at the start of the sampling cycle to remove all grain from the previous sampling.

Automatic Scale

The control system required a scale capable of automatically weighing and dumping a 250-gram sample of any of the common grains with a desired accuracy of plus or minus 1 gram. The scale is illustrated in figure 8.

Moisture Meter

A capacitance-type moisture meter was automated to sense the moisture content of grain samples provided by the sampling augers and to provide a mechanical output to position a potentiometer.

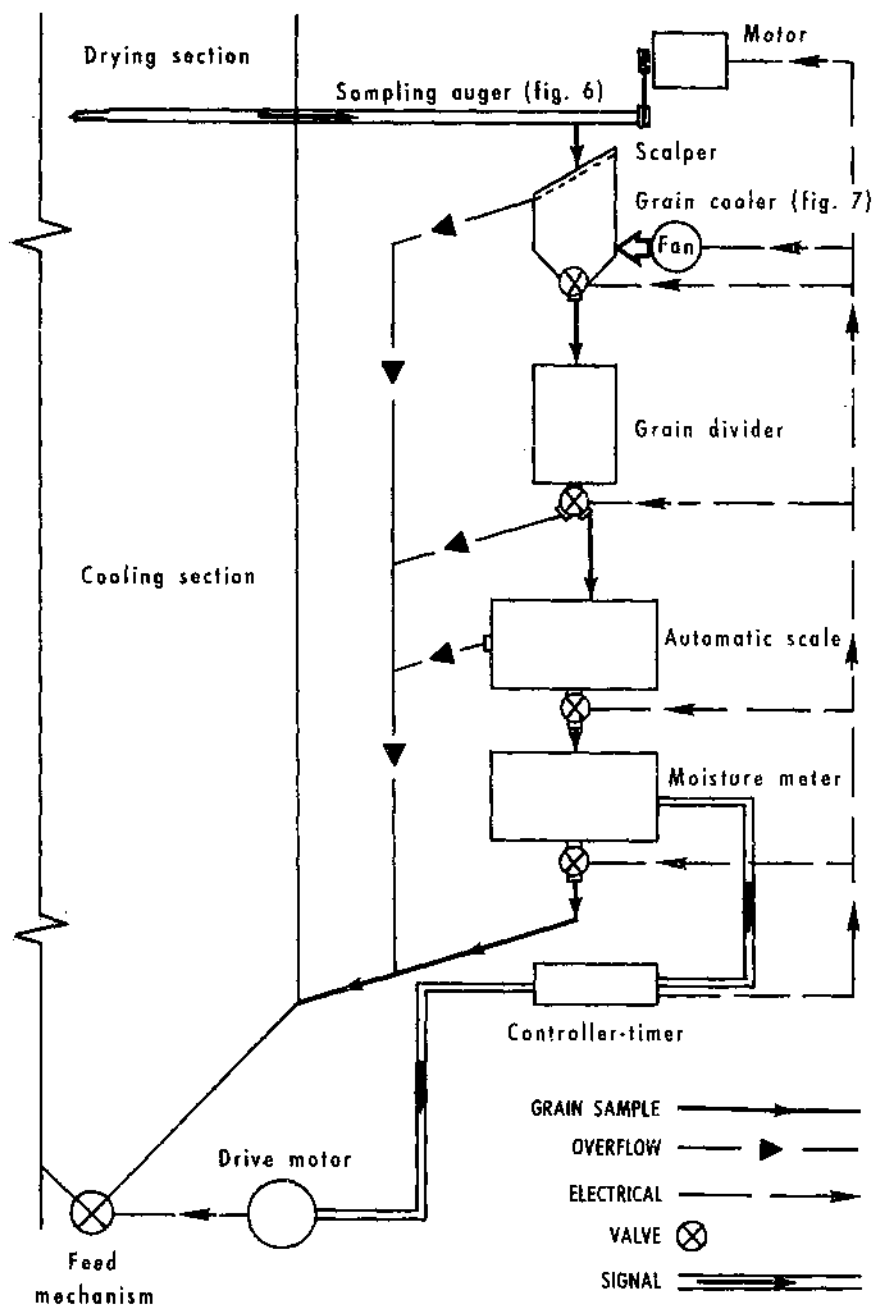

FIGURE 5.—Prototype grain dryer control system.

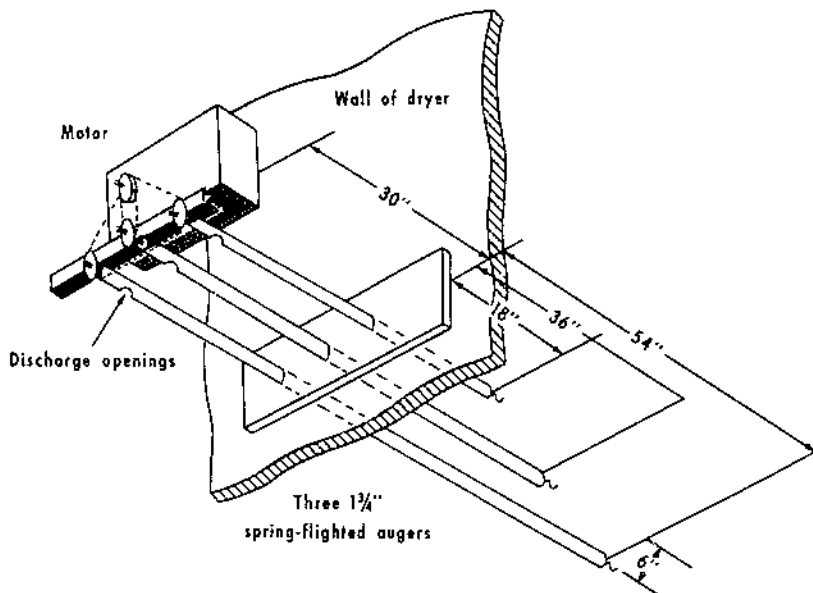

FIGURE 6.—Layout of sampling augers. (See fig. 5 for arrangement in control system.)

meter. The meter accuracy was as good as or better than meters acceptable to the grain trade; i.e., a standard error in the range of plus or minus 0.25 percent moisture content. The meter had a range of approximately 6 to 36 percent moisture, wet basis.

Two solenoids were provided to operate the gates in the meter to load and discharge the sample into and from the test cell. A 1,000-ohm potentiometer was positioned by the automatic balancing mechanism in the meter to provide an error signal to the controller.

The modified moisture meter is illustrated in figure 9.

Control Equipment

Controller

A three mode (proportional plus reset plus rate) controller (fig. 10) was selected to provide the versatility desired for the prototype control system. The controller used the potentiometer connected to the moisture meter to provide the error signal input. The proportional band was adjustable over the range from 10 to 200 percent and the reset rate from one to 10 repeats per hour. The rate mode of control was not used since it was ineffective with

the step changes in measured moisture content resulting from the periodic sampling.

The grain flow rate adjustments were accomplished by controlling a positioning control motor (fig. 11), which in turn positioned the control shaft of a percentage timer.

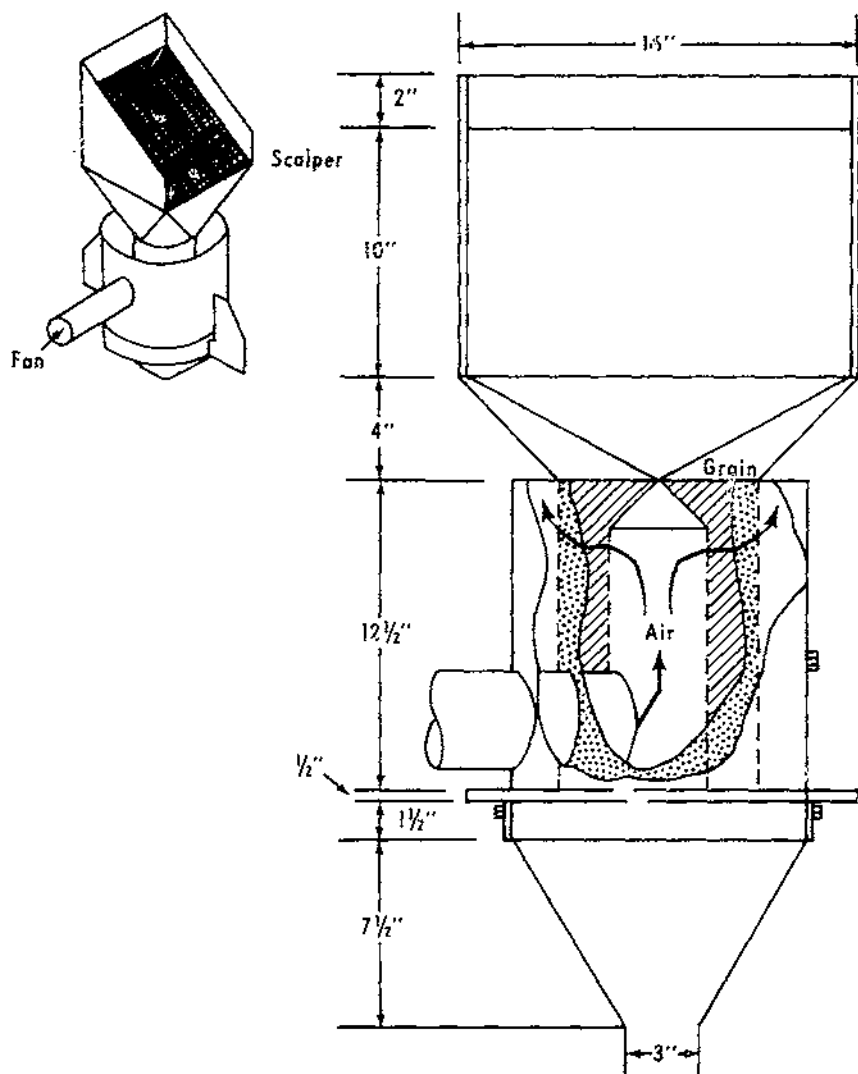
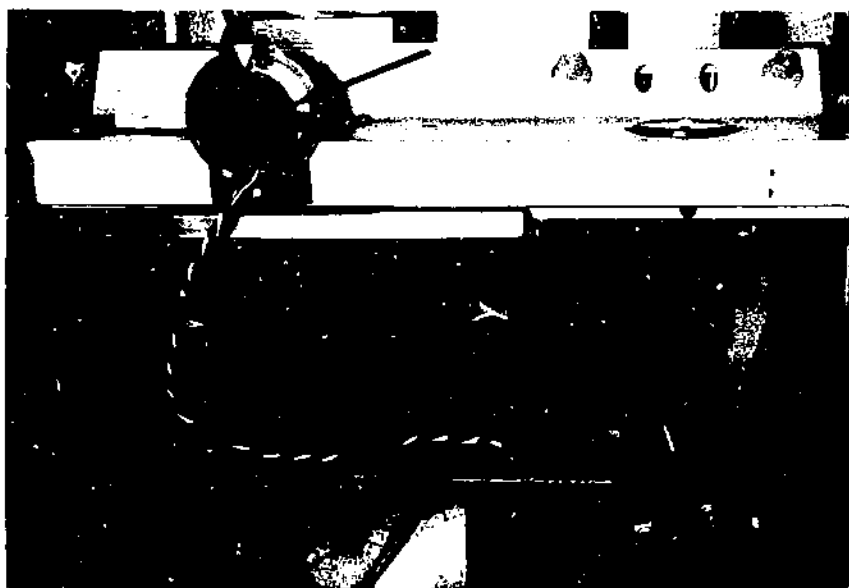

FIGURE 7.—Cooling chamber assembly.



BN-36854

FIGURE 8.—Automatic scale.



BN-36858

FIGURE 9.—Automatic balancing moisture meter as modified. The set point moisture content was established by positioning the potentiometer (arrow).

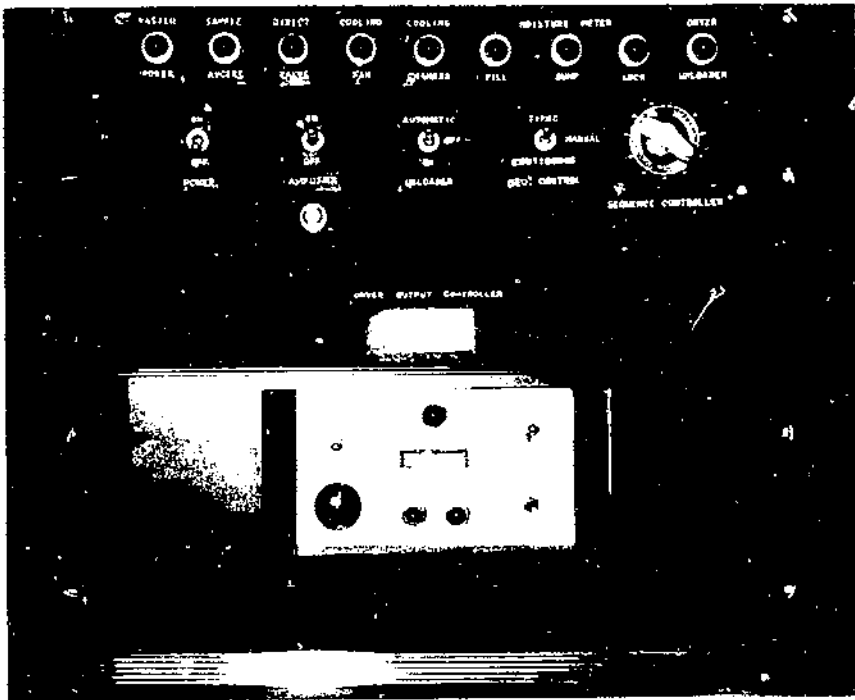

BN-36856

FIGURE 10.—Control console including operating indicator lights (top row), power and sequence switches, and automatic controller (bottom).

Percentage Timer

The timer was a motor-driven switching device used to turn the drive motor of the grain discharge on and off on a time-base principle (fig. 11). The switch contacts in the timer were actuated by a cam driven by a low speed synchronous motor. The cam rider and switch mechanism were connected to and adjusted by the output shaft of the positioning control motor. The timer operated on a cycle, which included one "on" and one "off" period each minute. The timer was calibrated in percent, which was a direct indication of the percentage of the "on" time of the grain discharge motor. The timer setting was continuously adjustable for "on" time from 0 to 100 percent.

A time cycle longer than 1 minute would also be acceptable for turning the grain discharge off and on. No serious reduction in dryer performance would result from a period of 5 minutes, and the longer period would be desirable for grain discharge drive motors, which have a limiting duty cycle (rate at which the motor

can be started and stopped). The 1-minute period was the longest available in common percentage timers with the 0 to 100 percent range of adjustment. Timers with longer periods are readily available with a range of adjustment from 4 to 96 percent "on." The 1-minute period caused no overheating problems in the prototype system.

Sequence Timer

The sequence of sampling and measurement operation was controlled by a timer with a 10-minute cycle, which operated nine individual single-pole double-throw switches (fig. 11). These switches controlled the sequential handling of the sample from the time it was taken until it was discharged from the moisture meter. The individual cam-switch relationship was adjustable to permit closing of switch contacts for any period from 0 to 100 percent of the cycle. The point in the cycle where the switch closed was also adjustable. Table 3 shows the timing cycle and switching sequence of the sampling operation.

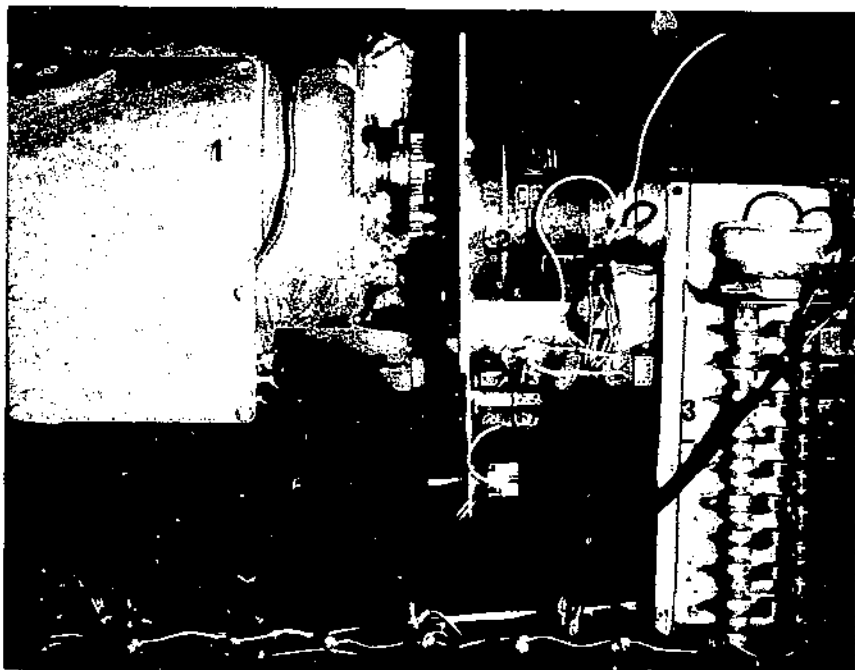

SN-36855

FIGURE 11.—Interior of control console showing positioning motor (1), percentage timer (2), and sequence timer (3).

TABLE 3.—*Timing cycle and switching sequence of sampling and sensing operations*

| Time period | | Switching sequence | | Operation |
|-------------|---------|--------------------|----------|--|
| Minutes | Seconds | Point | Position | |
| 0 | 0 | 1 | On | Sampling augers started to purge augers. |
| 0 | 0 | 2 | On | Bypass valve positioned to bypass grain around scale and moisture meter. |
| 1 | 15 | 1 | Off | End purging of sampling augers. |
| 1 | 25 | 6 | On | Close cooling chamber gates. |
| 1 | 27 | 8 | On | Restart sampling augers to fill cooling chamber. |
| 2 | 12 | 8 | Off | End filling of cooling chamber. |
| 2 | 20 | 3 | On | Cooling blower on. |
| 2 | 55 | 2 | Off | Bypass valve positioned to put sample in scale. |
| 4 | 45 | 7 | On | Purge moisture meter and scale of old sample. |
| 5 | 20 | 7 | Off | End purge of moisture meter and scale. |
| 5 | 40 | 6 | Off | Dump sample from cooling chamber into sample divider. |
| 6 | 30 | 5 | On | Dump weighed sample into test cell. |
| 7 | 0 | 5 | Off | End of filling test cell. |
| 7 | 40 | 4 | On | Moisture meter balancing motor on. |
| 8 | 30 | - | Off | Moisture meter balancing motor off. |
| 10 | 30 | 1 | On | Start new cycle. |

Final Drive

The prototype system utilized the existing grain discharge mechanism on the continuous-flow dryer. The system could be adapted to any dryer of this type with only minor electrical wiring alterations and mechanical changes.

List of Equipment

The following equipment was used in the control system, with a description of the components and the manufacturers and vendors. Comparable equipment is available from a number of suppliers.

| <i>Controller part</i> | <i>Description</i> |
|------------------------------|--|
| Sampling augers ----- | 1¾-inch diameter spring-flighted augers, Chore-Time Equipment, Inc., Milford, Ind. |
| Gearhead motor ----- | ½ hp., 60 r.p.m. output, model 13GCT, Morse "C," flange gearmotor, Morse Chain Co., Chicago, Ill. |
| No. 40 chain and sprocket... | Morse Chain Co., Chicago, Ill. |
| Blower ----- | ⅜ hp., 357 c.f.m. at ½-inch static pressure, 1,725 r.p.m., size 60H, American Blower Co., Columbus, Ohio. |
| Solenoids ----- | 120 v., continuous duty, model 812-101, Controls Company of America, Schiller Park, Ill. |
| Grain divider ----- | No. 291, Boerner modified multiple divider, Seedburo Equipment Co., 618 W. Jackson Blvd., Chicago, Ill. |
| Automatic scale ----- | Type 6130, plastics Weigh-Feeder, The Exact Weight Scale Co., Columbus, Ohio. |
| Moisture meter ----- | Burrows moisture recorder, Burrows Equipment Co., 1316 Sherman Ave., Evanston, Ill. |
| Potentiometer ----- | 1,000 ohm, type 151, IEC precision potentiometers, Allied Electronics, 100 N. Western Ave., Chicago, Ill. |
| Controller ----- | Model 801C3, three-mode Electr-O-Line control unit, Honeywell, Inc., Brown Instrument Div., Philadelphia, Pa. |
| Controller motor ----- | M930A, Actionator motor, Honeywell, Inc., Minneapolis, Minn. |
| Percentage timer ----- | Model 304A07A0CS, manual-set percentage timer, Automatic Timing and Controls, Inc., King of Prussia, Pa. |
| Sequence timer ----- | Type 540, 9-pole, 11-minute cycle, multiple program, cycling timer, Cramer Controls Corp., Centerbrook, Conn. |
| Relays ----- | Type KA14AY, 115 a.c., 3-pole, double-throw, Potter & Brumfield relays, Allied Electronics, 100 N. Western Ave., Chicago, Ill. |
| Bud instrument chassis ---- | Type CR 1727, deluxe cabinet rack, Bud Metal Products, Allied Electronics, 100 N. Western Ave., Chicago, Ill. |

DESCRIPTION OF DRYERS USED IN PERFORMANCE TESTS

Full-Scale Dryer

The full-scale dryer used in the performance tests of the control system was a continuous-flow tower or shaft type with inverted V-shaped air ducts (fig. 12). The ducts, spaced 1 foot apart, were alternately attached to the heated air supply and open to the outside. The dryer had a nominal drying capacity of 200 bushels per hour for a 5 percentage point reduction in moisture. The total holding capacity was about 400 bushels, with about 200 bushels in the heater section.

The heater section included five heated air-intake ducts and six exhaust ducts. The grain traveled about 11 feet in passing through this section, and the retention time in the heater at rated capacity was about 1 hour. To dry 25 percent moisture grain, about 2 hours in the heater section were required.

The rate at which the grain flowed through the dryer, and thus the retention time, was controlled by a metering device similar to that illustrated in figure 4. The flow-through rate was set by

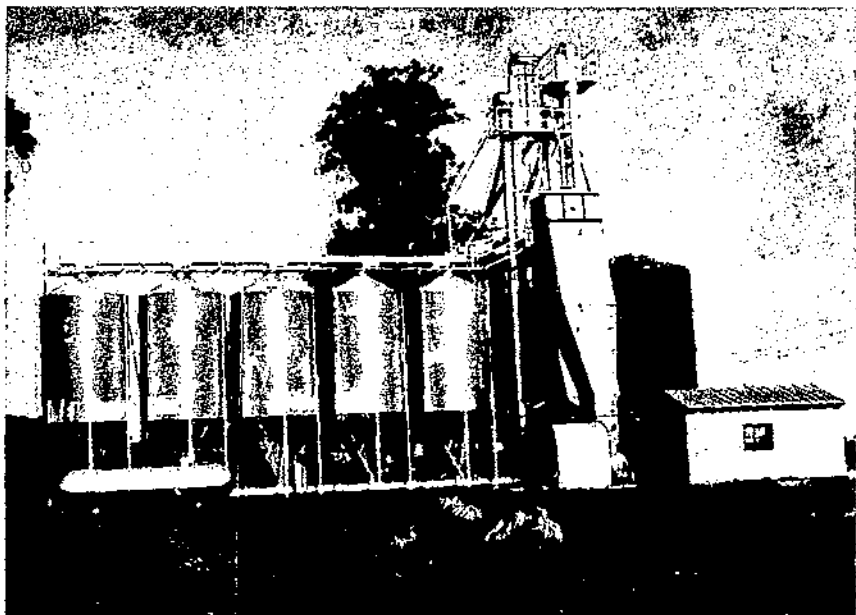

BN-36857

FIGURE 12.—Full-scale dryer and related facilities used in performance tests of moisture control.

a combination of manual adjustments on length and frequency of oscillation of the metering pans.

The drying air could be heated from ambient to temperatures of 100° to 300° F. and was supplied at about 60 c.f.m. per bushel in the dryer section. A system of thermocouples was used to measure air intake, exhaust, and grain temperatures at 54 points. Provision was made to obtain probe samples at six locations as the grain left the heater section of the dryer.

The cooling section of the dryer was similar to, but slightly smaller than, the heater section. A separate fan supplied outdoor air for cooling.

Laboratory Dryer

A laboratory model of a column-type continuous-flow dryer was designed and constructed to evaluate the dynamic drying characteristics of a typical dryer. The dryer also was used for investigating optimum moisture sensing points; for determining the relationship between exhaust air temperature, grain moisture content, and other drying variables; for information on the computer simulation of the drying process; and for preliminary testing of the prototype control system. The dryer, shown in figure 13 with storage bins and related equipment, had a column 8 feet

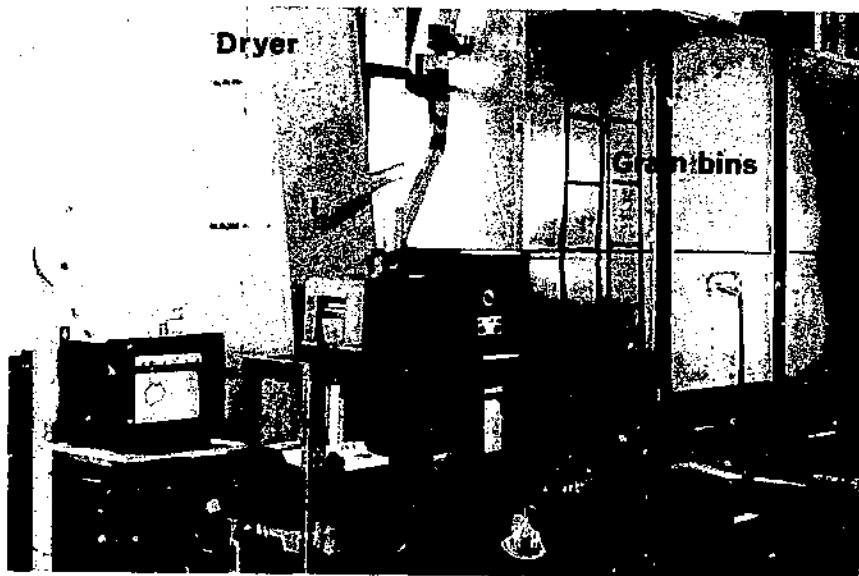

FN-2401

FIGURE 13.—Laboratory dryer and related facilities used to evaluate drying characteristics related to a moisture controller.

high, 6 inches thick, and 18 inches wide. A 6-bushel test lot was sufficient to run a test in this dryer.

The dryer could be operated with airflow rates up to 75 c.f.m. per bushel and temperatures up to 250° F. A specially designed metering device was used with the dryer to provide uniform flow of grain through the column. Air temperatures were measured on the air inlet and exhaust sides of the column. Sampling ports were provided for taking samples from points in the column for intermediate moisture analysis as well as obtaining initial and final moisture values.

PERFORMANCE TESTS

Full-Scale Dryer

The primary objectives of the performance tests were as follows:

- (1) Determine the capacity of the control system to correct for load disturbances in maintaining the desired final moisture content of the dried grain.

- (2) Test the mechanical and electrical functioning of the system hardware.

Changes in initial moisture content of the grain were the only load disturbances introduced as a part of the final test sequence. Three temperature levels were used in the tests, with the temperature held constant throughout each test. This provided for different time lags in the system response, but these changes in temperature were not considered a disturbance. Variations in relative humidity and airflow rate had been considered previously and were found to be of minor importance in evaluating the control system as compared to changes in initial moisture content. The accuracy of the control system in maintaining a constant final moisture with varying input moisture was the foremost consideration.

The schedule for nine tests using the full-scale test dryer is given in table 4.

The controller settings—proportional band and reset rate—had to be established prior to the start of each performance test. The slow response of the dryer and the problems encountered in running extended tests made unfeasible the shortcut methods frequently used in other control applications to establish the settings. A direct analytical approach for determining the set points also was not possible.

The values used in the test sequence were determined by an

TABLE 4.—Description of performance tests with full-scale dryer

| Test ¹ | Amount of grain | Initial moisture | Drying air temperature |
|-------------------|-----------------|------------------|------------------------|
| | Bushels | Percent | ° F. |
| 1----- | 600 | 25 | 240 |
| 2----- | 600 | 25 | 190 |
| 3----- | 600 | 25 | 140 |
| 4----- | 600 | 20 | 240 |
| 5----- | 600 | 20 | 190 |
| 6----- | 600 | 20 | 140 |
| 7----- | 100 | 25 | 190 |
| | 100 | 20 | |
| | 100 | 25 | |
| | 100 | 20 | |
| | 100 | 25 | |
| 8----- | 200 | 25 | 190 |
| | 300 | 20 | |
| | 200 | 25 | |
| 9----- | 200 | 30 | 190 |
| | 300 | 20 | |
| | 200 | 30 | |

¹ In tests 7, 8, and 9, grain was introduced in listed sequence.

approximation method developed by the investigators. A step change from 20 to 25 percent in initial moisture content of the grain was considered as the basis. With no change in drying time, this would be reflected at the dryer discharge as an error of approximately four moisture percentage points.

For a starting point the proportional band was established so that the response to the four percentage-point error would adjust the drying rate to the level that would dry 25 percent grain to the set moisture level. This required a change in flow rate through the dryer of approximately 30 bushels per hour or 15 percent of the total range of adjustment. This established the proportional constant (K_c)⁴ relating error and grain flow rate at approximately 8 bushels per hour per moisture percentage point. The relationship can also be converted into the more common terms of instrument proportional band. When considering the range of the

⁴ K_c = change of manipulated variable caused by a unit change in deviation. As applied to the dryer control system, it is the change in grain discharge rate per unit change in moisture (bushels per hour per moisture percentage point).

moisture meter in moisture percentage points and the percent of the slide-wire used in covering this range, the proportional band was approximately 100 percent.

The proportional constant, as defined, provided a more straightforward relationship between the grain flow rate and error, and it is used in lieu of proportional band to describe system response in this bulletin. The reset rate was established to maintain the grain flow rate at the new level (following the error due to a step change) by offsetting the proportional action. This action functioned to maintain the flow rate at the required level as the error was reduced. The reset time constant, T_r , which is the time required for the reset action to equal the proportional action with a given error, was determined to be 0.85 hour. The reset rate (repeats per unit time) is the inverse of T_r .

Operational data recorded during performance tests included initial and final sample moistures and inlet and exhaust air temperatures, each taken at 20-minute intervals. The moisture content sensed by the control system and the grain flow rate measured by a 6-bushel automatic scale were recorded continuously.

A statistical analysis of the moisture content data was made to determine the mean, the mean deviation, and the standard deviation of the moisture contents for each test.

The dryer discharge rate was normalized by dividing the grain discharge rate by the bushel capacity of the dryer heater section. This was done to facilitate comparisons between the two dryers used in the investigation and to make the data readily applicable to dryers of other sizes. To convert the relative flow rate to actual discharge rate for the full-scale dryer, the relative value is multiplied by 200 bushels. For the laboratory dryer, the multiplier is 4.8 bushels. The use of the relative flow rate is particularly important in applying the proportional constant to drying systems with volumes other than those used in this investigation. The proportional constant for a particular dryer would be determined by multiplying the recommended value by the bushel volume of the dryer heater section.

The results of the nine performance tests in the full-scale dryer are plotted in figure 14. Each graph presents the relative grain flow rate and moisture data versus grain layer number. A grain layer consisted of 6 bushels of grain as weighed from the dryer by the automatic dump scale. The layers were numbered consecutively as they passed through the dryer.

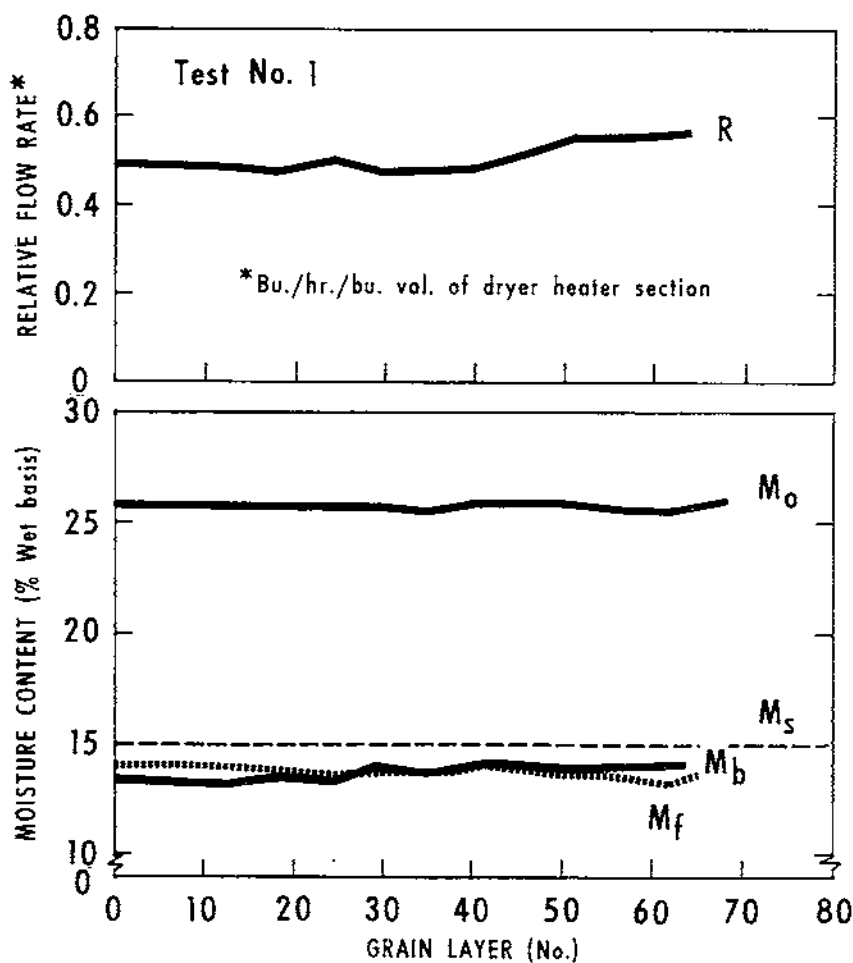
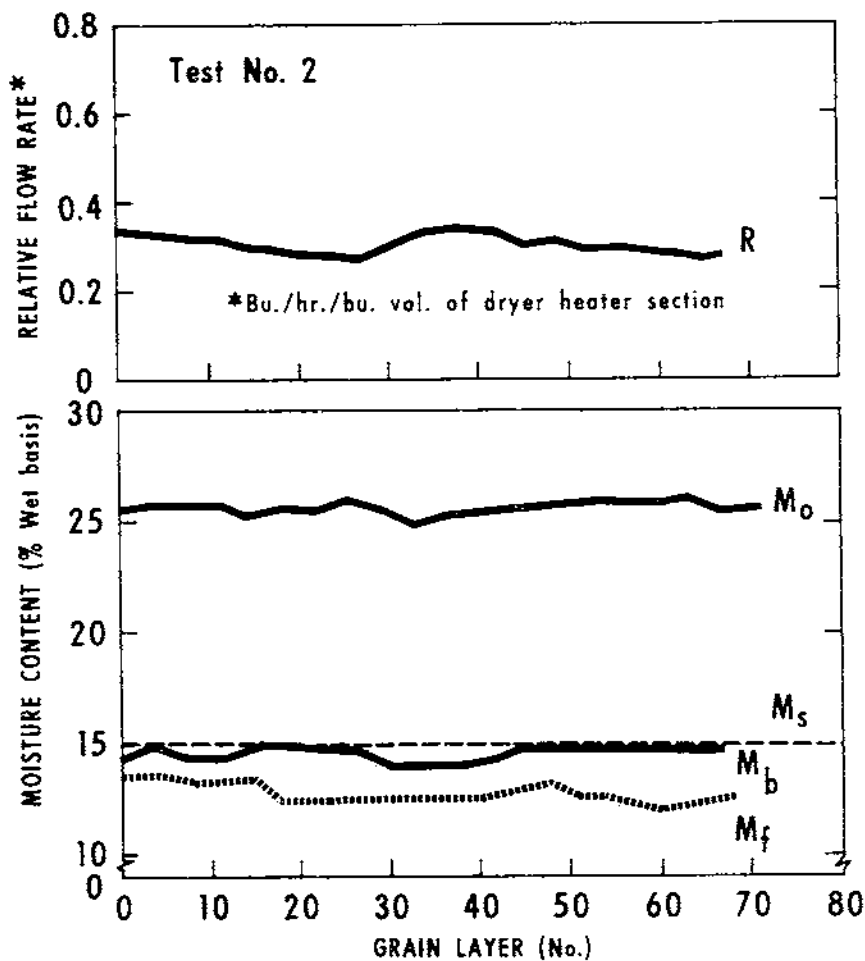
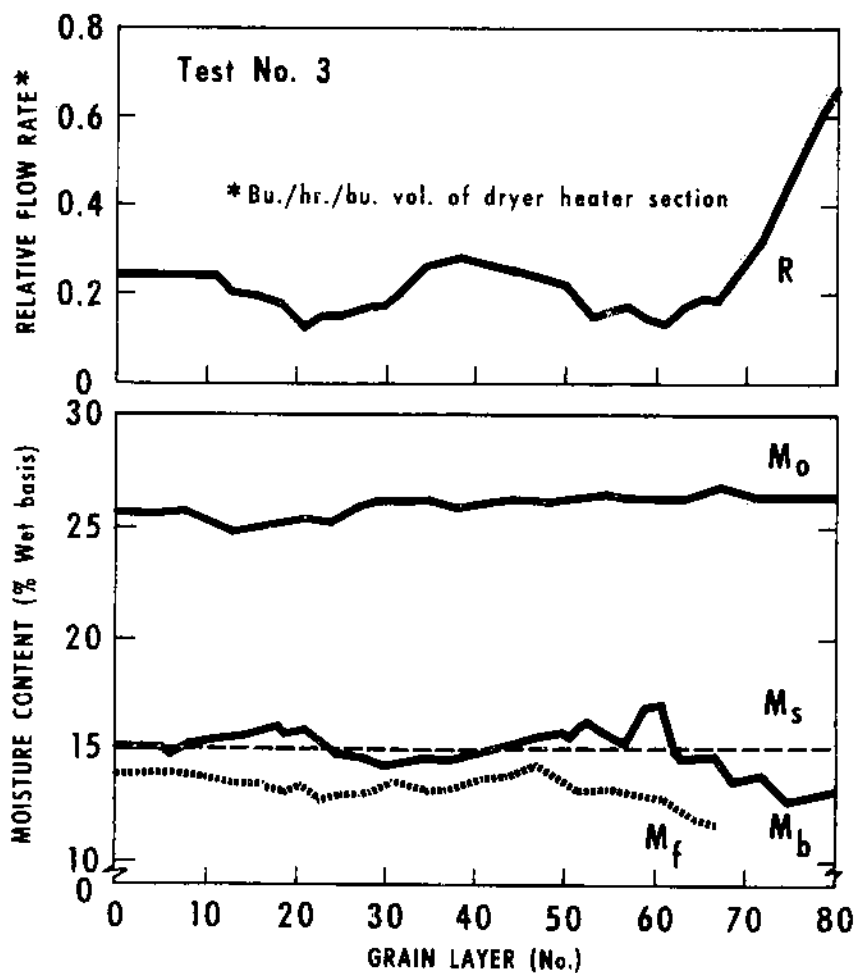
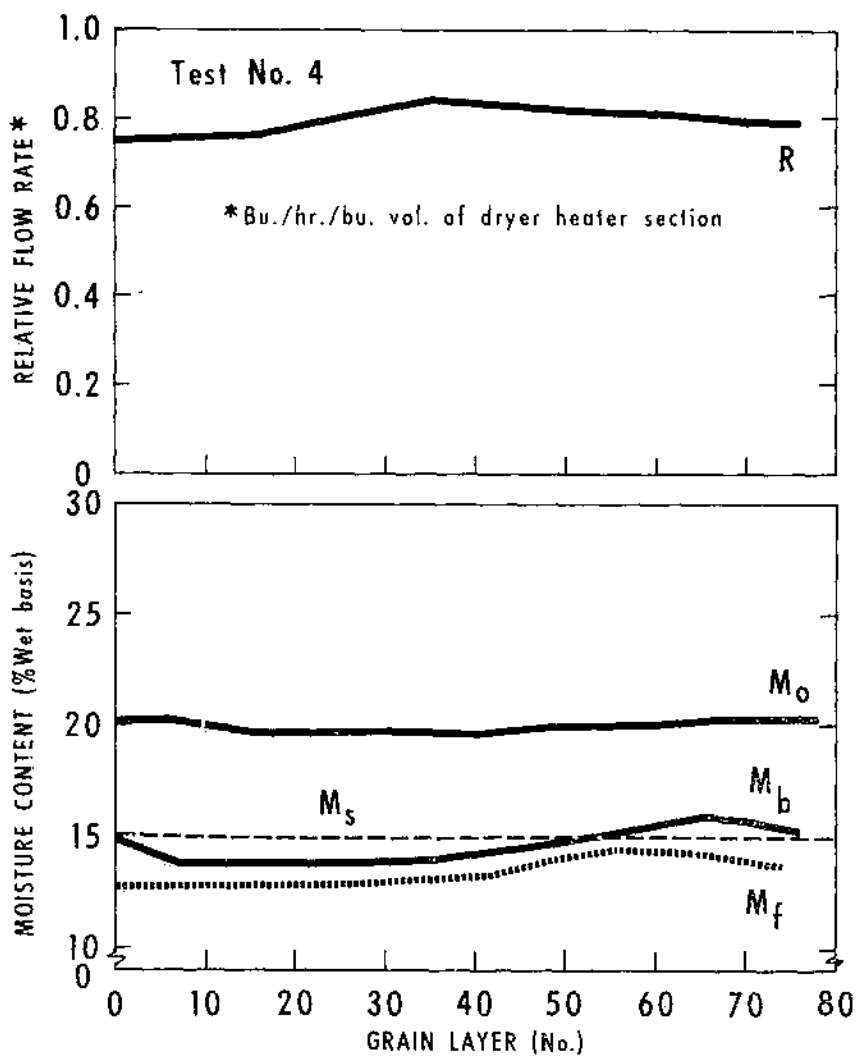
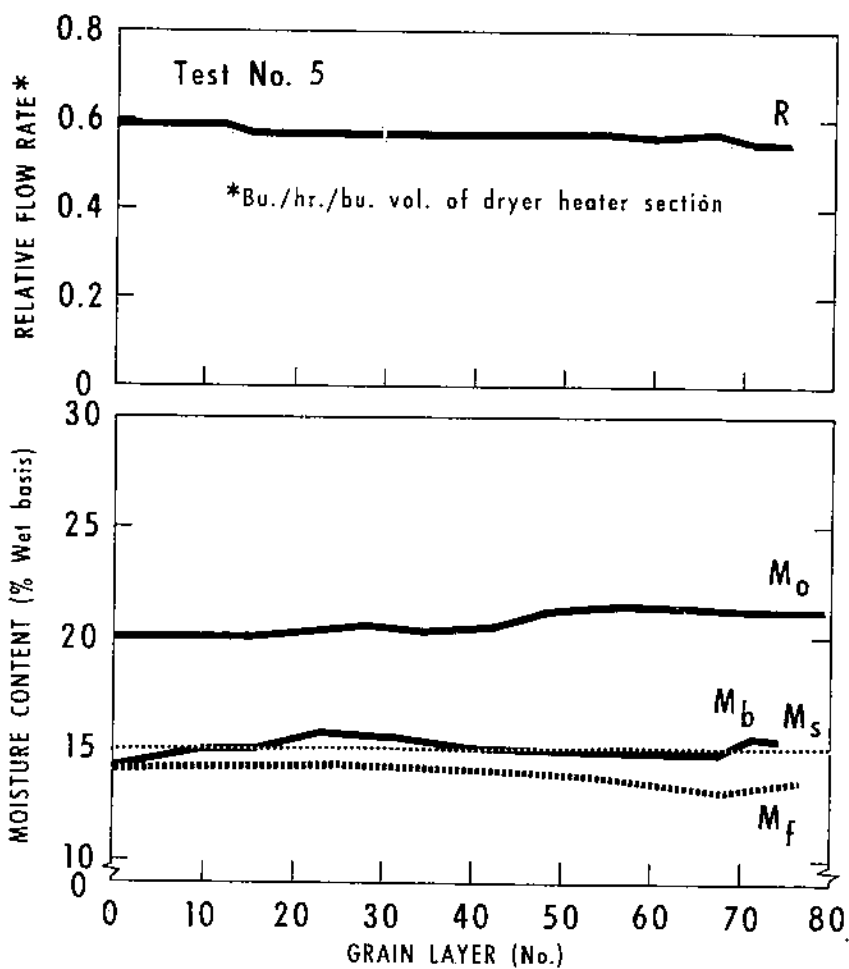

FIGURE 14.—Relative grain flow rate and moisture data versus grain layer number for performance tests 1 through 9 with full-scale dryer. (For explanation of symbols, see p. 38.)









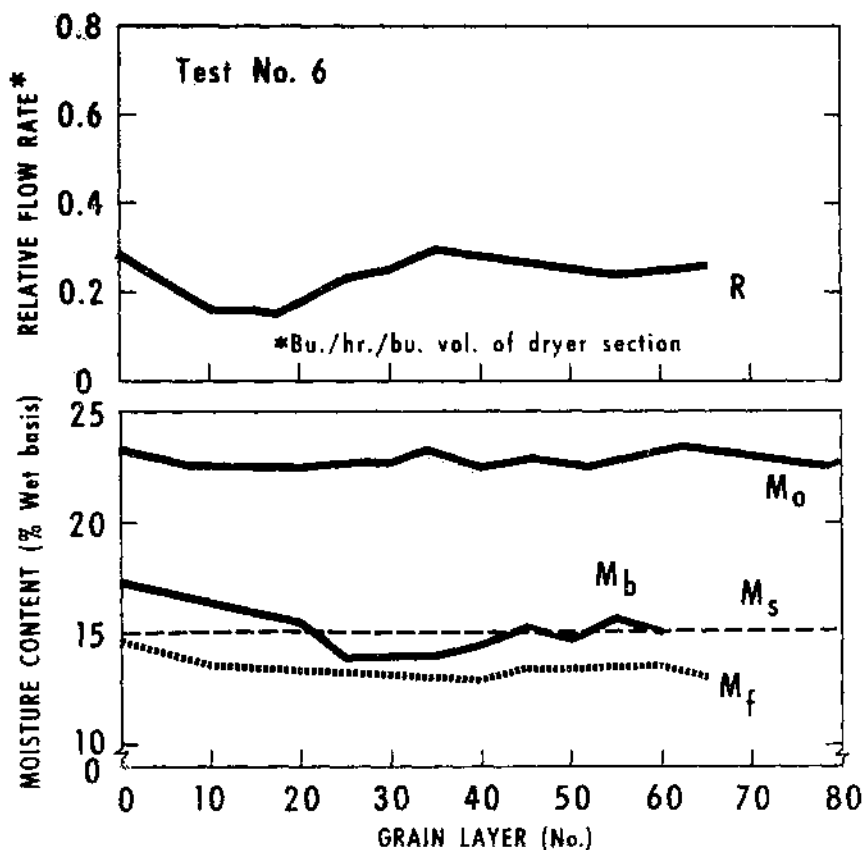

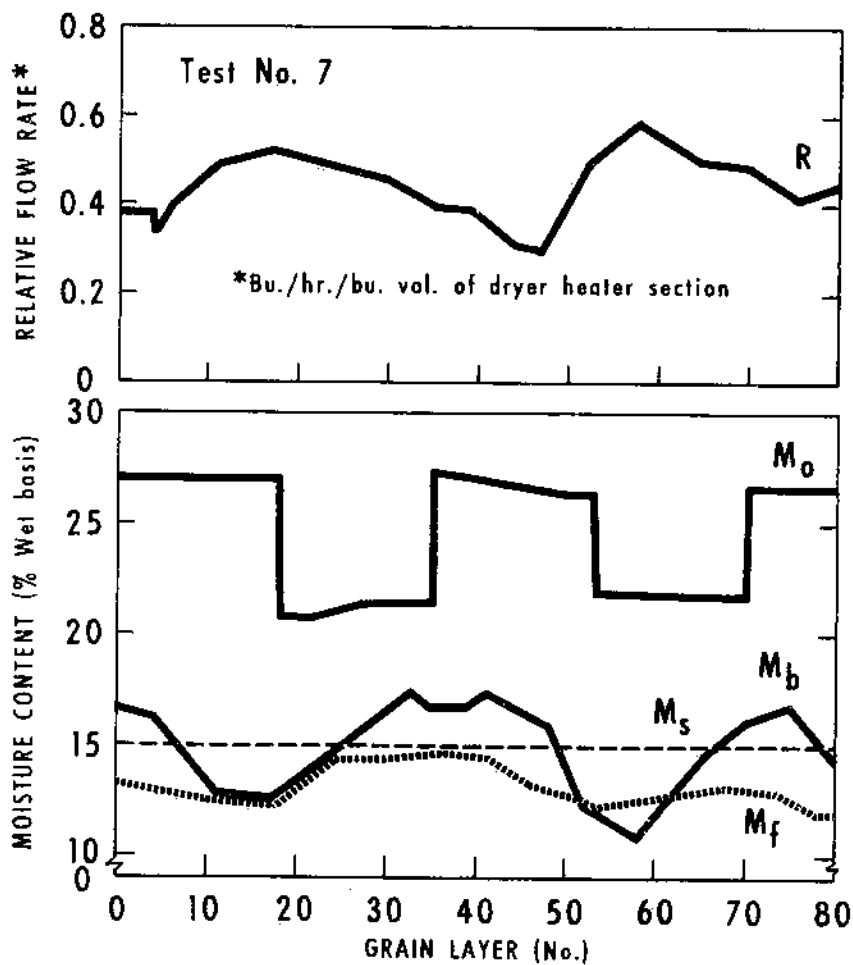

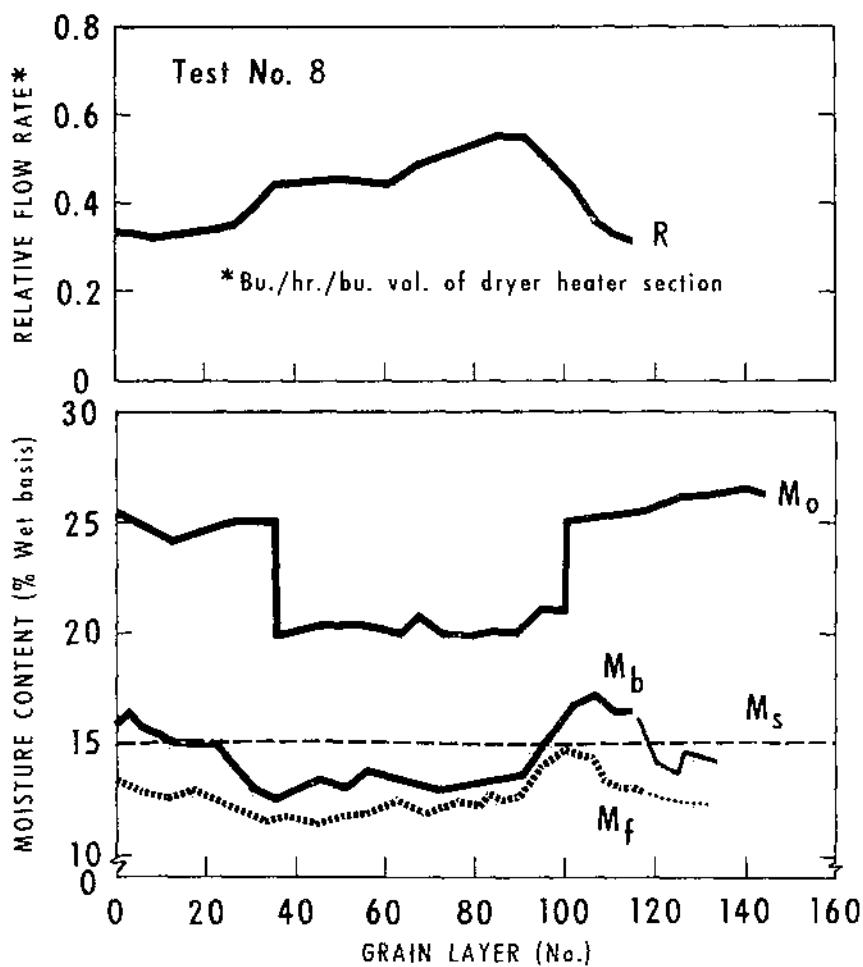

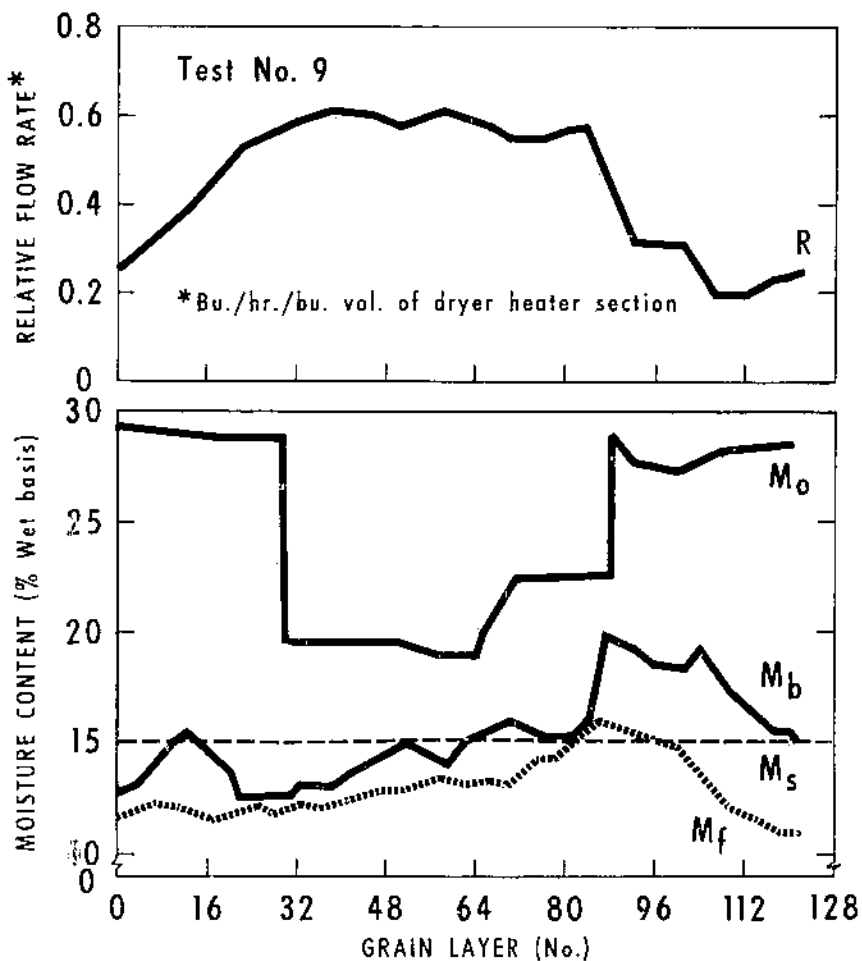

The symbols used in figure 14 are defined as follows:

M_0 = initial moisture content of grain layer as it enters top of dryer.

M_b = moisture content of layer at sampling point (bottom of dryer heater section).

M_s = set moisture content to be maintained by controller (15 percent moisture content used throughout test series).

M_f = final moisture content of layer leaving dryer after cooling.

R = relative flow rate of layer as it passes sampling point. Flow rate, R , was established by the control action of the controller resulting from the moisture error.

The results of the performance tests were satisfactory with one exception. In test 1 the reset action appeared to be too slow, as evidenced by the slow rate at which M_b approached M_s . The problem was not entirely the controller response. The method of placing the system on automatic control also affected the results. In starting each test the drying time was estimated for the particular test conditions. Two hundred bushels were run through so that the dryer approached steady state operation before the controlled test was started. The drying time was estimated to provide a final moisture content of 15 percent, and any error in the estimate resulted in an initial error when starting the test. This created a problem in that only the reset mode functioned to bring about the correction—a situation that would not exist under normal operation of an automatically controlled dryer. In subsequent tests a method was developed where both proportional and reset action took place in the normal manner.

The control system did not compensate for any variation in the amount of drying that occurred in the cooling section. The drying in the cooling section was considered to be relatively constant. Test 1 was run on a day with high humidity and continuous heavy rain and there was no drying in the cooling section, whereas drying of 1.5 to 2 percent occurred during cooling in the other tests. Test 7, with the 25- to 20- to 25-percent step changes at 100-bushel intervals, began to approach the natural frequency of the system and caused large variations in M_b . Mixing action in the cooling section tended to reduce these variations. The mixing action in the cooler and errors in establishing the time a given layer arrived at the two sampling points (M_b and M_f) could have accounted for M_f being greater than M_b at one point in test 7 (fig. 14).

Laboratory Dryer

Following the full-scale field tests, the control system was further evaluated using the laboratory dryer. The objective of these tests was to determine the effect of various proportional constants and reset rates. Constants were selected to obtain data for the operation over a wide range of possible settings. Tests 10, 11, and 12 were run in the laboratory dryer where a grain layer consisted of only 0.10 bushel. The constants selected for the specific tests are shown in table 5.

TABLE 5.—Controller constants for laboratory dryer tests

| Test | Proportional band | Reset rate |
|---------|-------------------|------------------|
| | (dial readings) | (scale readings) |
| | <i>Number</i> | <i>Number</i> |
| 10..... | 2 | 0 |
| 11..... | 20 | .04 |
| 12..... | 100 | 1.00 |

Tests 10, 11, and 12 (fig. 15) demonstrate the effect of different proportional band and reset rate settings. In test 10 the proportional band dial setting was 2 and the reset rate setting was zero. The proportional band setting was increased and reset action added for test 11. The result of reset action can be seen in the gradual reduction in the relative flow rate. Test 12 shows the effect of large reset action. The rapid reset action resulted in an unstable condition and large oscillations developed.

PERFORMANCE EVALUATION AND CONCLUSIONS

A summary of the mean, mean deviation, and standard deviation for the initial (M_0), sampled (M_s), and final (M_f) grain moisture contents for each of the 12 tests is presented in table 6. Also given are the proportional-band and reset-rate controller settings for each test and the proportional and reset action achieved from these settings.

The proportional band settings in the table are the values on the dial of the instrument and not the actual values applicable to the system. Field modification of the controller after test 6

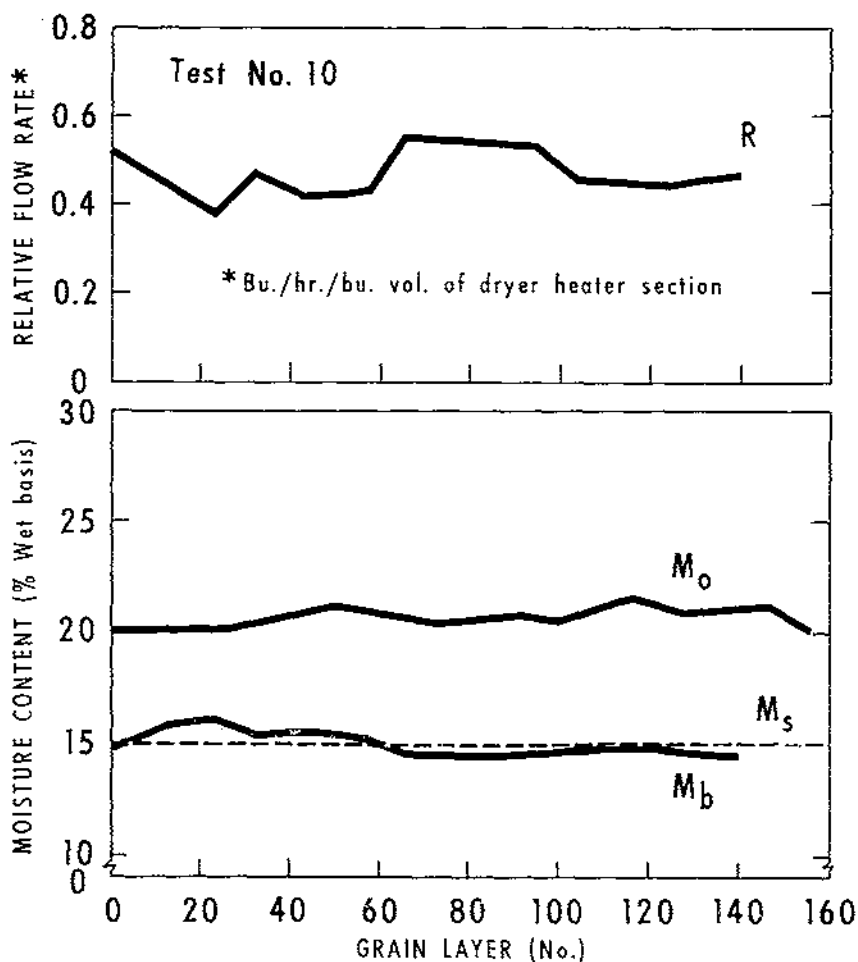
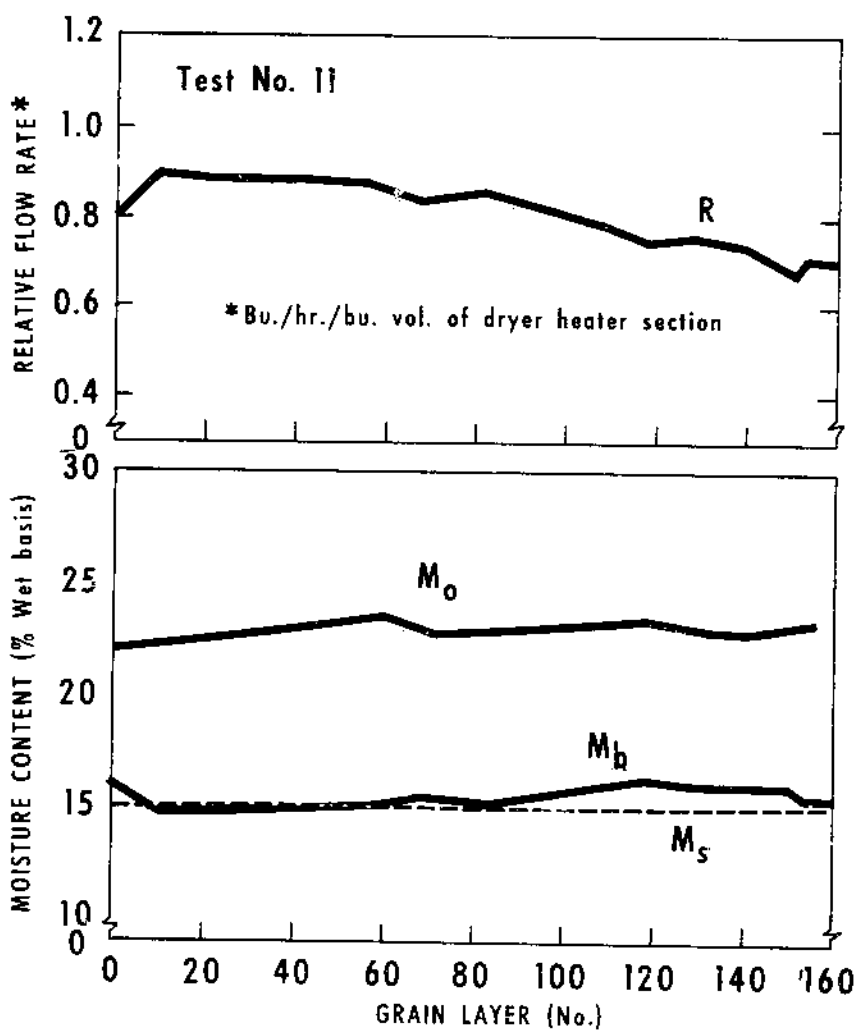
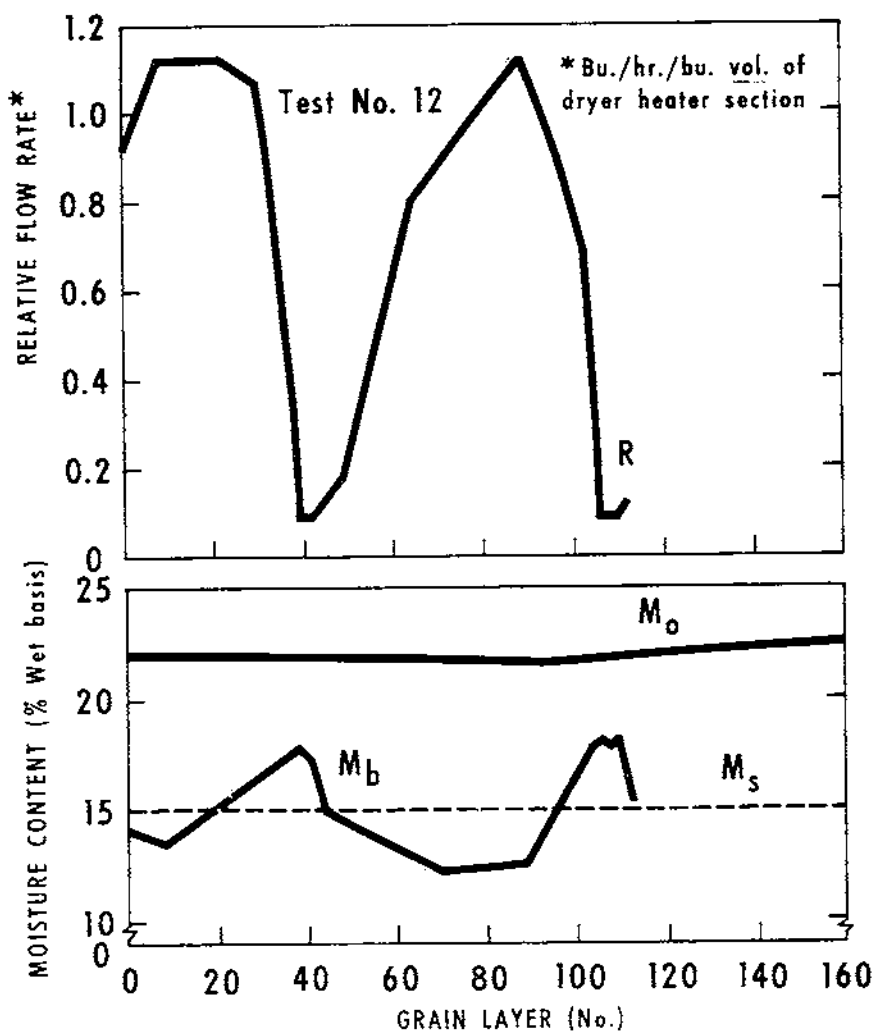

FIGURE 15.—Relative grain flow rate and moisture data versus grain layer number for performance tests 10, 11, and 12 with laboratory dryer. (For explanation of symbols, see p. 38).





improved the reset action and made a noticeable change in the proportional band calibration. The setting of the proportional band was reestablished by adjusting the instrument until the correct relationship between the change in error and the change in grain flow rate (proportional constant, K_c) was established. The same proportional constant was used throughout the full-scale dryer test sequence. The proportional band dial reading was recorded to insure that any unintentional change in the setting could be detected and to provide relative values for comparative purposes. The proportional action reported in table 6 was computed from the drying test data and is therefore a measure of the actual system response rather than the value set on the controller.

The inconsistent reset action of the controller was the major shortcoming of the control system. The long lag in the drying process required a very slow reset action, much slower than is required in the normal application of available controllers. Although specifications for the controller used in these tests indicated that sufficiently low reset rates were attainable, it was found that performance was marginal under these conditions. At low reset settings the reset rate for a positive error differed noticeably from that for a negative error. Field modifications to correct for this shortcoming were only partially successful.

The accuracy of the control system in maintaining a uniform final grain moisture content under the conditions of the test was evaluated by the statistical analysis reported in table 6. The severity of these tests relative to actual operating conditions must be considered in interpreting these data. Step changes of this magnitude are not commonly encountered in dryer operation, since some mixing normally occurs in holding bins or in the garner above the dryer.

The step change is the most severe disturbance that would be encountered in field operations. To insure a step change in the performance tests, the grain in the garner bin on the dryer was leveled prior to introducing grain with a different moisture content. An added test was imposed by alternating the layers rather than allowing the control system to reach a steady state following a disturbance. In actual practice the errors indicated in tests 1, 2, and 3 would be indicative of anticipated errors under normal operating conditions.

From the results of the tests, a proportional band setting of 50 and a reset rate setting of 0.07 appeared to give good results. These settings gave an average proportional action of 0.06 bushel

TABLE 6.—*Statistical analysis of initial, sampled, and final grain moisture contents and proportional and reset actions resulting from various controller settings*

| Test | Initial moisture content (M_i) | | | Sampled moisture content (M_s) | | | Final moisture content (M_f) | | | Controller | | | |
|---------|------------------------------------|-------------------|--------------------|------------------------------------|-------------------|--------------------|----------------------------------|-------------------|--------------------|---------------------------|--------------------|----------------------------------|--------------------|
| | Mean | Mean deviation | Standard deviation | Mean | Mean deviation | Standard deviation | Mean | Mean deviation | Standard deviation | Proportional band setting | Reset rate setting | Proportional action ¹ | Reset action |
| | Percent | Percentage points | Percentage points | Percent | Percentage points | Percentage points | Percent | Percentage points | Percentage points | | | | Repeats per minute |
| 1----- | 25.79 | 0.119 | 0.155 | 13.67 | 0.30 | 0.33 | 13.78 | 0.18 | 0.25 | 50 | 0.10 | 0.033 | 0.04 |
| 2----- | 25.61 | .198 | .264 | 14.61 | .30 | .34 | 12.76 | .43 | .51 | 50 | .10 | .040 | (²) |
| 3----- | 25.82 | .415 | .509 | 14.80 | .73 | .93 | 13.28 | .41 | .55 | 50 | .10 | .058 | (²) |
| 4----- | 20.03 | .248 | .290 | 14.61 | .74 | .86 | 13.51 | .57 | .67 | 50 | .07 | .086 | (²) |
| 5----- | 20.73 | .492 | .541 | 15.04 | .29 | .37 | 13.89 | .36 | .44 | 50 | .07 | .050 | (²) |
| 6----- | 22.79 | .268 | .354 | 15.30 | .82 | .99 | 13.47 | .44 | .60 | 50 | .07 | .060 | .033 |
| 7----- | 23.56 | 2.82 | 3.15 | 14.82 | 1.64 | 1.89 | 13.33 | .71 | .84 | 3 | .07 | .054 | .021 |
| 8----- | 23.54 | 2.37 | 2.64 | 14.36 | 1.25 | 1.40 | 12.63 | .66 | .86 | 4 | .07 | .037 | .018 |
| 9----- | 25.05 | 3.88 | 4.20 | 15.33 | 1.54 | 2.02 | 13.10 | 1.11 | 1.38 | 4 | .07 | (³) | (³) |
| 10----- | 20.70 | .440 | .516 | 14.97 | .47 | .54 | ----- | ----- | ----- | 2 | 0 | .038 | 0 |
| 11----- | 23.05 | .441 | .557 | 15.44 | .42 | .50 | ----- | ----- | ----- | 20 | .04 | .018 | .014 |
| 12----- | 22.02 | .264 | .349 | 14.97 | 1.79 | 2.10 | ----- | ----- | ----- | 100 | 1.0 | .002 | 19.04 |

¹ Bushels per hour per percent moisture error per bushel volume of dryer heater section.

² Reset action not great enough to evaluate in test.

³ Data not obtained because of recorder breakdown.

per hour per percent moisture error per bushel volume of the dryer heater section and an average reset action of 0.03 repeat per minute. These actions appeared to be optimum for operation when drying grain with a moisture content of 23 percent wet basis using 190° F. drying air. For optimum results at other moisture contents, the controller settings should be decreased slightly for moisture contents above 23 percent and increased slightly for moisture contents below 23 percent. For optimum results at other drying air temperatures, the controller settings should be increased slightly for temperatures above 190° and decreased slightly for temperatures below 190°. The optimum reset rate is a function of the drying time, and the change of any variable increasing the drying time would require a reduction in reset rate for optimum control provided the proportional constant is unchanged.

The control system would have no difficulty in compensating for normal changes in drying air temperature, relative humidity, and airflow rate. Major changes in airflow rate or drying air temperature that would significantly change the drying time would require readjustment of both the proportional band and reset rate settings.

The control system can be readily adapted to any common continuous-flow dryer. The sampling augers would be positioned in the drying column to give a representative sample of the grain as it leaves the heater section. The percentage timer can be easily installed to interrupt the electrical power supply to the continuous-flow drive motor and thus regulate the flow of grain through the dryer. The timer could be used to operate a ratchet and pawl drive or a clutch on any dryer not having a separate drive motor on the grain discharge metering system.

The capacity of the dryer would not be changed by the addition of the control system as compared with that of a manually controlled dryer.

ALTERNATE CONTROL METHODS

Controller

A detailed discussion of various alternate controller modes is presented in the published report on simulation (19).

Many types of equipment are available to provide a given control action such as the proportional plus reset employed in the prototype system. Controllers available from other manufacturers

may provide the required low reset rates; however, extensive testing is recommended to validate the specifications.

A transistorized three-mode controller was made available on loan from Honeywell, Inc., after completion of the drying tests. The controller was subjected to a series of tests where a given step change was introduced to a potentiometer simulating the one used on the test moisture meter. The response was recorded on the moisture content and flow rate recorder used in the dryer tests. The reset rate setting was adjustable in definite steps rather than continuously, and the lowest available step greater than zero resulted in a reset rate faster than required. Although the reset rate was slightly high, the reset action was the same for either a plus or minus error. The desired reset rate could very likely be achieved by slight modifications in the controller.

Pneumatic control could provide the low reset action desired; however, this method requires a source of clean compressed air, which is frequently not as readily available as electrical power. This method was not employed in the prototype system because of the requirement for compressed air and the more complicated problem of a transducer for converting the output of a pneumatic controller to action needed to regulate the flow of grain.

Moisture Measurement

Continuous measurement of moisture would simplify the sampling section of the control system and provide for the application of the desired rate control mode. However, the cost of equipment for continuously measuring the moisture content was prohibitive at the time of the investigation and its reliability had not been proved.

Exhaust air temperatures provide continuous indication of moisture content during the drying process. The exhaust air temperature is a function of the drying air temperature, airflow rate, and drying rate. Any change in drying air temperature or airflow would give a change in indicated moisture content independent of actual moisture content. The effect of drying history on the drying rate at the measuring point is also introduced as an error in the indicated moisture content. Such a system also requires a manually controlled period for the grain to warm up following a shutdown. The extremely low cost of this system partially compensates for the shortcomings for selected applications. Control units operating on the temperature sensing principle are available on some dryers, including farm-size units.

COMPUTER SIMULATION

Digital computer simulation of the grain drying process and automatic control system was investigated. Simulation proved to be a valuable tool in the design and evaluation of grain dryer-control systems. Four control systems were investigated using the computer model. These were proportional plus reset, feed forward, on-off, and combination on-off and proportional plus reset.

A search technique was used to allow the computer to determine the optimum control system settings. This was accomplished by considering the response of the control system to a step change in initial grain moisture and computing a performance index. The performance index was determined by computing the product of the square of the error in controlled moisture times the number of bushels that were discharged with that error.

In the optimization of the proportional plus reset system, the proportional sensitivity and reset time constant were adjusted successively to locate the values resulting in the best performance index. The resulting optimal values were found to be a function of the process time lag. A system providing optimum response under a given set of conditions was not optimum under any other conditions and was found to be unstable under certain conditions. This characteristic showed that a sacrifice in response under some conditions would be required to insure stability under all anticipated operating conditions. Manual adjustment of proportional band and reset rate would be required to provide optimum response.

Since optimum values are a function of the process time lag, the drying air temperature and airflow rate would also be important. These factors would not be expected to pose a problem, since they are normally maintained relatively constant. Normal random variations in temperature and airflow would not create problems, and any major adjustments made by the operator could be corrected by also adjusting the moisture controller.

A combination of the on-off control and proportional plus reset considered in the simulation provided very good control. The system was designed to stop the flow of grain from the dryer when the moisture exceeded 15.5 percent with a set point of 15 percent and thereby eliminate the discharge of wet grain. When the grain had dried to below 15.5 percent, the discharge of grain was continued and the system functioned as the normal proportional plus reset system. The proposed control slide-wire was designed to provide a small reset action when the grain was held

stationary in the dryer, and it caused the rate of discharge during the subsequent "on" period to be reduced. In this way the dryer returned to a steady state operating condition following an increase in initial moisture content. The response to a decrease in initial moisture content would be the same as that resulting from the proportional plus reset control.

A feed-forward system was considered that employed a controller to regulate the flow of grain from the dryer as a function of the initial grain moisture content. The conventional feedback system was used to correct for any error existing at the bottom of the dryer. This system offered very little improvement over the feedback system alone. The slight improvement would not justify the additional equipment required to sense the initial moisture content.

An on-off control system employing periodic sampling was investigated using the computer model. The idealized conditions imposed in the simulation actually represented the worst conditions that could be encountered in the field application of an on-off control. Even under these conditions the system showed promise for application where wide and rapid variation in initial moisture might be expected. The on-off system also has an advantage in being a relatively low cost control.

The simulation and optimization investigations are described and discussed in detail in "Simulation of a Moisture Control System for a Continuous-Flow Dryer" (19). The authors discuss the drying system parameters used, the mathematical model, simulation of the drying process and control modes, optimization, and the results achieved.

SELECTED REFERENCES

- (1) BROCKELSBY, C. F.
1951. INSTRUMENT FOR ESTIMATING MOISTURE CONTENT OF GRAIN BY ELECTRICAL CONDUCTION. *Cereal Chem.* 28: 81-94.
- (2) CHESTNUT, HAROLD, and MAYER, R. W.
1959. SERVOMECHANISMS AND REGULATING SYSTEM DESIGN. V. 1, 680 pp. New York.
- (3) COLEMAN, D. A., and FELLOWS, H. C.
1938. HANDBOOK OF INSTRUCTIONS FOR THE INSTALLATION AND OPERATION OF THE TAG-HEPPENSTALL MOISTURE METER. Rev. ed. U.S. Bur. Agr. Econ. USGSA-MB 1-1, 93 pp.
- (4) COOK, W. H., HOPKINS, J. W., and GEDDES, W. J.
1934. RAPID DETERMINATION OF MOISTURE IN GRAIN, PART 2. CALIBRATION AND COMPARISON OF ELECTRICAL MOISTURE METERS WITH VACUUM OVEN FOR HARD RED SPRING WHEAT. *Canad. Jour. Res.* 11: 409-447.

- (5) ECKMAN, D. P.
1958. AUTOMATIC PROCESS CONTROL. 368 pp. New York.
- (6) FINN-KELCEY, P., and CLAYTON, P. E.
1957. THE MEASUREMENT OF SURFACE FRICTION OF GRAIN TO DETERMINE ITS MOISTURE CONTENT. Agriculture (Gt. Brit. Min. Agr., Fisheries and Food) 64: 155-156.
- (7) FOSNOT, R. H., and HAMAN, R. W.
1945. A PRELIMINARY INVESTIGATION OF THE APPLICATION OF THE KARL FISCHER REAGENT TO THE DETERMINATION OF MOISTURE ON CEREALS AND CEREAL PRODUCTS. Cereal Chem. 22: 41-49.
- (8) HALL, C. W.
1957. DRYING FARM CROPS. 336 pp. Agr. Consulting Assoc., Inc., Reynoldsburg, Ohio.
- (9) HLYNKA, I., and ROBINSON, A. D.
1954. MOISTURE AND ITS MEASUREMENT. In Anderson, J. A., and Alcock, A. W., Storage of Cereal Grains and Their Products, pp. 1-42. Amer. Assoc. Cereal Chem., St. Paul, Minn.
- (10) JUD, H. G.
1967. BASICS OF CONTROL SYSTEM THEORY. Plant Engin. 21: 156-158.
- (11) MATTHEWS, JOHN.
1963. AUTOMATIC MOISTURE CONTENT CONTROL FOR GRAIN DRIERS. Jour. Agr. Engin. Res. 8: 207-220.
- (12) MILLER, P. S., and JONES, J. J.
1959. MOISTURE DETERMINATION BY MEANS OF RADIO FREQUENCY POWER ABSORPTION. Toilet Goods Assoc. Sci. Sect. Proc. 31 (May), 5 pp.
- (13) MINNEAPOLIS-HONEYWELL REGULATOR COMPANY.
1957. FUNDAMENTALS OF INSTRUMENTATION FOR THE INDUSTRIES. 52 pp. Philadelphia.
- (14) NATIONAL INSTITUTE OF AGRICULTURAL ENGINEERING.
1956. AN INVESTIGATION INTO THE PERFORMANCES OF FIVE TYPICAL RAPID METHODS OF MEASURING THE MOISTURE CONTENT OF GRAIN. Rpt. 46, 43 pp.
- (15) PAULL, A. E., and MARTINS, V.
1949. FACTORS AFFECTING THE DETERMINATION OF MOISTURE IN HARD RED SPRING WHEAT BY COMMERCIAL ELECTRICAL METERS. Canad. Jour. Res. 27F: 479-482.
- (16) SHAW, T. M., and O'MEARA, J. P.
1956. DETERMINATION OF MOISTURE BY NUCLEAR MAGNETIC RESONANCE. Amer. Meat Inst. Council on Res. (Univ. of Chicago) Res. Conf. Proc. 8, pp. 73-82.
- (17) THALER, G. J., and BROWN, R. G.
1953. SERVOMECHANISM ANALYSIS. 414 pp. New York.
- (18) TRUXAL, J. G.
1958. CONTROL ENGINEER'S HANDBOOK. 1 v. New York.
- (19) ZACHARIAH, G. L., and ISAACS, G. W.
1966. SIMULATION OF A MOISTURE CONTROL SYSTEM FOR A CONTINUOUS-FLOW DRYER. Amer. Soc. Agr. Engin. Trans. 9: 297-302.

END