



AgEcon SEARCH
RESEARCH IN AGRICULTURAL & APPLIED ECONOMICS

The World's Largest Open Access Agricultural & Applied Economics Digital Library

This document is discoverable and free to researchers across the globe due to the work of AgEcon Search.

Help ensure our sustainability.

Give to AgEcon Search

AgEcon Search

<http://ageconsearch.umn.edu>

aesearch@umn.edu

*Papers downloaded from **AgEcon Search** may be used for non-commercial purposes and personal study only. No other use, including posting to another Internet site, is permitted without permission from the copyright owner (not AgEcon Search), or as allowed under the provisions of Fair Use, U.S. Copyright Act, Title 17 U.S.C.*

TA 1432 (1971) USDA TECHNICAL BULLETINS UPDATA
PATHOGENIC SPECIALIZATION IN CEREAL RUST FUNGI, ESPECIALLY PUCCINIA
BRONDER, L. E. 1 OF 1

START

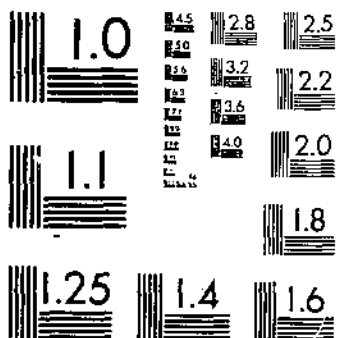

MICROCOPY RESOLUTION TEST CHART
NATIONAL BUREAU OF STANDARDS-1963-A

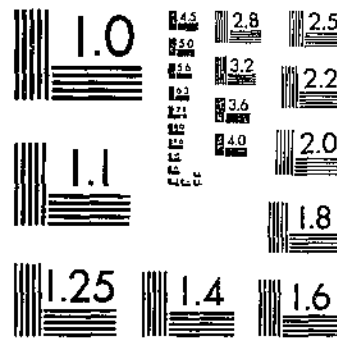

MICROCOPY RESOLUTION TEST CHART
NATIONAL BUREAU OF STANDARDS-1963-A

**Pathogenic Specialization
in
Cereal Rust Fungi, Especially
Puccinia recondita f. sp. *tritici*:
Concepts, Methods of Study,
and Application**

DEPOSITORY.

AUG 25 1971

Los Angeles Public Library

Technical Bulletin No. 1432

**Agricultural Research Service
UNITED STATES DEPARTMENT OF AGRICULTURE
in cooperation with
Kansas Agricultural Experiment Station**

ACKNOWLEDGMENTS

I gratefully acknowledge the contributions of ideas and technical assistance in developing the equipment described herein by K. E. Williams, formerly *agricultural research technician*, Plant Science Research Division, Agricultural Research Service, U.S. Department of Agriculture, and E. S. Baker, *manager*, Q-1 Services, Waverly, Kans. 66871.

Mention of a trademark or proprietary product does not constitute a guarantee or warranty of the product by the U.S. Department of Agriculture and does not imply its approval to the exclusion of other products that may also be suitable.

CONTENTS

	Page
Summary	1
Introduction	2
Objectives of studying pathogenic specialization	4
Genetic basis of host:parasite specificity	5
Experimental designs for studies of host:parasite systems	8
Pathogenic specilization: concepts of race identification and pathogenic potential assay	10
Pathogenic specialization to genes for adult plant resistance	14
Brief history of studies of specificity in wheat leaf rust	15
Methods and procedures of assaying pathogenic potential	18
Parasite population sampling	18
Procedures of analysis	20
Presentation of data concerning pathogenic potential	24
Equipment development	25
Mechanized "differential set" seeder	25
Cyclone spore collector	26
Plastic isolation cage	30
Spore-oil suspension atomizer	30
Automated inoculation booth	31
Refrigerated cabinet-type moist chamber	35
Compendium of techniques useful in culturing <i>Puccinia</i> <i>recondita</i> f. sp. <i>tritici</i>	37
Urediospore increase	37
Urediospore collection	38
Urediospore preservation	40
Inoculation with urediospores	41
Application of knowledge of pathogenic specialization to disease control	45
Literature cited	47

Washington, D.C.

Issued August, 1971

For sale by the Superintendent of Documents, U.S. Government Printing Office
Washington, D.C. 20462—Price 35 cents

Pathogenic Specialization in Cereal Rust Fungi, Especially *Puccinia recondita* f. sp. *tritici*: Concepts, Methods of Study, and Application

By L. E. BROWDER, *research plant pathologist,*
Plant Science Research Division,
Agricultural Research Service

SUMMARY

The gene-for-gene relationship imposes certain limitations on the use of specific genes for resistance in controlling the cereal rust diseases and implies certain procedures for study of pathogenic specialization in the cereal rust fungi. The gene-for-gene model is accepted and used as a basis for discussion of concepts and experimental designs for studying pathogenic specialization and Host:Parasite specificity. These designs in all cases depend upon derivation of information about an unknown on the basis of its interaction with a known. We need to improve the standardization of the knowns used in these studies.

Race identifications tend to obscure information concerning Host:Parasite specificity relationships. Therefore data of pathogenic specialization would be more meaningful if presented on the basis of virulence to single host cultivars or as virulence corresponding to single genes for resistance and as parasite virulence association coefficients.

A brief consideration is made of the relation of adult plant re-

sistance in wheat to Host:Parasite specificity in wheat leaf rust. Some forms of adult plant resistance are of the same order of specificity as the seedling resistances on which most studies of pathogenic specialization are based. This phenomenon, although useful in disease control, imposes difficulties on pathogenic specialization studies from a purely logistical standpoint. We need improved methods of studying specialization at the adult level.

The practical objectives of studying pathogenic specialization may be: (1) To support disease control by plant breeding to incorporate specific resistances into commercial cultivars and (2) to support epidemiological investigations and disease prediction systems. The overall objectives of assaying pathogenic potential in parasite populations include the detection of new virulences and the measurement of changes in pathogenicity to various host materials in terms of both time and space.

Because these objectives are diverse, the methods and pro-

cedures available for attaining them are also diverse. Three basic parameters concerning parasite populations (virulence frequencies, virulence associations, and virulence distribution) are necessary to fully describe the pathogenic potential of these populations. The degree of accuracy in estimates of these parameters depends first upon ability to sample the population accurately, then upon the methods and procedures used to measure pathogenicity to the host materials, and then upon knowledge of the host materials used. Several possible procedures are cited and discussed. The particular objective of a given study, as well as the time and support available for

the study, must be considered in choosing methods.

A mechanized system of planting host materials in the greenhouse and of growing, isolating, and inoculating host materials with cultures of *P. recondita* f. sp. *tritici* is described. The system was designed to improve the efficiency and accuracy of pathogenic potential assays, in accord with the concepts discussed. Certain techniques useful for culturing *P. recondita* f. sp. *tritici* under greenhouse conditions are also described.

A brief history of studies of pathogenic specialization in the parasite causing wheat leaf rust is given, and the application of knowledge of pathogenic specialization is discussed.

INTRODUCTION

The discovery of pathogenic specialization at the host cultivar level in the cereal rust fungi (57)¹ and the subsequent application of this information in developing commercial cultivars having genes for specific resistance have been important in the control of the cereal rusts. The early practical breeding work for resistance to rust used information derived from studies of relationships of the rust fungi to certain "standard" differential cultivar sets, although Stakman and Levine

(55) pointed out that other combinations of differential host would probably show many more "forms." The standard differential sets became widely used internationally for identification of pathogenic races in studies known as "race surveys." In many cases, local cultivars were also used. The results of these studies later indicated there were important differences in pathogenicity of these fungi not described by standard race. The importance of these differences was clearly and dramatically brought to the attention of plant pathologists and plant

¹ Italic numbers in parentheses refer to Literature Cited, p. 47.

breeders working with the problem by the disastrous outbreak of race 15B of *Puccinia graminis* Pers. f. sp. *tritici* in the North Central United States and Canada in the early 1950's (58). Since that time, most studies of pathogenic specialization have included cultivars other than the standard cultivars. These are now generally known as "supplemental" differentials. Attempts to convey information about parasite populations relating to sets of differentials other than the standards by race designations have resulted in confusion of nomenclature and uncertainty in interpreting data, because the nomenclatural basis of race designations has not always been clear.

The genetics of Host:Parasite relationships has been greatly elucidated in the past 15 years. Data of Flor (20) first indicated a gene-for-gene relationship in *Linum usitatissimum* L. and *Melampsora lini* (Ehrenb.) Lev. in 1942 although it was not proposed as such at that time. The disastrous epidemics of race 15B also gave impetus to further understanding that hypothesis as a means of explaining the observed phenomena. Presently (1971), the general principles of Host:Parasite genetics in the cereal rusts are understood although details are lacking (33, 40).

The most important conclusion derived from proof of the gene-for-gene relationship is that a specific gene for resistance prob-

ably will not give permanent control when used extensively. This conclusion should not prevent use of different specific resistances, but warns that carefully planned manipulation of specific genes for resistance into commercial cultivars will be necessary for adequate crop protection.

The first requisite to adequate manipulation of genes for resistance is the revision of studies of pathogenic specialization of the cereal rust fungi to produce usable genetic information. This paper is an attempt to evaluate present knowledge, to clarify concepts and objectives, to state problems, to describe recently developed equipment, and to describe some techniques currently used in studying pathogenic specialization in the cereal rust fungi. Concepts and objectives must be clarified before further substantial progress can be made. Many of the problems to be discussed, especially those concerning sampling parasite populations and methods of handling, analyzing, and presenting data, remain unresolved. However, I think it useful to consider them to emphasize them as problems that need solving. Although this paper deals largely with methods, procedures, and equipment for studying pathogenic potential of cereal rust fungi, the genetics of Host:Parasite relationships will be discussed briefly because such studies must logically be based on knowledge of those relationships.

In this paper I use wheat leaf rust (*Triticum* spp. : *Puccinia recondita* Rob. ex. Desm.) for ex-

amples, but the discussion is generally applicable to other cereal rusts also.

OBJECTIVES OF STUDYING PATHOGENIC SPECIALIZATION

The phenomenon of pathogenic specialization has been known long enough and its underlying mechanisms are so well understood that study of pathogenic specialization with description as the sole objective has little value or appeal. Yet the use of specific resistance still has great potential value in rust control, and pathogenic specialization has a profound influence on disease development. Thus, studies of pathogenic specialization should be closely coordinated with plant breeding programs developing cultivars having useful specific resistance and with studies of epidemics. Studies of pathogenic specialization should support these applied areas (56).

The ultimate objective in supporting plant breeding programs is to provide host materials having useful genes for resistance in relation to prevailing parasite populations. The attainment of this objective requires two types of sampling:

(1) A sampling of available host materials to identify potentially useful genes for resistance, and

(2) A sampling of the naturally occurring parasite populations to detect new or unusual genes

for virulence and to measure frequencies and associations of genes for pathogenicity to currently used and potentially useful genes for resistance. In practice, it is usually desirable to use different sampling techniques for studying different aspects of parasite populations.

Study of host and parasite is equally important in attaining the plant breeding support objective. These two kinds of sampling are so closely related in principle that they should not be separated in work programs. Selected cultures of the parasite are used in the search for genes for resistance; selected cultivars of the host are used in the assay of parasite populations for pathogenicity. These studies seek the unusual in both host and parasite. In the search for genes for resistance, host materials are first tested in the field to eliminate some materials and then are further evaluated by seedling tests in the greenhouse. The best of these materials, those having genes for resistance to the greater part of the parasite test cultures, should then be used as knowns (standards) in studying parasite populations. The study of pathogenicity in parasite populations

is the chief concern of this paper, though the need for study of host variation is recognized.

Studies of pathogenic specialization have all too often been used merely to explain past behavior of crop cultivars. Knowledge that a cultivar is no longer useful because parasite gene frequencies have changed ("because a new race attacks it") is of little positive value. We need now to develop accurate methods of predicting changes in pathogenic potential of parasite populations. We must be able to predict not only that changes will occur but also the future pathogenic potential. Only through this means can we attain long-term useful resistance without "gap periods" when no usefully resistant cultivars are available.

The epidemiological objective of studying pathogenic specialization deals with measurement of changes of parasite pathogenic potential in time and space and

in relation to commercially grown cultivars. This objective has at least two aspects. The information can be used either in tracing inoculum movement or as one factor in predicting probability of epidemic development in a given area when the source of inoculum, its pathogenic potential, and the genetic constitution of host materials in the subject area are known and environment can be predicted. This use of information from pathogenic specialization studies has been secondary to the plant breeding objective in the past. With increased interest in epidemiology, this use of information must be emphasized in the future.

To be of practical use in either plant breeding or epidemiology, timeliness in gathering and distributing information is very important because the explanation of past events is of little or no value unless that knowledge aids in control of future events.

GENETIC BASIS OF HOST:PARASITE SPECIFICITY

The genetic basis of Host:Parasite specificity in cereal rusts is generally accepted to be a gene-for-gene relationship of host genes for reaction and fungus genes for pathogenicity. This relationship was first described by Flor in the *Linum:Melampsora* system (21). The phenotypic expression of these relationships is controlled by the interaction of

corresponding gene pairs. Person (40) provided a mathematical model for such a system and proposed that it was generally applicable to Host:Parasite systems. A gene-for-gene relationship has since been demonstrated experimentally in several Host:Parasite systems (40, 45, 62).

Genetic information concerning either host or parasite can be

derived from infection type when information about the opposite member and environment is known. Infection type is a character of the Host:Parasite relationship and depends upon the genotype of both host and parasite as well as upon the prevailing environment. Loegering (33) has emphasized the need for acceptance of this concept and its implications. Loegering has also coined the term "aegricorpus" to describe the "single living manifestation of specific genetic interactions in and between host and pathogen" as distinguished from disease as a process destructive to the host. Further, he has suggested a set of uncontradicting terms to describe variation of host, pathogen, and aegricorpus.

In Loegering's terminology, the host has a character, reaction, which may have a phenotype of either resistance or susceptibility; the pathogen has a character, pathogenicity, which may have a phenotype of either avirulence or virulence; and the aegricorpus has a character, infection type, which may be either low or high. Infection type is a relative ranking; specific infection types depend upon specific functioning corresponding gene pairs. In each case, the phenotypes are associated with specific genotypes.

In this paper, the concepts and terminology of Loegering (33) are used except that the word "parasite," rather than "pathogen," is used in the couplet with

host (23). Using these concepts and terms and assuming a constant environment, the simplest general model of the gene-for-gene relationship may be illustrated as:

		Host genotype for reaction	
		R-	rr
Parasite genotype for pathogenicity	P-	Low I.T.	High I.T.
	pp	High I.T.	High I.T.

Where: R- = resistance
 rr = susceptibility
 I.T. = Infection Type
 P- = avirulence
 pp = virulence

A single gene difference and complete dominance are assumed.

Only the interaction of host genes for resistance and parasite genes for avirulence effects a low infection type. The interaction of resistance:virulence, susceptibility:avirulence, and susceptibility:virulence effect high infection types which are indistinguishable from each other. Thus, a low infection type always indicates resistance in at least one host reaction locus and avirulence at the corresponding parasite locus for pathogenicity. But when a high infection type occurs, accurate information concerning one contributing member of the aegricorpus must be known before any useful information about the other contributing member can be determined. This model provides a way to derive probable genotypes of either member of the in-

teraction from infection type data in some cases when accurate information of the opposite member is known.

The model above is intended only as a general working model to which there may be exceptions. Dominance-recessiveness in different corresponding gene pairs may vary and the relationship need not be a strict one:one but could be a two:one, one:two, or other numerical relationship (40). These possible exceptions, however, do not alter the basic nature of the interaction system. The model is derived from the models of Person (40), Flangas and Dickson (19), and particularly from Rowell and Loegering (43).

Because susceptibility:avirulence, susceptibility:virulence, and resistance:virulence result in a high infection type, there can be no equivalence of terms describing host and parasite. Thus, host cultivars with genes for resistance do not become susceptible; however, their resistance may become ineffective with changes in parasite populations.

The model shown above assumes only one varying corresponding gene pair; however, in most Host:Parasite systems many such corresponding gene pairs are operative. More than one corresponding gene pair incurs varying combinations of genes for resistance in the host and varying combinations of genes for avirulence in the para-

site. Thus, the model must be expanded geometrically to show all the possibilities of interaction as they occur in nature. Person (40) has shown a five corresponding gene pair model. Further expansion soon becomes very unwieldy, but nevertheless would be necessary to depict all the variability possible in most Host:Parasite systems.

Pathogenic specialization, then, involves phenotypic expression of varying combinations of host genes for reaction interacting with varying combinations of fungus genes for pathogenicity. It is a phenomenon involving interaction of two populations, host and parasite, and must be treated as such.

The model shown above is presently (1971) the best model available on which to base studies of pathogenic specialization. Race survey studies cannot presently be completely reconciled with this model because adequate materials are not yet available and details of host genotypes are not yet adequately known. But the model represents our best understanding of the genetic basis of pathogenic specialization and should serve as a working hypothesis.

Because practical studies cannot presently be completely reconciled with the mathematical model, we also need interim working methods and terminology. Thus, some terms used above may be used in this paper at times with slightly different meanings,

particularly the term "virulence," which may be used in some cases in relation to host cultivars rather than to genes for resistance. Virulence to a cultivar means virulence to all genes for

resistance carried by that cultivar. This interpretation is necessary because we lack detailed knowledge of most host materials being studied.

EXPERIMENTAL DESIGNS FOR STUDIES OF HOST:PARASITE SYSTEMS

Infection type is a character of the Host:Parasite interaction (aegricorpus) and provides a basis from which information may be derived concerning either the host or parasite. The extent and accuracy of information derived concerning one contributing member of the aegricorpus wholly depends upon the extent and accuracy of information *known* about the opposite contributing member. All studies of Host:Parasite systems using infection types as measurement criteria are subject to this limitation; these studies are made to gain information about host or parasite by subjecting a sample of an unknown of one member to a known of the other member, using inoculation procedures and observation of the resulting infection types. Using the model shown in the previous section as a basis, table 1 shows some possible experimental designs that can be constructed and the conclusion derived when either a low or high infection type is observed in each design. Designs 2 and 5 are the most useful, deriving information about parasite and host, re-

spectively, because host genes for resistance and fungus genes for avirulence interact to produce a low infection type. The other designs listed are less useful, but even Design 1 (unknown + unknown) produces some information when the low infection type is observed, particularly in the search of new corresponding gene pairs. Designs 3 and 4 are essentially like Design 1 and are also useful in searches for new corresponding gene pairs.

One other fact is important here: the infection type conditioned by a specific corresponding gene pair in a constant environment is a nonvariable character (33). Specific low infection types are characteristic of each interaction of corresponding genes for resistance and avirulence. Thus, specific infection types rather than infection type ranges must be used as measurement criteria when detailed genetic inferences are sought. Characteristic low infection types allow reasonably positive identification of corresponding gene pairs by observation of discrete infection types. Specific infection

TABLE 1.—Some experimental designs used in pathogenic specialization studies

Design No.	Host	Parasite	Aegricorpus infection type	Conclusion
1	Unknown	Unknown	Low	At least one gene for resistance and its corresponding gene for avirulence operating.
			High	
2	Known resistance	Unknown	Low	Parasite <i>avirulent</i> or heterozygous for corresponding gene(s) for pathogenicity.
			High	
3	Known susceptible	Unknown	Low	Corresponding gene pair(s) other than "known" are operating.
			High	
4	Unknown	Known virulence.	Low	Corresponding gene pair(s) other than "known" are operating.
			High	
5	Unknown	Known avirulence.	Low	Host <i>resistant</i> or heterozygous for corresponding gene(s) for reaction.
			High	

types can sometimes be used to obtain information of probable parasite genotypes when a host cultivar carries two or more known genes for resistance that, along with their corresponding gene for avirulence, result in different and discrete low infection types.

Samborski (46) distinguished parasite cultures that carried genes for virulence to one or both of two genes for resistance by observing 0; 0;—2, and 4 infection types on 'Exchange.' Cultures producing 0; infection types on 'Exchange' had the gene for avirulence to at least one gene for

resistance (the one that, with its corresponding gene for avirulence, conditioned the 0;). A 0; infection type yielded information concerning only a single parasite gene. The allelic condition of the other gene for pathogenicity was not known. The lowest infection types have thus far been "epistatic" when two or more corresponding gene pairs were operative (33). Additive effects of two corresponding gene pairs have also been reported (3, 48).

Cultures producing 0;—2 infection types had the gene for virulence to one gene for resistance

(the one conditioning the 0;) and cultures producing infection type 4 had genes for virulence to both genes for resistance; that is, both the gene for resistance involved in conditioning the 0; and the gene for resistance involved in conditioning the 0;—2, when their corresponding genes for avirulence were present.

These designs provide the basis for most studies of Host:Parasite relationships in the cereal rusts except that known host genotypes and known parasite genotypes *may* be used as standard checks. Other designs are possible, but are of little value.

PATHOGENIC SPECIALIZATION: CONCEPTS OF RACE IDENTIFICATION AND PATHOGENIC POTENTIAL ASSAY

Studies of pathogenic specialization have been closely associated with race identification. The differences between pathogenic specialization and race identification should be noted, as Simons (51) has emphasized. Pathogenic specialization is the broad natural phenomenon indicated by observations that parasite entities are more pathogenic to some host cultivars than to others. Race identification, however, is a means by which pathogenic specialization has been studied, a means of classifying and naming parasite variation. In the procedures used to study pathogenic specialization by race identification, the genetic constitution of the host is held as

a constant and environment is held fairly constant. Observations are made of several aegricorpi, and information about the parasite is derived indirectly. Pathogenic specialization and "race" are both characteristics of the parasite involved in a Host:Parasite relationship, one natural, the other artificial. Stakman, Stewart, and Loegering (59) have generally defined a race as "a biotype or group of biotypes, within a species or lower taxon, which can be distinguished with reasonable facility and certainty from other biotypes or groups of biotypes by physiologic characters, including pathogenicity." More specifically applied to the

rust fungi, a pathogenic race is a group of cultures of a parasite causing a given combination of infection types, or a range of infection types, on a specified set of differential host cultivars. Because different sets of cultivars may be specified by publication, there may be different kinds of races in a given parasite species; these kinds of races need not necessarily be related to each other.

Traditionally, race numbers without prefix refer to races identified on the "International Standard" sets of differential cultivars for particular parasite species. Other kinds of races can be identified in exactly the same conceptual sense, but should bear a prefix to specify another set of differentials (1). Stakman (54) and Simons (51) have emphasized that the standard differential cultivars used for various rust fungi are but a small part of the variation available in the host species. Thus, the standard differential cultivars reflect only a small part of the pathogenic potential of the parasites. Only actual testing of cultivars carrying genes for resistance can assay pathogenic potential of the population (51).

Although recognizing the pathogenic race concept as valid when properly used, I submit that it is often misleading because of faulty interpretation and unwarranted extrapolation and that communication of data concern-

ing pathogenic potential of fungus populations may, particularly in relation to breeding cultivars for specific resistance, be better served by other means. The classic pathogenic race concept is inadequate with present (1971) knowledge of pathogenic specialization. In support of this, consider the following points:

(1) Pathogenic race designations portray combinations of genes for pathogenicity in parasite cultures. The mechanics of race identification provides a constant spectrum of host genes for resistance in different host cultivars and places cultures of the parasite into groups (races) according to pathogenicity, as measured by infection types, to these cultivars. Race designations convey information about the pathogenicity of parasite cultures to sets of differential cultivars. Information of parasite genotypes is conveyed only to the extent of one's knowledge of the genetic makeup of the hosts in the differential set. However, genes, not arbitrarily chosen gene combinations, are the functional, segregating units; genes for pathogenicity singly are the inherited units. Thus, a direct method is needed to relate information about genes for pathogenicity in parasite populations to genes for resistance in host plants and about gene association in both organisms.

(2) Information obtained from a pathogenic race designation is

directly applicable only to genes for resistance in a given differential set; thus, we cannot logically conclude that a cultivar of unknown genotype is resistant to all components of a race on the basis of information on one culture of the race. Genes for virulence corresponding to host genes for resistance not found in a differential set can occur within any race determined by that set.

(3) Those using race data must have a thorough knowledge of the race key used in identifying cultures to race in order to gain accurate information from those data. Keys generally have been extensive, asymmetrical, and unwieldy. Usually only those investigators actively working with a given fungus species have adequate knowledge of race keys. Even such specialists are limited by the variation of pathogenicity in the populations that they study.

(4) The greatest value of race designations is their aid in rapid communication. But if inaccurate or incomplete information is conveyed, greater harm may be done than if no information is conveyed (51).

(5) Races, as determined by observing infection types on seedling plants, may be independent of and unrelated to host genes for resistance which are effective only in the adult plant stage. Cultures of any race may have genes for virulence to any one of several genes for adult plant resistance, but the race designation in itself

would not convey that information. Genes for adult plant resistance have been important in breeding cultivars with rust resistance for commercial use. Race data based on infection types on seedlings are inadequate when these genes for resistance are used in plant breeding efforts.

Pathogenic race, then, is a taxon limited in usefulness to the usefulness of the differential cultivar set on which it is identified and to the clarity of information conveyed by citation of a race number. Other means of conveying information concerning pathogenic potential of a fungus population are needed.

Because virulence to corresponding genes for resistance outside a differential set may be independent of race, a system conveying information based on host genes for resistance singly might be more meaningful. Da Silva (16) has vividly pointed this out: "It is easier to breed against 10 genes for pathogenicity than 1,024 races." Unfortunately, our knowledge is incomplete on host genotypes for reaction to rust fungi in cultivars used in studies of pathogenic specialization. At present, in most cases we must use virulence to host cultivars singly as a classification base rather than genes for pathogenicity corresponding to genes for resistance singly. Each cultivar becomes a "set" of one. In a binary system, only one condition need be accounted. Virulence

rather than avirulence would probably be the most useful phenotype (condition) to use in that case, because a low infection type may indicate avirulence or heterozygosity for pathogenicity. Where precise genetic information about differential cultivars is available, frequencies of infection types other than a type 4 may be useful (46). Further, measures of association of virulence may be made when these are useful. J. F. Schafer (personal communication) has shown one method by which this can be done.

Certain associations of genes for virulence undeniably persist and predominate in natural uredial populations. Much circumstantial evidence is available from past studies of pathogenic race distribution and prevalence (25, 28) to indicate the existence of these associations. However, these associations may be either coincidental or due to the screening effect of two or more genes for resistance in one, two, or more widely grown cultivars. Details of population interactions of this kind are lacking. However, until proved otherwise, each corresponding gene pair in host and parasite should be considered to act independently. When host genes for resistance are held constant, the most logical means of classification of parasite cultures is virulence to specific genes for resistance when single cultures are considered, and is virulence

gene frequencies and associations when populations are considered.

To bring order into the systems of studying pathogenic specialization, we must develop host cultivars and parasite cultures of known genetic makeup. In past investigations scientists have attempted to standardize only the host materials used. Long-term preservation of urediospores by liquid nitrogen storage (35) now offers the possibility of standardizing parasite cultures, which in turn can serve to better standardize host materials and can serve as long-term checks for comparison. Obviously, both host and parasite populations are dynamic and cannot be standardized; only the sampling tools can be standardized.

Attempts to artificially stabilize a dynamic system of host: parasite interactions by categorizing a limited part of the variation through race identification have many times concealed or at least not described the important variations present in parasite populations. I think that single host cultivars (host lines carrying single known genes for resistance where possible) should be the focal point for studies of pathogenic specialization. Host cultivars should be placed in sets only for convenience in physical handling. Zadoks (66) has recently described such a system as a future possibility and termed it an "open system" because of the indefinite number of differentials.

With this shift of emphasis away from sets of differential cultivars, even the objectives of studies commonly called "race surveys" could be better conveyed by some

other term. I would suggest "pathogenic potential assays" meaning tests to measure the disease-inducing strength of parasite populations.

PATHOGENIC SPECIALIZATION TO GENES FOR ADULT PLANT RESISTANCE

Genes for adult plant resistance, which are ineffective in the seedling stage of host plant development but useful in protecting later stages, have long been known and have been used extensively in commercial cultivars (13, 31). This type of resistance apparently operates in a gene-for-gene relationship also; the inheritance of certain genes for adult plant resistance is known (18, 39). Specificity has been demonstrated by Bartos, Dyck, and Samborski (5) who experimentally manipulated host and parasite genotypes simultaneously. Dyck, Samborski, and Anderson (18) found that some genes for adult plant resistance were difficult to study genetically because their expression was greatly influenced by light and temperature; my experience with this type of resistance confirms this.

Some investigators consider adult plant resistance to be general rather than specific to parasite genotype. The simple inheritance of certain genes for adult plant resistance and the fact that several cultivars such as 'Ga 1123,' 'Hadden,' 'Kaw,' and 'Ot-

tawa,' all of which previously showed only low infection types in the field in their areas of adaptation, now show high infection types (unpublished data) also strongly indicate that genes for adult plant resistance are as specific as genes for seedling resistance.

Because expression of genes for adult reaction in greenhouse tests are indistinct, the only method presently (1971) available to study the relationship of the genes for pathogenicity and adult plant reaction in naturally occurring populations is the compilation of field reaction data from several locations in a subject geographic area. This method is adequate for many purposes. However, for detailed genetic studies and for studies of association of adult plant reaction with seedling reaction, reliable greenhouse test methods would be desirable.

The system of using virulence to host cultivars as a classification base would be useful in describing variation in pathogenic potential to genes for adult plant resistance as well as to genes for seedling resistance. Indeed,

Zadoks (65) has used "field race" designations of *Puccinia striiformis* West., based on pathogenicity to single cultivars.

No designations of virulence to genes effective in the seedling stage or combinations of such virulence should be used to convey information about virulence

to genes for adult plant resistance unless an association has been shown to exist between these virulences. Without such association, the use of race designations determined by seedling plants to convey information of virulence to adult plant resistance is invalid. Some other system must be used.

BRIEF HISTORY OF STUDIES OF SPECIFICITY IN WHEAT LEAF RUST

Variation in pathogenicity of *Puccinia recondita* f. sp. *tritici* was first described and differential cultivars were prescribed by Mains and Jackson (36) in an abstract in *Phytopathology* in 1921 and more fully in 1926 (37). Eleven cultivars were selected from about 300 that were tested. The cultivars represented "eight differential groups." Three cultivars were soon discarded because of duplication of reaction classes. Johnston and Mains (30) established a set of eight cultivars as a standard set that has been used by many workers. An "International Register" was established and has passed through seven revisions (27) to include races by workers throughout the world.

Chester (15) related the development of pathogenic race studies in *P. recondita* f. sp. *tritici* before about 1940. Those studies centered largely around the standard differentials, their usefulness, and application of data from

them. The cultivar 'Thew' differentiated parasite populations in Australia but not in the United States or Germany (15). Several workers questioned the usefulness of some or all of the cultivars in the standard set established by Johnston and Mains, particularly the cultivars 'Carina,' 'Brevit,' and 'Hussar.' The reactions of these cultivars were extremely sensitive to influence of temperature. Chester (15) proposed that 'Carina,' 'Brevit,' and 'Hussar' be discarded and races be identified on the basis of "groups," using reactions of the remaining five cultivars. Johnston (26) also later proposed this idea and Basile (6) published a key using five of the standard differentials. This key provided a classification basis and a nomenclatural system for identifying races on these differentials. Although the terminology used in that paper is "groups," the requirements are met in the concept of race as used

in this paper. Thus, under my concept, Basile described Unified Numeration (UN) races.

The North American Wheat Leaf Rust Research Workers Committee (1) in 1959 proposed a modification of procedures and nomenclature in race studies of *Puccinia recondita* f. sp. *tritici*. The proposed system included the establishment of a set of supplemental differential cultivars after preliminary study of a series of "Test Varieties." The nomenclatural system proposed the coupling of a standard race number with a supplemental race number consisting of a prefix designating a differential set and a numeral designating a certain combination of reactions on that supplemental differential set. The committee emphasized the need for order in nomenclature and suggested that race designations never be used unless they were based on a published set of differential cultivars. The proposed system implied but did not specifically state the concept of pathogenic race used in this paper; that is, that races may be identified on any published differential set. I would further submit that any such race designation can logically stand alone and necessarily needs no conjunction with other race designations. Williams (63) has apparently independently arrived at the same conclusion. Use of a differential cultivar or set of cultivars should be based solely on its utility in reflecting needed infor-

mation about parasite populations.

The North American Wheat Leaf Rust Research Workers Committee established and published two different sets of supplemental differentials (2, 64) based on studies of a wide range of host and parasite materials. More important to breeding for specific resistance, however, was the establishment of a "Universally Resistant" (UR) series of cultivars, a series of cultivars to which no virulent cultures had been observed in samples from the natural uredial populations of North America. According to Young and Browder (64), the cultivars having "Universal Resistance" to the North America populations were 'Agrus' (C.I. 13228),² 'Aniversario' (C.I. 12578), 'Transfer' (C.I. 13483), 'Lucero' (C.I. 14047), 'Agent' (C.I. 13523), and 'Wanken' (C.I. 13659). 'Agrus' and 'Transfer' have genes for resistance derived from intergeneric crosses (49, 52). Bakshi and Schlehner (4) have shown that the resistance in the *Triticum-Agrophyron* parent of 'Agent' was due to a chromosome substitution of chromosome XVI (3D). The other UR cultivars apparently depend on host gene combinations for

² C.I. refers to the accession number used in the Cereal Crops Research Branch, Plant Science Research Division, Agricultural Research Service, U.S. Department of Agriculture.

their Universal Resistance. Since Young and Browder's report (64), high infection types have been observed on 'Aniversario,' 'Lucero,' and 'Wanken' (unpublished). The remaining UR materials listed in Young and Browder's report constitute the best materials presently available for use in breeding for specific resistance in North America, but they are nevertheless subject to the limitations of the gene-for-gene relationship (33).

Watson and Luig (61) have used another approach to nomenclature of races of *Puccinia recondita* f. sp. *tritici* identified on a supplemental differential set. They have retained the International Standard race system and added the system used in the designation of races of *Phytophthora infestans* (Mont.) dBy. by Black and others (7). In this system, 0 designates a race avirulent to all specified differentials, and the inclusion of a cultivar code number in the race designation denotes virulence to that cultivar. Thus, a designation 1, 2, 5 would indicate a race virulent to cultivars 1, 2, and 5 but avirulent to 3 and 4. This system has the advantage of eliminating need for a key, but such designations would be unwieldy if larger numbers of differentials were used. Further, such a system makes no provision for dropping a differential that becomes outdated because of parasite population shifts.

The inheritance of reaction in the wheat host plant to *P. recondita* f. sp. *tritici* has received considerable attention, dating back to the studies of Mains, Leighty, and Johnston (38). Soliman, Heyne, and Johnston (53) have reviewed the pertinent literature to this area of study and listed named genes for reaction to that time. Under the concepts presented in the present paper, that kind of study is fundamental to fully understanding Host:Parasite specificities. The isolation and naming of genes for reaction is necessary to provide a basis for standardization of pathogenic specialization studies. E. G. Heyne, Agronomy Department, Kansas State University, Manhattan, Kans., coordinates the gene nomenclature for wheat leaf rust reaction and can provide investigators with nonduplicated gene designations. The isolation of known genes for resistance into a host genotype background that carries no other known genes for resistance is another important aspect of this kind of study. Only in this manner can such materials be thoroughly used as standards in specialization studies. Some materials of this kind are presently available in a 'Wichita' winter wheat background from the studies of Johnston and Heyne (29), as well as in a 'Thatcher' spring wheat background from the studies of the Canadian group (17). These are the materials that must be used in order to ade-

quately standardize pathogenic specialization studies. This statement should certainly not be construed to mean that only single gene lines are of value in studying specialization. The status of knowledge at any time, either at present or in the future, dictates that host materials of unknown genotype for reaction be used, because finding and using new genes for resistance and using gene combinations provide hope for specific resistance as a control measure.

The inheritance of pathogenicity in the parasite, *P. recondita* f. sp. *tritici*, has received considerably less attention, but is equally as important as host reaction studies. Samborski (45) and

Samborski and Dyck (47) have published studies of inheritance of pathogenicity, which relate directly to what is known about corresponding genes for reaction in the host.

Nearly all the current work involving the *Triticum:Puccinia recondita* system relates the phenomenon to the gene-for-gene relationship. Although certain relationships probably will not be resolved on such a simple model as that presented in the first section of this paper, it can serve as a basic model. Its use requires more detailed data than those furnished by classic race data portraying combinations of virulences on any specified differential set.

METHODS AND PROCEDURES OF ASSAYING PATHOGENIC POTENTIAL

The methods and procedures used in assaying pathogenic potential of rust fungus populations must vary in order to best provide information to meet varied objectives. In some cases, procedures to meet a specific objective must be used, but usually procedures that will meet several of the objectives at the same time should be used.

The construction of procedures appropriate for making and handling collections of cereal rust fungi to obtain information about populations depends on at least three factors related to objectives: (1) Desired precision of virulence frequency data; (2) de-

sired precision of virulence association data; and (3) desired precision of information concerning distribution of particular virulences.

Procedures may generally be considered in three aspects: sampling, analysis, and data presentation. They will be discussed in that order.

Parasite Population Sampling

The term "population" is used here to mean all individuals of a parasite species within defined bounds. These bounds might be and usually are geographic, but this is not necessary; a specified

population might be bounded by other characters, such as having certain pathogenic potential. Few bounds are really satisfactory to limit populations for study. Political bounds are often poorest technically, but because support usually comes from governments, we therefore are often limited by them. Epidemiological barriers are probably the most generally useful. However, many times other limitations are useful in specifying populations. The bounds of populations studied should be carefully specified when data are presented and should be considered when assay data are applied.

"Sample" is used here to refer to collections of rust fungi on which data are obtained and inferences made about populations. The method of making collections and the use of different analysis procedures profoundly influence the data obtained. Still, these data are the only means of inferring information about the populations. Thus, methods of collection and analysis should be duly considered when inferences are made.

When the objective is measurement of changes in pathogenic potential of a population in time and space, a representative sample from that population is the first requisite for valid results. Representative sampling of rust fungus populations is a complex problem because of the many variables present; it is a problem

that apparently has received little attention.

Sample size required for adequate measurement of gross changes in pathogenic potential is unknown. The effect of using collections from differentially resistant, commercially grown cultivars or from "Universally Susceptible" cultivars is also unknown. Previous sample sizes and sampling techniques have indicated great and rapid changes in pathogenic potential of *P. recondita* f. sp. *tritici* (25, 28) although the degree of accuracy is unknown. However, I have observed that, in most cases, results obtained from the first few collections from an area are studied in a given year tend to set the general trend of results for the rest of the season and early results were often not greatly different from complete results. This observation indicates that a relatively small sample reaches a point of diminishing returns of accuracy for increased sample size. I conclude that relatively small samples should be used to survey pathogenic potential of populations and that greater effort should be made to improve the randomness of these samples. Using a relatively small sample for this purpose would also allow more effort to be made on the detection of new or unusual virulences in parasite populations.

New or unusual virulences can best be detected by using the screening effect of cultivars not

known to be rusted previously or of cultivars with known differential value. Field collections of high infection type pustules on cultivars known to have genes for resistance furnish a powerful tool for increasing the efficiency of sampling when information concerning virulence to particular cultivars is desired. Collections can be made from planned plantings of cultivars of interest; these planned plantings are part of the widely used "uniform rust nursery" procedure. Collections of this kind can also be made at any time by anyone who is particularly interested in a differentially resistant or previously Universally Resistant cultivar. Thus, the plant breeders' nurseries are important sources of such collections. Using rust collections made from cultivars having genes for resistance biases the randomness of the sample. This sampling bias should be considered in subsequent use of data from the collections.

Another sampling method that increases efficiency of detecting new or unusual virulences is the use of composite collections (11, 41) in which urediospores from many locations are composited and analyzed as a single sample. This method, however, obscures detail of virulence distribution. This disadvantage can be overcome to some extent by compositing samples by subunits of the total area studied. Virulence frequency estimates and virulence

association estimates can also be obtained by this sampling method by using appropriate analysis procedures.

Procedures of Analysis

In the past, the desire to make an exact race identification of each collection of *Puccinia recondita* f. sp. *tritici* analyzed has required the use of pure cultures (isolates). This led to development of a subculture system in which urediospores from collections were first used to inoculate differential cultivars or a universally susceptible cultivar; the resulting isolates were grown for one uredial generation, and their spores used to inoculate the differential cultivars. Data were thus obtained on interactions of many isolates with several differential cultivars.

With those data, accurate race identifications could be made. C. O. Johnston (personal communication) arbitrarily set four single pustule isolates from each culture as a standard in his surveys. A methods comparison study (41) has shown that as much variation was usually detected in four isolates as in 20. But subculturing procedures drastically reduce sample size relative to that available in the original culture. As previously indicated, small samples seem adequate for measuring gross changes in pathogenic potential. Use of small samples, however, is not a logical approach when

searching for virulences previously undetected or those known to occur at very low frequencies. To detect such virulences, a random sample sufficiently large to detect the desired virulence frequency level must be made or the sample must be biased by using the "screening" influence of specific host genes for resistance. The latter method seems more feasible in most cases, and cultivars having genes for resistance can be inoculated directly with all the urediospores available from single field collections or with urediospores from composite collections. When samples of *P. recondita* f. sp. *tritici* are so screened through cultivars having genes for resistance, virulence frequencies are difficult to quantify because low infection types are commonly indistinct and difficult to count. Positive virulence detection and its distribution or zero frequency estimates are the extent of data obtainable from these procedures. This screening procedure can be effective by using host lines with genes for resistance to which the parasite populations under study may have widely varying frequencies of virulence if some information is known from previous studies. Also, full detail of the genotype for resistance in a host cultivar is not necessary for gaining much information from such an approach, although when great detail is known for each host cultivar studied, a greater amount

of information about parasite populations under study can be obtained.

The use of known combinations of genes for resistance also has merit for detecting combinations of parasite virulence genes. Genes for resistance that with their corresponding gene for avirulence condition a nonsporulating infection type are more useful in this regard than those that condition sporulating infection types. The isolation of parasite cultures that produce high infection types on a given known combination of genes for resistance assures that those cultures have that combination of corresponding genes for virulence. With further inoculations, these cultures can then be used in determining associations of these virulences with other genes for pathogenicity. Relatively few host lines with known combinations of genes for resistance are available. However, some lines are available in a 'Wichita' background from the work of E. G. Heyne (personal communication). An example of a situation where these lines might be of value would be where an investigator wished to eliminate parasite genotypes having avirulence to host genes *Lr1* and *Lr2* from the sample. Isolation of high infection types on a line having those genes for resistance in combination would effectively eliminate these genotypes, and parasite cultures isolated from a host line having these two genes

for resistance could then be further studied for pathogenicity to some other gene or genes for resistance. When cultures having such combined virulences are frequent, the procedure has less value than when they are infrequent or rare.

Figure 1 presents several alternate procedures that can be used to assay pathogenic potential in parasite populations. In this figure, solid vertical lines represent uredial generations. Broken vertical lines represent inoculations with urediospores. In all cases, the use of several genes for resistance or differential cultivars as a basis for study is assumed. These procedures lead to data of frequency, association, or distributions of pathogenicity to the host materials used as tester lines. Different procedures yield different kinds of data. In many of the procedures, infection type data are obtained and inferences must be made concerning the parasite sample according to Design 2 discussed on page 8. In other procedures, only virulence estimates evidenced by high infection types, relative to a check line, can be obtained. The kinds of data obtained through different procedures are shown below the outline in figure 1.

The procedure of purifying and culturing single field collections on Universal Susceptible cultivars, purifying cultures, and subsequently inoculating differentials

is probably the most widely used procedure for studying differential pathogenicity of *P. recondita* f. sp. *tritici*. Inoculation of Universal Resistant series for virulence detection has recently been widely used (11, 64).

Composite collections have not yet been widely used; some studies have shown that different results can be obtained from composite collections as compared with results from single field collections (11, 41). Handling composite collections may be very similar to handling single field collections, but a larger number of isolates should be used as subsamples for study of differential pathogenicity. The composite collection procedure also efficiently provides a larger parasite sample size for inoculating Universal Resistant host materials. Short-cut methods, based on previously acquired information, can be devised for deriving needed information about parasite populations (11).

The cultivar from which a collection is made directly influences the parasite pathogenicity through its genotype for resistance. There is little indication in the literature that this factor has been adequately considered in assays of pathogenic potential. Sampling techniques and physical analysis procedures must be considered carefully to insure usable data from these studies.

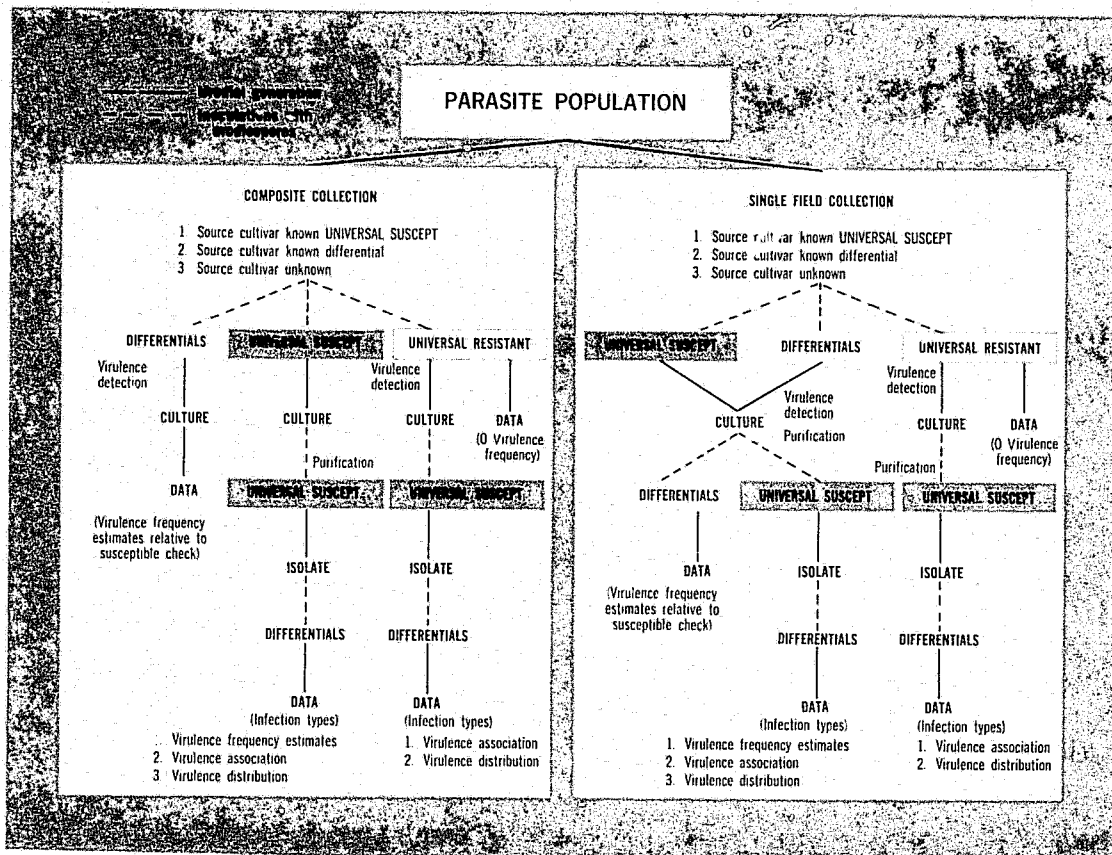

FIGURE 1.—Some alternate procedures used for assay of pathogenic potential in cereal rust fungus populations. Solid vertical lines represent uredial generations; broken vertical lines represent inoculations with urediospores.

Presentation of Data Concerning Pathogenic Potential

This is probably the most difficult of the various phases of pathogenic specialization studies. The classic means of presenting data as frequencies and distributions of pathogenic races is indirect, concerning pathogenicity to individual differential cultivars in the set used; that means also encourages the unwarranted extrapolation discussed earlier. Yet the concept of race identification is very strong in the minds of plant scientists working with pathogenic specialization. A clearer understanding of the limitations of presenting data as races is necessary for further progress.

Race designations take into account only combinations of virulences based upon the entire set used in making the race designation. They do not readily portray information concerning virulence either to single differentials in the set or combinations of virulence to sets of differentials less than the complete set. For example, UN races 5, 9, and 13 of *P. recondita* f. sp. *tritici* (6), which presently are common in the North American population of *P. recondita* f. sp. *tritici*, all indicate virulence to *Lr1* in 'Malakof'; the frequencies of these and others so virulent must be added to obtain an estimate of virulence frequency to *Lr1*. Likewise, cultures of UN races 9 and 13 are viru-

lent to both *Lr1* and *Lr2* and their frequencies must be added together to obtain information of frequency of association of genes for virulences corresponding to these two genes for resistance. This information is more directly available in the original infection type data before race identifications are made. Because host genes for reaction and parasite genes for pathogenicity are the functional units in the Host:Parasite system, these should provide the basis for presentation of information. When more than five or six cultivars are used and races are identified, and when attempts are made to convert race data to frequency of virulence to single cultivars or genes for resistance, the data become unmanageable by hand methods. The data can be more easily managed as infection-type data.

J. F. Schafer (personal communication) has proposed a method of analysis of pathogenic specialization data using Chi Square tests for independence of two or more host lines in paired comparisons. This procedure results in hypotheses of genetic relationships of differential cultivars. Although he used race data, the general method should be applicable to infection type data. Schafer's method can also be used to detect and present associations of pathogenicity in parasite populations when host lines with known genes for resistance are used as differentials.

The presentation of pathogenic specialization data as frequencies of virulence and as associations of virulence should re-

place presentation of race data.

Computerization of pathogenic specialization data handling systems should increase efficiency.

EQUIPMENT DEVELOPMENT

The assay of pathogenic potential in a parasite population depends upon the inoculation of numerous host cultivars with cultures representing the particular population. Many cultures are usually necessary to adequately describe populations. Need for speed and accuracy in planting and growing necessary plants, purifying cultures, and inoculating plants, as well as need for space efficiency, led to the development of several pieces of equipment. Some were modified designs from previous equipment; some are new. They are described below.

Mechanized "Differential Set" Seeder

An electrically powered mechanized seeder was designed and built, based on principles used by H. C. Young, Jr., (personal communication) for a manually operated seeder. The seeder developed is shown in figures 2 through 6. Figure 2 is a general view. A single set of differential cultivars was planted in approximately 3 seconds by placing a pot filled with sandy loam soil in position under a pneumatically powered punch press, actuating the press

by a foot switch, then moving the pot to a position under seed-dropping tubes on the seeder and actuating the seeding mechanism by another foot switch (fig. 3, *A, B, C, D,* and *E*). The resulting planting is shown in figure 3, *F*. Discreteness of cultivars within the pot was maintained by this method.

The increasing number of test cultivars necessary to adequately assay the pathogenic potential of the North American population of *P. recondita* f. sp. *tritici* has resulted in a modification of classification systems (1) and the establishment of several different sets of wheat cultivars to be used. Thus, the seeder was designed to plant sets of 1, 5, 9, 16, or 30 cultivars in various size containers by interchanging the seed reservoir plates and the dropping tubes (fig. 4, *A* and *B*). Figure 4, *C* shows, *left to right*, sets of 1, 5, 9, 16, and 30 cultivars. Seed reservoirs were closed by turning each a quarter turn on the reservoir plate. Plastic pots or aluminum pans were used exclusively to provide container uniformity.

The seeder was powered by a 1/8-hp. electric gearmotor (fig. 5, *A*) to drive the seed-dropping

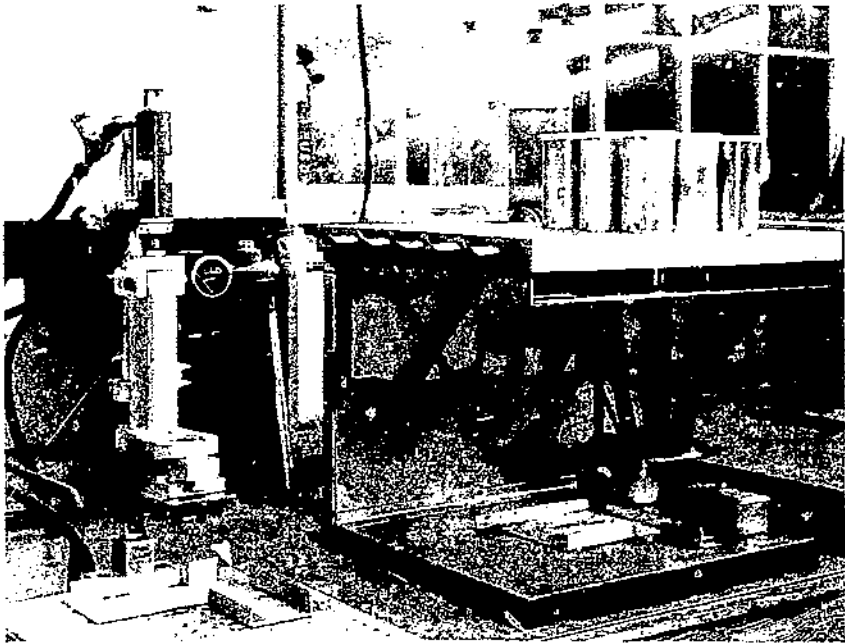

PN-2080

FIGURE 2.—General view of a mechanized seeder for planting sets of differential cultivars.

shafts through a single revolution clutch (*upper arrow*) controlled by a solenoid-powered lever (*lower arrow*) and through a series of matched gears (fig. 5, *B*). Figure 6 shows construction detail of the seed-dropping mechanism. The gearmotor operated at 120 r.p.m.; about 1 second was required for planting each set after the holes were punched for the seeds.

A combination of top and bottom watering was used. For bottom watering the pots were placed in fiber glass cafeteria trays and flooding the trays as needed. One watering at planting time was usually sufficient to result in seedling emergence.

Cyclone Spore Collector

The cyclone spore collector principle described by Tervet and others (60) provided the most efficient means of collecting urediospores where many relatively small cultures were handled individually.

A collector using that principle was developed with some modifications from previous models. The collector developed used a 00 gelatin capsule as a urediospore receptacle, with the capsule fitting into a tapered hole rather than over a flange as in previous models. The chief modification was that of using a quick-connect friction joint (fig. 7, *A* and *B*) to facilitate handling

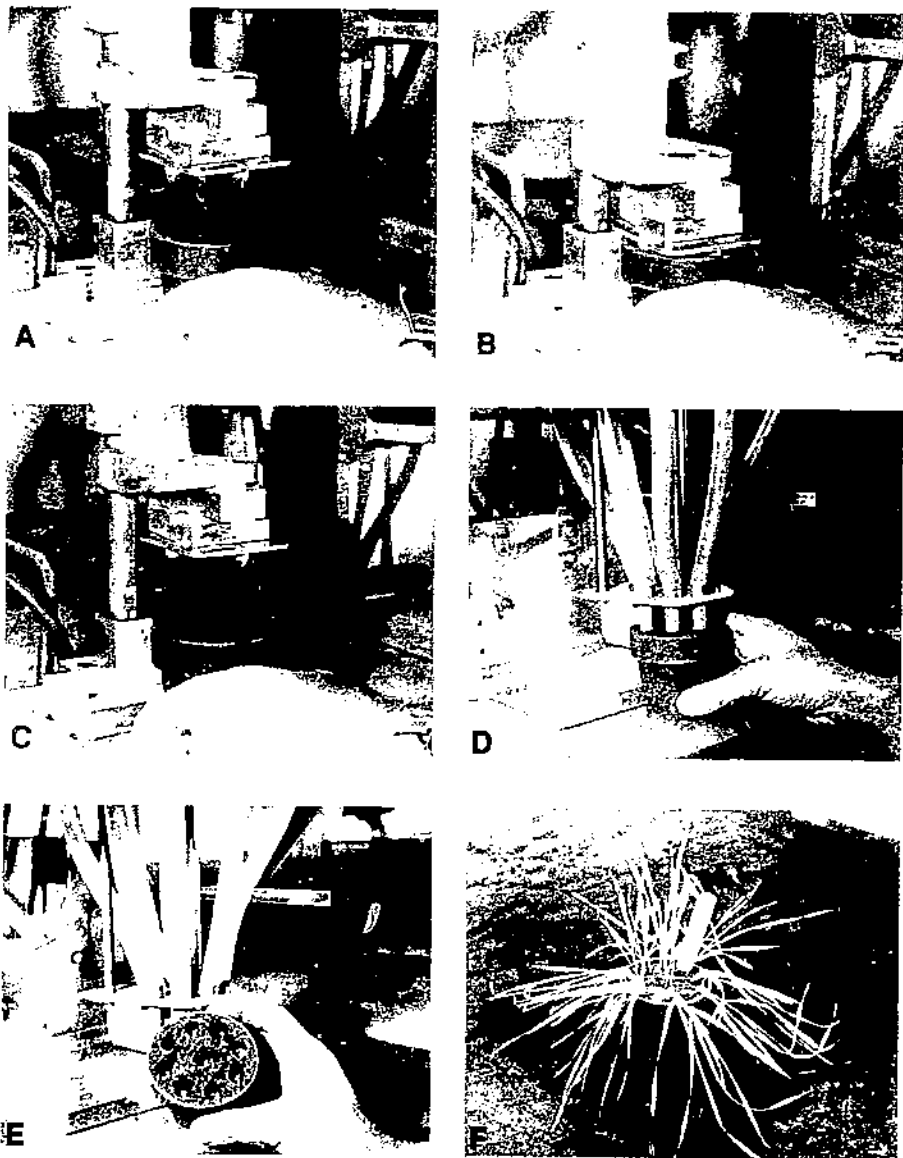

PN 2081, PN 2082, PN 2083, PN 2084, PN 2085, PN 2086

FIGURE 3. Planting a single set of differential cultivars: *A*, Plastic pot, filled with soil and placed in position on punch press; *B*, punching head shown in down position during punch operation; *C*, punching head in up position immediately after punch operation; *D*, pot with holes punched in soil and placed in position for seeding operation; *E*, pot with seeds sown in soil immediately after planting; *F*, differential cultivars set resulting from planting operation shown in *A* through *E*. Note discreteness of cultivars within pot.



PN 2987, PN 2988, PN 2989

FIGURE 4. Planting several sets of differential cultivars: A, Top front view of seeder with 9 cultivar set seed reservoir and dropping tubes; B, top front view of seeder with 30 cultivar set seed reservoirs and dropping tubes; C, plant containers with seedlings (left to right) of 1, 5, 9, 16, and 30 cultivar sets grown to proper stage for inoculation.

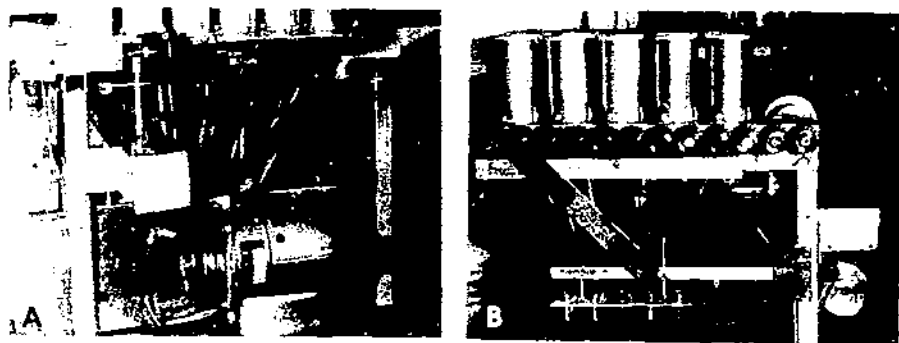

PN 2990, PN 2991

FIGURE 5. A, Rear view of seeder showing gearmotor, single revolution clutch (upper arrow), and solenoid controlled lever (lower arrow); B, right side view of seeder (with protective cover removed) showing gear series used to transmit power to seed-dropping shaft.

large numbers of cultures. Figure 7, C shows the collector in use. The urediospores were collected either dry or directly into carrier oil. The capsules were labeled by writing directly on them with

plastic black drawing ink. The urediospores within capsules were conveniently stored in a refrigerator in a board with holes drilled to hold the capsules upright.

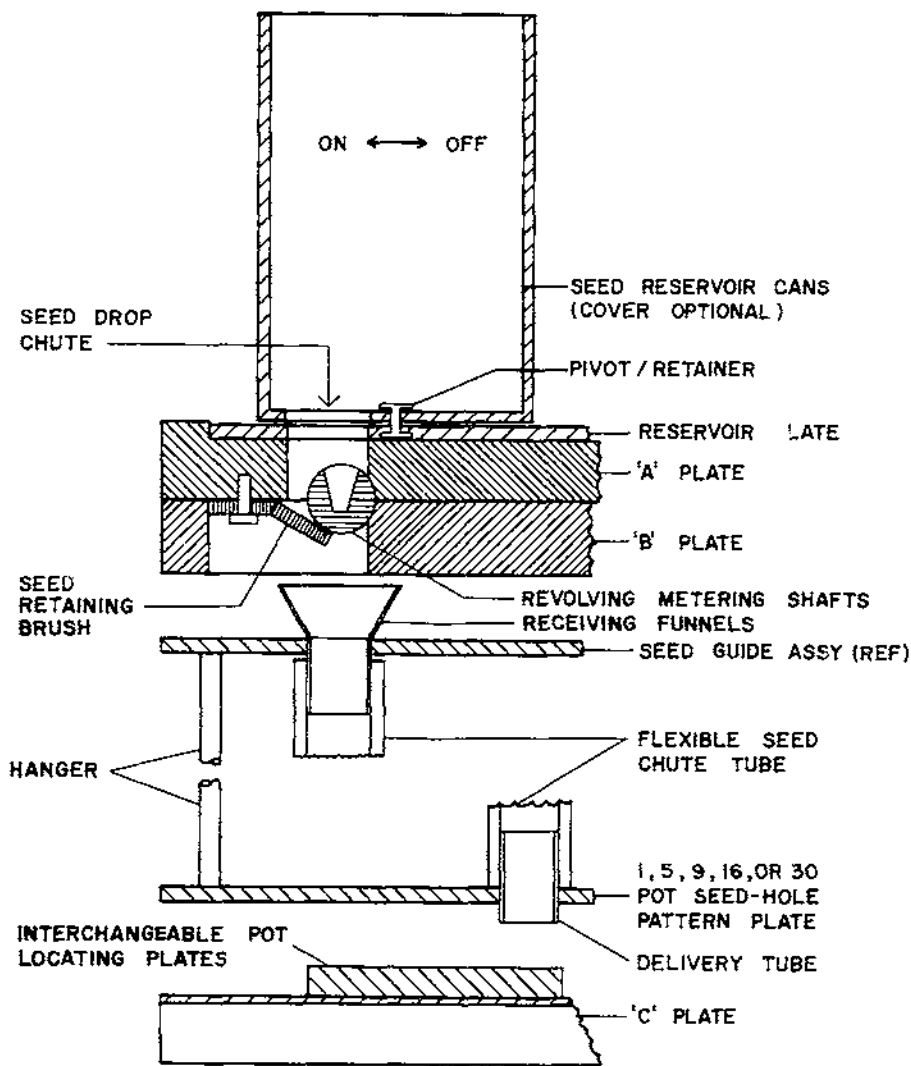
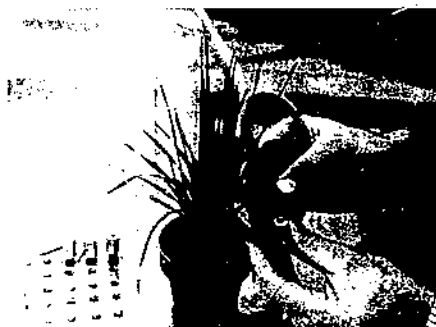
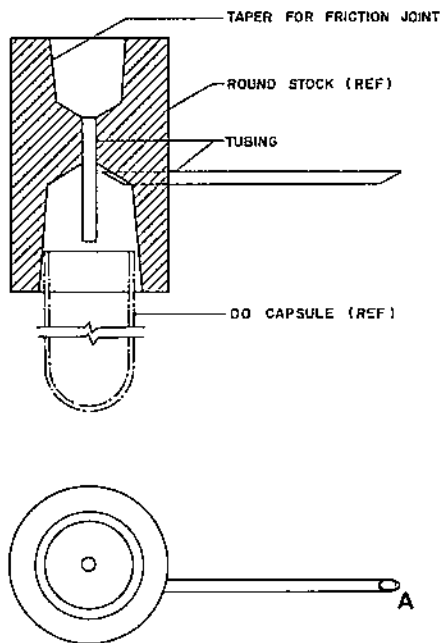

FIGURE 6.—Cross-section schematic diagram showing construction detail of a single seed-dropping mechanism used in the seeder.



PN-2092, PN-2093

FIGURE 7.—Cyclone spore collector: A, Construction detail of collector modified for rapid connect-disconnect to suction source (top, cross-section view; bottom, bottom view of collector); B, view of collector showing suction tube connecting operation; C, collector in use.

Plastic Isolation Cage

The handling of large numbers of cultures of different or unknown identity required isolation of some type. A clear plastic cage to fit 3-inch plastic pots was developed to effectively isolate cultures during increase. The cage is shown in figure 8, A with construction detail outlined in figure 8, B. Care was taken to obtain a nonphytotoxic material for making the cages and Eastman, Spec. 530-E-37200, MN Clear Butyrate plastic was satisfactory. Isolation was not absolute but was suffi-

cient to maintain an acceptable purity level.

The use of growth-retarding (2 chloroethyl) trimethylammonium chloride (24) prolonged plant life and facilitated handling of caged cultures.

Spore-Oil Suspension Atomizer

Rowell (42) described the use of nonphytotoxic isoparafinnic oil as a carrier for urediospores of *P. graminis* f. sp. *tritici*. This method is applicable to inoculating with *P. recondita* f. sp. *tritici* and was used in many cases when

bulk urediospores were used as inoculum. The carrier oil California Spray Chemical Corporation SOS-B, mixed in equal parts with light-weight mineral oil (44), was a satisfactory carrier in inoculating seedling wheat plants with urediospores of *P. recondita* f. sp. *tritici*. A compact, sturdy atomizer was designed and constructed to facilitate inoculation with large numbers of cultures. The atomizer was a design modification of that described previously (10); the operating principle and the critical dimensions of barrel diameter and liquid delivery tube to barrel end were unchanged. The atomizer is shown in figure 9, A with construction detail shown in figure 9, B. This design permitted economical manufacture of the atomizers. The atomizer was also adapted using a 22-ml. vial suspension reservoir (fig. 9, C).

Automated Inoculation Booth

An inoculation booth was designed and constructed to facilitate inoculations. It contained an automatically controlled turntable, a solenoid valve-controlled compressed air outlet with a friction joint fitting matching the air intake fitting of the atomizer, and a solenoid valve-controlled tap-water mist spray system. A general view of the booth is shown in figure 10, A; it was constructed to facilitate spore-oil suspension inoculations and brush inocula-

tions and to wet plants to be inoculated by the spatula method. Figure 10, B shows the timing mechanism and manual override switches used to produce various cycles desired. A grating floor for use in making brush inoculations was hinged at the back to permit its easy removal from the turntable area during inoculation with urediospore-oil suspensions.

To make a urediospore-oil suspension inoculation of a differential set or other cultivar set, workers placed the potted plants on a turntable designed to accommodate any of several plant containers (fig. 10, C), closed the front sliding door, placed the loaded atomizer on the compressed air fitting, aimed it at the plants (fig. 10, D), and actuated the timing mechanism by pressing a waterproof electrical foot switch. The timing mechanism in turn started the turntable at 100 r.p.m., opened the air outlet for 2 seconds, closed it, provided a 2-second lag, opened the mist spray system for 18 seconds, then automatically turned off until actuated again. The 2 seconds of air at 20 p.s.i. and the 2-second lag provided sufficient time for atomization of 0.1 ml. of urediospore-oil suspension over the plants. The mist spray served both to wet the inoculated plants and to precipitate excess urediospores from the booth. After the cycle was complete, the front door was opened and the plants were removed to a

tray and then transferred to a moist chamber. Inoculum was prepared during the 18-second mist spray; thus little more than the 22-second cycle was required for a single inoculation. Sufficient numbers of atomizers described above were available to inoculate with up to 200 cultures (1 atomizer per culture) without cleaning the atomizers. This procedure saved time during inoculation; the atomizers as a group were easily cleaned by pouring acetone over them in a pan and then pouring the acetone back into a storage bottle.

Urediospore-oil suspensions were used to inoculate the Universally Resistant series of cultivars and a Universally Suscep-

tible variety with spores collected from densely infected dried leaf collections and to inoculate differential sets with spores from single-pustle isolates.

The timing mechanism on the inoculation booth could also be set to reproduce a continuous cycling of 12 seconds of water mist spray and 10 seconds off. This allowed brush inoculation of plants while the mist spray was off; the mist then moistened the plants and precipitated excess urediospores from the air in the inoculating booth. The 12-second mist spray also allowed time to move inoculated plants from the inoculation booth to a bench or moist chamber, dispose of the plants bearing inoculum, and prepare for the next inoculation.

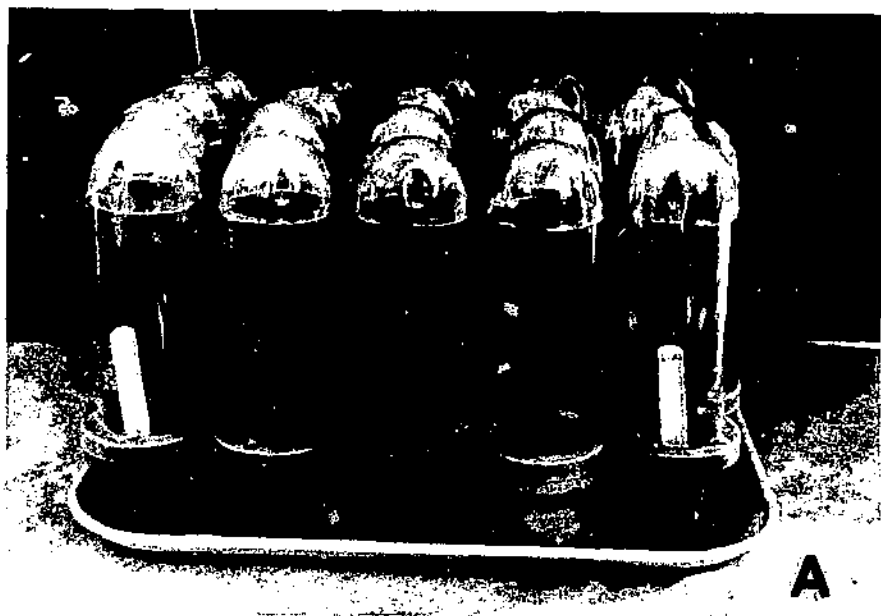

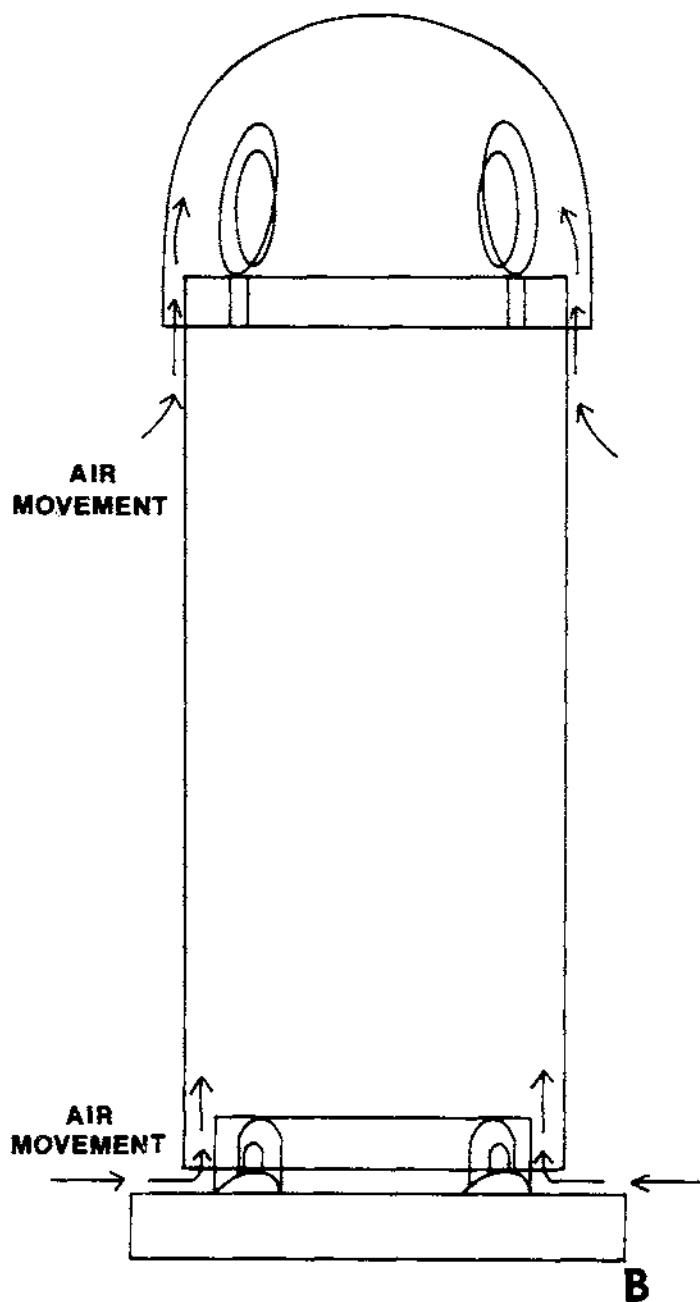
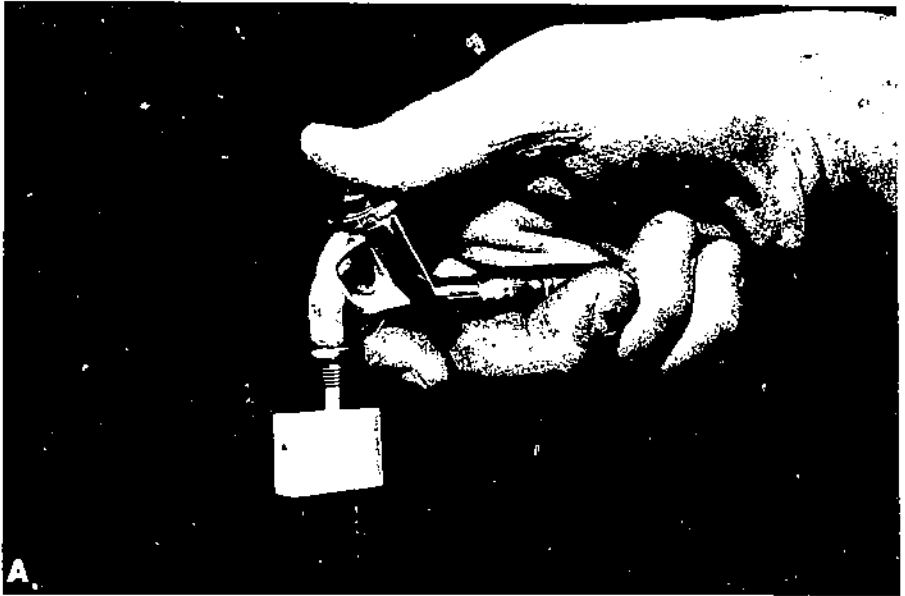
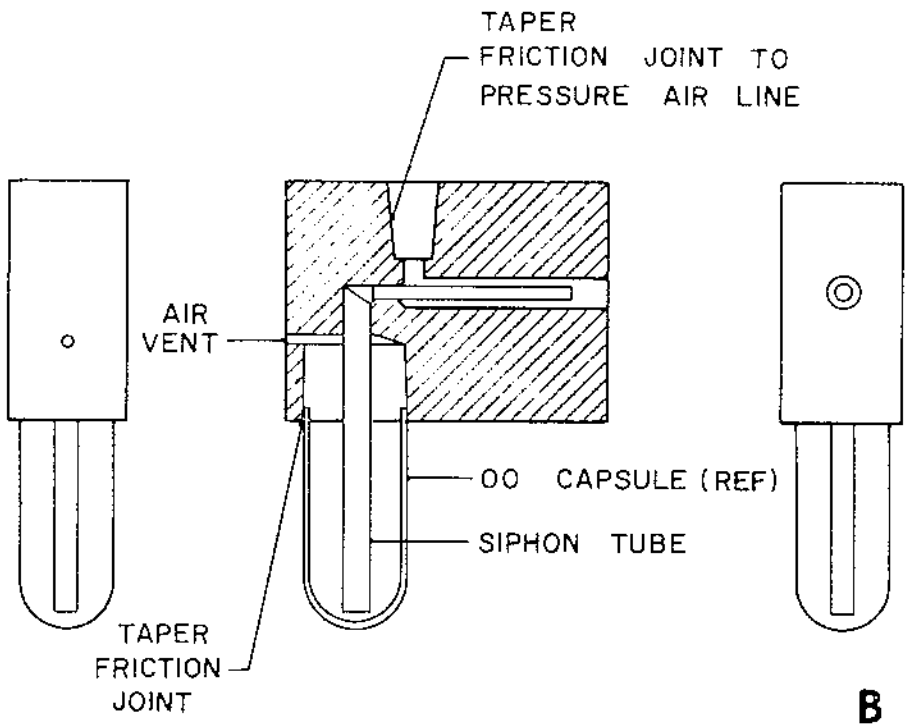

FIGURE 8.—Plastic isolation cage: A, Cultures of *P. recondita* f. sp. *tritici* protected by plastic isolation cages and placed in cafeteria trays to facilitate watering; B, construction detail of a plastic isolation cage developed to prevent cross contaminations between cultures of *P. recondita* f. sp. *tritici*.



PN-2095



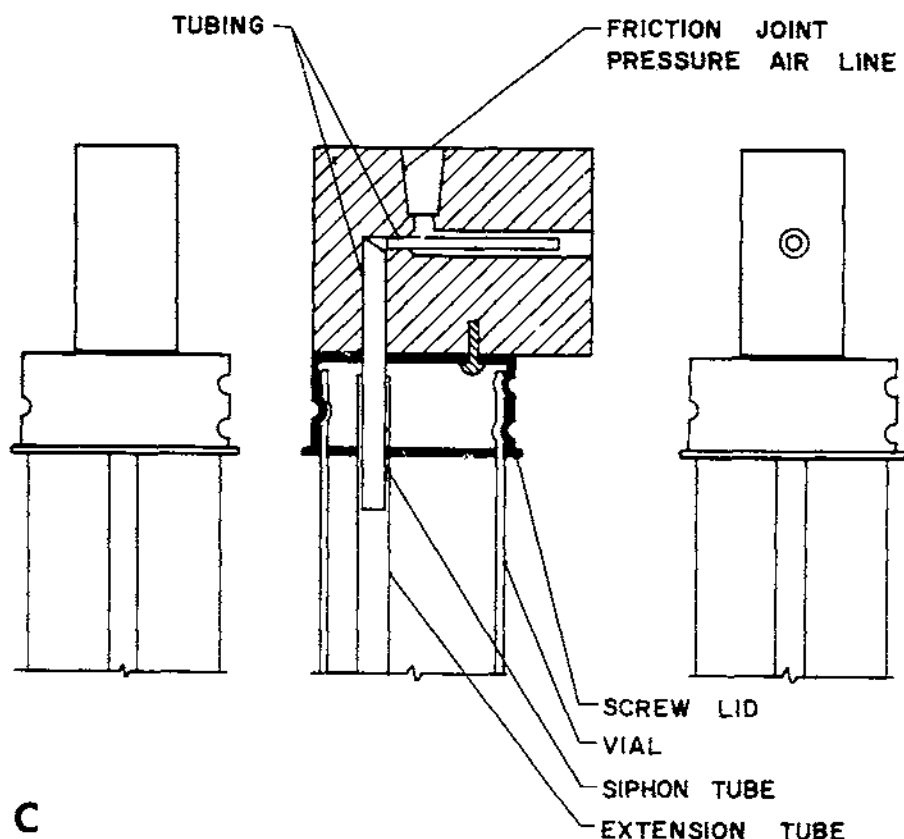

FIGURE 9.—Spore-oil suspension atomizer: *A*, Atomizer attached to an air cutoff valve; *B*, construction detail of atomizer for use with 00 gelatin capsule reservoirs (*left*, back view; *center*, cross-section view; *right*, front view); *C*, construction detail of atomizer adapted to use a 22-ml. glass vial reservoir (*left*, rear view; *center*, cross-section view; *right*, front view).

Refrigerated Cabinet-Type Moist Chamber

Ingress by *P. recondita* f. sp. *tritici* occurs in 12 to 16 hours in the presence of free moisture at 15° to 20° C. (15). A refrigerated cabinet-type moist chamber of stainless steel (fig. 11) with cooling coils embedded between double walls was constructed to provide the temperatures re-

quired because greenhouse temperatures fluctuate much beyond that range. Free moisture was provided by mechanical atomization of tapwater over the inoculated plants. Using cafeteria trays for holding potted plants (figs. 8, *A* and 11) greatly reduced handling time required for moving plants during the various phases of analysis without contaminating the cultures.



PN 2096, PN 2097, PN 2098, PN 2099
 FIGURE 10.—Automated inoculation booth: *A*, Front general view of booth; *B*, cam programmed timer (*left*) and manual over-ride switches (*right*) used to produce various cycles of turntable operation, air, and mist within automated inoculation booth; *C*, inoculation booth turntable with potted plants in position for inoculation; *D*, compressed air head of inoculation booth with loaded spore-oil suspension atomizer in place.



PN 2100

FIGURE 11. Refrigerated moist chamber filled with inoculated and moistened plants.

COMPENDIUM OF TECHNIQUES USEFUL IN CULTURING *Puccinia recondita* F. SP. *TRITICI*

Culturing the uredial stage of *P. recondita* f. sp. *tritici* on wheat is relatively easy compared with culturing other wheat rust fungi because of its intermediate and relatively wide range of environmental adaptation. Many techniques regularly used are briefly described below, with some modifications that increase efficiency when large numbers of uredial cultures are handled simultaneously.

Urediospore Increase

Single Urediospore Isolation and Culture

The "goose hair technique" of Guthrie (1931), coupled with a detached leaf technique, has been very useful in making and increasing single urediospore cultures. Detached leaf culture is used to make the first uredial generation increase from single urediospores. The urediospores produced from that generation

are then used to inoculate whole plants grown in isolation and thus to produce amounts of spores necessary for storage and subsequent standardization of cultures of the rust organism.

"Screening" Host Cultivars

For Urediospore Increase

The elimination of parasite genotypes having avirulence to certain host genes for resistance from mixed cultures of *P. recondita* f. sp. *tritici* when the culture is grown on a cultivar carrying those genes for resistance provides a useful technique for maintaining acceptable purity in different parasite materials grown in close proximity in the greenhouse.

The technique is applicable only when parasite avirulence and host resistance effect a nonsporulating infection type. It requires only the manipulation of host cultivars and parasite cultures so that each parasite culture has virulence to all the genes for resistance of the host cultivar and so that the host cultivar has effective resistance against as many other nearby cultures as possible. A simple example of such a system would be matching cultivars and cultures having the following genotypes when the three cultures must be grown in the same general area:

Under such a system of maintaining cultures, the genes for resistance in each cultivar eliminate one or both the remaining culture genotypes and permit normal sporulation of the indicated culture. Complete elimination systems cannot usually be devised. Partial control of contamination by this technique is possible. Similar systems can often be manipulated with wide ranges of materials when suitable combinations of genes for resistance in different host cultivars are available.

Urediospore Collection

In studying pathogenic specialization, we need to collect urediospores both as samples from wheatfields or plots and from cultures growing in the greenhouse or other artificial environment. The three techniques I use for urediospore collection are the dried leaf collection, the leaf tap collection, and cyclone collector.

Dried Leaf Collection

This is the simplest technique for urediospore collection and requires no special equipment. It is commonly used, but certain important points should be emphasized to make collections of most value and to facilitate later handling. The technique is used chiefly for field collections and con-

	Culture			Cultivar		
(1)	PLr1	Plr2	pLr3	(1)	lr1	lr2 Lr3
(2)	pLr1	PLr2	pLr3	(2)	Lr1	lr2 Lr3
(3)	pLr1	pLr2	PLr3	(3)	Lr1	Lr2 lr3

sists simply of clipping or pulling rusted leaves, placing them in glassine envelopes, and recording appropriate information about the collection. To facilitate handling the collection, the leaves should be placed in an envelope, pressed, and thoroughly dried before they are further handled or mailed. No more than 6 to 8 leaves should be placed in a single envelope so that the amount of moisture will be reduced and pressing made easier. Leaf collections will usually dry adequately in 24 hours at room temperatures. Care should be taken not to expose the collections to extremely high temperatures at any time. Dried leaf collections can also be used to collect urediospores from greenhouse cultures, but other methods are usually more satisfactory.

Leaf Tap Collection

In this technique for urediospore collection, heavily rusted materials are tapped with a rod while they are held over a funnel, wax paper, foil, or other container. The urediospores can then be collected by gravity into storage vials. This technique is useful where large amounts of urediospores in bulk form are to be collected and a high level of purity need not be maintained, as in collecting spores from cultures in the greenhouse to use in field inoculations. The technique has the advantage of requiring relatively little equipment.

Cyclone Collector

This technique for urediospore collection has been discussed briefly in connection with development of a new model of the cyclone collector. The technique uses the principle of particle collection first described for urediospore collection by Tervet and others (60). Many models of the cyclone collector are available, including one for collecting large amounts of urediospores (14) and two for collecting urediospores into vials made from 5-mm. borosilicate glass tubing (12, 32). In each model, urediospores are impacted in the bottom of containers because of the loss of velocity from downward cyclonic movement. The technique requires special collectors and a suction source. It offers the advantage of having the urediospores "containerized" immediately after collection, thus reducing handling time and risk of contamination. The technique is useful both in handling small individual cultures and in collecting bulk urediospore lots because different collector models are available. I have used the suction from the manifold of the engine of a truck for a suction source for collecting spores in the field (9).

Bulk urediospores should be dried before they are placed in storage. Exposure for 24 hours at room temperature and moderate relative humidity is usually sufficient to dry urediospores.

Urediospore Preservation

Study of *Puccinia recondita* f. sp. *tritici* often requires storage of urediospores for varying time periods. There are three techniques in common use for this purpose.

Refrigerator Storage

Urediospore longevity in *P. recondita* f. sp. *tritici* is generally adequate to permit culture storage up to 4 or 5 months under refrigeration at about 5° C. and moderate relative humidity. However, some viability may be lost. This technique has been most commonly used for storing dried leaf collections during the interval between receipt and culturing. Long-term preservation requires other means of storage.

Vacuum Dry Storage

This technique of urediospore preservation was developed by Sharp and Smith (50). Longevity is increased considerably over spores stored in a refrigerator without vacuum drying. Preservation is due to drying by sublimation effected by reducing pressure in a closed system. The spore containers are then sealed under reduced pressure and stored at refrigerator temperatures. Slow rehydration is required before inoculation (42). Some special equipment is required and results are somewhat erratic. The technique represents considerable improvement over refrigeration storage, but is less convenient and less satisfactory than liquid nitrogen storage.

Liquid Nitrogen Storage

Loegering, Harmon, and Clark (35) described a technique of storing urediospores of *P. graminis* f. sp. *tritici* sealed in borosilicate glass vials by immersing the vials continuously in liquid nitrogen at -196° C.

Treatment at about 40° C. is required after storage to break a cold-induced dormancy of the urediospores (35). This technique of storage, when properly used, maintains viability and infectivity. Long-term tests have been conducted for 5 years (34) with no appreciable loss of viability. Detailed information concerning procedures and safety have been given (35). The technique is fully applicable to *P. recondita* f. sp. *tritici* and is used routinely by the author. All parasite cultures are not necessarily alike in "heat shock" requirement. Tests with cultures of *P. recondita* f. sp. *tritici* also show some variation for this requirement; however, a 40° heat shock has not been shown to be detrimental and therefore should be used for all cultures unless heat shock requirements for a specific culture are known. The system of culture retrieval from liquid nitrogen described by Leath, Romig, and Rowell (32) was used. Equipment and replenishment of liquid nitrogen for this storage technique is considerably expensive, but the advantages of assurance of long-term urediospore viability and increased efficiency of handling cul-

tures easily outweigh that disadvantage when large numbers of cultures are to be maintained.

Inoculation With Urediospores

Inoculation with *P. recondita* f. sp. *tritici* urediospores is simply the placement of spores on the wheat leaf infection court. However, because of the great differences in quantity of inoculum available, kind and number of plants to be inoculated, and objectives of inoculation, many different inoculation techniques have been developed. Some of these techniques and their use are described.

"Spatula-Slide" Inoculation

This technique is useful in inoculating plants with urediospores taken from dried leaf collections or from single pustules on living plants when purifying cultures. It is a modification of the commonly used spatula technique (30). The seedling plants to be inoculated should be prepared before inoculation either by rubbing them lightly between moistened index and second fingers or by spraying them lightly with nonphytotoxic oil, then with water. Groups of plants for inoculation can be prepared and placed in a protected area before beginning inoculation.

Urediospores are first transferred from the source leaf to a small droplet of water on a 25-by 75-mm. glass microscope slide

with the moistened tip of a small sterile spatula (fig. 12, A). The spores are then distributed over the water surface by vigorously stirring with the spatula tip (fig. 12, B). Spores are then placed on the moistened seedling by wiping the water droplet over the leaf surface (fig. 12, C), using finger or thumb to hold the leaves against the slide. Care must be taken to avoid injury to the leaf. Hands and spatula must be cleaned before each inoculation. Immersion of the spatula tip in acetone sterilizes it satisfactorily. Rapid drying of acetone is useful because flame is not necessary to dry the spatula. Do not handle acetone around flame. The fingers may be cleaned with acetone between inoculations.

In a useful modification of this technique, two operators work together to increase efficiency when large numbers of cultures are to be handled. One person can transfer the spores with the spatula from the source pustule to the water droplet and pass the slide to the second person, who then transfers the spores from the water droplet to the plant leaves. In this procedure, the spatula operator does not need to clean his hands between inoculations; he must clean only the spatula tip because it is the only surface that touches the urediospores. The slide operator must clean his fingers before each inoculation because they touch the spores and

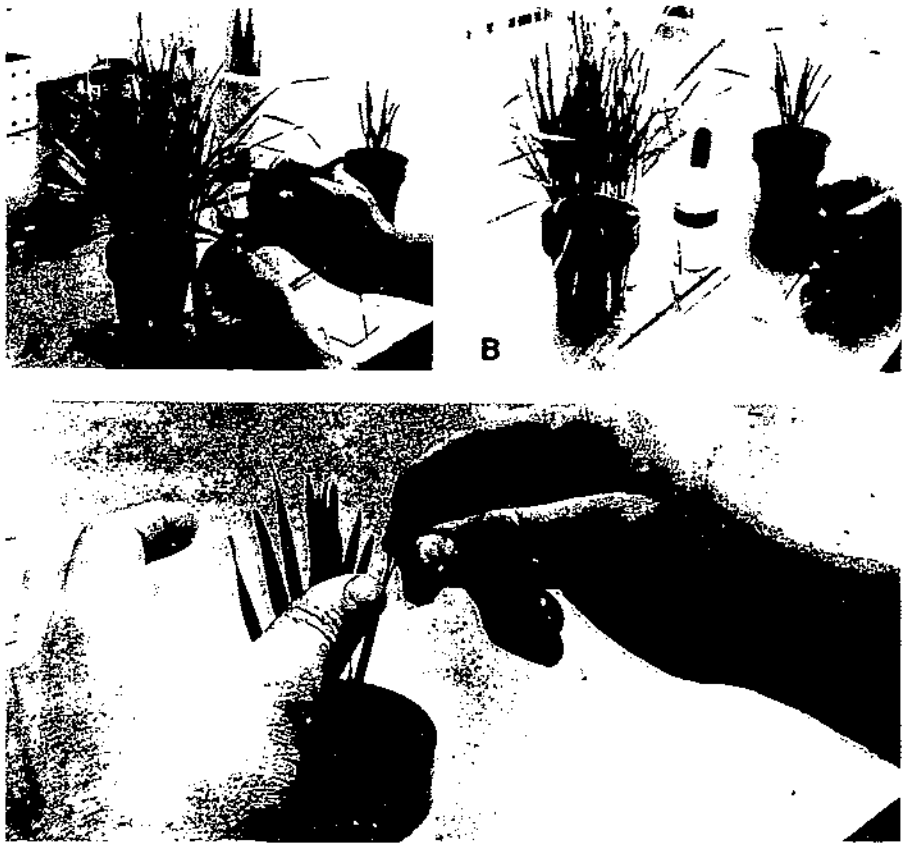

PN-2101, PN-2102, PN-2103

FIGURE 12.—“Spatula-slide” inoculation technique: *A*, Removal of urediospores from pustule with spatula; *B*, placement of urediospores into water droplet on glass microscope slide; *C*, placement of urediospores onto wheat leaf surface from slide.

leaf surface in each inoculation. Culture identity can easily be maintained by visually and orally verifying labeling.

The glass slides used in this technique can be reused, sterilized by heat, and used again without thorough cleaning; sterilization is the main concern.

I have used this technique exclusively for single-pustule isolation and also to some extent for

starting cultures from urediospore collections.

“Dip” Inoculation

This is a convenient technique for starting cultures with small quantities of bulk urediospore inoculum when increasing spores for further use (H. C. Young, Jr., personal communication).

Urediospores are floated on the surface of water in a 600-ml. beaker or in a disposable cup. Potted seedling plants to be inocu-

lated are first prepared by lightly rubbing the moistened leaf surface, inverting the pots, and dipping the leaves into the spore suspension (fig. 13). Urediospores cling to the leaves as they are pulled out of the water. The plants are then atomized with tapwater and placed in a moist chamber. This is an easy, rapid technique for inoculating small numbers of plants when limited quantities of urediospores are available in bulk form.

"Brush" Inoculation

When urediospores of an actively sporulating culture on seedling plants are to be used as inoculum, the brush technique is

usually preferred. The plants are first prepared by rubbing the moistened leaves lightly between clean, moistened fingers or by spraying lightly with a clean carrier oil such as SOS-B (fig. 14, A). The plants are again moistened and placed in an area where they are to be inoculated. Inoculation is then made by inverting the pots containing the sporulating cultures over the plants to be inoculated and lightly brushing them together (fig. 14, B). Inoculated plants are again moistened and placed in a moist chamber for the penetration period. This technique was used routinely for inoculating both



PN-2104

FIGURE 13.—"Dip" inoculation technique: Wheat leaves dipped into water with urediospores floating on surface.

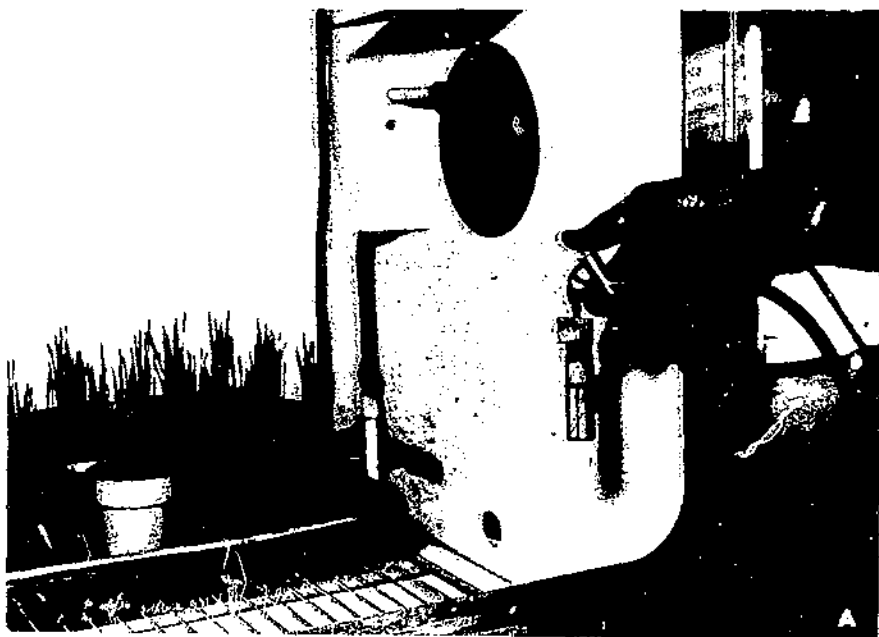

PN-2105, PN-2166
FIGURE 14.—“Brush” inoculation technique: *A*, Wheat plants in inoculation booth, being sprayed with clean SOS-B oil in preparation for inoculation; *B*, uninfected plants brushed with plants having actively sporulating pustules.

test plants in pathogenicity studies and plants for urediospore increase.

"Oil-Spore Suspension"

Inoculation

This technique was developed by Rowell (42) for *Puccinia graminis* f. sp. *tritici*, but is useful in many cases for *Puccinia recondita* f. sp. *tritici*.

Atomizers for applying oil-spore suspensions have been described in this paper and elsewhere (10). The technique is easily used with one precaution; application of the carrier oils to leaves must be minimal. If too much oil is applied, phytotoxicity to both host and parasite results.

With practice, however, this problem is easily overcome.

Inoculations consist of spraying the urediospore-oil suspensions lightly over the plants to be inoculated. Urediospore concentration of the suspension may vary with the desired infection density or the quantity of urediospores available, or both. The oil film acts as a surface tension depressant and the inoculated plants are easily moistened sufficiently for infection to occur. This technique is useful in inoculating test plants with urediospores compositated from several field collections or with purified cultures that have been stored.

APPLICATION OF KNOWLEDGE OF PATHOGENIC SPECIALIZATION TO DISEASE CONTROL

The remaining potential value in using specific genes for resistance in control of cereal rusts lies in either one or both of two approaches: (1) Rapid manipulation of host materials to remain one step beyond the prevailing pathogenic potential of the parasite or (2) man's ability to establish combinations of genes for resistance in his host materials, which in some way will decrease the probability of a given parasite's overcoming that resistance. Both approaches may be possible with increased knowledge of Host:Parasite specificity, improved methods of studying parasite populations, and improved breeding techniques. Some of the

possibilities suggested by others would be aided by more thorough knowledge of pathogenic specialization and are discussed below.

In its disease control aspects, the multiline or composite cultivar approach of Borlaug (8) depends heavily upon knowledge of the pathogenic potential of parasite populations affecting the multiline cultivars grown. This approach uses lines carrying single genes for resistance in composites, which, as a whole, protect against most or all of the parasite population present. Information presented directly in terms of pathogenicity to these genes for resistance should be much more meaningful than in-

formation presented indirectly as race data.

A direct method of presenting data would also be useful for simple combinations of genes for resistance in commercial cultivars providing adequate protection in a single genotype of the host.

The combination of two or more Universally Resistant genes would perhaps be useful in protecting commercial cultivars for longer periods than has previously been possible using only one such gene in a cultivar (48). Such genes for resistance can be combined for commercial use in more than one way. They can be combined by conventional breeding techniques with a test crossing program as outlined by Athwal (3). However, the combination of genes in this manner, in addition to need for other characters in modern cultivars, makes this impractical at present (1971). Differences in characteristic low infection types resulting from interaction of different corresponding gene pairs have been proposed to overcome the tedious test crossing procedure (48).

The rapid manipulation of combinations of genes for resis-

tance into and out of commercial production through wheat hybrid breeding techniques presently is the most promising procedure. The use of hybrid production for rust control should be done with planning based on detailed knowledge of pathogenic potential of parasite populations.

The range of host variation for specific resistance to most of the cereal rust fungi is apparently much beyond our present ability to fully study. Thus, programs must be alined to obtain usable results. Some means need to be developed to separate and use both specific seedling and specific mature plant resistances.

Knowledge of pathogenic specialization in plant disease forecasts should allow more accurate forecasting methods when cultivars having specific resistances are extensively grown. Assay of pathogenic potential in this case essentially should serve as a warning service that certain genes for resistance will no longer be effective in the future. Information concerning pathogenic potential is presently used to a small extent in disease forecasting but improved methods should add precision to the practice.

LITERATURE CITED

- (1) ANONYMOUS.
1959. A PROPOSED MODIFICATION OF THE SYSTEM OF WHEAT LEAF RUST RACE IDENTIFICATION AND NOMENCLATURE. (Committee of North American Leaf Rust Workers). U.S. Dept. Agr. Plant Dis. Rptr. 43: 613-615.
- (2) _____
1961. THE NORTH AMERICAN 1961 SET OF SUPPLEMENTAL DIFFERENTIAL WHEAT VARIETIES FOR LEAF RUST RACE IDENTIFICATION. (Committee of North American Wheat Leaf Rust Workers). U.S. Dept. Agr. Plant Dis. Rptr. 45: 444-446.
- (3) ATHWAL, D. S.
1953. GENE INTERACTION AND INHERITANCE OF RESISTANCE TO STEM RUST OF WHEAT. Indian Jour. of Genet. and Plant Breeding 13: 91-103.
- (4) BAKSHI, J. S., and SCHLEHUBER, A. M.
1959. IDENTIFICATION OF A SUBSTITUTED CHROMOSOME PAIR IN A TRITICUM-AGROPYRON LINE. Okla. Acad. Sci. Proc. 39: 16-21.
- (5) BARTOS, P., DYCK, P. L., and SAMBORSKI, D. J.
1969. ADULT-PLANT LEAF RUST RESISTANCE IN THATCHER AND MARQUIS WHEAT: A GENETIC ANALYSIS OF THE HOST-PARASITE INTERACTION. Canad. Jour. Bot. 47: 267-269.
- (6) BASILE, RITA.
1957. A DIAGNOSTIC KEY FOR THE IDENTIFICATION OF PHYSIOLOGIC RACES OF PUCCINIA RUBIGRO-VERA TRITICI GROUPED ACCORDING TO A UNIFIED NUMERATION SCHEME. U.S. Dept. Agr. Plant Dis. Rptr. 41: 508-511.
- (7) BLACK, W., MASTENBROEK, C., MILLS, W. R., and PETERSON, L. C.
1953. A PROPOSAL FOR AN INTERNATIONAL NOMENCLATURE OF RACES OF PHYTOPHTHORA INFESTANS AND OF GENES CONTROLLING IMMUNITY IN SOLANUM DEMISSUM DERIVATIVES. Euphytica 2: 173-179.
- (8) BORLAUG, N. E.
1958. THE USE OF MULTILINEAL OR COMPOSITE VARIETIES TO CONTROL AIRBORNE EPIDEMIC DISEASES OF SELF-POLLINATED CROPS. 1st Internat. Wheat Genet. Symp. Proc., Univ. of Manitoba, Winnipeg, Canada. pp. 12-27. Public Press, Ltd., Winnipeg.

- (9) BROWDER, L. E.
1963. A CONVENIENT VACUUM SOURCE FOR COLLECTING CEREAL RUST UREDIOSPORES IN THE FIELD. *Robigo* 15: 14.
- (10) _____
1965. AN ATOMIZER FOR INOCULATING PLANTS WITH SPORE-OIL SUSPENSION. U.S. Dept. Agr. Plant Dis. Rptr. 49: 455.
- (11) _____
1966. A RAPID METHOD OF ASSAYING PATHOGENIC POTENTIAL OF POPULATIONS OF PUCINIA GRAMINIS TRITICI. U.S. Dept. Agr. Plant Dis. Rptr. 50: 673-676.
- (12) _____
1968. COLLECTING FUNGUS SPORES. U.S. Dept. Agr. Plant Dis. Rptr. 52: 148.
- (13) CALDWELL, R. M., SCHAFER, J. F., COMPTON, L. E., and PATTERSON, F. L.
1957. A MATURE-PLANT TYPE OF WHEAT LEAF RUST RESISTANCE OF COMPOSITE ORIGIN. *Phytopathology* 47: 691-692.
- (14) CHERRY, EDWARD, and PEET, C. E.
1966. AN EFFICIENT DEVICE FOR THE RAPID COLLECTION OF FUNGAL SPORES FROM INFECTED PLANTS. *Phytopathology* 56: 1102-1103.
- (15) CHESTER, K. S.
1946. THE NATURE AND PREVENTION OF THE CEREAL RUSTS AS EXEMPLIFIED IN THE LEAF RUST OF WHEAT. 269 pp. *Chronica Botanica*, Waltham, Mass.
- (1) DA SILVA, A. R.
1958. THE INTEGRATION OF WHEAT BREEDING AND RUST IDENTIFICATION. 1st Internat. Wheat Genet. Symp. Proc., Winnipeg, Canada. pp. 39-48. Public Press Ltd., Winnipeg.
- (17) DYCK, P. L., and SAMBORSKI, D. J.
1968. GENETICS OF RESISTANCE TO LEAF RUST IN THE COMMON WHEAT VARIETIES WEBSTER, LOROS, BREVIT, CARINA, MALAKOF, AND CENTENARIO. *Canad. Jour. Genet. and Cytology* 10: 7-17.
- (18) _____ SAMBORSKI, D. J., and ANDERSON, R. G.
1966. INHERITANCE OF ADULT-PLANT LEAF RUST RESISTANCE DERIVED FROM THE COMMON WHEAT VARIETIES EXCHANGE AND FRONTANA. *Canad. Jour. Genet. and Cytology* 8: 665-671.
- (19) FLANGAS, A. L., and DICKSON, J. G.
1961. COMPLEMENTARY GENETIC CONTROL OF DIFFERENTIAL COMPATIBILITY IN RUSTS. *Quart. Rev. Biol.* 36: 254-272.
- (20) FLOR, H. H.
1942. INHERITANCE OF PATHOGENICITY IN MELAMPSORA LINI. *Phytopathology* 32: 653-669.
- (21) _____
1959. GENETIC CONTROLS OF HOST PARASITE INTERACTIONS IN RUST DISEASES. In Holton, C. S., and others, ed. *Plant Pathology, Problems and Progress, 1908-1958*. pp. 137-144. Univ. Wisconsin Press, Madison.
- (22) GUTHRIE, E. J.
1963. TWO USEFUL TECHNIQUES FOR RUST WORK. *Robigo* 14: 3.
- (23) HORSFALL, J. G., and DIMOND, A. E.
1959. THE DISEASED PLANT. In *Plant Pathology, an Advanced Treatise*, v. 1, pp. 1-17. Academic Press, New York.

- (24) JOHNSON, L. B., and SCHAFER, J. F.
1966. EFFECT OF (2 CHLOROETHYL) TRIMETHYLAMMONIUM CHLORIDE ON PUCCINIA RECONDITA INFECTION. U.S. Dept. Agr. Plant Dis. Rptr. 50: 108-109.
- (25) JOHNSON, T.
1956. PHYSIOLOGIC RACES OF LEAF RUST OF WHEAT IN CANADA 1931-1955. Canad. Jour. Agr. Sci. 36: 371-379.
- (26) JOHNSTON, C. O.
1956. UNIFIED NUMBERS FOR RACES OF PUCCINIA TRITICINIA. Robigo 1: 2-3.
- (27) _____ and BROWDER, L. E.
1966. SEVENTH REVISION OF THE INTERNATIONAL REGISTER OF PHYSIOLOGIC RACES OF PUCCINIA RECONDITA F. SP. TRITICI. U.S. Dept. Agr. Plant Dis. Rptr. 50: 756-760.
- (28) _____ CALDWELL, R. M., COMPTON, L. E., and BROWDER, L. E.
1968. PHYSIOLOGIC RACES OF PUCCINIA RECONDITA F. SP. TRITICI IN THE UNITED STATES FROM 1926 THROUGH 1960. U.S. Dept. Agr. Tech. Bul. 1393, 18 pp.
- (29) _____ and HEYNE, E. G.
1964. WICHITA WHEAT BACK-CROSS LINES FOR DIFFERENTIAL HOSTS IN IDENTIFYING PHYSIOLOGIC RACES OF PUCCINIA RECONDITA. Phytopathology 54: 385-388.
- (30) _____ and MAINS, E. B.
1932. STUDIES ON PHYSIOLOGIC SPECIALIZATION IN PUCCINIA TRITICINIA. U.S. Dept. Agr. Tech. Bul. 313, 22 pp.
- (31) _____ and MELCHERS, L. E.
1929. GREENHOUSE STUDIES ON THE RELATION OF AGE OF WHEAT PLANTS TO INFECTION BY PUCCINIA TRITICINIA. Jour. Agr. Res. 38: 147-157.
- (32) LEATH, K. T., ROMIG, R. W., and ROWELL, J. B.
1966. A SYSTEM FOR STORING RUST SPORES IN LIQUID NITROGEN. Phytopathology 56: 570.
- (33) LOEGERING, W. Q.
1966. THE RELATIONSHIP BETWEEN HOST AND PATHOGEN IN STEM RUST OF WHEAT. 2d. Internat. Wheat Genet. Symp. Proc., Lund, Sweden, 1963. Hereditas Sup. 2: 167-177.
- (34) _____ HARMON, D. L., and CLARK, W. A.
1961. A LONG TERM EXPERIMENT FOR PRESERVATION OF UREDIOSPORES OF PUCCINIA GRAMMINIS TRITICI IN LIQUID NITROGEN. U.S. Dept. Agr. Plant Dis. Rptr. 45: 384-385.
- (35) _____ HARMON, D. L., and CLARK, W. A.
1966. STORAGE OF UREDIOSPORES OF PUCCINIA GRAMMINIS TRITICI IN LIQUID NITROGEN. U.S. Dept. Agr. Plant Dis. Rptr. 50: 502-506.
- (36) MAINS, E. B., and JACKSON, H. S.
1921. STRAINS OF PUCCINIA TRITICINIA ON WHEAT IN THE UNITED STATES. (Abstract) Phytopathology 11: 40.
- (37) _____ and JACKSON, H. S.
1926. PHYSIOLOGIC SPECIALIZATION IN THE LEAF RUST OF WHEAT; PUCCINIA TRITICINIA ERIKSS. Phytopathology 16: 89-119.
- (38) _____ LEIGHTY, C. L., and JOHNSTON, C. O.
1926. INHERITANCE OF RESISTANCE TO LEAF RUST, PUCCINIA TRITICINIA ERIKSS., IN CROSSES OF COMMON

- WHEAT, TRITICUM VULGARE
VILL. Jour. Agr. Res. 32:
931-972.
- (39) MCINTOSH, R. A., and BAKER,
E. P.
1966. CHROMOSOME LOCATION OF
MATURE PLANT LEAF RUST
RESISTANCE IN CHINESE
SPRING WHEAT. Austral.
Jour. Biol. Sci. 19: 943-
944.
- (40) PERSON, CLAYTON.
1959. GENE-FOR-GENE RELATION-
SHIPS IN HOST: PARASITE
SYSTEMS. Canad. Jour.
Bot. 37: 1101-1130.
- (41) ROELFS, A. P., and JOHNSTON,
C. O.
1966. COMPARISON OF METHODS
OF ANALYSIS OF FIELD COL-
LECTIONS OF PUCCINIA RE-
CONDITA F. SP. TRITICI.
Phytopathology 56: 1143-
1148.
- (42) ROWELL, J. B.
1957. OIL INOCULATION OF
WHEAT WITH SPORES OF
PUCCINIA GRAMINIS TRITICI.
Phytopathology 47: 689-
690.
- (43) _____ and LOEGERING, W. Q.
1963. GENETIC MODEL FOR PHY-
SIOLOGIC STUDIES OF MECH-
ANISMS GOVERNING DEVEL-
OPMENT OF INFECTION
TYPE IN WHEAT STEM
RUST. Phytopathology 53:
932-937.
- (44) _____ and OLIEN, C. R.
1957. CONTROLLED INOCULATION
OF WHEAT SEEDLINGS WITH
UREDIOPORES OF PUCCINIA
GRAMINIS VAR. TRITICI.
Phytopathology 47: 650-
655.
- (45) SAMBORSKI, D. J.
1963. A MUTATION IN PUCCINIA
RECONDITA ROB. EX. DESM.
F. SP. TRITICI TO VIRULENCE
ON TRANSFER, CHINESE
SPRING X AEGILOPS UM-
BELLULATA ZHUK. Canad.
Jour. Bot. 41: 475-479.
- (46) _____
1965. LEAF RUST OF WHEAT IN
CANADA IN 1964. Canad.
Plant Dis. Survey 46: 33-
35.
- (47) _____ and DYCK, P. L.
1968. INHERITANCE OF VIRU-
LENCE IN WHEAT LEAF
RUST ON THE STANDARD
DIFFERENTIAL WHEAT VARI-
ETIES. Canad. Jour. Genet.
and Cytology 10: 24-32.
- (48) SCHAFFER, J. F., CALDWELL, R. M.,
PATTERSON, F. L., and COMP-
TON, L. E.
1968. WHEAT LEAF RUST RESIS-
TANCE COMBINATIONS. Phy-
topathology 58: 569-573.
- (49) SHARMA, D., and KNOTT, D. R.
1966. THE TRANSFER OF LEAF-
RUST RESISTANCE FROM
AGROPYRON TO TRITICUM BY
IRRADIATION. Canad. Jour.
Genet. and Cytology 8:
137-143.
- (50) SHARP, E. L., and SMITH, F. G.
1952. PRESERVATION OF PUCCINIA
UREDIOPORES BY LYOPHILIZ-
ATION. Phytopathology
42: 263-264.
- (51) SIMONS, M. D.
1955. AN EXAMINATION OF THE
PRESENT STATUS AND PRO-
POSED MODIFICATIONS OF
THE ANNUAL CROWN RUST
RACE SURVEY IN THE
UNITED STATES. U.S. Dept.
Agr. Plant Dis. Rptr. 39:
956-959.
- (52) SOLIMAN, A. S., HEYNE, E. G.,
and JOHNSTON, C. O.
1963. RESISTANCE TO LEAF RUST
IN WHEAT DERIVED FROM
CHINESE AEGILOPS UMBEL-
LULATA TRANSLOCATION
LINES. Crop Sci. 3: 254-
256.
- (53) _____ HEYNE, E. G., and JOHN-
STON, C. O.

1964. GENETIC ANALYSIS OF LEAF RUST RESISTANCE IN EIGHT DIFFERENTIAL VARIETIES OF WHEAT. *Crop Sci.* 4: 246-248.
- (54) STARKMAN, E. C.
1964. WILL THE FIGHT AGAINST WHEAT RUST EVER END? *Ztschr. f. Pflanzenkrank. u. Pflanzenschutz* 71: 67-73.
- (55) _____ and LEVINE, M. N.
1922. THE DETERMINATION OF BIOLOGIC FORMS OF PUC-CINIA GRAMINIS ON TRITICUM SPECIES. *Minn. Agr. Expt. Sta. Tech. Bul.* 8, 10 pp.
- (56) _____ and LOEGERING, W. Q.
1941. PHYSIOLOGIC RACES OF PUC-CINIA GRAMMIS IN THE UNITED STATES IN 1939. U.S. Dept. Agr. Bur. Ent. and Plant Quar. Bul. E-522. [Mimeographed.]
- (57) _____ and PIEMBEISAL, F. J.
1917. BIOLOGIC FORMS OF PUC-CINIA GRAMINIS ON CEREALS AND GRASSES. *Jour. Agr. Res.* 10: 429-495.
- (58) _____ and RODENHISER, H. A.
1958. RACE 15B OF WHEAT STEM RUST—WHAT IT IS AND WHAT IT MEANS. *Adv. in Agron.* 10: 143-165.
- (59) _____ STEWART, D. M., and LOEGERING, W. Q.
1962. IDENTIFICATION OF PHYSIOLOGIC RACES OF PUC-CINIA GRAMINIS VAR. TRITICI. U.S. Dept. Agr., Agr. Res. Serv. Pub. E-617 (Revised 1962.)
- (60) TERVET, I. W., RAWSON, A. J., CHERRY, EDWARD, and SAXON, R. B.
1951. A METHOD OF COLLECTING MICROSCOPIC PARTICLES. *Phytopathology* 41: 282-285.
- (61) WATSON, I. A., and LUIG, N. H.
1961. LEAF RUST ON WHEAT IN AUSTRALIA: A SYSTEMATIC SCHEME FOR THE CLASSIFICATION OF STRAINS. *Linn. Soc. New South Wales Proc.* 86: 241-250.
- (62) WILLIAMS, N. D., GOUGH, F. J., and RONDON, M. R.
1966. INTERACTION OF PATHOGENICITY GENES IN PUC-CINIA GRAMINIS F. SP. TRITICI AND REACTION GENES IN TRITICUM AESTIVUM SSP. VULGARE 'MARQUIS' AND 'RELIANCE.' *Crop Sci.* 6: 245-248.
- (63) WILLIAMS, W.
1964. GENETICAL PRINCIPLES AND PLANT BREEDING. 504 pp. Blackwell, Oxford, and Davis, Philadelphia.
- (64) YOUNG, H. C., JR., and BROWDER, L. E.
1965. THE NORTH AMERICAN 1965 SET OF SUPPLEMENTAL DIFFERENTIAL WHEAT VARIETIES FOR IDENTIFICATION OF RACES OF PUC-CINIA RECONDITA TRITICI. U.S. Dept. Agr. Plant Dis. Rptr. 49: 308-311.
- (65) ZADOKS, J. C.
1963. THE USE OF RACE NURSERIES IN CEREAL RESISTANCE BREEDING. First Internat. Barley Genet. Symp. Proc., Wageningen. pp. 242-249.
- (66) _____
1966. PROBLEMS IN RACE IDENTIFICATION OF WHEAT RUSTS. 5th Yugoslav Symp. on Res. in Wheat Proc. pp. 299-307.

END