



AgEcon SEARCH
RESEARCH IN AGRICULTURAL & APPLIED ECONOMICS

The World's Largest Open Access Agricultural & Applied Economics Digital Library

This document is discoverable and free to researchers across the globe due to the work of AgEcon Search.

Help ensure our sustainability.

Give to AgEcon Search

AgEcon Search
<http://ageconsearch.umn.edu>
aesearch@umn.edu

*Papers downloaded from **AgEcon Search** may be used for non-commercial purposes and personal study only. No other use, including posting to another Internet site, is permitted without permission from the copyright owner (not AgEcon Search), or as allowed under the provisions of Fair Use, U.S. Copyright Act, Title 17 U.S.C.*

1B-1349 (1967) USDA TECHNICAL BULLETINS UPDATA
LANDSCAPE EVOLUTION AND SOIL FORMATION IN SOUTHWESTERN IOWA
RUHE, R. W. DANIELS, R. B. GADY, J. G. M. 1 OF 4

START

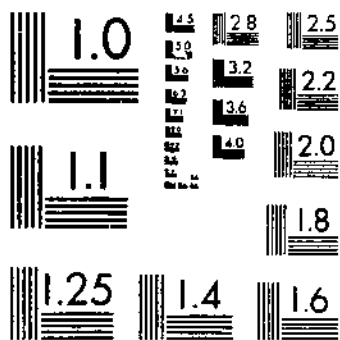

MICROCOPY RESOLUTION TEST CHART
NATIONAL BUREAU OF STANDARDS-1963-A

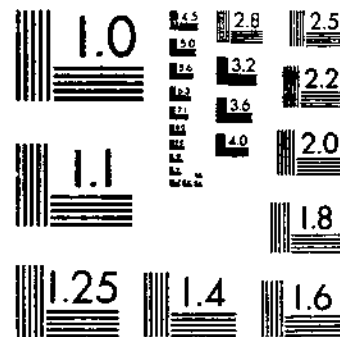

MICROCOPY RESOLUTION TEST CHART
NATIONAL BUREAU OF STANDARDS-1963-A

LANDSCAPE EVOLUTION | IN
AND SOIL FORMATION | SOUTHWESTERN
IOWA

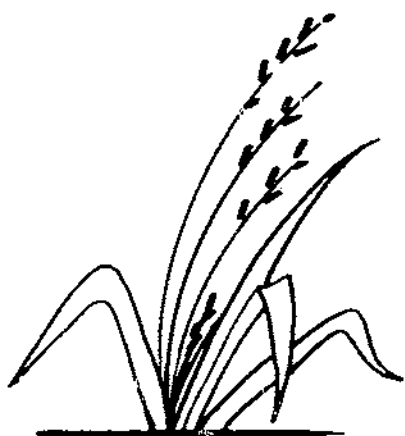

Technical Bulletin 1349

Issued — June 1967

Robert V. Ruhe, *research geologist*, and
Raymond B. Daniels and John G. Cady, *soil scientists*

Soil Conservation Service
U.S. DEPARTMENT OF AGRICULTURE
in cooperation with the
Iowa Agriculture and Home Economics Experiment Station
Iowa Geological Survey

Foreword

This bulletin tells how natural erosion has helped shape the landscapes of southwestern Iowa and affected the kinds of soil and their distribution. In soil mapping the scientist looks for changes in the soil wherever there is a change in one of the soil-forming factors. The extent to which he can identify and interpret correctly changes in the age of the land surface influences the efficiency of his work and the accuracy of his maps.

Only recently have attempts been made to study the precise effects of natural erosion on soil genesis. These relationships are important to soil classification, to the drawing of soil boundaries in the field, and to predictions of how soils will behave under use. The understanding of them is critical to the main purposes of our soil surveys. Studies of loess thickness in Illinois show that on many sloping ridges there has been no significant erosion since the loess was deposited. On other slopes comparable in gradient many feet of loess were removed by erosion prior to settlement. Obviously, erosion has not everywhere been active to the same extent.

Studies of the soils in southern Iowa showed that soils on what appeared to be comparable slope and parent material differed widely in their properties. Some appeared to be very weakly developed and were comparable to those on the most recent glacial tills. Others were strongly developed but no predictions could be made about the precise locations where a given kind of soil might be found. Apparently erosion had been active at different times, but no clues were known for distinguishing between the younger and the older surfaces.

This bulletin shows that there have been many periods in the past when erosion was active and that the land surfaces on different parts of the side of a single hill may have been formed at different times. Evidences of repeated erosion cycles are stepped slopes formed by the successive cycles of erosion. On such slopes the youngest surfaces lie below the lowest step; the surfaces increase in age upward from step to step. Therefore, the soil scientist should look for the changes in soils that are associated with time at any of the steps on the slope. The bulletin tells how the soils in southwestern Iowa differ on land surfaces of different age.

The text will require study. The evidences are technical, and most soil scientists will need to develop a new vocabulary to understand them. Yet if one is interested in how the pattern of soils is related to cyclic erosion, this bulletin is well worth the time and study necessary to understand it. The evidences of cyclic erosion explained here may be seen over and over in most humid parts of the world. They are not unique to Iowa. The relations between soil and erosion cycles are not everywhere the same. They can only be worked out area by area but the methodology can be developed from the pattern given here.

Guy D. Smith
Director, Soil Survey Investigations

Preface

Landscape Evolution and Soil Formation in Southwestern Iowa is a report of a project of Soil Survey Investigations, Soil Conservation Service, undertaken in 1953. The major objective of the research was to evaluate the influence of geomorphologic processes and history in the genesis, geography, and classification of soils in selected areas in southwestern Iowa. The work was done from 1953 through 1956; the original manuscript was written in 1957. Since then changes have been made in the classification of the Wisconsin glacial stage in Iowa and adjacent States. The material presented in this bulletin should be read within the context of these changes published in:

- RUHE, R. V., RUBIN, M., and SCHOLTES, W. H. 1957. LATE PLEISTOCENE RADIO-CARBON CHRONOLOGY IN IOWA. *Amer. J. Sci.* 255: 671-680.
- RUHE, R. V. and SCHOLTES, W. H. 1959. IMPORTANT ELEMENTS IN THE CLASSIFICATION OF THE WISCONSIN GLACIAL STAGE—A DISCUSSION. *J. Geo.* 67: 585-593.
- WRIGHT, H. W. and RUHE, R. V. *Glaciation of Minnesota and Iowa*, p. 29-41, and RUHE, R. V. *Quaternary paleopedology*, p. 755-764. In WRIGHT, HERBERT E. JR., and D. G. FREY, eds. 1965. THE QUATERNARY OF THE UNITED STATES; A REVIEW VOLUME FOR THE 7TH CONGRESS OF THE INTERNATIONAL ASSOCIATION FOR QUATERNARY RESEARCH. Princeton Univ. Press.
- RUHE, R. V. 1965. IDENTIFICATION OF PALEOSOLS IN LOESS DEPOSITS IN THE UNITED STATES. *Nabr. Acad. Sci. Proc.*, INQUA Symposium on loess and related eolian deposits of the world.

The report is presented in four parts. Chapter 1 discusses the relationships of Pleistocene geology, geomorphology, and soils along a traverse between Bentley and Adair in southwestern Iowa. This chapter gives the essential geologic and geomorphologic background for the succeeding studies reported in chapters 2, 3, and 4.

Chapter 2 discusses the areal relationships of the Pleistocene geology and geomorphology in parts of the Greenfield quadrangle, Adair County, Iowa. The eastern end of the regional traverse described in chapter 1 is in the northwest corner of the Greenfield quadrangle. Thus, it was possible to integrate the regional-traverse study with a detailed areal study. The areal study is geologic and geomorphologic background for the detailed soils study.

In chapter 3 soils of parts of the Greenfield quadrangle are described and discussed in detail and are related to the geology and geomorphology of the area.

In chapter 4 the methodology of the soil-geomorphologic studies of the Greenfield quadrangle is applied to a small watershed in the thick loess area in the vicinity of cut 39 along the regional traverse between Bentley and Adair.

The report is an evaluation of landscape evolution and soil formation in a humid temperate region.

A. J. Cline and F. J. Carlisle, soil correlators, Soil Conservation Service, aided in the soils studies. The interest in the research of H. G. Hershey, Director, Iowa Geological Survey, and F. F. Riecken, professor of soils, Iowa State University, is appreciated. Many of the laboratory analyses reported here were made by personnel of the Soil Survey Laboratory.

Contents

	Page
CHAPTER 1 The relation of Pleistocene geology and soils between Bentley and Adair in Southwestern Iowa, by Robert V. Ruhe and John G. Cady.....	1
Introduction.....	1
Pleistocene stratigraphy.....	2
Nebraskan till.....	6
Aftonian clay.....	11
Kansan till.....	14
Yarmouth clay.....	20
Loveland loess.....	26
Wisconsin loess.....	32
Geomorphology.....	44
Yarmouth-Sangamon surface.....	44
Sangamon surface.....	47
Late Sangamon surface.....	58
Wisconsin Surface-complex.....	71
Early Wisconsin surface of dissection.....	72
Early Wisconsin (Iowan) terrace.....	72
Late Wisconsin surface of dissection.....	72
Recent gully cut-and-fill surface.....	76
Relationship of Pleistocene stratigraphy and geomorphology to soils.	77
Yarmouth-Sangamon surface, Late Sangamon pediment, and Wisconsin dissection.....	77
Sangamon surface, Late Sangamon pediment, and Wisconsin dissection.....	82
Wisconsin surfaces.....	85
 CHAPTER 2 Geomorphology of parts of the Greenfield quadrangle, Adair County, Iowa, by Robert V. Ruhe.....	 93
Introduction.....	93
Pleistocene deposits.....	94
Nebraskan till.....	84
Kansan till.....	96
Wisconsin loess.....	97
Geomorphic surfaces.....	101
Landscape.....	101
Yarmouth-Sangamon surface.....	104
Late Sangamon surface.....	113
Early Wisconsin surfaces.....	136
Late Wisconsin-Recent complex.....	143
Relation of Pleistocene deposits, geomorphic surfaces, and soils.....	156
Resurrection of Paleosolic surfaces.....	157
Tazewell upland and soils.....	158
Late Wisconsin-Recent complex and soils.....	160

	Page
CHAPTER 3 Soils of the South Turkey Creek area, Greenfield quadrangle, Adair County, Iowa, by Raymond B. Daniels and John G. Cady	163
Introduction	163
Soils	163
Laboratory procedures	163
Exposed paleosols	165
Paleo-geomorphic surfaces and soil geography	168
Soils of the Tazewell uplands	169
Soils of the late Wisconsin-Recent complex	174
Soils on valley slopes in Kansan till	179
Soils in valley-side alluvium	189
Discussion	195
Factors influencing soil formation	201
History of the soils	202
CHAPTER 4 Soil landscapes in the thick loess of central Pottawattamie County, Iowa, by Raymond B. Daniels	205
Introduction	205
Pleistocene and recent deposits	206
Geomorphic surfaces	209
Soils	212
Morphology	212
Physical and chemical properties	217
Summary and conclusions	224
Literature cited	225
Appendix	233

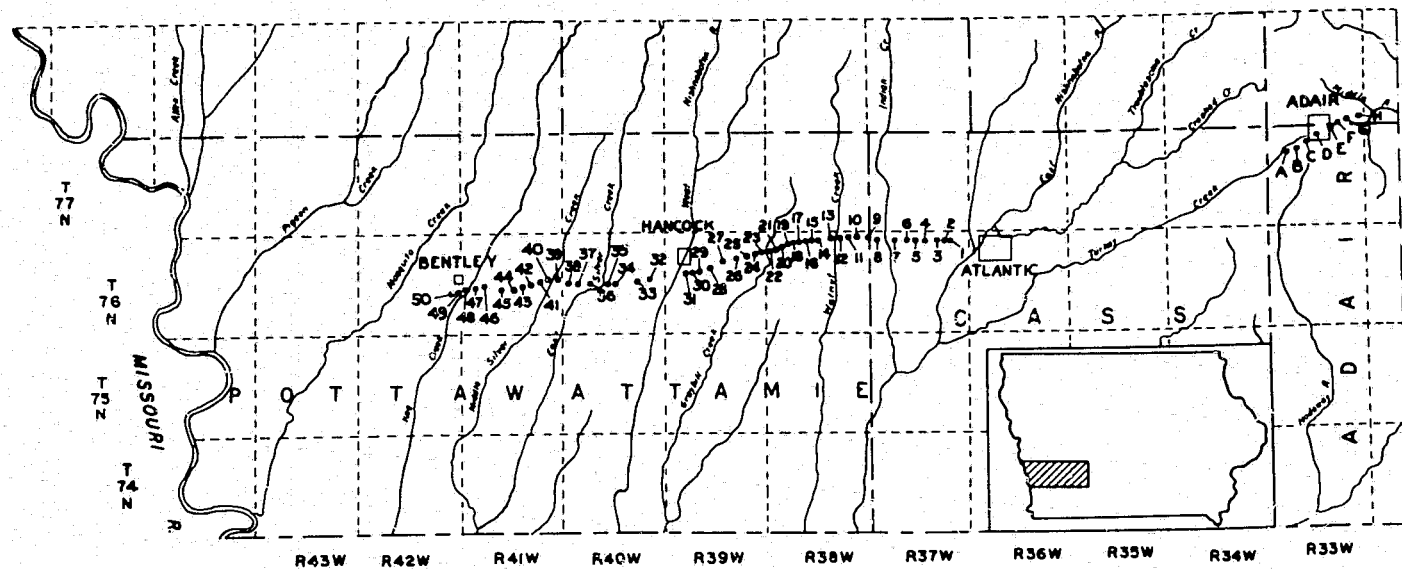

FIGURE 1.—Location of traverse in Pottawattamie, Cass, and Adair Counties, southwestern Iowa. Cuts and sections are numbered 1 to 50 and lettered A to H. (See pl. I).

Chapter I

The Relation of Pleistocene Geology and Soils Between Bentley and Adair in Southwestern Iowa

by Robert V. Ruhe, *research geologist*, and John G. Cady, *soil scientist*,
Soil Conservation Service

Introduction

During 1953-54, a detailed field study of the Pleistocene geology and geomorphology was completed along a traverse from Bentley, Pottawattamie County, to near Adair, Adair County, Iowa (fig. 1). The traverse is composed of two segments: (1) From Bentley to Atlantic, Iowa, and (2) from Turkey Creek west of Adair, Iowa, to Middle River to the east. The two segments are separated by a gap of about 21 miles.

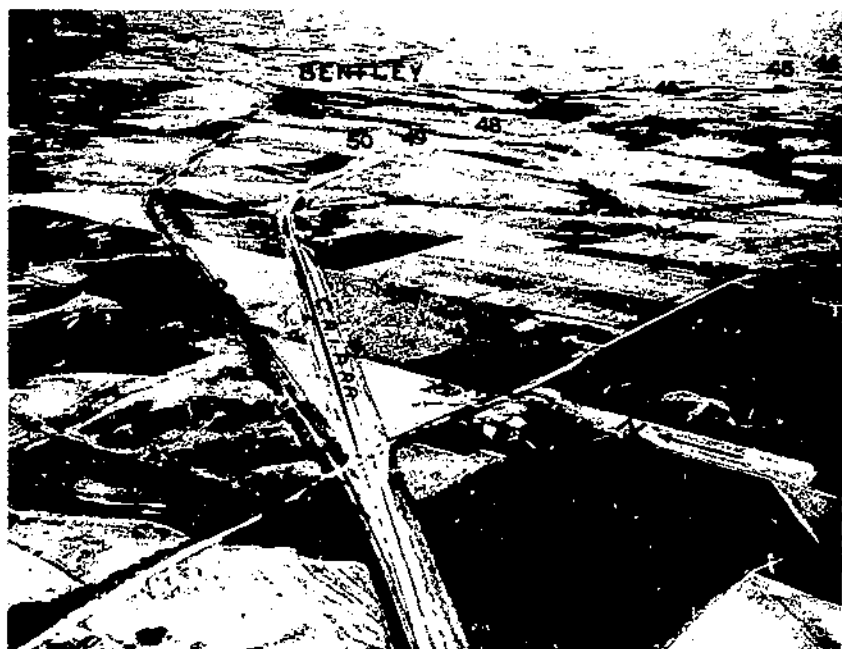

FIGURE 2.—Undulating to rolling, loess-mantled topography along western end of traverse near Bentley, Iowa. Cuts 50 to 44 are located. (Airphoto by Pilot-Photographer Don Ultang, Des Moines Tribune, Sept. 3, 1953.)

The location of the traverse was determined by the construction of the relocations of the Chicago, Rock Island, and Pacific Railroad in these areas. Fifty-eight major cuts, some 60 to 70 feet deep and $\frac{1}{2}$ to $\frac{3}{4}$ mile long, were made along the traverse between October 1951 and early summer 1954. As a result, excellent exposures of Pleistocene deposits, as well as soils, were available for study (46).¹

The traverse transects the loess-mantled Kansan drift plain in southwestern Iowa, which Kay and Graham (26, p. 76, 160) called loess-mantled erosional topography. The terrain is generally undulating to rolling and has slopes ranging from 3 to 15 percent (fig. 2).

Pleistocene Stratigraphy

At the time this study began, the Pleistocene section in southwestern Iowa was recognized as shown in table 1. Thus, it was composed mainly of two drifts overlain by two major loess sheets. From the base upward was Nebraskan drift, Kansan drift, Loveland loess, and Wisconsin loess. Buried soils, weathered zones, erosion surfaces, or interbedded sediments separated the members of the sequence. The uppermost loess contained interbedded buried soils.

TABLE 1.—General Pleistocene section in southwestern Iowa

Glacial stage	Interglacial stage	Evidence	Authority
Wisconsin	Mankato	Loess	Ruhe (46)
	Cary		
	Tazewell-Cary	Soil	
	Tazewell	Loess	
	Iowan		
	Farmdale-Iowan	Soil	
Farmdale	Loess	Mickelson (38)	
	Sangamon	Weathered zones, soils, peat, erosion.	Kay and Graham (26, 45-55). Kay and Graham (26, 63-75). Mickelson (38)
Illinoian		Loveland loess	Leighton and Willman (33, 601-602).
Kansan	Yarmouth	Soils, erosion, sediments.	Kay and Apfel (25, 257-281).
		Drift	Kay and Apfel (25, 212-256).
Nebraskan	Aftonian	Soils, peat, weathered zones, erosion.	Kay and Apfel (25, 183-199).
		Drift	Kay and Apfel (25, 141-145).

¹ Italicized numbers in parentheses refer to Literature Cited, p. 225.

MINERALOGY

Mineralogical composition of selected examples of the different deposits exposed in the railroad cuts was studied by optical, X-ray, and differential thermal procedures.² Most of the samples came from the Sangamon soil profiles in the Loveland loess, but samples from Farmdale loess, basal Wisconsin loess, Kansan till, Nebraskan till, the Yarmouth and Aftonian clays, and modern soils in Wisconsin loess also were included. Table 2 lists the locations and stratigraphic positions of the samples from the railroad cuts. In addition to these samples a Marshall and a Dow soil profile near the railroad cuts and several miscellaneous samples from farther east and west were studied.

Samples were dispersed by standard procedures and separated into sand, silt, and clay fractions by sieving and decantation. Sand and coarse-silt fractions were examined with the petrographic microscope, and estimates were made of general composition. Heavy minerals in the 50- to 100- and 20- to 50-micron fractions were separated and the composition of the heavy separates determined by counting several hundred grains. The 2- to 20-micron silt was examined with the petrographic microscope and also by X-ray diffraction on nonoriented powder mounts.

The clay fraction was analyzed as oriented aggregates on glass slides with magnesium saturation and glycerol solvation and with potassium saturation and heating by stages to 500° C.

Selected representative samples of different materials were studied by differential thermal analysis.

In general, all the tills, clays, and loesses contain the same mineral suite with different proportions of minerals due to variations in source during deposition and in weathering either before or after deposition.

Quartz, chert, and assorted feldspar are the major components. Feldspar content is fairly high in most of the sand fractions, ranging from 15 to 30 percent, but it diminishes with decreasing particle size to a few percent in the finer silt. Muscovite and biotite are always present but vary greatly according to degree of weathering. Volcanic glass is present in traces in most of the loess and clay samples but is rare or absent in the tills.

Heavy-mineral weight percentage ranges roughly from 1.0 to 2.0 percent. Among the heavy minerals the following minerals or groups of minerals make up appreciable percentages:

Hornblende (and other amphiboles and pyroxenes). The abundant member of this group is the typical variety of green, slightly pleochroic hornblende; basaltic hornblende is the second most abundant in the group, generally about one-fifth to one-third as common as the green variety. Also present are tremolite, actinolite, augite, diopside, enstatite, and hypersthene. Because the group is dominated by hornblende and because it is believed that all are affected similarly by weathering, they are included with hornblende in reporting the results of counts.

² William F. Holton prepared separates and thin sections and assisted in mineralogical analyses.

TABLE 2.—Location of railroad-cut samples for mineralogic study

Cut 50	Cut 45	Cut 39	Cut 33	Cut 31	Cut 26	Cut 25	Cut 3
Leached basal Wisconsin loess (34). ¹ Farmdale A _b horizon (35). Farmdale A _b horizon (36).				Leached basal Wisconsin loess (19). Farmdale A _b horizon (18). Farmdale A _b horizon (17).	Farmdale A horizon (12).		Farmdale C horizon (1).
Farmdale-Sangamon transition (37). Sangamon B horizon (38).	Sangamon B horizon (54).	Sangamon B ₁ horizon (28). Sangamon B ₂ horizon (29).	Sangamon B ₁ horizon (27). Sangamon B ₂ horizon (26).	Farmdale-Late Sangamon transition (16). Late Sangamon B ₁ horizon (15). Late Sangamon B ₂ horizon (14).	Farmdale-Sangamon transition (11). Sangamon A horizon (10). Sangamon B horizon (9).	Sangamon B horizon (56). Sangamon C horizon (53).	
Sangamon C horizon (39). Intra-Illinoian A horizon (40).	Sangamon C horizon (55).	Sangamon C horizon (30). Intra-Illinoian A horizon (31). Intra-Illinoian B horizon (32).	Intra-Illinoian A horizon (25). Intra-Illinoian B horizon (24).				
Intra-Illinoian C horizon (41).		Intra-Illinoian C horizon (33).	Intra-Illinoian C horizon (23). Yarmouth clay (22).		Yarmouth A horizon (8). Yarmouth clay (7).		Yarmouth clay (2). Yarmouth clay (3).

			C horizon- Kansan till (21).		Silt between clay and till (6).
			Aftonian clay (13).		B horizon in Kansan till (4).
			Nebraskan till (20).		C horizon in Kansan till (5).

¹Sample No.

Epidote. Included with epidote are zoisite and clinozoisite. Most of the epidote group, especially in the smaller sizes, is colorless or pale green, slightly altered, and much of it more nearly resembles published descriptions of zoisite and clinozoisite than true epidote. It is a very common mineral in all the samples and presumably is moderately resistant to weathering.

Garnet. Garnet is common and widely distributed. Most of it is colorless or very pale pink but in larger sizes some is deep pink and there are a few brown grains. Though generally considered a stable mineral, the variations in amount of garnet suggest that it weathers at least as readily as epidote.

Titanium minerals. Sphene, rutile, and anatase are the common members of this group. In small sizes the sphene is colorless and sometimes is difficult to distinguish from broken zircon fragments. Several varieties of rutile and anatase are present. In the silt fractions brownish and yellowish granular aggregates with high birefringence are the abundant titanium mineral. These may be either rutile or anatase and are possibly authigenic.

Zircon. Several varieties are present, including clear, sharp tetragonal prisms; rounded, clear ovoid grains; zoned, flattened brown crystals; and broken fragments of clear crystals. Zircon is one of the most resistant minerals.

Tourmaline. Though tourmaline is very resistant to chemical weathering, there are only small amounts in these deposits. The pale pink-to-green variety is the most common, but a few pink-dark brown and some practically colorless grains are present.

Other minerals totaling only a few percent of the heavy fraction include kyanite, sillimanite, staurolite, andalusite, corundum, spinel, and apatite. Kyanite and staurolite are more abundant in tills than in loesses and clays. Apatite is variable since it is easily weathered but is common in unweathered loesses and tills.

Opaque minerals. Generally 30 to 50 percent of each heavy separate is composed of opaque grains and almost opaque aggregates. These were not included in the percentages reported because of the difficulty of identifying them and readily distinguishing primary grains such as magnetite and ilmenite from secondary aggregates, cemented by iron or manganese oxides. Manganese oxide concretions are common in the sand and silt fractions as shown by tests with hydrogen peroxide.

Nebraskan Till

Two older glacial tills, Nebraskan and Kansan, have been recognized in southwestern Iowa (25, pp. 141-146). The two tills have been separated generally by a "gumbotil"³ in the uppermost part of the subjacent Nebraskan till, or by leached gravels or peat between the two tills.

In seven of the cuts (pl. I: 9, 28, 29, 30, 31, G, H) along the traverse, two tills are exposed. The lower in these sections is believed to be the Nebraskan and the upper the Kansan. The two

³ Gumbotil, although considered by Kay (25, p. 182) to be something other than a soil, has been recognized recently (56, 60) as a buried soil and generally a Planosolic or Humic-Gley soil.

tills generally do not differ distinctly from each other in their least weathered zones, the oxidized and unleached till. They are a yellowish brown (10YR 5/6-5/8),¹ coarse angular blocky loam to clay loam. For example, the textures and mineralogical compositions (sand fractions) of oxidized and unleached Nebraskan and Kansan tills of cut 31 do not differ greatly (table 3).

TABLE 3.—*Textural and mineralogical comparison of Nebraskan and Kansan tills, cut 31*

Texture and mineralogy	Nebraskan	Kansan
Texture: ¹	<i>Percent</i>	<i>Percent</i>
Sand and gravel (>62 μ).....	27.1	29.4
Very coarse silt (62-31 μ).....	11.8	13.9
Coarse silt (31-16 μ).....	12.7	14.4
Medium silt (16-8 μ).....	6.7	5.4
Fine silt (8-4 μ).....	5.4	6.4
Very fine silt (4-2 μ).....	6.3	4.1
Clay (<2 μ).....	30.0	26.4
Mineralogy: ²		
Quartz.....	80.0	80.0
Limestone-dolomite.....	8.2	6.0
Granite.....	5.1	6.0
Basalt.....	1.1	2.0
Quartzite.....	1.1	1.5
Chert.....	2.5	2.5
Sandstone.....	2.0	2.0

¹ Geologic data concerning particle-size distributions of sediments are reported in terms of a modified Wentworth size classification. Geologists generally consider the upper limit of clay size to be approximately 4 μ . To conform to the soil scientist's upper limit of clay at 2 μ , the size fraction 4-2 μ is classed very fine silt instead of clay as required by the Wentworth size classification. Geologists consider the upper limit of silt size to be $\frac{1}{16}$ mm. (62 μ). The soil scientist's upper limit is 50 μ . To utilize particle-size distributions statistically, a scale of sizes that is based on strict geometric intervals is best. The modified Wentworth scale is so based. The soil scientist's scale is not. Data in this report are presented in both systems.

² ¹/₂ sand and gravel fractions.

Mineralogical composition of the very fine sand, silt, and clay of a sample of this till from cut 31 showed that the sand contains about 25 percent feldspar and that mica is common. The feldspar and mica content decrease with decreasing particle size. High hornblende content of the nonopaque heavy mineral separates from the fine sand and coarse silt (table 4) indicates that the material is relatively fresh and unweathered.

The clay fraction is composed mostly of montmorillonite, with lesser amounts of illite and kaolin. Kaolin content is slightly higher than in the loesses.

In cut 9 (fig. 3) the two tills differ lithologically. The upper Kansan till is bouldery, whereas the lower Nebraskan till contains few boulders.

The Nebraskan till is separated from the overlying Kansan till on the bases of: (1) a buried soil in the uppermost part of the

¹ Munsell soil colors.

CUT 29: W 1/2 sec. 16, T76N, R39W, POTTAWATTAMIE CO. (NORTH FACE)

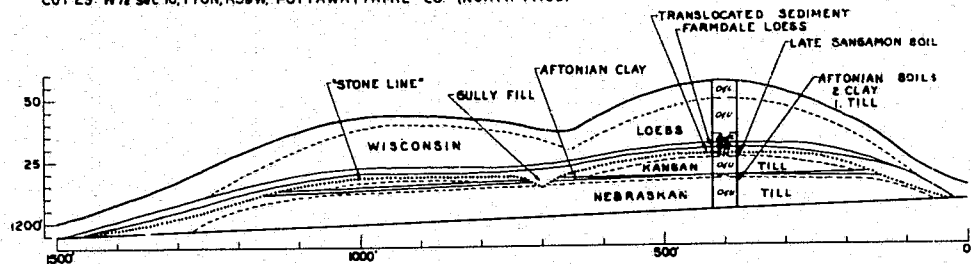

CUT 30: EC sec. 17, T76N, R39W, POTTAWATTAMIE CO. (NORTH FACE)

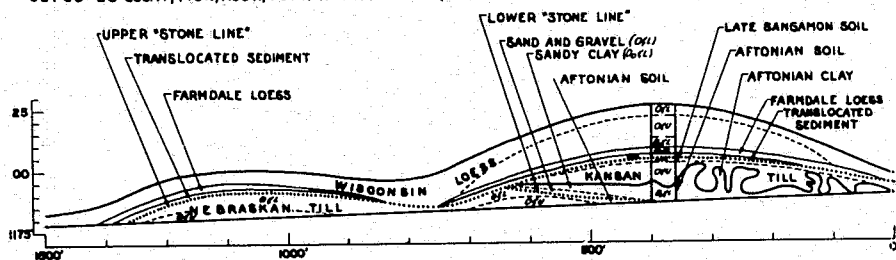

CUT 31: E 1/2 sec. 17, T76N, R39W, POTTAWATTAMIE CO.

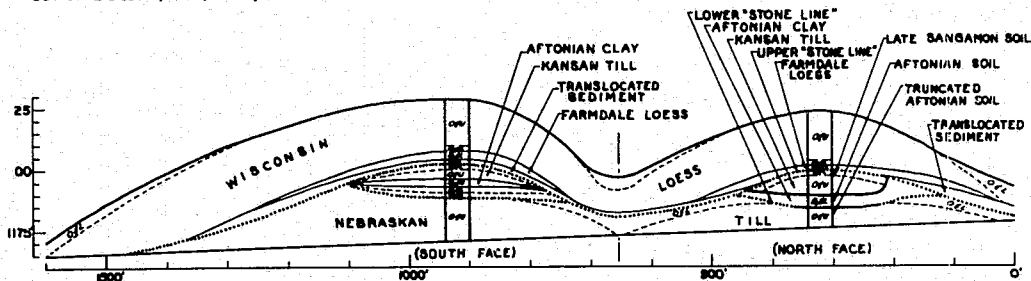

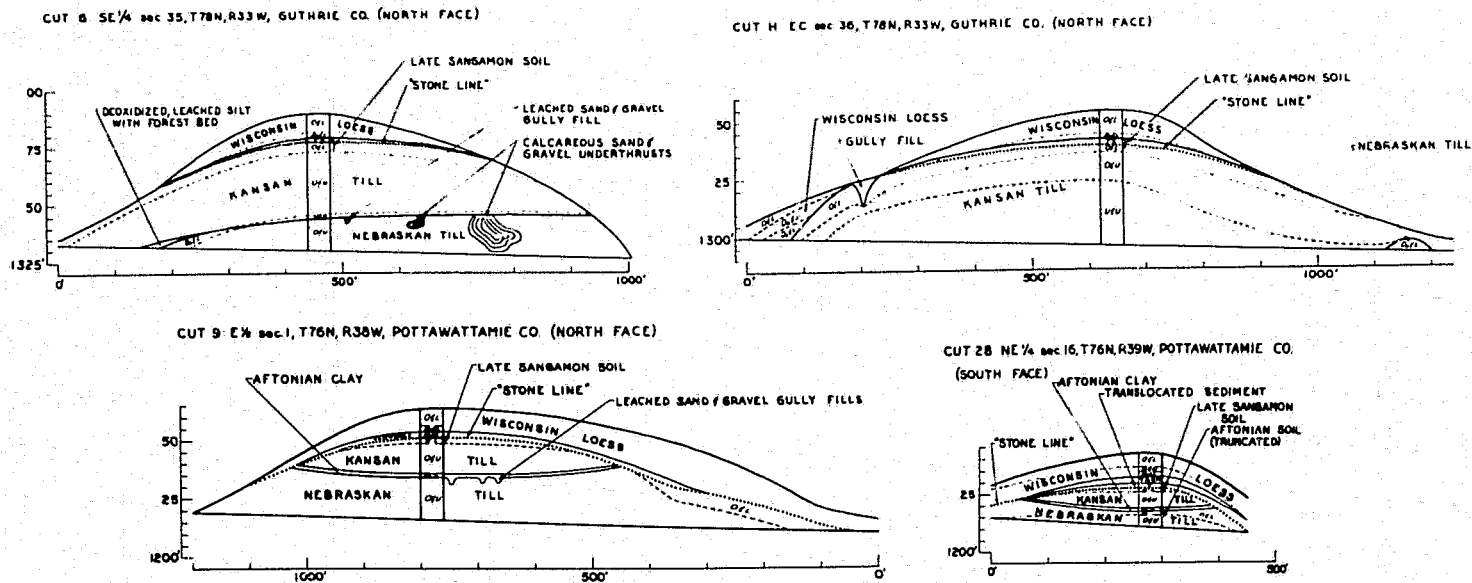

FIGURE 3.—Stratigraphic relationships of the Nebraskan and Kansan tills and other Pleistocene deposits in cuts along traverse. Symbols: O&L: oxidized and leached; Do&L: deoxidized and leached; O&U: oxidized and unleached; U&U: unoxidized and unleached.

TABLE 4.—Proportions of nonopaque heavy minerals, sample 20, cut 31

Mineral	Size-fraction	
	50-100 μ	20-50 μ
.....	Percent	Percent
Fluorite.....	25	27
Tourmaline.....	3	4
Zircon.....	5	17
Garnet.....	10	12
Hornblende.....	50	24
Titanium minerals.....	5	12
Miscellaneous.....	5	4

Nebraskan till, (2) an interbedded sediment that may be a lacustrine clay though leached of carbonate, and (3) an erosion surface marked by a stone line at the top of the Nebraskan till.

For example, between stations 150 and 250, cut G (fig. 3) yellowish brown calcareous Kansan till overlies a Humic-Gley soil profile in Nebraskan till. In the upper 18 inches the buried soil is a dark gray (10YR 4/1), fine subangular blocky, gritty, plastic, leached clay loam. Wood fragments² up to 9 inches in diameter and 24 inches long are imbedded in this zone. From a depth of 18 to 33 inches a gray (10YR 5/1), leached, gritty, plastic, silty clay extends to the base of the cut. This zone also contains wood fragments. In a boring it graded downward into leached, yellowish brown till. At a depth of 95 to 100 inches below the top of the buried Humic-Gley profile the yellowish brown till is calcareous. A contact marked by the top of the buried soil can be traced eastward through the cut, stations 300 to 950, and is distinct even though the upper and lower tills are calcareous. At stations 500, 650, and 800, bedding planes of sand and gravel that extend downward into the lower till are beveled by the base of the upper till. The gravel lens at station 500 is leached of carbonate although overlain by calcareous Kansan till and underlain by calcareous Nebraskan till.

At the eastern end of cut H (fig. 3) the upper part of the Nebraskan till is leached of carbonate and is overlain by calcareous Kansan till.

In both of these sections (G and H) the tills are separated by buried soils or by weathering zones formed during the Aftonian interglacial interval (25, pp. 182-211). In the eastern part of cut G the Kansan glacier ice probably overrode and truncated a topographic high on the Nebraskan till surface so that the Aftonian soil was stripped. Later deposition of till by the Kansan ice brought that younger, unweathered till in contact with the older, unweathered Nebraskan till. At the western end of the cut, the buried Humic-Gley soil occupied a depression on the Aftonian surface on Nebraskan till. The Kansan glacier ice overrode the

² D. W. Bensend, Department of Forestry, Iowa State University identified the wood as spruce (*Picea* sp.).

depression without removing the soil. Calcareous till deposited by the younger glacier ice buried and preserved the Humic-Gley profile.

In cuts 9, 28, 29 (fig. 3) a zone of leached gray clay from 12 to 18 inches thick separates the two tills. The Kansan till that overlies this thin zone is calcareous to its base. The upper part of the Nebraskan till that underlies it is leached of carbonate to depths of 12 to 60 inches. A buried soil is not identifiable morphologically beneath the clay in these sections.

In cuts 30 and 31 (fig. 3) the leached clay is from 60 to 72 inches thick and separates the upper calcareous Kansan till from the lower calcareous Nebraskan till. At station 1,100 in cut 31 the basal part of the lake clay is calcareous and contains limestone pebbles as well as calcareous, aquatic, gastropod shells. Below this horizon a gray, sandy, leached, coarse angular blocky, till-like sediment is 38 inches thick and grades downward into a leached, sandy gravel. The sand and gravel zone is 15 inches thick and rests upon a layer of cobbly gravel. The cobbly gravel occurs as a stone line throughout the cut and mantles calcareous Nebraskan till.

The till-like sediment and sand and gravel are believed to be a sediment deposited on an erosion surface on Nebraskan till. The cobbly gravel stone line is a lag gravel and is evidence of an erosion surface on Nebraskan till. The leached translocated sediment separates the underlying calcareous Nebraskan till from the overlying calcareous Aftonian lake clay. A weathered zone separates the till from the clay.

Thus along the traverse, buried soils, leached sands and gravels, and a forest bed associated with a buried Humic-Gley soil fulfill Kay's (25, pp. 141-146) requirements, and separate the lower till from the overlying sediments. On these bases the till is classified and correlated as Nebraskan in age.

Aftonian Clay

Clay interbedded between tills of Nebraskan and Kansan age and stratigraphically separated from the tills by buried soils, weathering zones, and erosion surfaces establishes the clay as Aftonian in age. The Aftonian clay crops out in cuts 9, 28, 29, 30, and 31 (pl. I). Its thickness ranges from 12 to 18 inches in cuts 9, 28, and 29 to 60 to 72 inches in cuts 30 and 31 (fig. 3).

The sediment is gray (10YR 5/1-6/1), heavy, plastic, coarse angular blocky silty clay. Slickensides are prominent on the surfaces of the blocks and indicate intensive movement within the mass. Such a plastic sediment between tills affords excellent conditions for earth movement (46).

In cut 30 the plastic nature of the Aftonian clay is demonstrated by the protuberances of clay that extend upward 10 to 15 feet into the overlying Kansan till. Their formation may be the result of adjustment to hydrostatic stress as the Kansan glacier overrode the clay, which resulted in plastic deformation and injection of clay upward into the capping till.

In cut 31 deformation by plastic flow and shear is localized to the clay. The bed contains 46 percent clay. In contrast, the calcareous Nebraskan till below contains only 30 percent, and the calcareous Kansan till above only 26 percent. Construction of the railroad cut permitted a release of the stress developed by the 35 feet of overburden composed of Kansan till and Wisconsin loess. As a result, plastic deformation of the clay in the north face caused a pseudo-mudflow that moved down the face of the cut.

On the south face of the cut a large earthslide developed (fig. 4). In July 1953 primary fractures that delineated the slump block extended from the base of the Aftonian clay up the face of the cut to the top of the Wisconsin loess. The distance along the face of the cut between the primary fractures was 225 feet. A critical shear surface on the clay and lower till contact projected into the cut and cropped out vertically at the top of the cut. Displacement of the slump block along the critical surface at the top of the cut was 4 feet. In October 1953 the toe of the slump block had moved 10 to 15 feet onto the grade of the railroad. In April 1954 extensive displacement had taken place. Several times during the intervening period slumped material had to be removed from the railroad right-of-way. Vertical displacement along the critical surface at the top of the cut was 10 to 15 feet (fig. 4).

The difference in mass permeability of the two sediments probably localized the critical surface at the contact between the clay and the lower till. The Aftonian clay has a coarse angular blocky structure in its lower part, with individual blocks 2 to 3 inches in largest dimension. The upper part of the clay has a fine to medium angular to subangular blocky structure. The blocks are $\frac{1}{4}$ to $\frac{1}{2}$ inch in largest dimension. Thus, adequate channels are available for ground water seepage through the clay although the clay matrix is relatively impermeable.

The underlying Nebraskan till has a coarse angular blocky structure. The blocks have dimensions of 12 to 16 inches. Ground water seeping through the overlying clay is temporarily impeded in its downward movement because of the discontinuity in available channels at the contact. Lateral flow was shown by a line of seepage along the contact on the face of the cut. Thus, the coincidence of stratigraphy and discontinuity of lithology was responsible for the localization of the critical surface in the stability of the cut slope.

Lithologic characteristics of the Aftonian clay and presence of aquatic fossil mollusks in cut 31 show that it is a water-laid deposit, possibly of a lake environment. Similar lithologic and stratigraphic sections 15 miles west of this area in Pottawattamie County indicate a considerable geographic distribution that precludes a river environment.

The Aftonian clay has the same mineral components (table 5) as the Nebraskan till but in proportions that suggest that the material was more weathered, probably before deposition. Feldspar, mica, and weatherable heavy minerals (amphiboles and pyroxenes) in fine sand and silt are in smaller proportions than in Nebraskan till. The clay fraction is montmorillonite, with minor amounts of illite and kaolin.

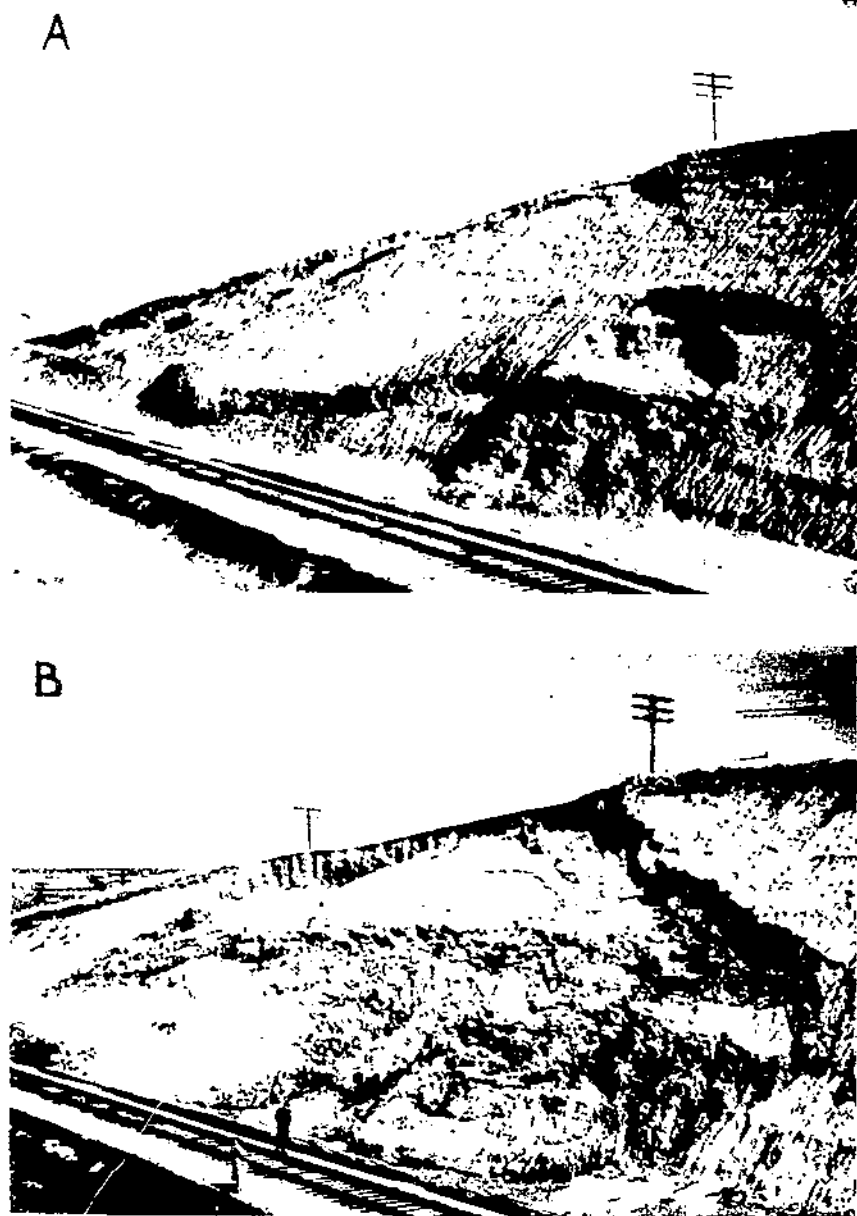

FIGURE 4.—Earthslide in cut 31, September 1953 (A) and April 1954 (B).

TABLE 5.—Proportions of nonopaque heavy minerals, sample 13, cut 31

Mineral	Size-fractions	
	50-100 μ	20-50 μ
	Percent	Percent
Epidote.....	30	41
Tourmaline.....	10	4
Zircon.....	12	14
Garnet.....	15	5
Hornblende.....	15	3
Titanium minerals.....	10	28
Miscellaneous.....	5	3

Kansas Till

Kansan till is the most widespread glacial drift in southwestern Iowa (25, pp. 215-217). It is exposed in 31 of the 58 cuts along the traverse (pl. I).

Though it does not differ appreciably from the Nebraskan texturally or mineralogically (table 2), it does have a distinctive weathering profile that aids in deciphering the geomorphic history of the landscape.

A soil profile at the top grades downward into a zone that is yellowish brown (10YR 5/6-5/8) and leached of carbonate. This zone is designated as oxidized and leached Kansan till. It grades downward into till similar in color but different in that it contains primary carbonate in the form of limestone and dolomite particles and secondary carbonate in the form of calcareous concretions. This zone is designated oxidized and unleached Kansan till. It grades downward into dark gray (10YR 4/1) and very dark gray (10YR 3/1) till that contains primary carbonate. A designation of unoxidized and unleached Kansan till is given to this zone.

The Kansan till overlies Nebraskan till in cuts G and H and Aftonian clay in cuts 9, 28, 29, 30, and 31. There is unconformable relationship along the contact between the two tills in cut G. At the west end, the unoxidized and unleached Kansan till rests on the buried Humic-Gley paleosol in the uppermost part of the oxidized and leached Nebraskan till. Eastward in the cut it overlies oxidized and unleached Nebraskan till. Thus, angular truncation of the weathering profile in Nebraskan till shows the stratigraphic superposition of the Kansan.

The Kansan till (pl. I) is overlain by Yarmouth clay in cuts 3, 6, 12, 22, 23, and 27, by Loveland loess in cuts 33, 37, 39, and 50, and by Late Sangamon pedi-sediment in cuts 1, 10, 28, 29, 30, 32, 46, A, B, C, F, G, and H, or the basal Farmdale increment of the Wisconsin loess in cuts 2, 8, 9, 31, 40, D, and E.

In cut 3 the Kansan till is separated from the overlying Yarmouth clay by a buried soil in the uppermost part of the till (fig. 5). A distinct white to pale yellow band that shows clearly in the face of the cut appears in the field to be the A₂ horizon of

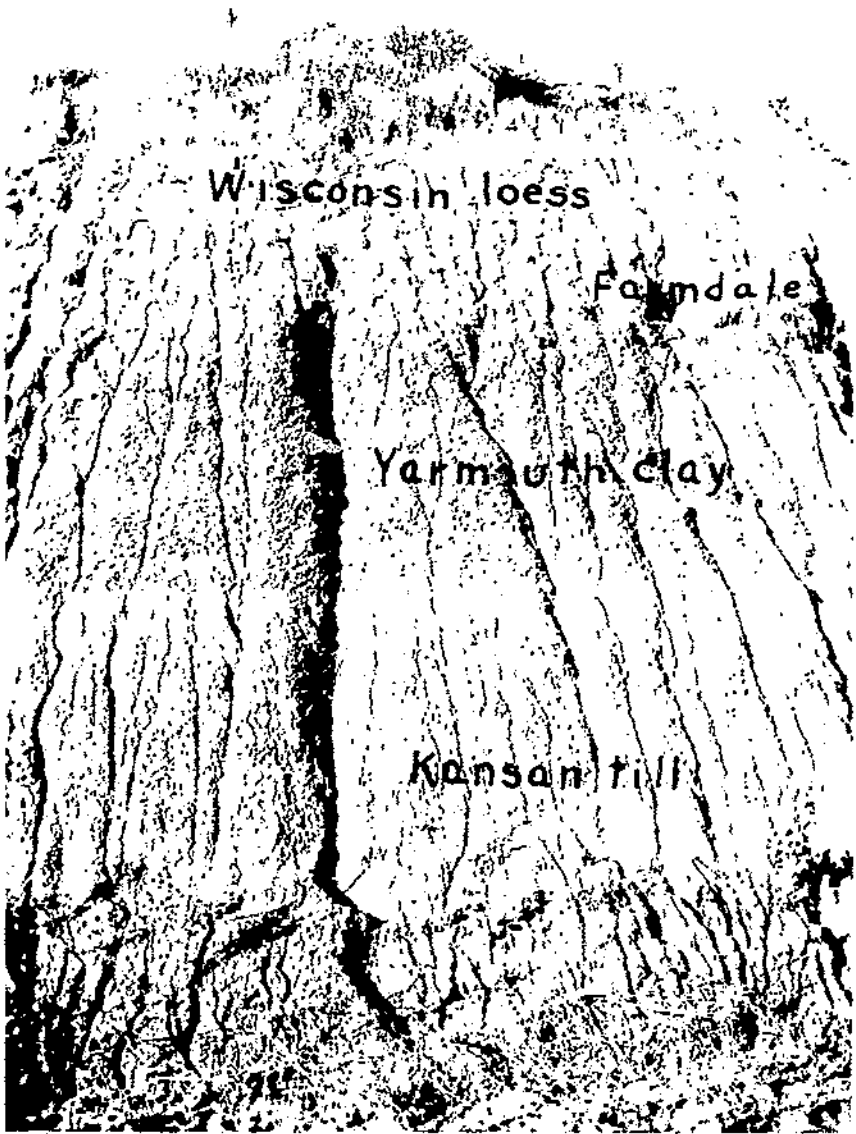

FIGURE 5.—Stratigraphic relationships of Kansan till, Yarmouth clay, and Wisconsin loess, cut 3. A Yarmouth paleosol separates the till from the clay. There is a Late Sangamon paleosol in the uppermost part of the Yarmouth clay and a third paleosol in the upper part of the Farmdale loess.

this profile. However, many of its characteristics as determined from a laboratory sample indicate that it is probably a part of the Yarmouth sediment above it. Its heavy mineral separates resemble those from till more than those from the clay, except

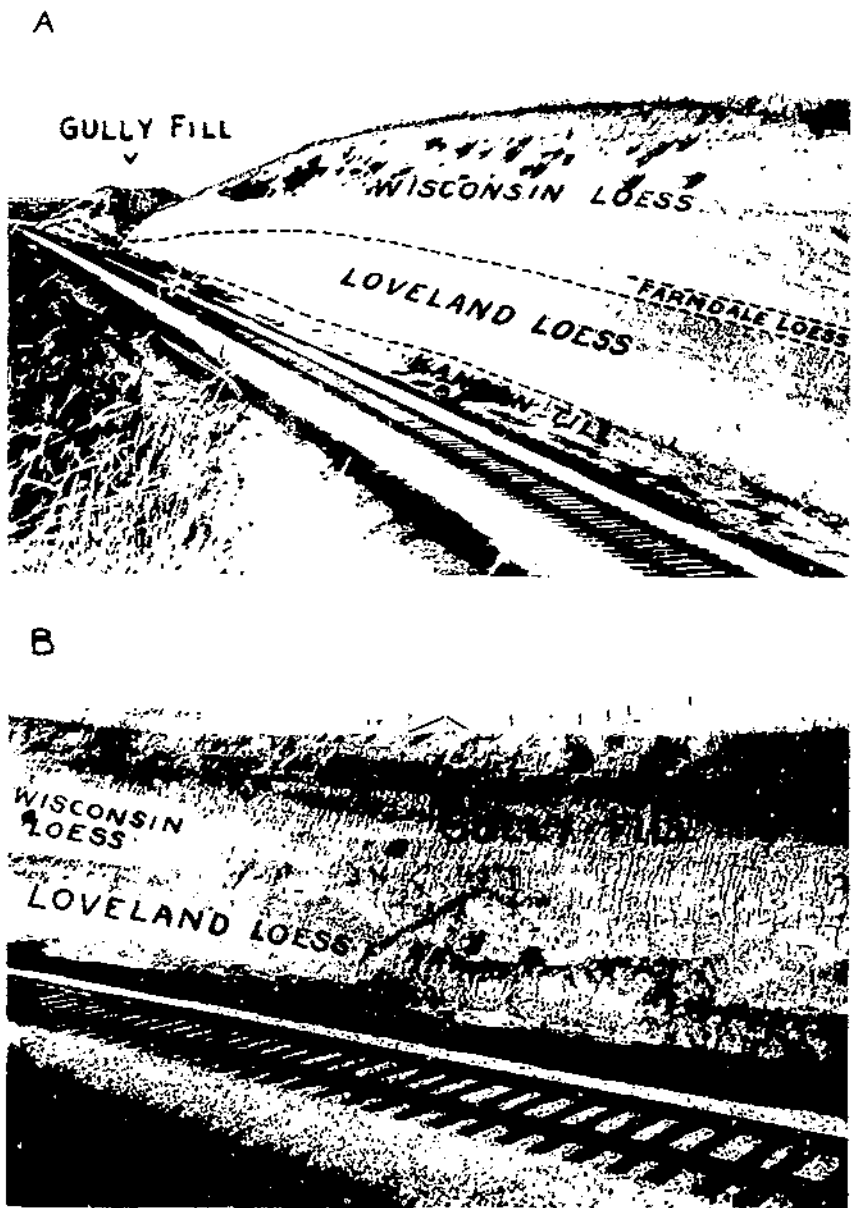

FIGURE 6.—Stratigraphic relationships of Kansan till, Loveland loess, and Wisconsin loess, cut 39. A, A Yarmouth paleosol occurs in the upper part of the Kansan till and a Sangamon paleosol in the upper part of the Loveland loess. A third paleosol is in the upper part of the Farmdale loess. Note the gully fill that truncates the Wisconsin and Loveland loesses. B, Detail of gully fill. The base of the fill is dated at $6,800 \pm 300$ years by radiocarbon analysis.

for a somewhat higher tourmaline content. A high hornblende content in the coarse silt in relation to that of the very fine sand indicates that the material has been only slightly weathered. The light mineral separate had a higher feldspar content than either the till or clay and about 10 percent of the fine silt fraction consists of opaline siliceous particles. Most of these particles are worn and broken, but many of them could be identified as remains of aquatic plants and animals.

The particle size distribution is different from the till; the sample contains a little grit and coarse sand but is very high in silt and low in medium and fine sand as compared with the till. This sediment overlies a B horizon in the uppermost part of the underlying Kansan till. Apparently the A horizon was stripped during the lake episode that gave rise to the silt and clay.

The buried soil in the uppermost part of the Kansan till is:⁶

Section A:

B _{1ab} 0-14 inches below base of Yar- mouth clay	Light gray (5Y 7/2) to light olive gray (5Y 6/2) silty clay loam; moderate fine subangular blocky; hard when dry, friable when moist; clay skins prominent; gritty; leached.
B _{2ab} 14-40 inches	Light gray (5Y 7/2) to light olive gray (5Y 6/2) clay; strong coarse angular blocky; very hard when dry, very firm when moist; moderate amount medium-sized distinct light olive brown (2.5Y 5/6) mottles; clay skins prominent; gritty; leached.
B _{3ab} 40-54 inches	Pale yellow (5Y 7/2.5) to pale olive (5Y 6/2.5) light silty clay; weak coarse subangular blocky; very hard when dry, very firm when moist; medium-sized light olive brown (2.5Y 5/6) mottles common; clay skins moderately prominent; gritty; leached.
C _{3genh} 136-198 inches	Light gray (5Y 7/2) to light olive gray (5Y 6/2) clay loam; massive; hard when dry, firm when moist; gritty to cobbly; calcareous till.

Such a buried soil in Kansan till is excellent evidence of a disconformity between the Kansan till and the overlying Yar-mouth clay.

A buried soil in the uppermost part of the Kansan till separates the till from the overlying Loveland loess (fig. 6). The buried soil is:⁷

Section B:

A _{1b} 0-18 inches below base of Love- land loess	Pale brown (10YR 6/3.5) to brown (10YR 5/3) light silty clay loam; moderate fine angular blocky; hard when dry, friable when moist; clay skins distinct; gritty; leached. (Lower 3 inches may be weakly developed A ₂ horizon.)
B _{1b} 18-43 inches	Pale brown (10YR 6/3) to brown (10YR 5/3) silty clay; moderate coarse angular blocky; hard when dry, very firm when moist; clay skins prominent; gritty; leached.
B _{2b} 43-73 inches	Light yellowish brown (10YR 6/4) to yellowish brown (10YR 5/4) clay; strong coarse angular blocky; very hard when dry, very firm when moist; clay skins prominent; very gritty; leached.
B _{3b} 73-104 inches	Very pale brown (10YR 7/2.5) to pale brown (10YR 6/3) light clay; weak coarse angular blocky; very hard when dry, very firm when moist; clay skins prominent; gritty to pebbly; leached.

⁶ Soil description modified from notes of A. J. Cline.

⁷ Soil description modified from notes of A. J. Cline.

C _b 104-144 inches	Variegated light olive brown (2.5Y 5/6) and white (2.5Y 8/2) to light olive brown (2.5Y 5/6) and light brownish gray (2.5Y 6/2) heavy clay loam; massive; clay skins sparse; gritty to cobbly; oxidized and leached till to base of cut.
-------------------------------------	--

The Loveland loess that overlies this buried profile in Kansan till is of Illinoian age (33, pp. 601-602). A buried soil of such morphology in the uppermost part of the Kansan till must be the result of weathering during the Yarmouth interglacial age.

Where the Kansan till has been beveled by a younger erosion surface, the till is generally capped by a stone line that in turn is overlain by various thicknesses of a lighter textured sediment, pedisidement.

In the eastern part of the traverse (pl. I: D, E) in an area beyond the limits of deposition of Yarmouth clay and Loveland loess, the basal Farmdale increment of the Wisconsin loess overlies a buried soil in Kansan till.

Samples from two buried profiles in Kansan till, cuts 3 and 31, were examined to determine their mineralogical composition (table 6). Components are the same as those of the other Pleistocene deposits but with some variations in proportions. Feldspar content of the fine sand is 15 to 20 percent, decreasing to a few percent in the fine silt. Feldspar content of samples taken as C horizons of buried soils is considerably higher than that of samples from B horizons especially in the silt fractions. Mica is also fairly common in C horizons but scarce in upper horizons.

Heavy mineral compositions are somewhat erratic. Proportions of hornblende show that the A and B horizons of the buried soils are more weathered than the C horizons.

The clay fraction of all samples from both profiles contains the same components, but there are some small variations possibly due to weathering. In samples 21 and 5 both C horizons are the same; they are dominated by montmorillonite but contain moderate amounts of illite and about 10 percent kaolin. In the upper horizons of both profiles montmorillonite increases and the illite decreases or shows less organized crystallinity, probably due to formation of randomly interstratified montmorillonite layers by weathering.

TABLE 6.—Proportions of nonopaque heavy minerals of Kansan till

Mineral	Cut 31						Cut 3					
	Sample 15		Sample 14		Sample 21		Sample 6		Sample 4		Sample 5	
	50-100 μ	20-50 μ	50-100 μ	20-50 μ	50-100 μ	20-50 μ	50-100 μ	20-50 μ	50-100 μ	20-50 μ	50-100 μ	20-50 μ
	<i>Percent</i>	<i>Percent</i>	<i>Percent</i>	<i>Percent</i>	<i>Percent</i>	<i>Percent</i>	<i>Percent</i>	<i>Percent</i>	<i>Percent</i>	<i>Percent</i>	<i>Percent</i>	<i>Percent</i>
Epidote.....	40	36	40	44	35	40	30	34	30	34	25	39
Tourmaline.....	5	6	7	7	3	9	6	7	2	3	3	4
Zircon.....	10	16	12	15	8	13	6	10	5	14	6	7
Garnet.....	10	5	12	7	8	13	15	9	10	8	12	8
Hornblende.....	28	16	20	11	35	10	30	22	40	13	45	20
Titanium minerals.....	5	18	5	12	5	14	4	14	4	24	3	19
Miscellaneous.....	3	3	7	5	5	2	10	5	4	4	4	4

Yarmouth Clay

Along the traverse between the East and West Nishnabotna Rivers, a light gray to light olive gray, heavy, plastic, silty clay overlies the Kansan till and is separated from it by a buried soil in the uppermost part of the Kansan till (fig. 5).

The clay is a light gray (2.5Y 7/2) to light olive gray (2.5Y 6/2) in zones below the buried soil. The clay has a very coarse subangular blocky structure, is extremely hard when dry, and is very firm when moist. Slickensides, grooves, and striations occur on the faces of the subangular blocks. The clay in most cuts is leached of carbonate. However, in cut 11 the upper 10½ feet is leached of carbonate, whereas the lower 10½ feet is slightly calcareous. The textures of the zones of the bed below its paleosol are very uniform and are a heavy silty clay to clay (fig. 7).

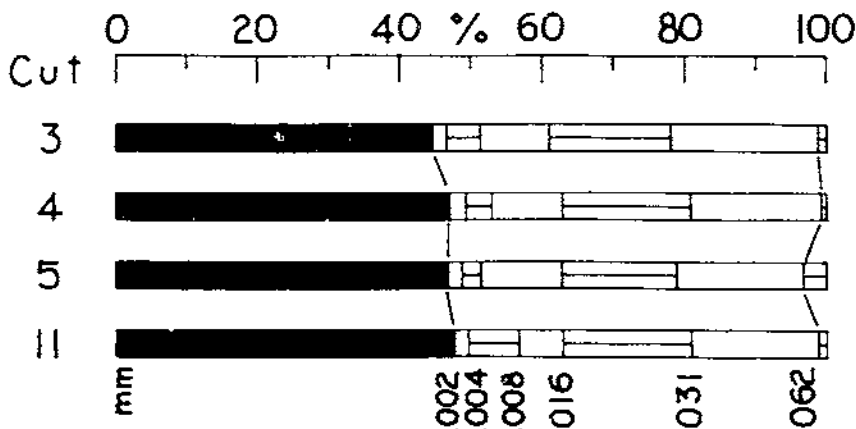

FIGURE 7.—Textures of Yarmouth lake clay, cuts 3, 4, 5, and 11.

The clay bed occurs in many cuts along the traverse (pl. I: 3, 4, 5, 6, 11, 12, 14, 15, 21, 22, 23, 24, 27), but through a distance of 13 miles it is restricted to an elevation of 1,266 to 1,299 feet (table 7). The elevations of the bottom of the clay, where the bottom is exposed (3, 6, 12, 22, 23, 27), are from 1,266 to 1,279 feet. Such accordance of elevations suggests that the clay may have been one continuous lacustrine deposit on the Kansan till plain.

A problem in classification and correlation arises when these clay beds are compared with those exposed between two tills in cuts 9, 28, 29, 30, and 31. However, at no place in the sequence of cuts 3 to 27 was till found above the clay. The clays in the sequence of cuts 9 to 31 fall within an elevation range of 1,193–1,235 feet. This range is 60 to 70 feet below that of the sequence of cuts 3 to 27. The upper till of cut 28 that is above a clay is accordant with the till of cut 27 below a clay. Similarly, the upper till in cut 9 that is above a clay is accordant with a till in cut 10 and in cut 11 that is below a clay. Although the lithologies of the clays of both sequences are similar, the stratigraphic relationships, the grouping of beds into different elevation ranges,

TABLE 7.—Elevation and thickness of Yarmouth and Aftonian clay beds

Cut	Elevation		Thickness
	Bottom	Top	
Yarmouth	<i>Feet</i>	<i>Feet</i>	<i>Feet</i>
3.....	1,266	1,277	11
4.....	(1,279)	1,282	3
5.....	(1,273)	1,299	26
6.....	1,269	1,281	12
11.....	(1,270)	1,291	21
12.....	1,270	1,274	4
14.....	(1,282)	1,285	3
15.....	(1,293)	1,299	6
21.....	(1,286)	1,291	5
22.....	1,279	1,291	12
23.....	1,277	1,283	6
24.....	(1,290)	1,298	8
26.....	(1,282)	1,285	3
27.....	1,268	1,275	7
Aftonian			
9.....	1,233	1,235	2
28.....	1,219	1,221	2
29.....	1,216	1,218	2
30.....	1,205	1,212	7
31.....	1,193	1,199	6

¹ Parentheses mean not exposed.

and the juxtaposition of till horizons determined by direct tracing suggest that the sequences represent different stratigraphic horizons. They have been designated the upper bed-Yarmouth and the lower bed-Aftonian.

The Yarmouth clay has wide geographic distribution. Sections have been recorded 6 miles south of the traverse in Pottawattamie County and 10 miles north in Shelby County. In some localities the clay was previously designated as "gumbotil."

Separation of the clay from the underlying Kansan till is shown in figure 5. The Yarmouth clay is overlain by the Loveland loess (pl. I; cuts 4, 15, 21, 26) or by the basal Farmdale increment of the Wisconsin loess (cuts 3, 5, 6, 11, 12, 14, 23, 24). A buried soil in the uppermost part of the clay separates it from the overlying Loveland loess as in cut 26:^a

Section C:

- A_{1b} 0-17 inches Very pale brown (10YR 7/3) to pale brown (10YR 6/3) silty clay loam; weak coarse granular; very hard when dry, very firm when moist; abundant clay skins; many large prominent yellowish brown (10YR 5/8) mottles; slightly gritty; leached.
- A_{3b} 17-30 inches Light brownish gray (10YR 6/2.5) to grayish brown (10YR 5/2.5) heavy silty clay loam; weak fine subangular blocky; very hard when dry, firm when moist; clay skins prominent; slightly gritty; leached.
- B_{21b} 30-42 inches Pale brown (10YR 6/3) to brown (10YR 5/3) silty clay; moderate fine subangular blocky; very hard when dry, very firm when moist; clay skins prominent on aggregates; slightly gritty; leached.

^a Soil description modified from notes of A. J. Cline.

- B_{21b} 42-62 inches Light brownish gray (10YR 6/2.5) to grayish brown (10YR 5/2.5) clay; strong medium angular blocky; very hard when dry, very firm when moist; clay skins on aggregates very prominent; yellowish brown (10YR 5/8) mottles common; very slightly gritty; leached.
- B_{21c} 62-80 inches Light gray (10YR 7/2) to light brownish gray (10YR 6/2) clay; strong coarse angular blocky; very hard when dry, very firm when moist; clay skins on aggregates prominent; yellowish brown (10YR 5/8) mottles common; slightly gritty; leached to base of cut.

Where the Yarmouth clay is overlain by the basal Farmdale increment of the Wisconsin loess, the two beds are separated on the bases of differences in lithologies as well as by the occurrence of a buried soil in the uppermost part of the Yarmouth clay (fig. 8). For example, a section in cut 11 is:

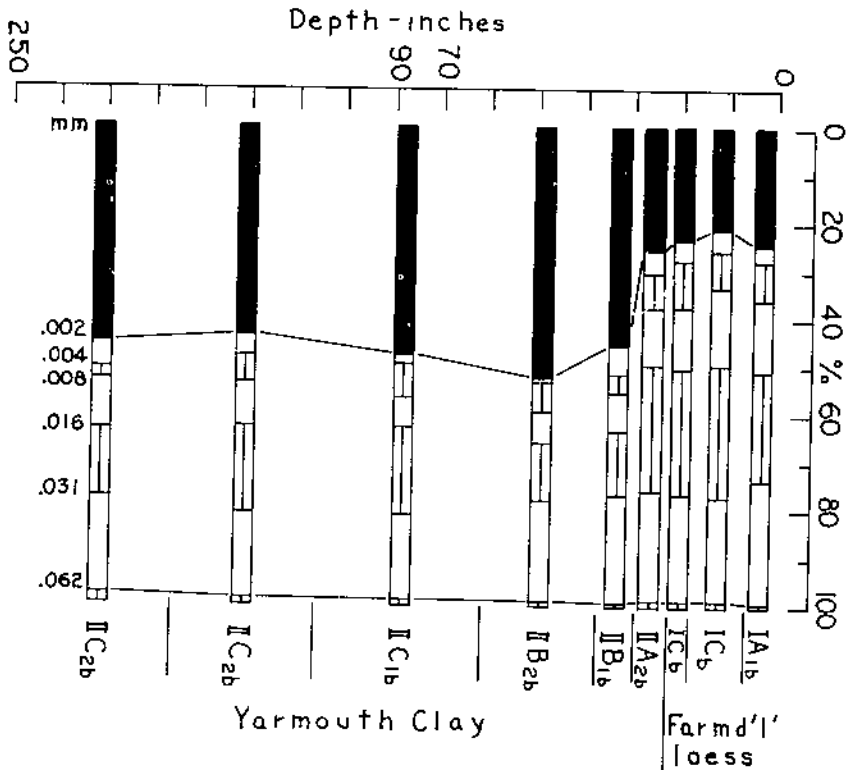

FIGURE 8.—Textures of the Farmdale paleosol and loess, and the Yarmouth clay and its surficial Late Sangamon paleosol, cut 11.

Section D:

Wisconsin loess:	
Oxidized and leached 0-110 inches	Yellowish brown (10YR 5/6-5/8) silt loam; massive; friable; leached.
Deoxidized and unleached 110-194 inches	Light gray (2.5YR 7/1) silt loam; massive; friable; iron oxide segregated in tubules and concretions; calcareous.
Oxidized and unleached 194-218 inches	Yellowish brown (10YR 5/8) silt loam; massive; friable; fossiliferous, calcareous.
Deoxidized and leached 218-260 inches	Gray (10YR 5/1) to light gray (10YR 6/1) silt loam; massive; friable; iron oxide segregated in tubules and concretions; leached.
Ferrisdale loess:	
IA _b ⁹ 260-266 inches	Dark yellowish brown (10YR 4/4) to dark brown (10YR 4/3) silt loam; weak fine granular; friable; leached.
IC _b 266-289 inches	Yellowish brown (10YR 5/6) silt loam; weak fine granular; friable; leached.
Yarmouth clay:	
IIA _{2b} 282-289 inches	Brown (10YR 5/3) to dark brown (10YR 4/3) silt loam; strong medium granular; friable when dry, moderately plastic when moist; clay skins on aggregates common; leached.
IIB _{1b} 289-297 inches	Grayish brown (10YR 5/2) light silty clay; strong medium subangular blocky; hard when dry, firm but plastic when moist; clay skins on aggregates prominent; leached.
IIB _{2b} 297-321 inches	Grayish brown (10YR 5/2) to brown (10YR 5/3) heavy silty clay; strong medium angular blocky; very hard when dry, very firm but plastic when moist; clay skins on aggregates very prominent; leached.
IIC _{1gb} 321-382 inches	Light gray (10YR 7/1-7/2) silty clay; strong medium angular blocky; hard when dry, firm but plastic when moist; slickensides on faces of blocks; leached.
IIC _{2ab} 382-442 inches	Light gray (10YR 6/1) to light brownish gray (10YR 6/2) light silty clay; coarse angular blocky; hard when dry, firm but plastic when moist; slickensides on surfaces of blocks; slightly calcareous.
IIC _{3ab} 442-502 inches	Light gray (10YR 7/1) silty clay; coarse angular blocky; hard when dry, firm but plastic when moist; slickensides on surfaces of blocks; slightly gritty; slightly calcareous to base of cut.

In this section there is no Loveland loess above the Yarmouth clay. It has been stripped (cf.: cuts 4, 13, 14, 15, 16, 17). In the uppermost part of the clay is a soil on the Late Sangamon erosion surface.

Samples for mineralogical study (table 8) were collected from buried soils formed in the Yarmouth clay in cuts 3 and 26. A sample of gray clay under a Humic-Gley profile below Loveland loess was collected in cut 3. Sample 2 from cut 3 was from the upper B of a soil in the clay and sample 3 about 4 feet below sample 2 from the C horizon. In cut 26 sample 8 was from the upper part of the B horizon and sample 7 from the C horizon.

The clay contains the same general assortment of minerals as the tills and loesses but in somewhat different proportions. All the samples contain 15 to 20 percent feldspar in the sand with percentages decreasing in the finer silt. Mica is fairly common,

⁹ Roman numeral preceding letter-horizon symbol indicates difference of parent material.

amounts ranging from 3 to 5 percent in the fine sand and coarse silt. Feldspars appear somewhat etched and corroded as if weathered.

The composition of the heavy separates indicates some local variation in the origin of the material. In some respects it is intermediate between till and Loveland loess. Sample 2 contains a large proportion of fresh hornblende and has tourmaline, zircon, and garnet ratios in the very fine sand that are similar to those in the Farmdale loess. This horizon is transitional and more like Farmdale loess than an A or B horizon in the Yarmouth clay. The high zircon and low garnet content of the 50- to 100-micron fraction in sample 3 is unique among all the samples studied; sample 3 also had the highest sphene, rutile, and anatase content of any sample. The low content and the etched and pitted appearance of the hornblende indicates a well-weathered material. However, some of the hornblende was fresh so some of the weathering of hornblende must have taken place before deposition.

Proportions of tourmaline, zircon, and garnet in samples 7 and 8 are similar to those in the buried soil in Kansan till in cut 31. Hornblende content is low, indicating a strongly weathered material, but again there are indications that most of the weathering was predepositional. In addition to the fresh feldspar and fresh hornblende, the small difference between samples 7 and 8 suggests that little weathering occurred after deposition. Both samples have much lower hornblende content than soils in Loveland loess or Kansan till. However, only B and C horizons of till soils were sampled. Presumably the greatest weathering would have occurred in A horizons that may have made the greatest contribution as source of the Yarmouth clay.

The clay fraction of all the samples is dominantly montmorillonite and has small amounts of disordered illite and traces of kaolin.

TABLE 8.—Proportions of nonopaque heavy minerals of Yarmouth clay

Mineral	Cut 3				Cut 26					
	Sample 2		Sample 3		Sample 8		Sample 7		Sample 22	
	50-100 μ	20-50 μ	50-100 μ	20-50 μ	50-100 μ	20-50 μ	50-100 μ	20-50 μ	50-100 μ	20-50 μ
Epidote.....	33	29	43	37	45	36	40	35	40	39
Tourmaline.....	4	5	9	1	5	3	7	4	6	7
Zircon.....	6	18	12	19	12	18	14	20	10	10
Garnet.....	7	8	4	4	10	8	12	10	12	11
Hornblende.....	43	19	18	2	5	5	7	2	15	5
Titanium minerals.....	6	19	9	33	15	27	15	28	5	22
Miscellaneous.....	4	3	4	2	5	3	4	2	10	7

Loveland Loess

Loveland loess occurs in many of the sections along the traverse (pl. I). In cut 50 in a zone 73 to 266 inches below the top of the solum in the uppermost part of the Loveland, the loess is a brown (10YR 5/3) silt loam to light silty clay. It is massive and friable, is leached of carbonate, and contains 28 to 29 percent clay ($<2\mu$). However, in cut 39 at a depth of 120 to 160 inches below the top of the solum the loess is a light yellowish brown (10YR 6/4) to yellowish brown (10YR 5/4) heavy silty clay loam to light silty clay. It is massive, hard when dry and friable when moist, and leached of carbonate. It contains 33 to 35 percent clay. Small tubular channels that mark the former positions of plant roots have clay-flow surfaces. Thus, alteration and translocation of mineral matter have taken place deep within the loessial sediment.

The texture of the Loveland loess becomes finer with distance along the traverse from west to east (fig. 9). The sample sites

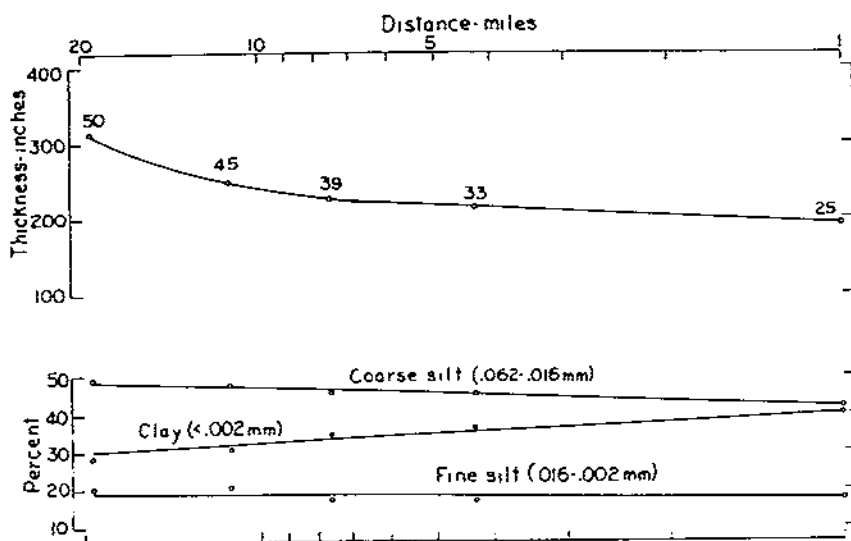

FIGURE 9.—Variation of thickness and texture of Loveland loess along the traverse from west to east.

(50, 45, 39, 33, 25) are restricted to primary and secondary divide positions. Ruhe (47, pp. 665-667) has shown that regional characteristics of the Wisconsin loess are restricted to such topographic positions. The same relationships are true of the Loveland loess. The coarser silt fraction (62-16 μ) progressively decreases with distance along the traverse (fig. 9). Ruhe (47, p. 666) found a similar relationship in the particle-size distribution of Wisconsin loess at the same sample sites. Smith (63, p. 153) previously had found similar relationships in the Peorian loess in Illinois. However, the finer silt fraction (16-2 μ) in the Loveland loess decreases with distance along the traverse. Ruhe,

in the Wisconsin loess at the same sample sites, and Smith, in the Peorian loess in Illinois, found that the finer silt fraction increased with distance.

The thickness of the Loveland loess decreases along the traverse from a maximum of 311 inches in cut 50 to 155 inches in cut 4 (fig. 9). Such variation in thickness is characteristic of the Wisconsin loess at the same sample sites. Similar thickness-distribution relationships were found previously in the Peorian loess in Illinois by Smith (63, pp. 156-163). When the Wisconsin loess-thickness curve is superimposed on the Loveland loess-thickness curve, an excellent parallelism is noted (fig. 17). Such parallelism of curves suggests a possible similar source area for both loesses. Although the thickness of the loesses differ at specific sample sites along the traverse, the relative change of thickness of one loess

TABLE 9.—Elevations at which Loveland loess occurs or should occur along traverse

Divide unit		Elevation range		
Order	Segment of traverse	Present	Absent	
II	Cuts 1-7:	Feet	Feet	
	East flank (3-1)			1255-1277
	Crest (4)			1280-1293
II	West flank (5-7)	1218-1285		
	Cuts 8-12:			
	East flank (10-8)	1220-1252		
I	Crest (11)	-- --1285		
	West flank (12)	-- --1275		
	Cuts 13-22:			
II	East flank (16-13)	-- --1260 (13) ²	-- --1285 (14)	
	Crest (17)	1300-1312		
	West flank (18-22)	-- --1321		
II	Cuts 23-31:	1290-1312	-- --1290 (22)	
	East flank (24-23)		1285-1297	
	Crest (25)	-- --1305		
II	West flank (26-31)	1278-1290 (26)	1200-1278	
	Cuts 32-35:			
	East flank (32)		-- --1203	
II	Crest (33)	1210-1235	-- --1210	
	West flank (34-35)	1210-1225		
	Cuts 36-39:			
I	East flank (38-36)	1180-1225		
	Crest (39)	1237-1255		
	West flank (none)			
I	Cuts 40-46:			
	East flank (42-40)	1272-1292	-- --1222 (40)	
	Crest (44)	-- --1293		
I	West flank (45-46)	-- --1278	-- --1216 (46)	
	Cuts 48-50:			
	East flank (49-48)	-- --1204	-- --1176 (48)	
	Crest (50)	1210-1230		
	West flank (none)			

¹ Numbers in parentheses refer to cut numbers (pl. I).

² Cut 13 is the only anomalous relationship throughout the traverse. Dashed lines indicate base of loess not exposed.

along the traverse is similar to that of the other loess. A ratio of loess-thickness decrease of one third applies to both loesses.

The source area of the Wisconsin loess is believed to be the Missouri River Valley (47, p. 667). Correspondingly, the source area of the Loveland loess also must have been the Missouri River Valley. Such a conclusion is not inconsistent with recent geologic evidence (75) which shows that the Missouri River must have carried Illinoian outwash.

Divide units are designated as primary or secondary dependent upon whether drainage is to a primary stream draining directly to the Missouri River or to a secondary stream draining to a primary stream. The divide unit in the traverse area of north-south drainage is composed of (1) a crest (the highest part of the landscape between drainages), (2) an east flank (the sloping landscape from the crest to a drainage to the east), and (3) a west flank (from the crest to a drainage to the west).

The complexity of the relationship of occurrence of Loveland loess to elevations on divide units shown in table 9 indicates: (1) That the Loveland loess was a blanket deposit that mantled the entire landscape regardless of topographic position, and (2) that the absence of Loveland loess from flank positions is a result of post-Loveland erosion. Thus the presence or absence of Loveland loess on divide-unit flanks is an important aid in reconstructing the geomorphic history of the area.

Where Loveland loess overlies either Kansan till or Yarmouth clay, it is separated from these by a buried soil. The Loveland is overlain by the basal Farmdale increment of the Wisconsin loess, and these two deposits are separated by a strongly developed buried soil. In cut 39, 364 inches of Wisconsin loess overlie the Farmdale, which in turn overlies the Loveland:¹⁰

Section E:

Farmdale:

IA_{1b} Light brownish gray (10YR 6/2) to dark grayish brown (10YR 4/2) silt loam; moderate coarse granular; friable; aggregates have gray coatings; abundant medium yellowish brown (10YR 5/6) mottles; leached.

IC_b 9-43 inches Light brownish gray (10YR 6/2) silt loam; weak coarse granular; friable; aggregates have brown to strong brown coatings; leached.

Sangamon soil in Loveland loess:

IIA_{2b} 43-51 inches Variegated white (10YR 8/1) and strong brown (7.5YR 5/6) to light gray (10YR 7/2) and reddish brown (5YR 4/4) silt loam; weak coarse platy to coarse granular; hard when dry, firm when moist; leached.

IIB_{1b} 51-71 inches Variegated white (10YR 8/2) and yellowish red (5YR 4/6) to light gray (10YR 7/2) to dark reddish brown (5YR 3/4) silty clay loam; reddish colors occur as aggregate coatings; strong fine angular blocky; hard when dry, firm when moist; clay skins prominent; leached.

IIB_{2b} 71-81 inches Very pale brown (10YR 7/3) to pale brown (10YR 6/3) silty clay; dark reddish brown (5YR 3/4) coatings on aggregates give horizon a red color; strong medium angular blocky; very hard when dry, very firm but plastic when moist; clay skins abundant; leached.

¹⁰ Section description modified from notes of A. J. Cline.

IIB _{3b} 81-129 inches	Light gray (10YR 7/2) to light brownish gray (10YR 6/2.5) silty clay loam; weak coarse angular blocky; hard when dry, firm when moist; abundant yellowish brown (10YR 5/6) mottles; clay skins prominent; leached.
IIC _b 129-216 inches	Light yellowish brown (10YR 6/4) to yellowish brown (10YR 5/4) heavy silt loam; massive; hard when dry, friable when moist; tubules with clay skins common; leached.
Intra-Illinoian soil in Loveland loess:	
IIA _{1b} 216-228 inches	Pale brown (10YR 6/3) to brown (10YR 5/3) silt loam; weak coarse granular; hard when dry, friable when moist; few clay skins; leached.
IIA _{2b} 228-239 inches	Pale brown (10YR 6/3.5) to brown (10YR 5/3.5) silt loam; weak fine subangular blocky; hard when dry, friable when moist; clay skins common; leached.
IIIB _{2b} 239-260 inches	Light yellowish brown (10YR 6/3.5) to yellowish brown (10YR 5/3.5) heavy silty clay loam; weak medium subangular blocky; hard when dry, firm when moist; clay skins prominent; leached.
IIIC _b 260-270 inches	Pale brown (10YR 6/3) to yellowish brown (10YR 5/3.5) silt loam; weak fine subangular blocky; hard when dry, friable when moist; clay skins common; leached; to base of cut.

The IIIC_b horizon (260-270 inches) overlies a buried soil in the uppermost part of the Kansan till (fig. 6).

A lower buried soil (216-270 inches) within the Loveland loess in cut 39 indicates that the Loveland is composed of more than one increment. In cut 33 a similar buried soil occurs in the lower 73 inches of the Loveland loess at a depth of 152 inches below the top of the surficial solum in the Loveland. This section occurs below a buried level to slightly rounded summit of the Loveland landscape. On a buried slope 600 feet to the east the lower profile is only 100 inches below the top of the Loveland.

Section F:

Farmdale:	
IA _{1b} 0-15 inches below top of Farmdale loess	Dark grayish brown (10YR 4/2) silt loam; weak medium granular; friable; leached.
IC _b 15-32 inches	Grayish brown (10YR 5/2) to brown (10YR 5/3) silt loam; weak medium granular; friable; leached.
Sangamon soil in Loveland loess:	
IIA _{2b} 32-48 inches	Dark brown (10YR 4/3) to brown (10YR 5/3) silt loam; weak medium subangular blocky; hard when dry, friable when moist; clay skins sparse; leached.
IIIB _{2b} 48-81 inches	Dark brown (7.5YR 4/2) to brown (7.5YR 5/2) silty clay; strong medium subangular blocky; very hard when dry, firm but plastic when moist; clay skins prominent; leached.
IIIB _{3b} 84-100 inches	Brown (10YR 5/3) to yellowish brown (10YR 5/4) heavy silty clay loam; weak coarse angular blocky; hard when dry, firm when moist; clay skins prominent; leached.
Intra-Illinoian soil in Loveland loess:	
IIIA _b 100-125 inches	Dark gray (10YR 4/1) silty clay loam; moderate medium angular blocky; hard when dry, firm but plastic when moist; clay skins prominent; leached.
IIIB _{2b} 125-146 inches	Grayish brown (10YR 5/2) to brown (10YR 5/3) silty clay loam; strong medium subangular blocky; hard when dry, firm when moist; clay skins prominent; leached.
IIIB _{3b} 146-165 inches	Grayish brown (10YR 5/2) to gray (10YR 5/1) silty clay loam; weak coarse angular blocky; hard when dry, firm when moist; clay skins prominent; leached.
IIIC _{2b} 165- inches	Gray (10YR 5/1-6/1) light silty clay loam; massive with vertical cleavage; friable; tubules with clay skins; leached.

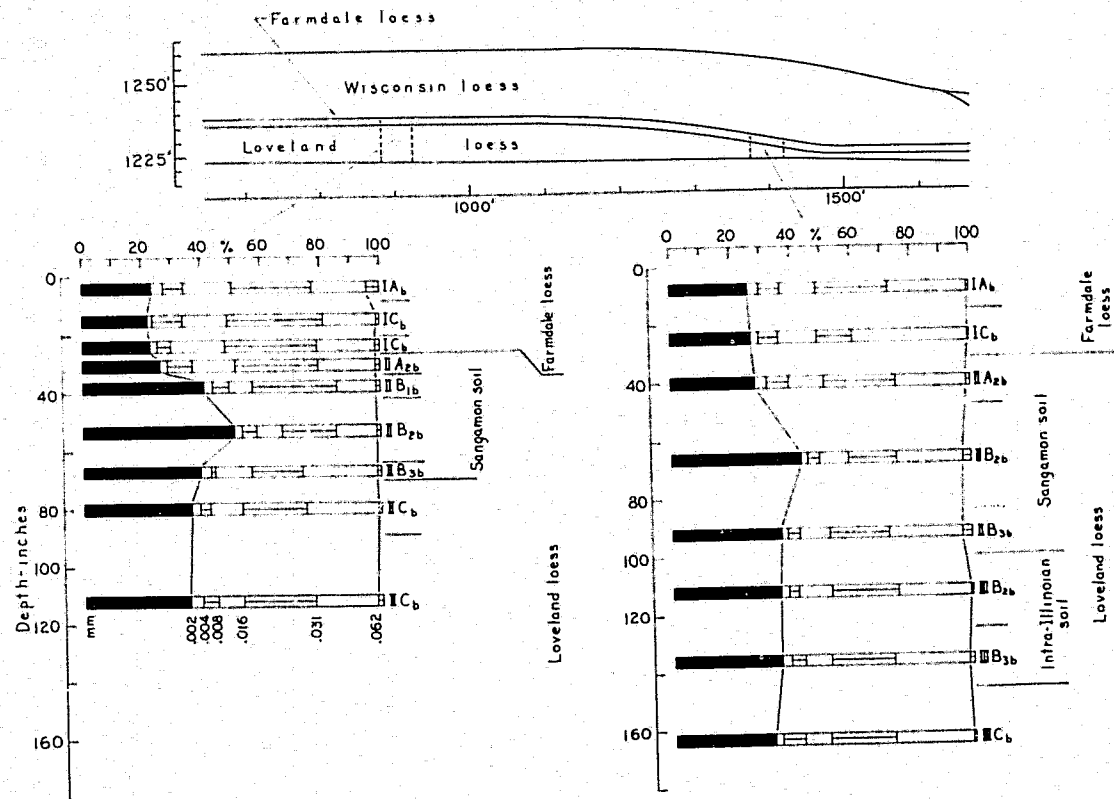

FIGURE 10.—Textures of buried soils in Loveland loess, cut 33.

In the buried slope section of cut 33 there is very little textural change from the IIB₃ horizon to the underlying IIIA-B horizons. Through a depth of 81 inches encompassing all these horizons, the clay content is from 33 to 36 percent (fig. 10). Downward translocation of clay, resulting from the more intensive development in the upper solum and shown by the prominent clay skins throughout all these horizons, masks a textural differentiation. However, a structural differentiation is distinct.

A buried soil occurring within Loveland loess must have been formed during an intra-Illinoian cycle of weathering because the Loveland loess is of known Illinoian age (93, pp. 601-602). The buried soil in the uppermost part of the Loveland loess represents weathering during the Sangamon interglacial stage.

MINERALOGY

Samples of horizons of paleosols in Loveland loess were collected from cuts 25, 26, 31, 39, 45, and 50. In all but cuts 25 and 45 samples were taken from both the upper (Sangamon) and lower (inter-Illinoian) profiles. In addition to the collection from the railroad cuts, samples from a Loveland loess exposure in the Missouri River bluffs near Glenwood, Iowa, were studied. The samples included calcareous loess and a B horizon of a weakly developed soil.

The loess in the section from the bluffs was somewhat coarser than that in cut 50. Composition (table 10) of very fine sand and coarse silt heavy mineral separates indicates that at this site the composition of the Loveland loess was very much like that of Wisconsin loess. The material is very fresh. Even the B horizon sample shows an abundance of easily weathered minerals, such as hornblende and apatite, though there is a slight decrease in these as compared with the calcareous loess. The mica content is high in all size fractions. The clay fraction consists of montmorillonite, illite, and traces of kaolinite.

TABLE 10.—Proportions of nonopaque heavy minerals in a Loveland loess section near Glenwood, Iowa

Mineral	B horizon Sangamon paleosol ¹		Calcareous loess ²	
	100-50 μ ³	50-20 μ	100-50 μ	50-20 μ
	Percent	Percent	Percent	Percent
Epidote.....	24	29	18	25
Tourmaline.....	2	3	4	3
Zircon.....	4	11	1	11
Garnet.....	10	10	5	9
Hornblende.....	45	20	54	23
Titanium minerals.....	10	20	10	18
Apatite.....	3	5	4	9
Miscellaneous.....	2	2	4	2

¹ Mica less than one half hornblende content.

² Mica, especially biotite, equal to one half hornblende content.

³ Size-fraction.

These samples were collected about 25 miles almost due south of Bentley. Presumably the composition of the calcareous Loveland loess would be the same as that in the bluffs directly west of the traverse and can serve as a reference to estimate the degree of weathering which took place in the formation of the Sangamon soils.

Wisconsin Loess

WEATHERING ZONES

The Wisconsin loess is the surficial Pleistocene sediment in all sections along the traverse (pl. I) and is composed of several increments. A basal zone, separated from the overlying loess by a buried A-C profile, is the Farmdale increment (46). Overlying the Farmdale is a sequence of weathering zones some of which are in every cut along the traverse.

The general sequence from the modern surface downward is: (1) Oxidized and leached zone, (2) oxidized and unleached zone, (3) deoxidized and unleached zone, (4) oxidized and unleached zone, and (5) deoxidized and leached zone (pl. I).¹¹ The oxidized and leached loess is a light yellowish brown (10YR 6/4, dry) to yellowish brown (10YR 5/4, moist) massive, friable silt loam. The iron oxide is diffuse throughout the sediment matrix, but prominent light gray (10YR 7/1, dry) to gray (10YR 6/1, moist) mottles are abundant. The loess is leached of carbonate. This zone grades downward into oxidized and unleached loess that is a very pale brown (10YR 7/4, dry) to light yellowish brown (10YR 5/4, moist) massive, friable, calcareous silt loam.

Although iron oxide is diffuse throughout the sediment matrix, prominent light gray mottles are abundant. At the base of this zone a brownish yellow (10YR 6/8, dry) to brown (7.5YR 4/4, moist) iron band abruptly separates the oxidized and unleached loess from an underlying deoxidized and unleached zone. In this lower zone the loess is a light gray (10YR 7/1-7/2, dry) to grayish brown (2.5Y 5/2, moist), massive, friable, calcareous silt loam. Cleavage and fracture surfaces in the sediment show iron oxide staining that is brownish yellow (10YR 6/8, dry) to brown (7.5YR 4/4, moist). Iron oxide also is segregated in tubules (pipestems) and concretions. Usually the zone has many fossils. In the western part of the traverse this zone is the upper faunal zone (fig. 11).

The deoxidized zone is separated sharply from an underlying oxidized and unleached loess that is a pale yellow (2.5Y 7/4, dry) to dark yellowish brown (10YR 4/4, moist), massive, friable, calcareous, fossiliferous silt loam. Iron oxide is diffuse throughout the sediment matrix, but light gray mottles are abundant. Abundant gastropods occur in this zone throughout the traverse. Below this oxidized zone and separated sharply by an iron band is the basal deoxidized and leached loess. This loess is a light gray (10YR 7/1-2.5Y 7/2, dry) to grayish brown (2.5Y 5/2, moist), platy, friable, leached silt loam. Brownish yellow (10YR 6/8, dry) to strong brown (7.5YR 5/6, moist) iron oxide stains are

¹¹ The terminology of weathered zones in Pleistocene deposits in Iowa has a long history (25, p. 162; 26, p. 170) and will be used in this report.

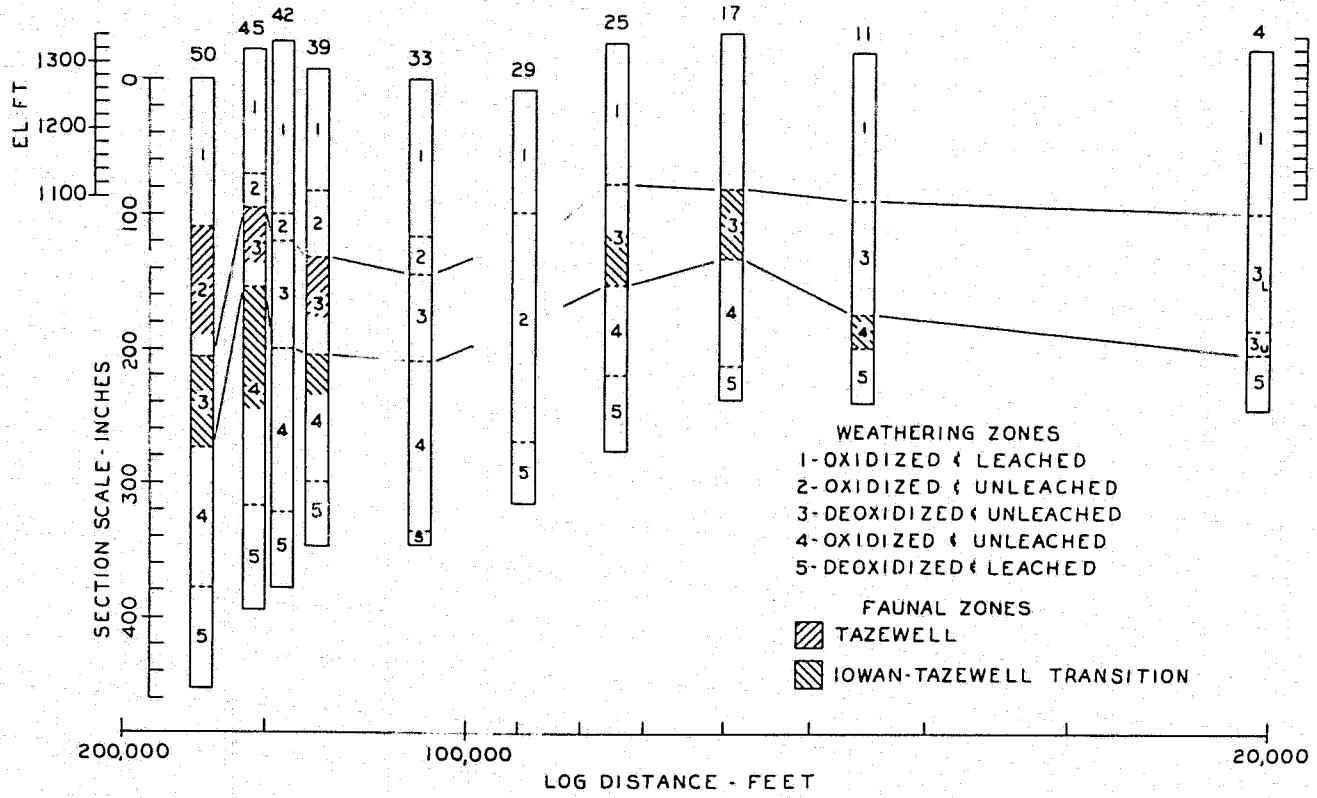

FIGURE 11.—Regional distribution along the traverse at primary and secondary divide sites, cuts 50 to 4, of weathering and faunal zones in Wisconsin loess.

along cleavages and plates. Iron oxide is segregated also in pipe-stems and concretions. The basal deoxidized and leached loess overlies the A horizon of the buried soil in Farmdale loess.

CHARACTERISTICS AND DISTRIBUTION

Some of the properties of Wisconsin loess—thickness, texture, and degree of alteration by weathering—are directly related to topography (47). Several previous investigations in Illinois (63), Iowa (21, 22, 73), and Missouri (59) have shown that the properties, thickness, particle-size distribution, and carbonate content vary exponentially with distance from an assumed source of loess. In these previous investigations, an intensification of the morphological development of soils as well as their physical and chemical characteristics were noted to be related to decreasing thickness of the loess with increasing distance from the assumed source.

An analysis (47, pp. 665-667) of the thickness and texture properties of Wisconsin loess along the traverse shows that there are exponential relationships between thickness-texture and distance from an assumed source only at the crests of primary and secondary divides (fig. 12). The thickness of the Wisconsin loess systematically decreases from 453 inches in cut 50 to 268 inches in cut 4. The correlation coefficient between thickness and distance along the traverse is $r = 0.98$.

Median diameters of oxidized and unleached, the least weathered, Wisconsin loess also systematically decrease from west to east along the traverse. The correlation coefficient is $r = 0.79$ between the median-particle size and distance along the traverse. Other texture data—the systematic decrease of coarser silt and the increase in finer silt and clay with distance—are in accord with the regional relationship.

However, an analysis (47, pp. 667-671) of the thickness and texture data of tertiary divide sites¹² shows a relationship entirely different from that of the regional samples of primary and secondary divide sites (fig. 13). The relationships of thickness of loess to distance along the traverse (fig. 13) are given in table 11. The facts are that the loess is thickest on divide crests and progressively thins on divide flanks both toward and away from the loess source. These facts differ from the generally accepted concept that loess thickness decreases exponentially with distance from the source.

It seems that another factor other than a simple distance relationship controls the thickness distribution of loess. The general parallelism of the thickness curves to the topographic profile of the traverse (fig. 13) suggests that configuration of the surface upon which the loess was deposited influences the thickness distribution of loess. The surface is an older Pleistocene surface and in a macrosense is a rough surface. The thickness of loess relative to a rough surface of deposition may be evaluated by comparing the thickness of the loess at any point on that surface with the

¹² Tertiary divide sites are the level to slightly rounded ridges that occur on the flanks of the primary and secondary divide units.

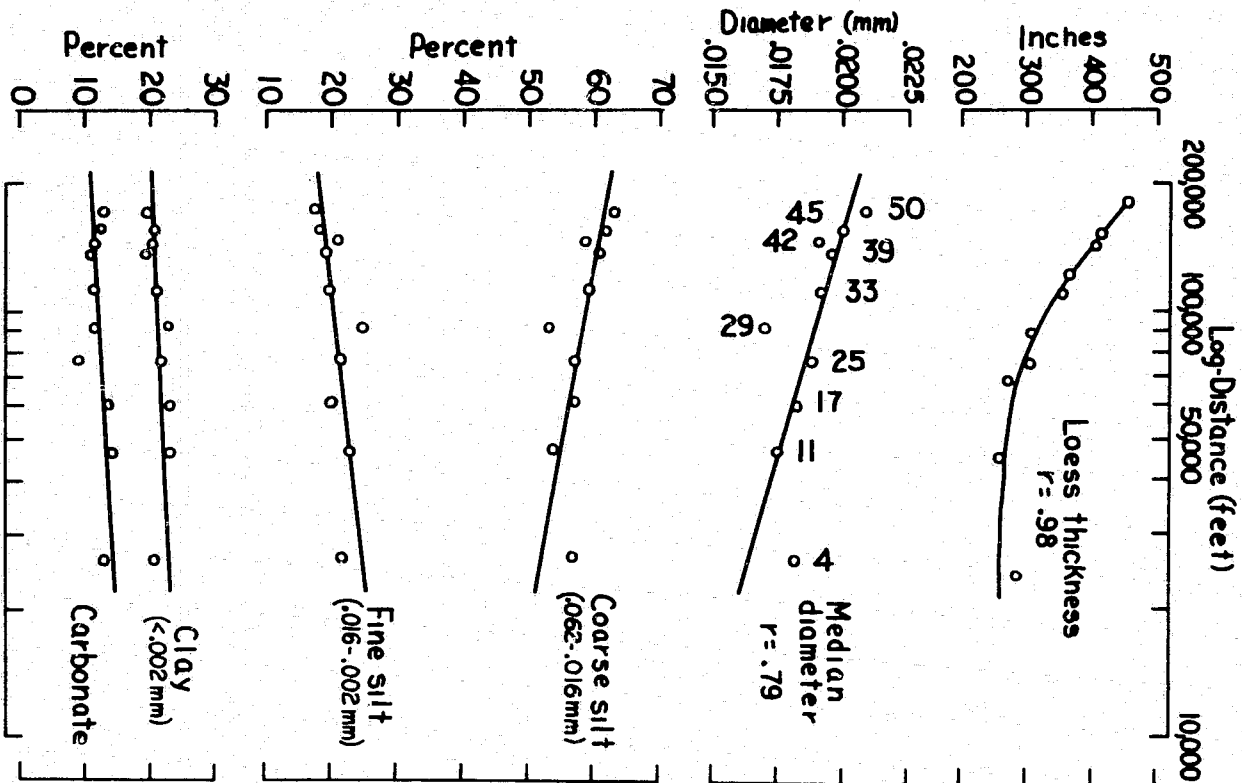
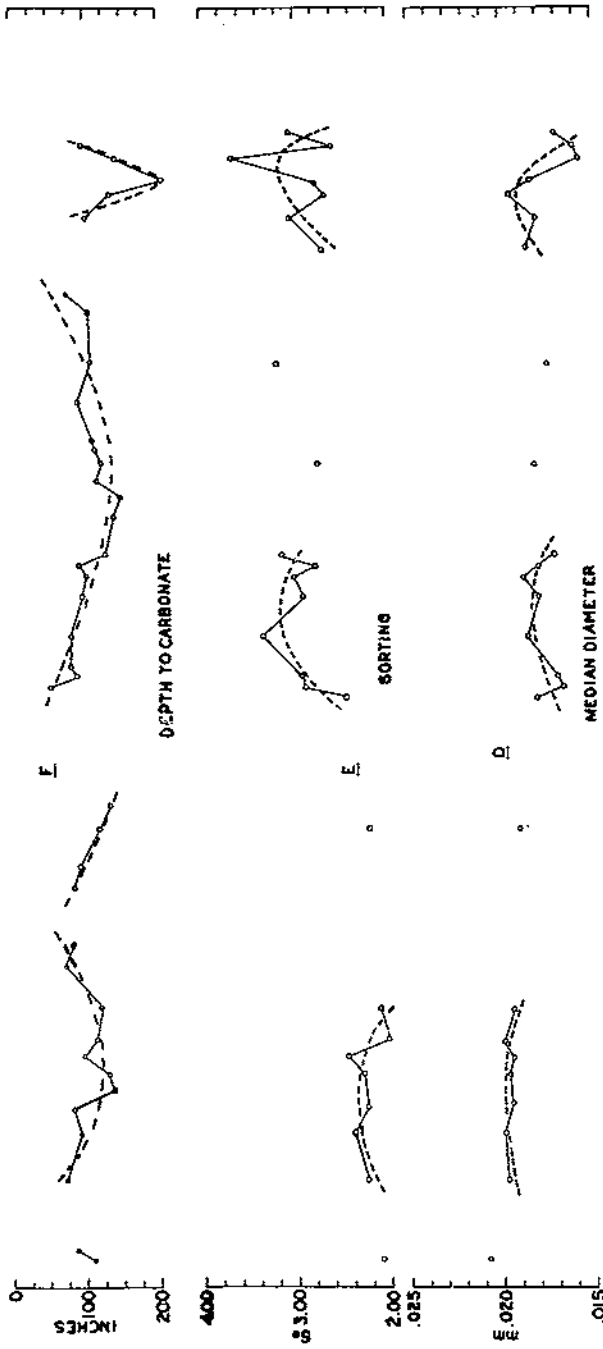

FIGURE 12.—Regional distribution of the thickness, particle-size composition, and carbonate content of Wisconsin loess at primary and secondary divide sites, cuts 50 to 4, along the traverse.



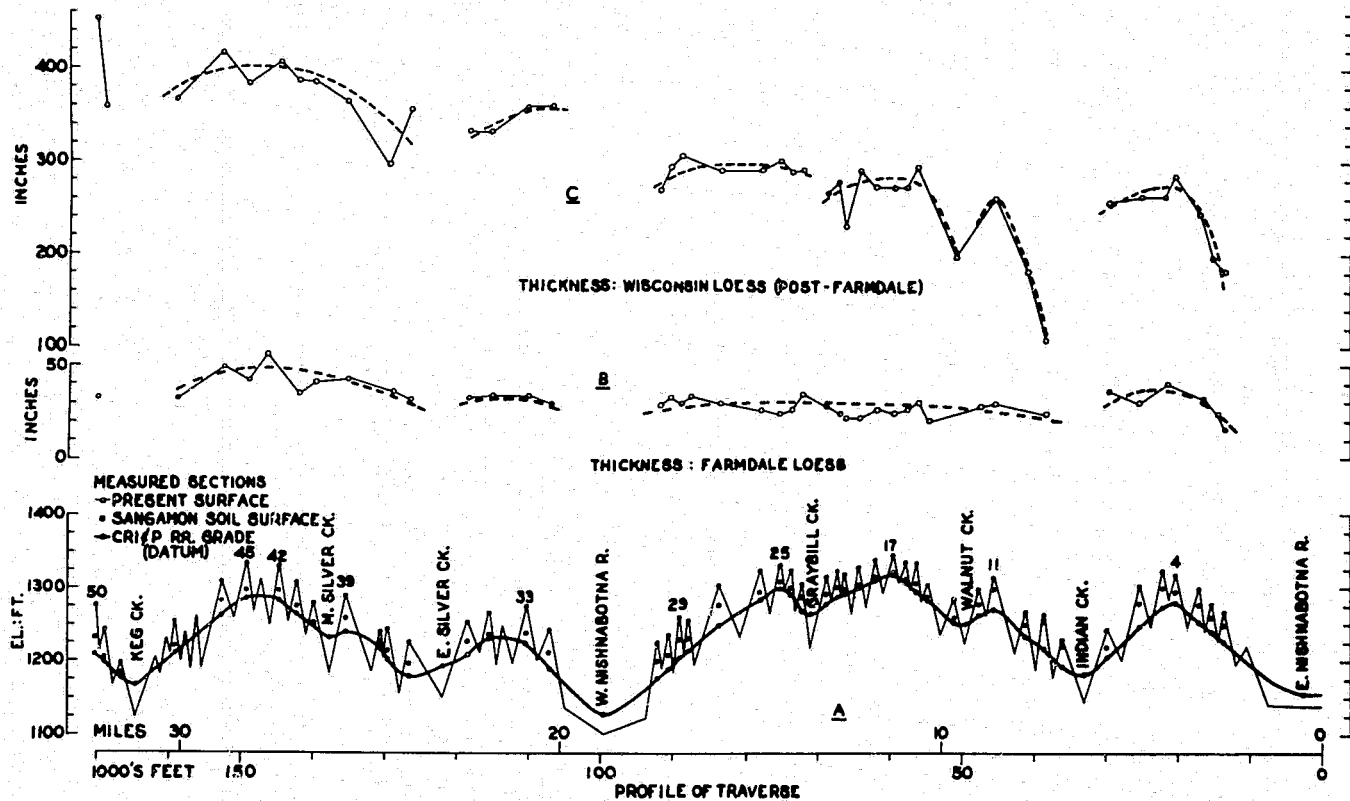

FIGURE 13.—Thickness, texture, and weathering characteristics of Wisconsin loess at primary, secondary, and tertiary divide sites along the traverse.

TABLE 11.—*Relationships of loess thickness across divide units*

Divide unit	Part of traverse	Characteristics
Primary.....	Cuts 46-36	Maximum thickness at crest; progressive thinning on flanks to west and east.
Secondary....	Cuts 35-32	Maximum thickness at crest; progressive thinning on flanks to west and east.
Secondary....	Cuts 31-23	Maximum thickness at crest; progressive thinning on flanks to west and east.
Primary.....	Cuts 22-13	Maximum thickness at crest; progressive thinning on flanks to west and east.
Secondary....	Cuts 11-8	Maximum thickness at crest; progressive thinning on flanks to west and east.
Secondary....	Cuts 7-1	Maximum thickness at crest; progressive thinning on flanks to west and east.

elevation of the surface of deposition at that point. The data tested statistically (fig. 14) show correlation coefficients across divide units of $r = 0.68, 0.77, 0.77, 0.86, 0.87$, indicating that the thickness of loess deposited upon a surface is influenced by the elevation of the surface at the point of deposition.

Thinning of loess on the flanks of divide units is generally uniform both west and east; the mantle is generally symmetrical to the axes of the crests of the pre-Wisconsin surface. Individual cuts in general show the same symmetry of Wisconsin loess mantle on the pre-Wisconsin surface.

An analysis of the median-diameter and sorting-coefficient¹³ data (fig. 13) shows an intercorrelation of the data as well as with the thickness distribution across the divide units. Median diameters are greater at the crests of divides and progressively decrease on both divide flanks which are *toward* and *away* from the loess surface. Previous regional concepts held that mean particle size decreases with distance from the source. The sorting curves indicate that poorer sorting (greater S_o values) occurs at the crests of divide units. Sorting is progressively better (lesser S_o values) down the flanks of divides toward and away from the loess source.

When evaluated in regard to regional relationships these data—thickness distribution and variability in texture across local divides—show that loess sedimentation is complex and not just a simple function of distance from source.

FAUNAL ZONES

Parts of the Wisconsin loess are fossiliferous throughout the segment of the traverse between Bentley and Atlantic, Iowa (fig. 11). Generally west of the West Nishnabotna River, between cuts 33 and 29, are two faunal zones, whereas east of the river one only is common.

¹³The sorting coefficient of a particle-size distribution is a geometric quartile deviation that measures the grouping of the particle sizes about the median.

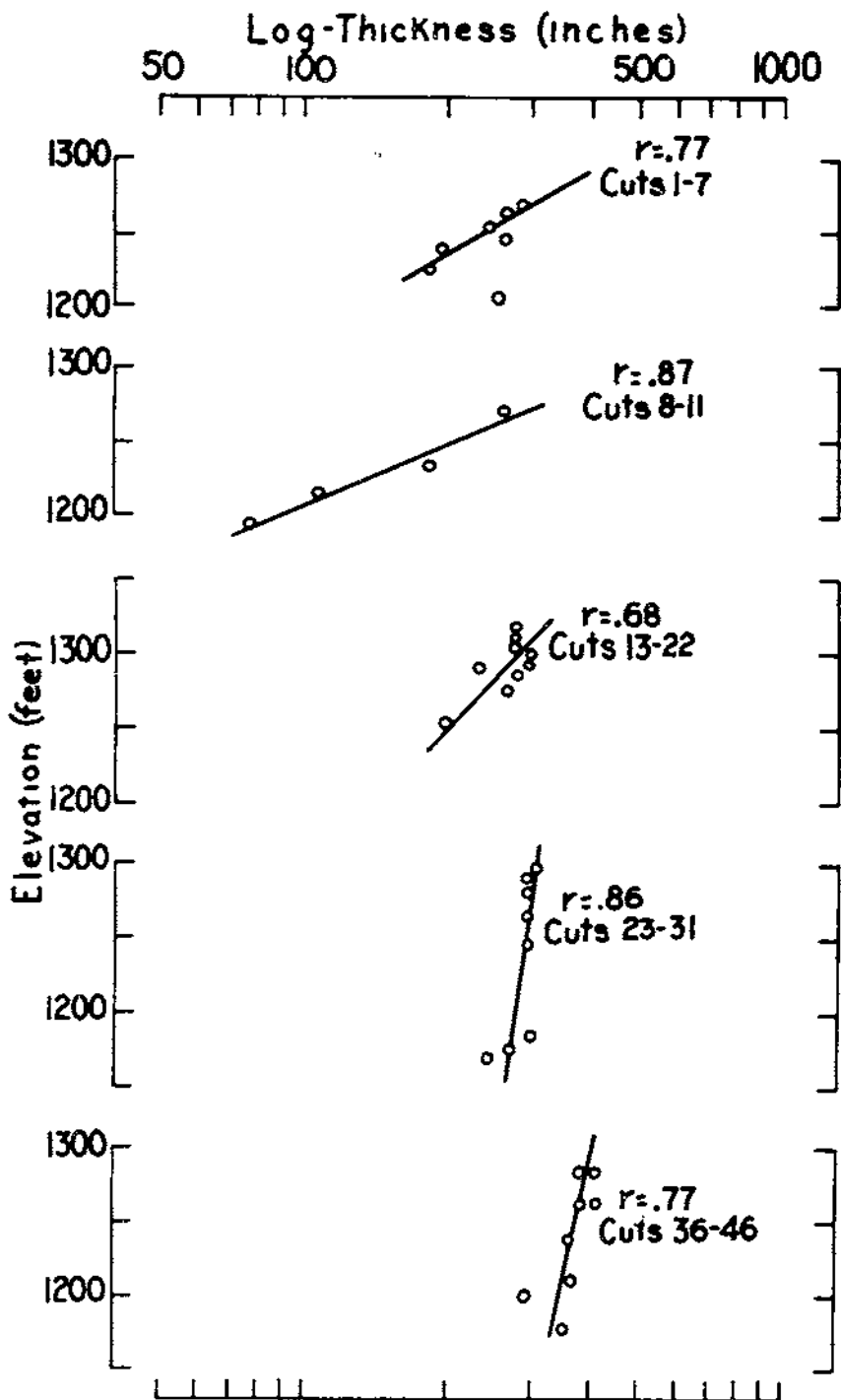

FIGURE 14.—Correlation of the thickness of Wisconsin loess and the elevation of points on the pre-Wisconsin surface at which the loess was deposited.

The upper faunal zone in cuts 50, 45, and 39 contains the species *Succinea ovalis*, *Hendersonia occulta*, *Retinella electrina*, and *Columella alticola* (table 12). Leonard (34, p. 18) considers these species to be diagnostic of the Tazewell zone of the loess of the Wisconsin glacial stage. The lower faunal zone in cuts 50 and 45 contain *Succinea grosvenori*, *Discus cronkhitei*, *Discus shimiki*, and *Vertigo modesta*, that Leonard considers representative of the Iowan-Tazewell transition and Tazewell zones. This latter group of species also characterizes the single faunal zone in cuts 25, 17, and 11.

TABLE 12.—Faunal assemblages in Wisconsin loess along traverse

Species	Cuts and faunal zones ¹							
	50 upper zone	50 lower zone	45 upper zone	45 lower zone	39 upper zone	25	17	11
Tazewell:								
<i>Succinea ovalis</i>	X		X		X			
<i>Hendersonia occulta</i>	X	X	X					
<i>Retinella electrina</i>	X							
<i>Columella alticola</i>			X		X			X
Transition and Tazewell:								
<i>Succinea grosvenori</i>	X	X	X	X	X	X	X	X
<i>Discus cronkhitei</i>	X	X		X		X	X	X
<i>Discus shimiki</i>		X	X	X	X	X		X
<i>Vertigo modesta</i>				X				X
Iowan, Transition, and Tazewell:								
<i>Vallonia gracilicosta</i>	X	X	X					
<i>Pupilla blandi</i>	X				X	X	X	X
<i>Hawaii minuscula</i>				X	X	X		X
<i>Euconulus fulva</i>						X		X
Iowan and Transition:								
<i>Succinea avara</i>	X	X			X	X	X	X
<i>Lymnaea parva</i>						X		

¹ Stratigraphic zonation modified after Leonard (34, p. 18).

If the faunal zonations of Leonard are applicable to the Wisconsin loess of southwestern Iowa, the ages of the loess may be determined. In cut 50 the depth to the base of the upper faunal zone is 190 inches and to the base of the lower faunal zone 274 inches. Total thickness of the post-Farmdale Wisconsin loess is 453 inches. The upper zone represents the Tazewell and the lower the Iowan-Tazewell transition. Thus, the upper 60 percent of the loess in cut 50 must be of Tazewell age. Similarly, other faunal zones along the traverse (fig. 11) indicate that in most sections the upper 60 to 65 percent of the total loess thickness is representative of the Tazewell substage.

AGE

Data from other parts of Iowa (51) have shown that the lower Tazewell is dated by the radiocarbon method at 16,000 to 17,000 years. Stratigraphic and radiocarbon data also have yielded an

immediate post-Tazewell loess date of approximately 14,000 years. Thus, the upper part of the Wisconsin loess along the traverse from Bentley to east of Adair, Iowa, is Tazewell in age and younger than 16,000 to 17,000 years but older than 14,000 years.

The only discernible stratigraphic break in the Wisconsin loess is the buried Regosol that occurs in the uppermost part of the basal Farmdale increment of the Wisconsin. Such a buried soil has been described in cut 11 (sec. D). In cut 33 the buried Farmdale soil is a Humic-Gley which contains abundant wood fragments¹⁴ in the A horizon. The age of this wood has been dated at $24,500 \pm 800$ years by the radiocarbon method (43, W-141).

Radiocarbon analyses and evaluation of stratigraphy permit a reconstruction of the events of the Wisconsin glacial stage represented by the loesses in southwestern Iowa. About 25,000 years ago loess of the Farmdale substage was deposited on a pre-Wisconsin surface. Soil genesis of a Regosolic type followed, characterized only by the leaching of carbonate from the thin Farmdale loess (fig. 13, B) and accumulation of organic matter in the A horizon.

Loess was deposited again in Iowan time.¹⁵ In the beginning it accumulated slowly and carbonates were leached contemporaneously with deposition. This loess, the basal deoxidized and leached zone, may represent the pro-Iowan phase of the Wisconsin loess, that is, the loess accumulated while the Iowan glacier advanced to its maximum limit in Iowa. There is stratigraphic evidence of a cessation of loess deposition during the pro-Iowan phase, or between this phase and the overlying Iowan.

More rapid accumulation of loess followed; carbonates were not leached contemporaneously and unleached zones overlying the basal deoxidized and leached zone resulted. Deposition continued without significant interruption through Tazewell time and ceased 14,000 to 16,000 years ago. The uneroded upland-loess surface in southwestern Iowa dates from that period.

MINERALOGY

The mineralogy of the whole section of Wisconsin loess was not studied since at the time of sampling the interest was in criteria for distinguishing the different deposits. The Farmdale increment was sampled in several of the cuts, and the basal leached zone above the Farmdale in two cuts. Composition of the heavy mineral separates of some representative Farmdale samples, leached zone, and a Marshall silt loam soil profile are shown in tables 13 and 14.

¹⁴ D. W. Bensed, Department of Forestry, Iowa State University, identified the wood as larch (*Larix* sp.).

¹⁵ At the time of conducting the field studies upon which this report is based, the standard Wisconsin glacial-stage section in Iowa was recognized as: Mankato substage, Cary substage, Tazewell substage, Iowan substage, Farmdale substage. After completion of these field studies, evidence based upon radiocarbon dating in other parts of Iowa suggested that the Iowan is older than the Farmdale (54). The suggested revision of the standard section, placement of the Iowan below the Farmdale, already has become embroiled in controversy. Further studies are necessary to resolve the question. In view of the problems involved, it is believed best to retain the standard section in this report pending solution of the stratigraphic classification and correlation of the substages concerned.

TABLE 13.—Proportions of nonopaque heavy minerals of Farmdale loess

Mineral	Sample No. and size-fraction									
	1		11		12		16	17	18	36
	50-100 μ	20-50 μ	50-100 μ	20-50 μ	50-100 μ	20-50 μ	50-100 μ	50-100 μ	50-100 μ	50-100 μ
	Percent	Percent	Percent	Percent	Percent	Percent	Percent	Percent	Percent	Percent
Epidote.....	28	22	25	35	35	35	38	25	27	33
Tourmaline.....	2	2	3	5	3	4	4	2	4	4
Zircon.....	4	20	5	10	5	10	5	5	3	2
Garnet.....	5	6	6	5	5	6	6	10	8	5
Hornblende.....	52	22	55	25	50	28	43	55	50	50
Titanium minerals.....	6	25	5	18	7	20	3	2	3	4
Miscellaneous.....	2	4	1	3	2	6	4	2	3	2

TABLE 14.—Proportions of nonopaque heavy minerals of basal leached Wisconsin loess and Marshall soil

Mineral	Wisconsin loess: sample No. and size-fraction				Marshall soil: ¹ soil horizon, depth, and size-fraction			
	19		34		A, 8-15 inches		C 45-60 inches	
	50- 100 μ	20-50 μ	50- 100 μ	20-50 μ	50- 100 μ	20-50 μ	50- 100 μ	20-50 μ
	Per- cent	Per- cent	Per- cent	Per- cent	Per- cent	Per- cent	Per- cent	Per- cent
Epidote.....	16	38	25	50	25	35	28	40
Tourmaline.....	2	3	2	4	2	4	3	5
Zircon.....	4	7	4	10	4	10	6	12
Garnet.....	12	5	8	8	8	8	8	7
Hornblende.....	60	33	55	8	54	23	48	18
Titanium minerals.....	4	12	4	12	5	15	6	17
Miscellaneous.....	2	2	2	5	3	3	3	5

¹ Mica is relatively abundant throughout; apatite is common.

The Farmdale is easily distinguished from the Sangamon paleosol in Loveland loess by its relative freshness. Amphiboles, pyroxenes, micas, and feldspars are abundant. During the time of development of the paleosol in the Farmdale very little weathering of primary minerals took place.

More study would be needed to determine the significance of the variation in composition of the deoxidized-leached zone above the Farmdale (samples 19 and 34). The release of rather large amounts of free iron oxide to form the concretions and pipestems indicates appreciable weathering. Weathering may have been more intense in localized tongues and pockets and sample 34 may have come from such a place. This sample has a lower feldspar content in the silt than sample 19.

In the Marshall soil the lower weatherable mineral content in the C horizon compared to the A horizon may be due to weathering or to local variation in the material. Ratios between the other minerals are nearly identical. Mica and apatite are common in both horizons.

Heavy mineral composition and mica and feldspar content indicate that Wisconsin loess and modern soils in the region of the traverse are much less weathered than the Loveland loess and soils in it. The sand and coarse silt were not weathered appreciably in any of the samples except sample 34.

Clay fractions in the Wisconsin loess and soils are dominated by montmorillonite; they have moderate amounts of illite and traces of kaolinite. No significant differences among horizons in Farmdale or main Wisconsin loess and soils could be observed by the methods used in this study.

Geomorphology

Related to the complex Pleistocene stratigraphy along the traverse are four major geomorphic surfaces: (1) Yarmouth-Sangamon, (2) Sangamon, (3) Late Sangamon, and (4) Wisconsin complex composed of (a) an Early Wisconsin surface of dissection, (b) an Early Wisconsin terrace along the primary drainages, (c) an Early Wisconsin loess-constructional upland surface, (d) a Late Wisconsin surface of dissection and alluvial fill, and (e) a Recent gully cut and fill surface.

Yarmouth-Sangamon Surface

PALEOSOLS

The Yarmouth-Sangamon surface occurs in cuts D and E at Adair, Iowa (pl. 1). A deep, intensely weathered soil formed on the surface, and in Kansan till (fig. 15). The soil is buried beneath the Wisconsin loess of which the Farmdale is the basal increment. Thus, the buried surface and soil span the stratigraphic range from the Kansan to the basal Wisconsin and must include all or a part of the Yarmouth, Illinoian, and Sangamon. To the westward along the traverse between Atlantic and Bentley, Iowa, this stratigraphic range is represented by: (1) the buried soil in the uppermost part of the Kansan till overlain by Yarmouth clay, (2) the Yarmouth clay and its surficial soil overlain by Loveland loess, and (3) the increments of Loveland loess capped by the intra-Illinoian and Sangamon soils.

The buried soil on the Yarmouth-Sangamon surface at Adair is a "giant" profile in comparison with soils on the modern till landscape in Iowa. The buried profile in cut D shows:

Section G:

Wisconsin loess:

Oxidized and leached
0-128 inches
below modern surface

Yellowish brown (10YR 5/4) silt loam; massive; friable; gray (10YR 6/1) mottles prominent; leached.

Deoxidized and leached
128-152 inches

Light gray (10YR 7/1) to grayish brown (2.5Y 5/2) silt loam; massive; friable; brownish yellow (10YR 6/5) to strong brown (7.5YR 5/6) iron oxide band at top; iron oxide segregated in pipestems and concretions; leached.

Farmdale:

IA_{1b}
152-159 inches

Dark grayish brown (10YR 4/2) light silty clay loam; weak platy; friable; hard yellowish red (5YR 5/6) to dark reddish brown (5YR 3/3) iron oxide concretions abundant; gritty; leached.

Yarmouth-Sangamon soil in Kansan till:

IIA_{3b}
159-177 inches

Dark yellowish brown (10YR 4/4) silty clay loam; weak medium platy to medium granular; hard when dry, firm when moist; gray (10YR 6/1) mottles common; hard yellowish red (2.5Y 5/6) to dark reddish brown (5YR 3/3) iron-oxide concretions very abundant; gritty; leached.

IIIB_{1b}
177-189 inches

Grayish brown (10YR 5/2) heavy silty clay loam; weak medium subangular blocky; hard when dry, firm but plastic when moist; hard yellowish red (5YR 5/6) to dark reddish brown (5YR 3/3) iron-oxide concretions very abundant; yellowish red to dark reddish brown stain on aggregates; clay skins prominent; gritty; leached.

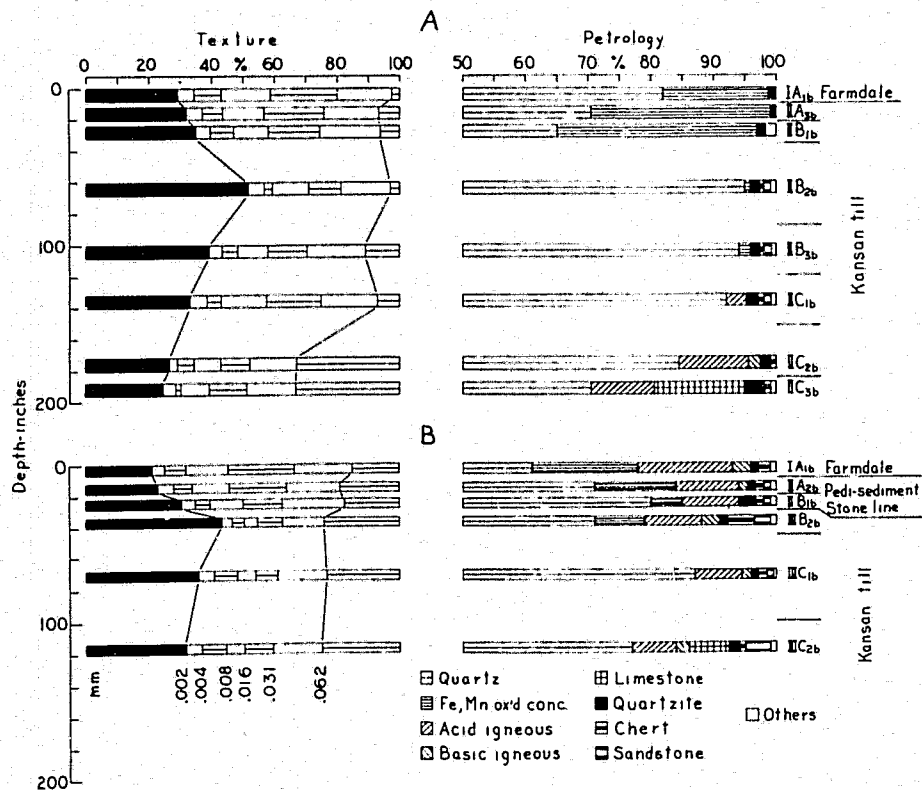

FIGURE 15.—Textural and mineralogical (sand and fine gravel fractions) characteristics of paleosols on the Yarmouth-Sangamon (A) and Late Sangamon (B) surfaces.

IIB _{2ab} 189-242 inches	Gray (10YR 5/1-6/1) heavy silty clay; strong medium subangular blocky; very hard when dry, very firm but plastic when moist; hard yellowish red to dark reddish brown iron-oxide concretions sparse; clay skins on aggregate faces very abundant; gritty; leached.
IIB _{3ab} 242-272 inches	Gray (10YR 5/1-6/1) heavy silty clay loam to silty clay; moderate medium subangular blocky; hard when dry, firm but plastic when moist; hard yellowish red to dark reddish brown iron-oxide concretions very sparse; clay skins prominent; gritty; leached.
IIC _{1ab} 272-306 inches	Light gray (10YR 6/1-7/1) silty clay loam; coarse angular blocky; hard when dry, firm when moist; clay skins sparse; weatherable mineral matter sparse; gritty; leached, deoxidized Kansan till.
IIC _{2b} 306-328 inches	Yellowish brown (10YR 5/6-5/8) clay loam; coarse angular blocky; friable; weatherable mineral matter prominent; gritty to cobbly; leached, deoxidized Kansan till.
IIC _{enb} 328-600 inches	Yellowish brown (10YR 5/8) loam; coarse angular blocky; friable; weatherable mineral matter very prominent; gritty to cobbly; calcareous, oxidized Kansan till; to base of cut.

The buried Yarmouth-Sangamon soil is distinctive in several characteristics. The thickness of the solum approximates 10 feet (fig. 15). The clay of the B₂ horizon amounts to 52 percent, and the B-C horizon clay ratio is 1.5:1.0. None of the till-derived soils on the modern landscape in Iowa have similar ratios although the modern loess-derived Edina soil does (60, pp. 707-708; 73). It is questionable, however, whether a comparison between soils formed in till of heterogeneous texture and in loess of more homogeneous texture is significant.

The Yarmouth-Sangamon soil is intensely weathered. Petrographic study of the sand fractions of the profile (fig. 15) shows only the most resistant mineral particles, such as quartz, quartzite, chert, and sandstone, in the solum. Weatherable material, such as granite and feldspar grains, constitutes less than 4 percent of the fraction of the C₁ horizon. Weatherable mineral particles, granite, diorite, basalt, gabbro, are abundant in the C₂ horizon 12½ feet below the top of the solum, the former landscape surface. Readily weatherable material—limestone and dolomite particles—occurs in the C_{en} horizon, the upper limit of which is 14 feet below the old landscape surface.

The buried soil contains hard yellowish red to dark reddish brown iron oxide concretions in the upper part of the solum: IA₁₀-Farmdale, 14 percent; IIA_{3b}, 28 percent; IIB_{1b}, 32 percent; IIB_{2b}, 6 percent; IIB_{3b}, 2 percent. Maximum concentration of the iron oxide above the impermeable IIB_{2b} horizon suggests that the iron oxide is not related genetically to the morphological development of the buried solum but is an addition of material in the upper part subsequent to horizon development. The presence of hydrous to hydrated iron oxide may be the result of Sangamon weathering that caused the yellowish red to dark reddish brown colors that are characteristic of the Sangamon soils in Loveland loess. Or the iron oxide may result from material brought down and precipitated from subsurface water percolating down through the overlying Wisconsin loess. In either case the more impermeable IIB_{2b} horizon has acted as a barrier above which the iron oxide has been precipitated.

Kay (24), who originally defined gumbotil, reported the occurrence of gumbotil in the section at Adair (25, p. 129). The horizons of the buried soil, IIB_{1gh} to IIB_{3gh}, at depths of 177 to 272 inches, are the gumbotil of Kay. Although the gumbotil was recognized as the most weathered phase of till, Kay did not consider gumbotil to be part of a buried soil but rather something distinct from soil. For example, Kay states: "The Aftonian interglacial stage is represented in Iowa by widespread *gumbotil*, peat, mucks, *old soils*, weathered sands and gravels . . ." (25, p. 182), and "On the *gumbotil* in none of these exposures is there a soil to testify that the full original thickness is present. A well exposed section showing the *gumbotil* to be eleven feet thick with soil above it . . ." (25, p. 260). [Italics ours.] Scholtes et al. (56), pointed out that the gumbotil is the B horizon of a paleo-Planosol or Wiesenboden (Humic-Gley). Simonson (60, pp. 711-716) has reaffirmed, but with more detailed evidence, the fact that gumbotil is the B₁ horizon of a Planosol or Humic-Gley formed from glacial drift during an interglacial age.

Although Kay (25, p. 260) and Simonson (60, pp. 711-716) consider the gumbotil to represent the Yarmouth interglacial stage, the stratigraphic range of weathering of this buried soil in southwestern Iowa encompasses the Yarmouth, Illinoian, and Sangamon interglacial ages.

DISTRIBUTION

The Yarmouth-Sangamon surface at Adair occupies the divide topographic position between Turkey Creek to the west and Middle River to the east (pl. I, D). Down the west flank (C, B, A) and down the east flank (F, G, H), the gumbotil does not occur. Instead, the Kansan till is truncated by an erosion surface which is indicated by a stone line below variable thicknesses of translocated till-like sediment. A shallow buried soil, that contains weatherable mineral matter throughout the solum, is formed in the translocated sediment, stone line, and uppermost part of the Kansan till (fig. 15). This buried soil in all flank-position cuts is overlain by the Wisconsin loess with its basal Farmdale increment. Thus, the buried surface on the crest and on the flanks of the Turkey Creek-Adair-Middle River traverse is pre-Farmdale. The crest unit at Adair is Yarmouth-Sangamon, but the lower stratigraphic limit of the flanking bevels cannot be fixed with certainty by the evidence available along this segment of the major traverse. Both the Yarmouth-Sangamon surface and the flanking bevels are dissected by an erosion surface that is younger than the flanking bevels as well as by a surface that is younger than the subage of the youngest Wisconsin loess.

Sangamon Surface

PALEOSOLS

The Loveland loess is of known Illinoian age (33, pp. 601-602). A paleosol in the uppermost part of the Loveland loess is overlain by the Farmdale loess of known earliest Wisconsin age (33, pp.

TABLE 15.—Proportions of nonopaque heavy minerals of paleosols in Loveland loess

Mineral	Cut 50							
	Sample 37		Sample 38		Sample 39		Sample 40	
	50- 100 μ	20-50 μ	50- 100 μ	20-50 μ	50- 100 μ	20-50 μ	50- 100 μ	20-50 μ
	Per- cent	Per- cent	Per- cent	Per- cent	Per- cent	Per- cent	Per- cent	Per- cent
Epidote.....	45	33	38	40	38	38	37	35
Tourmaline.....	7	6	5	4	5	6	8	7
Zircon.....	4	9	14	18	7	16	4	15
Garnet.....	9	8	10	7	8	8	6	12
Hornblende.....	23	28	10	8	30	10	32	10
Titanium minerals.....	10	14	16	20	10	21	7	16
Miscellaneous.....	3	3	5	3	2	1	6	4

Mineral	Cut 50		Cut 45				Cut 39	
	Sample 41		Sample 54		Sample 55		Sample 28	
	50- 100 μ	20-50 μ	50- 100 μ	20-50 μ	50- 100 μ	20-50 μ	50- 100 μ	20-50 μ
	Per- cent	Per- cent	Per- cent	Per- cent	Per- cent	Per- cent	Per- cent	Per- cent
Epidote.....	38	35	40	36	40	34	51	40
Tourmaline.....	4	6	5	8	4	5	5	5
Zircon.....	8	18	8	16	7	15	7	15
Garnet.....	10	10	6	8	6	4	9	6
Hornblende.....	35	8	28	2	32	16	13	8
Titanium minerals.....	5	20	7	22	5	20	8	20
Miscellaneous.....	2	5	6	8	5	6	7	5

Mineral	Cut 39							
	Sample 29		Sample 30		Sample 31		Sample 32	
	50- 100 μ	20-50 μ	50- 100 μ	20-50 μ	50- 100 μ	20-50 μ	50- 100 μ	20-50 μ
	Per- cent	Per- cent	Per- cent	Per- cent	Per- cent	Per- cent	Per- cent	Per- cent
Epidote.....	45	38	40	35	40	32	50	40
Tourmaline.....	5	9	5	3	3	3	5	6
Zircon.....	7	16	8	20	4	20	4	20
Garnet.....	11	3	12	7	6	10	12	12
Hornblende.....	24	10	25	3	35	5	10	1
Titanium minerals.....	6	24	5	25	8	20	12	20
Miscellaneous.....	2	3	5	5	4	8	4	6

TABLE 15.—Proportions of nonopaque heavy minerals of paleosols in Loveland loess
—Continued

Mineral	Cut 39		Cut 33					
	Sample 33		Sample 27		Sample 26		Sample 30	
	50- 100 μ	20-50 μ	50- 100 μ	20-50 μ	50- 100 μ	20-50 μ	50- 100 μ	20-50 μ
	Per- cent	Per- cent	Per- cent	Per- cent	Per- cent	Per- cent	Per- cent	Per- cent
Epidote.....	40	38	41	35	44	42	37	40
Tourmaline.....	3	4	3	5	4	5	4	6
Zircon.....	6	17	6	12	6	18	10	20
Garnet.....	12	6	12	8	10	10	16	9
Hornblende.....	30	4	27	10	28	3	17	5
Titanium minerals.....	7	25	8	15	7	16	13	15
Miscellaneous.....	2	6	5	5	2	6	3	5

Mineral	Cut 33						Cut 26	
	Sample 31		Sample 32		Sample 33		Sample 10	
	50- 100 μ	20-50 μ	50- 100 μ	20-50 μ	50- 100 μ	20-50 μ	50- 100 μ	20-50 μ
	Per- cent	Per- cent	Per- cent	Per- cent	Per- cent	Per- cent	Per- cent	Per- cent
Epidote.....	40	36	37	45	40	39	27	30
Tourmaline.....	5	8	4	5	6	7	3	5
Zircon.....	10	12	8	15	10	10	5	20
Garnet.....	15	5	19	15	12	11	4	3
Hornblende.....	25	12	16	5	15	5	48	20
Titanium minerals.....	5	22	13	20	5	22	4	23
Miscellaneous.....		6	3	5	10	7	1	1

Mineral	Cut 26		Cut 25			
	Sample 9		Sample 56		Sample 53	
	50- 100 μ	20-50 μ	50- 100 μ	20-50 μ	50- 100 μ	20-50 μ
	Per- cent	Per- cent	Per- cent	Per- cent	Per- cent	Per- cent
Epidote.....	50	40	45	42	47	45
Tourmaline.....	8	5	6	5	7	5
Zircon.....	5	16	6	15	5	15
Garnet.....	8	6	7	8	7	10
Hornblende.....	24	4	25	2	23	1
Titanium minerals.....	5	28	6	22	7	20
Miscellaneous.....	1	1	5	4	6	5

602-603). Therefore, such a buried soil must represent weathering during the Sangamon interglacial age.

The buried soils on the Sangamon surface increase in intensity of development in an easterly direction along the traverse (fig. 16). The regional qualifications of topographic positions pointed

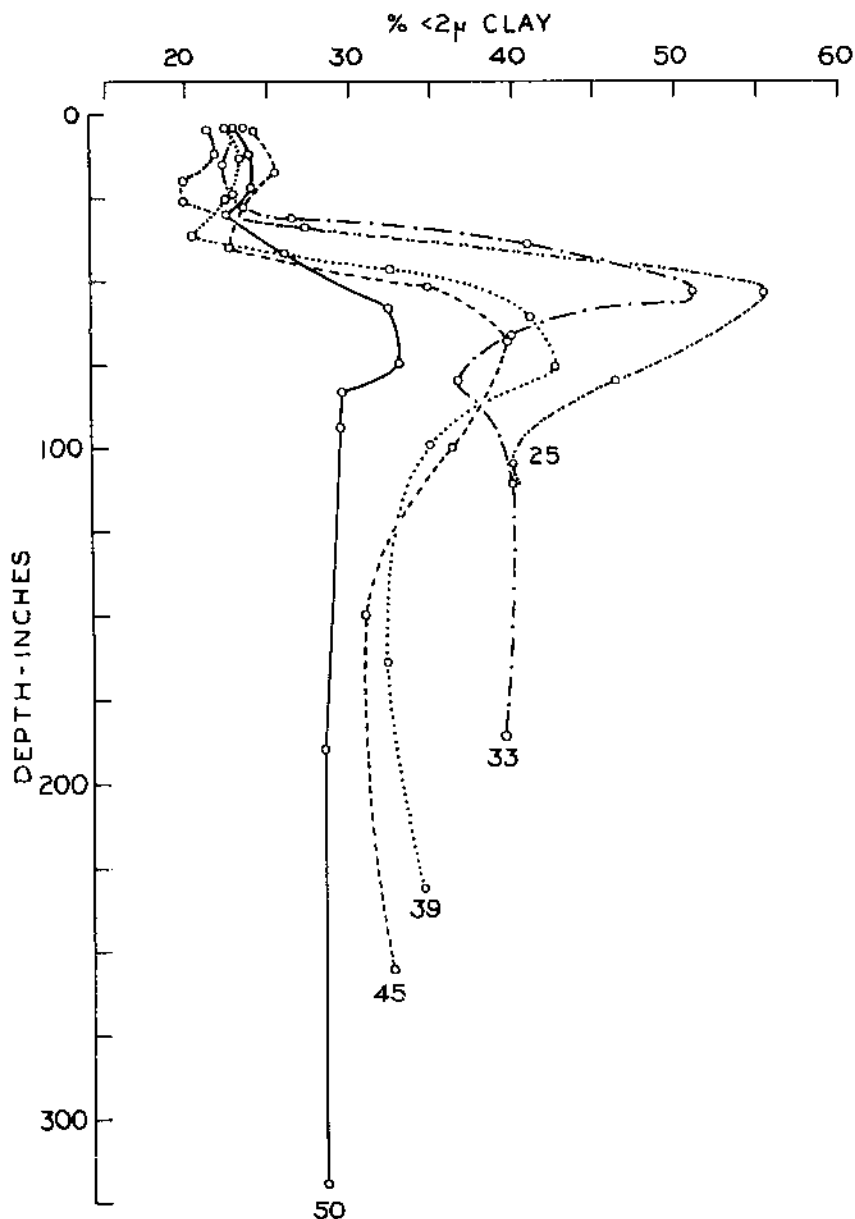

FIGURE 16.—Comparison of clay content of paleosols of Sangamon surface in Loveland loess. Sample sites are primary and secondary divides, cuts 60 to 25.

out by Ruhe (47, pp. 665-667) for studies of Wisconsin loess have been applied to the soils of the Sangamon surface. The sites are restricted to primary and secondary divides along the traverse.

The amount of clay accumulated in the B_2 horizons increases progressively from west to east along the traverse: cut 50, 32 percent; cut 45, 39 percent; cut 39, 42 percent; cut 33, 51 percent; and cut 25, 55 percent. A progressive increase in clay content of the C horizon in the Loveland loess from 28 percent at cut 50 to 39 percent at cut 33 (fig. 16) corresponds to the progressive increase in intensity of weathering of the overlying sola. Such variation of the textures of the C horizons may be mainly the result of deep weathering rather than particle-size fractionation during loess deposition. Clay skins occur along former root tubules deep within the C horizons.

The amounts of clay accumulation in the B_2 horizons of the Sangamon soil in Loveland loess are related exponentially to dis-

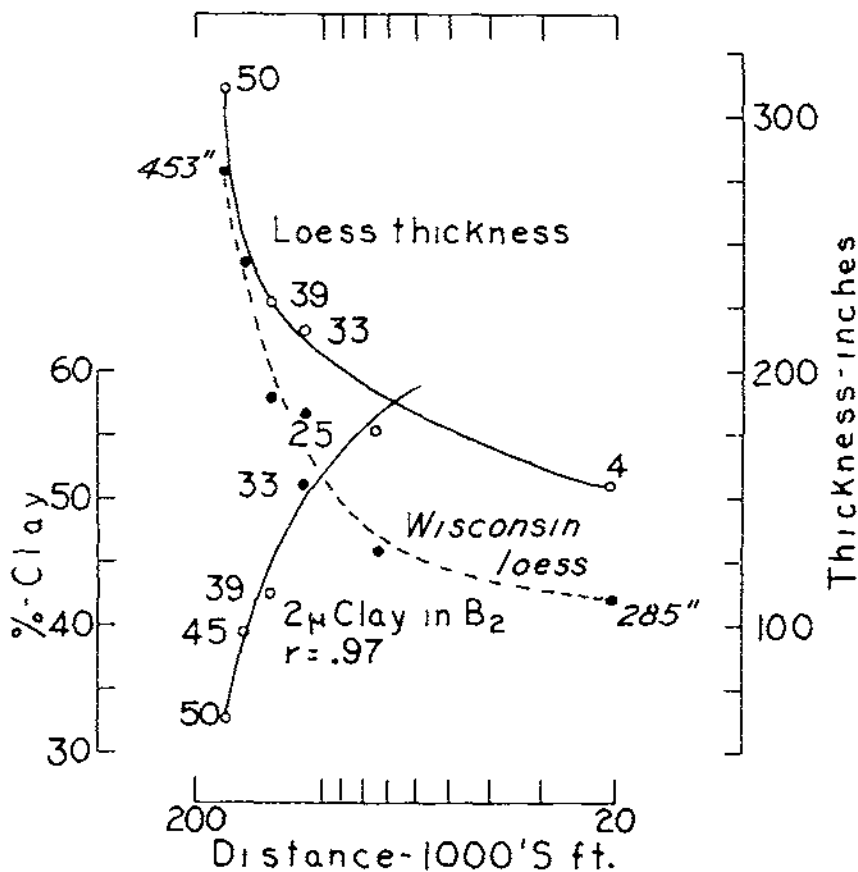

FIGURE 17.—Relationship of thickness of Loveland loess and amount of clay in B horizons of Sangamon paleosols to distance along the traverse. Sample sites are primary and secondary divides, cuts 50 to 4. Thickness of Wisconsin loess at same sites plotted for comparison.

tance along the traverse (fig. 17). An excellent correlation coefficient of $r = 0.97$ exists. The curve of maximum clay accumulation approximates a reciprocal of the curve of thickness of Loveland loess to distance along the traverse. Such exponential relationships previously have been noted in the modern soils developed in Wisconsin loess in southwestern Iowa (21, pp. 428-429).

Composition of heavy mineral separates of samples of buried soils in Loveland loess are shown in table 15. In cuts 50, 39, and 33 samples 40, 41, 31, 32, 33, 24, 23, and 22 were collected from the lower profile representing an intra-Illinoian cessation of loess deposition. The other samples were from the Sangamon soils in the upper part of the Loveland section.

Throughout the traverse the Loveland loess has been rather intensively weathered as indicated by the amphibole content of the heavy mineral separates. The low hornblende content in the coarse silt as compared with that in the very fine sand is probably a significant indicator of weathering. The absence of any horizons with a particularly high hornblende content, even in deep horizons in cut 50, suggests that the loess may have originally had a low amphibole content. However, comparison with the calcareous Loveland loess from the Glenwood section shows that the original deposit was very high in these weatherable minerals. The coarse silt in the calcareous Loveland has a hornblende content of about 25 percent; the highest hornblende content in this fraction in the traverse is 16 percent in the C horizon of the Sangamon soil in cut 45. The higher percentages in samples 37 and 10 are believed to be the result of mixing of Farmdale material.

The rather erratic ratios between various resistant minerals such as zircon-tourmaline and zircon-garnet indicate that significance of small difference is questionable. Some of the variation may be due to variations in the deposit itself and some may be due to sampling, separation, and counting procedure. Therefore it is possible only to indicate certain general trends.

There is some evidence of an increase in weathering eastward along the traverse. The hornblende content of the coarse silt is higher in the samples from cut 50 than in those from cut 25. However, there are high and low values in all sections; the hornblende contents through cut 39 are not consistently different from those in cut 33. The samples representing the intra-Illinoian lower profile appear to be weathered as much as those from the Sangamon profile.

Feldspar content ranges from 15 to 20 percent in the very fine sand down to 1 to 2 percent in the fine silt. Proportions are lower than in Wisconsin loess. Variations are irregular and do not seem to be associated with position in the profile or in the traverse, though the samples from cut 50 have a slightly higher feldspar content than the others.

The mica content of the sands and silts from the railroad cuts is much lower than that of the samples from the Glenwood section and of Wisconsin loess. Weathering of biotite and muscovite

may account for part of the increase in clay. The mica content of cut 50 samples is slightly higher than the others.

The decrease in fine silt from one end of the traverse to the other may in part be due to weathering, as indicated by the slight changes in amphibole, feldspar, and mica. Though some weathering difference is suggested, the amount of difference would not account for the rather large increase in clay. If the amphibole and mica were to weather out completely the resulting loss would be only 1 or 2 percent of the total material.

Clay fractions of the Loveland materials consist mainly of montmorillonite; they have moderate amounts of illite and 10 percent or less of kaolinite. There were no differences among the samples discernible by the methods used, except a slight variation in kaolin content. The mineralogy of the clay fractions is essentially the same as that of the tills and the Wisconsin loess and soils. The composition of the clay is further indication that, despite their color, Sangamon paleosols are more closely related to Gray-Brown Podzolic soils than to the Red-Yellow Podzolic soils. The clay fractions of the latter commonly are dominated by kaolin minerals and in many of the well-developed Gray-Brown Podzolic soils in humid regions the clay fractions are dominated by vermiculite and illite and have smaller amounts of montmorillonite.

Observations of thin sections show that the loess contains an abundance of aggregates of clay in the fine sand and silt size range. Some of these are balls, others are platy or prismatic. The Loveland loess may have contained large amounts of clay in such forms at the time of deposition. Many of these aggregates were probably cemented by lime and remained as ghosts when the lime leached out. It is possible that a part of the explanation for the great increase in clay with distance in the Loveland as compared with the Wisconsin is the presence in the source of abundant clay aggregates of sand and silt size.

This in turn would promote the greater development of the soils shown by the large increase in clay percentage in the B within a relatively short distance. With more clay in the original material more clay would be available to move from A horizon to B horizon. The higher clay content would restrict water movement and development of large pore space and restrict movement of clay to a rather thin layer resulting in high clay content in a relatively shallow profile.

PALEOSOLS AND MODERN SOILS

Distinct differences are noted when the morphologies of the Sangamon soils in Loveland loess are compared with the morphologies of modern soils in Wisconsin loess (fig. 18). A common point for comparison is the juxtaposition of the Marshall soil and the cut 50 Sangamon soil on the thickness curves. Both soils formed in comparable thicknesses of loess: Marshall, 338 inches of Wisconsin loess; cut 50, 313 inches of Loveland loess. Both soils have the same amount of clay in their B₂ horizons, 33 percent.

However, the modern soils and Sangamon soils are totally dissimilar along the traverse toward end members of comparable

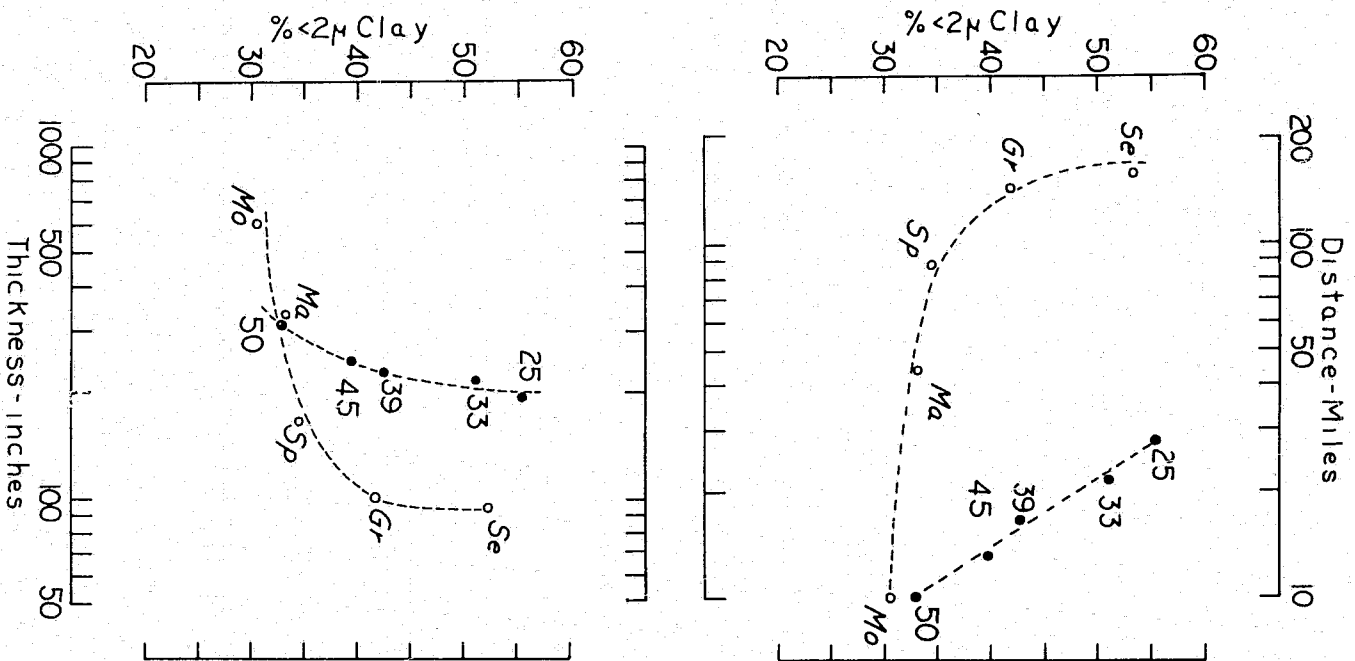

FIGURE 18.—Comparison of thickness-clay accumulation in B horizon-distance relationships of Sangamon paleosols in Loveland loess and modern soils in Wisconsin loess. Sangamon paleosols: 50-25; modern soils: Mo-Monona, Ma-Marshall, Sp-Sharpsburg, Gr-Grundy, Se-Seymour.

amounts of clay in the B₂ horizons. In the modern soils a distance of 113 miles and a decrease of thickness of Wisconsin loess of 243 inches, from 338 to 95 inches, are required for development of the Seymour silty clay loam with 53 percent clay in the B₂ horizon. In the Sangamon soils a distance of only 18 miles and a decrease of Loveland loess thickness of only 121 inches, from 313 inches to 192 inches, are required for development of 55 percent clay in the B₂ horizon of the Sangamon soil in cut 25.

A second comparison emphasizes the distinction of one loess thickness-clay accumulation-distance relationship from the other (table 16). Along the traverse of 18 miles (cuts 50 to 25) the modern soils that formed in the Wisconsin loess, Monona silt loam and Marshall silt loam, show an increase of only 3 percent clay in the B₂ horizons with a decrease in loess thickness of 148 inches. The Sangamon soils formed in Loveland loess at the same sample sites show an increase of 23 percent clay in the B₂ horizons with a decrease of only 121 inches in loess thickness. In each case the decrease in loess thickness is approximately one third, 148 inches in Wisconsin loess and 121 inches in Loveland loess.

TABLE 16.—Comparison of loess thickness-distance along traverse and amount of clay (< 2 μ) in B₂ horizons of modern soils in Wisconsin loess and Sangamon paleosols in Loveland loess

Cut	Loess thickness		Distance along traverse	Clay in B ₂ horizon	
	Wisconsin	Loveland		Wisconsin	Loveland
	<i>Inches</i>	<i>Inches</i>	<i>Miles</i>	<i>Percent</i>	<i>Percent</i>
50-----	453	313	0.0	¹ 30.4	² 32.8
45-----	418	248	3.3	-----	----- ³ 39.5
39-----	365	227	6.6	-----	-----42.5
33-----	357	215	11.3	-----	-----51.0
25-----	305	192	17.9	² 33.0	55.3

¹ Monona silt loam.

² Sangamon buried soils.

³ Marshall silt loam.

There are excellent correlations between the data of loess thickness and distance along the traverse with clay content in the B horizons for the soils formed on Wisconsin and Loveland loess. But there is a great discrepancy when the two sets of data are compared. Thus, it seems apparent that variations in loess thickness with distance along a traverse are not solely responsible for the increased intensity of development of soils.

DISTRIBUTION

The distribution pattern of the Loveland loess with its surficial Sangamon soil along the traverse shows not only the geomorphic expression of the pre-Loveland landscape but also the geomorphic expressions of younger landscapes. The complex distribution pattern relative to positions on divide units and elevations on the

divide units (table 9) shows that the Loveland loess blanketed an erosional landscape on which ancestral streams of the present primary and secondary drainages were emplaced (pl. I).

For example, Loveland loess occurs in cut 49 on the east flank of the primary divide (50) and on the west flank (45) of the primary divide unit (40-46) that slope to the present valley of Keg Creek. The loess occurs down the east flank (42-41) of the primary divide unit (44-40) and continues across Middle Silver Creek and across secondary divide unit (39-36) and down its east flank (37-36) to East Silver Creek. Middle Silver Creek may be a post-Sangamon drainage emplacement. The Loveland loess rises up the west flank of a secondary divide unit (35-32), crosses the crest (33), and descends part way down the east flank to the West Nishnabotna River. Such distribution shows that ancestral Keg Creek, East Silver Creek, and West Nishnabotna River were emplaced prior to Loveland (Illinoian)-loess deposition. Further, the primary divides at cuts 50 and 44 as well as the secondary divide at cut 33 were formed prior to Loveland loess deposition. The emplacement of Middle Silver Creek and the establishment of the secondary divide cut 39 may be post-Sangamon in age.

Similar geomorphic relationships are discernible from the West to the East Nishnabotna Rivers (pl. I). However, the occurrence of Yarmouth clay as well as of Loveland loess helps to establish the geomorphic datum. The general accordance of elevations of the Yarmouth clay has been shown from cuts 3 to 27 (table 7). The lacustrine nature of the bed suggests that the clay lay on a continuous level upland and probably had greater geographic distribution than shown by the remnants of the beds from cuts 3 to 27.

Loveland loess on flanks and crests of both primary and secondary divide units in the area of the Yarmouth clay shows that the primary and secondary drainages, West Nishnabotna River, Walnut Creek, Indian Creek, and East Nishnabotna River, were emplaced after deposition of Yarmouth clay but before the deposition of Loveland loess. The primary and secondary divides (cuts 17, 11, 4) were established at this time. The age can be established as Late Yarmouth, that is, subsequent to Yarmouth soil formation on Kansan till (fig. 6) and Yarmouth lake clay deposition, probably contemporaneous with soil formation on Yarmouth clay, prior to deposition of Loveland (Illinoian) loess.

The emplacement of Graybill Creek and establishment of the secondary divide (pl. I, cut 25) may be post-Sangamon.

Thus, along the traverse the major geomorphic expression that resulted from the establishment of primary and secondary drainages and primary and secondary divides date from Late Yarmouth time. Loveland loess was deposited on such a landscape. Its surficial Sangamon soil remained as a stable landscape element on the crests and upper flanks of previously established divide units.

VEGETATION

Most of the soils of the Sangamon surface in Loveland loess have some morphological and textural characteristics similar to

those of modern Gray-Brown Podzolic soils (9, p. 973). They are more strongly weathered than the modern soils at the same positions in the traverse but still retain fairly large proportions of feldspars and amphiboles.

The Sangamon soils differ in that they have stronger chromas and redder hues in the B₁ horizons than their modern analogues. The stronger chromas and redder hues of the Sangamon subsoil suggest that the soils may be intergrades toward the analogous modern Red-Yellow Podzolic soils (71, p. 120). The color of the Sangamon soil has been discussed at some length in the literature (72, pp. 12-16; 35, pp. 304-305; 17, pp. 19-25; 60, pp. 716-723). The general opinion regarding the reddish colors in Sangamon soils is that they may reflect higher temperatures or longer periods of weathering or both.

These colors have suggested that the soils are related to the Red-Yellow Podzolic soils. Free iron oxide content (table 17) is considerably below that common in Red-Yellow Podzolic soils. Samples 45 and 47, the highest shown, are B and C horizons of a Marshall soil. Free iron oxides in Red-Yellow Podzolic soils generally are 5 percent or higher. These values are in the range found in the B₂ horizons of some Gray Wooded, Gray-Brown Podzolic, and Podzol soils but below the values found in Red-Yellow Podzolic and Reddish Prairie soils.

TABLE 17.—Free iron oxide in Sangamon paleosols¹

Sample	Description	Fe ₂ O ₃
		<i>Percent</i>
38	B horizon, cut 50.....	1.78
54	B horizon, cut 45.....	1.62
55	C horizon, cut 45.....	1.16
29	B horizon, cut 39.....	1.49
9	B horizon, cut 26.....	1.35
56	B horizon, cut 25.....	1.53
53	C horizon, cut 25.....	0.99
45	B horizon, Marshall.....	2.00
47	C horizon, Marshall.....	1.79

¹ Determinations by R. C. Vanden Heuvel by the method of Aguilera and Jackson, Soil Sci. Soc. Amer. Proc., 17: 359-364, 1953.

Examination of the soils in their natural structural condition shows that the reddish coloration is often on the surfaces of the peds, the interiors being yellowish brown or grayish brown color. Hence, the total volume of red pigmentation may be small but still gives a distinct red cast to a deposit seen in an exposure. Materials from cuts at the western end of the traverse where the loess is coarser and somewhat better drained have a slightly higher free Fe₂O₃ content than those farther east.

B horizons have slightly higher free Fe₂O₃ content than C horizons. This may indicate the podzolic character of these soils.

The high montmorillonite and low kaolin content of the Sangamon soils also indicates that their resemblance to Red-Yellow

Podzolic soils is only superficial. Red-Yellow Podzolic soils may contain large amounts of montmorillonite but generally only in special cases when the parent materials were derived from montmorillonitic beds. Even these soils have high kaolin content compared with the Iowa Sangamon soils and they show a tendency for increase in kaolin and decrease in montmorillonite in the solum as compared with the subsoil.

The Gray-Brown Podzolic characteristics of the Sangamon soils indicate that the dominant vegetation on the landscape was forest. Simonson (60, p. 723) concluded that the geographic distribution of buried soils indicated that the pattern of forest and prairie on the former land surfaces must have been much like the native vegetative cover of the present plain. The distribution of the Gray-Brown Podzolic Sangamon soils along the traverse on the primary and secondary divides as well as down the flanks of the divide units indicates that the environment of the Sangamon surface was dissimilar to that of the present surface. The modern soils in the Wisconsin loess in all of these topographic positions are Brunizems developed under grass. A similar relationship occurs between the buried soils of the Late Sangamon erosion surfaces and the modern soils developed in Wisconsin loess.

Late Sangamon Surface

CHARACTERISTICS AND DISTRIBUTION

On the lower flanks of divide units, erosion bevels extend from the present valley walls of primary and secondary drainages up the flanks toward the crests of secondary and primary divides. Such erosion bevels flank both on the west and east the valley of Keg Creek (pl. I: 48, 46), on the west of the valley of Middle Silver Creek (40), on the west of the valley of the West Nishnabotna River (33, 32), on the east of the valley of the West Nishnabotna River (31, 30, 29, 28, 27), on the west of the valley of Indian Creek (11, 10, 9, 8), on the east of the valley of Indian Creek (7, 6, 5), on the west of the valley of the East Nishnabotna River (3, 2, 1), on the east of the valley of Turkey Creek (A, B, C), and on the west of the valley of Middle River (F, G, H).

Two exceptions occur along the traverse. Erosion bevels do not flank East Silver Creek (pl. I: 39-33). Instead, Loveland and Wisconsin loess mantle a pre-Loveland landscape in all cuts. The Loveland blankets the pre-Loveland landscape from an elevation of 1,180 feet in cut 36 to 1,237 feet in cut 39 on the west and 1,210 feet in cut 33 on the east. The occurrence of Loveland in this segment of the traverse yields the first line of evidence for the presence of erosion bevels flanking adjacent drainages. On the east flank of the divide unit of which cut 33 is the crest, an erosion surface bevels Kansan till at an elevation of 1,203 feet in cut 32 west of the West Nishnabotna River. The bevel is 20 to 25 feet above the lowest elevation of the surface on which the Loveland occurs in cut 36. But, in cut 32 the Loveland loess is absent. Higher up flank the Loveland occurs in cut 33. It must be concluded that the Loveland was stripped during the development of the erosion bevel in cut 32. Similarly, in cut 40 an erosion bevel

occurs at an elevation of 1,222 feet west of Middle Silver Creek. This erosion surface is 40 to 45 feet above the lowest elevation of the surface on which Loveland occurs (cut 36). These relationships occur on three adjacent primary and secondary divide units (pl. I).

The second exception occurs across Walnut Creek. Loveland loess occurs at an elevation below 1,260 feet in cut 13 (pl. I) that is bounded on the east by the valley of Walnut Creek and on the west by a valley of a tributary of Walnut Creek. Yet, east of Walnut Creek (cut 12) Loveland loess does not occur in its normal stratigraphic position at an elevation of 1,275 feet. West of the tributary of Walnut Creek (cut 14) Loveland loess does not occur in its normal position at an elevation of 1,285 feet. Apparently erosion bevels stripped Loveland loess to the east and to the west, but in centrally located cut 13 the Loveland was preserved.

These evidences indicate that Loveland loess once mantled the pre-Loveland surface in all of the cuts. Where the Loveland is now absent on low flank positions of divide units but present on higher flank positions, the Loveland has been stripped by post-Loveland erosion.

A second line of evidence for the post-Loveland bevel is the progressive exposure down flank on divide units of progressively older Pleistocene deposits. For example, in cut 26 (fig. 19) the Loveland loess occurs below the Farmdale increment of the Wisconsin loess. In cut 27 the Loveland is absent and the Farmdale overlies Yarmouth clay. In cuts 28 and 29 the Loveland and Yarmouth clay are absent, and the Farmdale overlies translocated sediment above a stone line on Kansan till. The unconformity increases in magnitude from the highest flank position (cut 26) where Farmdale overlying Sangamon soil in Loveland loess represents only a later part of the Sangamon. In cut 31 the disconformity of Farmdale overlying Nebraskan includes part of the Nebraskan, and the whole of the Aftonian, Kansan, Yarmouth, Illinoian, and Sangamon. Such angular truncation of the Pleistocene succession is excellent evidence of an erosion bevel that postdates not only the Loveland but the Sangamon maximum as well. The Sangamon maximum is represented by the intensely weathered solum in the uppermost part of the Loveland loess in cut 26.¹⁰

The most distinct field evidence of an erosion bevel is the occurrence of the stone line or lag gravel (fig. 20) on either the Kansan or Nebraskan tills from cuts 27 to 31 on the east side of the West Nishnabotna River (fig. 19) and in cuts 32 and 33 on the west side of the river. The lag gravel is identifiable discontinuously through a distance of $1\frac{2}{3}$ miles east of the east valley wall of the river and $\frac{3}{4}$ mile west of the west valley wall of the river. It is mantled by a translocated till-like sediment of lighter texture (less clay) than the underlying till and is related genetically to the cutting of the surface on the till. On sediment that

¹⁰ In cut 25 the B₂ horizon contains 55.3 percent clay and is a member of the sequence of Sangamon soils along the traverse.

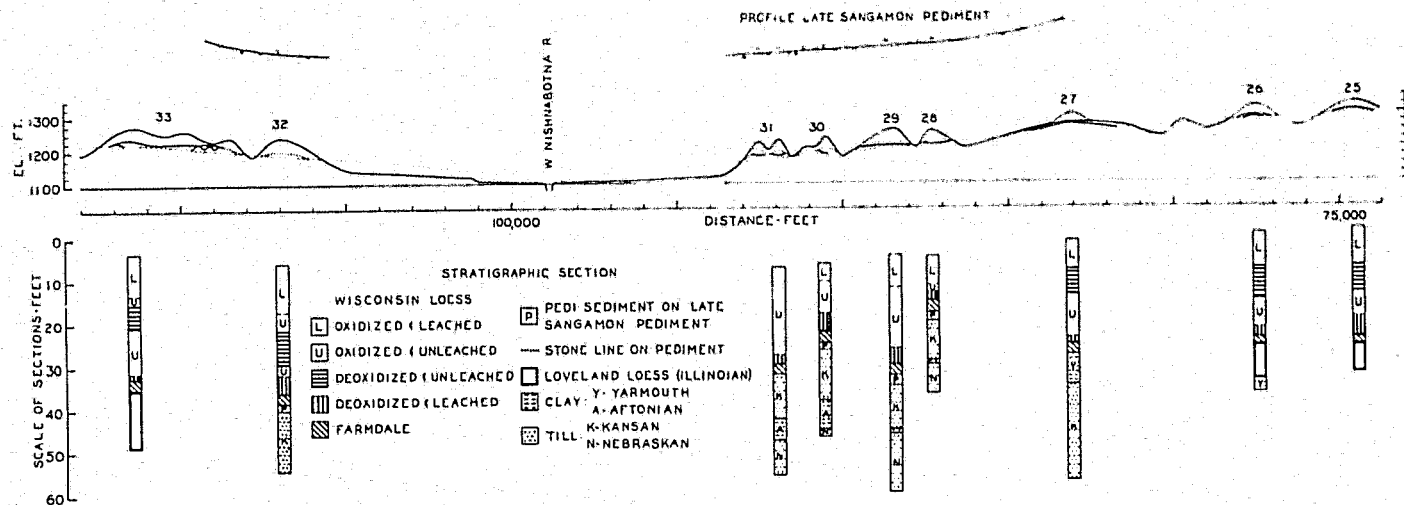

FIGURE 19.—Stratigraphic and geomorphic relationships of Late Sangamon erosion surface flanking West Nishnabotna River, cuts 33 to 25.



FIGURE 20.—Pedi-sediment overlying the stone line marking Late Sangamon pediment on Kansan till.

has no gravel-size components, such as Yarmouth clay, the erosion is defined by the angular unconformity that truncates a succession of older Pleistocene horizons.

AGE

The age of the erosion bevel flanking the major drainages is determinable stratigraphically (fig. 19). East of the West Nishnabotna River the bevel resulted in the stripping of Loveland loess on the flank of the divide unit west of and below cut 26. The intensely weathered Sangamon soil is present in the uppermost part of the Loveland loess in cut 26 and is comparable in development to the profile in cut 25 (fig. 16). The erosion bevel may be contemporaneous with or younger than the Sangamon soil in Loveland loess (Sangamon maximum).

The erosion surface west of the West Nishnabotna River (cuts 32-33) has stripped the Loveland loess in cut 32 and the east part of cut 33. One buried soil formed on the erosion bevel in the translocated sediment, stone line, and uppermost part of the Kansan till as in cut 31 (fig. 21). The buried soil is overlain by the buried Regosol in the basal Farmdale increment of the Wisconsin loess.

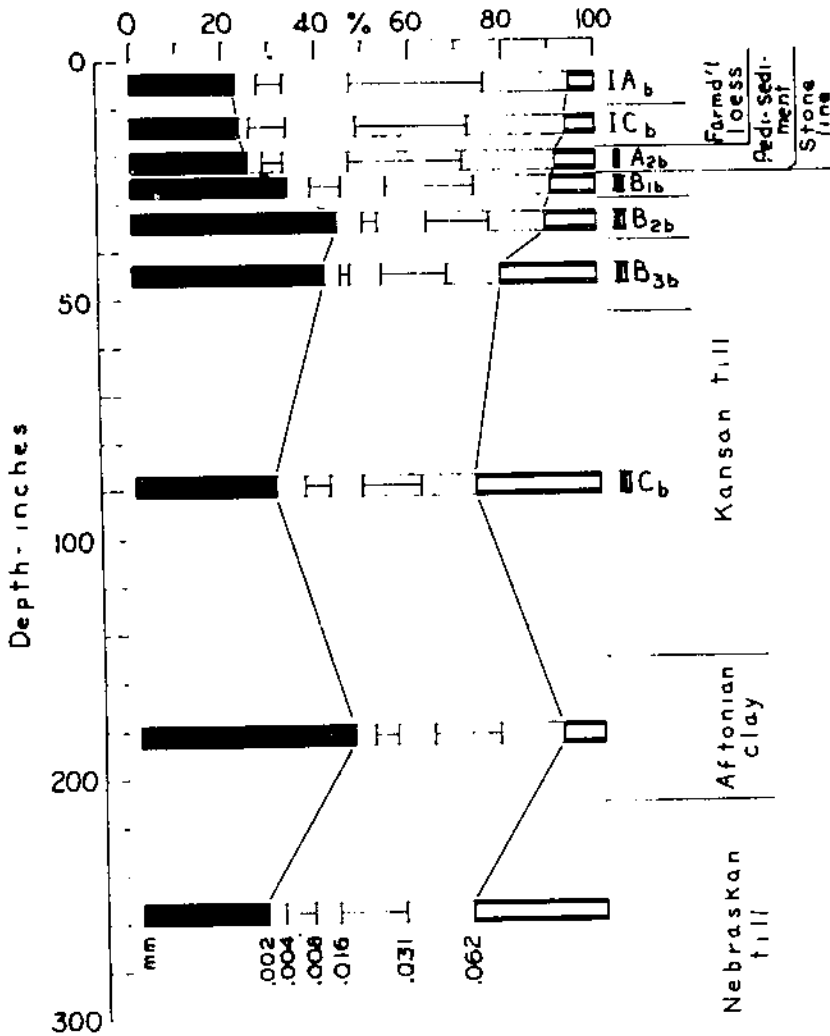

FIGURE 21.—Textural characteristics of Late Sangamon paleosol in pediment and Kansan till, and of stratigraphic section, cut 31.

There are two buried soils in the Loveland loess in cut 33 (fig. 10). The lower intra-Illinoian soil developed within the Loveland loess, and the upper Sangamon soil formed in the uppermost part of the Loveland loess. The Sangamon soil also is overlain by the buried Regosol of the Farmdale. The two buried profiles in Loveland loess occur within a depth of 133 inches below the base of the Farmdale. In cut 31 one buried soil occurs on the erosion bevel at a depth of 290 inches below the base of the Farmdale.

These relationships of angular truncation of Pleistocene horizons as well as zones of buried soils related to specific Pleistocene

horizons indicate that the erosion bevel is postmaximum Sangamon soil development but pre-Farmdale in age. Thus, the age of the erosion bevel is Late Sangamon.

The emplacement of Middle Silver and Graybill Creek and the establishment of the secondary divides, cuts 39 and 25, may be of similar age.

COMPARISON TO MODERN SURFACE

The Late Sangamon erosion surface crops out in the present valley walls above the present flood plains of the major drainages. Along Keg Creek (pl. I) the Late Sangamon bevel is at an elevation of 1,175 feet in cut 49, 52 feet above the flood plain of Keg Creek at an elevation of 1,123 feet. An alluvial fill of more than 50 feet occurs in the valley of Keg Creek.¹⁷

Along Middle Silver Creek the Late Sangamon surface crops out at 1,248 feet (cut 40), 66 feet above the modern flood plain of the stream at 1,182 feet. An alluvial fill of 58 feet overlies glacial till in the valley.

Along Graybill Creek the erosion bevel stands at 1,282 feet west of the valley (cut 23) and at 1,288 feet east of the valley (cut 22), 66 to 72 feet above the modern flood plain at 1,216 feet. An alluvial fill of 49 feet mantles glacial till in the valley.

Along Walnut Creek the Late Sangamon surface occurs at 1,283 feet west of the valley (cut 14) and 1,270 feet east of the valley (cut 12), and stands 47 to 60 feet above the modern flood plain at 1,223 feet. An alluvial fill of more than 50 feet occurs in the valley.

Along East Nishnabotna River, the erosion surface is at 1,225 feet west of the valley (cut 1), 83 feet above the modern flood plain at 1,142 feet. In the valley an alluvial fill of 37 feet mantles 12 feet of glacial till which in turn overlies the Dakota sandstone (Cretaceous).

These data show that in the modern valley walls of major drainages the Late Sangamon erosion surface stands at an average of 60 to 65 feet above the levels of the modern flood plains along the drainages.

The slopes of the valley walls angularly truncate the Late Sangamon bevel so that the valley slopes must be post-Late Sangamon in age. Alluvial fills in these valleys of 37, 49, 58, and unknown thicknesses greater than 50 feet show that post-Late Sangamon valley incision progressed to depths of 120 or more feet below the Late Sangamon surface.

The Late Sangamon bevel flanking the West Nishnabotna River (fig. 19) stands at 1,167 feet in the east valley wall and at 1,180 feet in the west valley wall. The modern flood plain at 1,102 feet is 65 feet below the Late Sangamon surface on the east side of the valley. On the west side of the valley the erosion surface is 61 feet above the level of the Iowan terrace. The terrace is 17 feet

¹⁷ Records of borings for bridge sites along the railroad relocation were obtained through courtesy of Rockwell Smith, Research Engineer Roadway, Association of American Railroads, from the Office of Bridge Engineer, Chicago, Rock Island, and Pacific Railroad.

above the modern flood plain. An alluvial fill of more than 50 feet occurs below the flood plain in the valley.

CLASSIFICATION

East of the West Nishnabotna River elevations on the Late Sangamon erosion surface progressively increase from 1,167 feet at the west end of cut 31 to 1,245 feet in cut 27 to the east (fig. 19). On the west side of the river elevations on the Late Sangamon bevel progressively increase from 1,180 feet in the east end of cut 32 to 1,210 feet in cut 33 to the west. Throughout the major parts of both segments, the erosion surface is marked by the stone line. Maximum local relief on the erosion surface east of the river is 15 to 20 feet, and west of the river, 10 feet. The surface extends 2 miles east of the river and $\frac{3}{4}$ mile west of the river.

A median curve (fig. 19) through the points of maximum and minimum elevations on the Late Sangamon surface is curvate, concave upward, and conforms to the classical hydrologic profile of fluvial erosion. Such erosion-surface profiles have been described as characteristic of pediments (6, pp. 46-48; 7, p. 259; 29, pp. 728-730; 15, p. 89).

A pediment is an erosion surface that lies at the foot of a receded slope, is underlain by rocks or sediments of the upland, is barren or mantled by a layer of alluvium (pedi-sediment), and displays a longitudinal profile normally concave upward. (Modified after Howard, 20, p. 8.) The pediment footslope is the surface of low gradient that extends from the foot of and away from the receded slope. The pediment backslope (the receded slope) is generally concave upward and rises from the pediment footslope to the upland.

A second characteristic of the Late Sangamon surface that typifies it is the translocated till-like sediment that mantles the erosion-surface lag gravel (figs. 15, 20). Such sediment veneer also has been considered characteristic of pediments (6, p. 57; 29, p. 730; 16, p. 245). Sediment veneering a pediment has been designated as pedi-sediment (50).

The occurrence of the Late Sangamon bevel on the flanks of, but below divides not truncated and unmodified by the lower level erosion bevel (fig. 19), conforms to the general concept of a pediment (16, p. 743). Occurrence of the Late Sangamon surface in geographic positions flanking major drainages suggests that the surface may conform to the *flanking pediment* of Frye (15, pp. 88-92; 16, p. 246).

On the foregoing bases the Late Sangamon erosion surfaces flanking the West Nishnabotna River (fig. 19) are pediments. The pediment surface, if extended toward the river, crosses the valley 50 to 60 feet above the modern flood plain. Apparently, the pediment was developed when the ancestral Nishnabotna River of Late Sangamon time stood at a higher elevation than that of the present stream.

There is other evidence of such higher levels of the major drainages along the traverse. For example, along Indian Creek (fig. 22) the base of a leached sand and gravel crops out in the east valley

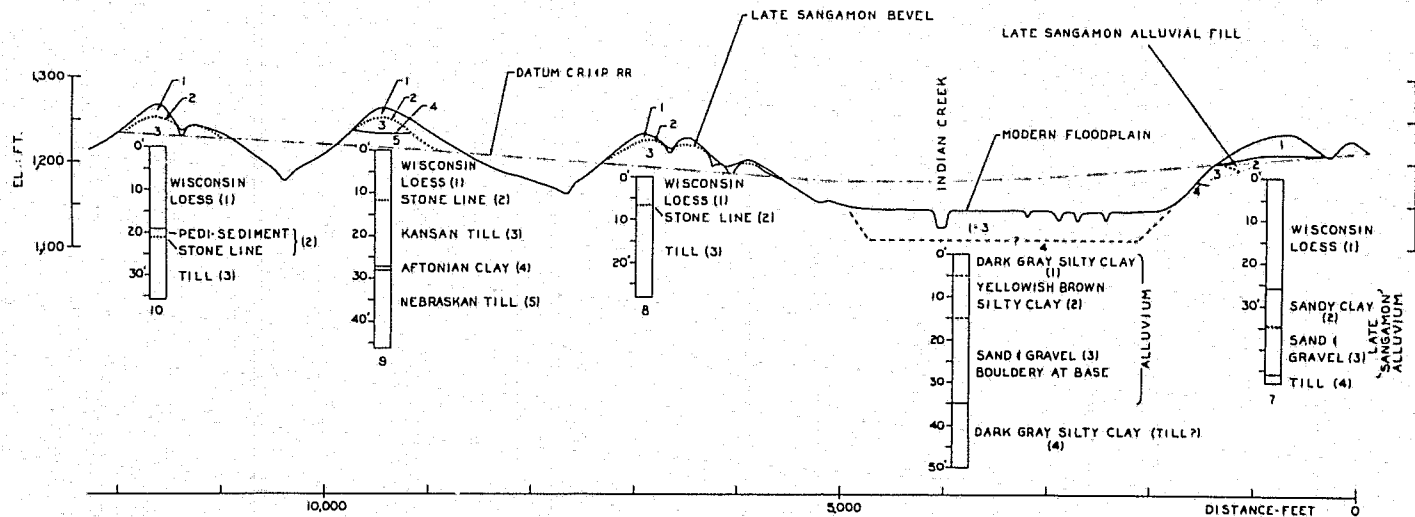

FIGURE 22.—Relation of Late Sangamon alluvial valley fill and Late Sangamon erosion surface along Indian Creek, cuts 10 to 7.

wall 35 feet above the modern flood plain along the stream. The yellowish brown sand and gravel is more than 12 feet thick and grades upward into a reddish brown sandy clay that in turn is overlain by at least 8 feet of a reddish brown silty clay (fig. 23).

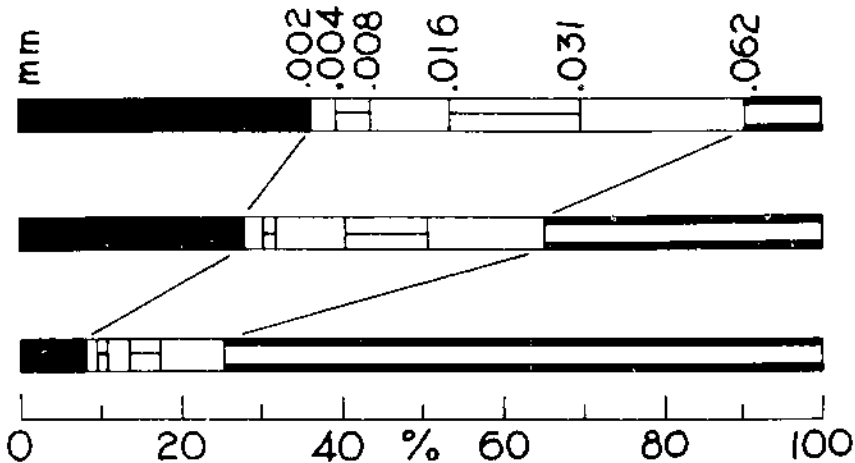

FIGURE 23.—Textures of Late Sangamon alluvium, cut 7.

The sediment is comparable in texture and bedding to terrace sediments or flood-plain alluvium of the present valleys.

The sediment occurs on the lowest flank position of the Late Sangamon bevel that rises to the divide at cut 4 to the east (pl. I). In the west valley wall of Indian Creek (fig. 22, cut 8) the Late Sangamon bevel crops at an elevation accordant with the alluvium in the east valley wall in cut 7. These lines of evidence indicate that in Late Sangamon time an alluvial valley fill along the present course of Indian Creek occurred at an elevation 62 feet above the level of the modern flood plain. The evidence further suggests that the Late Sangamon bevel west of Indian Creek was graded eastward to the high-standing valley fill.

Pediments that are correlative of the Late Sangamon surfaces flanking West Nishnabotna River and Indian Creek occur along Keg Creek and Middle Silver Creek (pl. I), Graybill and Walnut Creeks, and East Nishnabotna River, Turkey Creek, and Middle River.

The characteristics of the Late Sangamon pediments are: (1) geographic occurrence flanking major drainages, (2) geographic occurrence on the flanks of divide units, (3) concave upward profile up flank toward the divides, (4) angular truncation of the Pleistocene succession on the flanks of divide units, and (5) occurrence of lag-gravels veneered by pedi-sediments. These characteristics show that the pedimentation process was essentially a wearing back of the landscape from the major drainages toward the divides of the prepediment landscape.

The fact that the divides remained unmodified by the Late Sangamon pedimentation is demonstrated stratigraphically on the

West Nishnabotna bevel (fig. 19). The Loveland loess has not been stripped from the divides at cuts 33 and 26-25. The divides, although unmodified by erosion, were subjected to intensive weathering (figs. 16, 17). The divides have been stable landscape units since at least the beginning of Illinoian time.

PALEOSOLS

The stability of divides in the evolution of the landscapes along the traverse is best exemplified in the traverse across the divide unit at Adair (pl. I). The buried landscape on the divide is characterized by the deep, intensely weathered Humic-Gley paleosol (gumbotil) in Kansan till. On the west flank toward Turkey Creek, the Late Sangamon pediment is preserved in cuts A, B, C, and on the east flank toward Middle River in cuts F, G, H. The following section occurs in cut A:

Section H:

Wisconsin loess:

Oxidized and leached Dark yellowish brown to brown (10YR 4/4-5/4) silt loam; massive; friable; leached.

0-42 inches
below modern surface

Deoxidized and leached Gray (10YR 5/1) to light gray (10YR 6/1) silt loam; massive; friable; iron oxide segregated in pipestems; leached.

42-60 inches

Farmdale:

1A₁₀

60-70 inches

Grayish brown to brown (10YR 5/2.5, dry) and dark grayish brown to dark brown (10YR 4/2.5, moist) silt loam; weak platy to weak fine granular; hard yellowish red (5YR 5/6) to dark reddish brown (5YR 3/3) iron oxide concretions very abundant, friable; leached.

Late Sangamon soil in Kansan till:

11A₁₀

70-76 inches

Light brownish gray to pale brown (10YR 6/2.5, dry) and brown to yellowish brown (10YR 5/3.5, moist) silt loam; weak platy to weak medium granular; hard when dry, friable when moist; hard yellowish red to dark reddish brown iron oxide concretions very abundant; gritty; leached.

11B₁₀

76-84 inches

Brown (7.5YR 5/4, dry) to dark brown (7.5YR 4/4, moist) silty clay loam; moderate fine to medium subangular blocky; hard when dry, firm when moist; clay skins prominent; hard yellowish red to dark reddish brown iron oxide concretions abundant; gritty to pebbly; leached.

11B₂₀

84-99 inches

Reddish brown to yellowish red (5YR 4/5, dry) and yellowish red (5YR 4/6, moist) to brown (7.5YR 4/4, moist) clay; strong medium subangular blocky; very hard when dry, firm but plastic when moist; clay skins very prominent; hard yellowish red to dark reddish brown iron oxide concretions abundant; very gritty to cobbly; leached; stone line at top.

11B₃₀

99-106 inches

Brown to yellowish brown (10YR 5/3.5, dry) and dark brown to dark yellowish brown (10YR 4/3.5, moist) clay loam; moderate medium subangular blocky; hard when dry, firm when moist; clay skins common; hard yellowish red to dark reddish brown concretions sparse; gritty to pebbly; leached.

11C₁₀

106-160 inches

Brownish yellow (10YR 6/8, dry) to yellowish brown (10YR 5/7, moist) clay loam; coarse angular blocky; hard when dry, friable when moist; hard yellowish red to dark reddish brown iron oxide concretions sparse; oxidized and leached Kansan till.

11C₂₀

160-238 inches

Pale yellow (2.5Y 7/4, dry) to yellowish brown (10YR 5/8, moist) clay loam; coarse angular blocky; hard when dry, firm

when moist; gritty to cobbly; oxidized and unleached Kansan till.

IIC_{2b}, 238-330 inches Dark gray (10YR 4/1, moist) clay loam; coarse angular blocky; hard and firm; gritty to cobbly; unoxidized and unleached Kansan till to base of cut.

Petrographic analysis of the sand fraction of this buried soil shows that the profile is not intensely weathered. Weatherable mineral particles such as granite, basalt, and gabbro are present throughout the profile: Ia_{1b}, 18 percent; IIA_{2b}, 11 percent; IIB_{1b}, 10 percent; IIB_{2b}, 12 percent; IIC_{1b}, 7 percent. The depth below the top of the solum to the zone of most readily weatherable material, such as limestone and dolomite, is 90 inches.

The buried solum contains hard yellowish red to dark reddish brown iron oxide concretions that are concentrated in greatest quantity above the IIB_{2b} horizon: IA_{1b}, 17 percent; IIA_{2b}, 13 percent; IIB_{1b}, 5 percent; IIB_{2b}, 8 percent; IIC_{1b}, 1 percent. This buried soil, similar to the Yarmouth-Sangamon paleosol at Adair, apparently has had additions of iron oxide subsequent to horizon development. The IIB_{2b} horizon acted as a lower, impermeable barrier above which iron oxide was precipitated. Major concentrations in the Farmdale IIA_{1b} suggests that the iron oxide may have been derived from weathering of the overlying post-Farmdale Wisconsin loess.

The thickness of the solum of the Late Sangamon buried soil is only 36 inches. The clay ratio of the B-C horizons is 1.2:1.0. The morphological and mineralogical characteristics on the flanking pediment are compared to the characteristics of the buried soil of

TABLE 18.—Comparison of morphological and mineralogical characteristics of the buried soils of the Late Sangamon flanking pediment and the stable Yarmouth-Sangamon divide on the divide unit, Turkey Creek-Adair-Middle River

Characteristics	Yarmouth-Sangamon stable divide (cut D)	Late Sangamon flanking pediment (cut A)
	<i>Inches</i>	<i>Inches</i>
Thickness of solum.....	113	36
Thickness of B ₂ horizon.....	53	15
Depth to weatherable minerals ¹	120	0
Depth to carbonate.....	147	90
	<i>Ratio</i>	<i>Ratio</i>
Clay content B-C horizons.....	1.5:1.0	1.2:1.0
	<i>Percent</i>	<i>Percent</i>
Weatherable minerals ¹		
A ₁ horizon.....	0.0	18.0
A ₂ /A ₃ horizons.....	0.0	11.5
B ₁ horizon.....	0.0	10.0
B ₂ horizon.....	0.0	11.8
B ₃ horizon.....	0.0	-----
C ₁ horizon.....	3.6	7.5
C ₂ horizon.....	12.6	-----
C _{en} horizon.....	22.0	15.5

¹ Sand fractions.

the stable divide at Adair in table 18. The data indicate: (1) That the stable Yarmouth-Sangamon divide has remained unmodified by erosion but has been subjected only to intensive weathering with the development of a deep soil. (2) The development of the Late Sangamon flanking pediment has stripped the intensively weathered soil of the older landscape and exposed fresh mineral material to a new cycle of soil genesis. On the younger surface a shallow, less intensely weathered soil has formed.

CONCEPT OF EVOLUTION

The stratigraphic relationships of the Pleistocene deposits, the physiographic expression of the flanking erosion bevels to crests of divide units and to the stratigraphy, and the geographic expressions of soils relative to the physiography and stratigraphy establish the fundamental theorems of landscape evolution. (1) Fluvial erosion surfaces develop from a directrix—a controlling stream—and encroach on and up the flanks of adjacent interfluves toward the divides. (2) The profile of the encroaching erosion surface is curvate, concave upward, toward the periphery of the watershed in which it develops. (3) The encroaching erosion strips the products of weathering of older surfaces; a younger, fresh surface is formed; and a new cycle of soil formation begins. (4) The divides remain as stable landscapes subjected to intensive weathering until they are beveled by the encroaching erosion surface. (5) The divides are not worn down but ultimately may be destroyed by the encroachment of erosion bevels from opposite directions.

Theorems such as these have been designated by King (29) as *Canons of Landscape Evolution*. Although a strong advocate of the concept of pediplanation, King, as well as most geomorphologists, ignores the characteristics and geomorphic distribution of soils in studies of landscapes (cf., theorems 3 and 4).

It is generally accepted that weathering, erosion, and sedimentation are phases of the modification of a landscape by fluvial processes. Most geomorphic studies have attempted to evaluate the stage and process of evolution of landscapes by studying erosion and sedimentation but have neglected weathering except in a superficial way. Weathering results in the formation of soils that have evaluable characteristics and geographic distribution.

The occurrence of well-developed, deep soils on an old landscape that stands above a younger, beveled surface substantiates the concept of pediplanation. The part of a landscape that permits deep, intensive weathering and soil formation is one on which little or no erosion is taking place.¹⁵ In the concept of pediplanation (29, p. 743) land surfaces may survive long after the beginning of a new erosion cycle. The old surfaces remain practically unaltered erosionally until destroyed by the encroachment of the new cyclic surface. Weathering should proceed on the old surface (fig. 24, stages 1 to 5) with the formation of maximal-type soils

¹⁵ Assuming that the parent material, climate, and biotic factors are suitable.

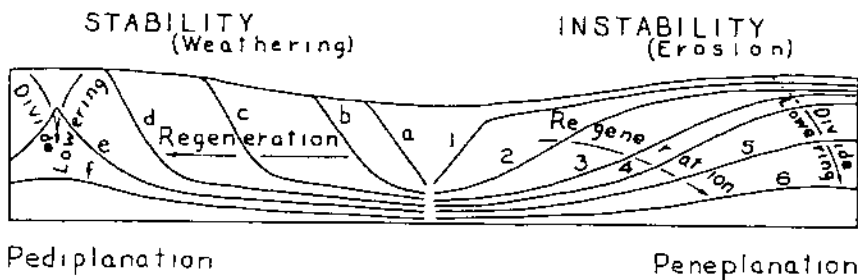

FIGURE 24.—Diagrammatic contrast of the backwearing (pediplantation) and downwearing (peneplanation) concepts of landscape evolution. Modified after Davis (*12*, p. 409).

that remain on the divides as remnants of the old landscape until the divide is beveled by the encroaching pediment (stage 6). Soils of the regenerated soil landscape of the encroaching pediment should show marked contrast to the soils of the old stable landscape of the divide if sediment derived from the older weathered material is not deposited as a veneer on the younger surface.

Well-developed intensely weathered soils on the surface at a higher elevation than a younger curvate one with less intensely weathered soils disputes the hypothesis of landscape evolution by the process of peneplanation. In peneplanation, with concurrent downwearing of the divides (fig. 23, A to F), erosion should progress with "grading" of the slopes such that weathering would be balanced by or subordinated to concurrent erosion (stages C to F). As a result, maximal soils would develop on divides only after base leveling (stage F). If such is the case, there should be little significant difference in soils in a catena.¹⁹ However, most minimal members of a catena occur on slopes and most maximal members on level to rounded summits. Such soil-geographic evidence indicates that the summits are not being lowered but remain essentially stabilized until truncated by the encroachment of a lower bevel-pediplanationation.

It should be noted that the end results of both processes are comparable landscapes (cf., fig. 24, stages 6 and f) upon which similar catenary associates of maximal soils may develop. The initial stages of both processes are comparable (stages 1 and a). The conflict comes in the intervening stages. The geography of soils relative to physiographic expression substantiates the backwearing concept but disputes the downwearing one.

In the genesis of soil landscapes, corollaries of the fundamental theorems of landscape evolution are: (1) On stable uplands, soils will continue to develop practically unmodified by erosion. (2) Soil landscapes on slopes or on flanks of uplands will become truncated progressively upslope or upflank. (3) A new cyclic soil landscape will develop contemporaneously with the progressive upflank truncation. (4) The old soil landscape will be beveled ultimately with an impression of a new cycle of soil genesis.

¹⁹ A soil catena is defined as a group of soils on a landscape that are derived from similar parent material and that occur in a complex in which the individual members are differentiated by topographical and hydrological conditions (*37*, p. 16).

VEGETATION

The soils on the Late Sangamon pediments are similar to the soils of the Sangamon landscape in that they have morphological and textural characteristics that are similar to those of modern Gray-Brown Podzolic soils (9, p. 973; 71, p. 120). The buried soils indicate that the vegetative cover on the Late Sangamon surface was dominantly forest. In contrast, the soils on the Wisconsin loess, which overlies the Late Sangamon pediments, are Brunizems (Prairie soils).

There are several other evidences of forest vegetation during Late Sangamon time. A radiocarbon sample from near Independence, east-central Iowa, on the Late Sangamon surface was dated at greater than 38,000 years before present (43, W-139). Wood from the radiocarbon horizon was identified as hemlock.²⁰ Lane (32, pp. 256-259) has shown the dominance of spruce-pine pollen in an analysis of a Late Sangamon peat bog in southeastern Iowa.

Apparently during the period preceding Wisconsin glaciation, possibly by 10,000 to 15,000 years, a forest cover dominated the landscape. The characteristics of the soils of the Late Sangamon pediments and the Sangamon uplands that remained stable during Late Sangamon time and the paleobotanical evidence indicate a forest environment.

The Late Sangamon forest cover, hemlock, pine, larch, and fir,²¹ is not in Iowa at the present time but is characteristic of the latitudes of northern Minnesota and southern Canada where mean annual temperatures are 5 to 10 degrees colder than in Iowa. A comparable climatic regime probably existed in Iowa toward the end of Late Sangamon time, and undoubtedly foreshadowed the advent of Wisconsin glaciation.

Wisconsin Surface-Complex

The Wisconsin geomorphic surface is a complex continuum that is the present land surface along the traverse. It is composed of: (1) An earliest Wisconsin surface of dissection, (2) an Early Wisconsin terrace along the primary drainages, (3) a Late Wisconsin²² surface of dissection, and (4) a Recent gully cut and fill surface.

The Late Sangamon surface has been shown to be one of low relief (figs. 19, 22). For example, along Indian Creek the maximum relief between the top of the Late Sangamon valley fill in cut 7, at an elevation of 1,202 feet, is only 95 feet below the crest of the divide of the pre-Wisconsin surface in cut 5 at 1,297 feet. The distance is 1 1/2 miles. The modern surface has a relief of 175 feet between the modern flood plain along Indian Creek at 1,142 feet and the crest of the divide in cut 5 at 1,317 feet. Maximum relief is 210 feet including the alluvial fill in the valley of Indian Creek. An increase of relief of the order of 2 to 2 1/2 fold

²⁰ Identification of wood by D. W. Benseid, Dept. Forestry, Iowa State College.

²¹ Radiocarbon sample W-139, and see Lane (32, p. 257).

²² Early Wisconsin refers to Farmdale, Iowan, and Tazewell, and Late Wisconsin to Cary and Mankato. See Ruhe (45).

has occurred since Late Sangamon time. The modification of the landscape has been the result of dissection, alluviation in the valleys, and loess sedimentation on the ridges. The Wisconsin age of the dissection is shown by the angular beveling of the Late Sangamon valley fill along Indian Creek.

Early Wisconsin Surface of Dissection

The major part of the dissection of the Late Sangamon landscape occurred in earliest Wisconsin time. Wisconsin loess on slopes that angularly bevel the Late Sangamon pediments indicates that the slopes are post-Late Sangamon (fig. 25). The loess has been shown to be dominantly of Iowan and Tazewell age. Therefore the slopes must be older than the loess. In cuts B and H slopes angularly truncate the Late Sangamon pediment. The Early Wisconsin loess on the slopes below the pediment indicates that the slopes are post-Late Sangamon pediment but pre-loessial. The cause of dissection probably is related to increased precipitation in the transition from the Sangamon interglacial age to the Wisconsin glacial age. The dissection may be designated as earliest Wisconsin.

Early Wisconsin (Iowan) Terrace

Further evidence of the dissection of the Late Sangamon surface during earliest Wisconsin time is a terrace along the valleys of the primary drainages, West and East Nishnabotna Rivers (10, pp. 345-349).

The surface of the terrace along the West Nishnabotna River stands 17 feet above the modern flood plain of the stream and that of the terrace along the East Nishnabotna River stands 22 feet above. The terrace along the West Nishnabotna River has been traced northward through Pottawattamie and Shelby Counties into Carroll County where the alluvial-terrace fill debouches from the Iowan drift lobe. The terrace along the East Nishnabotna River has been traced northward through Cass and Audubon Counties into Carroll County where the alluvial-terrace fill also debouches from the Iowan drift lobe. The margin of the Iowan drift lobe in Carroll County, originally mapped by Smith and Riecken (64) extends southward into the southern tier of townships in Carroll County, (10, pp. 345-347) as far as Manning and Templeton. Tracing of the terrace fills in the Nishnabotna valleys to the Iowan sublobe shows that the fills were probably outwash-alluvium valley trains related to the sublobe.

Thus, the valleys of the rivers were formed prior to Iowan glaciation. The occurrence of Iowan-Tazewell loess on the terraces further substantiates this conclusion.

Late Wisconsin Surface of Dissection

An angular bevel on the slopes of the landscapes along the traverse shows dissection of Late Wisconsin age. In the eastern segment of the traverse (fig. 25, A, C) not only has the Late Sangamon surface been beveled, but the Iowan-Tazewell loess has

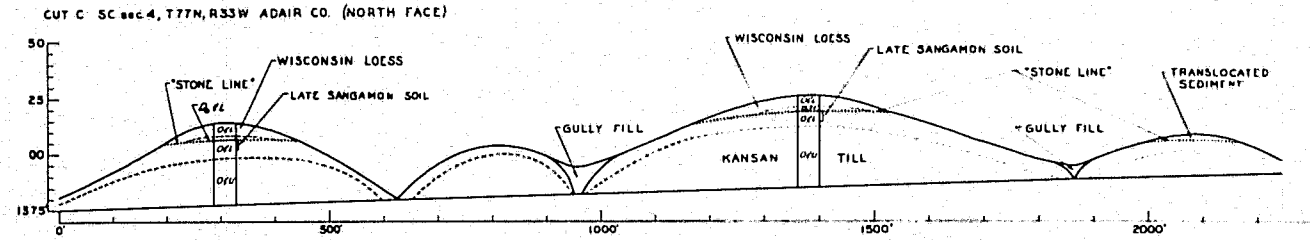
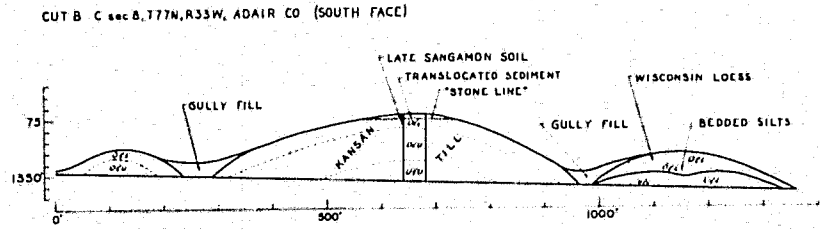
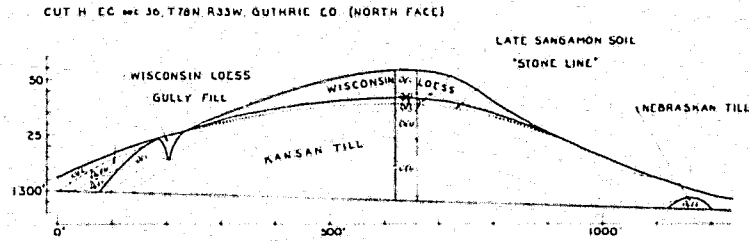
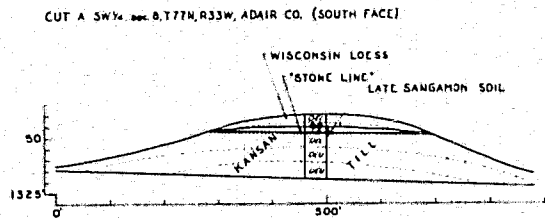

FIGURE 25.—Occurrence of Iowan and Tazewell loess on slopes that bevel the Late Sangamon pediments, cuts A, B, C, and H.

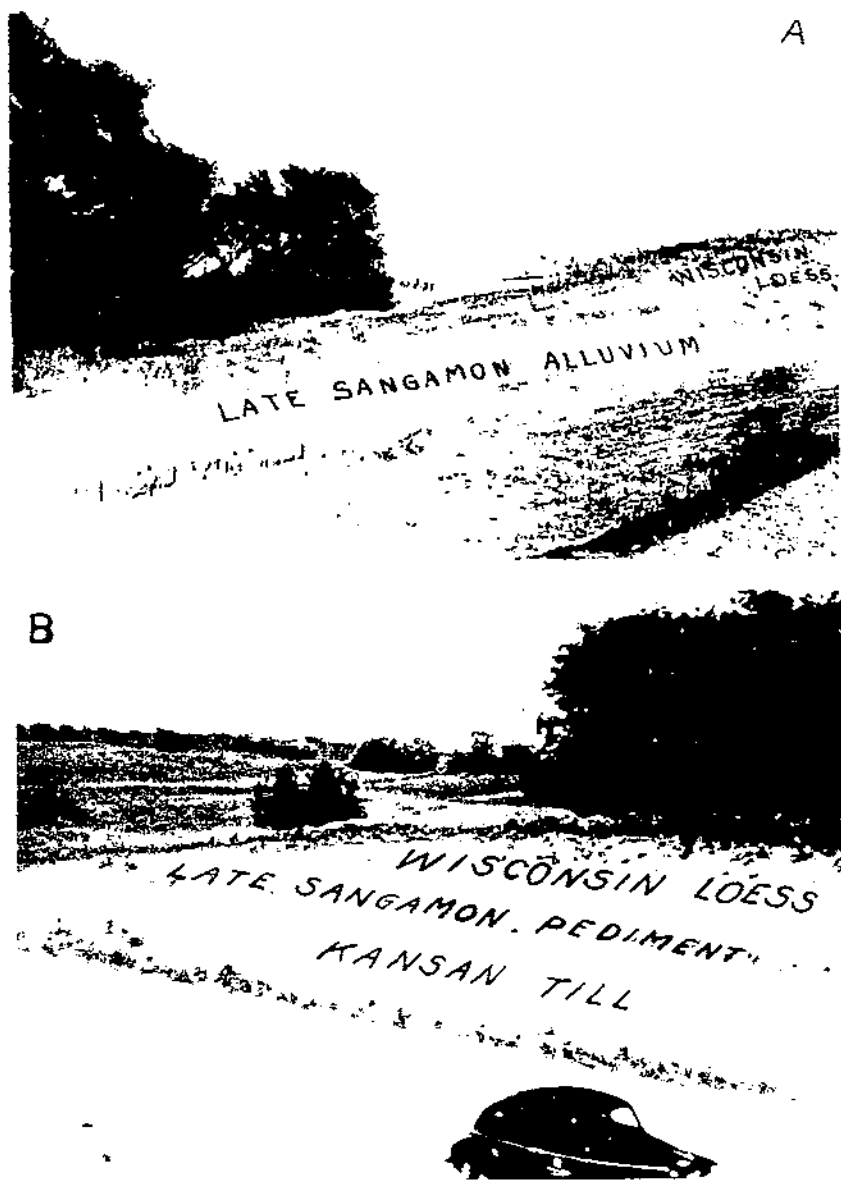

FIGURE 26.—Late Wisconsin—Recent beveling of the Iowan-Tazewell loess and Late Sangamon surface: A, cut 7; B, eastern segment of traverse.

been stripped as well (fig. 25, B, H). Iowan-Tazewell loess does not occur on the slopes below the Late Sangamon pediment (fig. 25) indicating that the Early Wisconsin loess has been stripped. In cut 7 (fig. 26) on the east valley slope of Indian Creek the Iowan-Tazewell loess has been stripped from the Late Sangamon alluvial-valley fill.

The upper limit of the age of the slopes that bevel the Late Sangamon surface and the Early Wisconsin loess cannot be fixed with certainty. Some may be of very recent age.

The Iowan terrace in the valleys of the Nishnabotna Rivers above the flood plains of the streams is also indicative of Late Wisconsin dissection. In the West Nishnabotna Valley more than 50 feet of alluvium fills the valley below the level of the modern flood plain. In the East Nishnabotna Valley is an alluvial fill of 37 feet in the east side of the valley. Although the evidence at hand does not permit assignment of the entire deep cutting and thick filling below the level of the Iowan terrace only to Late Wisconsin time, the relationships indicate considerable dissection and filling in the valleys subsequent to Iowan alluviation and Iowan-Tazewell loess deposition.

More evidence of Late Wisconsin dissection is the relationship of slope bevels to the weathering and faunal zones in the Iowan-Tazewell loess (fig. 11). In cut 50 the upper gleyed deoxidized and unleached zone (zone 3) coincides with the lower faunal zone, Iowan-Tazewell transition. In cut 45 the upper deoxidized and unleached zone (zone 3) coincides with the upper faunal zone, Tazewell. The relationships of weathering and faunal zones in cut 39 are similar to those in cut 45. In cuts 25 and 17 the upper deoxidized and unleached zone (zone 3) is coincident wholly or in part with the lower faunal zone, Iowan-Tazewell transition. In cut 11 the upper deoxidized and unleached zone (zone 3) occurs above the lower faunal zone, Iowan-Tazewell transition. These detailed relationships show that the weathering zone, the gleyed deoxidization and unleached zone, is independent of stratigraphic zonation of the loess and must represent change after loess deposition. The age of the weathering zone therefore must be post-Tazewell or Late Wisconsin.

In the western part of the traverse, slopes of the present landscape angularly bevel the weathering zones in the loess. In cut 42 (fig. 11) the gleyed loess (zone 3) is angularly beveled by the west slope. The slope is younger than the age of the weathering zone and therefore must be not older than the Late Wisconsin. The upper limit of the age of the slopes that bevel the weathering zone can be fixed by determination of the age of the gully fill at the west end of cut 42. Some of the slopes may be of Recent age.

The cause of the Late Wisconsin dissection that resulted in the beveling of the Late Sangamon surface and Early Wisconsin loess, the trenching of the Early Wisconsin (Iowan) alluvial fill in the valleys with subsequent valley filling, and the beveling of the weathering zones in the Early Wisconsin loess is probably the climatic change toward a more humid regime that must have been related to the glaciations of the Cary and Mankato which followed the Early Wisconsin events (45).

The origin of the upper deoxidized and unleached weathering zone in the Iowan and Tazewell loess is believed to be the result of a more humid climatic regime. The zone conforms to the accepted concept of a G horizon (67, p. 180) in that the zone has neutral gray colors that commonly change to grayish brown upon exposure to air. The deoxidized loess is apparently a zone of intense reduction that was caused by saturation of the zone with water in the presence of organic matter. Reoxidation of the zone while buried is shown by yellowish brown to reddish brown pipe-stems along tubules of aeration. Reoxidation upon exposure is shown by the change of color from gray to brown. Abundant, prominent gray mottles in the oxidized zone above the deoxidized zone further suggests impeded drainage during formation of the massive gleyed horizon.

The geomorphic evidence along the traverse shows that Iowan and Tazewell loess was deposited upon a landscape that had been subjected to earliest Wisconsin dissection. The faunal evidence in the loess shows that the upper gleyed zone was impressed on the loess subsequent to loess deposition. Although the degree of dissection in Late Wisconsin time cannot be evaluated specifically, drainage of the loessial landscape at the beginning of Late Wisconsin time may not have been greatly different from that of the present landscape. The present landscape under the current climatic regime does not permit permanent saturation of the loess in the upper gleyed deoxidized and leached zone. Thus, it must be concluded that the gleyed zone was a result of a past climatic regime of greater humidity. Such a climatic regime during the Late Wisconsin undoubtedly was responsible for the Cary and Mankato glaciations.

The regional occurrence of the deoxidized zones above the more impermeable B₁ horizons of the Sangamon and Late Sangamon soils suggests that a perched zone of saturation above the older soils was not impossible. On the present landscape after the spring thaw and rains perched zones of saturation are in the basal part of the Wisconsin loess above the Sangamon and Late Sangamon soils. These perched zones coincide with and in part may be responsible for the lower deoxidized and leached loess.

Recent Gully Cut-and-Fill Surface

Regional distribution of a gully cut and fill surface from the west end to the east end of the traverse (figs. 6; 24, B, C, H; 30) suggests that the cuts and fills are of one cycle.

In cut 39 (fig. 6) the gully truncates progressively downward the Wisconsin loess with its two faunal zones and the Late Wisconsin gleyed zone, as well as the Farmdale and upper part of the Loveland loess. In cut 42 (fig. 30) the gully cycle also bevels the faunal and weathering zones. Thus, the gully cycle post-dates the Late Wisconsin.

The gully fills along the traverse are on the uplands well above the adjacent modern valleys. For example, in cut 39 the base of the gully fill is 65 feet above the valley bottom of Middle Silver

Creek to the west. The base of the gully fill in cut C is 50 feet above the bottom of the present valley just west.

A radiocarbon sample extracted 1 foot above the base of the gully fill in cut 39 has been dated at $6,800 \pm 300$ years (44, W-235). The radiocarbon date indicates that the gully cut and fill surface is Recent in age. The slopes that extend from the gully fill to the ridge summits to the west and to the east must be as young or younger than the gully fill. Soils on the slopes also must be of Recent age (chap. 4).

Relation of Pleistocene Stratigraphy and Geomorphology to Soils

Soil is defined and explained (67) as the collection of natural bodies occupying portions of the earth's surface that support plants and have properties due to the integrated effect of climate and living matter, acting upon parent material, as conditioned by relief over periods of time. Soil, then, is the natural medium for the growth of land plants, whether or not the soil has horizons. In this sense soil covers land as a continuum. As an individual in the continuum, a soil is a dynamic three-dimensional piece of landscape that supports plants. Thus, soils are landscapes as well as profiles.

To better understand the genetic, geographic, and classification characteristics of soils, a fundamental knowledge of the nature and history of the landscape is essential. The study of such nature and history of a landscape is the science of geomorphology. Landscapes are three-dimensional in that they have a geographic distribution and that they form in and on material. An evaluation of the soil landscape along the traverse in southwestern Iowa must take into account not only the nature and history of the present land surface but an evaluation of the Pleistocene deposits and past geomorphic surfaces to which the present land surface is related. The complexities of the sequence of Pleistocene deposits and the nature and history of past and present land surfaces have been detailed. The soils of the present land surface are no more than the current expressions of the history. Thus, the relationships of the soils can best be explained by a historical approach, interrelating the geomorphic surfaces and events.

Yarmouth-Sangamon Surface, Late Sangamon Pediment, and Wisconsin Dissection

YARMOUTH-SANGAMON AND WISCONSIN DISSECTION SOIL LANDSCAPE

The buried soil of the Yarmouth-Sangamon surface (fig. 15) has a deep, intensely weathered profile. This buried soil has been exposed by Wisconsin dissection that probably began in Early Wisconsin time. On the east and west slopes of cuts D and E it has become a part of the continuum of soils on the modern surface. This is a geologic accident, in that the morphological and genetic characteristics of the soil are in no way related to the present but are relict of paleo-environment.

The cropping out of the old soil on the modern surface is common in the southern half of Iowa. There the paleosol is generally called gumbotil. The paleosol at Adair is a Humic-Gley soil, one kind of paleosol that is characteristic of the Yarmouth-Sangamon surface (60, pp. 711-716). Where Humic-Gley soils of the old landscape crop out, they are classified as the Clarinda silt loam (57, pp. 38-41).²³

The Yarmouth-Sangamon paleosols are on the highest positions of divide units and are related to the geomorphic evolution of the landscape (fig. 27, A). In areas outside the influence of Loveland loess deposition the Clarinda silt loam or its planosolic analogue are high on the flank or on the crests of divide units. However, comparable buried soils on the Nebraskan till, which formed during the Aftonian interglacial interval, may complicate the soil-geography pattern. Progressive downflank truncation of the Pleistocene succession may result in exposure of the Aftonian buried soil (gumbotil) lower on the flanks of divide units. In some cases the two paleosols may crop out on the same hill slope.

On local soil-landscape units the Clarinda silt loam or planosolic analogue occur in a sequence relationship (fig. 27, B) with the Brunizem, Sharpsburg silt loam, derived from the Wisconsin loess overlying the Yarmouth-Sangamon paleosol. Late Wisconsin slope beveling has stripped the Early Wisconsin loess from the slopes below the level of the paleosol so that the leached and unleached zones of Kansan or Nebraskan till have been subjected to a new cycle of weathering. A Brunizem, Shelby loam, has developed in the leached till or in till that may have been calcareous. A Regosol, Steinauer loam, occurs in the calcareous till. Thus, the lower members of the sequence, Shelby and Steinauer, although occurring in the oldest glacial till region in Iowa are geomorphologically comparable in age to or younger than the Clarion loam developed in the youngest glacial till in Iowa, the Cary. The Shelby and Steinauer have been presumed to be of Wisconsin age (61, p. 81).

On the east slope of cut G (fig. 3) the Regosol, Steinauer loam, occurs in both calcareous Kansan and calcareous Nebraskan tills.

The age relationships of the landscape unit (fig. 27, B) are complex. On level summits of the ridges the Sharpsburg silt loam developed in the upper part of the Iowan-Tazewell loess, and therefore is Tazewell in age. On the shoulders of the slope the Clarinda silt loam or planosolic analogue are Yarmouth-Sangamon. Lower on the slopes the Shelby and Steinauer loams are Cary or Recent. Thus, the ages of the soils on the landscape range from young on the crest, to very old on the shoulders of the slopes, to very young low on the slopes.

Resurrection of the Yarmouth-Sangamon surface by the Late Wisconsin slope bevels has resulted in the incorporation in the modern-landscape continuum of soils that are completely dissimilar in characteristics to those of the other members of the sequence. Of most significance are the decided contrasts in state

²³ Descriptions of all soils discussed within an interrelated geomorphic-landscape unit are listed at end of each section discussion.

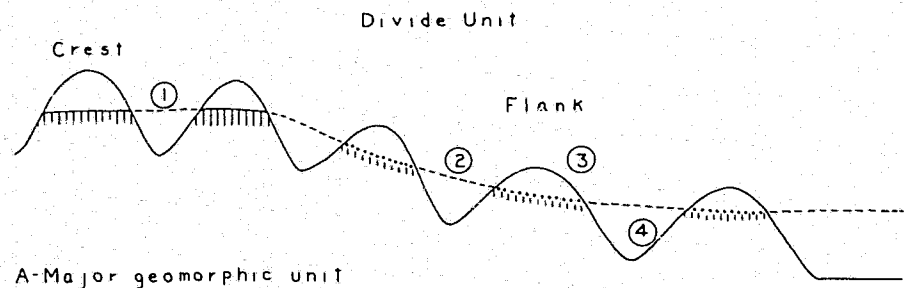

Geomorphic sequence

- ① Yarmouth-Sangamon soil genesis on stable landscape
- ② Late Sangamon pedimentation and soil genesis
- ③ Early Wisconsin dissection, loess deposition and soil genesis
- ④ Late Wisconsin to Recent slope bevelling and soil genesis

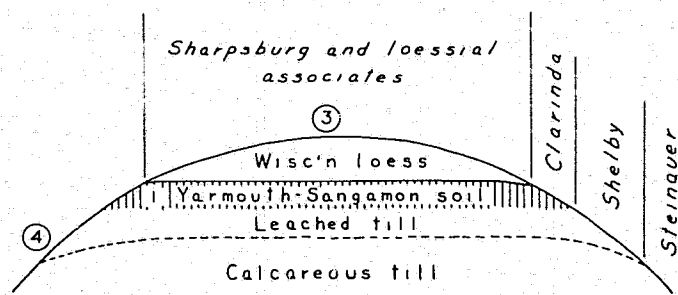

B-Local soil-landscape unit: Divide-unit crest

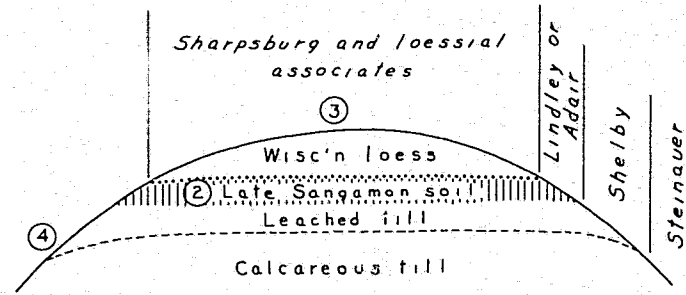

C-Local soil-landscape unit: Divide-unit flank

FIGURE 27.—Diagrammatic relationship of geomorphic units and soil geography in eastern part of traverse.

of weathering, textural development, and permeability properties of the Yarmouth-Sangamon paleosols (fig. 15) in comparison with other members of the sequence.

Thus, the geographic, genetic, and classification characteristics of the Yarmouth-Sangamon and Wisconsin dissection soil-landscape unit are dependent upon complex interrelationships of lithology, topography, and time as well as current and past climatic and vegetational environments of the Pleistocene.

LATE SANGAMON PEDIMENT AND WISCONSIN DISSECTION SOIL LANDSCAPE

Late Sangamon pedimentation and subsequent Wisconsin dissection have resulted in the formation of a second type of soil-landscape unit (fig. 27, A, C). The pedimentation resulted in the stripping of the Yarmouth-Sangamon soil and the genesis of a soil-landscape containing an abundance of weatherable material. The soils on the Late Sangamon pediment are believed to be comparable in morphology to Gray-Brown Podzolic soils and differ distinctly from the Humic Gleys and Planosols of the older landscape (fig. 15, table 18).

Characteristic of the Late Sangamon soils are the reddish brown colors, translocated sediment in the upper part of the profile, the stone line, and the glacial till in the lower part of the profile. Wisconsin dissection of the Late Sangamon surface has isolated individual soil-landscape units. The Late Sangamon pediment and soil occur across ridges as a level to slightly rounded summit buried beneath Farmdale-Iowan-Tazewell loess. On the shoulders of the slopes the Late Sangamon soil has been exhumed by Wisconsin slope beveling that stripped the Early Wisconsin loess from the slopes.

Where the Late Sangamon soil crops out on present slopes, the exhumed paleosol is classified as Adair silt loam or clay loam. The morphological characteristics of the profile of the Adair soils are relict features inherited from the Late Sangamon environment. The stronger chromas and redder hues are not in harmony with the modern environment in which weaker chromas and brown and yellowish brown colors are dominant. The occurrence of the Adair soils in the modern continuum of soils also must be considered a geologic accident. Resurrection of the paleosol has brought it in geographic juxtaposition to soils that are compatible with the modern environment.

On local soil-landscape units the Adair silt loam or clay loam occurs in a sequence with the Brunizem, Sharpsburg silt loam, formed in the upper part of the Farmdale-Iowan-Tazewell loess overlying the Late Sangamon paleosol. Late Wisconsin slope beveling has stripped the Early Wisconsin loess from the slopes below the level of the paleosol so that leached and calcareous Kansan and Nebraskan till have been subjected to a new cycle of weathering. The Brunizem, Shelby loam, formed in the leached till and the Regosol, Steinauer loam, in the calcareous till.

The age relationships of these soil associates also are complex. On the level summit of the local soil-landscape unit the Sharpsburg silt loam of Tazewell age is developed in Early Wisconsin

loess. On the shoulder of the slope the Adair silt loam of Late Sangamon age formed in pedi-sediment, stone line, and leached Kansan or Nebraskan till. Progressively downslope the Shelby loam of Late Wisconsin or Recent age formed in leached till and the Steinauer loam of comparable age in calcareous till.

SOILS OF THE SOIL-LANDSCAPE UNITS

Adair silt loam or clay loam is a dark colored, slowly permeable soil formed in pedi-sediment overlying pre-Wisconsin till and now exposed on shoulders of slopes below the Wisconsin loess. The surface soil is a dark brown gritty silt loam. The subsoil is a strong brown or reddish brown gritty clay loam or gritty clay. A thin layer of gravel (stone line) occurs in the upper part of the B horizon. Carbonates occur at depths of more than 5 feet. Often the profile is truncated so that the reddish-colored B horizon is exposed on the modern surface. The Adair soil is the outcropping of the paleosol of the Late Sangamon pediment.

Clarinda silt loam has a surface layer up to 7 inches thick, which is a friable silt loam. It appears black when wet and dark brown when dry. The subsurface layer, from 7 to 13 inches, is a very dark gray silty clay loam. Below 13 inches the subsoil is an olive gray silty clay or clay (gumbotil). It is very plastic and sticky when wet and extremely hard when dry. Water moves very slowly through the subsoil. Weatherable minerals are sparse throughout the solum. The Clarinda is the cropping out of the Yarmouth-Sangamon paleosols on the modern surface.

Sharpsburg silt loam is a dark, medium textured, moderately to moderately slowly permeable soil formed from loess under grass. The Sharpsburg is intermediate between Marshall and Grundy soils in physical and chemical properties. Clay content of the B horizon ranges from 36 to 42 percent, in contrast to 27 to 35 percent for Marshall and 42 to 50 percent for Grundy. The Sharpsburg is moderately well drained and has slopes ranging from 2 to 12 percent. It occurs in association with the Shelby, Clarinda, Lagonda, and Adair soils. The Sharpsburg silt loam formed in loess of Tazewell age, and where it is uneroded on uplands is of Tazewell age.

Shelby loam is a dark, medium-textured, moderately permeable soil formed under grass from fine textured loam to clay loam till of pre-Wisconsin age. These soils have brown to yellowish brown B horizons. Carbonates usually occur at depths of 25 to 45 inches. The slope range of the Shelby is 12 to 30 percent, and it occurs in association with the Clarinda, Adair, and Steinauer soils. The Shelby loam occurs on slopes that are of Late Wisconsin-Recent age.

Steinauer loam is a moderately dark colored, medium textured, moderately slowly permeable soil formed under grass from pre-Wisconsin till. It occurs on slopes of 17 to 30 percent and is a Regosol with carbonate present at or near the surface. The Steinauer occurs in association with the Clarinda, Shelby, and Adair soils. The Steinauer soils occur on slopes that are the result of Late Wisconsin-Recent dissection.

*Sangamon Surface, Late Sangamon Pediment,
and Wisconsin Dissection*

SANGAMON SURFACE AND WISCONSIN DISSECTION
SOIL LANDSCAPE

Along the western part of the traverse in the area of occurrence of Loveland loess, the old stable landscape on the upper flanks and crests of divide units is Sangamon in age. As has been shown, the soils of the Sangamon surface developed in Loveland loess increase in degree of morphological development from west to east along the traverse (figs. 16, 17). The Sangamon paleosols have been exposed by dissection of Early Wisconsin time and Late Wisconsin to Recent (fig. 28A, B).

Where the Sangamon paleosols or Loveland loess crop out on the modern surface, the surficial soil is classified as the Malvern silt loam. The Malvern soil series is not well defined. It has been described as developed in Loveland loess (42, pp. 21, 23), or as the outcropping of the paleosols developed in Loveland loess (2, p. 7). The differences in the properties of the Sangamon paleosols along the traverse (figs. 16, 17) as well as the differences in the Loveland loessial parent material (fig. 9) show that the regional characteristics of the Malvern silt loam may have a wide range, as the series is presently defined. If the outcrops of the Sangamon paleosols are classified as the Malvern, the textures of the B horizons may range from 32 to 55 percent clay (fig. 17). The classification problem may warrant further study as more refined soil surveys are undertaken in southwestern Iowa.

In the local soil-landscape unit where the Sangamon surface has been dissected by a Wisconsin surface, a sequence of the Monona or Marshall silt loams and their associated soils occurs in Wisconsin loess on the summits and shoulders of a ridge. The Malvern silt loam near the middle of the slope is where the Sangamon paleosols crop out. As presently defined, the Malvern silt loam also occurs lower on the slope where the parent Loveland loess is exposed. A paleosol of the Yarmouth interglacial age developed in Kansan till (fig. 6) may occur on the slope below the Loveland loess. Such a soil may be Lagonda loam or Clarinda silt loam depending on the morphology of the profile. Deep dissection may permit occurrence of the Shelby and Steinauer low on the slope.

The age relationships may be very complex: from young soil on the summit of Tazewell age, to old soil on the slope of Sangamon age, to older soil lower on the slope of Yarmouth age, to youngest soils lowest on the slope of Late Wisconsin age. In most places, however, colluvial sediment has covered the lower members of the association so that the complete sequence is not exposed (fig. 29).

LATE SANGAMON PEDIMENT AND WISCONSIN DISSECTION
SOIL LANDSCAPE

The Late Sangamon pediment below the Sangamon upland has been dissected also by slope bevels of Wisconsin age (fig. 28A, C).

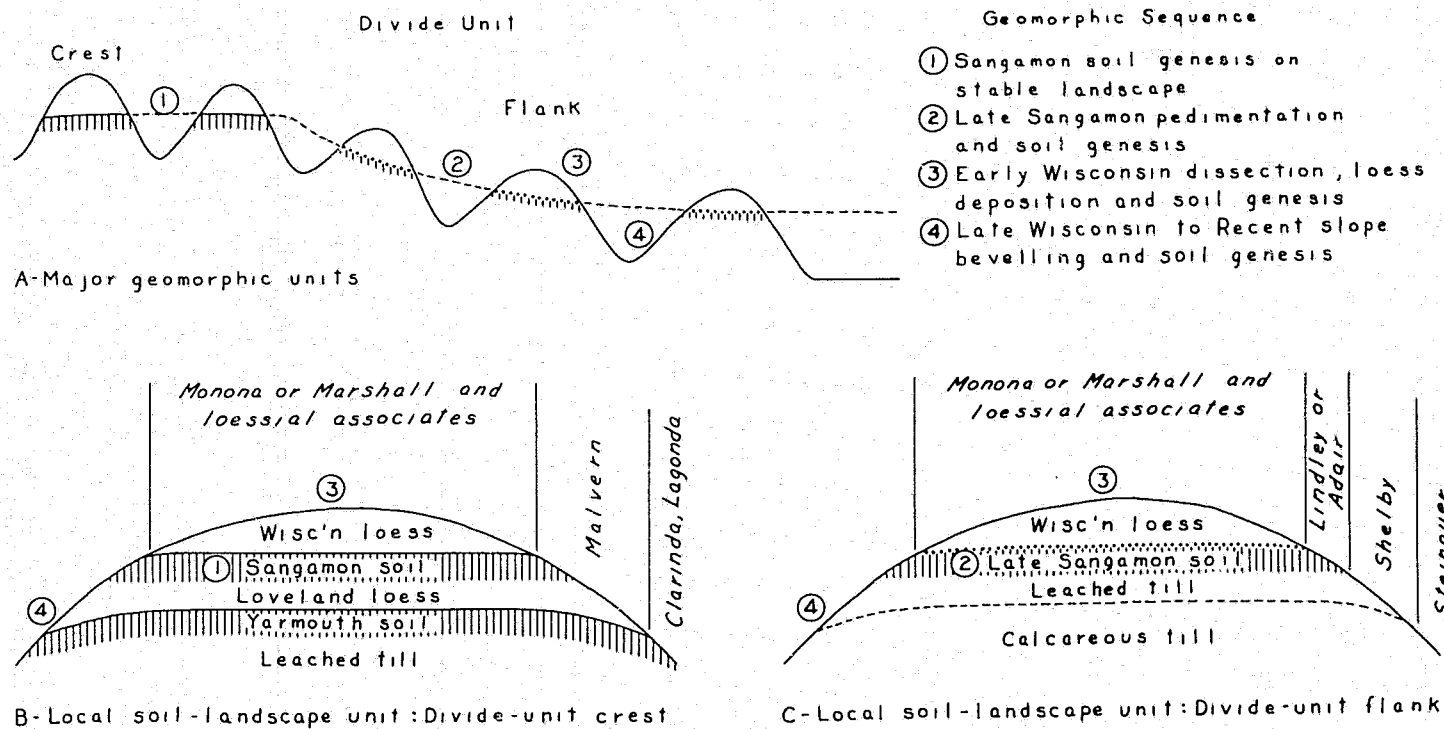

FIGURE 28.—Diagrammatic relationship of geomorphic units and soil geography in western part of traverse.

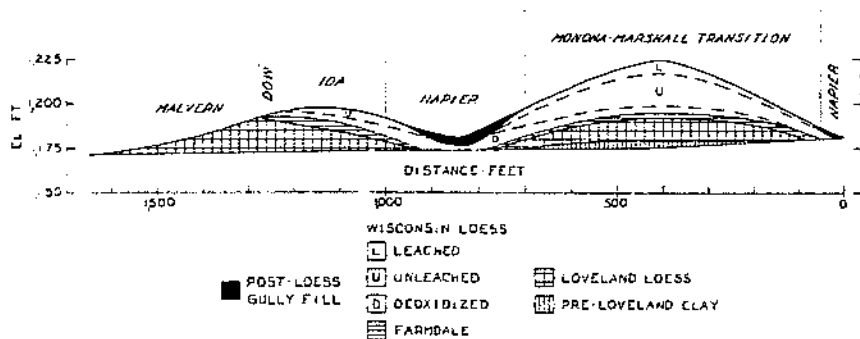

FIGURE 29.—Relationship of soils and Pleistocene stratigraphy, cut 36.

Where the Loveland loess has been stripped and the pediment developed on till (fig. 19), local soil-landscapes occur that are comparable to those of the eastern part of the traverse. The units differ in that the soils on the summits of the Wisconsin loess are the Monona and Marshall silt loams and their loessial associates rather than the Sharpsburg silt loam.

The Yarmouth clay and its surficial paleosols may crop out on slopes of local soil-landscape units. Because the clay has not been recognized previously, soils derived from it have not been established at present but may need to be in the future.

SOILS OF THE SOIL-LANDSCAPE UNITS

Lagonda loam is a soil with a dark colored surface 10 to 12 inches thick. The B horizon is a mottled dark gray to dark grayish brown, plastic, heavy clay loam that is very slowly permeable. The C horizon is a mottled, yellowish brown, medium plastic, light clay loam. The Lagonda soils formed in Kansan or Nebraskan till. They usually occur on slopes of 7 to 10 percent and are the outcropping of paleosols that are pre-Late Sangamon.

Malvern silt loam is a dark colored, medium textured, slowly permeable soil developed in Loveland loess that crops out on slopes in the Monona and Marshall soil association areas. The Malvern generally occurs in the middle of slopes that range from 7 to 15 percent. Where the Sangamon paleosols crop out, the reddish brown B horizon may range from a light silty clay to heavy silty clay. The textures of the Loveland loess parent material increase in clay content in an easterly direction.

Marshall silt loam is a dark colored, medium textured, moderately permeable, well-drained soil formed in thick loess of Tazewell age. It is characterized by a dark brown surface and well-developed granular structure. The Marshall occurs on rolling topography on slopes that range from 2 to 12 percent. It has greater B horizon development (30 to 35 percent clay) than the Monona silt loam and less B horizon development than the Sharpsburg silt loam.

Monona silt loam is a moderately dark colored, medium textured soil of moderately rapid permeability. It is a weak brown

silt loam and shows no clay accumulation in the B horizon. Clay content of the subsoil ranges from 20 to 27 percent. The Monona silt loam differs from the Marshall by its somewhat lighter colored surface and lack of a distinct textural B horizon. The Monona soils occur on slopes from 5 to 15 percent and are derived from Wisconsin loess of Tazewell age.

Wisconsin Surfaces

TAZEWELL UPLANDS

Landscapes of the soils derived from Wisconsin loess along the traverse can be assigned to two major categories: (1) a surface of deposition but slightly modified by subsequent erosion, and (2) a surface of erosion. The upper part of the loess has been shown to be of Tazewell age (fig. 11) although the whole of loess deposition encompassed the Farmdale, Iowan, and Tazewell. Soils formed on the uneroded summits of ridges capped by Wisconsin loess must be of Tazewell age. Slopes that bevel the loess must be younger than the loess or Late Wisconsin to Recent in age. The Late Wisconsin dissection and the gully cut and fill surface conform to the post-Tazewell erosion cycles.

Characteristics of the soils, Monona, Marshall, and Sharpsburg silt loams, that formed on the uneroded summits of the Wisconsin loess have been described (21, 22). The increase in intensity of morphological development from the Monona to the Sharpsburg has been illustrated (fig. 18). The question has been raised whether the age factor in itself is the cause of the differences in morphologies of soils as concluded by Hutton (22, pp. 321-323). In the previous study the soils were considered to be in temporary equilibrium with the environment. All the soils are Brunizems developed under grass.

Recently data have been accumulated during the course of radiocarbon studies that indicate changes in the climatic and vegetational environments of Iowa. Such environmental changes undoubtedly affected the soil-landscapes of the Monona, Marshall, and Sharpsburg silt loams.

Wood samples (hemlock and spruce) from the earliest Wisconsin glacial drift in northeastern Iowa have been dated $>29,000$ to $>35,000$ years old. A wood sample (larch) from the A horizon of the Regosol in the Farmdale loess in cut 33 (pl. I) was dated at $24,500 \pm 800$ years (table 19). This value is in excellent agreement with the type Farmdale in Illinois that has been dated at $22,900 \pm 900$ to $25,100 \pm 800$ years (68, p. 470).

Near Des Moines (Mitchellville) and Ames (Clear Creek), Iowa, wood (hemlock, spruce, and yew) taken from within the Tazewell loess has been dated at $16,720 \pm 400$ to $16,720 \pm 500$ years. Wood samples (fir, hemlock, larch, and spruce) collected just below the base of Cary till near Jefferson (Scranton No. 1, No. 2) and Ames (Cook Quarry) were dated at $13,820 \pm 400$ to $14,470 \pm 400$ years. Wood (hemlock) samples collected from Cary till and outwash near Ames (Cook Quarry) and Fort Dodge (Lizard Creek) are $11,952 \pm 500$ to $13,300 \pm 900$ years old.

TABLE 19.—Radiocarbon dates in Iowa

Substage and sample No. ¹	Date ²	Location	Vegetation
Postglacial: W-701.....	<250	Thompson Creek, Harrison County.	Box elder.
W-799.....	1,100±170	do.....	Walnut.
I-295.....	1,740±110	Effigy Mounds, Allamakee County.	Charcoal.
W-699.....	1,800±200	Thompson Creek, Harrison County.	Willow.
W-702.....	2,020±200	do.....	Red elm.
W-551.....	6,570±200	McCulloch peat bog, Hancock County.	Grass. ³
W-554.....	6,580±200	do.....	Do.
W-235.....	6,800±300	Middle Silver Creek, Pottawattamie County.	Grass (?)
W-549.....	8,170±200	McCulloch peat bog, Hancock County.	Oak. ³
W-553.....	8,110±200	do.....	Do.
W-700.....	11,120±440	Thompson Creek, Harrison County.	Spruce.
W-882.....	11,600±200	Willow Drainage Ditch, Harrison County.	Spruce.
W-548.....	11,660±250	McCulloch peat bog, Hancock County.	Hemlock.
W-552.....	11,790±250	do.....	Do.
Cary: C-596.....	11,952±500	Cook Quarry, Story County.	Hemlock.
C-563.....	12,200±500	do.....	Do.
C-912.....	12,120±530	Lizard Creek, Webster County.	Hemlock.
C-913.....	13,300±900	do.....	Do.
W-626.....	12,970±250	Britt, Hancock County.....	Larch.
W-625.....	13,030±250	do.....	Do.
Tazewell-Cary: W-517.....	13,910±400	Seranton No. 2, Greene County.	Spruce.
C-664.....	14,042±1,000	Cook Quarry, Story County.	Hemlock.
W-513.....	13,820±400	Seranton No. 1, Greene County.	Fir, hemlock, larch, spruce.
W-512.....	14,470±400	do.....	Do.
W-881.....	14,300±250	Willow Drainage Ditch, Harrison County.	Spruce.
Tazewell: W-153.....	14,700±400	Clear Creek, Story County.	Hemlock.
C-528.....	16,367±1,000	do.....	Do.
W-126.....	16,720±500	Mitchellville, Polk County.	Yew, spruce, hemlock.
C-481.....	>17,000	do.....	Do.
W-879.....	19,050±300	Logan, Harrison County.	Spruce.
Farmdale: W-141.....	24,500±800	Hancock, Pottawattamie County.	Larch.
Iowan: W-503.....	>29,000	Fayette, Fayette County.	Hemlock.
W-534.....	>34,000	do.....	Do.
W-514.....	>35,000	Seranton No. 1, Greene County.	Spruce.

TABLE 19.—Radiocarbon dates in Iowa—Continued

Substage and sample No. ¹	Date ²	Location	Vegetation
W-516.....	>35,000	Maynard, Fayette County.	Spruce.
W-880.....	37,600±1,500	Logan, Harrison County.	Spruce.
W-591.....	>37,000	Quimby, Cherokee County.	Larch.
W-599.....	>37,000	Central City, Linn County.	Spruce.
Pre-Iowan:			
W-600.....	>37,000	Independence, Buchanan County.	Hemlock.
W-139.....	>38,000	do.....	Do.

¹ W=U.S. Geological Survey Laboratory, Washington, D.C.; C=University of Chicago Laboratory; I=Isotopes, Inc.

² Radiocarbon years, presumably years before present.

³ Pollen sequence after Lane (1931).

Lane (31) has reported a pollen sequence in a peat bog in north-central Iowa that indicates a systematic vegetational change in later glacial and Recent time. The sequence shows from the base upward: (1) A spruce forest, (2) mixed fir, birch, and spruce, (3) birch with fir and oak, (4) oak with birch and grasses, and (5) grassland vegetation with two intercalated zones of strong semiarid elements. The peat bog on the Des Moines drift-lobe surface at the inner margin of the Altamont moraine must represent late glacial and postglacial conditions.

Lane's pollen zones have been dated by radiocarbon (54). The basal spruce zone is $11,660 \pm 250$ to $11,790 \pm 250$ years old. The zone indicating a transition from coniferous to deciduous forest was $8,110 \pm 200$ to $8,170 \pm 200$ years ago. The zone indicating the beginning of dominance of grass was $6,570 \pm 200$ to $6,580 \pm 200$ years ago.

These evidences (radiocarbon dates and paleofloras) show that during deposition of the Wisconsin loess from which the Monona, Marshall, and Sharpsburg silt loams are derived, there was a coniferous forest cover in parts of Iowa at latitudes as southerly as parts of the Monona, Marshall, and Sharpsburg soil-landscapes. During Cary and a part of postglacial time while the Monona, Marshall, and Sharpsburg were forming, coniferous vegetation existed in Iowa slightly farther north.

Lane (31, p. 171) stated "It would seem . . . that the status of the Iowa prairie as a climax formation would be strengthened since it appears to have developed in place of a former forest as a response to present climatic conditions."

Deevey (14, pp. 271-274) stated that the high-pine pollen Zone B is the best marked and most nearly universal of all features of North American pollen distributions. Zone B normally overlies a spruce-fir zone and underlies the maxima of oak and other deciduous types. Deevey concluded that the pine time of North America according to locality was attained between 9,000 and

6,000 years ago and that it lasted for about 1,000 years. Zones (4) and (5) of Lane's sequence would be younger than the time of pine maxima.

Thus, it would seem that the Monona, Marshall, and Sharpsburg soil landscapes may have had an environment conducive to forest vegetation from the end of loess deposition (14,000 to 15,000 years ago) to 6,000 to 7,000 years ago and one conducive to prairie vegetation since that time.

Climatic changes have also affected the soil landscapes. The Cary drift sheets in central Iowa attain southerly latitudes comparable to the Monona, Marshall, and Sharpsburg soil landscapes along the traverse. Cary glacier ice occupied the area now marked by their drift sheets. Intensely cold climatic conditions must have been impressed on the adjacent landscapes while the Cary ice was present, that is, from approximately 14,000 to 12,000 years ago. The Monona, Marshall, and Sharpsburg soil landscapes were subjected to these climatic conditions.

Lane (31, p. 169) concluded that his pollen sequence showed a climatic change in post-Mankato time: (1) warming trend that accompanied the change from coniferous to deciduous forest, (2) gradual desiccation of the climate culminating just prior to the dominance of grass, and (3) continuous grassland climate with a second episode of desiccation and return to normal grassland climate. One of these episodes of desiccation may conform to the generally accepted postglacial thermal maximum which probably occurred 4,000 to 5,000 years before present (14, pp. 274-275). However, this episode of desiccation probably is represented in Iowa by Lane's "... climate culminating just prior to the dominance of grass" which is dated at 6,570 radiocarbon years ago.

It seems apparent that the Monona, Marshall, and Sharpsburg soil landscapes have been subjected to temperature regimes that were cold during the later substages of Wisconsin glaciation in Iowa. A cool regime occurred during the postglacial coniferous episode, followed by a warming trend during the deciduous forest regime, and culminated just prior to the dominance of grassland. Transition to the present cooler environment followed.

Paleofloras indicate that the moisture regimes fluctuated. The occurrence of coniferous forest, particularly spruce, fir, hemlock, and larch, are indicative of a more moist regime during the times of Tazewell loess deposition, and during Cary and postglacial times. The occurrence of certain faunal species in the Tazewell loess also indicate a more moist regime (35). The occurrence of the gleyed deoxidized and unleached zone and the intensely mottled zone above the gleyed zone and beneath the sola in the Wisconsin loess, their relationship to faunal zones (fig. 11), and their relationship to Late Wisconsin to Recent slope bevels (fig. 30) are indicative of more humid climatic regimes.

These temperature and moisture fluctuations relative to time have affected the Monona, Marshall, and Sharpsburg landscapes, and undoubtedly have influenced the genetic characteristics of the soils. Factorial changes such as these have not been considered in previous studies of the genesis of these soils (21, 22).

LATE WISCONSIN-RECENT SLOPES

Slope beveling of Late Wisconsin to Recent has resulted in a new cycle of soil genesis that is younger than the age of the crests of the ridges (fig. 30). For example, in cut 42 (52) the Monona

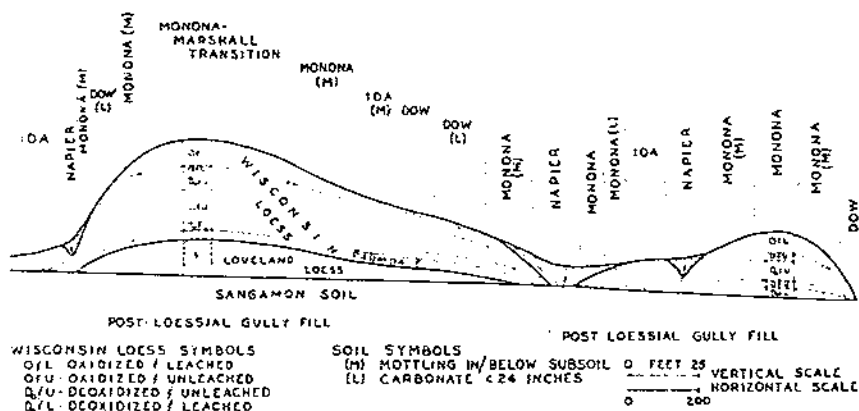

FIGURE 30.—Relationships of soils and Pleistocene stratigraphy, cut 42.

silt loam and a soil transitional between the Monona and Marshall silt loams occur on the rounded summits of the ridges. The Monona and Marshall silt loams are members of the sequence of soils of increasing morphological development related to decreasing thickness of loess (11) and occur on the unmodified or slightly modified depositional surface of the Wisconsin loess. Postloessial erosion should be at a minimum on the ridge crests. Thus, the Monona silt loam and the Monona-Marshall transition should be related genetically to the weathering sequence of the Wisconsin loess.

Below the sola of these soils the oxidized and leached Wisconsin loess has prominent gray mottles. The leached loess grades downward into mottled oxidized and unleached loess. Below an abrupt boundary, the gleyed deoxidized and unleached loess underlies the mottled, oxidized, calcareous loess. The mottled and gleyed zones are indicative of impeded drainage that developed with the impression of a paleo-climatic higher zone of saturation and water table (fig. 11).

Below the Monona-Marshall transition on the west slope of the ridge (fig. 30) the Monona silt loam, Dow silt loam, Napier silt loam, and Ida silt loam occur progressively downslope. Morphologic characteristics of these soils are given in table 20. The Monona is less well developed than the transitional soil on the crest and is mottled both in and below the solum. The Dow silt loam developed in an outcropping of the gleyed deoxidized zone of the loess. Below the Dow is a Monona silt loam in an outcropping of the lower oxidized weathering zone of the loess, but the Monona also is mottled in and below the solum even in this topographic position.

TABLE 20.—Morphological characteristics of soils in cut 42 (pl. 1)

Monona-Marshall	Monona ¹	Ida ¹	Dow	Napier
<p>A₁ 0-12 inches Very dark gray (10YR 3/1) to very dark grayish brown (10YR 3/2), friable, slightly acid, silt loam; moderate fine granular structure.</p>	<p>A₁ 0-5 inches Very dark grayish brown (10YR 3/2), friable, slightly acid, silt loam; moderate fine granular structure.</p>	<p>A₁ 0-5 inches Dark brown (10YR 4/3), very friable, structureless, neutral to calcareous, silt loam.</p>	<p>A₁ 0-7 inches Dark grayish brown (10YR 4/1.5), very friable, neutral, silt loam; medium granular structure.</p>	<p>0-10 inches Black (10YR 2/1), friable, silt loam; moderately weak medium granular structure.</p>
<p>A₃-B₁ 12-16 inches Dark brown (10YR 4/3), friable, slightly acid, silt loam; weak fine subangular blocky structure.</p>	<p>A₃-B₁ 6-14 inches Dark brown (10YR 4/3), friable, slightly acid, silt loam; weak fine subangular blocky structure.</p>	<p>A₃ 5-9 inches Yellowish brown (10YR 5/4), very friable, structureless, silt loam; calcareous with some small lime concretions.</p>	<p>A₃ 7-13 inches Grayish brown (2.5Y 5/2), very friable, calcareous, silt loam; weak coarse subangular blocky structure; many large prominent mottles of reddish yellow (7.5YR 6/8).</p>	<p>10-22 inches Very dark gray (10YR 3/1), friable, silt loam; a few faint dark reddish brown (5YR 3/2) mottles; moderate medium granular structure.</p>
<p>B₂ 16-30 inches Yellowish brown (10YR 5/4), friable, slightly acid, silty clay loam; moderate fine subangular blocky structure.</p>	<p>B₂ 14-24 inches Yellowish brown (10YR 5/4), friable, slightly acid, silt loam; weak fine subangular blocky structure.</p>	<p>C₁ 9+ inches Yellowish brown (10YR 5/4), very friable, structureless, silt loam; calcareous with large numbers of lime concretions.</p>	<p>C₁ 13+ inches Light olive gray (5Y 6/2), friable, massive, calcareous, silt loam; many large prominent mottles of reddish yellow (7.5YR 6/8).</p>	<p>22+ inches Very dark gray (10YR 3/1), friable, silt loam; common faint dark reddish brown (5YR 3/2) mottles; moderate medium granular structure.</p>

B, 30-45 inches
Yellowish brown
(10YR 5/4), friable,
slightly acid, heavy silt
loam; weak fine sub-
angular blocky struc-
ture.

C₁ 45+ inches
Yellowish brown
(10YR 5/4), friable,
massive, neutral, silt
loam.

B₂ 24-40 inches
Yellowish brown
(10YR 5/4), friable,
massive, neutral silt
loam.

C₁ 40+ inches
Yellowish brown
(10YR 5/4), friable,
massive, calcareous,
silt loam; many fine
mottles of light olive
gray (5Y 6/2).

¹ The Monona and Ida soils frequently have many fine mottles of light olive gray (5Y 6/2) in and below the B horizon. Often along with the light olive gray colors are large prominent mottles and root channel fillings of reddish yellow (7.5YR 6/8).

TB 1349 (1967) - USDA TECHNICAL BULLETINS - QUADRA
LANDSCAPE EVOLUTION AND SOIL FORMATION IN SOUTHWESTERN IOWA
RUHE, R. V. DANIELS, R. B. GADY, J. G. 2 OF 4

On the east slope of the west ridge (fig. 30) a similar sequence of soils occurs. Mottling is common in the Monona and Ida silt loams, and the Dow is developed in an outcropping of the gleyed deoxidized zone of the Wisconsin loess.

Thus, on present well-drained topographic positions the soils, Monona, Ida, and Dow, possess mottling and gleying which are characteristic of impeded drainage. These characteristics are not genetically related to the profile development but are relict features of a preexisting environment. Late Wisconsin slope beveling has exhumed parent material on the slope that has characteristics developed under different paleoclimatic conditions. The Monona and Ida have inherited the mottles from the previous weathering of the loess during the environment of higher zone of saturation. Similarly, the Dow in its development has inherited the gleyed horizon from the preexisting soil landscape. Such features in soils may well be considered as geo-pedologic accidents. Mottled zones and gleyed horizons require geomorphic and historical evaluation and in themselves are not infallible criteria indicative of impeded drainage (52).

Post-Late Wisconsin gully cutting and filling has given rise to the development of the Napier silt loam (fig. 30).

Chapter 2

Geomorphology of Parts of the Greenfield Quadrangle, Adair County, Iowa

by Robert V. Rube, *research geologist, Soil Conservation Service*

Introduction

The Greenfield quadrangle is located in Adair County, Iowa, and encompasses the area of T. 75 N. to T. 77 N. and R. 30 W. to the eastern part of R. 32 W. (fig. 31). On the east the quadrangle is bounded by the meridian $94^{\circ}15'$ W. and on the west by $94^{\circ}30'$ W.; on the south by the parallel $41^{\circ}15'$ N. and on the north by $41^{\circ}30'$ N.

Two areas that typify the landscape were selected for detailed study to determine the influence of the geomorphology on the genesis, classification, and geography of the soils of the area: (1) The South Turkey Creek area which includes parts of sections 7, 17, and 18, T. 76 N., R. 31 W., and parts of sections 12 and 13, T. 76 N., R. 32 W.; and (2) the North Turkey Creek area which includes parts of sections 19, 20, 29, and 30, T. 77 N., R. 31 W., and parts of sections 24 and 25, T. 77 N., R. 32 W.

The entire quadrangle includes parts of three drainage basins (fig. 31). Middle River drains the northern part, Grand River the south-central part, and Nodaway River the southwestern part of the area. The Missouri-Mississippi divide crosses Adair County southeasterly from the town of Adair to the north, northeast, and east of the town of Greenfield. In the Greenfield quadrangle it is composed of the divides between the drainage basins of Middle and Nodaway Rivers and Middle and Grand Rivers. Middle River is tributary to the Des Moines River, which drains to the Mississippi River. Nodaway and Grand Rivers are tributaries of the Missouri River. South Turkey and North Turkey Creeks are tributaries of Middle River. The study areas are east of the Missouri-Mississippi divide (fig. 31).

Areal studies were undertaken in the Greenfield quadrangle during 1955-1956 to determine the geographic distributions of the geomorphic surfaces identified in the traverse study from Bentley to Adair, Iowa (fig. 32). The Pleistocene deposits and geomorphic surfaces delineated in the traverse through the town of Adair were easily traced into the Greenfield quadrangle. Then too, a new topographic base map was being completed in the Greenfield quadrangle by the U.S. Geological Survey at the time

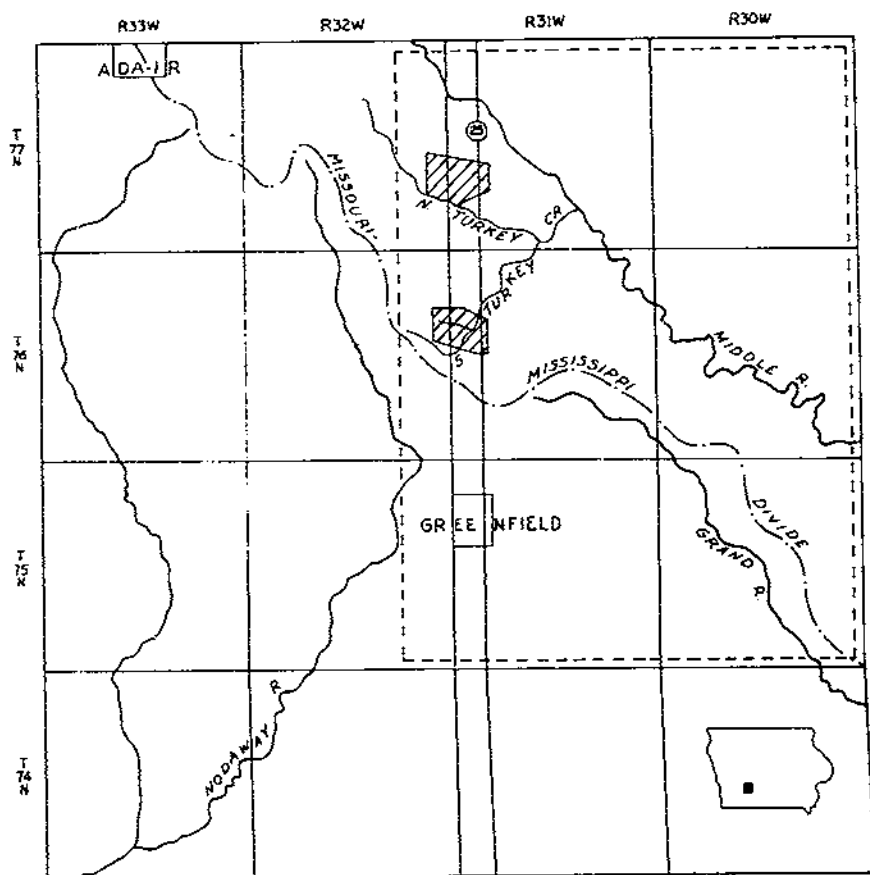

FIGURE 31.—Location of Greenfield quadrangle (bordered by broken line) and North and South Turkey Creek areas (shaded) in Adair County, Iowa.

that the traverse work was being completed. Thus, an excellent base map was available for areal studies.

Pleistocene Deposits

Nebraskan Till

The sequence of two tills identified in the traverse through the town of Adair (pl. II: G, H) also occurs in the Greenfield quadrangle. Along State highway 25 in the South Turkey Creek area, the two tills crop out. In a stream and road cut at the bridge where highway 25 crosses South Turkey Creek (SW $\frac{1}{4}$ sec. 8, T. 76 N., R. 31 W., Adair County) the following section is exposed in the stream cut:

Section A:

Kansan till:

Oxidized and
leached
50 inches

Brown (10YR 5/3) to yellowish brown (10YR 5/4) leached clay loam; subangular and angular blocky; friable; modern soil in upper part.

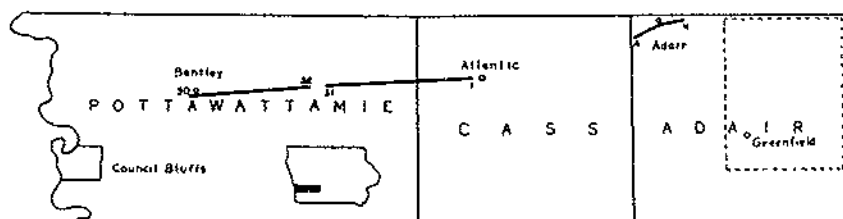

FIGURE 32.—Location of Greenfield quadrangle (bordered by broken line) relative to regional traverse from Bentley to Adair, Iowa.

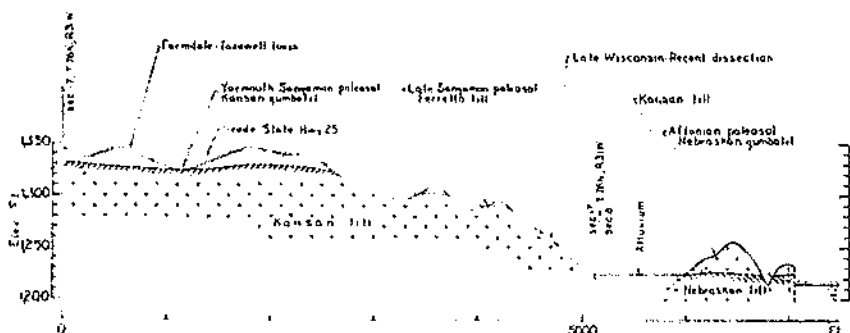

FIGURE 33.—Relationships of Nebraskan till, Nebraskan gumbotil (Aftonian paleosol), Kansan till, and Kansan gumbotil (Yarmouth-Sangamon paleosol) along State highway 25, South Turkey Creek area.

Oxidized and unleached 34 inches	Yellowish brown (10YR 5/8) calcareous clay loam; coarse angular blocky; firm.
Aftonian paleosol: A _b 14 inches	Dark gray (10YR 4/1) leached heavy clay; medium subangular blocky; plastic; clay skins abundant; slightly gritty, but only resistant minerals visible; secondary carbonate concretions common.
B _b 56 inches	Gray (10YR 5/1) leached heavy clay; strong medium subangular blocky; firm but plastic; clay skins abundant; "slickensides" on aggregate faces; gritty but only resistant minerals visible; secondary carbonate concretions in upper part; grades downward to underlying horizon.
C _b 28 inches	Yellowish brown (10YR 5/8) leached clay loam; mottled with gray (10YR 6/1); coarse angular blocky; firm; gritty with weatherable minerals; oxidized and leached Nebraskan till.
Nebraskan till: Oxidized and unleached 136 inches	Brownish yellow (10YR 6/8) calcareous clay loam; mottled with light gray (5Y 7/1); coarse angular blocky; firm; gritty with weatherable minerals, base not exposed.

In the section the horizons A_b to B_b are the Nebraskan gumbotil of Pleistocene-geology terminology (25, pp. 163-171). Kay and Apfel (25, p. 128) recorded the occurrence of many sections of Nebraskan gumbotil in Adair County.

The Nebraskan gumbotil in the stream cut can be traced to the adjacent road cut on the south (fig. 33) where the gumbotil sur-

face is level and is at the base of the cut at the south end. At the center of the road cut a sequence of oxidized and leached Kansan till that is 5 feet 8 inches thick and oxidized and unleached Kansan till that is 27 feet thick overlies the Nebraskan gumbotil.

Kansan Till

The upper till, identified as Kansan in the traverse through the town of Adair (pl. II) was traced into the Greenfield quadrangle. In the South Turkey Creek area along State highway 25, the Kansan till, which overlies the Nebraskan gumbotil in the stream and road cut, is traceable southward across the Recent alluvium of a tributary of South Turkey Creek. In this area the Kansan till is the surficial drift. The landscapes formed in Kansan till overlain by a thin mantle of Wisconsin loess. The surficial drift of the North Turkey Creek area (pl. III) is the same till.

Weathering zones are prominent in the Kansan till (25, p. 219). A surficial soil grades downward into oxidized and leached till, which in turn grades downward into oxidized and unleached till. The latter grades downward into unoxidized and unleached till. The surficial soil may be a paleosol of Yarmouth-Sangamon or Late Sangamon age, or a soil of Wisconsin or Recent age. For example, in the first road cut south of the Recent alluvium along highway 25 in the South Turkey Creek area, the following section is exposed:

Section B:

Tazewell loess:

Oxidized and leached 48 inches	Yellowish brown (10YR 5/6) leached silt loam; massive; friable; modern soil in upper part.
-----------------------------------	--

Farmdale loess:

IA ₁ 12 inches	Dark brown (10YR 4/3) leached silt loam; weak fine platy; disseminated charcoal.
------------------------------	--

Late Sangamon paleosol:

IIA ₂ -B _{1b} 14 inches	Yellowish brown (10YR 5/6) to strong brown (7.5YR 5/6) leached silty clay loam to loam; weak fine subangular blocky; friable to firm; stone line at base; upper part of Late Sangamon paleosol in pediseciment.
--	---

IIIB ₆ 17 inches	Dark brown (7.5YR 4/4) and reddish brown (5YR 4/4) to strong brown (7.5YR 5/6) leached clay loam; strong medium subangular blocky; firm but plastic; gritty; lower part of Late Sangamon paleosol in Kansan till.
--------------------------------	---

Kansan till:

IIIC ₆ Oxidized and leached 62 inches	Yellowish brown (10YR 5/6) leached clay loam; medium angular blocky; friable; pebbles and cobbles of granite, basalt, sandstone, quartzite.
--	---

Oxidized and unleached 154 inches	Yellowish brown (10YR 5/6) calcareous clay loam; coarse angular blocky; firm; pebbles and cobbles of granite, basalt, sandstone, quartzite, limestone, dolomite; carbonate concretions in upper part.
--------------------------------------	---

Unoxidized and unleached 48 inches	Very dark gray (10YR 3/1) calcareous clay loam; coarse angular blocky; firm; pebbles and cobbles similar to those of overlying horizon; base not exposed.
---------------------------------------	---

The unoxidized and unleached till probably most nearly represents the Kansan till deposited by the Kansan glacier. The zones,

oxidized and unleached, oxidized and leached, and surficial soils represent alteration of the original drift by weathering processes. Contacts between weathering zones generally are parallel to the geomorphic surface on the till beneath which the zones have formed. In most cases these surfaces are of pre-Wisconsin age. Angular relationships of younger geomorphic surfaces to the weathering zones in the till may be used to reconstruct the evolution of the younger surfaces.

Wisconsin Loess

The Wisconsin loess in the eastern part of the regional traverse in the vicinity of Adair can be traced directly into the Greenfield quadrangle. The basal increment of the loess is the Farmdale (46, p. 640), which is distinguished from the overlying younger Wisconsin loess by a weak Regosolic buried soil (A-C profile). In most places the Farmdale loess consists entirely of a buried A horizon, 9 to 12 inches thick, that rests upon older buried soils. The Farmdale loess in the South and North Turkey Creek areas occurs only on the upland divides and on the higher summits of the interfluves.

The bulk of the Wisconsin loess is post-Farmdale. The younger loess overlies the buried A horizon of the Farmdale paleo-Regosol.

CHARACTERISTICS

Wisconsin loess blankets completely the upland divides east and west of South Turkey Creek (pl. III). However, along the interfluves between the tributary and side streams of South Turkey Creek, it does not completely cover the landscape. For example, on the summit of the interfluve adjacent to and south of West Branch, is an isolated outlier of loess (pl. III: E.2, 3.8²⁴) separated completely from the mass of loess to the westward (pl. III: D.4, 3.9). It occurs on an intermediate level of a stepped sequence of surfaces common on all of the interfluves in the area.

An outlier of loess on the low level of the landscape (pl. III: D.4, 3.5) also is completely separated from the main mass to the south and west on the upland summit (pl. III: D.4, 3.9).

Areas of loess separated from the main mass also occur on slopes below the interfluve summits regardless of level of the stepped sequence of surfaces, for example, on a slope below the intermediate level and above the alluvium of the modern flood plain (pl. III: E.6, 5.0). There are other similar distributions of loess throughout both South Turkey Creek and North Turkey Creek areas.

Patchy distribution of the loess on the present landscape regardless of topographic position indicates that in the geologic past the loess completely mantled the landscape. Where the loess does not occur on slopes (pl. III: F.7, 4.4), it has been stripped during post-loessial slope erosion. Where the loess does not occur on interfluve

²⁴ Grid coordinates on maps: E.2 is 2/10 of the distance between grid lines E and F; 3.8 is 8/10 of the distance between grid lines 3 and 4.

summits (pl. III: D.7, 3.8 and E.7, 3.8), it has been stripped during the lowering of the interfluvial divide. Such divide lowering is evident particularly (pl. III: D.7, 3.8) where north and south flowing streams have contested a headwater source.

Previous work (47, pp. 665-667) has shown that the thickness and other characteristics of loess vary systematically with distance from an assumed source if the thickness is measured on primary and secondary divide topographic sites. The upland divide west of South Turkey Creek is a primary divide and is part of the Missouri-Mississippi divide in Iowa. On the divide (pl. III: C.2, 4.5) the total thickness of Wisconsin loess is 181 inches, of which the basal 9 inches is Farmdale loess. The post-Farmdale Wisconsin loess is 172 inches thick.

Along the interfluvial summits nearly at right angles to the upland divide in the South Turkey Creek area, the loess thickness varies considerably from the maximum value of the divide (table 21). Measurement sites are located on level to slightly rounded upland summits where post-loessial erosion should be at a minimum. The sequence of sites extends from the divide position on the west eastward down the flank of an individual topographic unit. The loess thickness decreases down the flank of the divide unit. Such loess thickness-topographic site relationships have been reported previously (47, pp. 667-671).

TABLE 21.—*Loess thickness on interfluvial summit south of West Branch*

Site	Location (Pl. III)	Elevation ¹	Farmdale	Post- Farmdale	Total
		<i>Feet</i>	<i>Inches</i>	<i>Inches</i>	<i>Inches</i>
Divide.....	C. 20, 4.50	1,340	9	172	181
Interfluvial.....	C. 70, 3.85	1,333	6	150	156
Interfluvial.....	D. 35, 3.95	1,330	12	114	126
Interfluvial.....	E. 15, 3.85	1,326	6	122	128

¹ Elevation of basal surface on which loess was deposited.

The textural characteristics of the loess in the South Turkey Creek area conform to the regional variation with relation to a distant source. The loess is finer textured than that along the regional traverse in Pottawattamie and Cass Counties, Iowa. In the loess in cut 50 of the traverse, 61 miles west, there is 62 percent coarse silt,²⁵ 22 percent fine silt, and 16 percent clay. In cut 11, 36 miles west, these size fractions are 44, 30, and 26 percent. On the west divide of the South Turkey Creek area they are 37, 34, and 29 percent. Thus, from west to east the coarse silt fraction progressively decreases in abundance and the fine silt and clay progressively increases.

The Monona silt loam is the soil in the loess in cut 50; the Marshall silt loam is the soil in the loess in cut 11; the Sharpsburg

²⁵ Coarse silt is 0.62-0.016 m.m., fine silt 0.016-0.002 m.m., and clay <0.002 m.m.

silty clay loam occurs in the uppermost part of the loess at the South Turkey Creek site. Hutton (21, p. 426) previously described the textural variations of the loessial parent materials of the three soils. The data in this report are in accord with the data of Hutton.

WEATHERING ZONATION

Along the traverse between Bentley and Atlantic weathering zones in the post-Farmdale Wisconsin loess occur in regional distribution (47, p. 640). The general zonation, from the modern surface downward, is:

- O & L zone: oxidized and leached yellowish brown silt loam loess with iron oxide diffuse throughout the matrix.
- Do & U zone: deoxidized and unleached gray silt loam loess with iron oxide segregated in reddish brown pipestems (tubules) and concretions in a gray matrix.
- O & U zone: oxidized and unleached yellowish brown silt loam loess with iron oxide diffuse throughout the matrix.
- Do & L zone: deoxidized and leached gray silt loam loess with iron oxide segregated in reddish brown pipestems (tubules) and concretions in a gray matrix.

The lower deoxidized and leached zone overlies the buried A horizon of the paleo-Regosol in Farmdale loess.

Two faunal zones, independent of the stratigraphic zonation of the weathered zones (53, pp. 271-272), also occur in the loess.

To the eastward along the traverse the two deoxidized zones coalesce so that the general sequence in the loess is an oxidized zone grading downward into a deoxidized zone, which in turn overlies the Farmdale loess (53, p. 271, fig. 36). Such zones occur from a few miles west of Atlantic and eastward through the part of the traverse in the vicinity of Adair (fig. 32) where the general weathering zonation, from the surface downward, is:

- O & L zone: modern solum at the surface grading downward into oxidized and leached yellowish brown silty clay loam loess commonly mottled with gray; gray mottles increase with depth; and grades into a gray silty clay loam loess with yellowish brown and brown mottles.
- Do & L zone: deoxidized and leached gray silty clay loam loess with iron oxide segregated in reddish brown pipestems (tubules) and concretions; a reddish brown iron oxide band commonly occurs at the top of this zone.

The deoxidized and leached zone overlies the buried A horizon of the paleo-Regosol in Farmdale loess.

This kind of weathering zonation in post-Farmdale Wisconsin loess occurs in regional distribution throughout the Greenfield quadrangle but is generally restricted to the upland divide and the intermediate level of the stepped sequence of surfaces along

interfluves. For example, on the upland divide west of South Turkey Creek, the following section occurs:

Section C:

Solum-Sharpsburg silty clay loam:

A_{1P} 0-6 inches Black (10YR 2/1) light silty clay loam; massive; friable; leached; abrupt to A₁₂.

A₁₂ 6-15 inches Black (10YR 2/1) light silty clay loam; weak to moderate granular; friable; leached; gradual to A_{3B}₁.

A_{3B}₁ 15-18 inches Black (10YR 2/1.5) and very dark grayish brown silty clay loam; weak to moderate subangular blocky; friable; leached; gradual to B₂₁.

B₂₁ 18-21 inches Dark grayish brown (10YR 4/2) and very dark gray (10YR 3/1.5) medium to heavy silty clay loam; moderate fine subangular blocky; friable; leached; thin discontinuous clay skins; gradual to B₂₂.

B₂₂ 21-28 inches Dark grayish brown (10YR 4/2) heavy silty clay loam; weak medium subangular blocky; friable; leached; thin discontinuous clay skins; gradual to B₃.

B₃ 28-43 inches Dark grayish brown (10YR 4/2.5) silty clay loam; sparsely mottled with yellowish brown (10YR 5/4); weak medium blocky; friable; leached; thin discontinuous clay skins; gradual to C₁.

Tazewell loess:

C₁ 43-66 inches Dark grayish brown (10YR 4/2.5) light silty clay loam loess; commonly mottled with grayish brown (2.5Y 5/2); moderate coarse prismatic; friable; leached; gradual to underlying zone.

O & L 66-104 inches Yellowish brown (10YR 5/4) loess; abundantly mottled with gray (10YR 5.5/1); massive; friable; leached; gradual to underlying zone.

O & L 104-144 inches Gray (10YR 5/1) loess; abundantly mottled with yellowish brown (10YR 5/4); massive; friable; leached; distinct boundary at base.

D₀ & L 144-172 inches Gray (10YR 5/1) loess with yellowish red (5YR 5/6) pipestems and concretions; massive; friable; leached; overlies A horizon of buried paleo-Regosol in Farmdale loess.

The weathering zones in the loess are distinct and readily discernible (fig. 34). The contacts between zones parallel in general the basal surface on which the loess was deposited. In places modern slopes angularly bevel the weathering zones in the loess.

FAUNA

In most places the Wisconsin loess in the South and North Turkey Creek areas is leached of carbonates. Therefore the calcareous shells of the gastropod fauna, which are characteristic of the loess, have been destroyed during weathering. An exposure of calcareous loess occurs in a road cut, however, a quarter of a mile north of the northwest corner of the Greenfield quadrangle in the SE $\frac{1}{4}$ sec. 36, T. 78 N., R. 32 W., Guthrie County, Iowa. The calcareous loess is fossiliferous and contains a fauna that is characteristic of the Wisconsin loess along the regional traverse from Bentley to Adair (tables 22 and 12).

According to the faunal zones of Leonard (34, p. 10-18) the species of the loess are indicative of the Tazewell. Therefore, the loess should be of Tazewell age. This dating of the post-Farmdale loess in the Greenfield quadrangle is in good agreement with the determination of the age of the loess along the regional traverse.

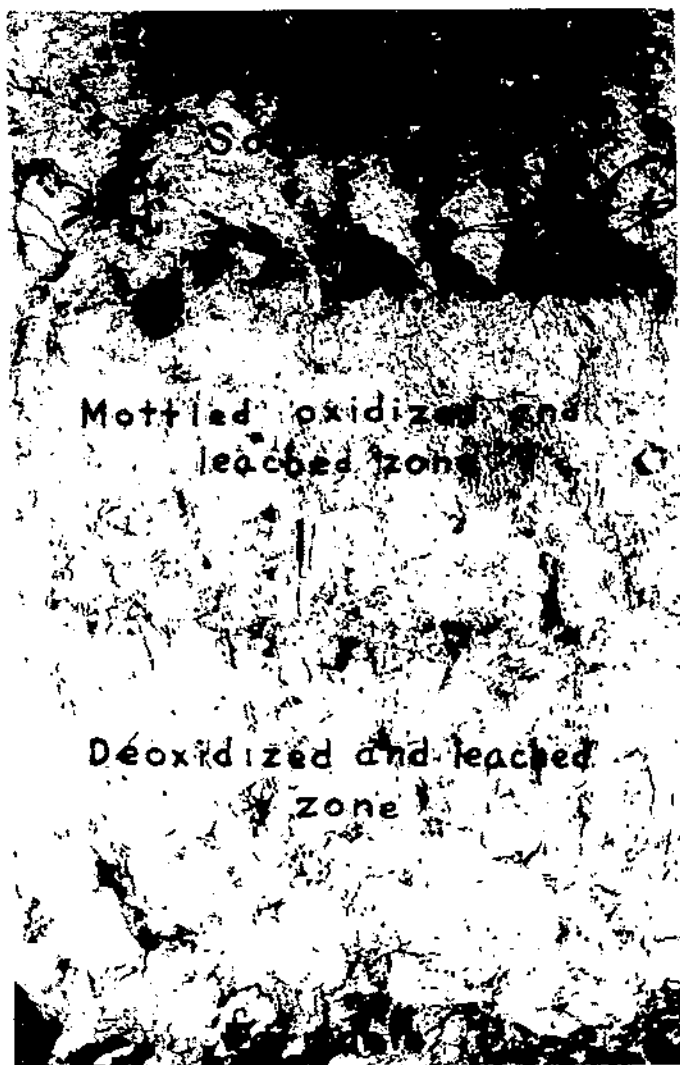

FIGURE 34.—Weathering zones in post-Farmdale Wisconsin loess.

Geomorphic Surfaces

Landscape

The modern surface in the South and North Turkey Creek areas does not slope continuously from the divides to the major drainages. Slopes along the axes of interfluves are broken at two or three places by distinct changes in gradient. For example, in the South Turkey Creek area (fig. 35) each interfluve has a sequence of stepped levels that rises from the valley shoulders to the upland divide. Along the profile from A to B (fig. 36) a low level

TABLE 22.—Fauna of the Wisconsin loess of Greenfield quadrangle¹

Species	Iowan	Transition	Tazewell
<i>Columella alticola</i>			X
<i>Retinella electrina</i>			X
<i>Succinea ovalis</i>			X
<i>Succinea grosvenori</i>		X	X
<i>Vertigo modesta</i>		X	X
<i>Deroceas laeve</i>	X	X	X
<i>Hawajia minuscula</i>	X	X	X
<i>Pupilla blandi</i>	X	X	X
<i>Pupilla muscorum</i>	X	X	X
<i>Succinea ayura</i>	X	X	

¹ After Leonard (34).

is separable from an intermediate level which, in turn, is separable from the high level of the upland. Along the profile from A to P an intermediate level occurs between the modern flood plain and the upland divide. This sequence of levels is the result of multicyclic erosion of a glacial till landscape. It is further complicated by the mantling of the glacial-till landscape by loess. In the field the multileveled landscape is easily discernible (fig. 37).

The high level, mantled by Farmdale-Tazewell loess, is controlled by the Yarmouth-Sangamon surface (pl. II). This surface is essentially a weathered relict of the Kansan-drift plain that has not been modified profoundly by erosion since Kansan till. The surface is characterized by deep, intensively weathered paleosols that in most places remain buried.

The intermediate level, in most places mantled by Farmdale-Tazewell loess, is the Late Sangamon erosion surface that was cut into Kansan till below the level of the Yarmouth-Sangamon surface. The Late Sangamon surface, in directions toward the upland divide, rises gradually and then more sharply up a concave back-slope to the level of the Yarmouth-Sangamon surface (fig. 36). The younger erosion surface is characterized by a lag-gravel erosion pavement (stone line) on Kansan till, which is overlain by finer textured transported sediment derived from the till. A paleosol, somewhat lesser developed than that of the Yarmouth-Sangamon surface, occurs in the sediment, stone line, and uppermost part of the Kansan till.

The low level of the landscape is the Early Wisconsin erosion surface that is cut into Kansan till below the Late Sangamon surface (fig. 36). At some places the Early Wisconsin surface is mantled by Tazewell loess, but no paleosol separates the till from the loess.

The complex of surfaces has been subjected to erosion and sedimentation in Late Wisconsin-Recent time. All of the surfaces, Yarmouth-Sangamon, Late Sangamon, and Early Wisconsin, are dissected and now occur on upland divides or on interfluves.

Loess was deposited on the level upland divides and interfluvial summits. The constructional surface of the loess dates from the

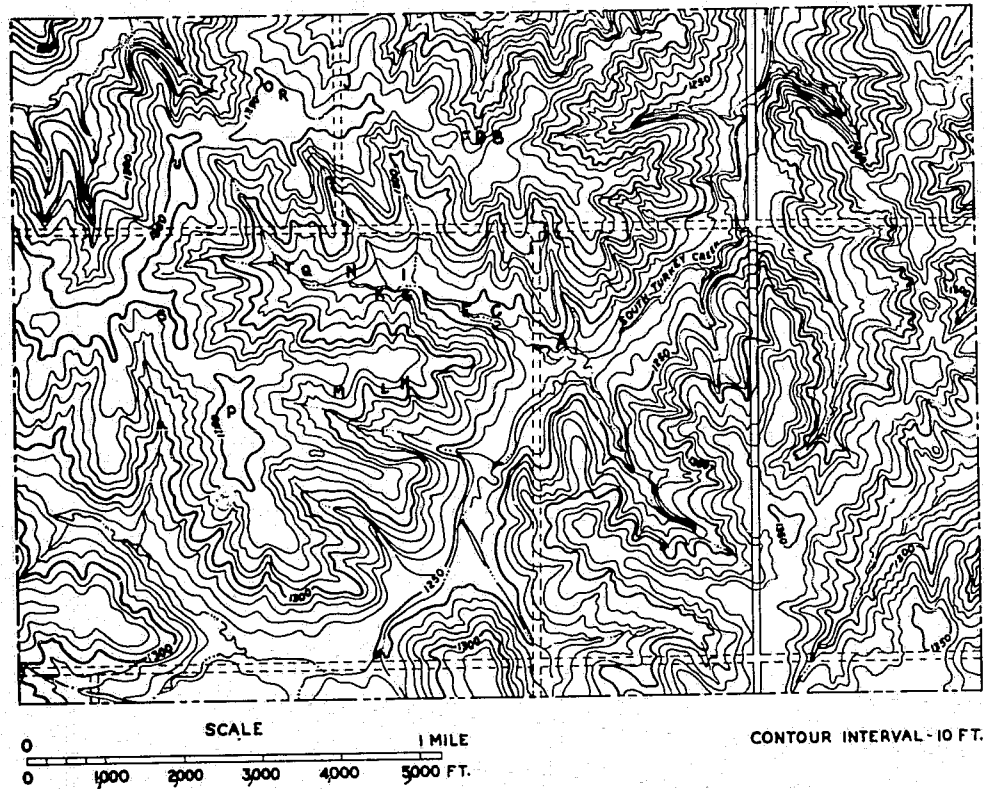

FIGURE 35.—Topographic map of South Turkey Creek area. A-B . . . S-T-U, see fig. 36.

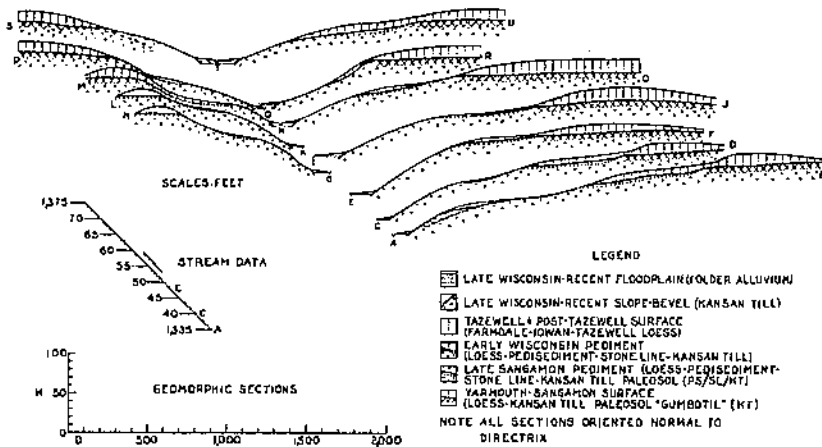

FIGURE 36.—Geomorphic profile sections of interfluves peripheral to West Branch, a tributary of South Turkey Creek (pl. II). For locations of sections, see fig. 35.

end of loess deposition and is of Tazewell age. Late Wisconsin-Recent slopes have also beveled the Tazewell loess.

The slopes descend to alluvial fills that occupy topographic positions lower on the slopes or at the bases of the slopes. The alluvial fills are believed to be contemporary of the post-Tazewell gully-fill cycle in southwestern Iowa. The basal fill of this alluvial cycle has been dated at $6,800 \pm 300$ radiocarbon years. Hence the majority of the slopes in the areas must be of Recent age.

Yarmouth-Sangamon Surface

The Yarmouth-Sangamon surface underlies the Farmdale-Tazewell loess on the upland divides east and west of South Turkey Creek, and is the upland peripheral to West Branch in the South Turkey Creek area (pl. II). In the North Turkey Creek area (pl. IV) the Yarmouth-Sangamon surface mantled by Farmdale-Tazewell loess is the upland divide north of North Turkey Creek and the upland surface peripheral to North Branch of North Turkey Creek. In both of these areas the high level of the landscape is controlled by the relict Yarmouth-Sangamon surface. The old surface conforms to the topographic position comparable to the position of the surface along the regional traverse at Adair.

In the South Turkey Creek area the Yarmouth-Sangamon upland west of South Turkey Creek is a part of the Missouri-Mississippi divide, which is the major watershed in Iowa.

PALEOSOLS

The Yarmouth-Sangamon surface is an undulating, swell and swale surface that has a local relief of 5 to 10 feet and that is

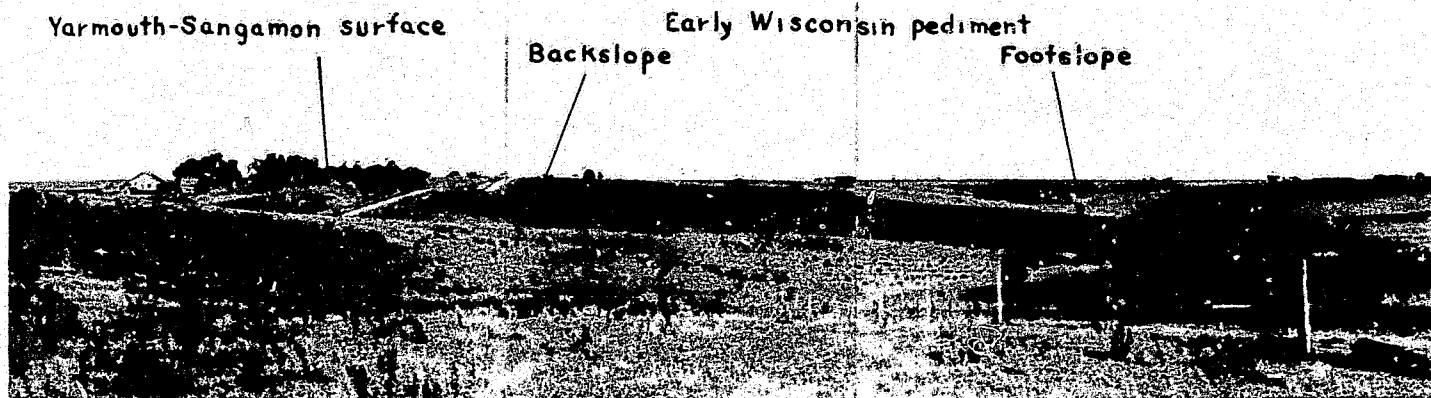

FIGURE 37.—Stepped sequence of topographic levels along interfluvium in South Turkey Creek area. Note nearly level Early Wisconsin pediment footslope and concave backslope that rises to Yarmouth-Sangamon surface. Landscape loess-mantled.

characterized by distinctive, deep, intensively weathered paleosols. On the surface distances between crests of swells across intervening swales are about an eighth of a mile. Thus, on the surface variable soil-moisture conditions existed (48, p. 445-450). Aeration and soil drainage were better on the swells than in the swales of the landscape.

A buried Yarmouth-Sangamon paleosol on the crest of a swell in the North Turkey Creek area has the following morphology:

Section D (pl. IV: H.6, 4.0):

0-153 inches	Tazewell loess with modern soil in upper part.
IA _{1b} 153-167 inches	Dark grayish brown (10YR 4/2) silt loam with yellowish red (5YR 4/6-5/6) iron oxide concretions and pipestems; weak fine to medium platy; friable; leached Farmdale loess.
IIA _{2bx} 167-177 inches	Gray (10YR 5/1) silty clay loam with yellowish red (5YR 5/6) iron oxide stain on aggregate faces; fine subangular blocky; clay skins lacking; friable; gritty but no weatherable mineral fragments visible; leached upper horizon of Yarmouth-Sangamon paleosolum in Kansan till.
IIB _{1wb} 177-182 inches	Gray (10YR 5/1) heavier silty clay loam; yellowish red (5YR 4/6) and red (2.5YR 4/6) iron oxide stain on aggregate faces; moderate medium subangular blocky; clay skins moderately abundant; moderately plastic; gritty but only resistant minerals visible; leached.
IIB _{21wb} 182-192 inches	Gray (10YR 4/1) clay; yellowish red and red iron oxide stain on aggregate faces; strong medium subangular blocky; clay skins cover aggregate faces; plastic; gritty with only resistant minerals visible; leached.
IIB _{22wb} 192-203 inches	Dark gray (10YR 4/1) clay; brown (7.5YR 4/4) and reddish brown (5YR 4/4) iron oxide stain on aggregate faces; strong medium subangular blocky; clay skins cover aggregate faces; plastic; gritty with resistant minerals visible; leached.
IIB _{3wb} 203-221 inches	Gray (5Y 6/1) heavy clay loam; mottled with strong brown (7.5YR 5/8); moderate medium subangular blocky; clay skins on aggregate faces in upper part of horizon, channelized vertically in tubules in lower part; increasingly gritty in lower part with weatherable minerals visible; leached lower horizon of Yarmouth-Sangamon paleosolum in Kansan till.
IIC _{1b} 221+ inches	Strong brown (7.5YR 5/8) clay loam; mottled with gray (5Y 6/1); coarse angular blocky; prominent clay skins channelized along vertical tubules; very gritty with weatherable minerals visible; oxidized and leached Kansan till.

This paleosol is comparable morphologically to modern Planosols (48, p. 446). A leached light-textured A_{2b} horizon with a clay content of 32 percent overlies a thin B_{1b} (5 inches thick) that is sharply delineated from an underlying B_{2b} horizon with a clay content of 58 percent (fig. 38, D). The part of the solum B_{1cb}-B_{3pb} is the "gumbotil" of Pleistocene-geology terminology. The paleosol is easily identifiable in road cuts and in outcrops on Recent slopes (fig. 39).

A second kind of paleosol also occurs on the better aerated parts of the Yarmouth-Sangamon surface. A buried soil on the crest of a swell in the South Turkey Creek area has the following morphology:

Section E (pl. II: D.5, 1.5):

0-51 inches	Tazewell loess with modern soil in upper part.
IA _{1b} 51-62 inches	Dark grayish brown (10YR 4/2) silt loam; weak medium platy; friable; leached Farmdale loess.

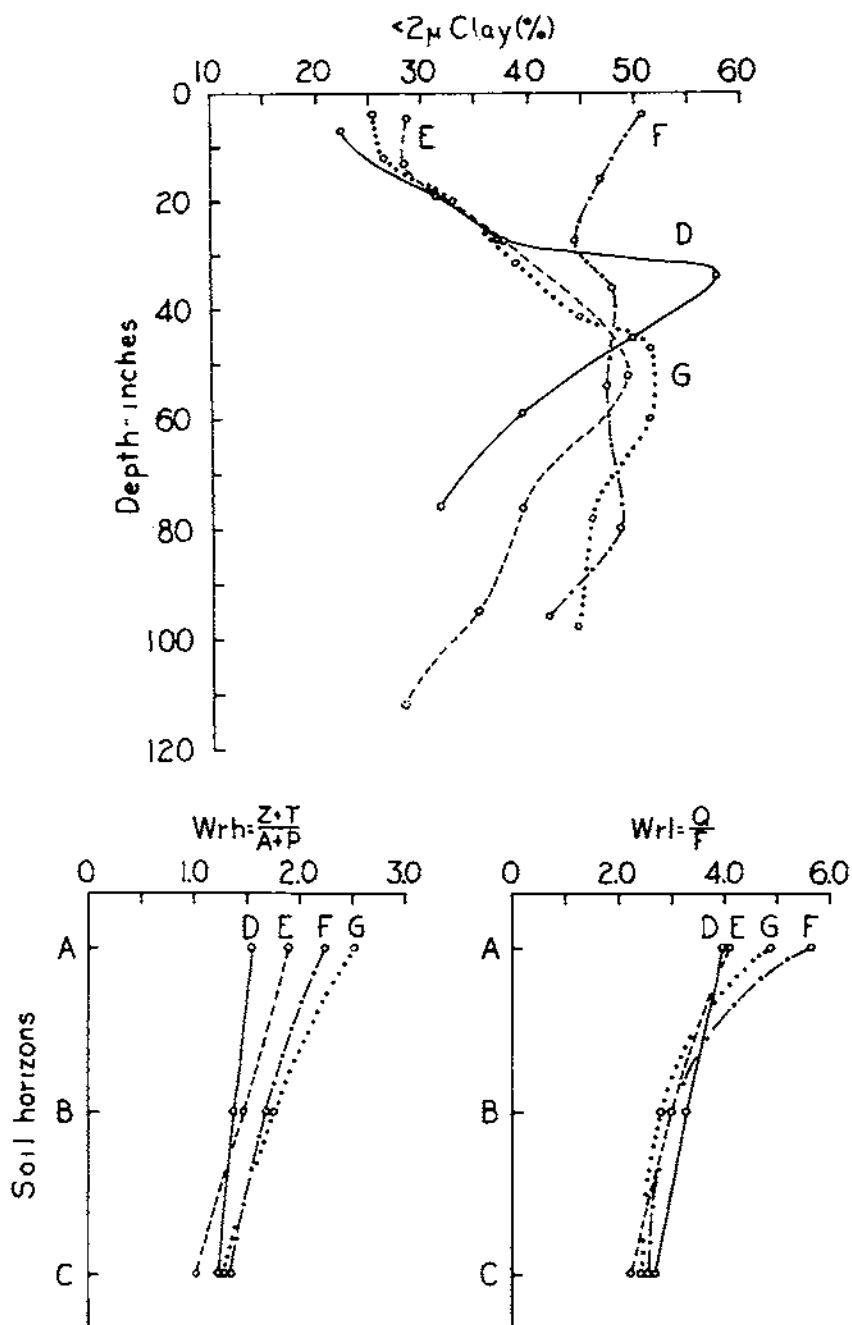

FIGURE 38.—Clay content and weathering ratios of heavy mineral fraction (Wrh) and light mineral fraction (Wrl) of Yarmouth-Sangamon paleosols.

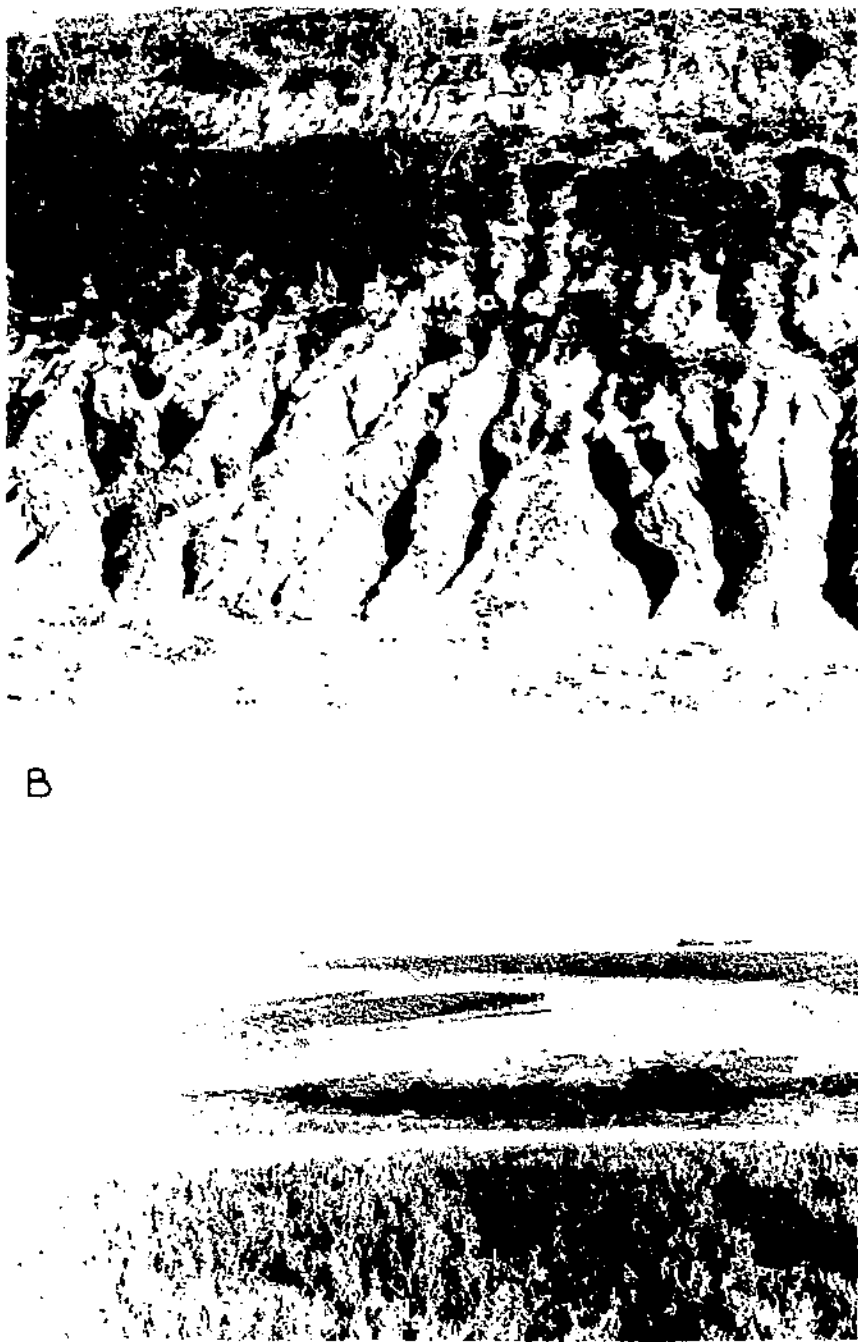

FIGURE 39.—Yarmouth-Sangamon paleosols (gumbotil) in road cut (A) and outcropping on Recent slope (B). Note poor stand of alfalfa in outcrop on slope.

IIA _{21b} 62-71 inches	Dark yellowish brown (10YR 4/4) light silty clay loam; weak fine subangular blocky; firm; gritty with only resistant minerals visible; leached upper horizon of Yarmouth-Sangamon paleosolum in Kansan till.
IIA _{22b} 71-79 inches	Light brownish gray (10YR 6/2) light silty clay loam; mottled with yellowish brown (10YR 5/4); moderate fine subangular blocky; firm; sparse clay skins in lower part of horizon; gritty with only resistant minerals visible; leached.
IIB _{1gb} 79-99 inches	Grayish brown (2.5Y 5/2) heavy silty clay loam; mottled with dark yellowish brown (10YR 4/4); moderate medium subangular blocky; firm but plastic; clay skins on aggregate faces; gritty with only resistant minerals visible; leached.
IIB _{2gb} 99-129	Gray (10YR 5/1) heavy silty clay; mottled with yellowish brown (10YR 5/8); strong medium subangular blocky; very plastic; clay skins on aggregate faces; gritty with only resistant minerals visible; leached.
IIB _{1rb} 129-146 inches	Light gray (5Y 6/1) heavy silty clay loam; mottled with yellowish brown (10YR 5/8); moderate medium subangular blocky; moderately plastic; clay skins along vertical faces in lower part of horizon; weatherable minerals visible in lower part; leached; lower part of Yarmouth-Sangamon paleosolum in Kansan till.
IIC _{11rb} 146-176 inches	Gray (5Y 5/1) clay loam; mottled with dark yellowish brown (10YR 4/4); coarse angular blocky; firm; gritty with weatherable minerals; deoxidized and leached Kansan till.
IIC _{12b} 176+ inches	Yellowish brown (10YR 5/8) clay loam; mottled with light gray (5Y 7/1); coarse angular blocky; firm; gritty and pebbly with weatherable minerals; oxidized and leached Kansan till.

In the B_{2gb} and B_{3gb} horizons of this paleosol vertical root tubules more than an inch in diameter are common. The root tubules are filled with clay that is laminarily oriented with their walls. In cross section the clay is concentrically banded. The tubules and cores are indicative of a forest environment on the paleosolic surface.

This paleosol (fig. 38, E) is comparable morphologically to modern Gray-Brown Podzolic soils but the development is more intensive than modern analogues in Iowa. A thick (17 inches) A_{2b} horizon with a clay content of 38 percent overlies a thick (20 inches) B_{1b} horizon with a clay content of 37 percent. In the B_{2b} horizon the maximum accumulation of clay is 49 percent. The paleosol may be classified as a paleo-Gray Brown Podzolic soil.

In the paleo-Planosol the clay content increases from 32 percent in the thin A_{2b} horizon to 58 percent in the B_{2b} horizon in a vertical distance of 5 inches. In the paleo-Gray Brown Podzolic soil the clay content increases from 38 percent in the A_{2b} horizon to a maximum of 49 percent in the B_{2b} horizon in a vertical distance of 20 inches (cf. fig. 38, D and E).

The part of the solum B_{1gb}-B_{3gb} is the "gumbotil" of Pleistocene-geology terminology.

In the swales, or more poorly aerated positions, on the Yarmouth-Sangamon surface, a different kind of paleosol occurs and in the South Turkey Creek area has the following morphology:

Section F (pl. II: 1.35, 6.30):

0-48 inches	Tazewell loess with modern soil in upper part.
IA _{1b} 48-57 inches	Very dark gray (N3) heavy silty clay; coarse angular blocky; plastic; clay skins on aggregate faces; iron oxide concretions abundant; very little grit; leached "wash" on Kansan till; upper part of Yarmouth-Sangamon paleosolum.

IA _{2ab} 57-71 inches	Gray (10YR 5/1) silty clay; coarse angular blocky; plastic; clay skins on aggregate faces; iron oxide concretions common; very little grit but only resistant minerals visible; leached "wash" on Kansan till.
IB _{1ab} 71-79 inches	Gray (10YR 5/1) silty clay; strong coarse angular blocky; very plastic and compact; clay skins on aggregate faces; very little grit but only resistant minerals visible; leached "wash" on Kansan till.
IB _{2ab} 79-88 inches	Dark gray (10YR 4/1) silty clay; strong coarse angular blocky; very plastic and compact; clay skins on aggregate faces; moderately gritty but only resistant minerals visible; leached "wash" on Kansan till.
IIB _{2ab} 88-113 inches	Light gray (10YR 6/1) silty clay; coarse angular blocky; plastic; clay skins on aggregate faces; gritty but with weatherable minerals visible in lower part; leached Kansan till.
IIB _{3ab} 113-133 inches	Gray (10YR 6/1) silty clay; coarse angular blocky; clay skins on aggregate faces in upper part, channelized vertically in lower part; gritty with weatherable minerals; leached; lower part of Yarmouth-Sangamon paleosol in Kansan till.
IIC _{1b} 133+ inches	Yellowish brown (10YR 5/8) clay loam; mottled with gray (10YR 6/1); coarse angular blocky; firm; gritty with weatherable minerals; oxidized and leached Kansan till.

This paleosol is comparable morphologically to modern Humic Gley soils (48, p. 449). Its profile of clay distribution (fig. 38, F) indicates abundant clay formation but little translocation. The horizons IA_{1b} to IIB_{3ab} are the "gumbotil" of Pleistocene-geology terminology.

Total sand content in horizons, IA_{1b} to IIB_{3ab} is less than 6 percent, which is abnormal for Kansan till. Sand content gradually increases to 15 percent in the IIB_{3ab} horizon and increases slightly with greater depth. The material in the upper part of the solum is probably finer textured sediment washed from the adjacent shallow slopes around and above the swale in the Yarmouth-Sangamon surface. By weathering contemporaneous with accretion or subsequent to sedimentation, the sediment has become incorporated into a "giant" solum 85 inches thick.

The finer textured upper solum may also represent Loveland loess, thin increments of which should occupy a stratigraphic position between recognizable weathered Kansan till and the basal Wisconsin loess. However, Loveland loess, per se, cannot be recognized because of the intensive weathering the zone has undergone.

Another kind of paleosol occurs on the Yarmouth-Sangamon surface (*section G*).²⁰ Its curve of clay distribution (fig. 38, G) suggests that it may be an intergrade between a paleo-Humic Gley and a paleo-Gray Brown Podzolic soil or paleo-Planosol. The site of the intergrade occurs on a slope between the better aerated crest of a swell and the poorer aerated swale. The clay distribution in the upper part of the paleosolum is similar to that of the paleo-Gray Brown Podzolic soil and paleo-Planosol. In the lower part of the paleosolum the clay distribution is similar to that of the paleo-Humic Gley.

A problem involved in studies of paleosols, whether buried or exposed, is the application of proper laboratory analytical methods so that characteristics of the soils may be compared. Standard

²⁰ Section G is not described in detail in this report. Textural and mineralogical data of the paleosol are included for comparison.

soil-chemistry methods cannot be applied. When the soils originally developed in Kansan till, leaching removed bases to great depths below the solum of the Yarmouth-Sangamon paleosol. The soil was buried subsequently by calcareous Wisconsin loess, which later was leached. Solutions percolating downward undoubtedly enriched the buried paleosolum. Field and laboratory studies show such secondary enrichment.

Carbonate concretions commonly occur in the upper part of the paleosol, even though the matrix of the soil is leached. Pipestems (vertically elongate, cylindrical iron-oxide concretions) in the paleosol can be traced upward into the lower part of the overlying Wisconsin loess. These are field evidences that the paleosol has been enriched in calcium and iron.

Hydrogen-ion concentrations are misleading. In the paleo-Planosol (section D) the A_{2b} horizon has a pH of 6.4 and the B_{2b} horizon of 6.6. Yet Ulrich (74, p. 326) reported that less intensely weathered modern Planosols in Iowa have pH values in the A_2 horizon of 5.0 and in the B_2 horizon of 5.6.

A detailed mineralogical study of the very fine sand fractions (0.62-0.125 m.m.) of the horizons can be applied to paleosols (48, p. 447-450).

Among the heavy minerals Dryden and Dryden (13) showed the following stability indices: zircon, 100; tourmaline, 80; the amphibole, hornblende, 5; and the pyroxene, hypersthene, 1. Thus, a weathering ratio for heavy minerals (Wr_h , fig. 38) may be established from the percentage by count of the resistant minerals zircon and tourmaline to the percentage by count of the less resistant mineral groups, amphiboles and pyroxenes.

Analysis of the mineralogy of the heavy-mineral fractions of the A_{2b} , B_{2b} , and C_{1b} horizons of the paleo-Planosol (fig. 38, D) shows an orderly decrease of the weathering ratios, Wr_h . The A_{2b} horizon is more intensely weathered than the B_{2b} horizon, which in turn is more intensely weathered than the C_{1b} horizon (table 23).

Goldich (18) showed the increasing resistance to weathering among the light minerals of the series, plagioclase, microcline-orthoclase, and quartz. Thus, a weathering ratio for light minerals (fig. 38, Wr_l) may be established from the percentage by count of the resistant quartz to the percentage by count of more weatherable feldspars.

Analysis of the mineralogy of the light-mineral fraction of the A_{2b} , B_{2b} , and C_{1b} horizons of the paleo-Planosol (D) shows an orderly decrease of the weathering ratios (fig. 38, Wr_l).

The paleo-Humic Gley and paleo-intergrade apparently are more intensely weathered in the upper parts of the sola than are the better aerated or drained paleo-Planosol (D) and paleo-Gray Brown Podzolic soil (E). Weathering ratios are greater. The greater weathering in the paleo-Humic Gley and paleo-intergrade may be explained by pedogenetic processes operative in a more moist environment,²⁷ partial weathering of primary minerals on

²⁷ Bray (4, 5) pointed out the more advanced chemical weathering in the wetter modern soils developed in loess in Illinois.

TABLE 23.—Abundance of major resistant and weatherable minerals in very fine sand fraction: Yarmouth-Sangamon paleosols

Soil and horizons	Heavy minerals			Light minerals		
	Re-sistant ¹	Weather-able ²	Wrh ³	Re-sistant ⁴	Weather-able ⁵	Wrl ⁶
Paleosol D	Percent	Percent		Percent	Percent	
A ₁ -----	56	36	1.55	80	20	4.00
B ₂ -----	54	39	1.38	76	24	3.16
C ₁ -----	49	40	1.24	73	27	2.70
Paleosol E						
A ₂ -----	51	31	1.90	80	19	4.01
B ₂ -----	48	33	1.46	75	25	3.00
C ₁ -----	45	44	1.01	69	31	2.22
Paleosol F						
A ₂ -----	63	28	2.25	85	15	5.66
B ₂ -----	56	32	1.73	75	25	3.00
C ₁ -----	55	34	1.34	72	28	2.57
Paleosol G						
A ₂ -----	53	21	2.52	83	17	4.88
B ₂ -----	50	29	1.75	74	26	2.85
C ₁ -----	49	39	1.27	71	29	2.45

¹ Zircon and tourmaline.

² Amphiboles and pyroxenes: dominantly hornblende, hypersthene, enstatite.

³ $Wrh = \frac{\text{zircon} + \text{tourmaline}}{\text{amphiboles} + \text{pyroxenes}}$; ratios to base 1.

⁴ Quartz.

⁵ Feldspars (orthoclase, microcline, plagioclase).

⁶ $Wrl = \frac{\text{quartz}}{\text{feldspar}}$; ratios to base 1.

⁷ Percentages by count.

the slopes above the swales on the Yarmouth-Sangamon surface prior to wash into the swales and slow accretion with final breakdown, or a combination of both factors.

In all of the paleosols only resistant chert, quartz, quartzite, and sandstone occur in the coarser sand fractions (2.0–0.5 m.m.) of the horizons of the sola. In the C horizons fragments of weatherable granite, diorite, and basalt, as well as the more resistant mineral types, are common.

The Yarmouth-Sangamon paleosols, indicative of the geomorphic surface, are readily identifiable on the landscape. They occur near the highest level of the landscape. They may be identified by their gray colors, excessive thicknesses of sola, heavy-textured B horizons (clay or heavy silty clay), strong subangular blocky structure in the B horizons, and by the absence of weatherable mineral material in the coarser particle-size fractions throughout the sola.

Where these paleosols crop out on the modern surface, they are considered in the scheme of classification of soils as the Clarinda series.

Late Sangamon Surface
PEDIMENT

The Late Sangamon erosion surface occurs as the intermediate level of the landscape on most of the interfluves in the South Turkey Creek area (pl. II). Where the low level of the landscape is not present, the Late Sangamon surface extends from the valley shoulder along a level or slightly rising slope and then up a steeper slope to the level of the Yarmouth-Sangamon surface. For example, along a traverse (pl. II: F.12, 3.85-C.55, 3.85) the surface rises gradually from an elevation of 1,305 feet at the valley shoulder to an elevation of 1,314 feet at the east edge of the Wisconsin loess outlier (pl. II: E.42, 3.85) in a distance of 725 feet, a slope of 1.2 percent (fig. 40). The surface then rises more steeply westward to an elevation of 1,327 feet at the center of the loess outlier (pl. II: E.15, 3.85) in a distance of 300 feet on a slope of 4.3 percent. The same slope of the surface is maintained to the westward of the loess outlier where the Late Sangamon pediment is exposed on the modern surface (pl. III). The longitudinal profile of the Late Sangamon surface is concave upward (fig. 40). The part of the surface with a low gradient is a pediment footslope and that with steeper gradient, which rises to the Yarmouth-Sangamon surface, is the pediment backslope.

The Late Sangamon pediment is paired across the main drainage, South Turkey Creek (pl. II: G.80, 2.45 and 1.2, 3.2; E.80, 3.85 and G.30, 4.85; E.2, 5.0 and F.7, 5.3). The pediment occurs above and around the major tributaries, West Branch and East Branch, of South Turkey. Across East Branch the relict pediment surfaces are paired (pl. II: H.5, 4.6 and G.6, 5.4; G.85, 5.60 and H.85, 5.4). Such pairing of surfaces across valleys is considered to be evidence of cyclic erosion (70, pp. 157-158). The longitudinal profiles of the relict pediment surfaces around West Branch characteristically are concave upward (fig. 36).

In the South Turkey Creek area the occurrence of the Late Sangamon pediment on interfluve flanks below the Yarmouth-Sangamon surface on the upland divide is the same relationship of surfaces that was determined along the regional traverse in the

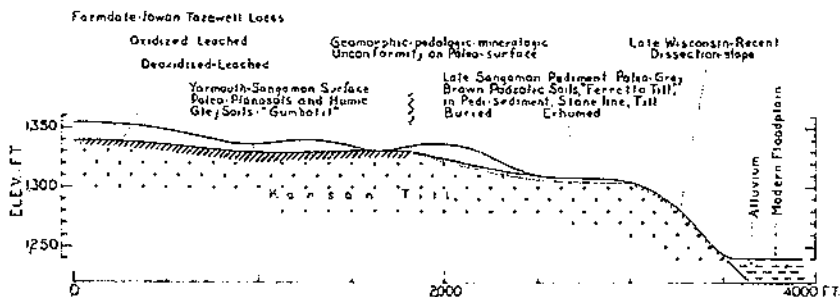

FIGURE 40.—Geomorphic-profile traverse (pl. III: C.25, 4.10-F.65, 3.85) showing relationship of Late Sangamon pediment to Yarmouth-Sangamon surface.

vicinity of Adair. The relationships of surfaces can be determined by direct tracing from the Adair area throughout the Greenfield quadrangle.

The geographic and elevation distributions of the Late Sangamon pediment relative to the Yarmouth-Sangamon surface indicate that the Late Sangamon surface was cut into Kansan till below the Yarmouth-Sangamon level.

Surficial cover. The pediment surface on Kansan till is marked by a stone line at the till surface (fig. 41). The stone line is composed of pebbles, cobbles, and boulders, generally crystalline rocks, that are common in the underlying till. The stone line is a concentrate of lag-gravel which developed as a result of the removal of finer textured materials during evolution of the pediment surface.

The stone line can be traced continuously both longitudinally and transversely on the relict pediment surfaces of the interfluves. Longitudinally the stone line rises with the pediment backslope and disappears from the landscape at the Yarmouth-Sangamon level (fig. 40). The disappearance of the stone line marks the headward limit of pediment development. Transversely on the relict pediment surface, the stone line is beveled by more recent dissection slopes, on which the stone line outcrops.

The stone line is overlain by fine textured sediment that is similar in composition to the constituents of the underlying till. This sediment has been termed *pedi-sediment* (50, p. 403), that is, sediment that has been translocated on a pedimented erosion surface. The *pedi-sediment* can be traced longitudinally along the interfluve axes up the pediment backslope where the *pedis*ediment thins out at the Yarmouth-Sangamon level. The line or zone of thinning out marks the headward limit of source of *pedi-sediment*

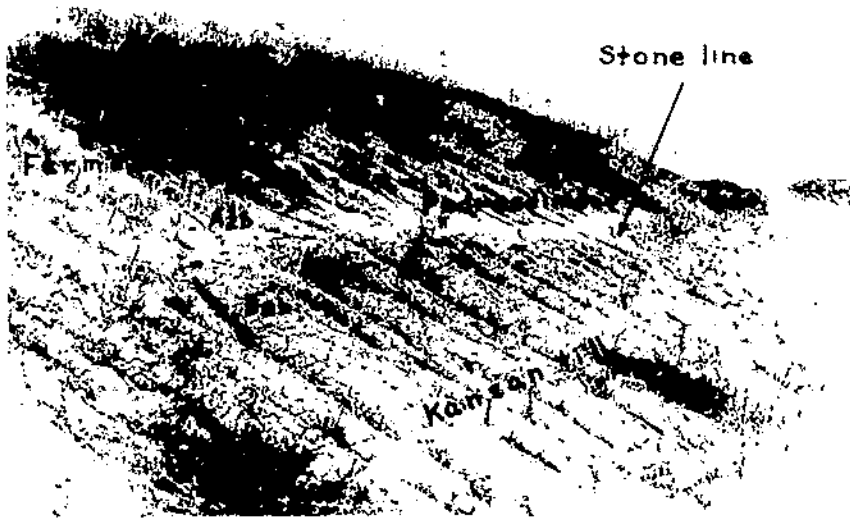

FIGURE 41.—Stone line marking Late Sangamon pediment surface on Kansan till. Finer textured *pedi-sediment* overlies stone line.

on the pediment surface. Transverse to the axes of the inter-fluves, the pedi-sediment is beveled by more recent dissection slopes, on which the pedi-sediment outcrops.

It is not possible to assess accurately the nature of the original pedi-sediment, because subsequent to stabilization of the pediment surface, weathering in the pedi-sediment, stone line, and upper part of the Kansan till resulted in the formation of a well-developed soil (fig. 42). An A₂ horizon developed in the upper part of the pedi-sediment, and clay has been translocated from this horizon to underlying horizons. As a result, the clay content is only 17 percent. A B₁ horizon developed in the lower part of the pedi-sediment, so that clay probably has accumulated in this horizon, but even so, the clay content is less than that of relatively unaltered till (fig. 42, III C). It should be noted, however, that the total sand content is about the same throughout the 21 inches of pedi-sediment. This sand content does not differ appreciably from that of unaltered till. It seems apparent that one result of sedimentation on the pediment was the removal of finer material.

A second result of sedimentation on the pediment was the concentration of coarse particle-sized material as a lag gravel (stone line). Coarse pebbles, cobbles, and boulders that are common in the underlying Kansan till do not occur in the pedi-sediment. Apparently the running water that cut the pediment surface was not capable of transporting coarse particles but could transport finer ones.

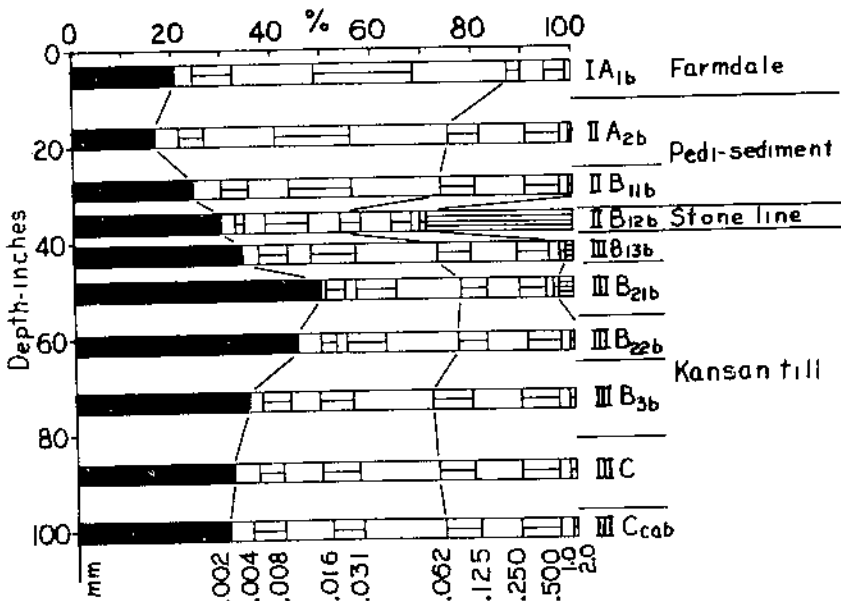

FIGURE 42.—Textural relationship of Farmdale loess, pedi-sediment, stone line, and Kansan till with a superimposed Late Sangamon paleosol.

During sedimentation the pedi-sediment was selectively sorted. Evidence of this is found in the shapes of grains in the source material, Kansan till, relative to the stone line and overlying pedi-sediment. The Kansan till contains medium and coarse sand particles that range from rounded to subrounded to subangular to angular. For analyses of grains in two sections on the Late Sangamon pediment two classes were established: rounded, which includes both rounded and subrounded grains; and angular, which includes both subangular and angular grains. In one section the Kansan till contained 71 percent (percentages by grain counts) angular and 29 percent rounded grains. The overlying stone line contained 75 percent angular and 26 percent rounded grains. But the pedi-sediment contained only 62 percent angular and 38 percent rounded grains. In the second section the Kansan till contained 70 percent angular and 30 percent rounded grains. The overlying stone line 72 percent angular and 28 percent rounded grains. But the pedi-sediment contained only 56 percent angular and 44 percent rounded grains.

In both sections there is an increase of angular grains lodged in the stone line relative to the amount of the underlying till. In both sections there is a decided increase of rounded grains in the pedi-sediment relative to the amounts in the underlying lag gravel and till. The data suggest that there was a selective preference for transport of rounded grains by the water that cut the pediment surface and developed the lag gravel. Because of the short distances on the pediment surface (pl. II), it is doubtful that the abundance of rounded grains in the pedi-sediment could be the result of rounding while in transport on the pediment surface.

Thus, the Late Sangamon pediment is characterized by a complex association of materials. The surface is underlain by Kansan till, is marked by lag gravel stone line, and is overlain by variable thicknesses of pedi-sediment. In most places the stone line is only a few inches thick so that practically the superimposed soil formed in two materials.

Paleosols. In the South Turkey Creek area the paleosols on the Late Sangamon pediment are rather uniform morphologically. In general a light colored, light textured A_2 horizon grades downward into a heavier textured B_1 horizon, which in turn grades to a heavier textured B_2 horizon. A stone line occurs either in the lower part of the B_1 or the upper part of the B_2 horizons. Thus, the upper part of the solum is developed in pedi-sediment and the lower part in Kansan till. B_3 and C_1 horizons are in Kansan till (fig. 43).

Late Sangamon paleosols are buried beneath Wisconsin loess on the intermediate level of the landscape or they may be exhumed by stripping of loess from the same level.

The Late Sangamon pediment on which the paleosols occur was a surface of low relief with transverse level and slightly rounded interfluves that stood 5 to 10 feet above adjacent drainages. On the surface there were positions of good, intermediate, and poor aeration and drainage. A profile on a well-drained position is:



FIGURE 43.—Late Sangamon-pediment paleosol developed in pedi-sediment, stone line, and Kansan till.

Section H: (pl. II: 1.35, 3.35)

- 0-40 inches Tazewell loess with modern soil in upper part.
- IA_{1b} 40-52 inches Dark brown (10YR 4/3) silt loam; weak medium granular; friable; leached Farmdale loess.
- IIA_{2b} 52-62 inches Yellowish brown (10YR 5/4) silt loam; weak coarse platy; friable; gritty with weatherable minerals visible; leached Late Sangamon pedi-sediment.
- IIB_{1b} 62-67 inches Yellowish brown (10YR 5/4) silty clay loam; weak medium subangular blocky; sparse clay skins on aggregate faces; friable; gritty with weatherable minerals visible; leached Late Sangamon pedi-sediment. At base of this horizon is dark brown (7.5YR 4/4) gravelly loam with abundant cobbles of granite, basalt, quartzite, quartz; Late Sangamon stone line.
- IIIB_{2b} 67-80 inches Dark brown (7.5YR 4/4) clay; mottled with reddish brown (5YR 4/4) and red (2.5YR 3/4); strong medium subangular blocky; abundant clay skins on aggregate faces; plastic; very gritty; pebbly with weatherable minerals; leached Kansan till.
- IIIB_{3b} 80-87 inches Strong brown (7.5YR 5/8) clay loam; moderate medium subangular blocky; moderately plastic; clay skins moderately abundant on aggregate faces; very gritty and pebbly with weatherable minerals visible; leached Kansan till.

IIIC _{11b} 87-107 inches	Strong brown (7.5YR 5/6) light clay loam; coarse angular blocky; firm; clay skins channelized along vertical tubules; gritty and pebbly with weatherable minerals visible; leached Kansan till.
IIIC _{12b} 107-122 inches	Yellowish brown (10YR 5/6) clay loam; mottled with light gray (5Y 7/1); coarse angular blocky; firm; sparse clay skins channelized along vertical tubules; gritty with weatherable minerals; leached Kansan till.
IIIC _{entb} 122+ inches	Yellowish brown (10YR 5/6) clay loam; coarse angular blocky; firm; carbonate concretions up to 3 inches in diameter; gritty and pebbly with weatherable minerals; calcareous Kansan till.

This paleosol is similar morphologically to modern Gray-Brown Podzolic soils. The colors differ in that stronger chromas and redder hues prevail. The clay distribution curve (fig. 44, H) is not dissimilar to the modern Gray-Brown Podzolic Lindley silt loam (48, p. 451). The horizons B_{2b} and B_{3b} are the "ferretto" till of Pleistocene-geology terminology.

Two other Late Sangamon pediment paleosols (fig. 44, I and J)²⁸ have similar morphologies and clay distribution profiles. The two other paleosols differ from each other and from profile H in thickness of and depth to horizons (fig. 44). These characteristics are related directly to the thickness of pedi-sediment above the stone line. For example, in profile I the pedi-sediment is 23 inches thick and the depth to the zone of maximum clay accumulation is 32 inches. The values of this relationship in profile H are 29 and 37 inches and in profile J are 36 and 50 inches. The upper part of the heavier textured till has acted as a catchment zone for the clay translocated from the lighter textured pedi-sediment above.

The paleo-Gray Brown Podzolic soils of the Late Sangamon pediment are or were buried beneath Farmdale-Tazewell loess that was originally calcareous. This loess is leached, and the underlying paleosol has been enriched by material carried downward in solutions. Some buried Gray-Brown Podzolic soils have pH values that range only from 6.4 to 6.8 and base saturations of about 90 percent throughout the paleosol. But in modern Gray-Brown Podzolic soils on Recent slopes, the soils have pH values of 4.8 to 5.8 and base saturations of 60 to 70 percent (48, p. 451).

Weathering ratios of the heavy mineral fractions in profile H show an orderly, progressive decrease from the A₂ horizon to the B₂ and to the C horizons (fig. 44, table 24). Profiles I and J show somewhat similar relationships of the ratio W_{rh}.

Weathering ratios of the light material fractions in profile H also show an orderly, progressive decrease from the A₂ horizon to the B₂ and to the C₁ horizons (fig. 44, table 24). Profiles I and J show similar relationships of the ratio W_{rl}.

The morphological continuity of the paleo-Gray Brown Podzolic soil profiles, even though interrupted by a stone line, and the relationships of weathering ratios both show that the soil horizons are genetically related.

²⁸ Section I (pl. IV: C.65, 4.15) is described in another part of this report. Section J (pl. IV: A.6, 2.8), because of its similarity to the other two, is not described.

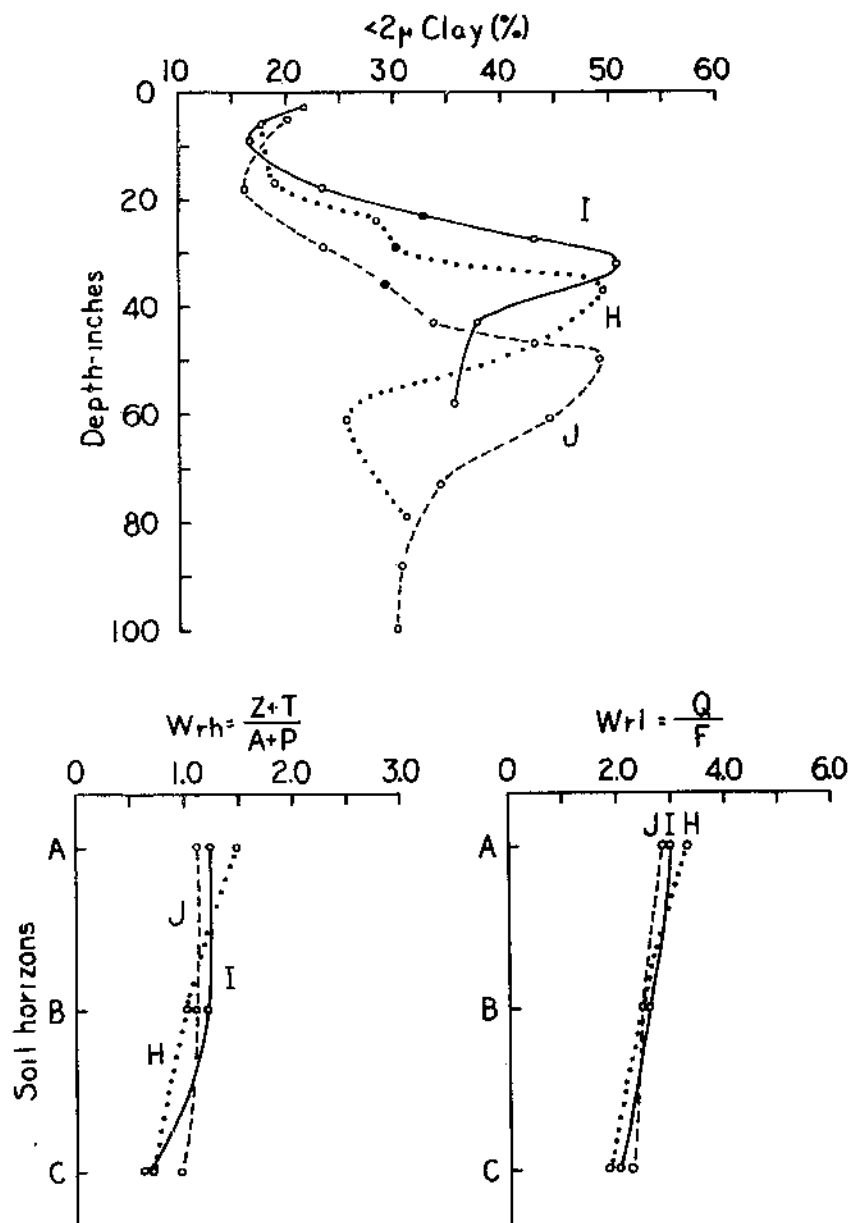

FIGURE 44.—Clay content and weathering ratios of heavy mineral fraction (Wr_h) and light mineral fraction (Wr_l) of the paleosols on the Late Sangamon pediment.

In the coarser sand fractions (2.0–0.5 m.m.) weatherable rock material such as granite, diorite, and basalt is abundant in all horizons of the sola. Resistant materials are present also.

TABLE 24.—Abundance of major resistant and weatherable minerals in very fine sand fraction: Late Sangamon paleosols

Soil and horizons	Heavy minerals			Light minerals		
	Re-sistant ¹	Weather-able ²	Wrh ³	Re-sistant ⁴	Weather-able ⁵	Wrl ⁶
Paleosol H	<i>Percent</i>	<i>Percent</i>		<i>Percent</i>	<i>Percent</i>	
A ₂ -----	56	37	1.49	77	23	3.34
B ₂ -----	49	48	1.03	71	29	2.45
C ₁ -----	38	55	0.69	65	35	1.86
Paleosol I						
A ₂ -----	53	43	1.22	75	25	3.00
B ₂ -----	52	42	1.01	72	28	2.57
C ₁ -----	38	58	0.66	67	33	2.03
Paleosol J						
A ₂ -----	51	46	1.11	74	26	2.85
B ₂ -----	51	46	1.11	71	29	2.45
C ₁ -----	43	44	0.97	69	31	2.22
Paleosol K						
A ₂ -----	53	37	1.43			
B ₂ -----	43	42	1.04			
C ₁ -----	39	53	0.74			
Paleosol L						
A ₂ -----	49	29	1.70			
B ₂ -----	47	32	1.45			
C ₁ -----	39	47	0.82			

¹ Zircon and tourmaline.

² Amphiboles and pyroxenes: dominantly hornblende, hypersthene, enstatite.

³ $Wrh = \frac{\text{zircon} + \text{tourmaline}}{\text{amphiboles} + \text{pyroxenes}}$; ratios to base 1.

⁴ Quartz.

⁵ Feldspars (orthoclase, microcline, plagioclase).

⁶ $Wrl = \frac{\text{quartz}}{\text{feldspar}}$; ratios to base 1.

⁷ Percentages by count.

The Late Sangamon-pediment paleosols are not as intensely developed as the paleosols of the Yarmouth-Sangamon surface. The average thickness of the sola of the Late Sangamon paleosols is 52 inches, average thickness of B horizons is 39 inches, and the average clay content of B₂ horizons is 49.7 percent. The Yarmouth-Sangamon paleosols have greater development with an average thickness of the sola of 81 inches, average thickness of B horizons of 61 inches, and average clay content of B₂ horizons of 52.2 percent.

The Late Sangamon-pediment paleosols are less intensively weathered than the Yarmouth-Sangamon paleosols (table 25). They have smaller weathering ratios in both the heavy and light mineral fractions in all horizons.

Thus, where the Late Sangamon pediment rises to the level of the Yarmouth-Sangamon surface, there are geographically juxtaposed two soil landscapes that differ distinctly. Not only are the surfaces separated by a geomorphic unconformity but also by a

TABLE 25.—Comparison of weathering ratios of horizons of Late Sangamon pediment paleosols and Yarmouth-Sangamon paleosols

Soil	Wrh			Wrl		
	A ₂ or A ₃	B ₂	C ₁	A ₂ or A ₃	B ₂	C ₁
Late Sangamon						
H.....	¹ 1.49	1.03	0.69	3.34	2.45	1.86
I.....	1.22	1.21	0.66	3.00	2.57	2.03
J.....	1.32	1.11	0.97	2.85	2.45	2.22
Average.....	1.28	1.11	0.78	3.06	2.49	2.03
Yarmouth-Sangamon						
D.....	1.55	1.38	1.24	4.00	3.16	2.70
E.....	1.90	1.46	1.01	4.01	3.00	2.22
F.....	2.25	1.73	1.34	5.66	3.00	2.57
G.....	2.52	1.75	1.27	4.88	2.85	2.45
Average.....	2.06	1.58	1.22	4.64	3.00	2.48

¹ All values are for resistants relative to unity of weatherables.

pedological unconformity. The morphologies and degrees of development of the soils differ. The surfaces are separated also by a mineralogic unconformity. The soils of the two surfaces are characterized by different degrees of mineral weathering (fig. 40).

Late Sangamon pediment paleosols that crop out on the modern surface are classed as Adair series. Where the paleosolic surface between the Late Sangamon pediment and Yarmouth-Sangamon surface crops out on the modern surface, the paleosols are classified as Adair-Clarinda intergrade.

VALLEY FILL

The geographic and geomorphic distributions of the Late Sangamon pediments relative to the Yarmouth-Sangamon surface in the South Turkey Creek area (pl. II) indicate that considerable volumes of sediment must have been moved during the evolution of the lower surface. With the exception of the thin pedi-sediment that overlies the stone line of the pediment, no other Late Sangamon sediment was found in the area. The thin pedi-sediment veneer hardly accounts for the amount of sediment that must have been produced.

However, Late Sangamon sediment including pedi-sediment were found in the North Turkey Creek area, which has the same general configuration as in the South Turkey Creek area. Along the interflaves a sequence of stepped levels rises from the valley shoulders to the upland divide. Such stepped levels along interflaves are identifiable on a topographic map (fig. 45, A to B, C to B, D to E).

The North Turkey Creek area differs from the South Turkey Creek area in that the right valley walls of the major streams, North Turkey Creek (south wall) and North Branch (west wall), are more steep and sheer than the left valley walls. During Recent

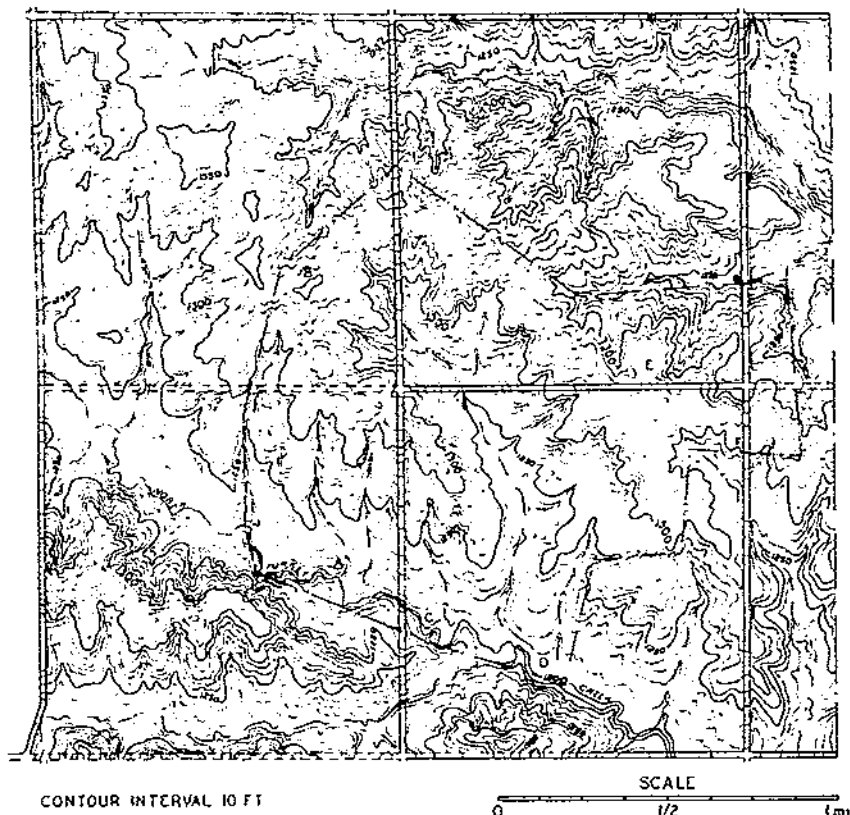

FIGURE 45.—Topographic map of North Turkey Creek area. A-B . . . F-G locate geomorphic profile sections (figs. 47, 48, 49).

dissection the streams have impinged on their right walls and have steepened them. It is on the left sides of the valleys that the geomorphic record is best preserved (pl. IV).

The pediment, valley-slope fan, and flood plain with associated valley fill, which now occur as relict surfaces along the axes of present interfluves, form conspicuous parts of the present landscape (fig. 46).

Flood plain, fan, and pediment. Along the interfluve A to B (fig. 45; pl. IV: B.50, 5.75-B.2, 2.1) from the present valley shoulder northward for a distance of 390 feet the summit has 0 percent slope (fig. 47). A thin loess mantle (41 inches thick) caps this surface. Beneath the loess a light-textured, light-colored A_{h} horizon of a paleosol grades downward into a heavier textured, reddish brown B_{h} horizon. Underlying the B_{h} horizon to depths of 15 feet (in borings) are bedded sands and gravels (loam and sand loam textures) but no stone line.

At station 1,000 N the surficial loess is 75 inches thick and overlies a similar paleosol formed in similar kinds of stratified allu-

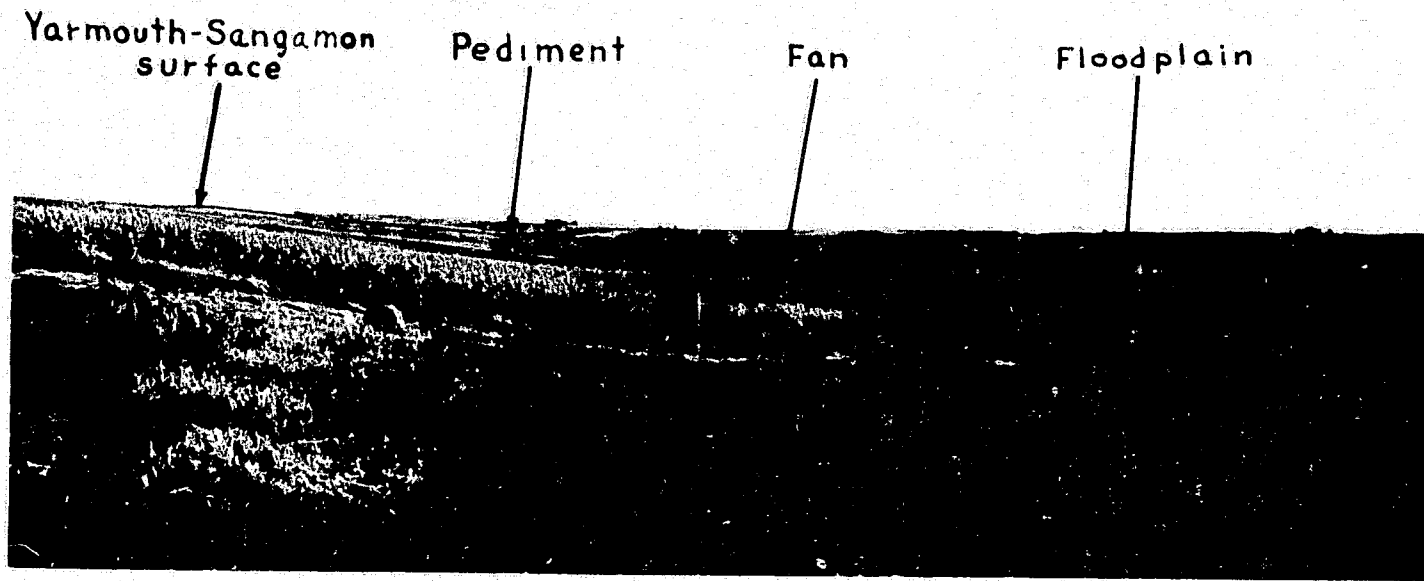

FIGURE 46.—Topographic expressions of Yarmouth-Sangamon surface and Late Sangamon pediment, valley-slope fan, and flood plain with associated valley fill in present landscape along North Turkey Creek.

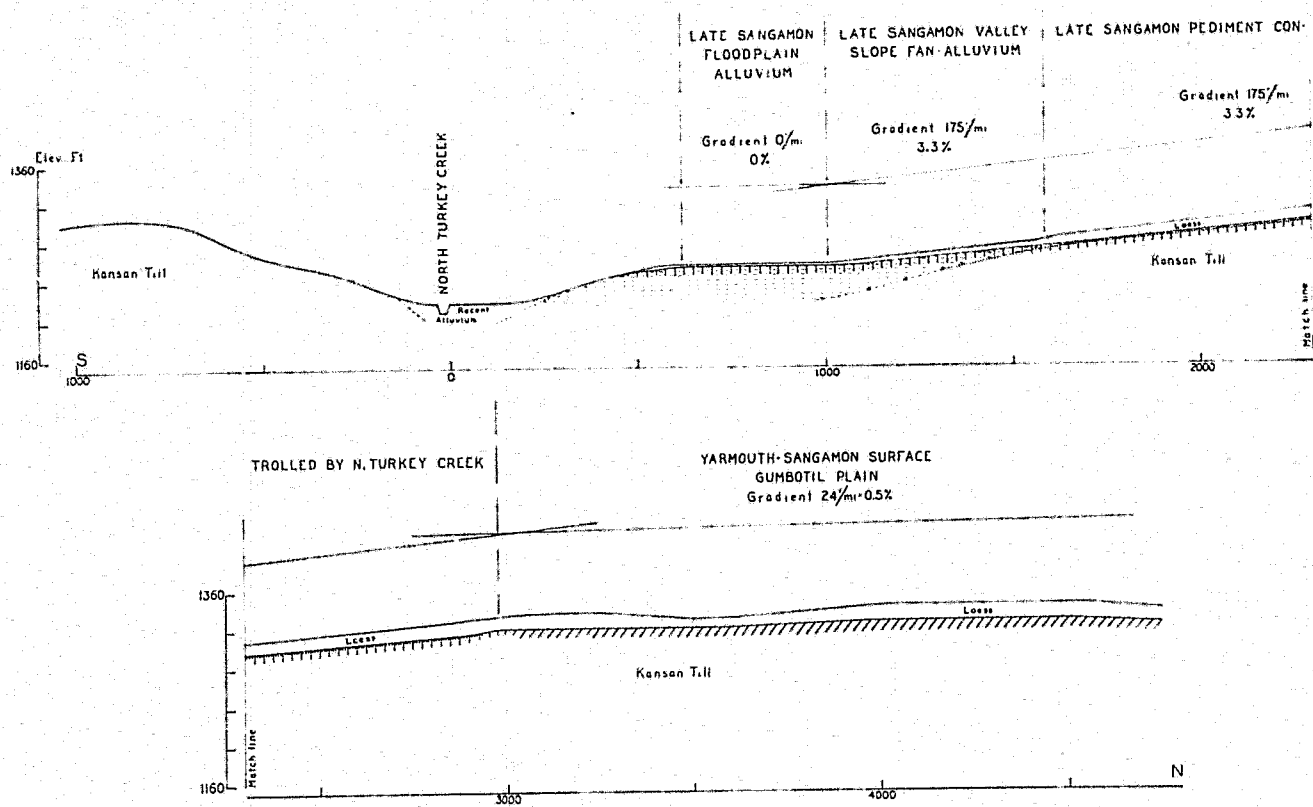

FIGURE 47.—Geomorphic profile along axis of interfluvium north of North Turkey Creek (fig. 45, A-B; pl. IV: B.40, 5.75-B.35, 2.225).

vium. The paleosolic surface rises northward up a slope of 3.3 percent. At station 1,320 N there was a stone line overlying till at a depth of $7\frac{1}{2}$ feet below the paleosol surface. A station 1,580 N at the distal edge of the footslope of the pediment, the stone line was beneath 25 inches of pedi-sediment, under 104 inches of loess. Between stations 1,320 and 1,580 N in a distance of 260 feet, the stone line rises from an elevation of 1,304 to 1,315 feet, and has a 4.2 percent slope.

From station 1,580 N the pediment marked by the stone line rises with a 3.3 percent slope to the level of the Yarmouth-Sangamon surface at station 3,000 N. The stone line is veneered with pedi-sediment that ranges from 18 to 25 inches in thickness. The loess thickness increases to 171 inches on the upland surface.

Thus, along the interfluvium (fig. 45, B-A), a Late Sangamon pediment cut below the Yarmouth-Sangamon surface slopes downward to the south at 3.3 percent to an alluvial fill, whose surface maintains the 3.3 percent slope but its base slopes southward at 4.2 percent. Farther to the south the surface of the alluvial fill is level. Thus, the Late Sangamon pediment descends longitudinally along the axes of the present interfluvium to a Late Sangamon valley-slope alluvial fan which in turn merges with a discontinuity of surface slope to Late Sangamon flood-plain alluvium. The Late Sangamon flood plain now stands 17 feet above the modern flood plain of North Turkey Creek.

It should be noted that there is a constancy of slope (3.3 percent) of the pediment and surface of the valley-slope alluvial fan. This suggests that pedimentation progressed with a concurrent rising base level to which the pediment was graded. Howard (20, p. 8) has noted that pediments occur in regions of rising, stationary, or lowering base levels.

Along the interfluvium C to B (fig. 45; pl. IV: C.95, 5.85-B.2, 2.1) from the present valley-slope shoulder a paleosolic surface extends northward from station 880 N to station 1,280 N (fig. 48), a distance of 400 feet and rises from 1,303 to 1,307 feet or on a 1 percent slope. The paleosol, overlain by thin Wisconsin loess, is formed in bedded silts, sands, and gravels. Deep borings, penetrated the alluvium so that a stone line on till is known to occur at a depth of 9 feet below the paleosol surface at station 1,280 N. Thus, the base of the alluvium rises northward on a slope of 3.8 percent in contrast to the 1 percent slope of the surface of the fill. This is the Late Sangamon flood plain and subjacent valley-fill alluvium.

From station 1,280 N to station 1,770 N the paleosolic surface rises northward on a 3.2 percent slope. The paleosol is formed in bedded sands and gravels that overlie a stone line on till. The stone line between the same stations rises northward on a 6.8 percent slope and at station 1,770 N merges with the stone line on the Late Sangamon pediment overlain by thin pedi-sediment and thin Wisconsin loess. Between these two stations the paleosolic surface and subjacent alluvium are the Late Sangamon valley-slope alluvial fan.

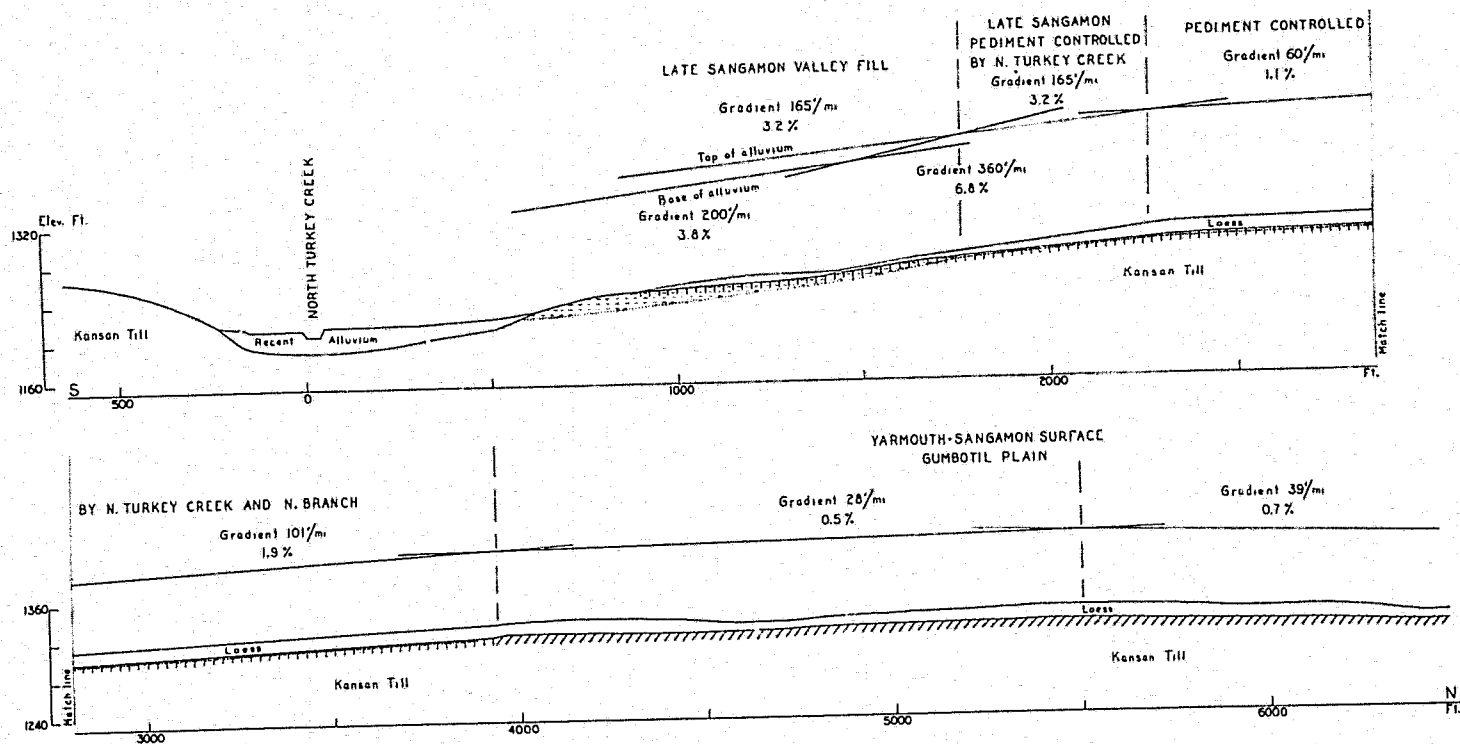

FIGURE 48.—Geomorphic profile along axis of interfluvium north of North Turkey Creek (fig. 45, C-B; pl. IV: D.15, 6.55-B.35, 2.25).

From station 1,770 N to 2,270 N the pediment rises northward on a 3.2 percent slope that is continuous with the 3.2 percent slope of the valley-slope alluvial fan. This constancy of slope also indicates that pedimentation progressed with a concurrent rising base level in the main valley to which the pediment was graded.

From station 2,270 N the pediment slope flattens to 1.1 percent and then increases to 1.9 percent and rises to the level of the Yarmouth-Sangamon surface. The changes in slope of the pediment surface probably were caused by grading of the pediment to a secondary directrix, North Branch (pl. IV). It will be noted that relict pediment surfaces occur along the interfluves peripheral to North Branch and below the Yarmouth-Sangamon surface. The relict pediment surfaces slope toward North Branch (pl. IV, fig. 45).

The Late Sangamon flood plain stands 18 feet above the modern flood plain along North Turkey Creek (fig. 48). The base of the Late Sangamon valley-fill alluvium stands 17 feet above the base of the Recent valley fill in the valley of North Turkey Creek.

Side-valley fill and pediment. Transverse to the axes of the present interfluves the Late Sangamon pediment generally is slightly convex upward (fig. 49). For example, along State highway 25 (fig. 45, F-G; pl. IV: H.60, 4.35-H.60, 2.35; fig. 49) not only is the convexity of the pediment displayed, but the convex summit drops off in concave slopes to an alluvial fill in the adjacent side valley.

At station 528.4 (fig. 49) the stone line is at its maximum elevation of 1,291 feet, and is overlain by thin pedi-sediment and thin Wisconsin loess. At station 526.5, which is 190 feet south, the stone line has sloped convexly to an elevation of 1,285 feet, a slope of 3.1 percent. At station 526.5 the stone line passes under a gray, gleyed, massively bedded alluvial sediment that is alternately silty clay and clay loam texture. The stone line continues to slope southward at 3.1 percent under the gray alluvium. At station 524.5 approximately 8½ feet of gray alluvium overlie the stone line. However, from station 526.5 to station 524.5 the top of the alluvium is level. The convex summit of the pediment surface, including the pedisediment veneer, stands only 5 feet above the surface of the side-valley alluvium. Thus, in a linear distance of 390 feet there is only 5 feet of relief. The pedi-sediment merges laterally on the pediment surface with side-valley alluvium.

Thus, not only was sediment, derived during pedimentation, carried downward across the pediment and deposited in controlling main stream valleys (traverses A-B, C-B) but also was carried laterally across the pediment and deposited in small side-valley waterways that were emplaced on the pediment surface. The question is now answered as to what happened to the volumes of sediment derived during the course of pedimentation. Then too, here is evidence that erosion and sedimentation took place in at least two directions on the pediment surface.

Paleosols. The paleosols of the Late Sangamon pediment differ somewhat from those of the Late Sangamon valley-slope fan,

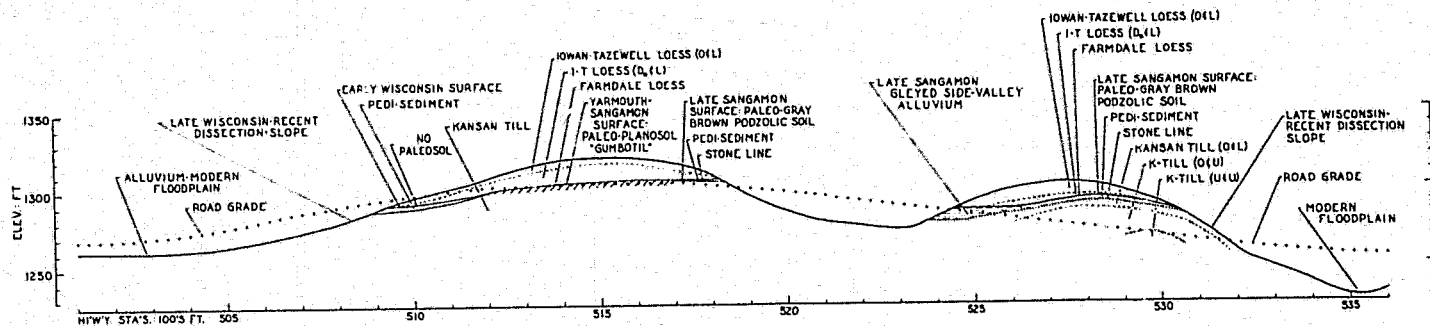

FIGURE 49. Relationship of Late Sangamon pediment to its side-valley alluvial fill in direction transverse to longitudinal axis of present interfluvium.

which in turn differ from the paleosols of the Late Sangamon flood plain. A paleosol of the pediment has the following morphology:

Section I (pl. IV: C. 65, 4.15):

0-56 inches	Tazewell loess with modern soil in upper part.
1A _{1b}	Dark brown (10YR 4/3) silt loam; weak fine to medium platy; friable; leached Farmdale loess.
56-71 inches	
11A _{2b}	Yellowish brown (10YR 5/4) gritty silt loam; weak fine subangular blocky; friable; weatherable minerals visible; leached Late Sangamon pedi-sediment.
71-80 inches	
11B _{2b}	Yellowish brown (10YR 5/4) gritty silty clay loam; moderate medium subangular blocky; firm; clay skins sparse; weatherable minerals visible; leached Late Sangamon pedi-sediment; band of gravelly loam at lower boundary; leached Late Sangamon stone line.
80-88 inches	
111B _{2b}	Dark brown (10YR 4/3) gritty clay; mottled with yellowish brown (10YR 5/4) and red (2.5YR 4/6); strong medium subangular blocky; compact, plastic; clay skins abundant; weatherable minerals visible; leached Kansan till.
88-102 inches	
111B _{2b}	Strong brown (7.5YR 5/8) gritty clay loam; mottled with brown (7.5YR 5/2); moderate medium subangular blocky; firm; clay skins common, concentrated in vertical tubules in lower part of horizon; weatherable minerals visible; leached Kansan till.
102-112 inches	
111C _{1b}	Yellowish brown (10YR 5/6) gritty clay loam; mottled with light brownish gray (10YR 6/2) and light gray (10YR 7/2); coarse angular blocky; firm; weatherable minerals visible; oxidized and leached Kansan till.
112-133 + inches	

This paleosol is similar morphologically to modern Gray-Brown Podzolic soils and is similar also to profile H. Profile H is on the well-aerated and well-drained Late Sangamon pediment above the valley-slope fan.

On the Late Sangamon valley-slope fan a paleosol has the following morphology:

Section K (pl. IV: D.8, 4.9):

A _p	Very dark grayish brown (10YR 3/2) gritty loam; weak fine granular; friable; weatherable minerals visible; leached Late Sangamon fan-alluvium, boundary to lower horizon sharp.
0-6 inches	
PA ²⁰	Dark yellowish brown (10YR 4/4) gritty loam; moderate fine platy; friable; weatherable minerals visible; leached Late Sangamon fan-alluvium.
6-9 inches	
PB ₁	Dark yellowish brown (10YR 3.5/4) gritty loam; weak medium subangular blocky; firm; clay skins moderate; weatherable minerals visible; leached Late Sangamon fan-alluvium.
9-15 inches	
PB ₂₁	Reddish brown (2.5YR 4/4) gritty heavy clay loam; mottled with dark yellowish brown (10YR 4/4) and dark grayish brown (10YR 4/2); strong medium subangular blocky; firm but plastic; clay skins abundant on aggregate faces and in vertical root tubules ½ to 1 inch in diameter; weatherable minerals visible; leached Late Sangamon fan-alluvium.
15-25 inches	
PB ₂₂	Reddish brown (2.5YR 4/4) gritty clay loam; mottled with yellowish brown (10YR 5/6), dark yellowish brown (10YR 4/4), and dark grayish brown (10YR 4/2); strong medium subangular blocky; firm but plastic; clay skins abundant on aggregate faces and in large root tubules; weatherable minerals visible; leached Late Sangamon fan-alluvium.
25-32 inches	

²⁰ The upper case P preceding a major horizon designation indicates that a paleosol is exposed on the modern surface. Exhumed paleosols, in most cases, are foreign to the modern environment, so that the standard nomenclature (A-B-C) with its inherent genetic bias would imply incorrectly that the paleosol had developed on the modern surface. In this profile a modern A_p has developed in a paleosol A_p horizon (55).

PB ₁ 32-44 inches	Yellowish red (5YR 5/6) gritty light clay loam; mottled with yellowish brown (10YR 5/6) and dark yellowish brown (10YR 4/4); moderate medium subangular blocky; firm; clay skins common on aggregate faces and dominantly in large vertical tubules in lower part of horizon; weatherable minerals visible; leached Late Sangamon fan-alluvium.
PC 44-56 inches	Yellowish brown (10YR 5/8) gritty loam; mottled with yellowish red (5YR 5/8) and gray (10YR 5/1); massive; friable; weatherable minerals visible; leached Late Sangamon fan-alluvium.
PD ₁ 56-92 inches	Yellowish brown (10YR 5/8) gravelly sandy loam; massive but bedded; friable; weatherable minerals visible; leached Late Sangamon fan-alluvium; basal layer is stone line.
PD ₂ 92+ inches	Yellowish brown (10YR 5/8) gritty clay loam; coarse angular blocky; firm; oxidized and leached Kansan till.

This paleosol also is similar morphologically to modern Gray-Brown Podzolic soils. The large clay-lined tubules attest to development under forest vegetation. The paleosol in general is similar to profile I, but it differs in several ways. There is a lesser degree of clay differentiation between the zone of maximum accumulation relative to superjacent and subjacent transitional horizons than in profile I (fig. 50). The solum in profile K is entirely in alluvial material so that a heavier textured till, as in profile I, has not acted as a barrier to downward translocation of clay. As a result in profile K there has been greater distribution of clay through a greater vertical depth range than in profile I.

In profile K the stone line occurs at a depth of 92 inches, 48 inches below the solum; in profile I it occurs in the lower part of the B_w horizon.

Profile K is more intensely weathered than profile I. Clay ratio of the B/C horizons in K is 1.53:1, whereas in I the ratio is 1.39:1. Weathering ratios of the heavy mineral fractions (fig. 50) further

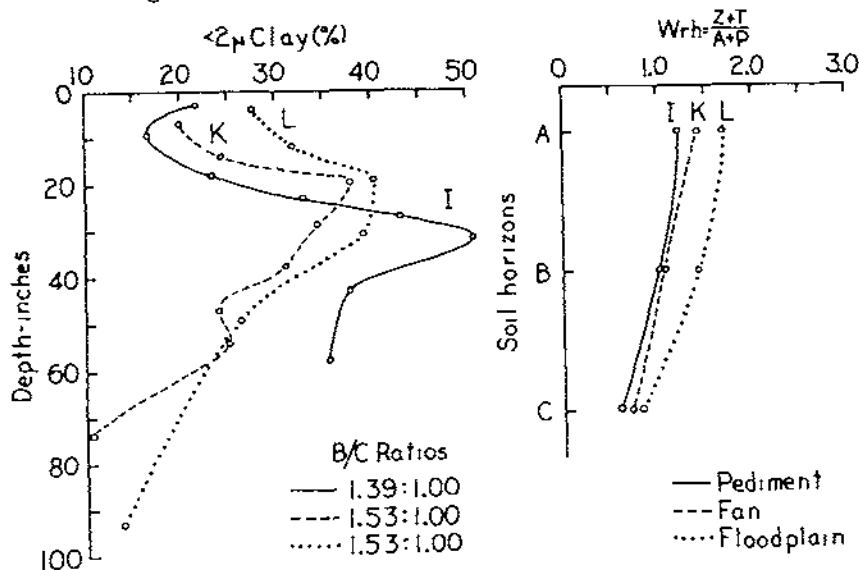

FIGURE 50.—Clay content and weathering ratios of heavy mineral fractions (Wrh) of paleosols of Late Sangamon pediment, valley-slope fan, and flood plain.

indicate more intensive weathering in profile K. The weathering ratio (table 24, Wr_h in the A_2 horizon of K is 1.43:1, but in I it is 1.01:1. In the B horizons the ratios are 1.04:1 and 1.01:1. On the Late Sangamon landscape profile K in the valley-slope alluvium should have occurred in a less well aerated or drained position than profile I on the pediment.

On the Late Sangamon flood plain is a paleosol that has the following morphology:

Section L (pl. IV: C.65, 5.55):

0-42 inches	Tazewell loess with modern soil in upper part.
IA _{1b}	Dark brown (10YR 4/3) slit loam; weak fine platy; friable; leached
42-48 inches	Farmdale loess.
IIA _{2b}	Dark yellowish brown (10YR 4.5/4) gritty light silty clay loam; weak
48-56 inches	coarse platy; firm; weatherable minerals visible; leached Late Sangamon alluvium.
IIB _{1b}	Yellowish brown (10YR 5/4) gritty silty clay loam; sparsely mottled
56-59 inches	with reddish brown (5YR 4/4); moderate fine subangular blocky; firm; clay skins sparse; weatherable minerals visible; leached Late Sangamon alluvium.
IIB _{21b}	Yellowish brown (10YR 5/4) gritty light silty clay; abundantly mottled
59-72 inches	with reddish brown (5YR 4/4); strong medium subangular blocky; firm but plastic; clay skins abundant; weatherable minerals visible; leached Late Sangamon alluvium.
IIB _{31b}	Yellowish brown (10YR 5/6) gritty heavy silty clay loam; mottled
72-86 inches	with light brownish gray (10YR 6/2) and light gray (10YR 6/1); moderate medium subangular blocky; firm and plastic; clay skins abundant; weatherable minerals visible; leached Late Sangamon alluvium.
IIB _{3b}	Yellowish brown (10YR 5/6) gritty loam; mottled with light brownish
86-124 inches	gray (10YR 6/2) and light gray (10YR 6/1); coarse subangular blocky; firm; clay skins common but oriented in vertical tubules in lower part of horizon; weatherable minerals visible; leached Late Sangamon alluvium.
IIC _{1b}	Strong brown (7.5YR 5/6) sandy loam; stratified; friable; leached Late
124-165+ inches	Sangamon alluvium.

A stone line at the base of the alluvium occurs at a depth of 200 inches and overlies a clay loam deoxidized and leached till.

The clay distribution in profile L is similar to that in profile K but differs in the same degree as profile K from profile I on the pediment (fig. 50). Profile L differs from the other two in that grayish brown and light gray mottles are common in the lower part of the B_{2b} horizon and continue to depth. Such mottling probably is indicative of the poor aeration and drainage that must have prevailed when the soil occupied a position on the Late Sangamon flood plain. The reddish brown colors in the upper part of the solum are anomalous when contrasted to the gray mottling in the lower part of the solum. The reddish colors probably result from alteration of iron oxides within the solum under conditions of better aeration after the Late Sangamon flood plain had become dissected during Wisconsin time. As a result of such dissection the old bottomland became an upland interfluvium.

The flood-plain paleosol is weathered more intensively than both the valley-slope fan and pediment paleosols (fig. 50). Mineral weathering is progressively more intensive from the better aerated paleosol of the pediment (I) to the less well aerated paleo-

sol of the valley slope fan (K) to the poorly aerated paleosol of the flood plain (L). Thus, there is more intensive weathering toward the wetter members of the catena.³⁰

In this regard, mineral weathering in Late Sangamon paleosols is similar to the weathering in Yarmouth-Sangamon paleosols where more intensive mineral decomposition was noted in the wetter soils.

Late Sangamon valley-slope fan and flood-plain paleosols that crop out on the modern surface may be classed as variants of the Adair series.

EVOLUTION

The Late Sangamon surface occurs below the Yarmouth-Sangamon surface and is paired across and peripheral to main, tributary, and side drainages (pls. II, IV). In many places the Late Sangamon surface rises curvately concave-upward to the older Yarmouth-Sangamon surface (fig. 40). The Late Sangamon surface, marked by a stone line, is cut in Kansan till, which is the same material that overlies the Yarmouth-Sangamon upland (fig. 40). The Late Sangamon surface is mantled by a thin veneer of alluvial sediment (pedi-sediment). These characteristics fulfill Howard's descriptive requirements of a pediment.³¹

The Late Sangamon surface cannot be considered a bench if Tator's³² definition is accepted. Thus, the Late Sangamon erosion surface is considered to be a pediment.

The Late Sangamon pediment is graded downslope, in directions away from the Yarmouth-Sangamon upland, to valley-slope

³⁰ *Catena* is used in the sense of Milne's (87, pp. 16-17) definition:

"... the distribution of soil types is a function of local difference of level and slope, which govern drainage. . . .

A sequence of this kind is termed a catena, or catenary complex. . . .

Two variants of the catena can be distinguished. . . . In one, the topography was modelled, by denudation or other process, from a formation originally similar in lithological character at all levels at which it is exposed. Soil differences were then brought about by drainage conditions, differential transport of eroded material, and leaching, translocation, and redeposition of mobile chemical constituents. . . . In the other variant, the topography was carved out of two or more superposed formations which differ lithologically, of which the uppermost now forms a capping on hill tops and ridges, while the lower ones are exposed successively down the slopes. In such circumstances we may have a soil succession catenary in form but with a geological factor added to the other conditions making for soil differences. . . ."

The Late Sangamon paleosol catena conforms to Milne's catena, first variant.

³¹ Howard (20, p. 8) has placed certain limitations in his definition of pediment that can be measured only with extreme difficulty. The limitations are italicized in the following definition: ". . . that portion of the surface of degradation at the foot of a receding slope which is underlain by rocks of the upland and which is either bare or mantled by a layer of alluvium *not exceeding in thickness the depth of stream scour during flood*, is essentially a surface of transportation *experiencing neither marked vertical downcutting nor excessive deposition*, and displays a longitudinal profile normally concave, but which may be convex at its head in later stages of development."

³² Tator (69, p. 52) states: "Thus, narrow planate surfaces restricted by recognizable valley walls are benches."

fans and valley-fill alluvium. The pediment grades laterally to alluvial fills of side valleys emplaced on the pediment surface.

Process. With the characteristics of the Late Sangamon pediment and its relationship to valley fills and the Yarmouth-Sangamon surface defined, it is possible to reconstruct a process of evolution that best fits the field and laboratory evidences.

A surface (fig. 51, A: A-B-D-Q-C), such as the weathered Yarmouth-Sangamon relict till plain, is incised by a stream system. The system may be: (1) main stream (A-B) and tributaries (G-C and K-D), (2) tributary (A-B) and side streams (G-C and K-D), or (3) combinations of lower order streams of a system. In South and North Turkey Creek areas (pls. II, IV) the combinations are both main and tributaries and tributary and side streams.

With incision of the streams three elements of the landscape are evolved—the valley bottom, the valley slope, and the level to undulating upland. Geomorphic profiles of the landscape at this stage are simple. Valleys are cut below the weathered rind of the upland (fig. 51; A: E-Q, O-P). Weathering and pedogenesis progress on the upland; the surface, being level or undulating, cannot be eroded because of a minimum of runoff to the drainage-ways. Wash processes on the upland may result in local transport of fine sediment to adjacent upland swales, but in no way is such local wash related to the incision cycle. Ultimately the swales fill to the level where adjacent slopes and swell crests stabilize. The weathered rind of the upland forms.³³ It is not possible to conjecture that the upland is eroded and lowered such as is postulated by Davis (11, pp. 254, 255) and more recently by Holmes (19, p. 387).

Of the three elements of the landscape the valley slope has greatest declivity and is most susceptible to erosion. In the interfluvium of homogeneous composition (till) and defined on three sides by streams, erosive processes may attack normal to the valley walls. Thus, at any place along the main valley A-B (fig. 51, A) erosion may progress as from E to F. At any place along side stream G-C, erosion may progress as from I to J; along side stream K-D, as from M to N. Thus, at any place between vectors E-F and I-J erosion may progress as along a resultant G-H; and between vectors E-F and M-N erosion as along a resultant K-L. Erosion by minor streams is attacking an interfluvium on the present landscape in such a manner (pl. III: C-8, 4.7-E.4, 5.3).

As the longitudinal profile of any stream in homogeneous material is concave upward with progressively decreasing slope

³³ The proof of these statements may be found in an examination of the Boone quadrangle topographic sheet (36) and the Boone County, Iowa, soil map (40). In this area the Des Moines River has incised the Cary till plain to depths of more than 300 feet. In southern Dodge Township, Poor Farm Branch, a main tributary of Des Moines River, is extending headward into the Cary till plain. But on the Cary till plain are many closed, undrained depressions, peat and muck bogs, and swamps. Clarion, Nicollet, and Webster soils are developing on the upland surface. The main problem in these soils is not erosion but drainage.

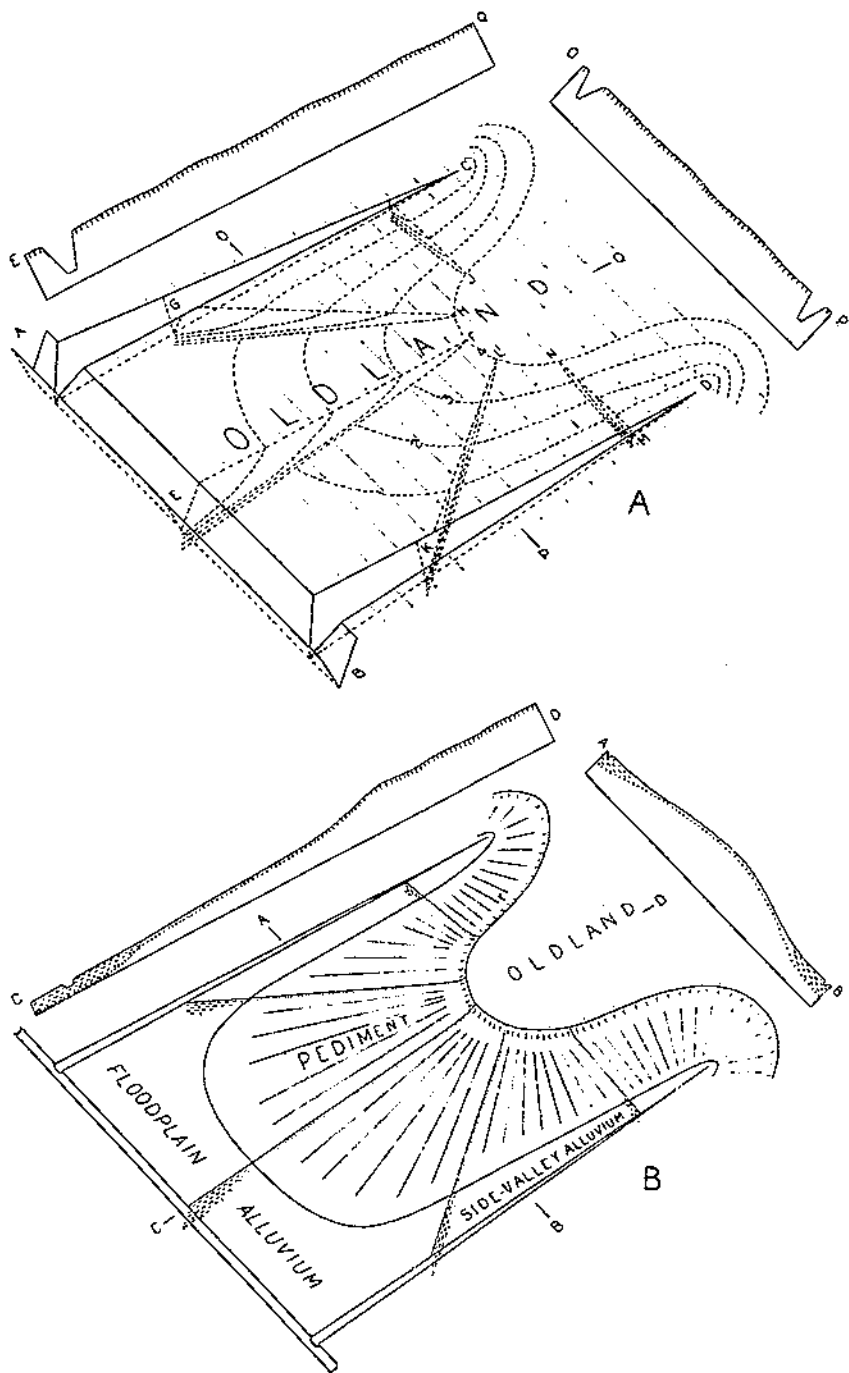

FIGURE 51.—Evolution (diagrammatically) of Late Sangamon pediment, valley-slope fan, and flood plain.

downstream, the datum surface bounding each side of the interfluvium will have such configuration. A subsequently evolved erosional landform must conform to the datum configuration. The many minor streams attacking the valley slopes also have concave profiles (cf. pl. III). Bryan (8, pp. 91-92) termed such erosion "gully-gravure." Undoubtedly, mass wasting and wash processes also are effective in the interstream areas.

The multidirectional attack on the valley slopes will cause the upland shoulder to recede progressively (fig. 51, A: 1-2-3-4) both toward the axis of the interfluvium (E-Q) and toward the upland divide (Q). As long as the upland remains broad enough so that infiltration of rainfall exceeds runoff, the upland will remain uneroded but will be subjected to weathering.

The many stream systems encroach headward and ultimately breach the interfluvium summit (E-Q). The weathered rind of the summit is eroded. The relict upland surface, however, is preserved on the upland divide (fig. 51, B). Below the oldland a new cyclic surface, the fourth element of the landscape (pediment), has evolved, and a new landscape surface is available for a new cycle of pedogenesis. During the formation of the younger surface, erosion of the till results in a concentration of lag gravel (stone line) on the till surface. Sediment from upslope is transported across the pediment and deposited in the main valley and valley-slope fan and as pedi-sediment on the pediment itself (fig. 51, B: C-D). Such geomorphic relationships were shown in the North Turkey Creek area (figs. 47, 48). Sediment from upslope also is transported laterally across the pediment and deposited in side valleys and as pedi-sediment on the pediment itself (fig. 51, B: A-B).³¹ Such geomorphic relationships also were shown in the North Turkey Creek area (fig. 49).

Thus, the end result of the process of pediment erosion is an upland surface, characterized by deep, intensively weathered soils, that is geographically juxtaposed to but separated from a younger, lower cyclic surface by geomorphic, pedologic, and mineralogic unconformities (fig. 40). If the upland had been subject to downwearing concurrent with but at a slower rate than stream incision as advocated by Davis (11, p. 254-255) and Holmes (19, p. 387), the geomorphic, pedologic, and mineralogic unconformities that are delineated sharply on the landscape would not exist. If the downwearing concept were valid, erosion should progress with grading of the slopes from the divides to the streams such that erosion would be the equivalent of or subordinate to concurrent weathering. Otherwise, deep, intensely weathered soils would develop on divides only after base leveling. If such is the case, there should be little significant difference of soils in catenary association. The occurrence of the unconformities on the landscape invalidate the latter concept and support the process of pedimentation.

³¹ The transverse profile across the pediment (fig. 51, B: A-B) is convexo-concave. A convexo-concave surface is the geometric resultant of the angular coalescence of two or more concave surfaces.

The kind of landscape and the process involved in its evolution in subhumid Iowa do not differ greatly from the kind of landscape or the process involved in its evolution in humid, tropical Africa (49, pp. 64-74). Apparently pedimentation is the "normal" process of landscape evolution in humid areas.

From the standpoint of soil landscapes, the field evidence indicates that an upland surface remains little modified by erosion, but is subjected to intensive weathering. A lower, younger, cyclic surface encroaches on the upland and, in doing so, strips the weathered products of the upland surface and exposes a fresh landscape to a new cycle of pedogenesis. Thus, depending upon the environment, the different kinds of soils of the lower, younger surface with their different morphological and mineralogical properties may be adjacent to the soils of the old weathered rind of the upland.

Early Wisconsin Surfaces

Two surfaces of Early Wisconsin age occur in the Greenfield quadrangle. One surface is high on the landscape on the upland divide and along the summits of interfluves. This surface is the top of the Tazewell loess that has not been subjected to post-loessial erosion.

The other surface is low in the landscape, on the interfluves, and is the low level of the stepped surfaces. This surface is the Early Wisconsin pediment.

LOESS UPLAND

Distribution and characteristics. The upland surface of Tazewell age is on the loess of the divides in the South Turkey Creek area (pl. II: C.20, 5.10-C.30, 3.95; B.55, 3.80-B.65, 1.45; B.65, 1.45-E.40, 1.20; I.40, 7.00-1.75, 3.90) and on the summits of interfluve ridges (pl. II: C.55, 4.65-D.80, 5.00; G.25, 5.50-1.35, 6.55). It is dominantly level (fig. 52) but in some places has slopes of 1 to 2 percent. It overlies the complete weathering zonation in the Wisconsin loess (fig. 34) that is a part of a regional distribution in southwestern Iowa.

Four lines of evidence show that the upland surface of Tazewell age is stable: (1) The complete weathering zonation, part of the regional developmental sequence, underlies it on the upland divides and level to slightly rounded interfluve summits. At other places in the area (pl. II: E.15, 3.80; H.7, 4.3) the sequence of the weathering zones is not complete; the upper part is missing, which indicates that truncation has occurred.

(2) It is parallel to and does not truncate the weathering zonation of the loess. Thus, it must have been emplaced during the development of the weathering zonation. If the surface angularly beveled the weathering zonation, it would be subsequent to zonation development.

(3) It is generally parallel to and does not truncate the Pleistocene succession of deposits or geomorphic surfaces and is of depositional configuration. If it angularly beveled the Pleistocene succession of deposits and geomorphic surfaces, it would be



FIGURE 52.—Level loess upland of Tazewell age.

younger than the youngest beveled deposit or surface. Thus, the upland surface is the one produced after deposition of the youngest deposit, Tazewell loess, ceased.

(4) Its slopes (0 to 2 percent) are of such slight gradient as to preclude significant erosion. Infiltration of rainfall undoubtedly is dominant over runoff.

From this evidence it can be concluded that the level upland surface on loess has been stable since cessation of loess deposition during Tazewell time. Alteration of materials on the surface by weathering and pedogenic processes date from that time.

Age of loess-upland surface. The level Tazewell upland surface can be traced northward throughout the Greenfield quadrangle and farther northward to the margin of the Cary drift border (fig. 53), which is located less than 10 miles north of the north-east corner of the quadrangle.

At the margin of the Des Moines lobe the Tazewell loess passes under the Cary drift. At two sections, Mitchellville (fig. 53, A) and Clear Creek (B), and deep within the buried Tazewell loess, logs of hemlock and spruce were buried. At Mitchellville the wood was 17 feet below the top of the buried loess (51, p. 83-84). The wood has been dated by radiocarbon analysis at $16,720 \pm 500$ years and $> 17,000$ years (53, p. 265). At Clear Creek the hemlock logs were $12\frac{1}{2}$ feet below the top of the buried Tazewell loess (51, p. 84-88). The wood has been dated at $14,700 \pm 400$ years and $16,367 \pm 1,000$ years (53, p. 265). This stratigraphic evidence indicates that Tazewell loess was being deposited in central Iowa 14,700 to more than 17,000 years ago. Undoubtedly Tazewell loess was accumulating on the uplands in the Greenfield quadrangle at the same time.

At two sections, Scranton 1 (fig. 53, I) and Scranton 2 (H), paleo-Regosols developed in the uppermost parts of the Tazewell loess (54, p. 680-685). The Scranton 2 section has an A₁ horizon

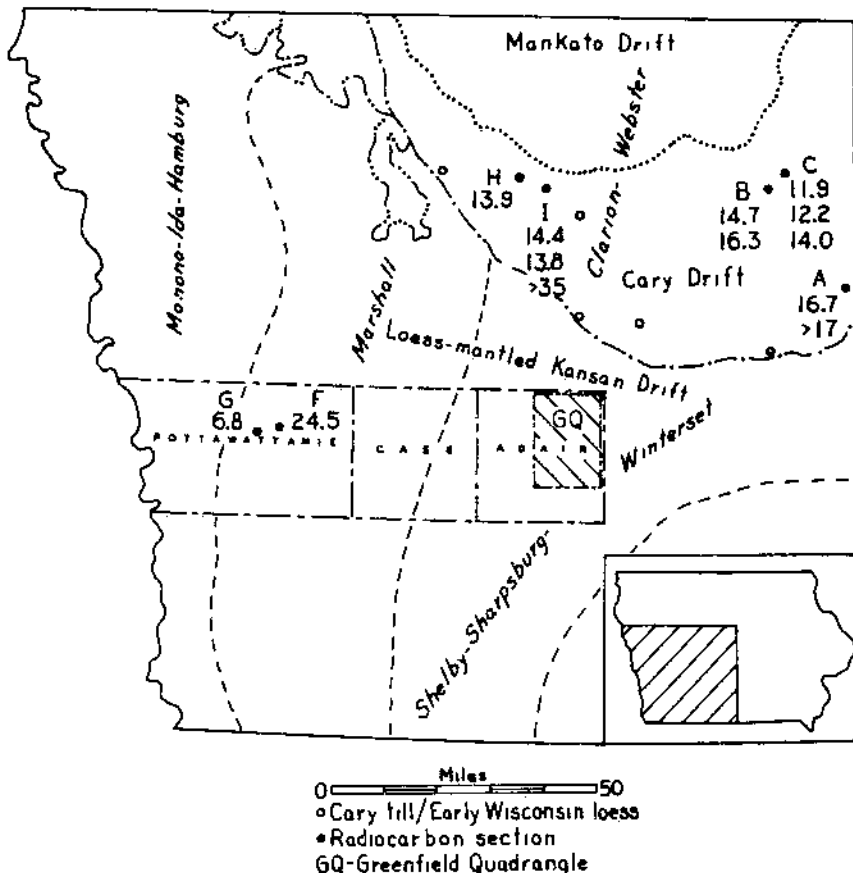

FIGURE 53.—Relationship of Greenfield quadrangle (GQ) to radiocarbon sections of Des Moines lobe, Cary and Mankato drifts. Monona-Ida-Hamburg, Marshall, Shelby, Sharpsburg-Winterset are soil association areas.

12 inches thick in the uppermost part of the buried loess. The loess is leached of carbonate to a depth of 19 inches. The buried soils are overlain by Cary till. Spruce trees rooted in place in the buried soils have been dated at $13,910 \pm 400$ years and $14,470 \pm 400$ years, respectively. This shows that Tazewell loess deposition had ceased and soil formation had begun some 14,000 years ago. Undoubtedly the same loessial soil history was occurring to the southward in the Greenfield quadrangle.

Uneroded Tazewell-loess uplands should date from that time and in the Greenfield quadrangle are considered to be 14,000 years old.

Soils of the Sharpsburg series developed on the loess of the Tazewell upland.

PEDIMENT

Distribution and characteristics. The low level of the stepped sequence of surfaces along the interfluvies is the Early Wisconsin

pediment that is cut into Kansan till below the Late Sangamon and Yarmouth-Sangamon surfaces (pls. II, IV). Along an interfluvial axis in the South Turkey Creek area (pl. II: F.85, 4.50-F.40, 1.65) the stepped sequence has three levels above the modern flood plain (fig. 54). The level summit of the low surface stands 40 feet above the modern flood plain. Along the axis of the interfluvial the summit rises 4 feet in a distance of 430 feet to the northward, a slope of less than 1 percent. The surface then rises 10 feet up a concave slope in a distance of 230 feet to the northward, or on a slope of 4.4 percent, to the level of the Late Sangamon surface (fig. 54). The surface of less than 1 percent slope is the footslope of the Early Wisconsin pediment, and the part of the surface with a steeper slope is the backslope of the Early Wisconsin pediment. The geomorphic relationship of the Early Wisconsin pediment to the Late Sangamon pediment (fig. 54) is similar to the relationship of the Late Sangamon pediment to the Yarmouth-Sangamon surface (fig. 40). Along the interfluvial (fig. 54) the Late Sangamon pediment rises northward to the level of the Yarmouth-Sangamon upland divide.

The three surfaces are separated by geomorphic, pedologic, and mineralogic unconformities (fig. 54). On the lowest Early Wisconsin surface the modern Brunizem, Shelby loam, formed in Kansan till. The Brunizem is weakly developed and not intensively weathered mineralogically (48, p. 452-454), whereas the Late Sangamon paleo-Gray Brown Podzolic soils and the Yarmouth-Sangamon paleo-Planosols and paleo-Humic Gleys are progressively better developed and more intensively weathered mineralogically.

The footslope-backslope relationship of the Early Wisconsin pediment to the Late Sangamon pediment is well displayed along an interfluvial of West Branch (pl. II: E.25, 3.15-E.25, 3.65). The footslope of the Early Wisconsin pediment now stands 30 feet above the modern flood plain of West Branch (fig. 55, A). The footslope rises 5 feet in a distance of 325 feet to the southward, a slope of 1.5 percent. The surface then rises up a concave back-slope 20 feet in a distance of 160 feet (a 12.5 percent slope) to the level of the Late Sangamon pediment.

The footslope of the Early Wisconsin surface is mantled by a stone line that locally is covered by a few inches of pedi-sediment (fig. 55, A). The modern Brunizem, Shelby loam, is on this surface, whereas the higher intermediate level Late Sangamon surface is characterized by paleo-Gray Brown Podzolic soils that are more intensively developed morphologically and more intensively weathered mineralogically.

In places the Early Wisconsin pediment is juxtaposed geomorphically to the Yarmouth-Sangamon surface without an intervening Late Sangamon surface. Along the axis of an interfluvial adjacent to West Branch (pl. II: D.10, 3.25-C.75, 3.55) the Early Wisconsin pediment stands 35 feet above the modern flood plain of West Branch (fig. 55, B). The footslope of the pediment rises 4 feet in a distance of 225 feet to the southward, a slope of 1.8 percent. The pediment then rises 17 feet in elevation up a con-

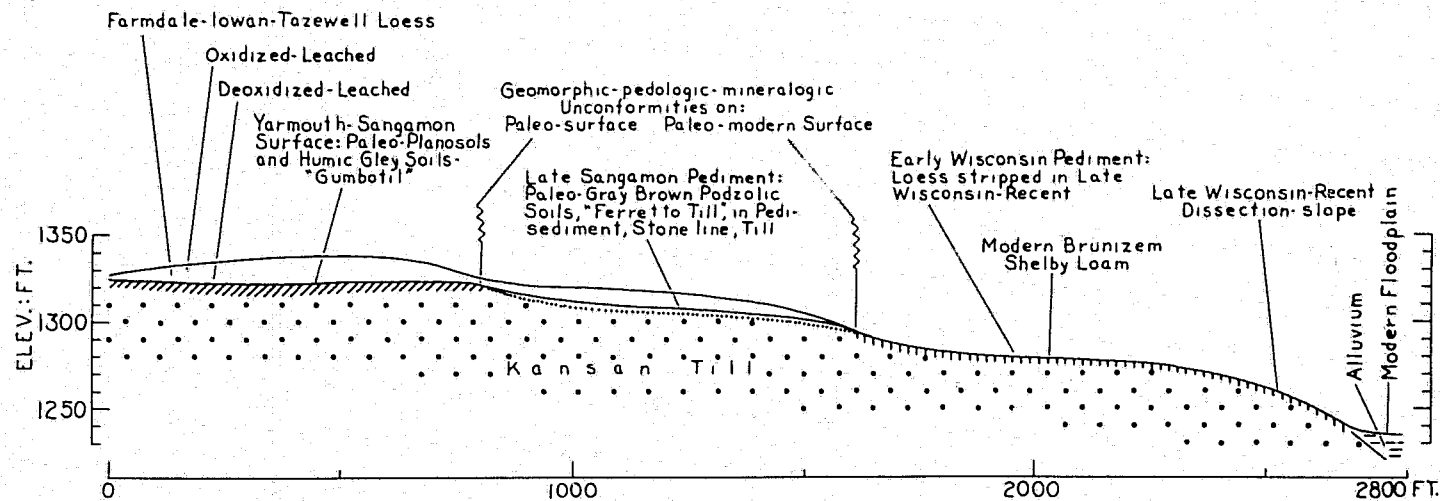

FIGURE 54.—Threefold stepped sequence of levels along interfluvium in South Turkey Creek area (pl. II: F.85, 3.70–F.40, 1.60).

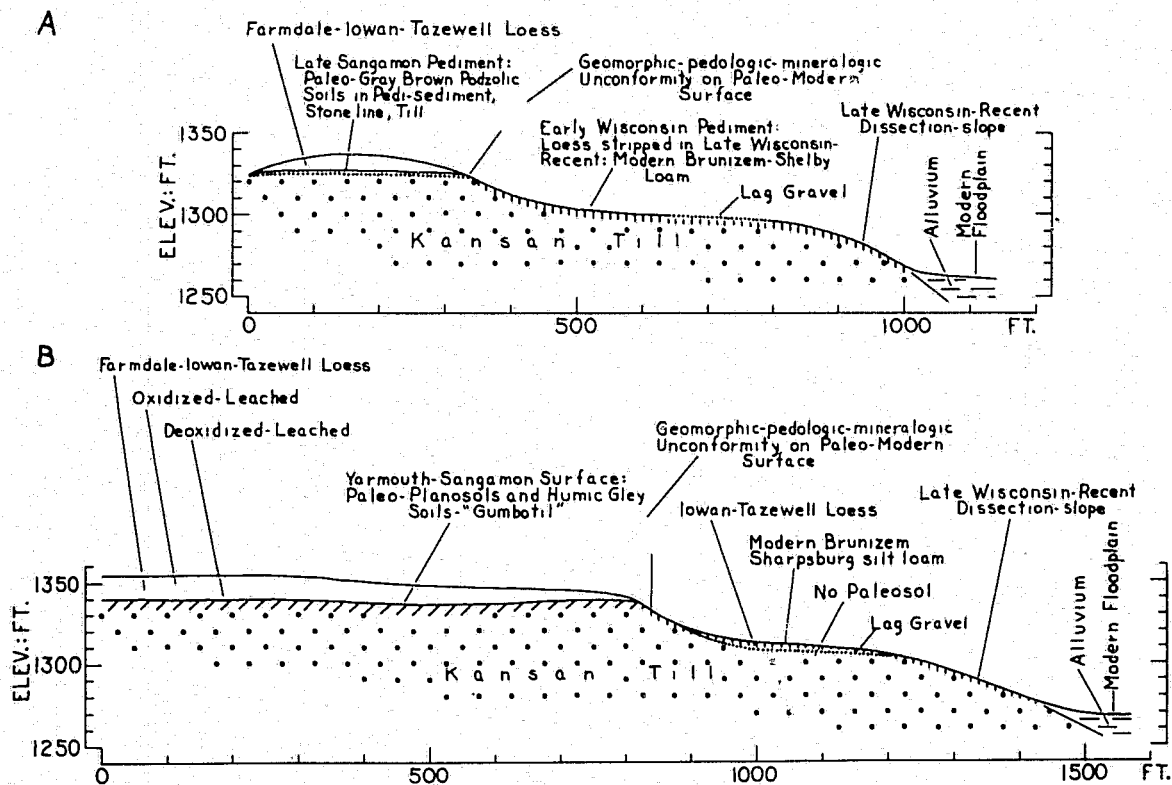

FIGURE 55.—Relationship of Early Wisconsin pediment to Late Sangamon pediment (A; pl. II: E.25, 3.15–E.25, 4.05) and to Yarmouth-Sangamon surface (B; pl. II: D.10, 3.25–C.50, 4.00).

cave backslope (a slope of 17.2 percent) to the level of the Yarmouth-Sangamon surface.

The Early Wisconsin pediment lies on both sides of the main stream and on both sides of the major tributaries in the South Turkey Creek area (pl. II) and on interfluves around the main drainage of a watershed (pl. II: West Branch; pl. IV: North Branch). The geographic distribution of the Early Wisconsin pediment relative to the Late Sangamon and Yarmouth-Sangamon surfaces is similar to the distribution pattern of the Late Sangamon pediment relative to the Yarmouth-Sangamon surface.

The Early Wisconsin surface now occurs on the interfluves in a dissected terrain above the modern flood plain but below the Late Sangamon and Yarmouth-Sangamon surfaces. It is cut in Kansan till, the same material that underlies the upland. Along the present interfluves it has a concave-upward longitudinal profile (figs. 54, 55). In some places it is mantled by a lag gravel and an alluvial veneer. It has a footslope of low gradient and then rises more sharply up a backslope (the receded slope). It not only fulfills the physiographic requirements of a pediment (20, p. 8) but also has the same physical characteristics as the Late Sangamon pediment. Thus, this Early Wisconsin surface is considered to be a pediment.

Age. The pediment is cut into Kansan till below the level of the Late Sangamon surface and therefore must be post-Late Sangamon.

At some places (pls. II, III: D.10, 3.25-C.75, 3.55) the Early Wisconsin pediment, mantled by stone line and thin pedi-sediment, is capped by Tazewell loess (fig. 55, B), but there is no paleosol in the uppermost part of the till. Along one interfluve (fig. 37), Tazewell loess, mantling the pediment, is leached of carbonates to depths of 82 inches. However, the basal 8 inches and the Kansan till, on which the pediment is cut, are calcareous.

The lack of a paleosol or even a weathered zone at the contact of the till and the overlying Tazewell loess indicates there was not enough time for soil formation in the till between the cutting of the pediment surface and the mantling by the loess. These lithologic and stratigraphic relationships identify the age of the pediment surface as Early Wisconsin. The Early Wisconsin pediment in the Greenfield quadrangle probably is correlative of the Early Wisconsin surface of erosion identified along the regional traverse.

Evolution. The similarity of characteristics of the Early Wisconsin and Late Sangamon pediments indicate that the processes responsible for the evolution of the Late Sangamon surface also must have been active in the development of the Early Wisconsin surface.

It seems probable that while pedimentation was active during Early Wisconsin time, the landscape was under a coniferous forest cover. All of the radiocarbon samples (wood) that have been recovered in southwestern and central Iowa and that date from the Farmdale to post-Cary have been coniferous species. For example, a larch sample of Farmdale age, dated at $24,500 \pm 800$

years (53, p. 265) was found near Hancock, Pottawattamie County, Iowa, 45 miles west of the Greenfield quadrangle.

At Mitchellville and Clear Creek in Polk and Story Counties, Iowa, hemlock and spruce samples of Tazewell age have been dated at $14,700 \pm 400$ years to $> 17,000$ years. These radiocarbon localities are 50 miles northeast of the Greenfield quadrangle.

In the Scranton sections, Greene County, Iowa, located 37 miles north of the Greenfield quadrangle, fir, hemlock, larch, and spruce dated at $13,910 \pm 400$ years and $14,470 \pm 400$ years (54, p. 674) marks the close of Early Wisconsin time.

Thus, when the Early Wisconsin pediment evolved, the landscape probably was under coniferous forest cover.

Where loess remains on the Early Wisconsin pediment, Sharpsburg soils occur; where the loess has been stripped, Shelby, Steinauer, or Shelby-Steinauer intergrades developed in Kansan till.

Late Wisconsin-Recent Complex

The landscape of the Greenfield quadrangle has been subjected to dissection and alluviation in Late Wisconsin-Recent time. Dissection has resulted in the suspension of the older geomorphic surfaces above the modern flood plains and in stepped sequence along the summits of interfluves and on the upland divides. Valley slopes truncate not only Pleistocene deposits as young as Tazewell loess but also older geomorphic surfaces. Thus, the dissection must be younger than Tazewell or Late Wisconsin.

Where the summits are narrow, not only has loess been stripped from the Early Wisconsin pediment but from the Late Sangamon pediment and from the Yarmouth-Sangamon surface as well.

Alluviation has filled the main, tributary, and side-stream bottoms and the side-valley waterways that rest on the valley slopes.

Postcultural erosion and sedimentation are in progress at present on the landscape.

UPLAND DIVIDES AND INTERFLUVE SUMMITS

Exhumed paleosolic surfaces. In the South Turkey Creek area, West Branch and its side streams have incised the landscape so that the streams and intervening valley slopes have encroached on the upland divide. As a result the Yarmouth-Sangamon paleosol is exposed at many places near the shoulder of the valley slope (pl. III: D.50, 3.75-B.75, 3.70; B.90, 1.65-G.1, 2.1; H.55, 6.10-I.5, 6.2-I.15, 5.55).

Here, not only do the slopes bevel the paleosolic surface but they bevel the Tazewell loess above and also the regional weathering zonation in the loess. As has been shown, the weathering zonation is probably Late Wisconsin. Thus, the slopes must be not only post-Tazewell but they must also be post-Late Wisconsin.

Along the interfluve south of West Branch (pl. III: E.45, 3.85-F.15, 3.85), a system of side streams has eroded the north slope of the interfluve, and another system of side streams has eroded the south slope. The interfluve summit has been narrowed to an

average width of 140 feet, which apparently is within the critical limits where runoff is dominant over infiltration. As a result the Tazewell loess has been stripped from the interfluvial summit and the Late Sangamon paleosol has been resurrected in toto.

This is the downwearing aspect of landscape evolution. But it should be noted that downwearing occurs only where the upland surface has been narrowed by the encroachment of the lower, cyclic, receding valley slopes. Here is evidence of the process of pedimentation actively in progress on the present landscape.

Along the same interfluvial to the westward (pl. III: D.60, 3.85–D.85, 3.85) a system of side streams of West Branch has encroached on the north valley slope of the interfluvial and a system of side streams has encroached on the south valley slope. The interfluvial summit has been narrowed to a width of 110 feet, and the surficial Tazewell loess has been stripped from the interfluvial summit so that the Late Sangamon paleosol is exhumed in a saddle along the crest of the interfluvial.

Between the two described areas (pl. III: D.85, 3.85–E.45, 3.85) recession of the north and south valley slopes of interfluvial has not been as active. The interfluvial summit is 480 feet wide, which apparently is beyond the critical limits for dominance of runoff over infiltration. As a result the Tazewell loess has not been stripped and remains as a mantle on the Late Sangamon paleosol surface.

Similar relationships of exposed paleosol surfaces occur throughout the South Turkey Creek area (pl. III).

Exhumed Early Wisconsin pediment. Late Wisconsin-Recent dissection has resulted in the suspension of the Early Wisconsin pediment above the modern flood plains and along the interfluvials as the low level of the stepped sequence of geomorphic surfaces.

In places Late Wisconsin-Recent slopes have encroached on the Early Wisconsin pediment so that the interfluvial summit has been narrowed and the surficial Tazewell loess stripped from the surface (pl. III: H.60, 3.55–H.75, 4.20; E.25, 3.15–E.25, 3.65). Here the level to slightly rounded pediment surface on Kansan till was exposed for soil development in Late Wisconsin-Recent time. A soil profile (fig. 56) of this kind is (pl. III: H.6, 3.6):

Section M (pl. III: H.6, 3.6):

A _p	Very dark gray (10YR 3/2) heavy loam; weak medium granular friable; gritty and pebbly with weatherable minerals visible; leached Kansan till.
A ₁ B ₁	Dark brown (10YR 4/3) light clay loam; weak medium subangular blocky; friable; sparse clay skins on aggregate faces; gritty and pebbly with weatherable minerals; leached Kansan till.
B ₂	Dark brown (10YR 4/3) clay loam; moderate medium subangular blocky; clay skins common on aggregate faces; weak plastic; gritty and pebbly with weatherable minerals; leached Kansan till.
B ₃	Dark yellowish brown (10YR 4/4) light clay loam; coarse angular blocky; firm; sparse clay skins; gritty and pebbly with weatherable minerals; leached Kansan till.
C ₁	Yellowish brown (10YR 5/8) light clay loam; coarse angular blocky; firm; gritty and pebbly with weatherable minerals; leached Kansan till.
C ₂	Light yellowish brown (10YR 6/3) loam; coarse angular blocky; firm; carbonate concretions; gritty and pebbly with weatherable minerals; calcareous Kansan till.

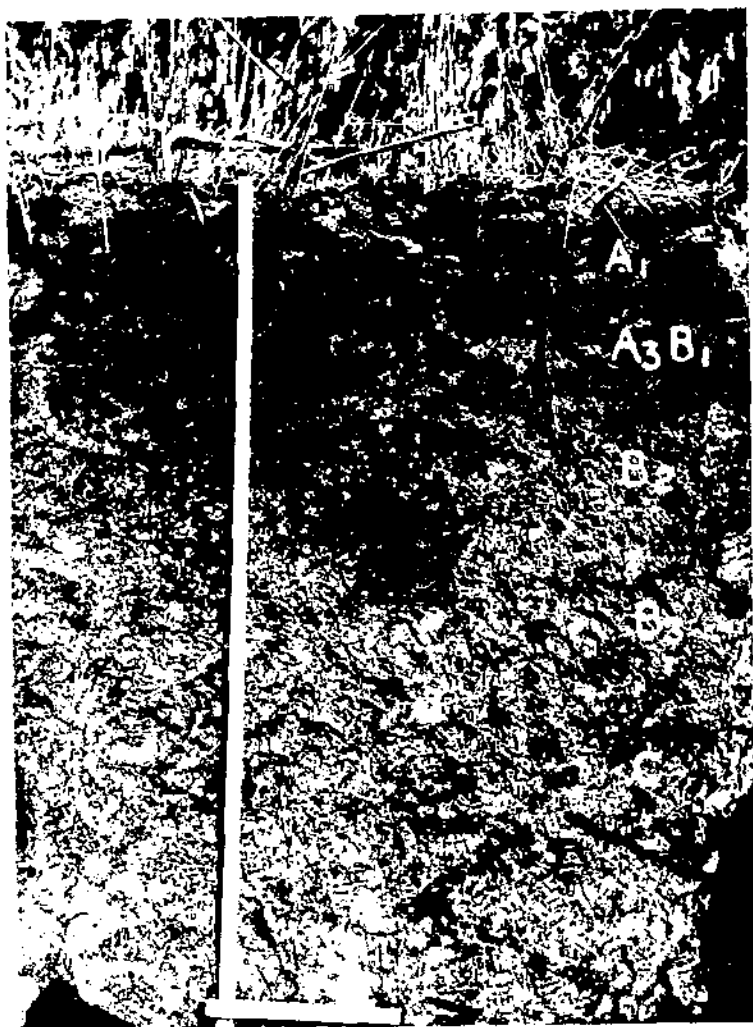

FIGURE 56.—Brunizem, Shelby loam, of Late Wisconsin-Recent age developed in Kansan till on Early Wisconsin pediment.

Two other profiles (fig. 57, N, O) of similar soils on the exhumed Early Wisconsin pediment have similar morphologies but differ slightly in depth of the carbonate horizon. The textural profiles of these soils are somewhat similar in distribution but differ slightly in degree of differentiation (48, p. 452).

For comparison with the Late Sangamon (fig. 44) and Yarmouth-Sangamon (fig. 38) paleosols, the mineralogical-analytical technique was applied to the soils of the exhumed Early Wisconsin pediment. On all three surfaces the soils developed in Kansan till but on surfaces of different geomorphic ages.

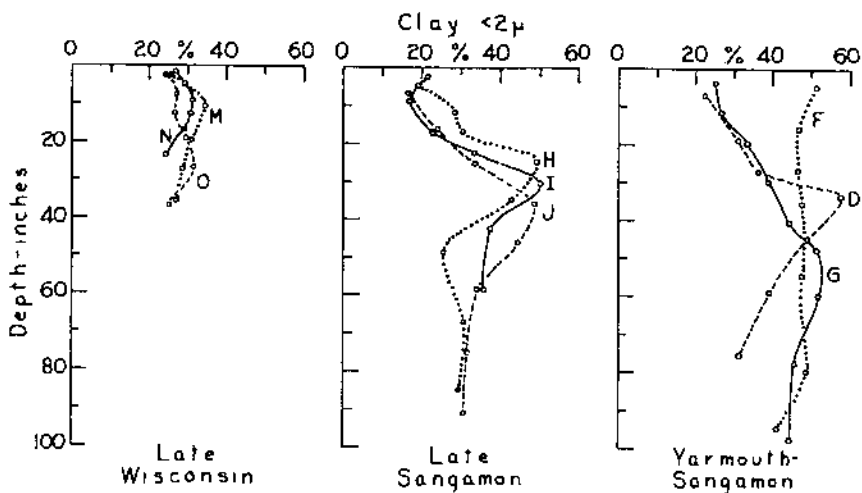

FIGURE 57.—Clay content of soils of Late Wisconsin-Recent age or Early Wisconsin pediment in comparison to paleosols of Late Sangamon and Yarmouth-Sangamon surfaces.

The weathering ratios of the Late Wisconsin-Recent soils indicate that they have not been subjected to intensive weathering (fig. 58, table 26). Soil development has not resulted in destruction of weatherable minerals with the resultant orderly arrangement of weathering ratios, as in the Late Sangamon and Yarmouth-Sangamon paleosols.

In the coarser sand fractions (2-0.5 m.m.) of the soil on the Early Wisconsin pediment, weatherable mineral matter, such as granite, diorite, and basalt, is abundant in all horizons of the sola. Resistant mineral matter occurs also.

There are distinct contrasts of characteristics between the Late Wisconsin-Recent soils on the Early Wisconsin pediment, the Late Sangamon paleosols, and the Yarmouth-Sangamon paleosols (fig. 57). All these soils are developed wholly or in part in Kansan till, but they occur on geomorphic surfaces of different ages. Thicknesses of sola increase from profiles on the youngest surface to those on the oldest (table 27). The thicknesses and clay content of the B horizons also increase from soils on the youngest surface to soils on the oldest.

Curves of the average weathering ratios of soils of the geomorphic surfaces (fig. 59) are displaced toward the right from soils of the youngest surface to those of the oldest in both the heavy- and light-mineral fractions. Intensity of mineral weathering increases to the right, that is, greater ratios indicate greater amounts of resistant minerals relative to weatherable minerals.

In the Late Wisconsin-Recent soils very little mineral destruction has occurred in weathering and, as a result, an orderly ar-

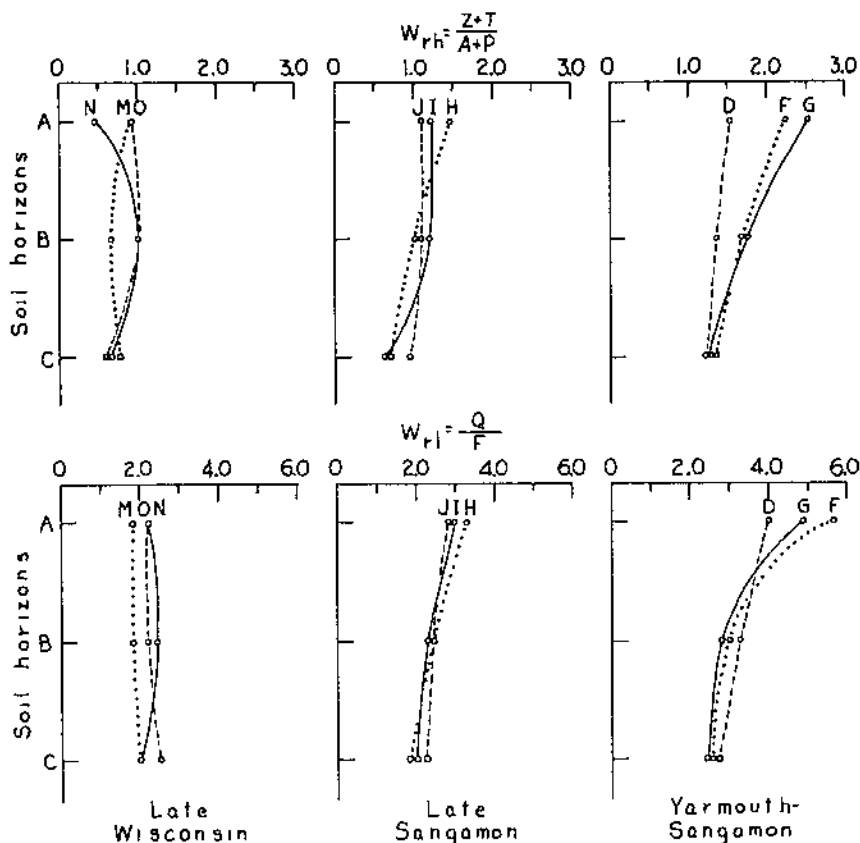

FIGURE 58.—Weathering ratios of heavy mineral fractions (W_{rh}) and light mineral fractions (W_{rl}) of soils of Late Wisconsin-Recent age on Early Wisconsin pediment in comparison to paleosols of Late Sangamon and Yarmouth-Sangamon surfaces.

rangement has not been established among the weathering ratios of the horizons of the soil profiles. In both light and heavy minerals, values of the A horizons lie to the left of values of the B horizons. In the Late Sangamon paleosols, mineral weathering has progressed to the point that an orderly arrangement of values has been established among the values of the profile horizons. There is a relatively greater displacement of values to the right in the A_2 horizon in contrast to the less weathered B horizons. The values of the C horizons of the Late Sangamon paleosols group closely with those of the relatively unweathered Late Wisconsin-Recent soils.

In the most intensively weathered Yarmouth-Sangamon paleosols (fig. 59) there is greater displacement of values to the right. Values of the ratios of the A_2 and A_3 horizons are displaced far-

TABLE 26.—Abundance of major resistant and weatherable minerals in very fine sand fractions of soils on Early Wisconsin pediment

Soil	Heavy minerals			Light minerals		
	Re-sistant ¹	Weather-able ²	Wrh ³	Re-sistant ⁴	Weather-able ⁵	Wrl ⁶
Soil M	<i>Percent</i>	<i>Percent</i>		<i>Percent</i>	<i>Percent</i>	<i>Percent</i>
A ₁ -----	⁷ 47	49	0.95	66	34	1.94
B ₂ -----	40	59	.67	66	34	1.94
C-----	43	54	.78	67	33	2.03
Soil N						
A ₁ -----	32	66	.48	68	32	2.12
B ₂ -----	50	48	1.04	69	31	2.22
C-----	38	59	.64	67	33	2.03
Soil O						
A ₁ -----	48	51	.95	69	31	2.22
B ₂ -----	50	47	1.96	69	31	2.22
C-----	37	61	.61	72	28	2.57

¹ Zircon and tourmaline.² Amphiboles and pyroxenes: hornblende, hypersthene, augite, enstatite.³ $Wrh = \frac{\text{zircon} + \text{tourmaline}}{\text{amphiboles} + \text{pyroxenes}}$; ratios to base 1.⁴ Quartz.⁵ Feldspars (orthoclase, microcline, plagioclase).⁶ $Wrl = \frac{\text{quartz}}{\text{feldspar}}$; ratios to base 1.⁷ Percentages by count.

TABLE 27.—Comparison of some characteristics of soils of geomorphic surfaces

Soil ¹	Thickness of solum	Thickness of B horizon	Clay content of B horizon
Late Wisconsin-Recent soil on Early Wisconsin pediment	<i>Inches</i>	<i>Inches</i>	<i>Percent</i>
M-----	29	22	34.6
N-----	15	11	31.2
O-----	32	23	32.2
Average-----	25	19	32.3
Late Sangamon			
H-----	39	29	49.5
I-----	46	32	50.7
J-----	70	56	49.1
Average-----	52	39	49.7
Yarmouth-Sangamon			
D-----	68	44	57.7
F-----	85	62	50.7
G-----	87	70	51.4
Average-----	80	59	53.2

¹ Letters refer to profiles designated in text.

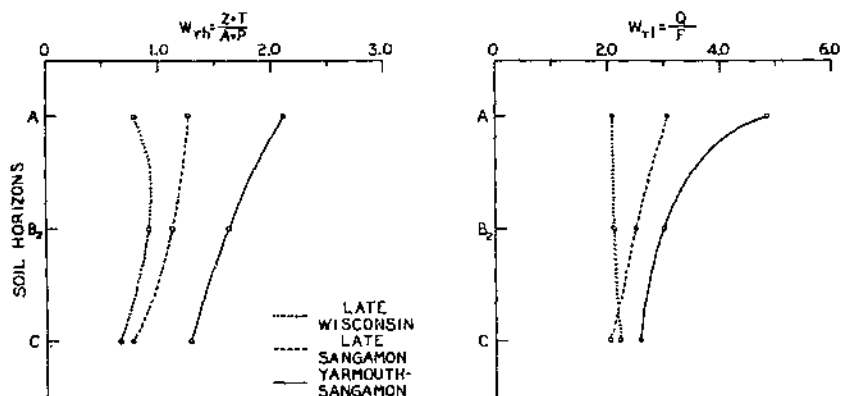

FIGURE 59.—Averages of weathering ratios of heavy-mineral fractions (W_{rh}) and light-mineral fractions (W_{rl}) of soils of geomorphic surfaces.

ther to the right than the lesser but still intensely weathered B horizons.

Undoubtedly the major cause of the differences in intensity of development and weathering in the three groups of soils is age.

VALLEY SLOPES AND SIDE-VALLEY WATERWAYS

Valley slopes. Late Wisconsin-Recent slopes bevel the succession of Pleistocene deposits and the sequence of geomorphic surfaces. The slopes truncate the Tazewell loess with its regional weathering zonation of Late Wisconsin age, the Farmdale loess, and the underlying Kansan till. They also bevel the Yarmouth-Sangamon paleosolic surface, the Late Sangamon paleosolic surface, and the Early Wisconsin pediment. Thus, they must be younger than the youngest deposit and youngest geomorphic surface that they bevel. The youngest deposit is Tazewell loess and the youngest geomorphic surface is the weathering zonation in the loess of Late Wisconsin age. The slopes therefore cannot be older than Late Wisconsin and probably are Recent in age.

Correspondingly, the weathering zones of Tazewell loess, the various paleosolic surfaces, and Kansan till crop out on the Late Wisconsin-Recent slopes (pl. III).

In the South Turkey Creek area the valley slopes range from 6 to 15 percent. The slopes are correlative with the Late Wisconsin-Recent dissection cycle identified along the regional traverse from Bentley to Adair.

Sharpsburg soils developed in the Tazewell loess on the slopes of Late Wisconsin-Recent age. Shelby, Steinauer, and Shelby-Steinauer intergrade soils developed in Kansan till on slopes of Late Wisconsin-Recent age.

Side-valley waterways. On the Late Wisconsin-Recent slopes are concave, spoon-shaped waterways that contain ill-defined channels in their bottoms. In the South Turkey Creek area the side-valley waterways (fig. 60) are on slopes of 15 percent and in adjacent areas on slopes of 20 percent.



FIGURE 60.—Side-valley waterway on Late Wisconsin-Recent slope in Kansan till, South Turkey Creek area.

The waterways slope downward to main, tributary, and side streams (pl. III) and occupy almost 50 percent of the total area of Late Wisconsin-Recent slopes. In many places (pl. III: E.8, 3.8, E.8, 3.9) the waterways head at the level of Late Sangamon paleosolic surface, at the level of the Yarmouth-Sangamon surface (D.2, 1.7), or at the level of the Early Wisconsin pediment (F.8, 2.9).

On some interfluves many side-valley waterways are on valley slopes above the bounding streams. One interfluve (pl. III: C.90, 4.75-E.0, 5.1) is bounded on the east by South Turkey Creek and on the north and south by tributaries of South Turkey Creek. Numerous side-valley waterways occur on the north, east, and south valley slopes of the interfluves. The waterways, in general, are alined almost at right angles to their controlling streams regardless of the slope aspect. Here, in this geographic-distribution pattern of side-valley waterways, is the evidence of interfluve reduction by running water. Erosion progresses at the heads and at the lateral peripheral margins of the waterways and tends to reduce the interfluve upland. This is the pedimentation process.

The side-valley waterways have variable thicknesses of alluvial fills. The alluvium generally is thickest at the mouth of and along the axis of the waterway and thins out toward the head and peripheral margins of the waterway. Generally, at the base of the alluvium regardless of position within the waterway, a stone line marks the contact with the underlying till.

For example, a series of borings in the side-valley waterway located the erosion surface at the base of the alluvial fill. The mouth of the old waterway is 80 feet below its head (fig. 61, A). The waterway axis is 30 and 45 feet below the adjacent south and north bounding interfluve ridges, respectively (B-B'). Along the axis the old erosion surface has a slope of 9 percent.

Filling of this waterway by alluvium resulted in a spoon-shaped, or cirque-like depression on the valley slope (fig. 61, B). Local

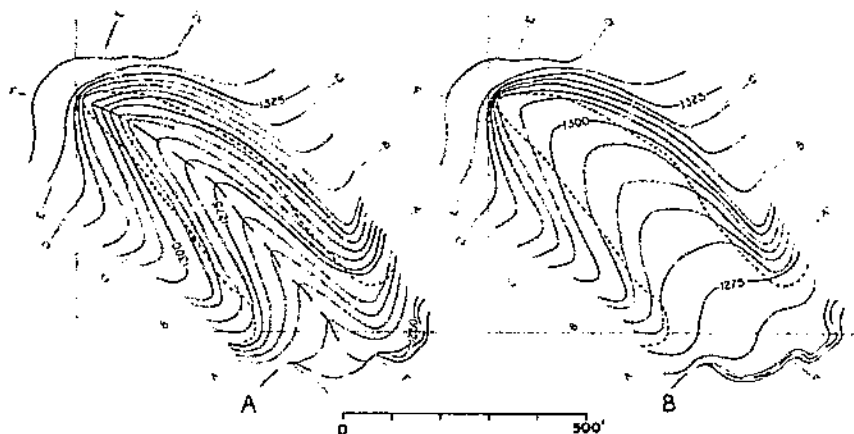

FIGURE 61.—Surface configuration of side-valley waterway after dissection (A) and after fill (B).

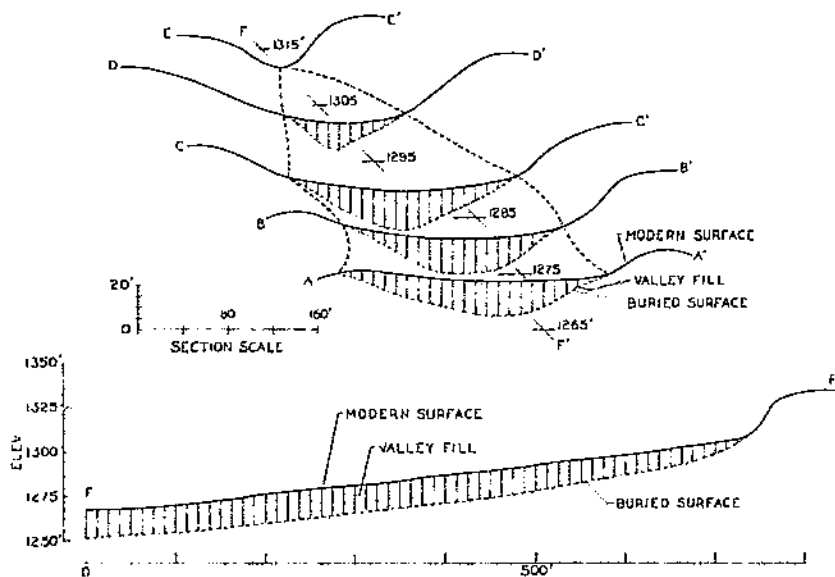

FIGURE 62.—Alluvial fill in side-valley waterway. (See fig. 61).

relief decreased. The mouth of the waterway is now only 65 feet below the head. The alluvial surface at its lowest point now lies only 15 and 30 feet below the adjacent north and south bounding interfluvial ridges, respectively (B-B'). Along the axis of the waterway the alluvial surface has a slope of 5.5 percent.

The alluvial fill along the axis of the waterway is uniformly thick, 15 to 16 feet, from the mouth to near the head (fig. 62, F'-F), where it then thins out rapidly to the head of the waterway.

Across the waterway it is thickest along the axis and thins rapidly toward the peripheral margins (fig. 32, A-A' . . . D-D'). A section in the alluvium near the axis of the waterway at an elevation of 1,275 feet (61, B) is:

Section P:

IC	Dark grayish brown (10YR 4/2) gritty light silty clay loam; thin laminae of sand; leached raw modern alluvium.
0-22 inches	
IIA ₁₆	Black (10YR 2/1) heavy silty clay loam; strong medium granular; firm; leached; upper horizon or recently buried Humic Gley soil.
22-36 inches	
IIA ₂₀	Very dark gray (10YR 3/1) heavy silty clay loam; mottled with dark brown (10YR 4/3); weak fine subangular blocky; firm; leached.
36-48 inches	
IIB	Dark gray (10YR 4/1) heavy silty clay loam; mottled with yellowish brown (10YR 5/4); weak fine subangular blocky; sparse thin clay skins on aggregate faces; firm; leached; lower horizon of recently buried Humic Gley soil.
48-72 inches	
IIC	Gray (10YR 5/1) silty clay loam; mottled with dark brown (10YR 4/3) and light gray (10YR 7/1); massive; firm; leached.
72-112 inches	
112-136 inches	Light gray (10YR 6/1) light silty clay loam; mottled with yellowish brown (10YR 5/4); massive; firm; leached; sparse small pebbles.
136-178 inches	Olive (5Y 5/3) light silty clay loam; mottled with dark gray (5Y 4/1); massive; firm; leached; sparse small pebbles; grit increases progressively in lower 18 inches.
178-185 inches	Olive (5Y 5/3) gravelly silt loam; mottled with olive-brown (2.5Y 4/4); massive; firm; leached; stone line at base of side-valley waterway alluvium.
185+ inches	Olive (5Y 5/3) loam; coarse angular blocky; firm; leached Kansan till.

In the section (fig. 63) a textural discontinuity occurs at a depth of 22 inches, which is the contact of postcultural sediment overlying the old alluvial fill (fig. 64). The total sand content decreases abruptly at this contact from 14 percent to less than 2 percent. Organic-matter content increases abruptly 60 percent at the contact.

The total sand content in the alluvium below the contact ranges from less than 1 percent to not more than a few percent to a depth of 150 inches. Throughout this zone the particle-size distribution of the sediment (fig. 63) does not differ greatly from that of loess. The nature of the sediment suggests that this portion of the fill was derived mainly by the stripping of Tazewell loess from the slopes adjacent to the waterway.

The sand content below 150 inches progressively increases to 178 inches where the stone line occurs at the base of the alluvium. The stone line rests, in turn, on leached Kansan till at a depth of 185 inches.

In the solum of the Humic Gley, 22 to 72 inches, the clay content is practically uniform, 38 percent in the A₁ horizon and 37 percent in the B₁ horizon. Below the solum the clay content gradually decreases with depth. In the solum the organic matter decreases from a maximum of 8 percent in the upper part of the A₁ horizon to 4.5 percent in the lower part of the B₁ horizon, and then progressively decreases with depth.

The occurrence of a buried soil in the alluvium beneath the postcultural sediment suggests that the landscape must have been stable around the waterway before man cropped the slopes. The

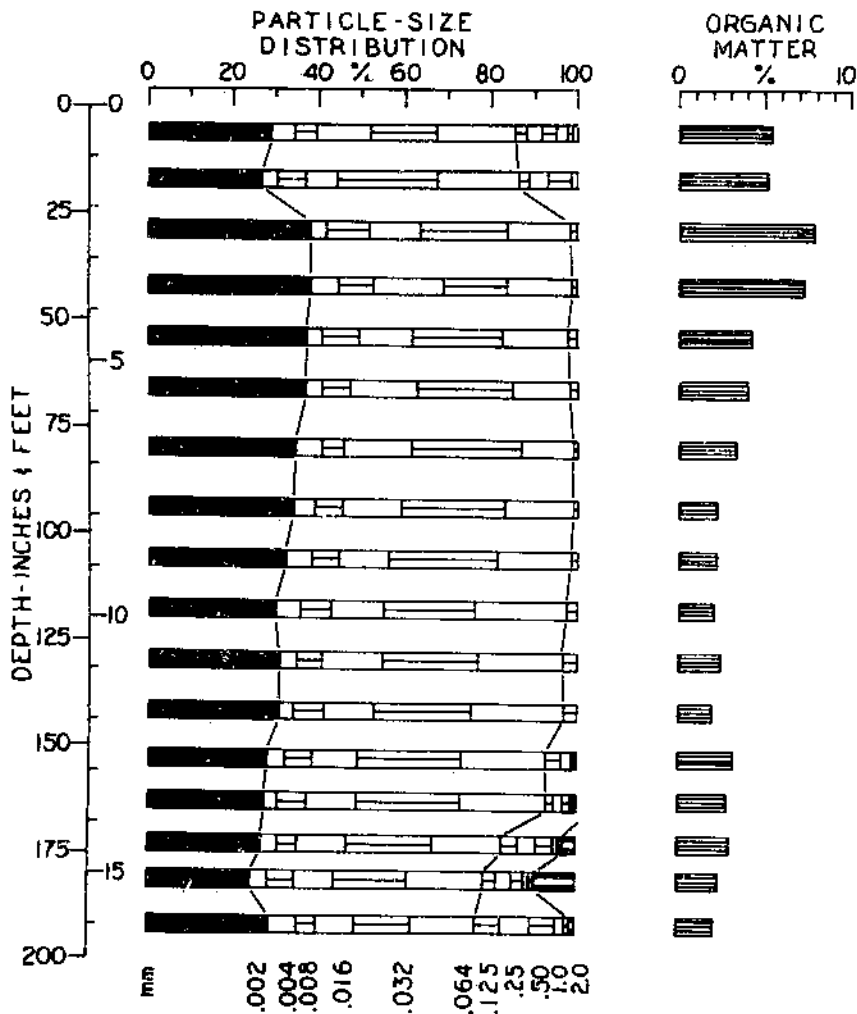

FIGURE 63.—Characteristics of the alluvium in a side-valley waterway.

loessial nature of the fill to a depth of 150 inches indicates that the main source of the alluvial sediment was the loess on the slopes adjacent to the waterway. The small amount of sand and gravel in this part of the fill indicates that the till, on which the waterway is emplaced, was not a major source of sediment. Thus, the nature of the fill suggests that after loess was stripped from the till, the greater resistivity to erosion of the till may have been a factor in stabilizing the slopes above the waterway.

The slopes around the waterway pass downward and under the alluvial fill (fig. 61). This relationship is similar to the gully fill in cut 39 along the regional traverse. The alluvial fills in the side-valley waterways in the South Turkey Creek area are believed to

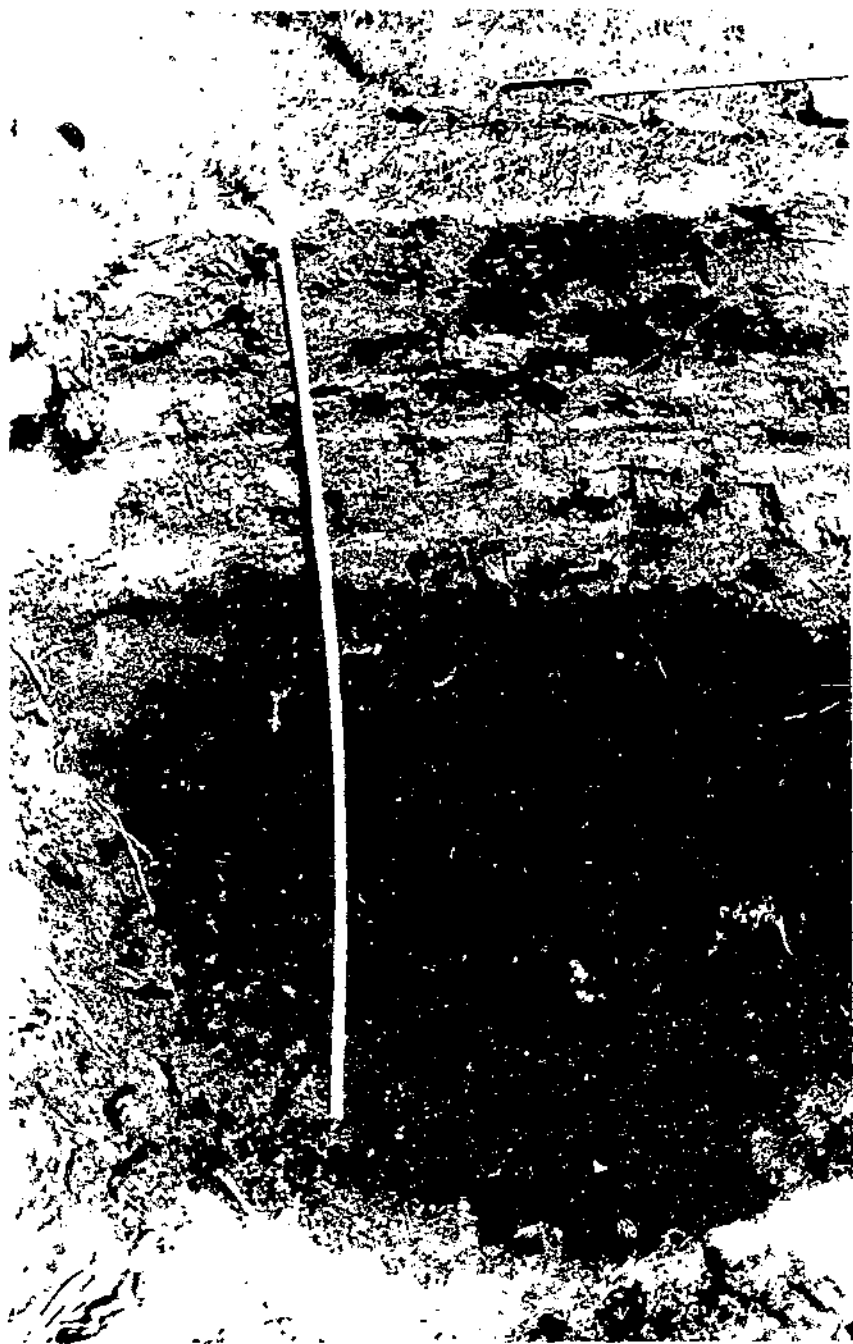

FIGURE 64.—Postcultural, bedded sediment overlying Humic Gley soil in alluvial fill in a side-valley waterway.

be correlative with the gully cycle of the regional traverse. The gully cycle was dated at $6,800 \pm 300$ years (44, p. 446). Thus, the side-valley alluvial fills probably are of Recent age. Correspondingly, the slopes above that pass downward beneath the alluvial fills must be less than 6,800 years old, and also must be of Recent age.

The probable radiocarbon age of the alluvial fills also leads to a strong inference in regard to possible cause of stabilization of the landscape. Lane (31, p. 167) on the basis of pollen analysis of a peat bed in north-central Iowa showed a sequence of changes from the base upward: (1) spruce forest, (2) mixed fir, birch, and spruce, (3) birch with fir and oak, (4) oak with birch and grasses, and (5) grassland vegetation with two intercalated strong semi-arid element indicated by major proportions of amaranths.

Radiocarbon samples were collected from Lane's spruce zone, coniferous-deciduous forest transition zone, and the zone indicating the beginning of grass dominance. The basal spruce zone is dated at $11,660 \pm 250$ years (54, p. 686-687), the coniferous-deciduous forest transition at $8,170 \pm 200$ years, and the beginning of dominance of grass at $6,570 \pm 200$ years.

Lane (31, p. 169) concluded from the pollen sequence that the climate changed from cool, moist conditions of the coniferous period (11,660 years) to a warm, moist environment that accompanied the change from coniferous to deciduous forms (8,170 years). A gradual drying of the climate ended just before grass dominance (6,570 years), and the grassland environment has been continuous since that time.

Lane's "culmination of climatic desiccation just prior to grass dominance" is close to the age of the basal gully fill in southwestern Iowa, dated at 6,800 years, that probably is correlative with the side-valley waterway fills. Such climatic change may have prepared the landscape for gullying and side-valley waterway cutting. The grassland environment that followed the change may have been responsible for stabilization of the gullies, waterways, and adjacent slopes.

Soils developed in the sediments of the side-valley waterways are classified as the Arbor series.

VALLEY FILLS

The main, tributary, and side-stream valleys of the South and North Turkey Creek areas have thick alluvial fills. The bases of alluvial fills of the side-valley waterways can be traced in deep borings to the lateral-marginal bases of the valley fills. Thus, the fills are all parts of the same Recent alluviation cycle.

In most places the alluvial fills of the valleys are so thick that they cannot be penetrated completely by manual boring. The thickness of the alluvial fill in the valley of North Turkey Creek (fig. 47) was determined by an earth-resistivity method.³⁵ The

³⁵ H. R. Dixon, then geologist, Iowa Highway Commission, conducted the resistivity survey.

determinations of alluvium thicknesses were checked at three places along the traverse by manual borings.

The maximum thickness of Recent alluvium in the valley of North Turkey Creek is 26 feet.

Many of the alluvial fills of the side-valley waterways debouche, in the form of alluvial fans, onto the flood plain alluvium of the valley below.

Relation of Pleistocene Deposits, Geomorphic Surfaces, and Soils

An integrated part of the geomorphic study in the Greenfield quadrangle was the study of the soils reported in detail in the next chapter. The relationships of soils and geomorphology along an interfluvium in the South Turkey Creek areas are shown in figure 65.

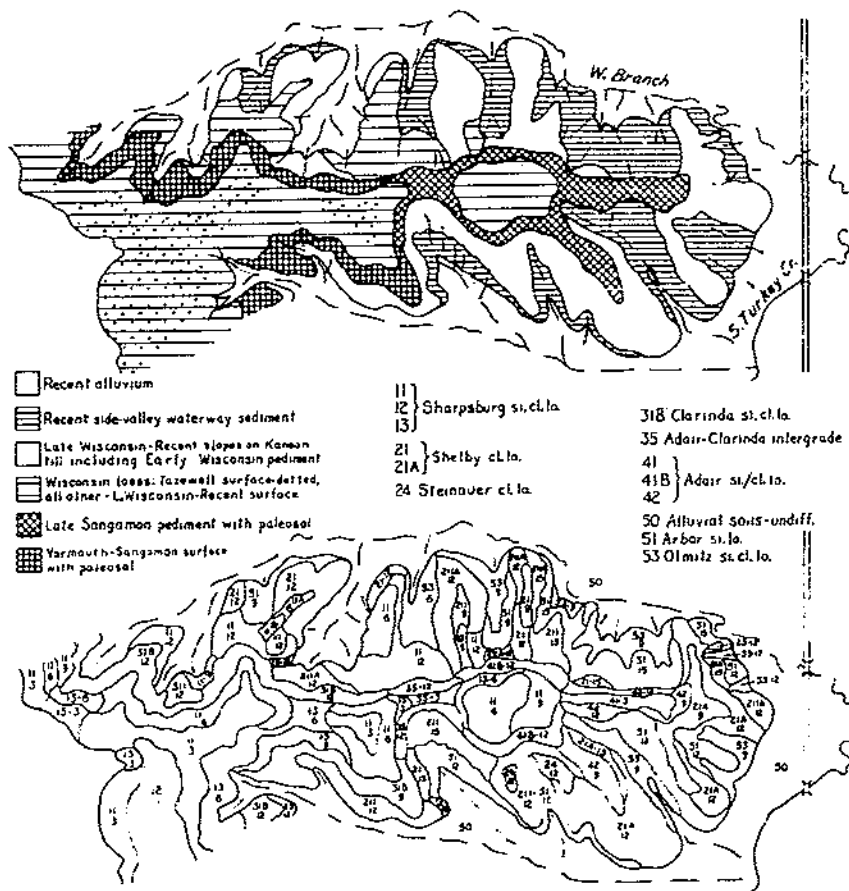

FIGURE 65.—Relationship of Pleistocene deposits, geomorphic surfaces, and soils along an interfluvium in South Turkey Creek area (pl. III: B.80, 4.00-F.60, 3.85).

Resurrection of Paleosolic Surfaces

YARMOUTH-SANGAMON SURFACE AND SOILS

Late Wisconsin-Recent slopes have encroached on the upland divides and interfluves so that the Yarmouth-Sangamon paleosols outcrop within the continuum of soils on the modern surface (fig. 39). Where the paleosols outcrop, they are considered in the scheme of classification of soils as the Clarinda silty clay loam (fig. 65).

The Clarinda soils are associated with the highest level of the landscape and as a band on the slopes around the heads of drainage ways (fig. 65). They may be identified by their gray colors, heavy textured B horizons (clay or heavy silty clay), strong subangular blocky structure in the B horizons, and the absence of weatherable mineral material in the coarser particle-size fractions.

The Yarmouth-Sangamon paleosols have varying morphologies, and are paleo-Planosols, paleo-Humic Gleys, paleo-Gray Brown Podzolic soils, and paleo-intergrades. All of these have been included within the Clarinda series. On the Late Wisconsin-Recent slopes the paleosols crop out in various stages of truncation. Parts of the paleo-sola may be eroded. These soils also are grouped within the Clarinda series.

LATE SANGAMON SURFACE AND SOILS

Late Wisconsin-Recent slopes have encroached on the interfluvial summits so that the Late Sangamon-pediment paleosols crop out within the continuum of soils on the modern surface (fig. 65). Where the interfluvial summits have been narrowed considerably, the Tazewell loess has been stripped from the summits so that the paleosols may be exhumed in toto. However, in most places the Late Sangamon paleosols occur on the modern surface in various stages of truncation. Generally the B horizons occur at the modern surface. In this case the soil is classified as Adair clay loam.

Where the complete paleosol has been exposed the soil is Adair silt loam.

The Adair soils are associated with the intermediate level of the landscape and may be either a band around the shoulders of an interfluvial or may occupy the entire summit (fig. 65). Where a truncated paleosol occurs on the modern surface, the soil may be recognized by its strong brown or reddish-brown color, heavy textured B horizon (clay or heavy silty clay), a strong subangular blocky structure, and the presence of weatherable mineral material in the coarser particle-size fractions.

Where the entire paleosol occurs on the modern surface, the soil may be recognized by its light colored, light textured A₂ horizon overlying a stone line and by its strong brown or reddish-brown B horizon.

The Late Sangamon-pediment paleosols have uniformly similar morphologies, and are paleo-Gray Brown Podzolic soils. Only the pediment paleosols are included within or as a variant of the Adair series. The Late Sangamon valley-slope fan and flood plain

paleosols (sections K, L) differ morphologically from the pediment paleosols. The fan and flood plain paleosols have not been placed within the scheme of classification of soils but probably should be considered as variants of the Adair series.

Tazewell Upland and Soils

STABILITY OF LOESS-UPLAND SURFACE

Several lines of evidence have been detailed to demonstrate the stability of the loess surface on the upland divides. Briefly (1) the complete weathering zonation underlies the surface; (2) the upland surface is parallel to the weathering zones in the loess. The surface must have been in place while the zones formed. The superposed soil also must have been being formed at the same time as the zonation; (3) the upland surface is parallel to the Pleistocene deposits and the geomorphic surfaces and soil formation must have begun after loess deposition ceased; (4) the upland slopes are of such slight declivity that significant erosion is precluded; (5) radiocarbon dating of the surface shows that loess deposition ceased about 14,000 years ago. Side slopes pass downward under side-valley alluvium whose base is 6,800 years old. The upland should be 7,000 to 8,000 years older than the side slopes.

SOILS OF LOESS-UPLAND SURFACE

Sharpsburg silty clay loam is on the loess-upland surface.

Hutton (21, 22) concluded that in the "chrono-litho-sequence" of soils of Monona-Marshall-Sharpsburg-Gundy-Seymour the increased intensity of development, in the order named, was caused by "effective time of soil formation" (22, p. 322). "Effective time" was defined as the summation of the weathering that occurred during loess deposition and the weathering since the cessation of loess deposition. The Sharpsburg was considered near the median of the time sequence, and the Marshall somewhat younger.

In tracing the loess, in which the Marshall and Sharpsburg soils developed, under the Cary till of the Des Moines lobe (fig. 53) it was found that the buried soil in the uppermost part of the buried loess is a Regosol. The Regosol was dated at $13,910 \pm 400$ years.³⁶ It seems apparent that at that time both the Marshall and the Sharpsburg soils were no more than Regosols, that were developing under coniferous forest.³⁷ If these soils were alike at the time the northern soils were buried, the differences between the southern soils on the exposed landscape must have developed since Cary time. Actual time has been the same in both Marshall and Sharpsburg areas.

³⁶ A projection of the boundary between the Marshall and Sharpsburg association areas needs be extended only 12 miles beneath the Cary till to the localities of the buried Regosols (fig. 53, H, I).

³⁷ At sections H and I (fig. 53) spruce trees were found rooted in place in the buried Regosols (54, p. 680-685). No mention is made in the previous studies on loess-derived soils of a possible different vegetative environment.

Because weathering since cessation of loess deposition cannot account for the differences in the Marshall and Sharpsburg soils, that part of the "effective time" factor, weathering concurrent with loess deposition, must be responsible for such soil differences. However, the gastropod fauna described in the Greenfield quadrangle (table 21) was collected from basal calcareous Wisconsin loess below the Sharpsburg soil. Similarly the gastropod faunas described along the regional traverse (table 12) were collected from basal calcareous Wisconsin loess below the Marshall soils. Calcareous loess at about the same depth beneath both the Marshall and the Sharpsburg appears to preclude any difference in "effective time" of weathering during loess deposition. Effective time of weathering, then, cannot explain the differences between the Marshall and Sharpsburg soils. Nor can it explain differences between the Monona and Marshall soils along the regional traverse where similar stratigraphic and composition relationships hold true. Thus, along Hutton's loess-derived soil traverse, from Monona to Marshall to Sharpsburg to Grundy and to Seymour, effective time of weathering is subject to question as an explanation of the differences between Monona, Marshall, and Sharpsburg.

Other field evidence shows that the morphological development of the Sharpsburg silty clay loam took place largely after deposition ceased. The heavy textured, plastic Yarmouth-Sangamon paleosols have been deformed subsequent to mantling by Tazewell loess (fig. 66). Protuberances of the clayey paleosol extend 2 to

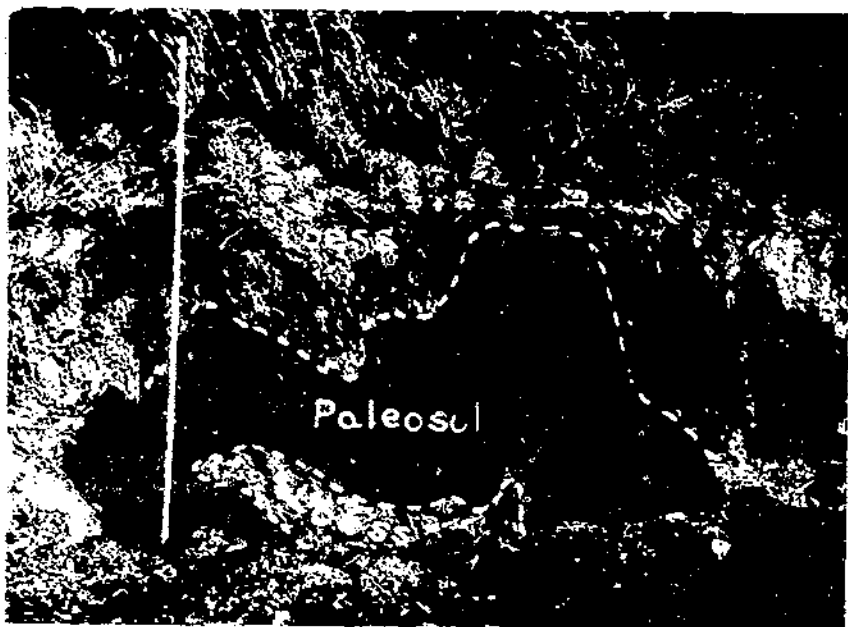

FIGURE 66.—Involutions of Yarmouth-Sangamon paleosol incorporating deoxidized and leached Tazewell loess.

2½ feet above the main mass of the paleosolic surface into the overlying Tazewell loess. Masses of the basal deoxidized and leached loess are incorporated in the deformed paleosol. Protuberances such as these are involutions generally attributed to freezing and thawing in a periglacial regime.

Because the involutions incorporate Tazewell loess, they must be Cary age. The Greenfield quadrangle is only 10 miles from the margin of the Cary drift lobe (fig. 53).

In many places the solum of the Sharpsburg soil crosses above an involution, and even though the involution extends upward to the base of the solum, the horizons of the soil are not deformed. The soil must have formed after the involutions. Thus, the horizonation of the Sharpsburg must be younger than the Cary periglacial activity.

Late Wisconsin-Recent Complex and Soils

INTERFLUVE SUMMITS AND SOILS

Late Wisconsin-Recent stripping of Tazewell loess from interfluvial summits not only exposed the Yarmouth-Sangamon and Late Sangamon paleosols but the Early Wisconsin pediment as well. Because the pediment was cut in Kansan till, stripping of the surficial loess has exposed the till to pedogenic processes in Late Wisconsin-Recent time. Brunizems have developed in the till, and these soils are the Shelby loam.

Where the loess has not been stripped completely from the interfluvial summits, the modern Brunizem, Sharpsburg silty clay loam, developed in the loess.

VALLEY SLOPES AND SOILS

The Late Wisconsin-Recent valley slopes truncate not only the older paleosolic surfaces but also the Tazewell loess and Kansan till.

Evidence demonstrates the younger age of the valley slopes relative to the stable upland surface of Tazewell age. (1) They angularly bevel the sequence of geomorphic surfaces. Because the youngest geomorphic surface is the Early Wisconsin pediment, they must be younger than Early Wisconsin. (2) They angularly truncate the sequence of Pleistocene deposits. Because the youngest deposit is Tazewell loess, they must be younger than Tazewell. (3) They angularly bevel the regional weathering zonation in Tazewell loess. Because the weathering zonation is Late Wisconsin, they must be younger than Late Wisconsin. (4) They pass downward under alluvial fills whose basal layer is probably 6,800 years old. Therefore they cannot be older and are probably younger; they must be of Recent age. (5) They have gradients of 6 to 15 percent, on which erosion is to be expected.

The Sharpsburg silty clay loam occurs on the Recent valley slopes in Tazewell loess (fig. 65). This kind of Sharpsburg soil differs morphologically and in profile properties from the Sharpsburg soil that occurs on the stable Tazewell upland. In no sense

can the sloping Sharpsburg and the level Sharpsburg be considered members of a toposequence.³⁸ The two kinds of Sharpsburg soils occur on two geomorphic surfaces of different ages. Five lines of evidence each separate one geomorphic surface from the other. The sloping Sharpsburg occurs in the beveled oxidized and leached zone of the Tazewell loess.

Recent valley slopes also bevel the intensely mottled lower zone of the oxidized and leached Tazewell loess as well as the basal deoxidized and leached loess. The Sharpsburg silty clay loam also was formed in these kinds of parent material.

The Kansan till is truncated by the Recent valley slopes (fig. 65). Brunizems, classified as the Shelby clay loam, and the Regosol, Steinauer clay loam, was formed in the till.

SIDE-VALLEY WATERWAY ALLUVIUM AND SOILS

Soils classified as the Arbor silt loam (fig. 65) was formed in the side-valley waterway alluvium. Poetsch³⁹ considers these soils to be both Brunizems and Wiesenbodens (Humic Gleys).

The foregoing information is necessary for understanding the genetic, geographic, and classification characteristics of the soils of the Greenfield quadrangle. The soils are described and discussed in detail in the succeeding chapter of this report.

³⁸ A toposequence is a sequence of soils whose properties are functionally related to topography as a soil formation factor (1, p. 440).

³⁹ Poetsch, Ernst. 1956. Soil profile variation in alluvium: Unpublished M.S. Thesis, Iowa State College.

Chapter 3

Soils of the South Turkey Creek Area, Greenfield Quadrangle, Adair County, Iowa

by Raymond B. Daniels and John G. Cady, soil scientists, Soil Conservation Service

Introduction

The Greenfield quadrangle is in Adair County, Iowa, and takes in the area of T. 75 N. to T. 77 N. and R. 30 W., and the eastern part of R. 32 W. Within this quadrangle is the South Turkey Creek study area. It consists of all or parts of sections 12 and 13, T. 76 N., R. 32 W., and sections 7, 17 and 18, T. 76 N., R. 31 W.

Here was carried out the detailed study of the influence of landscape evolution on soil genesis and the relationship between geomorphic surfaces and soil geography. Fundamental information obtained should provide basic data for soil classification and possible prediction of future erosion and weathering.

Soils

The study area is in the Shelby-Sharpsburg-Winterest soil association area (fig. 67). Most of the soils investigated are Brunizems formed in Tazewell loess, Kansan till, or valley-side alluvium (table 28). Paleosols and Regosols were described and mapped and a large area of undifferentiated soils in recent alluvium was mapped but not studied (table 28). Several variants or subdivisions of soil series were found that have not been reported in recent soil surveys of nearby counties (57). The Shelby series was separated into units 21 and 21A by different depths to carbonate and unit 22, a sandy subsoil variant. A Shelby-Steinauer intergrade, unit 23, was mapped. Three units (11, 12, and 13) within the Sharpsburg series could be separated. Unit 12 is apparently similar to the 0- to 2-percent slope phase of the Sharpsburg as mapped in Taylor County (57, pp. 45-46).

Two new soil series were established during this investigation. The Adair series consists of soils of the uncovered late Sangamon surface. These soils formerly were included with both the Lagonda and Shelby series. Soils like the Arbor series in valley-side alluvium were included with the Shelby series.

Laboratory Procedures

The laboratory analyses were completed in the Mandan, N. Dak., and Beltsville, Md., soil survey laboratories.

TABLE 28.—Soils (series) recognized in the South Turkey Creek area

Series	Phase	Parent material	Geomorphic surface	Greenfield quadrangle unit No.
Sharpsburg		Tazewell loess	Tazewell	11
Sharpsburg	0-1 percent	Tazewell loess	Tazewell	12
Sharpsburg		Tazewell loess	Late Wisconsin-Recent	11
Sharpsburg	Deoxidized substratum	Tazewell loess	Late Wisconsin-Recent	13
Shelby	Moderately shallow to carbonate.	Kansan till	Late Wisconsin-Recent	21
Shelby	Deep to carbonate	Kansan till	Late Wisconsin-Recent	21A
Shelby, sandy subsoil variant		Kansan till	Late Wisconsin-Recent	22
Shelby-Steinauer intergrade		Kansan till	Late Wisconsin-Recent	23
Steinauer		Kansan till	Late Wisconsin-Recent	24
Clarinda		Kansan till	Yarmouth-Sangamon	31B
Adair, variant A		Pedisediment and Kansan till	Late Sangamon	41
Adair		Pedisediment and Kansan till	Late Sangamon	41B
Adair		Kansan till	Late Sangamon	42
Adair-Clarinda intergrade		Pedisediment and Kansan till	Late Sangamon	35
		Alluvium	Redent	50
Arbor		Side-valley waterway alluvium.	Late Wisconsin-Recent	51
Olmitz		Side-valley waterway alluvium.	Late Wisconsin-Recent	53

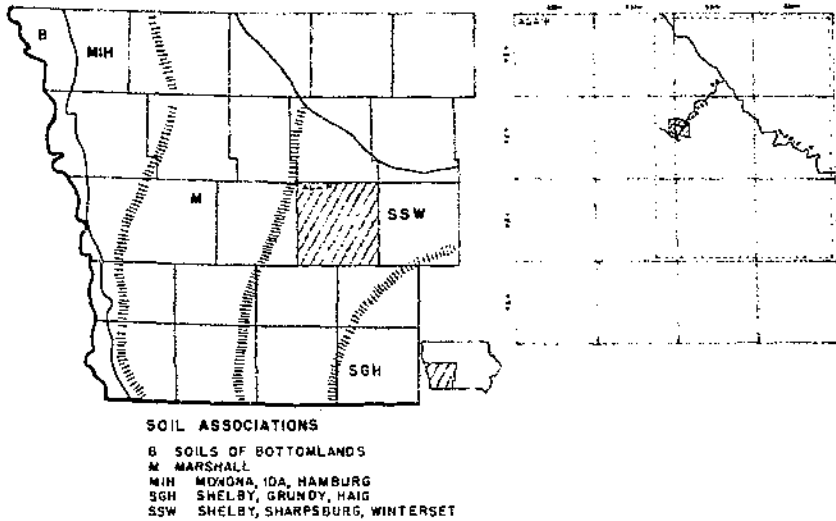

FIGURE 67.—Location of area studied with reference to soil association areas of southwestern Iowa.

METHODS

Particle-size distribution analyses were made by the method described by Kilmer and Alexander (27) and Kilmer and Mullins (28).

The pH was determined by a Beckman pH meter using a glass electrode; soil-water ratio was 1-1.

Organic carbon and extractable cations were determined by methods described by Peech et al. (41). A 77-percent recovery factor was used for calculation of organic-carbon percentages. The macro method was used for determination of exchangeable cations. The following changes were made in the extractable cation procedures: (1) A 25-gram soil sample was leached with 250 ml. of ammonium acetate. (2) A cerate titration for calcium was used instead of the permanganate method. (3) Sodium and potassium were determined by flame spectrophotometry.

Total nitrogen was determined by a modified A.O.A.C. Kjeldahl method using boric acid for collection of the distillate.

Calcium carbonate equivalents were determined by acid neutralization method.

All data are reported on an oven-dry basis.

Exposed Paleosols

Late Wisconsin-Recent erosion in the Greenfield quadrangle removed the loess mantle from valley slopes and intermediate level ridges and uncovered the Yarmouth-Sangamon and late Sangamon paleosols. These paleosols now occur on the modern surface as narrow bands below the high divides (48, p. 443).

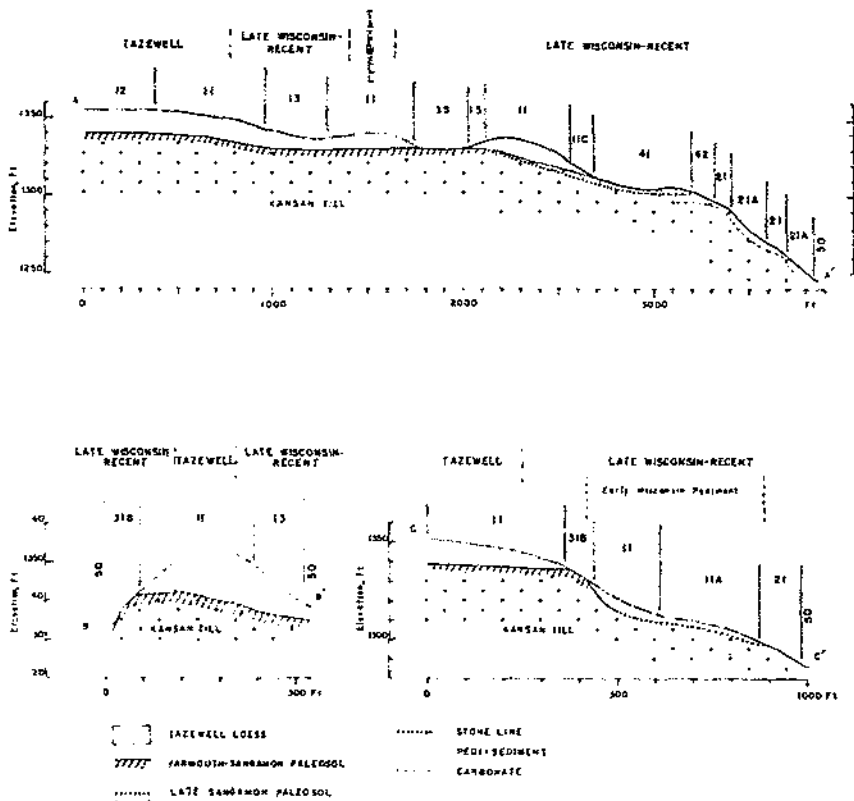

FIGURE 68.—Relation of soils to geomorphic surfaces: A-A (pl. V; C.23, 4.44—F. 53, 4.0)³⁰; B-B' (pl. V; C.33, 3.65 — C.53, 4.16); C-C' (pl. V; C.71, 3194 — D.26, 311). The numbers key with unit numbers in the last column of table 28. The broken lines between Tazewell and late Wisconsin-Recent show the approximate boundaries between these geomorphic surfaces.

Paleosols of the Yarmouth-Sangamon surface in Kansan till are on a swell and swale surface with a local relief of 5 to 10 feet (fig. 68; 48, p. 445). The topography caused drainage differences and soils comparable to modern Planosols, Humic Gley, and Gray-Brown Podzolic soils formed (48, p. 449). The different great soil groups were put in the Clarinda series (pl. V; 31B) because the area covered by each group is too small to separate at normal map scale.

As shown in Chapter 2, the intermediate topographic level in the South Turkey Creek area is controlled by the late Sangamon surface. This erosion surface was cut into Kansan till below the level of the Yarmouth-Sangamon surface and is marked by a stone

³⁰ Grid coordinates on plate V are designated in the following manner: Pl. V; C.23, 4.44: C.23 is located 23/100 of the distance between grid lines C and D. 4.44 is located 44/100 of the distance between grid lines 4 and 5.

line on Kansan till. The stone line is overlain by finer textured, transported sediment derived from the till. The late Sangamon surface is mantled by Wisconsin loess in most places, but late Wisconsin-Recent erosion has removed part of the loess and exposed the paleosols (fig. 46: 41, 42). These paleosols are classified as the Adair series. The paleosols are truncated by late Wisconsin-Recent erosion. In areas the complete solum is present but in other places only the B horizon is left. Three mapping units, one a complex, cover this range of conditions (pl. V).

Three paleosols are described here—a buried Yarmouth-Sangamon paleosol on the crest of a swell; a late Sangamon paleosol exposed intact, Adair silt loam, which has an A, B, and C horizon sequence; and a truncated soil, Adair clay loam, that has B₂ and B₃ horizons exposed at the surface.

Yarmouth-Sangamon paleosol (pl. V: H.58, 4.00)

A _{7b} 0-10 inches	Grayish brown (10YR 5/2) ⁴⁰ light ⁴¹ silty clay loam; weak fine platy structure; friable; leached Kansan till; gradual boundary.
B _{1b} 10-15 inches	Grayish brown (10YR 5/2) medium silty clay loam; weak fine sub-angular blocky structure; friable; gradual to clear boundary.
B _{2b} 15-34 inches	Gray to dark gray (10YR 5/1 to 4/1) clay; moderate fine subangular blocky structure; thick continuous clay skins ⁴² ; firm; gradual boundary.
B _{3b} 34-46 inches	Grayish brown (2.5Y 5/2) clay; weak medium subangular blocky structure; thin continuous clay skins; firm; gradual boundary.
C _{1b} 46+ inches	Olive gray (5Y 5/2) medium clay loam; massive; leached Kansan till.

Adair silt loam (pl. V: E.O, 2.33)

AP 0-6 inches	Very dark grayish brown (10YR 3/2) silt loam; weak fine granular structure; friable; leached late Sangamon pedis sediment; clear boundary.
PA ₂ ⁴⁴ 6-10 inches	Dark brown (10YR 4/3) silt loam; weak fine and medium subangular blocky structure; peds tend to be arranged in a very weak squamose fashion; friable; clear boundary.
PB ₁ 10-17 inches	Dark brown (7.5YR 4/3) light silty clay loam; moderate subangular structure; discontinuous white silt coats on the surfaces of the peds; firm; stone line at base of horizon; clear boundary.
HPB ₂ ⁴³ 17-37 inches	Dark grayish brown (10YR 4/2) clay; weak subangular blocky structure; thick continuous clay skins; interiors of peds grayish brown and yellowish red (2.5Y 5/2 and 5YR 4/8); slickensides common; firm; leached Kansan till; gradual boundary.

⁴⁰ Munsell colors of moist soil unless otherwise stated.

⁴¹ Heavy loams and silt loams and light, medium, and heavy clay loams are used throughout the profile descriptions. This is done to show the estimated differences in texture because many of the horizons within a profile are within one textural class. Estimated range of clay content for each subdivision of a textural class is as follows: Heavy loam and silt loam, 20-27 percent; clay loam and silty clay loam; light, 28-32; medium 32-36; heavy, 36-40 percent.

⁴² Clay skins are described as thin, medium, or thick. Thin clay skins form a definite gelatinous coating on the peds but are not easily visible in cross section with a hand lens. Medium clay skins are easily visible in cross section with a hand lens, thick clay skins without a hand lens. Thin coatings are not visible in cross section; they may be pressure faces since the ped surface is smoother than the interior and the surface is not waxy.

⁴³ Roman numerals preceding A, B, or C indicate differences in parent material (??).

⁴⁴ The uppercase letter P designates a paleosolic or relict horizon (55).

IIPB₁ 37-44 inches Dark grayish brown (10YR 4/2) clay to heavy clay loam; abundant fine and medium grayish brown and dark reddish gray (2.5Y 5/2 and 5YR 4/2) mottles; weak medium blocky structure; thin continuous clay skins; firm; gradual boundary.

IIPC₁ 44+ inches Variegated dark yellowish brown and yellowish red (10YR 4/4 and 5YR 4/8) medium clay loam; massive.

Adair clay loam (pl. V: F.06, 3.83)

A₁ 0-8 inches Very dark brown (10YR 2/2) light clay loam; weak fine granular structure; firm; leached Kansan till; gradual boundary.

PB₂ 8-22 inches Dark grayish brown (10YR 4/2) light clay; moderate fine subangular blocky structure; thin continuous clay skins; firm; gradual boundary.

PB₃ 22-40 inches Dark grayish brown (10YR 4/2) heavy clay loam; weak medium blocky structure; continuous thin clay skins in vertical channels in the lower part of the horizon; firm; gradual boundary.

PC₁ 40+ inches Dark brown (10YR 4/3) medium clay loam; common grayish brown (2.5Y 5/2) streaks and strong brown mottles; massive; firm; leached Kansan till.

The Yarmouth-Sangamon paleosols are highly weathered, as shown by the absence of megascopic weatherable minerals, the high clay content of the B horizon, and very thick sola (48, p. 450). The late Sangamon paleosols are less weathered and have megascopic weatherable minerals in the B horizons.

Late Sangamon paleosols are similar to Gray-Brown Podzolic soils but many of them have stronger chroma and redder hues than the modern Gray-Brown Podzolic soils in Iowa (48, p. 451). The B horizons of the paleosols have a reddish cast in road cuts. On detailed examination the exterior color of the pedis is grayish brown (2.5Y 5/2) due to clay skins, and the interior colors are yellowish red (5YR 4/8) to dark grayish brown (10YR 4/2).

The Adair-Clarinda intergrade soils occur in the transitional zone between the Yarmouth-Sangamon and the late Sangamon geomorphic surfaces and have characteristics of paleosols on both surfaces. The B horizon ranges from the intense gray of the Clarinda series to the dark brown and dark grayish brown of the Adair series. The Adair-Clarinda intergrade soils contain megascopic weatherable minerals throughout the profile. These soils do not have a stone line. Pedis sediment, if present, cannot be differentiated from the underlying Kansan till.

The paleosols have developed black to very dark brown (10YR 2/1 to 2/2) A horizons 4 to 12 inches thick since exposure on the modern surface. The white silt coatings on the ped surfaces in the B₁ horizon of the late Sangamon paleosols, and in some places in the upper part of the B₂ horizon, are absent where the paleosol is buried. These silt coatings probably indicate the start of destruction of the B₁ horizon by the downward extension of the A₂ horizon.

Paleo-Geomorphic Surfaces and Soil Geography

Several factors make mapping paleosols of the Yarmouth-Sangamon and late Sangamon surfaces a problem. The area occupied by one type of paleosols is not large. Paleosols are exposed in narrow bands on the valley slopes; only on the intermediate-level ridgetops are there large areas (pl. V). These soils are

truncated and the characteristics of each site depend upon the horizon sequence exposed (fig. 68: 31B, 41, 42) as in the distinction between the Adair silt loam and Adair clay loam.

On parts of the landscape where the Yarmouth-Sangamon and late Sangamon surfaces join, the paleosol pattern is complex (pl. V: 1.0, 5.5). But separation of the paleosols is relatively easy once the relation between the old geomorphic surfaces and the modern landscape are understood. In the South Turkey Creek area, the Clarinda series occurs only on the high level divide positions and the Adair series on the intermediate level. The series have distinctive morphological characteristics, and the different topographic levels are easily seen in the field. But there are exceptions. An Aftonian gumbotil that would be included in the Clarinda series is described in Chapter 2. Thus, if Nebraskan as well as Kansan till is exposed on the valley slopes, modern Clarinda soils may occur above and below the late Sangamon paleosols.

Soils of the Tazewell Uplands

The Tazewell surface is a narrow strip on divides in the South Turkey Creek area. Across divides its slopes are less than 1 percent and down divides less than 3 percent (pl. V).

There are distinct weathering zones in the Tazewell loess that influence modern soils. This zonation in the center of the divides is:

Oxidized and
leached zone
(surficial soil).
Mottled

Dark grayish brown (10YR 4/2) light silty clay loam; many grayish brown (2.5Y 5/2) and few strong brown (7.5YR 5/6) mottles; massive; this subzone grades downward to the underlying grayish brown zone.

Grayish brown

Grayish brown (2.5Y 5/2) light silty clay loam; common fine and medium strong brown and yellowish brown mottles; massive; boundary usually a strong brown (7.5YR 5/6) soft iron band 1 to 2 inches thick.

Deoxidized and
leached zone.

Gleyed

Grayish brown (2.5Y 5/2) matrix; segregation of iron oxides into yellowish red and dark reddish brown (5YR 4/6 and 3/4); pipestems and mottles; abrupt boundary.

In areas under the gently convex divides and the sloping ridgetops (fig. 69, A-A', pl. V: C.19, 4.53-D.06, 4.85) the mottled and grayish brown zone in some places is a brown zone. Across the convex and level divides the lower gleyed zone may thicken in the direction that the Yarmouth-Sangamon surface slopes (fig. 69).

The mottled and grayish brown zones probably are old features of a postdepositional wet period. The lower deoxidized and leached zone is known to perch water after the spring thaw and rains. The areas where this zone crops out on the valley slopes (fig. 69, B-B', D-D') often are saturated after periods of high rainfall. This condition may have been the cause of the lower deoxidized and leached zone. In places modern slopes cut across

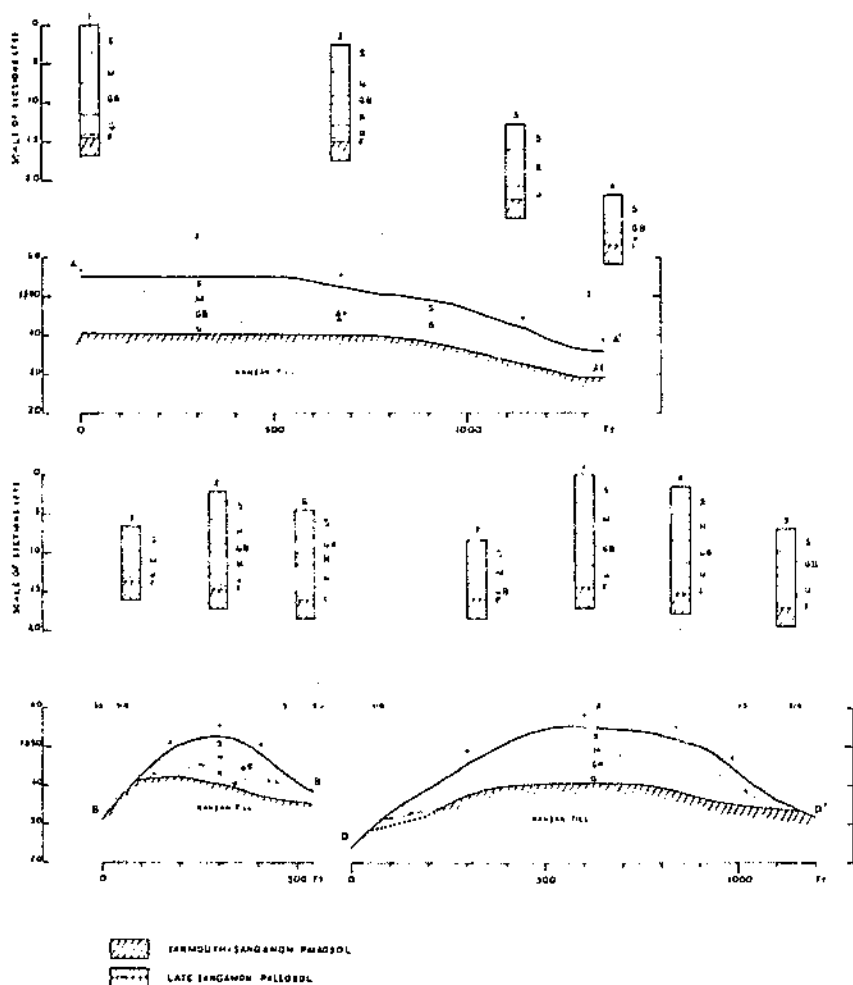

FIGURE 69.—Distribution of weathering zones in the Tazewell loess: Oxidized and leached zone: S, surficial soil; M, mottled; GB, grayish brown; B, brown. Deoxidized and leach zone: G, gleyed; F, Farmdale. Unit 11 soil D was sampled at section 2; unit 11 soil C at section 5; and unit 13 soil F at section 9.

the weathering zonation in the loess (fig. 69, B-B', D-D') and exposure of the various zones is a factor in determining the color in soils on the modern slopes.

Two members of the Sharpsburg series occupy the Tazewell surface (table 28; pl. V): unit 12 on the level divides only and unit 11 on the gently convex divides and ridgetops.

A unit 12 Sharpsburg silty clay loam on a level divide (fig. 70; pl. V: C.23, 4.44) has the following morphology:

Profile A, unit 12, Sharpsburg silty clay loam (fig. 70; pl. V: C.23, 4.44): Slope 0 percent; cultivated field.

- A_{1P} 0-6 inches Black (10YR 2/1) light silty clay loam; massive; friable; leached Tazewell loess; abrupt boundary.
- A₁₂ 6-15 inches Black (10YR 2/1) which crushes to very dark gray (10YR 3/1); light silty clay loam; weak to moderate granular; friable; gradual boundary.
- AB 15-18 inches Mixed very dark grayish brown (10YR 3/2) and black (10YR 2/1); medium silty clay loam; weak to moderate subangular blocky structure; friable; gradual boundary.
- B₂₁ 18-21 inches Dark grayish brown (10YR 4/2) with some mixing of very dark gray (10YR 3/1) medium to heavy silty clay loam; moderate fine subangular blocky structure; thin continuous clay skins; friable; gradual boundary.
- B₂₂ 21-28 inches Dark grayish brown (10YR 4/2) heavy silty clay loam; weak medium subangular blocky; thin to medium continuous clay skins; friable; gradual boundary.
- B₃ 28-43 inches Dark grayish brown (10YR 4/2) medium silty clay loam; few fine distinct grayish brown (2.5Y 5/2) mottles; weak medium blocky structure; pedis are arranged in weak to moderate, medium to coarse prisms; prisms are covered with a thin coat of dark grayish brown (2.5Y 4/2) silt grains; thin discontinuous clay skins are visible between the silt coat; friable; gradual boundary.
- C 43-72 inches Dark grayish brown (10YR 4/2) light silty clay loam; common distinct yellowish brown to strong brown and grayish brown (2.5Y 5/2) mottles; moderate coarse prismatic structure; thin discontinuous dark grayish brown (10YR 4/2) clay skins on vertical prism faces; friable.

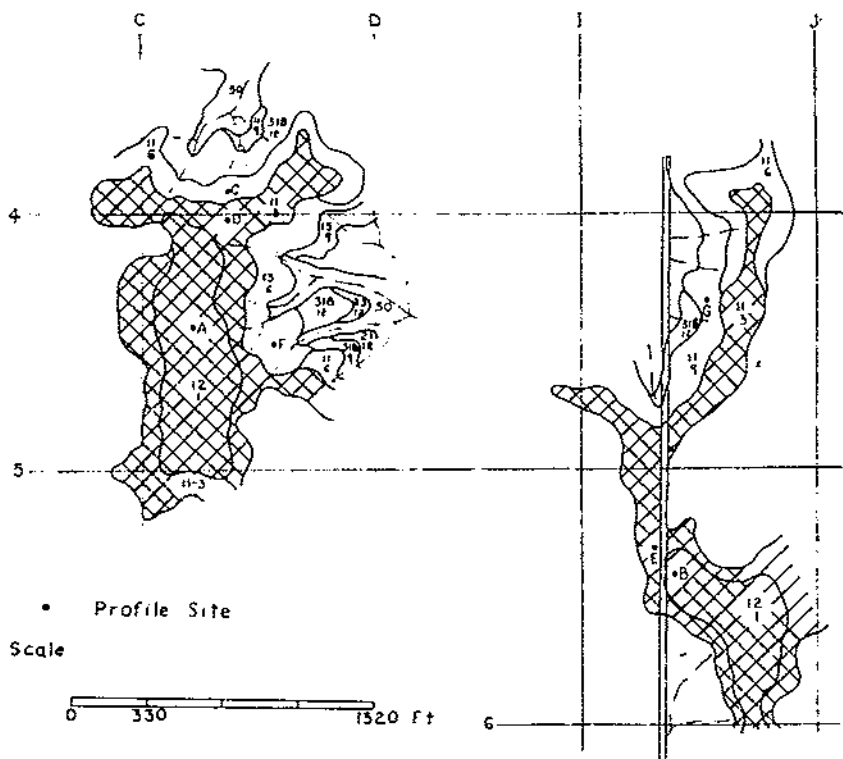

FIGURE 70.—Location of soils sampled in Tazewell loess. The hatched area is uneroded and stable. The rest was eroded in late Wisconsin or Recent time.

This soil is different from most other Brunizems because it has a black A_1 horizon. But the colors of the B horizon and the gradual boundaries between master horizons are typical for Brunizems (65, p. 159).

In unit 12 profiles, B horizons have 6 percent more clay than A horizons and 7 to 8 percent more clay than C horizons (fig. 71). Clay illuviation is indicated by the thin to medium clay skins in B horizons. The horizon of maximum clay in both soils is 24 inches below the surface and has about 38 percent clay (table 29). (The description of profile B is in the appendix.) The high base saturation and pH in the surface of profile B may be due to calcareous dust from a gravel road or to agricultural limestone.

The morphology of Sharpsburg soils on the gently convex ridge-tops of the Tazewell surface is different from that of soils on the level divides. This is shown by the following description (Unit 11) a Sharpsburg silty clay loam (fig. 70 d; pl. V: C.37, 4.03).

Profile D, unit 11, Sharpsburg silty clay loam (fig. 70; pl. V: C.37, 4.03): Slope 2 percent, slightly convex; cultivated field.

A_{1P} 0-6 inches Very dark brown (10YR 2/2) light to medium silty clay loam; cloddy; friable; leached Tazewell loess; abrupt boundary.

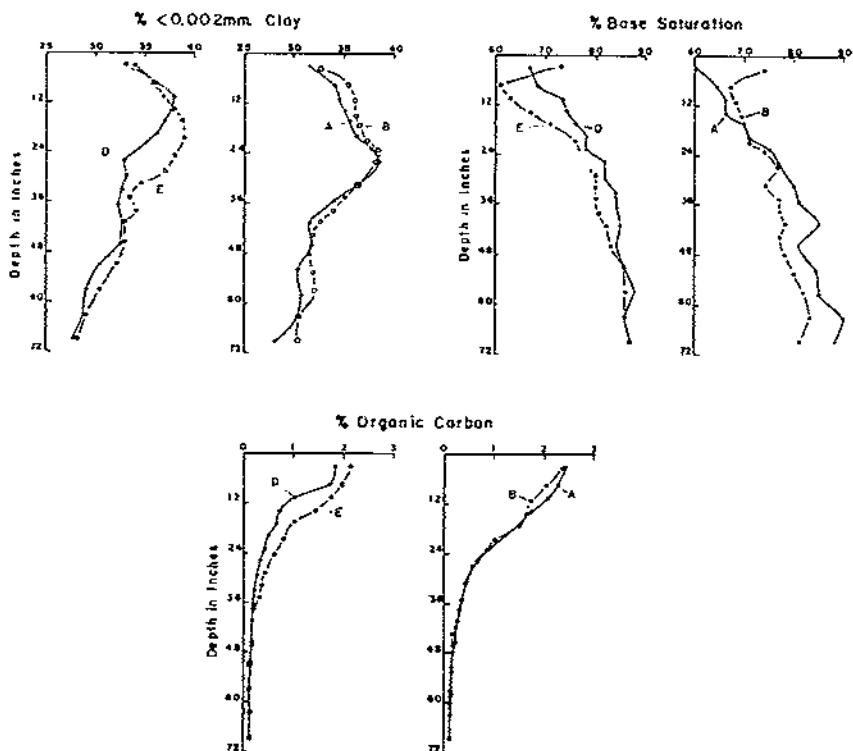

FIGURE 71.—Distribution with depth of clay, percent base saturation, and organic carbon of soils on the Tazewell surface. A and B, unit 12 profiles; D and E, unit 11 profiles.

TABLE 29.—Analysis of Sharpsburg silty clay loam, unit 12
PROFILE A, CULTIVATED (PL. V: C.23, 4.44)

Depth (In- ches)	Horizon	Size class and particle diameter									pH	Or- ganic car- bon	Ni- tro- gen	C/N	CaCO ₃ equiv- alent	Cation- ex- change capac- ity (sum)	Extractable cations					De- gree of base saturation
		Very coarse sand (2-1 mm)	Coarse sand (1- 0.5 mm)	Medi- um sand (0.5- .25 mm)	Fine sand (0.25 -0.10 mm)	Very fine sand (0.10- .05 mm)	Silt (0.05- .002 mm)	Clay (<0.002 mm)	0.2- .02 mm	0.02- .002 mm							Ca	Mg	H	Na	K	
		Percent	Percent	Percent	Percent	Percent	Percent	Percent	Percent	Percent							meq/ 100g	meq/ 100g	meq/ 100g	meq/ 100g	meq/ 100g	
0-6	A _{1P}	0.1	0.4	0.4	0.4	0.9	66.1	31.5	34.1	33.3	5.4	2.40	11.9	27.8	12.9	3.1	11.0	0.1	0.8	60		
6-9	A ₁₂	.3	.3	.4	.4	.9	63.9	34.1	31.8	33.2	5.5	2.29	11.8	29.9	14.0	4.4	10.7	.1	.7	64		
9-12	A ₁₂	.1	.3	.3	.4	1.0	63.3	34.6	32.0	31.9	5.7	2.07	11.8	30.1	13.5	5.7	10.2	.1	.6	66		
12-15	A ₁₂	.1	.3	.3	.4	.9	63.0	35.0	31.5	32.6	5.7	1.72	156	29.2	13.4	5.1	9.8	.2	.7	66		
15-18	A ₃ B ₁	.2	.3	.3	.3	.9	62.6	35.4	31.1	32.6	5.7	1.52	138	31.9	16.0	5.8	9.3	.1	.7	70		
18-21	B ₂₁	.1	.3	.3	.3	1.1	61.8	36.2	31.1	32.0	5.8	1.21	112	29.9	14.0	6.6	8.5	.2	.7	71		
21-24	B ₂₂	.1	.3	.3	.3	1.2	60.5	37.6	30.0	31.8	5.6	.90	86	31.2	15.4	7.4	7.5	.2	.7	75		
24-28	B ₂₇	—	.1	.1	.1	1.3	60.5	37.8	30.1	31.8	5.6	.67	68	31.5	16.2	7.3	7.1	.2	.7	77		
28-33	B ₃	—	.2	.2	.3	1.4	61.7	36.2	31.6	31.7	5.7	.46	48	32.7	17.1	8.3	6.4	.2	.7	80		
33-38	B ₃	—	.1	.1	.1	1.5	64.1	33.8	32.5	33.3	5.7	—	—	31.3	16.2	8.3	—	.2	.7	81		
38-43	B ₃	—	.1	.2	.3	1.4	66.6	31.4	35.6	32.6	5.9	—	—	28.5	15.5	7.8	—	.3	.7	85		
43-49	C ₁	—	.1	.2	.4	1.5	60.0	31.8	34.5	33.2	6.1	—	—	29.2	13.7	7.9	—	.3	.7	81		
49-55	C ₁	—	.1	.1	.4	2.0	67.2	30.3	37.7	31.7	6.3	—	—	28.6	15.5	7.8	—	.3	.7	84		
55-61	C ₁	—	.1	.1	.4	1.9	66.6	30.9	38.1	30.7	6.5	—	—	28.1	15.2	7.8	—	.3	.7	85		
61-66	C ₁	—	.1	.1	.5	1.4	67.4	30.4	34.4	34.7	6.6	—	—	27.1	15.3	8.2	—	.3	.7	90		
66-72	C ₁	—	.1	.2	.3	1.7	69.5	28.2	38.0	33.4	6.7	—	—	26.0	14.6	7.5	—	.3	.7	88		

PROFILE B, CULTIVATED (PL. V: I.41, 5.41)

0-7	A _{1P}	0.2	0.4	0.3	0.4	0.9	65.2	34.3	32.0	6.4	2.35	195	12.0	28.7	17.2	3.4	7.4	—	0.7	74
7-10	A ₁₂	—	.2	.2	.4	1.2	62.5	35.5	32.7	31.2	5.6	2.04	172	28.9	14.0	4.7	9.5	—	.7	67
10-13	A ₁₂	.1	.3	.2	.4	1.0	61.9	36.1	30.7	32.4	5.6	1.72	151	28.0	13.3	5.0	9.0	—	.7	68
13-16	A ₁₂	.3	.4	.2	.4	.7	62.1	36.0	30.8	32.3	5.6	1.65	148	27.0	13.2	5.4	8.7	—	.6	69
16-19	A ₃	.1	.4	.2	.4	.9	61.7	36.3	31.0	31.8	5.3	1.51	132	29.5	13.6	6.6	8.5	.1	.6	71
19-22	B ₂₁	.1	.2	.2	.3	1.0	61.1	37.2	29.9	32.2	5.5	1.03	95	29.3	14.0	7.1	7.5	.1	.7	74
22-25	B ₂₁	—	.1	.2	.3	1.0	60.1	38.3	29.3	32.0	5.6	.84	78	30.8	14.9	8.0	8.4	.1	.7	77
25-29	B ₂₂	—	.1	.1	.2	1.1	60.6	37.8	30.6	31.3	5.6	.60	60	32.7	15.2	8.3	8.2	.1	.7	74
29-33	B ₃	—	—	.1	.1	.9	62.5	36.3	30.1	33.4	5.8	.43	48	29.7	15.4	4.4	6.1	.1	.6	77
33-36	B ₃	—	—	—	.1	1.3	63.6	35.0	33.9	31.1	5.5	—	—	26.9	15.4	4.6	6.1	.2	.6	77
36-39	B ₃	—	.1	—	.3	1.0	64.6	33.9	34.6	31.2	5.8	—	—	27.3	15.2	5.4	5.9	.2	.6	78
39-42	B ₃	—	.1	.2	.4	1.2	65.5	32.6	34.1	32.8	6.0	—	—	25.7	14.9	4.2	5.0	.2	.6	77
42-46	B ₃	—	.1	.1	.4	1.1	66.5	31.8	34.0	33.9	6.0	—	—	25.4	15.0	4.0	5.0	.3	.6	78
46-50	C ₁	—	—	.3	.3	1.0	67.1	31.5	34.1	34.2	6.1	—	—	25.6	15.1	4.5	5.1	.3	.6	80
50-54	C ₁	—	.1	.1	.3	1.5	66.0	32.0	35.0	32.7	6.2	—	—	25.2	15.3	4.3	4.6	.3	.7	82
54-60	C ₁	—	.1	.2	.4	1.1	66.1	32.1	34.3	33.1	6.2	—	—	25.4	15.8	4.3	4.4	.3	.6	83
60-66	C ₁	—	.1	.2	.4	1.0	67.8	30.5	36.8	32.2	6.4	—	—	24.8	15.3	4.3	4.3	.3	.6	83
66-72	C ₁	—	.1	.2	.5	1.2	67.4	30.6	35.4	33.5	6.3	—	—	24.8	15.0	4.4	4.6	.2	.6	81

AB 6-9 inches	Very dark brown (10YR 2/2) medium silty clay loam with some mixing with dark brown (10YR 3/3); weak fine and very fine subangular blocky structure; friable; clear boundary.
B ₂₁ 9-18 inches	Dark brown (10YR 3/3) medium to heavy silty clay loam with mixing of very dark grayish brown (10YR 3/2) in upper 4 inches; weak to moderate fine to very fine subangular blocky structure; thin discontinuous clay skins; friable; gradual boundary.
B ₂₂ 18-25 inches	Dark grayish brown (10YR 4/2) medium silty clay loam; few fine faint strong brown mottles; weak to moderate fine subangular blocky structure; thin continuous clay skins; moderately friable; gradual boundary.
B ₃₁ 25-35 inches	Dark grayish brown (10YR 4/2) light to medium silty clay loam; common fine faint grayish brown (2.5Y 5/2) and few fine distinct strong brown and yellowish brown mottles; moderate medium blocky structure; peds are arranged in weak medium prisms; moderately friable; gradual boundary.
B ₃₂ 35-43 inches	Variegated dark grayish brown and grayish brown (10YR 4/2 and 2.5Y 5/2) light to medium silty clay loam; common fine distinct strong brown mottles and few fine distinct dark oxides; weak medium coarse blocky structure arranged in weak medium prisms; friable; gradual boundary.
C ₁ 43-72 inches	Variegated grayish brown and dark brown (2.5Y 5/2 and 7.5Y 4/4) light silty clay loam to heavy silt loam with few fine distinct dark oxides; massive; friable

Unit 11 profile E is closer to the level divides than profile D and in many of its properties intergrades toward unit 12 (fig. 71). This is shown by the deeper clay maximum in profile E than in unit 11 profile D (table 30). The organic carbon content and its decrease with depth and the base saturation of profile E also is more like unit 12 soils than unit 11 profile D.

The Sharpsburg soil studied by Hutton (21, pp. 426-427) is morphologically similar to these unit 11 profiles but the horizon of maximum clay was at 34 to 37 inches and had 34.2 percent clay.

Soils of the Late Wisconsin-Recent Complex

The complex cut-and-fill late Wisconsin-Recent geomorphic surface now occupies the largest part of the landscape in the South Turkey Creek area (pl. III). During the formation of this surface the loess and till were eroded and the Yarmouth-Sangamon and late Sangamon paleosols exposed. Areas in and around the valley-side waterways were filled with alluvium.

Soils of the late Wisconsin-Recent surface are members of the Sharpsburg, Shelby, Arbor, and Olmitz series. Sharpsburg soils have formed in loess, Shelby in till, and the Arbor and Olmitz in valley-side alluvium.

Units 11 and 13 of this geomorphic surface are in loess, have different morphologies, and occupy different parts of the landscape. Unit 11 soils are on the low summits and convex valley slopes and their morphology is similar to unit 11 soils of the Tazewell surface. These soils are above exposed Yarmouth-Sangamon and late Sangamon paleosols but similar soils also are on early Wisconsin pediments and valley slopes below the paleosols. The slopes of unit 11 soils are 6 to 12 percent. The unit 13 soils are on concave slopes at or near heads of drainageways and on convex slopes in topographic saddles and between closely spaced drainageways.

TABLE 30.—Analysis of Sharpsburg silty clay loam (unit 11)
PROFILE D. CULTIVATED (PL. V: C.37. 4.03)

Depth (inches)	Horizon	Size class and particle diameter									pH	Organic carbon	Nitrogen	C/N	CaCO ₃ equivalent	Cation-exchange capacity (sum)	Extractable cations					Degree of base saturation
		Very coarse sand (2-1 mm)	Coarse sand (0.5-1 mm)	Medium sand (0.5-1 mm)	Fine sand (0.25-10 mm)	Very fine sand (0.10-.05 mm)	Silt (0.05-.002 mm)	Clay (<0.002 mm)	0.2-0.2 mm	0.02-.002 mm							Ca	Mg	R	Na	K	
		Percent	Percent	Percent	Percent	Percent	Percent	Percent	Percent	Percent	Percent	Percent	Percent	Percent	meq/100g	meq/100g	meq/100g	meq/100g	meq/100g	meq/100g	Percent	
0-6	A ₁ P	0.1	0.2	0.2	0.4	1.3	63.0	34.8	33.1	31.4	5.7	1.82	.163	11.2	29.5	13.0	6.0	9.8	0.3	0.5	67	
6-9	A ₁ B ₁	—	.2	.2	.4	1.2	61.8	36.2	31.2	32.0	5.7	1.75	.151	11.6	30.0	13.1	6.7	9.5	0.3	0.5	68	
9-12	B ₁	—	.1	.1	.2	1.3	60.3	38.0	30.2	31.5	5.8	1.04	.95	10.9	31.5	14.3	8.0	8.5	0.3	0.5	73	
12-15	B ₁	—	.2	.1	.2	1.4	60.2	37.9	30.5	31.2	5.8	.82	.78	10.5	32.1	14.7	8.1	8.5	0.3	0.5	74	
15-18	B ₁	—	.2	.1	.3	1.6	60.7	37.1	31.7	30.8	5.9	.65	.65	10.0	30.9	14.4	8.2	7.5	0.3	0.5	76	
18-21	B ₁	—	.1	.1	.3	1.4	61.9	36.2	31.3	32.2	5.8	.52	.54	9.6	31.8	15.2	8.7	7.0	0.3	0.5	76	
21-25	B ₁	—	.1	.1	.4	1.4	63.5	34.5	37.1	32.0	5.6	.41	.47	8.7	31.0	15.2	8.3	6.7	0.3	0.5	76	
25-28	B ₁	—	.1	.1	.3	1.3	65.3	32.9	34.4	32.4	5.6	—	—	—	28.5	14.4	8.1	5.2	0.3	0.5	82	
28-31	B ₁	—	.2	.3	.5	1.4	64.5	33.1	33.2	33.0	5.7	—	—	—	30.5	15.4	8.9	5.4	0.3	0.5	82	
31-35	B ₁	—	.1	.1	.3	1.5	65.2	32.7	33.4	33.5	5.8	—	—	—	28.5	15.0	8.2	4.4	0.4	0.5	84	
35-39	B ₁	—	.1	.1	.3	1.3	65.8	32.3	34.3	33.0	6.1	—	—	—	29.3	15.2	8.4	4.5	0.4	0.5	84	
39-43	B ₁	—	.1	.1	.3	1.4	65.3	32.7	34.4	32.5	6.1	—	—	—	29.4	15.7	8.5	4.3	0.4	0.5	85	
43-48	B ₁	—	.1	.1	.3	1.2	65.9	32.5	34.2	33.1	6.3	—	—	—	29.7	15.5	8.6	4.6	0.4	0.5	84	
48-54	C ₁	—	.1	.1	.4	1.3	67.7	30.3	37.6	31.6	6.3	—	—	—	27.8	14.9	8.1	3.9	0.4	0.5	86	
54-60	C ₁	—	.1	.1	.3	1.5	68.8	29.1	39.9	30.6	6.4	—	—	—	26.6	14.5	8.0	3.3	0.3	0.5	88	
60-66	C ₁	—	.1	.1	.4	1.1	69.3	28.9	36.0	34.6	6.4	—	—	—	27.4	14.7	8.1	3.6	0.3	0.5	86	
66-72	C ₁	—	.1	.1	.3	1.2	69.8	28.4	36.3	34.9	6.4	—	—	—	26.4	14.3	7.9	3.4	0.3	0.5	87	

PROFILE E. CULTIVATED (PL. V: I.32. 5.34)

0-6	A ₁ P	0.1	0.3	0.3	0.5	1.2	64.5	33.1	35.9	30.1	6.4	2.16	.194	11.1	30.1	16.7	4.7	7.9	—	0.8	73
6-9	A ₁ B ₁	—	.2	.2	.4	1.1	62.3	35.3	33.1	30.5	5.2	1.99	.180	11.0	29.5	16.2	5.1	11.6	—	0.6	61
9-12	A ₁ B ₁	—	.2	.2	.5	1.1	61.2	36.8	31.4	31.2	5.3	1.75	.152	11.5	29.4	15.3	5.5	10.8	—	0.6	63
12-15	A ₁ B ₁	—	.3	.3	.4	1.2	59.8	38.0	29.8	31.4	5.4	1.44	.125	11.5	30.0	15.2	5.5	10.8	—	0.6	67
15-19	B ₁	—	.2	.2	.4	.9	59.7	38.6	30.7	30.1	5.6	1.08	.95	11.4	31.3	15.2	5.5	10.8	—	0.6	71
19-22	B ₁	—	.2	.2	.4	.9	59.5	38.8	29.1	31.5	5.8	.80	.73	11.0	32.0	15.2	5.5	10.8	—	0.6	76
22-26	B ₁	—	.1	.1	.3	1.1	60.3	38.0	29.7	31.9	5.8	.61	.60	10.2	31.9	15.2	5.5	10.8	—	0.6	77
26-30	B ₁	—	.1	.1	.3	1.3	61.1	37.1	31.4	31.2	5.8	.44	.48	9.2	31.6	15.5	5.5	10.8	—	0.6	80
30-33	B ₁	—	.1	.1	.2	1.3	63.6	34.7	33.1	31.9	5.7	—	—	—	30.8	15.2	5.6	6.1	—	0.6	80
33-36	B ₁	—	.1	.1	.2	1.4	64.2	33.6	34.6	31.0	5.7	—	—	—	30.1	14.9	5.6	5.9	—	0.6	80
36-39	B ₁	—	.1	.1	.3	1.3	64.0	34.2	32.2	33.3	5.9	—	—	—	30.4	15.2	5.6	5.7	—	0.6	81
39-43	B ₁	—	.1	.1	.4	1.4	65.0	32.9	34.9	31.7	5.9	—	—	—	31.0	15.9	5.8	5.4	—	0.6	82
43-48	C ₁	—	.1	.1	.4	1.4	64.7	33.2	34.0	32.3	5.8	—	—	—	30.7	15.9	5.8	5.1	—	0.6	83
48-54	C ₁	—	.1	.1	.3	1.2	66.0	32.3	33.9	33.5	6.2	—	—	—	30.2	15.9	5.8	4.3	—	0.6	86
54-60	C ₁	—	.1	.1	.5	1.3	67.3	30.5	31.5	37.4	6.0	—	—	—	29.9	15.4	5.4	4.3	1.3	0.6	86
60-66	C ₁	—	.1	.1	.5	1.5	68.6	29.1	35.9	34.5	6.3	—	—	—	28.4	15.0	5.4	3.9	0.6	0.6	86
66-72	C ₁	—	.1	.1	.6	1.1	69.7	28.3	34.5	38.7	6.2	—	—	—	26.6	14.2	5.0	3.4	0.4	0.6	87

LANDSCAPE EVOLUTION IN SOUTHWESTERN IOWA

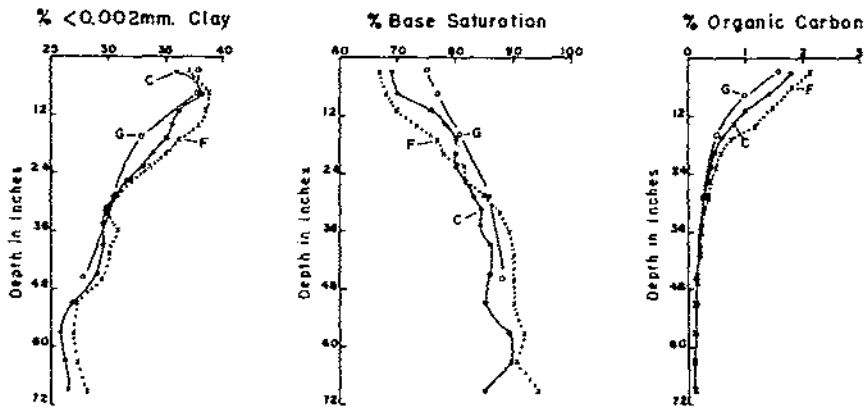

FIGURE 72.—Distribution with depth of clay (0.002 mm.), percent base saturation, and organic carbon of soils in post-Farmdale loess under the late Wisconsin-Recent surface. Note: Unit 11 soils, C and G; unit 13 soil, F.

A unit 11 Sharpsburg silty clay loam on a convex slope has the following morphology:

Profile C, unit 11, Sharpsburg silty clay loam (fig. 70; pl. V: C.37, 3.91): Slope 6 percent, convex; cultivated field.

- A_{1P} 0-6 inches Very dark brown (10YR 2/2) medium silty clay loam; cloddy; friable; leached Tazewell loess; clear boundary.
- AB 6-9 inches Very dark grayish brown (10YR 3/2) and brown (10YR 4/3) medium silty clay loam; weak fine subangular blocky structure; friable; gradual boundary.
- B₂₁ 9-12 inches Dark brown (10YR 3/3) medium silty clay loam with few very dark grayish brown (10YR 3/2) coats; weak to moderate fine subangular blocky structure; thin discontinuous clay skins; friable; gradual boundary.
- B₂₂ 12-21 inches Brown (10YR 5/3) grading to dark brown (10YR 4/3) medium silty clay loam; few fine faint gray and browner mottles in the lower 2 inches of this horizon; weak to moderate fine subangular blocky structure; thin discontinuous clay skins; friable; gradual to diffuse boundary.
- B₃ 21-36 inches Dark grayish brown (10YR 4/2) light silty clay loam; few fine grayish brown (2.5Y 5/2) and strong brown mottles and few fine distinct dark oxide concretions; weak medium blocky structure; friable; diffuse boundary.
- C₁₁ 36-66 inches Variegated grayish brown (2.5Y 5/2) and dark grayish brown (10YR 4/2) heavy silt loam to light silty clay loam; massive with a tendency for very weak coarse prismatic structure; friable; gradual boundary.
- C₁₂ 66-72 inches Light brownish gray (2.5Y 6/2) light silty clay loam; common fine and medium, distinct strong brown mottles grading to dark reddish brown; massive; moderately friable. This horizon is the lower deoxidized and leached zone.

Clay skins in the B horizons of unit 11 profiles are thin and discontinuous to continuous but they are not conspicuous. Thin sections of profile G were studied and clay skins were seen in the C₁ horizon (see appendix). The AB horizon, however, had the largest amount of segregated clay as old, distorted former clay skins, though there are few clay skins now on ped faces. Figure 72 and tables 31 and 32 show the distribution of several properties with depth in the soils of the late Wisconsin-Recent surface.

TABLE 31.—Analysis of Sharpsburg silty clay loam (unit 11)

PROFILE C, CULTIVATED (PL. V: C.37, 3.19)

Depth (inches)	Horizon	Size class and particle diameter										Textural class	pH	Organic carbon	Nitrogen	C/N	CaCO ₃ equivalent	Cation-exchange capacity (sum)	Extractable cations					Degree of base saturation
		Very coarse sand (2-1 mm)	Coarse sand (1-0.5 mm)	Medium sand (0.5-.25 mm)	Fine sand (0.25-.10 mm)	Very fine sand (0.10-.05 mm)	Silt (0.05-.002 mm)	Clay (<0.002 mm)	0.2-.02 mm	0.02-.002 mm	>2 mm								Ca	Mg	H	Na	K	
0-6	A ₁ P	0.1	0.2	0.1	0.3	1.5	61.9	35.9	35.1	28.5	-----	5.9	1.80	.152	11.1	-----	27.7	15.4	3.0	8.5	0.2	0.7	69	
6-9	A ₂ B ₁	---	.1	.1	.2	1.4	60.1	38.1	31.8	29.8	-----	5.7	1.40	.124	11.3	-----	27.9	14.8	3.9	8.5	.2	.4	70	
9-12	B ₂₁	---	.1	.1	.1	1.1	61.5	36.9	31.6	31.3	-----	5.7	1.00	.96	10.4	-----	32.4	15.8	8.1	7.7	.2	.6	76	
12-15	B ₂₂	---	---	---	.2	1.0	63.1	35.5	31.3	32.0	-----	5.8	.78	.77	10.1	-----	32.5	16.4	8.4	6.9	.2	.6	78	
15-18	B ₂₂	---	---	---	---	.8	64.2	35.0	31.9	33.1	-----	6.1	.56	.62	9.0	-----	31.8	16.4	8.4	6.1	.3	.6	80	
18-21	B ₂₂	---	---	---	.1	.6	65.5	33.8	31.7	34.5	-----	5.9	.47	.53	8.9	-----	27.9	14.2	7.2	5.6	.3	.6	80	
21-24	B ₃	---	---	---	.1	.6	66.2	33.1	32.4	34.5	-----	5.9	---	---	---	-----	28.1	13.8	7.7	5.6	.4	.6	80	
24-27	B ₃	---	---	---	.1	.9	67.4	31.6	33.9	34.5	-----	5.9	---	---	---	-----	29.0	14.8	8.1	5.2	.3	.6	82	
27-30	B ₃	---	---	---	.1	.9	68.3	30.8	33.2	36.0	-----	6.0	---	---	---	-----	29.1	15.3	8.1	4.8	.3	.6	83	
30-33	B ₃	---	---	---	.1	.7	69.5	29.7	35.8	34.5	-----	6.1	---	---	---	-----	28.9	15.5	7.9	4.6	.3	.6	84	
33-36	B ₃	---	---	---	.1	.7	69.6	29.6	33.8	36.6	-----	6.1	---	---	---	-----	29.0	15.5	7.9	4.6	.4	.6	84	
36-42	C ₁	---	---	---	.1	.8	69.5	29.6	36.2	34.2	-----	6.2	---	---	---	-----	28.9	15.2	8.8	3.9	.4	.6	86	
42-48	C ₁	---	---	.1	.3	1.1	69.2	29.3	38.8	31.7	-----	6.3	---	---	---	-----	27.9	15.2	7.8	3.9	.4	.6	86	
48-54	C ₁	---	---	.1	.4	1.4	71.4	26.7	40.8	32.3	-----	6.4	---	---	---	-----	26.3	14.1	7.3	3.9	.4	.6	85	
54-60	C ₁	---	.1	.2	.6	1.7	71.7	25.7	41.1	32.7	-----	6.5	---	---	---	-----	23.4	13.0	7.0	2.5	.4	.5	89	
60-66	C ₁	---	.1	.5	1.6	1.6	71.5	26.2	41.2	32.2	-----	6.5	---	---	---	-----	23.4	13.2	6.9	2.6	.3	.4	89	
66-72	D	---	.1	.1	.3	.8	72.1	26.6	37.8	35.3	-----	6.5	---	---	---	-----	26.0	13.7	7.5	3.9	.4	.5	85	

PROFILE G, CULTIVATED (PL. V: L.55, 4.34)

0-5	A ₁ P	0.0	0.1	0.2	0.4	0.8	60.7	37.8	31.6	30.1	<1	sicl	6.1	1.59	-----	-----	33.9	17.7	7.3	8.3	0.1	0.5	75
5-9	A-B	.0	.0	.1	.3	.6	61.4	37.6	30.5	31.6	<1	sicl	5.8	.98	-----	-----	33.3	17.0	8.1	7.6	.1	.5	77
9-22	B ₂	.0	.0	.0	.0	.0	67.3	32.7	32.4	34.9	<1	sicl	6.0	.44	-----	-----	30.8	16.1	8.2	5.8	.1	.6	81
22-37	B ₂	.0	.0	.1	.2	.6	68.6	30.5	30.9	38.4	<1	sicl	6.2	.23	-----	-----	29.2	16.3	8.1	4.0	.3	.6	86
37+	C	.0	.0	.1	.3	.6	71.2	27.8	37.8	34.2	<1	sicl/sil	6.2	.14	-----	-----	27.2	14.7	8.1	3.4	.4	.6	88

TABLE 32.—Analysis of Sharpsburg silty clay loam, deoxidized substratum
PHASE (UNIT 13), PROFILE F, CULTIVATED (PL. V: C.56, 4.5)

Depth (in- ches)	Hori- zon	Size class and particle diameter									pH	Or- ganic car- bon	Nitro- gen	C/N	CaCC- equiv- alent	Cat- ion- ex- change cap- acity (sum)	Extractable cations					De- gree of base satura- tion
		Very coarse sand (2-1 mm)	Coarse sand (1- 0.5 mm)	Medi- um sand (0.5- .25 mm)	Fine sand (0.25- .10 mm)	Very fine sand (0.10- .05 mm)	Silt (0.05- .002 mm)	Clay (<0.002 mm)	0.2- .02 mm	0.02- .002 mm							Ca	Mg	H	Na	K	
		Per- cent 0.1	Per- cent 0.2	Per- cent 0.1	Per- cent 0.3	Per- cent 1.8	Per- cent 60.7	Per- cent 36.8	Per- cent 33.8	Per- cent 28.9							Per- cent 5.7	Per- cent 2.15	Per- cent .201	Per- cent 10.7	Per- cent 33.6	
0-6	A ₁ P	—	.1	.1	.2	1.0	59.8	38.8	31.3	29.6	5.6	1.80	.154	11.7	33.5	14.6	7.5	10.5	.3	.8	67	
6-9	A ₁₂	—	.1	.1	.2	1.1	60.1	38.4	31.6	29.7	5.7	1.48	.131	11.3	34.7	15.5	7.7	10.3	.3	.8	68	
9-12	A ₃ B ₁	—	.1	.1	.2	1.1	60.7	37.8	31.6	30.3	5.8	1.16	.106	10.9	32.4	15.1	7.9	8.7	.3	.4	70	
12-15	B ₂	—	.1	.1	.2	1.1	62.4	36.1	31.9	31.6	5.8	.74	.74	10.0	31.7	15.3	8.3	7.2	.3	.6	73	
15-18	B ₂	—	.2	.1	.2	1.1	63.4	35.0	32.1	32.5	6.0	.59	.64	9.2	32.0	15.5	8.7	6.9	.3	.6	77	
18-21	B ₂	—	.4	.2	.2	1.1	64.5	33.6	31.8	33.9	6.2	.47	.54	8.7	30.3	15.6	8.5	5.4	.3	.6	78	
21-24	B ₂	—	.4	.4	.5	1.1	65.6	32.0	32.6	34.4	6.2	—	—	—	31.0	15.8	8.7	5.6	.3	.6	82	
24-27	B ₂	—	.3	.2	.3	1.2	67.3	30.7	33.5	35.2	6.5	—	—	—	28.0	15.2	7.9	4.1	.3	.6	85	
27-30	B ₂	—	.1	.1	.2	1.0	68.8	29.8	35.9	34.0	6.6	—	—	—	26.9	15.1	7.9	3.1	.3	.6	88	
30-34	B ₂	—	.1	.1	.2	1.0	67.7	30.9	34.7	34.1	6.6	—	—	—	26.9	15.0	8.1	2.9	.3	.6	89	
34-38	C ₁	—	.2	.2	.3	1.3	67.9	30.1	35.2	34.2	6.7	—	—	—	26.0	15.5	8.1	2.8	.3	.6	90	
38-43	C ₁	—	.2	.1	.3	1.1	68.8	29.5	35.5	34.6	6.9	—	—	—	26.4	15.1	7.8	2.6	.3	.6	90	
43-48	C ₁	—	.2	.2	.4	1.1	70.8	27.3	36.7	35.4	7.0	—	—	—	26.1	15.0	7.7	2.5	.3	.6	92	
48-54	C ₁	—	.2	.2	.5	1.3	70.8	27.0	39.4	33.0	7.0	—	—	—	25.7	14.8	7.9	2.1	.3	.6	90	
54-60	C ₁	—	.3	.3	.8	1.9	69.3	27.4	38.4	33.3	7.1	—	—	—	26.2	14.4	7.7	2.3	.3	.6	91	
60-66	C ₁	—	.1	.2	.5	1.2	69.8	28.2	37.6	33.7	6.9	—	—	—	25.1	14.9	7.7	1.6	.3	.6	94	

The morphology of a unit 13 Sharpsburg silty clay loam soil is:

Profile F, unit 13, Sharpsburg silty clay loam (fig. 70; pl. V: C.56, 4.51): Slope 6 percent, slightly concave; cultivated field.

A _{1P} 0-6 inches	Black (10YR 2/1) medium silty clay loam; weak medium to fine blocky (fragmental) structure; friable; leached Tazewell loess; clear boundary.
A ₁₂ 6-12 inches	Very dark brown (10YR 2/2) light to medium silty clay loam; moderate fine subangular blocky and fine to very fine granular structure; friable; gradual boundary.
AB 12-15 inches	Mixed very dark brown and dark grayish brown (10YR 2/2 and 10YR 4/2) light to medium silty clay loam; moderate fine and very fine subangular blocky structure; friable; gradual boundary.
B ₂ 15-21 inches	Dark brown (10YR 3/3) medium to light silty clay loam; few fine faint grayish brown and dark yellowish brown (10YR 5/2 and 10YR 4/4) mottles; moderate to weak fine subangular blocky structure; thin discontinuous clay skins; gradual boundary.
B ₃ 21-38 inches	Dark grayish brown (10YR 4/2) medium to light silty clay loam; common fine and medium grayish brown (2.5Y 5/2) and strong brown grading to yellowish red and dark reddish brown mottles; weak to moderate fine and medium blocky structure; thin discontinuous clay skins; friable; diffuse boundary.
C ₁ 38-72 inches	Grayish brown (2.5Y 5/2) light silty clay loam; common prominent strong brown to yellowish red and dark reddish brown mottles; weak coarse prismatic structure; vertical faces of the prisms extend to 6 feet and at this depth are very coarse; moderately friable.

The A horizons of unit 13 profiles are 5 to 12 inches thick and are very dark brown (10YR 2/2) to very dark gray (10YR 3/1). The B₂ horizons are dominantly dark brown (10YR 3/3) but are often mottled in the lower part. The B₃ horizons are dark grayish brown (10YR 4/2) to dark brown (10YR 4/3 to 3/3), but the interiors of many peds are grayish brown (2.5Y 5/2) like the C horizon. This grayish brown C horizon is the characteristic feature of this unit.

The drainage class of this unit depends upon the topographic position and the loess zone it is in. All unit 13 profiles, saddle or valley slope sites; have gray colors in the C horizon and they are in the lower grayish brown subzone of the loess. Thus the gray colors are inherited. But drainage is impeded by the fine-textured paleosol that underlies the lower deoxidized zone. The paleosol surface usually slopes from the center of the divides to its outcrop. If the level area of the divide is large, soils in loess above the paleosol outcrop would be influenced by seepage water moving laterally over the paleosol and they would be moderately well drained. In areas not thus influenced by the paleosol the soils would be well drained in spite of their color.

Soils on Valley Slopes in Kansan Till

Soils in Kansan till, excluding paleosols, formed after late Wisconsin-Recent dissection. Excluding the alluvial valley, these soils cover 50 percent of the area below paleosol outcrops. Their topography is made up of convex to straight valley slopes and low level spur ridges that have slopes of 6 to 20 percent (pl. V, 21A, 21, 22, 23, 24). Kansan till has a range in texture from light clay loam to sandy loam. Sand lenses of varying thickness occur within or below the soil. The depth to carbonate in some areas

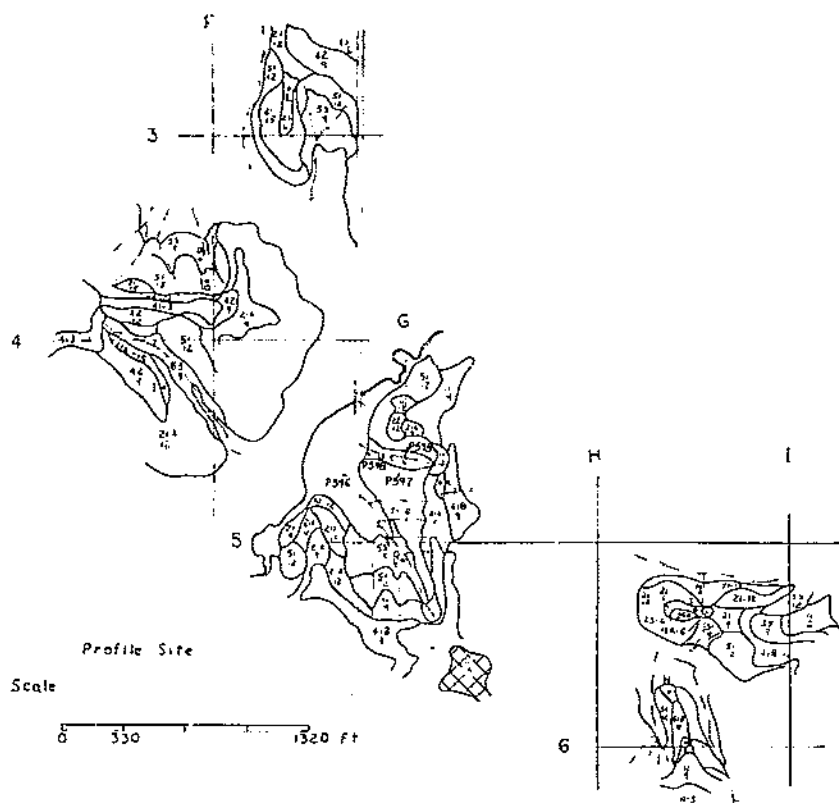

FIGURE 73.—Location of soils in Kansan till and valley-side alluvium. The hatched area is Tazewell surface, uneroded and stable. All other non-alluvial surfaces were eroded in late Wisconsin or Recent time.

ranges from 12 to 96 inches in a horizontal distance of 5 to 10 feet.

Five soils in Kansan till were mapped. Four of the mapping units, 21A, 21, 23, and 24, designate soils with different depth to carbonate and degree of profile development. Unit 22 includes soils in coarse-textured till. Earlier work (57, pp. 48-51) recognized various slope phases of the Shelby series but not these depth to carbonate units.

The morphological properties of unit 21A, Shelby clay loam, deep to carbonate phase (fig. 73, H); unit 21, Shelby clay loam, moderately shallow to carbonate phase (fig. 73, J); and unit 23, Shelby-Steinauer intergrade (fig. 73, L) are given in the following descriptions:

Profile H, unit 21A, Shelby clay loam (fig. 73; pl. V: H.37, 5.73): Slope 12 percent, convex; bluegrass.

A₁₁ 0-4 inches Very dark brown (10YR 2/2) medium silty clay loam to clay loam; moderate to strong very fine granular structure; friable; leached Kansan till; clear boundary.

A₁₂ 4-9 inches Very dark brown (10YR 2/2) medium silty clay loam to medium clay loam; moderate to strong fine granular structure; friable to firm; clear boundary.

- AB 9-13 inches Very dark grayish brown (10YR 3/2) medium clay loam to medium silty clay loam with some mixing of dark brown (10YR 4/3); moderate fine subangular blocky structure; friable to slightly firm; gradual boundary.
- B₂₁ 13-22 inches Dark brown (10YR 4/3) heavy clay loam; moderate fine subangular blocky structure; thin continuous clay skins; firm; gradual boundary.
- B₂₂ 22-30 inches Dark brown to dark yellowish brown (10YR 4/3 to 10YR 4/4) heavy clay loam; few fine strong brown mottles; weak to moderate fine and medium subangular blocky structure; medium continuous clay skins; firm; gradual boundary.
- B₃₁ 30-37 inches Dark grayish brown to dark brown (10YR 4/2.5) medium to heavy clay loam; weak medium blocky structure; interior of peds are grayish brown, dark yellowish brown, and strong brown (2.5Y 5/2, 10YR 4/4, and 7.5YR 5/6); thin to medium continuous clay skins; firm; gradual boundary.
- B₃₂ 37-43 inches Dark grayish brown to dark brown (10YR 4/2.5) medium clay loam; few fine to medium grayish brown and strong brown (2.5Y 5/2 and 7.5YR 5/6) mottles; weak medium to coarse blocky structure; thin continuous clay skins on vertical surfaces and thin discontinuous clay skins on horizontal surfaces; firm; abrupt boundary.
- B₃₃ 43-54 inches Dark grayish brown (10YR 4/2) medium clay loam; common olive gray to gray (5Y 4/2 to 5/1) streaks which range up to 2 inches long and $\frac{1}{4}$ inch wide; common fine to medium strong brown (7.5YR 5/6) mottles; very weak medium and coarse blocky structure; thin continuous clay skins on vertical surfaces and thin discontinuous clay skins on horizontal surfaces; calcareous Kansan till; few white firm carbonate concretions less than $\frac{1}{4}$ inch in diameter; diffuse boundary.
- C 54+ inches Variegated dark grayish brown to brown and grayish brown (10YR 4/2.5 and 2.5Y 5/2) light clay loam; common fine and coarse strong brown (7.5YR 5/7), few to common fine and coarse yellowish red (5YR 4/6) and few fine olive brown (2.5Y 4/4) mottles; massive; thin discontinuous clay skins on vertical cleavage planes; calcareous Kansan till; common carbonate concretions less than $\frac{1}{4}$ inch in diameter.

Profile J, unit 21, Shelby clay loam (fig. 73; pl. V: H.52, 5.33): Slope 4 percent, convex; mixed bluegrass and timothy pasture.

- A₁ 0-6 inches Very dark brown (10YR 2/2) medium clay loam to medium silty clay loam; weak to moderate fine granular structure; friable; leached Kansan till; clear boundary.
- AB 6-10 inches Very dark grayish brown (10YR 3/2) medium clay loam to medium silty clay loam with some mixing of black and dark brown (10YR 2/1 and 3/3); moderate fine and very fine subangular blocky structure; friable; clear boundary.
- B₂ 10-19 inches Dark brown (10YR 4/3) medium clay loam with some mixing of very dark grayish brown and very dark brown (10YR 3/2 and 2/2) along vertical channels; moderate fine subangular blocky structure; thin to medium continuous clay skins; slightly firm; clear boundary.
- B₃₁ 19-33 inches Brown (10YR 5/3) medium clay loam; few to common fine and medium gray (5Y 5/1) and few fine strong brown mottles; weak medium blocky structure; thin continuous clay skins; firm; abrupt boundary.
- B₃₂ 33-48 inches Dark yellowish brown (10YR 4/4) light to medium clay loam; common medium to coarse gray (5Y 5/1) mottles and streaks; weak medium to coarse blocky structure; thin continuous clay skins becoming discontinuous in the lower part of the horizon; firm; calcareous Kansan till; common white soft to very hard carbonate concretions and limestone fragments less than $\frac{3}{4}$ inch in diameter; gradual to diffuse boundary.
- C 48-60 inches Brown (10YR 5/3) light to medium clay loam; common gray (5Y 5/1) streaks less than $\frac{1}{2}$ inch wide; common fine to coarse strong brown (7.5YR 5/6) mottles; massive; thin discontinuous clay skins on vertical cleavage planes; firm; calcareous; many white soft to very hard carbonate concretions and limestone fragments less than 1 inch in diameter.

Profile L, unit 23, Shelby-Steinauer intergrade (fig. 73; pl. V: F.4, 2.76): Slope 4 percent, convex; bluegrass.

A ₁ 0-6 inches	Very dark brown (10YR 2/2) light clay loam; dark gray (10YR 4/1) dry; weak to moderate fine granular structure; friable; leached Kansan till; clear boundary.
AB 6-10 inches	Very dark grayish brown (10YR 3/2) medium clay loam with some mixing of dark brown (10YR 4/3); dark grayish brown (10YR 4/2) dry; moderate fine and very fine subangular blocky structure; friable; clear boundary.
B ₂₁ 10-14 inches	Dark brown (10YR 4/3) medium clay loam with an appreciable mixing of very dark grayish brown (10YR 3/2) and some dark brown (10YR 4/3); moderate fine subangular blocky structure; thin continuous clay skins; friable; leached, but contains few white carbonate concretions < 1/8 inch in diameter; abrupt boundary.
B ₂₂ 14-19 inches	Dark brown (10YR 4/3) medium clay loam with some mixing of yellowish brown (10YR 5/4) and very dark grayish brown (10YR 3/2) colors that appear to be worm channel fillings; few fine dark brown (7.5YR 4/4 to 4/6) mottles; few fine moderate fine subangular blocky structure; thin continuous clay skins; friable; calcareous Kansan till; common white carbonate concretions with a maximum diameter of 1/2 inch and a range of consistence from soft to hard; gradual boundary.
B ₃₁ 19-28 inches	Dark brown and yellowish brown (10YR 4/3 and 5/4) light to medium clay loam; few fine grayish brown and dark brown (2.5Y 5/2, 7.5YR 4/4 and 4/6) mottles; weak medium to fine subangular blocky structure; thin continuous to discontinuous clay skins; friable; calcareous; many white carbonate concretions and limestone fragments loose to hard in diameter; < 1/8 inch to 1 inch and in consistence from loose to hard; gradual boundary.
B ₃₂ 28-34 inches	Brown (10YR 4/3 to 5/3) light clay loam; few gray (5Y 5/1) streaks 1/4 inch wide and 2 to 4 inches long; arrangement is both horizontal and vertical; few strong brown (7.5YR 5/8) streaks 1 to 2 inches wide with a vertical orientation; these streaks extend from the top of the B ₃₂ to the C horizon; few distinct dark oxides on structural aggregates; weak medium to coarse blocky structure; discontinuous thin clay skins; firm; calcareous; many white carbonate concretions and limestone fragments < 1/8 to 3/4 inch in diameter; soft to hard; gradual boundary.
C 34-48 inches	Variiegated brown to yellowish brown (10YR 5/3 to 5/4) light clay loam; few medium to coarse brown to dark brown mottles; massive; firm; calcareous; common white carbonate concretions and limestone fragments < 1/8 to 1/2 inch in diameter.

Although depth to carbonate is greater than 40 inches in unit 21A, 20 to 40 inches in unit 21, and less than 20 inches in unit 23, these soils have morphological properties common to most Brunizems (65, p. 159). A transition horizon occurs between the A and B horizons (fig. 74), and the structure of the B horizon is weak to moderate. The boundary between the dark brown B horizon and the C horizon is diffuse in units 21A and 21, but in unit 23 the B horizon may extend downward into calcareous material.

The horizontal and vertical variability in texture of Kansan till is much greater than it is in loess and accounts in part for the textural differences between and within mapping units (fig. 75, tables 33, 34, and 35). The variation in depth and amount of carbonate of the till influences the base-saturation curves.

Except for a thinner solum in unit 23 than in unit 21A or 21, the major field difference found among the soils was the depths to carbonate. The units are closely associated on the landscape in an apparently random pattern (pl. V). In one pit (soil K) there were carbonates at depths of 17 to 32 inches so units 21 and 23 were present in the same pit.



FIGURE 74.—A, Shelby clay loam (unit 21A) profile H. B, Shelby-Steinauer intergrade (unit 23) profile M.

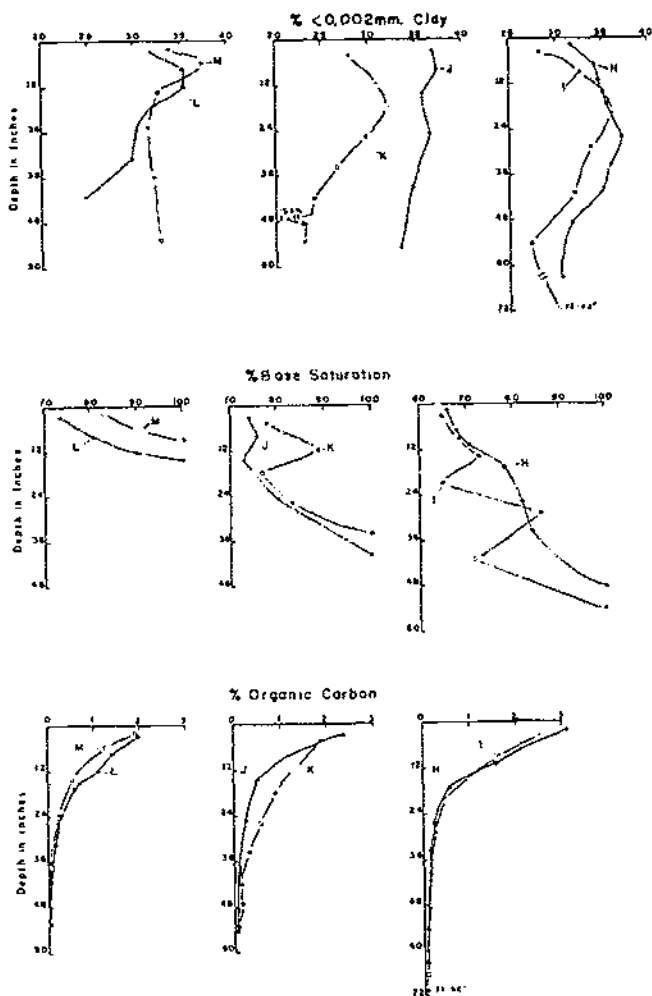

FIGURE 75.—Distribution with depth of the clay, percent base saturation, and organic carbon of profiles in Kansan till. L and M, unit 23 profiles; J and K, unit 21; H and I, unit 21A.

The following observations indicate that depth to carbonate is due to variation in the parent material and not to slope or landscape position: (1) No slope group or topographic position has a single depth to carbonate (pl. V: 21A, 21, 23, 24). (2) The depth to carbonate differs on the same valley slope or spur ridge summit (pl. V: H.0, 4.5, 21A, 21, 23; H.52, 5.33-H.48, 5.36). (3) The steeper slopes may be leached free of carbonate to greater depths than adjoining slopes of lesser gradient (pl. V: H.37, 5.73-H.48, 5.36). (4) Where the depth to carbonate is greater the carbonate content, in general, is smaller (tables 34, 35).

TABLE 33.—Analysis of Shelby clay loam, deep to carbonate (unit 21A)

PROFILE H, BLUEGRASS (PL. V: H.37, 5.73)

Depth (inches)	Horizon	Size class and particle diameter										Textural class	pH	Organic carbon	Nitrogen	C/N	CaCO ₃ equivalent	Cation-exchange capacity (sum)	Extractable cations					Degree of base saturation
		Very coarse sand (2-1 mm)	Coarse sand (1-0.5 mm)	Medium sand (0.5-.25 mm)	Fine sand (0.25-.10 mm)	Very fine sand (0.10-.05 mm)	Silt (0.05-.002 mm)	Clay (<0.002 mm)	0.2-.02 mm	0.02-.002 mm	>2 mm								Ca	Mg	H	Na	K	
		Percent	Percent	Percent	Percent	Percent	Percent	Percent	Percent	Percent	Percent								meq/100g	meq/100g	meq/100g	meq/100g	meq/100g	
0-4	A ₁₁	0.4	1.7	2.8	5.8	4.2	53.4	31.7	35.9	24.8	<1	sicl	5.5	3.12	0.304	10.3	30.8	14.9	5.0	10.5	<0.1	0.4	66	
4-9	A ₁₂	.4	1.7	2.6	5.0	3.9	52.2	34.2	33.1	25.8	<1	sicl	5.6	2.06	.206	10.0	29.6	15.1	4.6	9.5	<0.1	.4	68	
9-13	A-B	.2	1.6	2.6	5.2	4.4	51.4	34.6	32.6	26.0	<1	sicl	5.6	1.59	.164	9.7	28.7	15.3	4.6	8.3	<0.1	.3	71	
13-22	B ₂₁	1.0	2.2	3.4	6.6	5.2	46.0	35.6	30.4	24.4	<1	sicl	5.7	.52	.065	8.0	26.3	14.7	5.4	5.0	.1	.4	78	
22-30	B ₂₂	1.7	3.6	5.4	10.9	8.1	33.2	37.1	27.7	19.5	<1	cl	5.9	-----	-----	-----	21.9	13.1	4.4	4.0	.1	.3	82	
30-37	B ₃₁	1.6	3.9	5.4	10.2	8.5	34.4	36.0	28.4	20.2	2	cl	6.0	-----	-----	-----	21.1	13.2	4.1	3.4	.1	.3	84	
37-43	B ₃₂	1.5	4.0	5.6	10.3	8.7	34.8	35.1	29.2	20.0	2	cl	6.6	-----	-----	-----	calca	reous	-----	-----	-----	-----	-----	-----
43-54	B ₃₃	2.1	4.6	5.5	10.4	9.3	36.4	31.7	31.5	20.3	2	cl	7.8	-----	-----	-----	calca	reous	-----	-----	-----	-----	-----	-----
54+	C	2.0	4.2	5.4	10.0	8.5	39.2	30.7	32.2	21.1	2	cl	7.8	-----	-----	-----	calca	reous	-----	-----	-----	-----	-----	-----
																		13.4	3.7	.0	.1	0.3	100	

PROFILE I, CULTIVATED (PL. I: E.74, 4.24)

0-7	A _{1p}	1.2	4.0	6.6	15.0	10.0	34.8	28.4	36.0	17.3	4	cl	5.6	2.50	0.221	11.6	26.1	13.1	3.4	9.1	0.1	0.4	65	
7-11	A-B	1.4	3.9	6.0	13.7	9.7	32.6	32.7	33.4	16.6	1	cl	5.5	1.85	.155	10.6	26.0	13.6	4.0	8.0	.1	.3	69	
11-17	B ₂₁	1.5	4.6	6.0	12.0	8.0	32.7	35.2	30.1	17.4	1	cl	5.4	1.02	.103	9.9	25.5	14.1	4.0	7.0	.1	.3	73	
17-23	B ₂₂	1.7	3.9	5.1	10.9	8.7	33.7	36.0	29.4	18.3	2	cl	5.7	.49	.056	8.8	29.4	14.4	4.1	10.4	.1	.4	65	
23-34	B ₃₁	1.2	4.2	5.7	11.9	9.2	33.9	33.9	31.0	20.0	2	cl	5.6	-----	-----	-----	21.5	14.5	3.5	3.1	.1	.3	80	
34-48	B ₃₂	2.0	4.3	5.6	11.3	8.3	36.4	32.1	31.0	20.9	1	cl	6.4	-----	-----	-----	26.3	16.0	2.6	7.3	.1	.3	72	
48-60	C ₂₁	2.2	4.3	5.6	13.0	11.0	36.5	27.4	34.6	20.8	2	cl/l	7.8	-----	-----	-----	calca	reous	-----	-----	-----	-----	-----	-----
72+	C ₂₃	1.8	4.4	5.4	10.9	9.1	38.2	30.2	31.2	22.5	3	cl	7.7	-----	-----	-----	calca	reous	-----	-----	-----	-----	-----	-----

TABLE 34.—Analysis of Shelby clay loam, moderately shallow to carbonate (unit 21)

PROFILE J, MIXED TIMOTHY AND BLUEGRASS (PL. V: H.52, 5.33)

Depth (inches)	Horizon	Size class and particle diameter										Textural class	pH	Organic carbon	Nitrogen	C/N	CaCO ₃ equivalent	Cation-exchange capacity (sum)	Extractable cations					Degree of base saturation
		Very coarse sand (2-1 mm)	Coarse sand (1-0.5 mm)	Medium sand (0.5-.25 mm)	Fine sand (0.25-.10 mm)	Very fine sand (0.10-.05 mm)	Silt (0.05-.002 mm)	Clay (<0.002 mm)	0.2-.02 mm	0.02-.002 mm	>2 mm								Ca	Mg	H	Na	K	
		Percent	Percent	Percent	Percent	Percent	Percent	Percent	Percent	Percent	Percent		Percent	Percent		Percent	meq/100g	meq/100g	meq/100g	meq/100g	meq/100g	meq/100g	Percent	
0-6	A ₁	0.6	2.0	2.7	4.8	3.6	49.5	36.8	29.8	25.8	<1	sicl	5.9	2.33	0.204	11.4	-----	33.1	18.8	5.0	8.7	0.1	0.5	74
6-10	A-B	.4	1.7	2.3	4.6	4.0	49.7	37.3	29.2	27.1	<1	sicl	5.6	1.18	.119	9.9	-----	32.2	17.9	5.7	8.0	.1	.5	75
10-19	B ₁	.9	2.8	4.0	8.2	6.5	42.0	35.6	30.8	22.2	2	el	5.8	.59	.062	8.1	-----	28.6	15.4	5.1	7.6	.1	.4	73
19-33	B ₁₁	1.3	8.0	2.6	9.8	7.5	34.3	36.5	26.2	21.0	1	el	6.2	-----	-----	-----	-----	23.7	14.8	3.8	4.7	.1	.3	80
33-48	B ₂	1.6	6.2	3.7	10.3	8.4	35.2	34.6	28.1	21.2	2	el	7.7	-----	-----	-----	6	calca	reous	-----	-----	-----	-----	-----
48+	C	1.8	5.7	4.2	9.9	7.8	37.2	33.4	28.8	21.7	2	el	7.7	-----	-----	-----	9	calca	reous	-----	-----	-----	-----	-----

PROFILE K, BLUEGRASS (PL. V: G.18, 4.17)

0-9	A ₁	1.6	6.6	6.1	15.1	10.1	32.5	28.0	35.3	15.6	2	el	5.6	1.88	0.158	11.9	-----	18.9	12.0	2.4	4.2	-0.1	0.3	78
9-14	A-B	2.2	5.6	6.7	14.1	9.7	30.9	30.8	32.7	15.7	3	el	5.8	1.30	.130	10.0	-----	18.3	13.3	2.6	2.0	.1	.3	89
14-22	B ₂₁	2.4	5.7	6.7	12.6	9.6	31.0	32.0	30.2	17.4	3	el	5.8	.88	.085	10.4	-----	21.2	13.5	2.4	4.9	.1	.3	77
22-29	B ₂₂	3.0	5.9	6.7	12.9	10.1	31.8	29.6	30.7	18.3	3	el	6.4	.59	.063	9.4	-----	19.9	14.1	2.9	3.4	.1	.3	83
29-37	B ₂₃	2.0	5.2	5.7	12.3	9.5	38.6	26.7	33.4	21.8	4	1/cl	7.8	-----	-----	-----	10	calca	reous	-----	-----	-----	-----	-----
37-46	B ₃	2.2	6.0	6.1	12.6	10.3	38.5	24.3	34.6	21.2	5	l	7.8	-----	-----	-----	10	calca	reous	-----	-----	-----	-----	-----
46-48	C ₁₁	1.1	2.4	2.6	16.3	23.4	38.8	15.4	58.9	15.3	-1	l	7.9	-----	-----	-----	7	calca	reous	-----	-----	-----	-----	-----
48+	C ₂	2.9	5.5	6.7	12.6	9.3	39.9	23.1	35.4	21.0	2	l	7.9	-----	-----	-----	11	calca	reous	-----	-----	-----	-----	-----

TABLE 35.—Analysis of Shelby-Steinauer intergrade (unit 23)

PROFILE L, BLUEGRASS (PL. V: F.4, 2.76)

Depth (inches)	Horizon	Size class and particle diameter										Textural class	pH	Organic carbon	Nitrogen	C/N	CaCO ₃ equivalent	Cation-exchange capacity (sum)	Extractable cations					Degree of base saturation
		Very coarse sand (2-1 mm)	Coarse sand (1-0.5 mm)	Medium sand (0.5-.25 mm)	Fine sand (0.25-.10 mm)	Very fine sand (0.10-.05 mm)	Silt (0.05-.002 mm)	Clay (<0.002 mm)	0.2-.02 mm	0.02-.002 mm	>2 mm								Ca	Mg	H	Na	K	
		Percent	Percent	Percent	Percent	Percent	Percent	Percent	Percent	Percent	Percent								meq/100g	meq/100g	meq/100g	meq/100g	meq/100g	
0-6	A ₁	1.3	4.8	6.5	12.7	9.2	33.7	31.8	32.7	17.2	3cl	5.9	1.99			24.8	14.6	3.2	6.6	<0.1	0.4	73		
6-10	A-B	2.2	3.9	5.6	11.2	8.6	33.2	35.3	31.1	17.0	2cl	6.2	1.38			25.3	17.1	2.9	4.9	.1	.3	81		
10-14	B ₂₁	1.7	4.3	5.5	11.0	9.4	32.6	35.5	29.5	18.5	2cl	7.0	1.12			27.3	22.4	1.8	2.7	.1	.3	90		
14-19	B ₂₂	3.0	4.1	5.3	10.4	9.0	35.8	32.4	28.8	21.7	4cl	7.7	.58		10	calca reous								
19-28	B ₂₁	3.0	4.9	5.2	10.3	7.7	38.7	30.2	30.0	22.1	4cl	7.8			13	calca reous								
28-34	B ₂₂	2.1	4.8	5.5	10.5	8.8	38.5	29.8	30.4	22.8	4cl	7.8			13	calca reous								
34+	C	2.4	4.9	6.1	12.1	9.8	40.0	24.7	34.4	22.2	3cl	7.8			12	calca reous								

PROFILE M, MIXED TIMOTHY AND BLUEGRASS (PL. V: H.48, 5.36)

0-4	A ₁	1.5	5.0	6.3	11.3	7.1	35.0	23.8	30.9	17.3	3cl	6.9	1.93			20.2	13.9	2.3	3.4	0.1	0.5	83
4-9	A-B	2.0	3.7	5.7	10.7	8.1	32.5	37.3	28.6	17.9	3cl	7.1	1.25			31.0	21.6	2.2	2.9	<.1	.4	91
9-18	B ₂₁	2.5	4.4	5.3	9.4	7.5	38.4	32.5	28.4	22.9	5cl	7.7	.54		13	calca reous						
18-29	B ₂₁	2.8	4.7	5.3	9.4	8.2	38.1	31.5	27.6	23.9	2cl	7.7			15	calca reous						
29-43	B ₂₂	2.4	4.5	5.4	9.7	8.8	37.1	32.1	28.5	22.9	3cl	7.8			12	calca reous						
43+	C	2.0	4.2	5.3	10.0	8.2	37.6	32.7	29.5	21.8	2cl	7.8			11	calca reous						

Shelby-Steinauer intergrade soils (L and M) have the clay maximum above the calcareous horizons and the decrease in the clay content is pronounced in the calcareous layers (fig. 75; table 35). The solum extends for a considerable depth into the calcareous material. Thin sections showed clay skins in the calcareous horizons (thin sections of profile L are described in the appendix). The clay maximum in the Shelby-Steinauer soils is higher in the solum and thinner than in the Shelby soils (fig. 75). The presence of carbonates, apparently, has not only delayed clay formation or release but also clay illuviation. Clay movement into calcareous horizons is indicated by clay skins but such movement probably is minor. Perhaps the clay itself acts as a carbonate-removing agent. Some of the increase in clay shown by analysis is relative; it is a result of removal of carbonate minerals in coarser size fractions and release of clay from carbonate-cemented aggregates.

The clay distribution in the profiles of soils derived from till is similar to that in the unit 11 and 13 profiles both in amount of clay in the clay maximum and in the depth range of the clay maximum. The presence of clay skins in and below the clay maximum indicates that clay illuviation has been active. In the till-derived soils as well as the Sharpsburg soils some of the clay maximum is due to weathering and release of clay. Clay movement, and weathering cause the clay maximum to move downward and become greater in degree and thickness. In the Shelby and related soils, since the depth and size of the clay maximum appears to be controlled by the lime content and texture of the till, it is difficult to assess the effect of age, topography, or erosion.

Ped faces in the AB horizons of soils K and L are free of clay, but the interiors of the peds contain an abundance of segregated oriented clay. This suggests that the AB horizon was a former B horizon that is now being degraded. Hence it is possible that some truncation has occurred.

The base saturation in the A and B horizons of soils in Kansan till, in general, is smaller where depth to carbonate is greater (fig. 75). This probably reflects differences in carbonate content of parent materials because age, vegetation, and climate of these soils are similar. In contrast to Sharpsburg soils, variation in slope gradient has had but little apparent influence on the degree of base saturation. Also, depths to the maximum clay, a pH of 5.7, and a base saturation value of 75 percent do not parallel each other as in the Sharpsburg soils.

OTHER SOILS IN KANSAN TILL

Shelby loam, sandy subsoil variant, and Steinauer clay loam, formed in Kansan till, do not occupy large areas and were not sampled for laboratory analyses.

Shelby loam, sandy subsoil variant (unit 22), is in areas of coarse-textured Kansan till (pl. V). The texture is a loam to sandy loam in the surface, but the B and C horizons are sandy, loams.

Steinauer clay loam (unit 24) is calcareous to the surface. It has little horizonation other than a dark (10YR 3/2) A horizon. In many places the surface has an accumulation of gravel.

Descriptions of these two units are given in the appendix.

Soils in Valley-Side Alluvium

Valley-side waterways are spoon-shaped and have ill-defined channels. They are numerous on the late Wisconsin-Recent valley slopes and range in slope from 4 to 15 percent (pl. V). Valley-side waterway alluvium occurs in and between these waterways (pl. V: G.O., 5.0) and between the junction of the valley fill and valley slopes. The slopes are 5 to 20 percent. The alluvium is 12 to about 40 inches thick in the concave and convex areas between the waterways; in and around the waterways it is 24 to 182 inches thick.

The alluvium is a light silty clay loam in areas where Tazewell loess is the source. It is a silt loam, loam, or clay loam where Kansan till is the main source. The thin alluvium between drainageways has relatively uniform texture with depth. The thicker alluvium in or around drainageways is more variable; its surface is a silty clay loam but in some places grades downward into clay loams, loams, or sandy clay loams. Poetsch⁴⁵ studied a sequence of soils along a valley-side waterway (fig. 73, P-595, P-596, P-597, P-598; Pl. V: F.97, 4.68-F.68, 4.67) and found progressive changes in the texture as the distance from the source increased (fig. 76).

Valley-side alluvium possibly is of Recent age because it overlies Kansan till, Tazewell loess, and late Sangamon paleosols. The stone line at the contact between the alluvium and the Kansan till can be traced from the valley slopes out under the alluvial fill in the valley of South Turkey Creek.

Stones at the contact between the alluvium and the underlying Kansan till are 2 to 80 mm. in diameter. If there is no stone line, the contact can be located by the differences in sand content and consistence. The alluvium feels silty and is very friable to friable whereas the till is gritty and firm.

Arbor and Olmitz silt loams were mapped in valley-side alluvium. Olmitz silt loam has a darker and thicker A horizon and lower chroma and value colors in the B horizon than the Arbor. The surface textures and the depth to Kansan till could not be used to separate them because these properties overlap.

Arbor silt loam (unit 51) is on the upper valley slopes. The upper part of the solum is in alluvium and the lower part in Kansan till. Hence it differs from the Shelby soils formed entirely in Kansan till. Soils like Arbor probably were included with Shelby in earlier mapping. The Olmitz silt loam (unit 53) is in and around the valley-side waterways on the lower parts of the valley slopes (pl. V: G.O., 5.0). It is on convex and concave slopes of 5 to 9 percent in alluvium 24 to 182 inches thick. An Arbor and an Olmitz profile are described in the following paragraphs.

⁴⁵ Poetsch, Ernst. Soil profile variation in alluvium: Unpublished M.S. Thesis, Iowa State College.

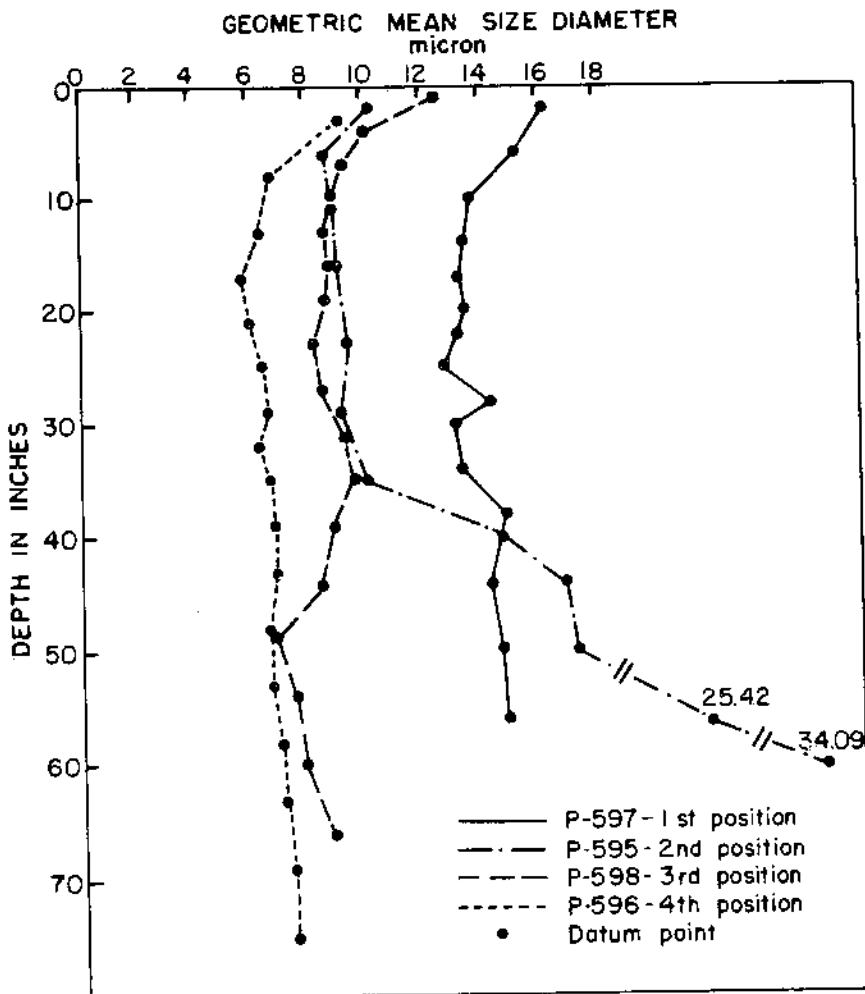

FIGURE 76.—Geometric-mean size diameter distribution with depth of profile P-597 (Arbor), P-595 and P-598 (Olmitz), and P-596 (unit 50). Data from Poetsch.

Profile N, unit 51, Arbor silt loam (fig. 73; pl. V: H.54, 5.24): Slope 12 percent; bluegrass.

- A₁₁ 0-5 inches Very dark brown (10YR 2/2) gritty light to medium silty clay loam; moderate to strong fine and very fine granular structure; friable valley-side alluvium; gradual boundary.
- A₁₂ 5-15 inches Very dark brown (10YR 2/2) gritty medium silty clay loam; strong fine and medium granular structure; friable; gradual boundary.
- AB 15-19 inches Very dark grayish brown (10YR 3/2) gritty medium silty clay loam to clay loam; moderate to strong fine subangular blocky structure; friable; clear boundary.
- B₂₁ 19-22 inches Mixed dark brown and very dark grayish brown (10YR 4/3 and 3/2) medium clay loam; moderate to strong fine subangular blocky structure; thin continuous clay skins; friable; abrupt boundary.

TB 1349 (1967) U.S.D.A. TECHNICAL BULLETINS
LANDSCAPE EVOLUTION AND SOIL FORMATION IN SOUTHWESTERN IOWA
RUHE, R. W., DANIELS, R. B., GADY, J. G. 20 P.

- B₂₁** 22-24 inches (stone line) Dark brown (10YR 4/3) medium clay loam with some mixing of very dark grayish brown (10YR 3/2); moderate fine subangular blocky structure; thin continuous clay skins; base of valley-side waterway alluvium; abrupt boundary. This horizon has a concentration of pebbles and few cobbles up to 5 inches in diameter.
- IIB₂₁** 24-34 inches Dark brown (10YR 4/3) medium clay loam; weak to moderate fine and medium subangular blocky structure; medium continuous clay skins; firm; leached Kansan till; gradual boundary.
- IIB₂₁** 34-45 inches Dark brown (10YR 4/3) medium clay loam; few fine grayish brown and strong brown (2.5Y 5/2 and 7.5YR 5/6) mottles; weak medium blocky structure; thin continuous clay skins; firm; clear boundary.
- IIB₂₁** 45-55 inches Dark yellowish brown (10YR 4/4) medium to light clay loam; few fine grayish brown, yellowish red and strong brown (2.5Y 5/2, 5YR 4/6 and 7.5YR 5/6) mottles; weak to very weak medium to coarse blocky structure; thin discontinuous clay skins; calcareous Kansan till; few carbonate nodules < 1/2 inch in diameter; gradual to diffuse boundary.
- IIC** 55-72 inches Dark yellowish brown (10YR 4/4) medium to light clay loam; common fine to coarse strong brown (7.5YR 5/6), few to common fine to medium grayish brown (2.5Y 5/2) and few fine and medium yellowish red (5YR 4/6) mottles; few fine dark oxides; massive; thin discontinuous clay skins along vertical cleavage planes; calcareous.
- Profile P, unit 53, Olmitz silt loam (fig. 73; pl. V: E.94, 3.6): Slope 9 percent, concave; cultivated field.**
- A₁₁** 0-8 inches Black (10YR 2/1) gritty light silty clay loam to heavy silt clay loam; black (10YR 2/1) crushed and dark gray (10YR 4/1) dry; weak medium granular structure; friable to very friable valley-side alluvium; clear boundary.
- A₁₂** 8-22 inches Black (10YR 2/1) gritty light silty clay loam; black to very dark gray (10YR 2/1 to 3/1) crushed, changing to very dark gray with depth; dark gray (10YR 4/1) dry; weak to moderate fine subangular blocky structure; friable; gradual boundary.
- AB** 22-29 inches Very dark brown (10YR 2/2) gritty light silty clay loam with some mixing of black (10YR 2/1); very dark grayish brown (10YR 3/2) crushed and very dark grayish brown (10YR 3/2) dry; weak fine subangular blocky structure; tendency for the peds to be arranged in very weak fine and medium prisms; friable; gradual boundary.
- B₂₁** 29-36 inches Very dark brown (10YR 2/2) gritty medium silty clay loam; few areas of black (10YR 2/1) along channels; very dark grayish brown (10YR 3/2) crushed, and dark grayish brown (10YR 4/2) dry; weak fine subangular blocky structure; thin discontinuous clay skins; friable; gradual boundary.
- B₂₂** 36-46 inches Very dark grayish brown (10YR 3/2) medium clay loam; very dark grayish brown (10YR 3/2) crushed; and dark grayish brown (10YR 4/2) dry; weak fine subangular blocky structure; thin continuous or discontinuous clay skins; peds are arranged in weak medium prisms; friable; clear boundary.
- B₂₃** 45-51 inches Very dark grayish brown (10YR 3/2) medium clay loam; weak fine and medium subangular blocky structure; thin discontinuous clay skins; firm; clear boundary. The depth to the upper boundary of the stone line ranges from 45 to 47 inches across the face of the pit. Stones range in diameter from 2 mm. to 10 inches; base of valley-side alluvium.
- IIB₂₁** 51-62 inches Dark yellowish brown (10YR 4/4) medium to heavy clay loam with some mixing of very dark grayish brown (10YR 3/2); weak medium blocky structure; thin continuous clay skins on vertical surfaces and thin discontinuous clay skins on horizontal surfaces; the clay skins are dark grayish brown (10YR 4/2); firm Kansan till; gradual boundary.
- IIC₁** 62-81 inches Dark brown (10YR 4/3) medium clay loam; common fine distinct gray (5Y 5/1) and few fine dark yellowish brown to dark brown mottles; massive; thin discontinuous clay skins on vertical cleavage faces; clear boundary.
- IIC₂** 81-93 inches Grayish brown (2.5Y 5/2) light clay loam; common medium to coarse gray (5Y 5/1) and dark brown (7.5YR 4/4) mottles; massive; calcareous.

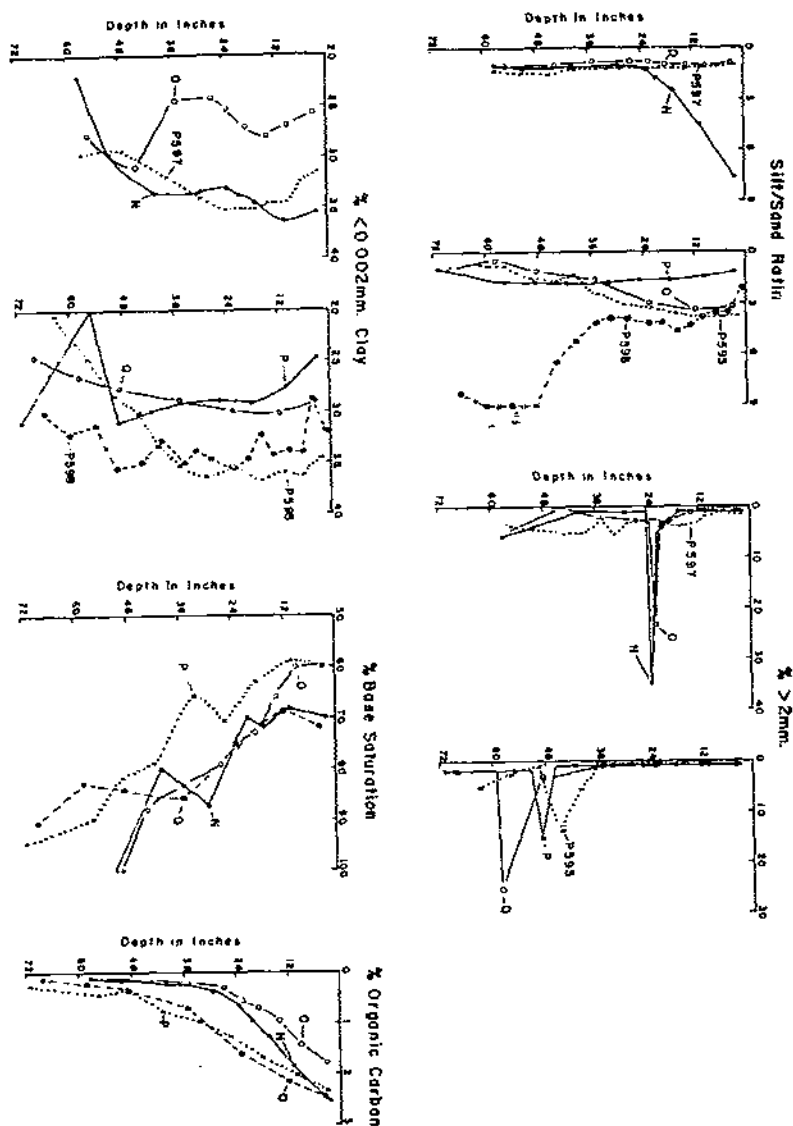

FIGURE 77.—Distribution with depth of the silt/sand ratios, percent gravel and clay, percent base saturation, and organic carbon of soils in valley-side alluvium. P-597, P-597, and P-598 are from Poetsch; N, O, and P-597 are unit 51 profiles; F, Q, P-595, and P-598 are unit 53 profiles.

TABLE 36.—Analysis of Arbor silt loam (unit 51)

PROFILE N (PL. V: H.54, 5.24)

Depth (inches)	Horizon	Size class and particle diameter										Ratio silt/sand	pH	Organic carbon	Nitrogen	C/N	CaCO ₃ equivalent	Cation-exchange capacity (sum)	Extractable cations					Degree of base saturation
		Very coarse sand (2-1 mm)	Coarse sand (1-0.5 mm)	Medium sand (0.5-.25 mm)	Fine sand (0.25-.10 mm)	Very fine sand (0.10-.05 mm)	Silt (0.05-.002 mm)	Clay (<0.002 mm)	0.2-.02 mm	0.02-.002 mm	>2 mm								Ca	Mg	H	Na	K	
		Percent	Percent	Percent	Percent	Percent	Percent	Percent	Percent	Percent	Percent			Percent	Percent	Percent	meq/100g	meq/100g	meq/100g	meq/100g	meq/100g	meq/100g	Percent	
0-5	IA ₁₁	0.2	1.0	1.5	2.7	2.0	57.0	35.6	33.4	26.9	1	7.7	5.8	2.53	0.240	10.5	32.5	16.8	5.2	0.9	0.1	0.5	70	
5-15	IA ₁₂	.4	1.5	2.2	4.3	3.2	52.1	36.3	32.1	25.6	1	4.5	5.6	1.81	.174	10.4	31.2	16.0	4.8	0.9	.1	.4	68	
15-19	IA _B	1.1	2.3	3.8	6.8	4.6	46.9	34.5	31.9	23.2	1	2.5	5.6	1.23	.128	9.6	27.5	14.8	4.6	7.6	.1	.4	72	
19-22	IB ₂₁	1.7	3.1	4.6	8.4	5.9	42.5	33.8	31.5	21.5	3	1.8	5.7	.97	.100	9.7	22.7	12.1	3.5	6.7	.1	.3	70	
22-24	IB ₂₂	1.9	4.1	5.4	10.3	8.1	37.4	32.8	31.3	19.9	35	1.2	5.8	.63	.074	8.5	22.4	12.6	3.8	5.6	.1	.3	75	
24-34	IB ₂₃	1.8	4.1	5.8	11.1	9.6	34.2	33.4	30.7	19.2	1	1.0	5.9	-----	-----	-----	21.6	13.0	4.3	2.9	.1	.4	87	
34-45	IB ₂₄	1.4	3.9	5.6	10.6	9.5	35.2	33.8	30.2	20.5	1	1.1	6.3	-----	-----	-----	20.1	12.7	3.1	4.0	.1	.3	80	
45-55	IB ₂₅	2.3	4.6	5.7	10.7	8.7	38.5	29.5	32.0	21.4	4	1.2	7.6	-----	-----	-----	calen	reous	-----	-----	-----	-----	-----	
55+	IC	3.3	5.8	7.2	13.5	9.9	38.2	22.1	35.2	20.3	6	1.0	7.7	-----	-----	-----	calen	reous	-----	-----	-----	-----	-----	

PROFILE O, CULTIVATED (PL. V: E.97, 3.7)

0-6	IA _{1P}	1.4	4.5	8.2	15.7	8.6	34.9	25.8	35.8	16.2	<1	0.9	5.4	1.77	0.166	10.7	22.1	10.0	2.8	8.9	<0.1	0.4	60
6-12	IA ₁₂	1.2	5.0	7.7	14.7	8.5	35.9	27.0	35.1	17.3	<1	1.0	5.4	1.41	.133	10.6	21.7	9.9	2.8	8.7	<0.1	.3	60
12-16	IA-B	1.6	5.1	7.1	13.2	8.3	36.7	28.0	34.0	18.1	1	1.0	5.3	.97	.096	10.1	20.3	10.3	2.8	6.9	<0.1	.3	66
16-21	IB ₂₁	2.4	5.3	7.2	13.4	9.1	35.0	27.0	33.8	18.1	3	1.0	5.4	.70	.072	9.7	18.7	10.5	2.8	5.1	<0.1	.3	73
21-23	IB ₂₂	3.7	5.8	7.4	14.3	10.0	35.4	25.4	34.2	17.1	23	.8	5.4	.51	.056	9.1	16.9	10.2	2.1	4.2	.1	.3	75
23-30	IB ₂₃	2.9	5.8	7.8	15.0	11.4	32.8	24.3	35.6	17.1	3	.8	5.6	-----	-----	-----	16.5	10.0	2.7	3.4	.1	.3	79
30-40	IB ₂₄	2.5	6.0	8.0	15.8	10.7	32.4	24.6	35.7	16.5	2	.8	5.8	-----	-----	-----	14.4	10.2	1.4	2.4	.1	.3	83
40-50	IB ₂₅	1.8	4.2	6.0	12.4	9.6	34.8	31.2	32.5	18.8	<1	1.0	6.3	-----	-----	-----	18.1	13.2	2.4	2.2	<0.1	.3	88
50-61	IC	2.1	4.8	6.0	12.4	9.2	37.6	27.9	33.0	20.9	4	1.0	7.6	-----	-----	-----	calen	reous	-----	-----	-----	-----	-----

TABLE 37.—Analysis of Olmitz silty clay loam (unit 53)

PROFILE P, CULTIVATED (PL. V: E.94, 3.6)

Depth (in-ches)	Horizon	Size class and particle diameter										Ratio silt/ sand	Org- anic car- bon	Nitro- gen	C/N	CaCO ₃ equiv- alent	Cat- ion- ex- change cap- acity (sum)	Extractable cations					Degree of base sat- uration		
		Very coarse sand (2-1 mm)	Coarse sand (1- 0.5 mm)	Med- ium sand (0.5- .25 mm)	Fine sand (0.25- .10 mm)	Very fine sand (0.10- .05 mm)	Silt (0.05- .002 mm)	Clay (<0.002 mm)	0.2- .02 mm	0.02- .002 mm	>2 mm							Ca	Mg	H	Na	K			
		Per- cent	Per- cent	Per- cent	Per- cent	Per- cent	Per- cent	Per- cent	Per- cent	Per- cent	Per- cent							Per- cent	Per- cent	Per- cent	Per- cent	Per- cent		Per- cent	Per- cent
0-6	IA ₁ P	1.2	4.7	7.8	13.9	7.0	40.7	24.7	36.6	18.4	<1	1.2	5.4	2.33	0.217	10.7	-----	22.7	9.6	2.9	9.1	0.1	1.0	60	
6-14	IA ₂	1.1	4.4	6.5	11.9	6.8	41.0	27.7	35.6	19.3	<1	1.4	5.4	2.00	.180	11.1	-----	23.5	10.6	2.9	9.6	<1	.4	59	
14-22	IA ₃	1.0	4.1	5.7	10.2	6.5	43.2	29.3	34.0	20.6	<1	1.6	5.5	1.67	.150	11.1	-----	24.3	11.3	3.6	9.1	<1	.3	63	
22-29	IA-B	.9	3.6	5.5	10.6	6.8	43.7	28.9	35.0	21.3	<1	1.6	5.5	1.27	.120	10.6	-----	21.2	11.6	3.0	6.2	.1	.3	71	
29-36	IB ₁	1.1	3.4	4.9	9.8	5.7	46.1	22.0	35.3	21.9	<1	1.8	5.8	.94	.097	9.7	-----	23.8	12.2	3.1	8.0	.1	.3	66	
36-46	IB ₂	1.1	3.1	4.5	9.6	6.6	45.2	29.9	35.2	21.9	<1	1.8	6.2	.74	.084	8.8	-----	21.5	13.2	3.3	4.5	.1	.4	79	
45-51	IB ₃	1.6	2.9	4.5	9.9	7.0	43.0	31.1	33.9	21.7	15	1.7	6.5	-----	-----	-----	-----	22.0	14.0	3.5	4.0	.1	.4	82	
51-62	IB ₄	1.8	3.7	5.0	10.6	7.7	51.2	20.0	31.5	33.4	2	1.8	6.6	-----	-----	-----	-----	20.7	14.4	3.8	2.0	.1	.4	90	
62-81	IC ₁	2.2	4.3	5.7	11.7	9.6	35.4	31.1	31.8	19.7	2	1.0	6.8	-----	-----	-----	<1	18.0	13.2	3.3	1.1	.1	.3	94	
81+	IC ₂	2.3	4.7	5.5	10.8	8.4	40.7	27.6	32.4	23.0	3	1.3	7.8	-----	-----	-----	11.8	calca- reous	-----	-----	-----	-----	-----	-----	-----

PROFILE Q, CULTIVATED (PL. V: F.97, 5.09)

0-7	A ₁ P	0.9	2.4	3.7	6.2	3.9	53.9	29.0	36.1	24.9	<1	3.2	6.2	2.47	0.222	11.1	-----	29.5	17.5	3.2	8.3	0.1	0.4	72
7-17	A ₁ P	.9	2.2	3.2	5.4	4.1	54.0	30.2	34.5	26.5	<1	3.4	5.8	2.14	.200	10.7	-----	27.6	15.4	3.2	8.5	.1	.4	69
17-27	A-B	1.0	3.0	4.3	7.3	4.6	50.2	29.6	36.0	22.8	<1	2.5	6.0	1.60	.152	10.5	-----	25.4	15.9	2.9	6.1	.1	.4	76
27-43	B ₂	2.8	3.6	5.0	9.5	6.3	43.9	28.9	35.3	20.1	<1	1.6	6.5	.71	.075	9.5	-----	22.4	15.8	3.0	3.2	.1	.3	86
43-54	B ₂	3.4	5.0	6.3	11.9	7.8	38.0	27.6	34.6	17.9	3	1.1	6.6	.37	.047	7.9	-----	22.4	15.2	3.2	3.6	.1	.3	84
54-59	B ₃	6.9	9.0	9.5	14.3	8.6	25.1	26.6	30.0	11.2	2.5	.5	7.0	-----	-----	-----	<1	21.5	14.7	2.8	3.6	.1	.3	83
59-78	D ₁	1.6	5.1	7.0	13.9	12.7	35.1	24.6	40.2	15.8	<1	.9	7.2	-----	-----	-----	<1	17.2	12.8	2.6	1.5	<1	.3	91

High silt/sand ratios (fig. 77) in these soils probably are related to loess in the source area. Low silt/sand ratios are related to a predominance of till in the source area. Generally higher silt/sand ratios of the Olmitz soils compared with the Arbor probably are the result of greater sorting of the alluvium as the distance from the source increases (fig. 76). The Olmitz occurs farther from the source than the Arbor. This general trend is reversed when the Arbor soils have source areas containing loess.

These soils have no definite horizon of clay accumulation (tables 36, 37). Some clay movement has taken place, however, because clay skins are on structural aggregates in the B₂ horizons of Arbor soils, especially in till. Well-oriented clay skins are on void walls in B horizons of an Olmitz soil.

Base saturation follows the same general pattern as other soils on valley slopes. Profiles O and P, however, have lower base saturation in the surface than other soils on valley slopes. Both formed in a position where the main source of material was the A₂ and B₂ horizon of the late Sangamon paleosol. Thus source of materials influences the base status of soils in alluvium.

Arbor and Olmitz soils are similar to the cumulative soils discussed by Nikiforoff (39, pp. 227-229). A problem in evaluating the genesis of these is determining the rate of accretion of the parent materials.

UNDIFFERENTIATED SOILS IN ALLUVIUM (UNIT 50)

Soils in unit 50 are in the alluvial fill of the South Turkey Creek valley and tributary and side streams (pl. V). These were not studied.

Discussion

Soils in the South Turkey Creek area formed in a variety of parent materials and, except for paleosols, under two geomorphic surfaces. The oldest soils on the modern landscape are of the Tazewell surface and have been weathering for about 14,000 years. Until 6,500 years ago soils of this surface may have had a coniferous and hardwood forest cover. The grass cover of the last 6,500 years may have been interrupted; this is indicated by abundant weed pollen at intervals in the McCulloch peat bog (31; 54, pp. 687-688).

We think the major period of erosion on the valley slopes is late Wisconsin-Recent because: (1) Slopes cross the sequence of older geomorphic surfaces — early Wisconsin, Tazewell, late Sangamon, and Yarmouth-Sangamon. (2) Slopes truncate the sequence of Pleistocene deposits and the regional weathering zonation in the loess. (3) Slopes can be traced under alluvial fills whose base is probably 6,800 years old. Therefore, soils on valley slopes probably are no older than 6,800 years and have formed under a climate favorable to grass.

Little information is available on the manner and time of erosion of valley slopes during the last 6,800 years. If the base of

the alluvial fill is 6,800 years old, then erosion on valley slopes must have taken place since that time because there is 10 to 15 feet of alluvium in valley-side waterways (fig. 31). But it is not known if erosion on valley slopes was gradual and continuous from 6,800 years ago to present, occurred in a series of cut-and-fill cycles separated by periods of stability, or occurred in one relatively short period followed by stability. If erosion on valley slopes was continuous during the last 6,800 years soils may have developed downward into parent material at a rate nearly equal to the rate of removal of material from A horizons. If the erosion was cyclic, soil formation would be periodically interrupted by truncation. Unless the entire solum was removed, B horizons or other parts of the former soil would be exposed at the surface and be transformed into A horizons by addition of organic matter and changes in structure. If the erosion cycle was completed in a relatively short time and was followed by a period of stability, soils may have formed in relatively fresh material and their properties are the result of one cycle of soil development. Thus, the history of soils on the late Wisconsin-Recent surface may be very complex.

The general morphology of soils in loess, till, and valley-side alluvium is similar, but there are differences in colors and thickness of horizons. Laboratory data show differences in depth of leaching, organic matter accumulation, and clay distribution.

Leaching in the loess-derived soils, as indicated by depth to 75-percent base saturation, is greatest in unit 12 soils of the Tazewell surface and least in the younger unit 11 soils of the late Wisconsin-Recent surface. Unit 13 is more deeply leached than associated unit 11, probably because it is in a somewhat wetter site. Base saturation in A and B horizons of soils in Kansan till, in general, is less where depth to carbonate is greater (fig. 75). Differences in carbonate content of parent materials probably is responsible. Base status of the source of the alluvium, original carbonate content of the till, and differences in moisture regime at each profile site probably are responsible for the variation in base-saturation values of Arbor and Olmitz soils.

Organic-carbon distribution of loess-derived soils follows the same general pattern in all these soils. But it does drop to lower percentages at shallower depths in unit 11 soils, especially those with the clay maxima closest to the surface. Organic-carbon distribution in till-derived soils follows the same pattern as the loess-derived soils. Greater carbon content in the surface of Arbor and Olmitz soils than in associated soils in till or loess probably is a result of the wetter sites and addition of carbon in the alluvium.

Clay distribution should reflect some of the dominant effects of soil-forming factors because it is a more stable characteristic than soil properties such as organic carbon or percent base saturation. Loess was a uniform parent material so present clay distribution should be related to the environment in which the soils formed.

Clay distribution patterns of loess-derived soils are in three

groups: In unit 12 soils, clay content increases from the surface to about 9 inches, then is the same to about 19 inches where a second increase begins that reaches the maximum at about 25 inches. From this maximum there is a steady or regular decrease for about 16 inches. Unit 11 soils of the Tazewell surface do not show the stepwise increase and depth to clay maximum is less—18 inches in profile E and 12 inches in profile D. In loess soils of the late Wisconsin-Recent surface, the clay maximum is within the upper 9 inches. The amount of clay in the clay maximum in all profiles is about 38 percent and the shape and slope of the lower or return part of the distribution curve is similar in all of them.

Thin-section data on loess-derived soils are incomplete, but in unit 11 profile G the horizon with the maximum clay—the AB horizon—had the largest amount of old, distorted former clay skins and only a few clay skins on ped faces. The faces in the B₂ horizon were coated with thin clay skins and the horizon had distinct, well-oriented clay skins in most of the voids; but ped interiors had few of the relict clay bodies and are still like the C horizon.

The till is less uniform than the loess. But clay distribution in till soils is similar to that in unit 11 and 13 soils in loess. This applies to the amount of clay in the clay maximum and to the range of position of the clay maximum. Presence of clay skins in and below the clay maximum indicates that clay illuviation has been active. Since depth and size of the clay bulge in Shelby and related soils appears to be controlled by lime content and texture of till, it is difficult to assess the effect of age, topography, or erosion on characteristics of the soil. Thin sections of AB horizons in profiles K and L showed that ped faces are stripped of clay, but interiors of the peds contain much segregated oriented clay, suggesting that the AB horizon is a former B horizon that is now being degraded.

Clay distribution with depth in Arbor and Olmitz soils is irregular and probably more closely related to texture of the alluvium and the underlying till than to clay illuviation. Thin sections from the Arbor soils indicate, however, that some clay movement into B horizons has taken place, especially into till. Olmitz soils have common, well-oriented clay skins on void walls in the B horizon. There is little evidence of illuviation in the A horizon. The loess- and till-derived soils have distinct clay maxima and illuvial clay in surface horizons but Arbor and Olmitz soils do not have these features. All these soils occur on the same slope units and have similar age, vegetation, and geomorphic history. The differences in clay distribution and placement of illuvial clay horizons may be the result of truncation of the upslope Shelby and Sharpsburg soils and deposition on Arbor and Olmitz soils. Another possible interpretation is that alluvium in the Arbor and Olmitz soils had a smaller amount of readily dispersible, easily moved clay than the associated soils because this clay had been washed out when the material was moved from its original position.

Several possible factors of the environment and events in the history of soils and landscapes could explain the observed differences. The differences may be the effect of a combination of a number of factors. The soils were in a small area in nearly homogeneous parent materials and their characteristics can be compared. Comparisons or hypotheses made on the basis of this small group of soils may not apply to other soils in other parts of the region.

A clay maximum or "clay bulge" can form as a result of weathering or illuviation or a combination of these two processes. Petrographic examination and consideration of the cation-exchange capacities show that part of the clay increase may be only apparent. In these soils organic matter does not appear to increase exchange capacity. Cation-exchange capacities do not increase from C horizons to B horizons as much as the clay itself increases. Where there is an increase it is often only roughly related to the position of the clay maximum. The composition of the clay fraction is the same throughout loess-derived soils; montmorillonite is dominant and there are small amounts of mica and kaolin. There is no known difference in mineralogy between B and C horizons. Thus, one might conclude that the clay increase in the B horizon is produced by weathering of clay minerals or aggregates of silt size, but not by weathering of primary minerals, such as feldspars, in silt. Microscope examination of grains and thin sections from C horizons suggests sources of such clay. Various types of aggregates, such as iron- and silica-cemented grains, shale chips, partly-weathered minerals, especially biotite, and quartz and feldspar particles with clay adhering in rough spots, could resist dispersion but gradually break down under the influence of the soil-forming processes. Clay as a size fraction is thus formed by weathering. Some clay is also added by actual weathering of primary minerals in soil but the fresh condition of weatherable minerals in similar soils (author's observations, Marshall and Dow series) suggests that this may be only a small part of the total clay increase. Biotite may yield clay and some of the easily-weathered ferromagnesian minerals can decompose to liberate the ingredients of montmorillonite.

If weathering alone were responsible for the clay increase one might expect to find the clay maximum in the surface or near the surface where the processes would be most intense. Such a clay distribution is found in till and loess soils of the late Wisconsin-Recent surface and is not uncommon in other Iowa soils. Production of clay by weathering combined with, or followed by, clay destruction could produce a soil with a low clay content in the surface horizon and a clay maximum below. The broadening and lowered intensity of montmorillonite reflections in X-ray patterns of these and similar soils indicates that clay destruction may be a factor in removal of clay from the upper horizons.

In all profiles in loess there is a slight increase in fine silt above a depth of about 30 inches. In some soils (unit 12) the fine silt

maximum coincides with the clay maximum; in others it is below the clay maximum. A particle size change of this kind could be the result of weathering, though other interpretations are equally valid. A decrease in fine silt probably is the result of chemical weathering; but physical weathering, especially breaking up of aggregate grains, could cause an increase.

Clay increases produced by weathering would be expected to be greater in older soils in stable landscape positions than in younger soils, and greater where agents of weathering are strongest as, for example, in moist sites. In the group of soils considered in this study, however, the clay maximum is the same in all soils but has a depth range from 6 to 24 inches. This poses some interesting problems for any explanation of profile development. It may be a coincidence and have no meaning, or it may be the wrong value and one should examine depth-volume relationships instead of weight percentages of clay.

Weathering, thus, makes a contribution to increase in clay in the upper solum but field and laboratory studies show that illuviation has also been important in clay distribution in these soils. Clay skins are seen on ped faces in the field in B horizons; in deeper horizons they are in channels and tubular voids. The thin-section observations show that illuviation has been active in the study area. Clay skins are on ped faces in B horizons in unit 11 profile G, unit 21, unit 23, and in Arbor and Olmitz soils. Very thin, interrupted or patchy clay skins are on faces in A or AB horizons of the same profiles. The only C horizon section available was from profile G and it contained prominent, well oriented clay skins in most of the voids. Voids are mostly tubular pores.

Amount and arrangement of clay in ped interiors is also indicative of past illuviation. Stringers and patches of segregated, oriented clay several times larger than any of the grains are relics of former clay-coated ped faces and collapsed clay-lined voids. Some of these are parallel to present faces and some intersect existing void walls. Pressures have caused distortion, and some of these bodies of clay are less evident than others. Some of this relict, moved clay may have been completely reincorporated into the matrix. This type of clay body has been observed in Gray-Brown Podzolic soils and other soils in which shrinkage and swelling takes place.

This relict, moved clay is abundant in the B horizon of the Olmitz sample, in unit 21, and in the upper B horizon of unit 23. It is abundant in A horizons of units 21 and 23 but scarce in the A horizon of the Olmitz. Profile G unit 11 of the late Wisconsin-Recent geomorphic surface, contains an abundance of such clay bodies at the 5- to 8-inch depth, fewer in the 10- to 13-inch sample, and very few in the C₁ horizon. In the C₁ horizon of this profile most of the clay is in silt-size flakes and irregular aggregates and grain coats. There is some pressure orientation but few bodies of clay larger than the primary grains. In the B₂ horizon ped interiors resemble the C₁ horizon but exteriors are coated with clay and clay also impregnates the walls of peds. Local patches of this

horizon contain concentrations of clay segregations in ped interiors. The AB horizon has large areas of illuvial clay in bodies larger than the grains that are not associated with present surfaces. Micromorphological observations indicate that illuvial clay is present in the AB horizon of profile G. This conclusion we base on comparison with other soils in the study area and on our observations on other soils where clay illuviation is well established. Shelby and Shelby-Steinauer A and AB horizons contain more of this type of clay than profile G and Olmitz much less.

Distribution of clay can be accounted for by a summation of processes. A large part of the clay was already present in the original parent material. Weathering (including wetting and drying, freezing and thawing, chemical reactions, and biological activity) breaks up the clay into smaller particles, causes disintegration of aggregates, such as partly-weathered grains, and causes the formation of additional clay particularly from micas, ferromagnesian minerals, and calcic plagioclase. Clay is made movable by these same processes, especially as a result of the formation of organic-matter-montmorillonite complexes and the removal of cemented agents such as iron oxides. Weathering thus increases the total clay content of the solum and the increase would be greatest where the weathering processes are most intense.

Some clay is probably immediately movable and other forms become movable more slowly. Hence the rate of a process of textural profile development by illuviation might be expected to be rapid at first then become slower as the supply of movable clay made available by weathering dwindled. Ultimately the supply of "free" or "parent material" clay would become exhausted and further clay accumulation would depend upon weathering of primary minerals, a much slower process. In a mild weathering environment the process might slow down at an early stage. A rigorous physical and chemical weathering environment would hasten the disintegration of clay aggregates and also bring about alteration of primary minerals in a shorter time.

Movement and accumulation of clay is affected by climate and texture of solum material as well as by processes that render clay dispersible. When a dry soil is wetted, some clay on surfaces of aggregates slakes and is brought into suspension. Water carrying this clay, moving down pores and cracks and between ped faces, is sucked into dry aggregates and clay is filtered out on aggregate surfaces or void walls. Clay in suspension can move in any direction and as far as the water itself; some clay coats may be the result of local lateral or upward water movement. Movement of clay may go on in a stepwise fashion or in successive waves; but it should reach an equilibrium position related to depth of wetting after drying, depth of root systems of prevailing plants, and presence of interfering layers such as calcareous horizons or texture breaks. Evidence of clay illuviation such as clay maxima and clay skins may reflect past climates as well as the present one.

Factors Influencing Soil Formation

Many factors resulting from the geomorphic history of landscapes, past and present climate and vegetation, and present position of soils on the landscape have affected soil profile characteristics.

AGE

Level divides and interfluvial summits where the areas of Sharpsburg unit 12 are located have not been eroded and have been stable since the end of loess deposition—the end of Tazewell time. The higher gently sloping areas of unit 11 such as the sites of profiles D and E are also of this Tazewell surface. The soils of this surface have been developing for 14,000 years.

But soils on the valley slopes may be less than 6,800 years old and have had about half as long to develop as soils of the Tazewell surface. If the rate of soil formation was constant throughout this time, the oldest profiles should have thicker and possibly deeper horizons of clay accumulation and lower base status at a given depth from the surface. Organic matter, however, may accumulate rapidly and its distribution and amount may not reflect much of the previous history of a soil or large portion of the time of soil formation.

VEGETATION

Recent work (53, 54) has shown that the Tazewell surface probably was forested at least during the early part of the time of formation of Sharpsburg soils. Pollen analyses by Lane (31, p. 167) and radiocarbon dating by Ruhe, Rubin, and Scholtes (54) suggest that grass has been the dominant vegetation in the 6,800 years that is the maximum time for soils of the late Wisconsin-Recent surface.

Smith, Allaway, and Riecken (65) suggested that the gray silt coats on the structural aggregates of the Tama silt loam, (a Brunizem) were a relict feature of a former Gray-Brown Podzolic soil. Shrader (58, p. 336) found that the clay content of surface horizons of Gray-Brown Podzolic soils was much lower than that of associated Brunizems derived from similar parent materials. Greenfield quadrangle soils do not have silt coats nor markedly low surface-horizon clay content. Specific morphological characteristics that can be attributed directly to the influence of forest vegetation are absent. Either the forest had a short-term influence or its effects have been destroyed or obscured by the later effects of grass and possibly soil fauna. Past forest vegetation is a possible cause for the location and shapes of the clay maxima of the Tazewell-surface soils, however.

SLOPE GRADIENT

Slope angle and position of the soil on the slope affect moisture regime and erosion. On flat uplands most of the water goes into the soil. On straight or convex slopes there is runoff and less infiltration. Soils on concave slopes, especially lower slopes, might

receive surplus water as runoff from above or even seepage. This difference in moisture amount and penetration has an effect on depth and shape of clay distribution maxima and depth of leaching as indicated by depletion of calcium and magnesium. It may also have an effect on organic-matter distribution since greater retention of moisture might be expected to favor growth of grass on flat uplands and on soils in concave positions such as unit 13.

Erosion is another factor that is controlled by gradient, length and form of slope, and vegetation density. Under grass, slopes in the units studied are now stable and little erosion is taking place. In other climates, and especially during period of sparse vegetation, erosion probably did occur. It was zero or minor on the Tazewell surface but probably appreciable in the areas of late Wisconsin-Recent surface where profiles C and G were collected. Profile F is in a site where accumulation could occur. There is a possibility that small amounts of clay carried in suspension from upper parts of the slopes could have contributed to the supply of illuvial clay in soils in lower positions.

History of the Soils

In soils of the Tazewell surface the factors discussed—age, past and present climate and vegetation, and slope and its effect on moisture infiltration and erosion would all tend to cause the formation of deeply leached soils with deep clay maxima. Unit 12 has had a forest vegetation and a moister climate than at present and is in a position to lose little water by runoff. The gently sloping Tazewell surface areas of unit 11 (profiles D and E) are the same age and have had the same environmental history but because of their slope and position erosion may occur. This and the difference in moisture infiltration offers an explanation for the differences in leaching and depth to clay maxima between unit 12 and this part of unit 11.

The soils of the late Wisconsin-Recent surface, however, have had a maximum of 6,800 years to form. During this time the climatic conditions favored grass and there may have been periods that were drier than present. The steeper slopes affected moisture movement and supply, depending on position and configuration of the slopes. All of the historical and environmental factors would favor the development of a soil with a clay maximum high in the solum. With starting material of the same texture and composition, however, shorter time, drier climate, and less infiltration might be expected to cause a soil to develop a small as well as shallow clay maximum. The presence of old, distorted clay skins in ped interiors and few clay skins on ped exteriors suggest that AB horizons of many soils are former B horizons that are now being degraded. This interpretation assumes that soil peds are relatively permanent, an assumption that may have little validity under changing climatic and moisture regimes; but parts of peds, at least, should survive. If the interpretation that AB horizons of loess and till soils are former B horizons is correct, truncation of these soils seems plausible. Supporting evidence

is the accumulation of exactly the same percentage of clay in clay maxima in all loess-derived soils with a variety of depth of material above the maximum. But this involves postulation of formation of a profile much like unit 12 in half the time, on a steeper slope, and with a different environmental history. It also involves removal of a very uniform amount of material over a large area. The occurrence of soils with a shallow clay maximum is too widely observed for truncation to be the only explanation for this morphology, though it may have occurred in some of them.

It is also possible that loess-derived soils on valley slopes formed an illuvial clay maximum high in the profile under a drier climate. But a smaller clay maximum would be expected under these conditions. Possibly the amount of easily moved clay was the same at all sites and weathering under either geomorphic surface has not been intensive enough to produce more easily moved clay than was originally available in the parent material.

The Tazewell surface is twice as old as the late Wisconsin-Recent surface. By the time the major valley-slope erosion period started 6,800 years ago, the rate of clay release and movement in unit 12 soils may have slowed to where there was only a small supply of readily movable clay in the upper 2 feet. The step in the distribution curve of the unit 12 profile may indicate a change in weathering conditions that is now releasing a new wave or increment of clay. The occurrence of soils possibly truncated within the past 6,800 years that have the same clay maximum as those of the stable surface suggests a time limit for the attainment of release-movement equilibrium.

Implications of causes for differences in the shape of clay distribution curves in these soils and others are important in geomorphology and soil science. Further work involving direct observations on soils is needed to determine whether different processes produce similar clay maxima in different parts of the solum.

Chapter 4

Soil Landscapes in the Thick Loess of Central Pottawattamie County, Iowa

by Raymond B. Daniels, *soil scientist, Soil Conservation Service*

Introduction

To determine the relation between a landscape, its evolution, and soil genesis in the Marshall soil association area, a small watershed in the south half, sec. 13, T. 76 N., R. 41 W., Pottawattamie County, Iowa, was studied (fig. 76). Stratigraphic and geomorphic control could be established because Tazewell loess was exposed in a railroad cut at the south end of the area and the alluvial fill had been dated (43, W-235).

Topography of the watershed is typical of the western part of the Marshall soil association area. Divides are narrow and gently convex to level but are broken at irregular intervals by topographic saddles. Valley slopes are long and relatively smooth and have gradients of 6 to 12 percent.

The watershed is in the Marshall soil association area but soils on valley slopes are of the Monona-Ida-Hamburg soil association.

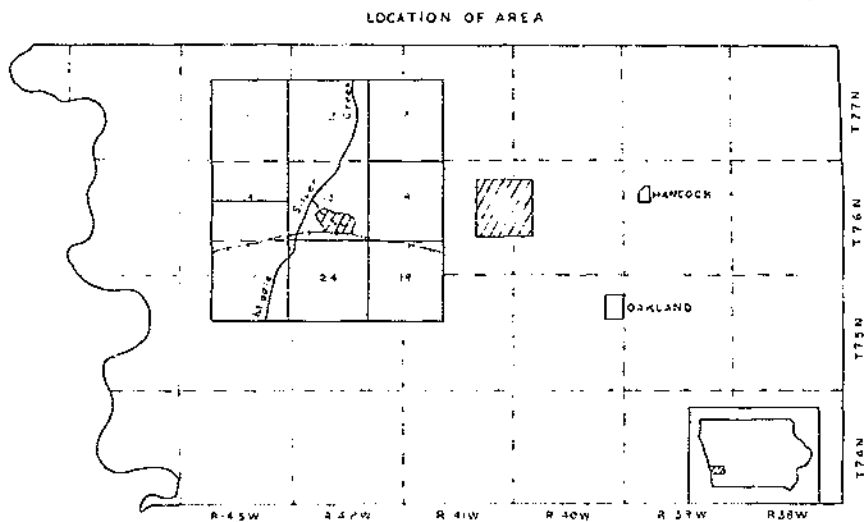

FIGURE 78.—Location of study area in Pottawattamie County, Iowa.

Deoxidized and
leached
343-419 inches

Grayish brown (2.5Y 5:2) silt loam; few to many yellowish red and dark reddish brown (5YR 4:8 and 3/4) pipestems; massive; friable; leached; sharp boundary.

Farmdale loess:

A_b
419-429 inches

Very dark grayish brown (10YR 3/2) to dark grayish brown (10YR 4/2) silt loam; weak fine granular structure; friable; leached.

C₁
429-449 inches

Brown (10YR 5/3) silt loam; massive; friable; leached; clear boundary.

The contacts between the weathering zones in cut 39 parallel the top of the Loveland loess. Near gully fills the deoxidized and unleached zone slopes downward and joins the lower deoxidized and leached zone (fig. 79). East of the eastern gully fill the entire cut is gray and the two deoxidized zones could not be separated because the lower deoxidized zone has been recharged with carbonate.

The oxidized and leached zone is under the level to gently convex divides and upper parts of the valley slopes. It thins and is truncated by the present slope (fig. 80). The other weathering zones slope from the center of the divide to their outcrop on the valley sides (pl. VI).

Ruhe and Scholtes (53, p. 272) found that between Atlantic and Bentley, Iowa, the upper deoxidized zone was independent of stratigraphic zonation of the loess. They decided the zone must be of later Wisconsin age. Ruhe, Prill, and Riecken (52, p. 345) believed that the deoxidized zones are relict features of a preexisting water table and zone of saturation. They suggested that a general condition of poorer drainage or two paleoclimatic periods of greater precipitation, or both, may have produced the deoxidized loess zones. Ruhe and Scholtes thought that the deoxidized zones must represent a postloess climatic regime that permitted a zone of permanent water saturation to occur in the present position of the upper deoxidized zone. Though the evidence indicated that the cause of the weathering zonation of the Tazewell loess was a former water table and zone of saturation, there are now no permanent zones of saturation in the upper deoxidized zone.

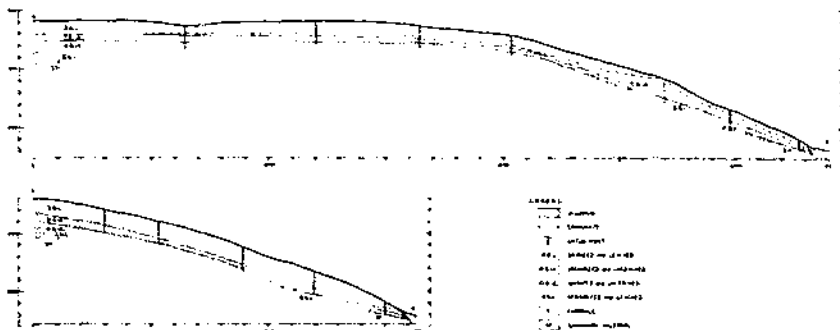

FIGURE 80.—Distribution of weathering zones in the Tazewell loess along the axes of divides.

The absence of massive gray horizons and pipestems in the oxidized and leached zone indicate that this zone has not been water saturated for long periods; gray mottles, however, indicate impeded drainage during the formation of the upper deoxidized zone. Pipestems that can be traced from the upper deoxidized zone into the underlying loess zones or sediments suggests that the upper deoxidized zone has had intensive reducing conditions. The lower oxidized and unleached zone, while similar in color to the upper oxidized and leached zone, probably was water saturated during the development of the zone above. Less intensive iron reduction in this zone than in the deoxidized zone is indicated by the yellowish brown matrix colors and the absence of massive gray areas. But few pipestems and many gray mottles suggest that some iron movement and segregation took place.

The free iron content of the bulk samples of the deoxidized zone is similar to that of the oxidized unleached zone (table 40). Most of the free iron of the deoxidized zones probably is in pipestems whereas the free iron of the oxidized and leached zone is dispersed throughout the matrix. Thus, past weathering apparently has influenced not only the amount of free iron of each loess zone but also its distribution.

TABLE 40.—Total and free iron of selected samples from cut 39

Kind of sample	Sample No.	Loess zone	Total iron ¹	Free iron ²
			<i>Percent</i>	<i>Percent</i>
Oxidized loess, bulk samples	1	O & L	3.1	0.7
	2	O & UL	2.5	.4
Deoxidized loess, bulk samples	3	D & UL	2.2	.4
	4	D & L	-----	.1
	5	D & L	-----	.4
Deoxidized loess, gray matrix	6	D & UL	1.9	.0
Pipestems	7	D & UL	11.4	2.6
	8	O & UL	6.7	2.2
	9	O & UL	-----	1.8

¹ Total iron was determined by fusing 0.5 g. oven-dry samples with sodium carbonate according to standard procedure (3). The iron in solution was determined colorimetrically by the O-phenanthroline method (66, p. 314).

² The free iron of 1-g. samples was extracted by Jeffries' method (23). The iron in solution was determined colorimetrically by the O-phenanthroline method.

³ Sample 1 was from the C₁ horizon of profile P-600.

⁴ Expressed as percent Fe.

⁵ Sample 9 was collected from the B₂ horizon of profile P-603.

Alluvium 18 to 20 feet thick (fig. 81) covers about one-third of the watershed (pl. VI: index map). It covers flat to slightly concave lower parts of the valley slopes, spoon-shaped areas at the head of waterways, and areas in and near waterways and streams. It is a very dark grayish brown or dark brown (10YR 3/2 or 4/3) silty clay loam. A sample from the lower part of the alluvium exposed in cut 39 has a radiocarbon age of 6,800 ± 300 years (43, W-235).

GULLY FILL CROSS SECTIONS

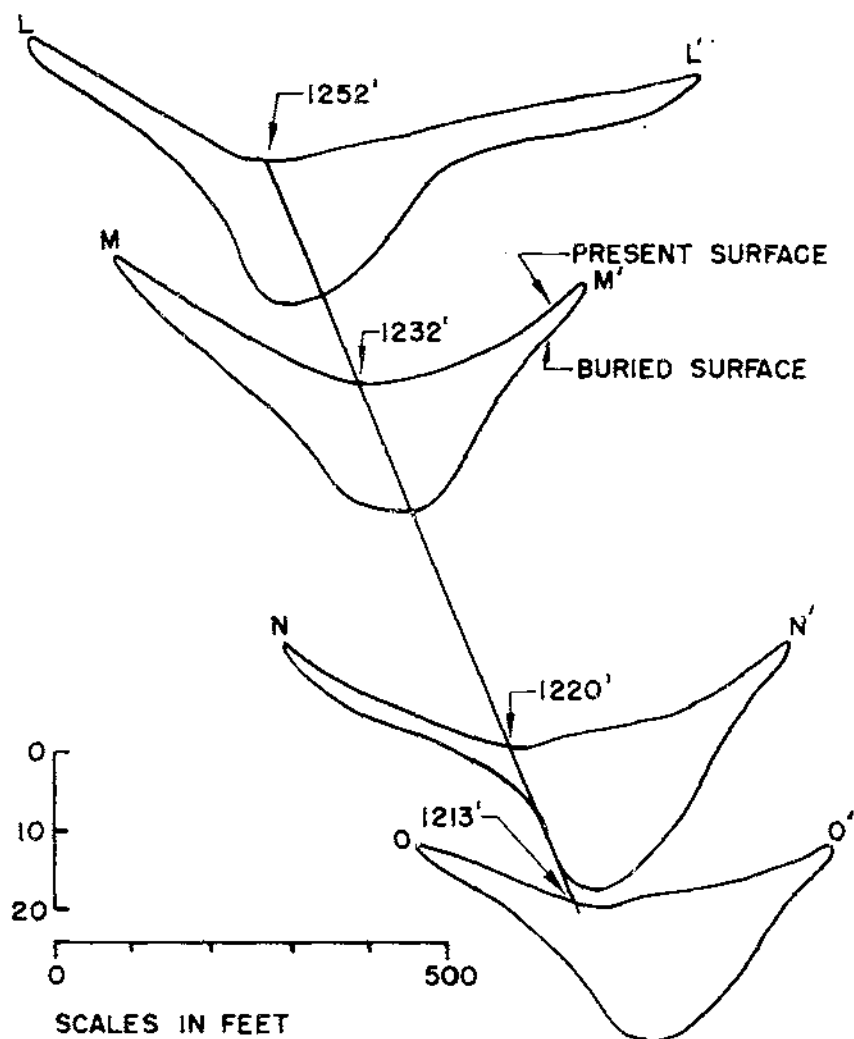

FIGURE 81.—Cross sections of the alluvial fill.

Geomorphic Surfaces

As discussed in chapter 1, the upper part of the Wisconsin loess in the watershed is Tazewell in age and younger than 17,000 but older than 14,000 years. The top of the loess on divides that have not been eroded is the Tazewell surface (fig. 82). Stability of the Tazewell surface is indicated by the following: (1) The surface parallels but does not truncate the weathering zonation of the Wisconsin loess (figs. 79, 80); if it truncated the zonation, it

would be later than the zonation. (2) The complete sequence of weathering zones is under all level to gently convex divides and ridges between Bentley and Atlantic, Iowa (ch. 1). (3) The slopes of the divides and ridgetops are 0 to 2 percent and erosion should be slight.

The Recent surface is on the valley slopes, the sharply convex ridgetops, and the top of the alluvial fill (fig. 82). The valley slopes and the alluvial fill are younger than the Tazewell uplands

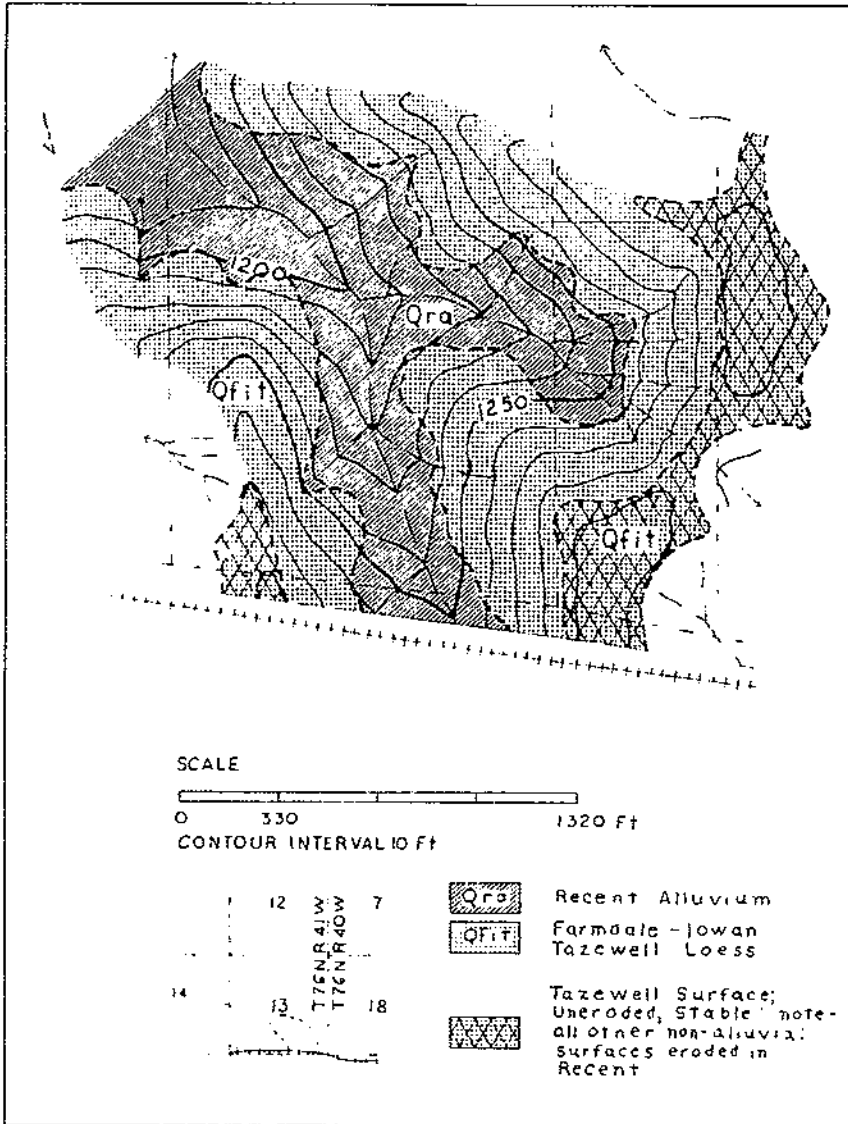

FIGURE 82.—Distribution of the Tazewell and Recent surfaces.

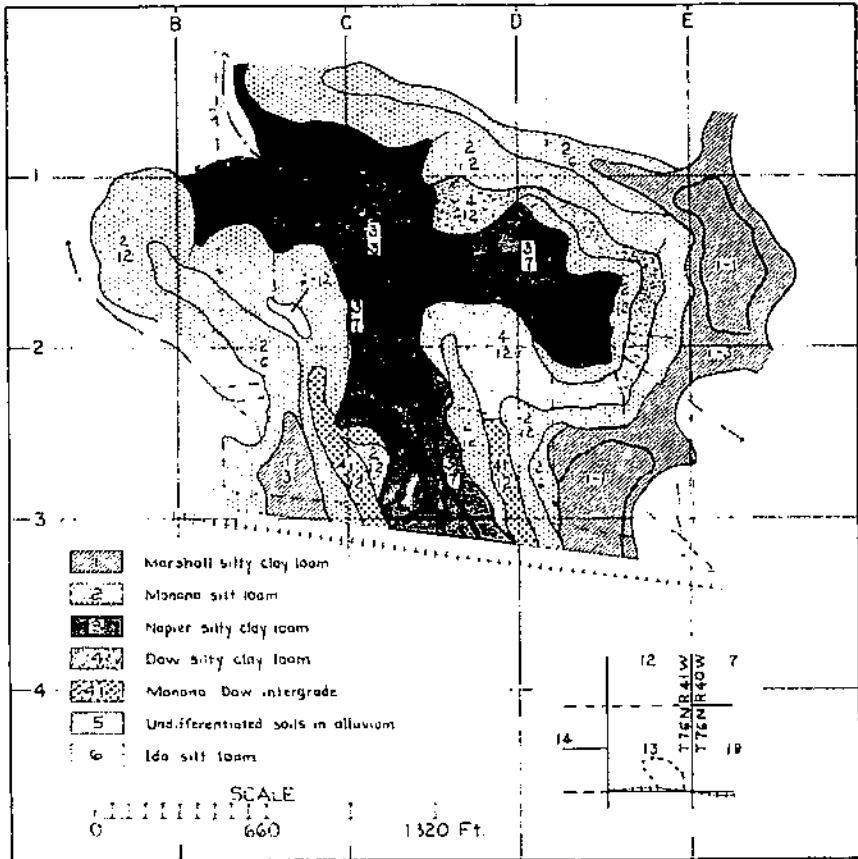

FIGURE 83.—Distribution of soils in the vicinity of cut 39.

because: (1) The present valley slopes truncate one or more of the weathering zones of the Tazewell loess. The weathering zones have been dated as late Wisconsin (53, p. 272) and the valley slopes must be later than the loess zones. (2) The valley slopes can be traced under the alluvial fill whose lower part is known to be $6,800 \pm 300$ radiocarbon years and 16 feet of sediment overlies the site of the radiocarbon sample. Thus, the age of the upper part of the fill must be less than $6,800 \pm 300$ years. (3) The alluvial fill is continuous from the mouth to the head of the drainage system and overlies the lower deoxidized zone and part of the lower oxidized and unleached zone (pl. VI: D-D', G-G', J-J', and K-D'). Therefore, the sediment of the fill must have been derived from the adjacent valley slopes and the valley slopes are less than $6,800 \pm 300$ years old.

I do not imply, however, that the Recent surface has the same age throughout its distribution. Areas of the surface may have stabilized shortly after 6,800 years ago whereas others continued to erode or have had alluvium deposited until the present time.

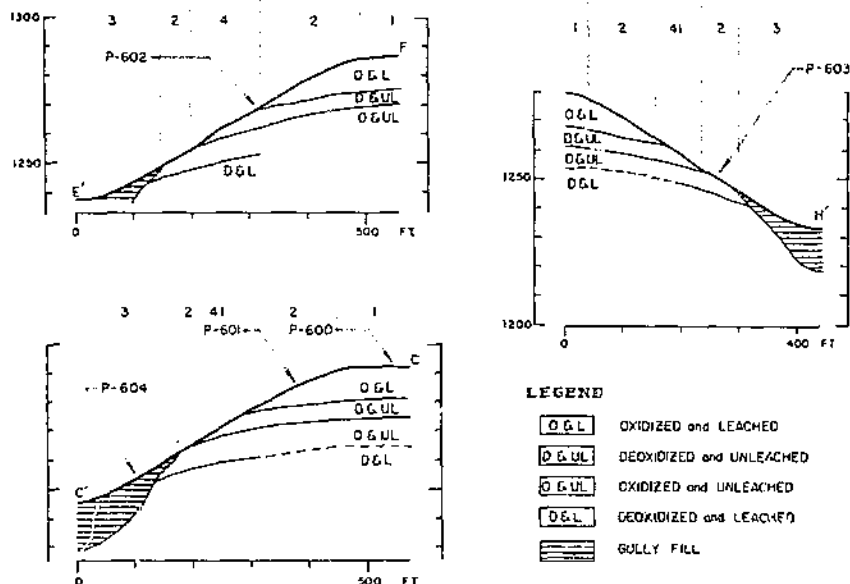

FIGURE 84.—Location of soils sampled with reference to the zonation of the Tazewell loess. P-603 and P-601 are Monona soils P-602 is a Dow soil; and P-600 a Marshall. Numbers 1, 2, 3, 4, and 41 refer to soil mapping units (table 39).

Soils

The geomorphology of the watershed shows that soils of the Tazewell surface have weathered for less than 17,000 but more than 14,000 years. Soils of the Recent surface, by contrast, have weathered for less than 6,800 years. Also, soils of the Recent surface formed in leached and calcareous loess and in oxidized and deoxidized loess. Thus, when the properties of the soils in the watershed are compared and contrasted the age and parent material differences must be considered.

Morphology

Marshall soils of the Tazewell surface and the upper edge of the Recent surface are on slopes of 0 to 4 percent (figs. 82, 83). The morphology of a Marshall soil on a gently convex divide in the oxidized and leached zone (figs. 83: D.4, 3.08¹⁶; 84, P-600) is:

P-600: slope, 1 percent, convex; cultivated field.

A₁₁ Very dark brown (10YR 2/2) light silty clay loam; cloddy but breaks to weak fine granular structure; friable; oxidized and leached Tazewell loess; abrupt boundary.

¹⁶ Grid coordinates on figure 83 are designated in the following manner: D.4 is located 4/10 of the distance between gridlines D and E. 3.08 is located 8/100 of the distance between gridlines 3 and 4.

AB 6-10 inches	Very dark brown (10YR 2/2) light silty clay loam with mixing of very dark grayish brown (10YR 3/2); weak fine granular structure; friable; gradual boundary.
B ₂₁ 10-16 inches	Very dark grayish brown (10YR 3/2) light silty clay loam; weak fine subangular blocky structure; friable; gradual boundary.
B ₂₂ 16-25 inches	Dark brown (10YR 3/3) light silty clay loam; weak fine subangular blocky structure; when dry peds arranged in weak coarse prisms; friable; gradual boundary.
B ₃ 25-35 inches	Dark yellowish brown (10YR 4/4) heavy silt loam; few fine gray and brown mottles; weak medium blocky structure; friable; gradual boundary.
BC 35-45 inches	Dark yellowish brown to (10YR 4/4) heavy silt loam; few fine grayish brown (2.5Y 5/2) and strong brown mottles; weak medium blocky structure; friable; gradual to diffuse boundary.
C ₁ 45-120 inches	Yellowish brown (10YR 5/4) medium silt loam; common fine and medium grayish brown (2.5Y 5/2) and light brownish gray (2.5Y 6/2) and few fine strong brown mottles; grayish brown and light brownish gray mottles increase in number with depth; massive; friable.

This Marshall soil has characteristics common to most Brunizems (65, p. 159) and is comparable to the Marshall soil studied by Hutton (21, 22). The very dark brown A horizon grades downward to a dark brown B horizon. The B horizon is not strongly developed texturally or structurally and has a gradual or diffuse boundary to the underlying C horizon.

Monona soils of the Recent surface are in the oxidized and leached and oxidized and unleached zones on slopes of 6 to 12 percent. Soils in both zones have similar morphologies but differ in carbonate content of the C horizons.

The morphology of a Monona soil in the oxidized and leached zone (figs. 83: D.18, 3.02; 84, P-601) is:

P-601: slope, 10 percent, convex; cultivated field.

A _{1P} 0-6 inches	Very dark brown (10YR 2/2) light silty clay loam to heavy silt loam; weak fine granular structure; friable; leached oxidized Tazewell loess; clear boundary.
AB 6-9 inches	Very dark grayish brown (10YR 3/2) light silty clay loam; weak fine subangular blocky structure; friable; gradual boundary.
B ₂₁ 9-15 inches	Dark brown (10YR 3/3) light silty clay loam to heavy silt loam; weak fine subangular blocky structure; friable; gradual boundary.
B ₂₂ 15-21 inches	Dark brown (10YR 4/3) heavy silt loam; weak fine subangular blocky structure; friable; gradual boundary.
B ₃ 21-33 inches	Dark brown (10YR 4/3) heavy silt loam; common fine grayish brown (2.5Y 5/2) and few fine strong brown mottles; weak medium blocky structure; friable; gradual to diffuse boundary.
BC 33-41 inches	Dark yellowish brown (10YR 4/4) heavy silt loam; common medium grayish brown (2.5Y 5/2) and few fine strong brown mottles and dark oxides; very weak medium to coarse blocky structure; friable; diffuse boundary.
C ₁ 41-68 inches	Yellowish brown (10YR 5/4) medium silt loam; common fine and medium grayish brown (2.5Y 5/2) and few fine strong brown mottles; few fine dark oxides; massive; leached; base of the oxidized and leached zone; clear boundary.
C ₂ 68+ inches	Grayish brown (2.5Y 5/2) medium silt loam; few fine to medium strong brown (7.5YR 5/8) mottles; massive; calcareous. The C ₂ horizon is the upper deoxidized and unleached zone.

The morphology of a Monona soil (figs. 83: C.15, 2.67; 84, P-603) in the oxidized and unleached zone is:

P-603: slope, 12 percent, convex; cultivated field.

A₁₀ 0-5 inches	Very dark brown (10YR 2/2) heavy silt loam to light silty clay loam; weak fine granular structure; friable; leached Tazewell loess; abrupt boundary.
AB 5-8 inches	Very dark grayish brown (10YR 3/2) heavy silt loam with mixing of dark brown; weak fine subangular blocky structure; friable; gradual boundary.
B 8-14 inches	Dark grayish brown (10YR 4/2) heavy silt loam; weak fine subangular blocky structure; gradual boundary.
B₂₂ 14-23 inches	Dark brown (10YR 4/3) heavy silt loam; few yellowish red pipestems less than $\frac{1}{8}$ inch in diameter; weak fine to medium subangular blocky structure; friable; gradual boundary.
B₃ 23-34 inches	Dark yellowish brown (10YR 4/4) heavy silt loam; few fine grayish brown (2.5Y 5/2) mottles and few yellowish red (5YR 4/6) pipestems; weak medium blocky structure; friable; abrupt boundary.
C₁₁ 34-35 inches	Dark yellowish brown (10YR 4/4) friable silt loam; few fine grayish brown (2.5Y 5/2) mottles; many carbonate concretions $\frac{1}{2}$ to 1 inch in diameter; matrix leached.
C₁₂ 35-52 inches	Dark yellowish brown (10YR 4/4) medium silt loam; common fine grayish brown (2.5Y 5/2) mottles and many yellowish red (5YR 4/6) pipestems; massive; friable; leached, but a few carbonate concretions. The matrix is leached, but in deep borings along the axis and transverse to the ridges the matrix of this loess zone was calcareous. Base of the oxidized and unleached zone; abrupt boundary.
C₁₃ 52+ inches	Grayish brown (2.5Y 5/2) medium silt loam; common strong brown and yellowish red (7.5YR 5/6 and 5YR 4/6) pipestems with a maximum diameter of $\frac{1}{4}$ inch; massive; friable; leached. The C ₁₃ horizon is the basal deoxidized and leached zone.

Dow soils, unit 4, are in the deoxidized zones on slopes of 9 to 12 percent. A horizons are very dark grayish brown (2.5Y 3/2) to very dark brown (10YR 2/2) and 0 to 6 inches thick. The B and C horizons are grayish brown (2.5Y 5/2); C horizons are calcareous in the unleached zone but noncalcareous in the lower leached zone.

From their morphology only, the inference is that the Dow soils are poorly drained. But they occur in positions on the landscape where poor drainage would be precluded. Other work (52, pp. 346-347; 53, p. 272) has shown that the gray color of the deoxidized zone is a relict feature and that zones of water saturation do not occur under the present climate. The gray color, therefore, was inherited from the parent materials, and the soils are well drained.

The morphology of a Dow soil on a Recent valley slope in the upper deoxidized and unleached zone (figs. 83: D.5, 1.38; 84, P-602) is:

P-602: slope, 11 percent, convex; cultivated field.

A₁₀ 0-5 inches	Very dark grayish brown (2.5Y 3/2) light silty clay loam; weak fine granular structure; friable; leached Tazewell loess; abrupt boundary.
AB 5-9 inches	Dark grayish brown (2.5Y 4/2) light silty clay loam with some mixing of very dark grayish brown (2.5Y 3/2); weak medium subangular blocky structure; friable; clear boundary.
B₂ 9-17 inches	Dark grayish brown (2.5Y 4/2) heavy silt loam; few fine and medium strong brown and yellowish red (7.5YR 5/6 and 5YR 4/6) pipestems; weak fine and medium blocky structure; friable; gradual boundary.

B ₁ 17-26 inches	Grayish brown (2.5Y 5/2) heavy to medium silt loam; common pipestems of strong brown and yellowish red (7.5YR 5/8 and 5YR 4/6); weak medium to coarse blocky structure; friable when moist and hard when dry; gradual boundary.
C ₁ 26-30 inches	Grayish brown (2.5Y 5/2) medium silt loam; common strong brown and yellowish red (7.5YR 5/8 and 5YR 4/6) pipestems; massive; friable; clear boundary.
C ₂₁ 30-35 inches	Grayish brown (2.5Y 5/2) medium silt loam; common strong brown and yellowish red pipestems; massive; friable; few carbonate concretions; the matrix appears to be leached; clear boundary.
C ₂₂ 35-80 inches	Grayish brown (2.5Y 5/2) medium silt loam; many strong brown and yellowish red pipestems; massive; friable; calcareous; many white carbonate concretions < 1/4 inch in diameter; base of the deoxidized and unleached zone; clear boundary.
C ₂₃ 80+ inches	Dark yellowish brown (10YR 4/4) medium silt loam; massive; friable; calcareous. The C ₂₃ horizon is the lower oxidized and unleached zone.

The Monona-Dow intergrade soils are similar to the Monona soils in both texture and color of the sola but the C horizons are the same as those of the Dow. The description of one in the upper deoxidized zone (fig. 83: C.96, 2.83) follows:

Monona-Dow Intergrade soil: slope, 10 percent, convex; cultivated field.

A _{1P} 0-6 inches	Very dark brown (10YR 2/2) heavy silt loam; weak fine granular structure; friable; leached Tazewell loess; abrupt boundary.
AB 6-11 inches	Very dark grayish brown (10YR 3/2) heavy silt loam with few dark grayish brown (10YR 4/2) spots; weak fine granular to subangular blocky structure; friable; gradual boundary.
B ₂ 11-19 inches	Dark grayish brown (10YR 4/2) heavy silt loam; weak fine subangular blocky structures; friable; gradual boundary.
B ₃ 19-25 inches	Dark grayish brown (10YR 4/2) medium silt loam with loam; common grayish brown and strong brown (2.5Y 5/2 and 7.5YR 4/5) mottles that increase in number with depth; weak medium blocky structure; few loose pipestems in upper part, increasing in number with depth; friable; gradual boundary.
C ₁ 25-34 inches	Grayish brown (2.5Y 5/2) medium silt loam; few to common yellowish red and dark reddish brown (5YR 4/8 and 3/4) mottles; massive; friable; few to common, loose to slightly hard strong brown and dark reddish brown (7.5YR 5/8 and 5YR 3/4) pipestems; clear boundary.
C ₂ 34 inches	Grayish brown (2.5Y 5/2) medium silt loam; few to common yellowish red and dark reddish brown (5YR 4/8 and 3/4) mottles; massive; friable; calcareous Tazewell loess; many soft to slightly hard strong brown and dark reddish brown (7.5YR 5/8 and 5YR 3/4) pipestems.

Pipestems are absent in the A₁ and B₂ horizons of the Monona-Dow intergrade soils but there are a few remnants in the B₃ and C₁ horizons. The pipestems in the B₃ horizon are loose and crumble when the surrounding soil is removed. In the C₂ horizon they are soft to slightly hard, and in the C₁ their consistence is transitional between those in the B₃ and C₂ horizons. The absence of pipestems in the upper sola and their presence in the lower sola and C horizons indicate that they have been weathered and dispersed. Thus, release of iron by weathering of primary minerals or pipestems can account for the brown colors of these soils. The Monona-Dow intergrade was not sampled for laboratory study.

Ida soils are in the oxidized and unleached zone of the loess and have an A-C profile and carbonates within 6 inches of the surface. Their areas were small (fig. 83: B.6, 1.72) and they were not sampled for laboratory study.

Napier soils, unit 3, are in alluvium on the valley floor and sides in and around waterways on slopes up to 9 percent (fig. 83, 3). Undifferentiated soils, unit 5, are on the level areas of alluvium near Middle Silver Creek but their areas were small and they were not studied.

A Napier soil on a strongly sloping site (fig. 83: C.82, 3.0) has the following morphology:

P-604: slope, 8 percent, concave; cultivated field.

A _{1p} 0-6 inches	Very dark brown (10YR 2/2) light silty clay loam; weak fine granular structure; friable; leached alluvium; abrupt boundary.
A _{1z} 6-18 inches	Very dark brown to very dark gray (10YR 2/2 to 3/1) light silty clay loam; weak fine granular structure; friable; gradual boundary.
AB 18-24 inches	Very dark brown (10YR 2/2) light silty clay loam; weak fine to medium subangular blocky structure; friable; gradual boundary.
B ₂₁ 24-37 inches	Very dark grayish brown (10YR 3/2) light silty clay loam; weak fine subangular blocky structure; friable; gradual boundary.
B ₂₂ 37-53 inches	Very dark grayish brown (10YR 3/2) light silty clay loam; weak fine to medium subangular blocky structure; friable; gradual boundary.
B ₃ 53-72 inches	Very dark grayish brown (10YR 3/2) light silty clay loam to heavy silt loam; weak medium blocky structure; interior of peds dark brown (10YR 3/3); friable; gradual to diffuse boundary.
C ₁ 72-160 inches	Dark grayish brown (10YR 4/2) heavy silt loam to light silty clay loam; few fine faint strong brown mottles; massive; friable; base of alluvial fill; clear boundary.
D 160+ inches	Grayish brown (2.5Y 5/2) medium silt loam; massive; friable; calcareous, Tazewell loess.

The morphology of a Napier soil near valley-side waterway (fig. 83: C.75, 3.1) is:

P-605: slope, 4 percent; cultivated field.

A ₁ 0-18 inches	Very dark gray (10YR 3/1) light silty clay loam; cloddy structure that breaks to weak fine granular; friable; leached alluvium; gradual boundary.
AB 18-24 inches	Very dark gray (10YR 3/1) light silty clay loam; weak fine subangular blocky structure; friable; gradual boundary.
B ₂₁ 24-32 inches	Very dark grayish brown (10YR 3/2) light silty clay loam; very weak fine subangular blocky structure; friable; gradual boundary.
B ₂₂ 32-44 inches	Very dark grayish brown (10YR 3/2) light silty clay loam; weak fine and medium subangular blocky structure; when dry the peds are ranged in weak medium to coarse prisms; friable; gradual boundary.
B ₃ 44-72 inches	Dark brown (10YR 3/3) light silty clay loam; weak medium blocky structure; friable; diffuse boundary.
C 72-204 inches	Dark grayish brown (10YR 4/2) light silty clay loam; massive; friable; base of alluvium; clear boundary.
D 204+ inches	Loveland loess.

Soils of the Tazewell and Recent surfaces in loess have several morphological properties in common. A horizons are very dark brown (10YR 2/2) to very dark gray (10YR 3/1); B horizons have weakly developed subangular blocky structure. The master horizons are separated by 4- to 6-inch transition zones. The general sequence of horizons is the same. The differences in morphology are the thick sola of soils in the upper leached zone compared to those in the unleached zones and the gray color of the B horizons of soils in the deoxidized zones. The Napier soils have

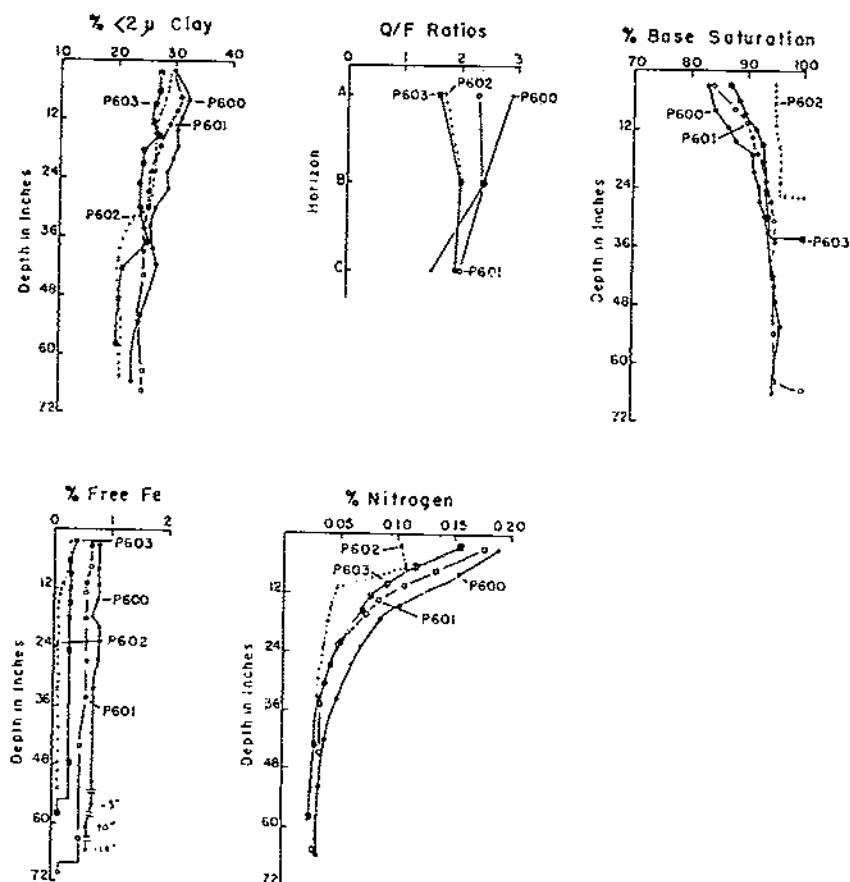

FIGURE 85.—Distribution with depth of clay ($< 2\mu$), quartz/feldspar ratios, percent base saturation, free iron, and nitrogen of soils in Tazewell loess. P-600, Marshall; P-601 and P-603, Monona; P-602, Dow.

thicker A, horizons and sola and lower chroma and value colors in the B horizons than the associated loess-derived soils. These differences between the soils probably are the result of accretion of parent material during the formation of the Napier. Other morphological properties such as structure and horizon sequence are similar to the loess-derived soils and the Napier soils are classified as Brunizems (65, p. 179).

Physical and Chemical Properties

Clay content¹⁹ of the loess-derived soils decreases gradually with depth from a maximum in the AB or A_n horizons (fig. 85). Among the loess-derived soils the largest amount of clay is in the Marshall and Monona soils in the upper leached zone. These differences between soils in the leached and unleached zones may

¹⁹ The pipette method (27) was used for particle size analysis.

TABLE 41.—Physical, chemical, and mineralogical data of Marshall profile P-600

Sample No.	Depth	Horizon	Particle-size distribution			<2 μ	Ratio 50-20/ 20-2	Mineralogical data ¹			pH	Ex- change- bases	Ex- change- able hydro- gen	Ex- change ca- pacity	Ex- change ca- pacity of clay	Base satura- tion	Ni- trogen	Free iron ²
			>50 μ	50-20 μ	20-2 μ			Quartz	Feld- spar ³	Quartz- feld- spar ratio								
	Inches		Percent	Percent	Percent	Percent		Percent 75	Percent 25			meq/ 100g	meq/ 100g	meq/ 100g	Percent	Percent	Percent	
P-600-1	0-6	A _{1p}	2.9	34.9	32.7	29.5	1.1			2.9	5.8	19.0	3.9	22.9	78	83.0	0.187	0.8
-2	6-10	AB	2.3	31.3	33.9	32.5					5.8	20.3	3.8	24.1	74	84.2	.154	.8
-3	10-13	B ₂₁	2.2	32.0	34.4	31.4	.9	71	29	2.4	6.0	20.6	3.1	23.7	75	86.9	.128	.8
-4	13-16	B ₂₁	1.6	33.7	34.4	30.3	1.0				6.1	21.2	2.8	24.0	79	88.3	.102	.7
-5	16-19	B ₂₂	1.6	33.6	34.4	30.4	1.0				6.2	21.1	2.1	23.2	76	90.9	.086	.8
-6	19-22	B ₂₂	1.5	32.7	36.0	29.8	.9				6.3	21.1	1.8	22.9	79	92.1	.068	.8
-7	22-25	B ₂₂	3.0	38.6	29.6	28.8	1.3				6.3	21.1	1.8	22.9	79	92.1	.068	.8
-8	25-28	B ₂₁	4.2	37.6	29.1	29.1	1.3				6.4	22.0	1.9	23.9	82	92.0	.060	.8
-9	28-31	B ₂₁	4.6	38.2	30.7	26.5	1.2				6.4	22.4	1.6	24.0	90	93.3		.7
-10	31-35	B ₂₁	3.9	39.2	31.0	25.9	1.3				6.5	21.5	1.4	22.9	88	93.9	.045	.7
-11	35-40	BC	3.3	37.8	32.8	26.1	1.2				6.4	22.8	1.4	24.2	92	94.2		.7
-12	40-45	BC	2.2	35.7	35.3	26.8	1.0				6.4	23.3	1.3	24.6	88	94.7	.037	.7
-13	45-50	C ₁									6.4	21.9	1.1	23.0		95.2		.7
-14	50-55	C ₁	2.2	39.0	33.5	25.3	1.2				6.5	22.2	0.9	23.1	91	96.1	.034	.7
-15	60-72	C ₁									6.4	23.4	1.1	24.5		95.5		.7
-16	60-72	C ₁	5.4	40.2	31.1	23.3	1.3	60	40	1.5	6.5	22.0	1.2	23.2	100	95.8	.032	.7
-17	72-84	C ₁									6.5	21.5	1.2	22.7		94.7		.6
-18	84-96	C ₁	3.6	40.9	32.4	23.1	1.3				6.7	21.1	1.1	22.2	95	95.0		.6
-19	96-108	C ₁									6.7	23.5	1.0	24.5		95.9		.6
-20	108-120	C ₁	2.6	40.0	33.9	23.5	1.2				6.9	22.2	0.6	22.8	97	97.4		.6

¹ 31-62 micron silt. A minimum of 300 grains were counted. Traverses were made at equal intervals, and only those grains that touched the intersection of the cross hairs were counted.

² Orthoclase, microcline, plagioclase.

³ Expressed as Fe.

TABLE 42.—Physical, chemical, and mineralogical data of Monona profiles P-601 and P-603

Sample No.	Depth	Horizon	Particle-size distribution				Ratio 50-20/ 20-2	Mineralogical data ¹			pH	Ex- change- able bases	Ex- change- able hydro- gen	Ex- change ca- pacity	Ex- change ca- pacity of clay	Base satura- tion	Ni- trogen	Free iron ²
			>50 μ	50-20 μ	20-2 μ	<2 μ		Quartz	Feld- spar ³	Quartz- feld- spar ratio								
P-601-1	0-6	A ₁ P	2.4	37.3	30.7	29.6	1.2			2.3	5.8							
-2	6-9	A-B	3.2	34.7	30.8	31.3	1.1				5.9	20.4	3.9	24.3	82	84.0	0.176	
-3	9-12	B ₂₁	3.0	33.5	33.3	30.2	1.0				5.9	22.6	3.1	25.7	82	87.9	.134	
-4	12-15	B ₂₁	3.0	34.0	34.0	29.0	1.0	68	32	2.2	6.0	23.4	2.6	26.0	87	90.0	.105	
-5	15-18	B ₂₂	3.2	36.1	33.0	27.7	1.1				6.1	22.9	2.3	25.2	87	90.9	.086	
-6	18-21	B ₂₂	3.0	35.0	34.9	27.1	1.0				6.1	22.6	2.0	24.6	89	91.9	.074	
-7	21-25	B ₂	3.2	41.3	29.5	26.0	1.4				6.2	22.8	1.7	24.5	90	93.1	.6	
-8	25-29	B ₂	3.2	41.3	29.5	26.0	1.4				6.2	22.3	1.6	23.9	92	93.3	.048	
-9	29-33	B ₂	4.5	38.3	31.3	25.9	1.2				6.4	23.6	1.4	25.0	97	94.4	.6	
-10	33-37	B-C	4.3	35.4	34.8	25.5	1.0				6.4	23.2	1.3	24.5	96	94.7	.6	
-11	37-41	B-C	2.8	37.1	35.4	24.7	1.0				6.5	22.8	1.3	24.1	98	94.6	.6	
-12	41-48	C ₁	2.7	36.3	36.4	24.6	1.0				6.5	22.2	1.4	23.6	96	94.1	.6	
-13	48-60	C ₁	2.4	34.9	37.8	24.9	.9				6.7	22.6	1.2	23.8	96	95.0	.5	
-14	60-68	C ₁	2.7	34.4	38.9	24.0	.9	67	33	2.1	6.6	22.1	1.1	23.2	97	95.2	.6	
-15	68+	D	3.0	31.8	40.0	25.2	.8				6.8	22.8	1.2	24.0	94	95.0	.5	
P-603-1	0-5	A ₁ P	3.2	33.4	38.1	25.3	.9				7.6				100.0	.028	.1	
-2	5-8	A-B	2.0	46.7	23.9	27.4	2.0	62	38	1.6	6.0	20.5	3.0	23.5	85	87.2	.155	
-3	8-11	B ₂₁	2.6	45.3	24.6	27.5	1.8				6.1	20.7	2.7	23.4	85	88.5	.116	
-4	11-14	B ₂₁	2.7	47.0	23.7	26.6	2.0				6.2	20.4	2.4	22.8	86	89.5	.092	
-5	14-17	B ₂₂	2.0	46.0	25.6	26.4	1.8	67	33	2.0	6.3	20.4	1.9	22.3	84	91.5	.079	
-6	17-20	B ₂₂	1.4	43.3	27.8	27.5	1.6				6.2	20.6	1.6	22.2	81	92.8	.3	
-7	20-23	B ₂₂	2.9	44.7	27.8	24.6	1.8				6.3	19.7	1.6	21.3	86	92.5	.3	
-8	23-28	B ₂	2.9	46.0	26.2	24.9	1.8				6.3	20.6	1.5	22.1	86	93.2	.052	
-9	28-34	B ₂	2.3	42.5	31.0	24.2	1.4				6.4	20.4	1.4	21.8	91	93.6	.3	
-10	34-35	C _{ca}	1.8	45.4	28.5	24.3	1.6				6.6	20.8	1.4	22.2	90	93.7	.039	
-11	35-40	C	2.2	40.3	31.9	25.6	1.3				7.7				100.0			
-12	40-46	C	1.5	48.2	29.0	21.3	1.7	65	35	1.9	7.8				100.0	.028		
-13	46-52	C	1.8	50.6	26.8	20.8	1.9				7.7				100.0		.3	
-14	52-64	D	1.8	51.0	26.7	20.5	1.9				7.9				100.0	.024	.1	

¹ 31-62 micron silt.

² Orthoclase, microcline, plagioclase.

³ Expressed as Fe.

TABLE 43.—Physical, chemical, and mineralogical data of Dow profile P-602

Sample No.	Depth	Horizon	Particle-size distribution			<2 μ	Ratio 50-20/ 20-2	Mineralogical data ¹			pH	Ex- change- able bases	Ex- change- able hydro- gen	Ex- change ca- pacity	Ex- change ca- pacity of clay	Base satura- tion	Ni- trogen	Free iron ²
			>50 μ	50-20 μ	20-2 μ			Quartz	Feld- spar ³	Quartz- feld- spar ratio								
	Inches		Percent	Percent	Percent	Percent		Percent	Percent		meq/ 100g	meq/ 100g		meq/ 100g	Percent	Percent	Percent	
P-602-1	0-5	A ₁ P	3.0	41.2	26.4	29.4	1.6	64	36	1.7	6.5	24.2	1.4	25.6	87	94.5	0.104	0.3
2	5-9	A-B	3.0	40.6	28.1	28.3	1.4				6.5	24.6	1.3	25.9	92	95.0	.108	.3
3	9-13	B ₁	2.8	39.5	30.2	27.5	1.3				6.6	23.9	1.2	25.1	91	95.2	.048	.2
4	13-17	B ₂	3.2	38.8	31.1	26.9	1.2	65	35	2.0	6.5	23.9	1.0	24.9	93	96.0	.042	.1
5	17-21	B ₃	3.2	39.9	29.7	27.2	1.3				6.5	23.9	1.0	24.9	92	96.0		
6	21-26	B ₄	2.9	40.0	30.7	26.4	1.3				6.5	24.1	1.0	25.1	95	96.0	.035	
7	26-30	C ₁	2.5	39.2	32.4	25.9	1.2				7.8					100.0		
8	30-35	C ₂	2.5	44.4	30.0	23.1	1.5				7.8					100.0	.034	.1
9	35-47	C ₃	2.3	47.0	30.2	20.5	1.6	65	35	1.9	7.8					100.0		
10	47-59	C ₄	1.7	45.1	32.0	21.2	1.4				8.0					100.0	.026	.1
11	59-71	C ₅	3.4	47.0	31.9	21.1	1.5				7.8					100.0		

¹ 31-62 micron silt.² Orthoclase, microcline, plagioclase.³ Expressed as Fe.

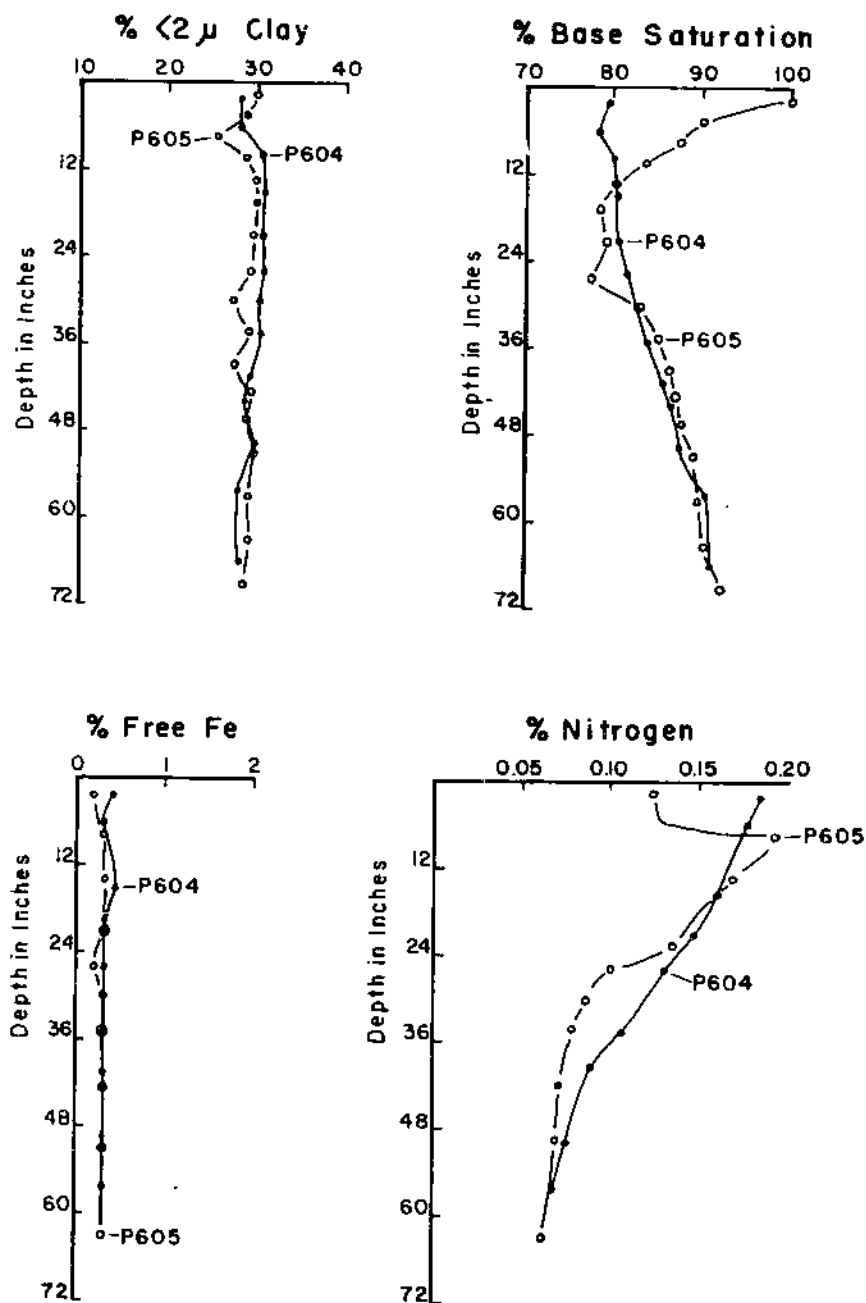

FIGURE 86.—Distribution with depth of clay ($<2\mu$), percent base saturation, percent free iron, and percent nitrogen of Napier profiles P-604 and P-605.

be due to less clay in the C horizons or to carbonate slowing the breakdown of material to clay size in the unleached zone.

Quartz, feldspar ratios of the Marshall soil decrease with depth, and some weathering of the coarse silt fraction in the A horizon is indicated. In Monona and Dow soils, quartz/feldspar ratios are random and indicate little weathering of feldspars.

Examination of clay curves and quartz, feldspar ratios (tables 41, 42, 43) suggests that clay has formed in the solum. The clay may have weathered either from heavy minerals in coarse silt or from minerals and feldspars in fine silt, or from both. But other interpretations of these data are possible.

Total cation exchange capacity is about the same throughout the solum. Cation exchange capacity should be largest in the clay maximum, however, because the clays of loess and modern soils are dominantly montmorillonite and have moderate amounts of illite and traces of kaolinite (ch. 1). When the exchange capacity of the soil is assigned to the clay fraction, horizons of maximum clay have the lowest and C horizons the highest exchange capacity per 100 grams of clay (tables 41, 42, 43). Cation exchange capacity in C horizons is higher than would be expected from the mineralogy of the clays and is evidence for the interpretation that the silt fraction is contributing to exchange capacity. Since quartz, feldspars, and heavy minerals have little cation-exchange capacity, clay minerals may occur in the silt fraction as aggregates, discrete silt-size grains, or cemented on silt grains. Silt grains from C horizons commonly are completely or partially coated with a weakly birefringent material that is not removed by dispersing agents or by treatment to remove free iron oxides. Thus, the increase in clay content in the solum of the loess-derived soils does not necessarily mean that clay minerals are being formed by weathering from primary minerals. The increase may be the result of more complete dispersion during particle-size analysis.

Napier soils have about the same clay content throughout the sola (fig. 86; table 44). Lack of a clay bulge in Napier and its presence in loess-derived soils is anomalous because soils of the Recent surface have about the same age. Accretion of material on the valley floor should not delay clay formation any more than erosion on valley slopes would delay it. The alluvium was derived by erosion of loess and the mineral assemblages should be similar. Weathering of Napier in the more moist environment on the lower concave valley slopes should be more intensive than of soils in loess on convex slopes. If clay minerals are not being formed by weathering of primary minerals in loess but occur as aggregates of silt size or on grains of silt, lack of a clay bulge in Napier could be due to dispersion of clay in loess before or during its deposition as alluvium. Later weathering of alluvium apparently has not broken down feldspars and other primary minerals to clay or to synthesized clays.

From data available the problem of clay formation in loess and alluvium-derived soils cannot be settled. The apparent absence of clay formation in soils in alluvium, however, should not be used

TABLE 44.—Physical, chemical, and mineralogical data of Napier profiles P-604 and P-605

Sample No.	Depth	Horizon	Particle-size distribution				Ratio 50-20/ 20-2	Mineralogical data ¹			pH	Ex- change- able bases	Ex- change- able hydro- gen	Ex- change ca- pacity	Ex- change ca- pacity of clay	Base satura- tion	Ni- trogen	Free iron ¹
			>50 μ	50-20 μ	20-2 μ	<2 μ		Quartz	Feld- spar ²	Quartz- feld- spar ratio								
	Inches		Percent	Percent	Percent	Percent	Percent	Percent			meq/ 100g	meq/ 100g	meq/ 100g	Percent	Percent	Percent		
P-604-1	0-4	A _{1P}	3.0	46.6	22.2	28.2	2.1											
-2	4-8	A ₁₂	2.4	47.0	22.6	28.0	2.1				5.5	18.6	4.8	23.4	83	79.5	0.181	
-3	8-12	A ₁₂	2.7	43.0	23.8	30.5	1.8				5.4	18.3	5.1	23.4	84	78.2	.174	
-4	13-18	A ₁₂	2.6	43.2	23.4	30.8	1.8				5.5	20.4	5.1	25.5	84	80.0		
-5	18-24	A-B	2.8	43.9	22.8	30.5	1.9				5.7	19.6	4.7	24.3	79	80.6	.100	
-6	24-28	B ₂₁	3.8	42.1	23.4	30.7	1.8				5.6	19.4	4.7	24.1	79	80.5	.146	
-7	28-32	B ₂₁	3.6	42.1	24.1	30.2	1.7				5.7	18.6	4.2	22.8	74	81.6	.130	
-8	32-37	B ₂₁	2.8	43.5	23.3	30.4	1.9				5.7	19.0	4.0	23.0	76	82.6		
-9	37-42	B ₂₂	2.9	44.2	23.5	30.4	1.9				5.8	19.4	3.7	23.1	76	84.0	.105	
-10	42-47	B ₂₂	2.1	44.4	24.7	29.9	1.9				5.8	20.1	3.3	23.4	80	85.9	.088	
-11	47-53	B ₂₂	2.8	42.9	24.4	28.8	1.8				6.0	20.4	3.1	23.5	82	86.8		
-12	53-60	B ₂	2.8	44.4	25.1	27.7	1.8				5.9	20.5	2.9	23.4	78	87.6	.074	
-13	60-72	B ₂	3.0	43.6	25.4	28.0	1.7				6.0	20.1	2.2	22.3	81	90.1	.066	
-14	72-84	C ₁	3.9	44.0	25.0	27.1	1.8				6.0	20.2	2.1	22.3	80	90.6		
-15	84-96	C ₁	3.1	41.4	27.0	28.5	1.5				6.3	20.1	1.8	21.9	81	91.8	.051	
-16	96-108	C ₁	1.8	41.1	27.5	29.6	1.5				6.2	21.2	1.9	23.1	81	91.8		
P-605-1	0-3	A ₁	2.0	40.0	28.0	30.0	1.4				6.4	22.3	1.9	24.2	82	92.1	.051	
-2	3-6	A ₁	2.6	44.9	23.9	28.6	1.9				7.2					100.0	.121	
-3	6-9	A ₁	3.7	47.2	23.8	25.3	2.0				6.4	21.5	2.4	23.9	84	90.0		
-4	9-12	A ₁	2.6	44.9	23.7	28.8	1.9				6.3	21.0	3.0	24.0	95	87.5	.102	
-5	12-15	A ₁	2.6	44.1	23.3	30.0	1.8				5.9	20.3	4.0	24.3	81	83.5		
-6	15-18	A ₁	2.9	43.9	23.0	30.2	1.9				5.6	19.4	4.7	24.1	80	80.5	.169	
-7	18-24	A-B	2.3	44.2	23.7	29.8	1.9				5.5	18.5	5.1	23.6	78	78.4		
-8	24-28	B ₂₁	2.8	43.7	24.3	29.2	1.8				5.6	17.9	4.7	22.6	76	79.2	.133	
-9	28-32	B ₂₁	3.3	43.9	25.4	27.4	1.7				5.5	17.8	4.2	23.0	79	77.4	.100	
-10	32-36	B ₂₂	2.0	48.7	20.2	29.1	2.4				5.5	18.1	3.6	21.7	76	83.4	.085	
-11	36-40	B ₂₂	4.7	49.7	18.0	27.6	2.8				5.4	18.0	3.1	21.1	73	85.3	.077	
-12	40-44	B ₂₂	4.7	48.5	17.5	29.3	2.8				5.7	18.0	2.8	20.8	75	86.5		
-13	44-48	B ₂	3.6	43.5	24.0	28.9	1.8				5.7	19.5	2.9	22.4	76	87.0	.070	
-14	48-54	B ₂	3.0	42.9	24.2	29.9	1.8				5.7	19.7	2.7	22.4	78	87.9		
-15	54-60	B ₂	3.4	45.0	22.4	29.2	2.0				5.8	20.2	2.4	22.1	74	89.1	.069	
-16	60-66	B ₂	3.3	44.6	23.0	29.1	1.9				5.9	20.1	2.3	22.5	77	89.8		
-17	68-72	B ₂	3.4	45.3	22.5	28.8	2.0				5.9	20.1	2.1	22.2	76	90.5	.061	
-18	72-84	C ₁	3.9	46.6	22.0	27.5	2.1				5.9	19.9	1.7	21.6	75	92.1	.3	
											5.9	20.2	1.4	21.6	79	93.5	.050	

¹ Expressed as Fe.

as an indication of weak development until more is known about clay formation in alluvial environment.

Distribution of free iron indicates little translocation of iron within the sola. The amount of free iron in loess-derived soils is highest in Marshall and Monona soils in the upper leached zone and lowest in the Dow soil in the deoxidized zones. Free iron of the soils, therefore, appears to be more closely related to free iron content of parent material. This, in turn, is related to its past history of oxidization and reduction. Free iron of soils in alluvium reflect free iron of the parent material. Apparently Napier soils have not been subjected to severe reducing conditions and iron movements.

Decrease in nitrogen⁵⁰ with depth in the loess-derived soils is similar to other soils classified as Brunizems (76, p. 505). Except for the more gradual nitrogen decrease with depth in the upper 24 to 30 inches in Napier soils, the nitrogen content and distribution are similar to soils in loess.

Degree of base saturation⁵¹ of Marshall and Monona soils and of Napier soil P-604 increases gradually with depth. On the other hand, the base saturation of the Dow soil is almost constant with depth and in Napier soil P-605 decreases from the A to the B horizon. Monona soil P-603 and the Dow are in unleached zones of the loess and their slope gradients are similar. Thus, either the parent material of the Dow had a higher carbonate content at the start of soil formation or the Dow site was eroded later than the site of Monona P-603. High base status and low nitrogen content in the surface of Napier soil P-605 indicate base-rich postsettlement alluvium has been added to its surface.

Similarity of base saturation of Marshall and Monona soils shows that about as much hydrogen enters into the exchange complex in less than 6,800 years as in about 14,000 years. Apparently loss of bases is rapid during the initial stages of formation in these soils. But later, either release of bases by weathering or recycling by vegetation maintains the system at a nearly steady state. Similarities between base saturation curves of loess-derived and Napier soils indicate that the degree of horizon development in Napier soils is as great as in soils in loess although the Napier material may have been weathered before it was transported to its present position.

Summary and Conclusions

Post Tazewell erosion of the valley slopes, and locally the ridges, in the vicinity of cut 39 has exposed the sequence of loess zones, left the Tazewell surface several feet above the valley floor, and furnished material for the alluvial fill on the valley floor.

⁵⁰ Nitrogen was determined by a modified Kjeldahl method (3) using boric acid for collection of the distillate.

⁵¹ Total exchangeable bases were determined according to the procedure by Black (3). Exchangeable hydrogen was determined by leaching the soil with neutral, normal barium acetate and titrating the acidity with sodium hydroxide.

Distribution of soils closely parallels the outcrop area of loess zones and the alluvial fill, and within a loess zone the geomorphic surfaces. Thus, landscape evolution through its exposure of different parent materials and control of distribution of geomorphic surfaces has influenced areal distribution of soils.

Soil landscape in the watershed is composed of several soil series with their distribution controlled in part by the geomorphology and stratigraphy of the area. Under present restrictions in the use of catena and toposequence, the soil landscape cannot be described using these terms (1, pp. 431, 440). Thus, the soil association area must be used to describe the soil landscape although the catena concept has been used for this purpose (37).

Geomorphic and other lines of evidence show that weathering histories of soils of Tazewell and Recent surfaces differ considerably. Marshall soils of the stable Tazewell surface started development more than 14,000 years ago under a forest vegetation that was replaced by grass about 6,800 years ago (31, 53, 54). They also weathered under the moist climatic regimes that produced the loess weathering zones. There is little in the morphology and physical or chemical properties of Marshall soils, however, that suggest a past forest vegetation. Thus, the change under forest was slight or the forest influence was destroyed during the grassland cycle.

In contrast to Marshall soils, Monona and Dow soils have formed under an erosion surface that is less than 6,800 years old. Grass has been the dominant vegetation of Monona and Dow soils. Monona soils in the upper leached zone formed in materials weathered during previous cycles whereas Monona and Dow soils below the upper leached zone formed in materials that probably were not affected by previous cycles of soil formation. These soils also may have had slow removal of material from the surface during their formation. Napier soils, on the other hand, may have had slow accretion of material on the surface, and the material may have been weathered to varying degrees before it was deposited as alluvium.

Similarity in physical and chemical properties between Marshall and Monona soils in the upper leached zone indicates that almost as much soil differentiation can occur in leached loess in less than 6,800 years as in about 14,000 years. Although soils in the unleached zones do not have as much physical and chemical differentiation as soils in the leached zone, differences are a matter of degree rather than kind. Under past and present weathering intensity, soil formation in loess in the Marshall area is relatively rapid and degree of soil differentiation is not a linear function of time.

Literature Cited

- (1) ALDRICH, D. G., et al.
1956. REPORT OF DEFINITIONS APPROVED BY THE COMMITTEE ON TERMINOLOGY. Soil Sci. Soc. Amer. Proc. 20: 430-440.

- (2) BARNES, B. A., GRANT, L. H., and RIECKEN, F. F.
1953. BRIEF DESCRIPTIONS OF SOIL UNITS USED IN SOIL SURVEYS IN SOIL CONSERVATION DISTRICTS, IOWA. Iowa Agr. Expt. Sta., 44 pp. (Mimeo.)
- (3) BLACK, C. A.
1955. LABORATORY METHODS OF SOIL INVESTIGATIONS. Dept. of Agr. Iowa State College, Ames, Iowa. 53 pp., illus. (Mimeo.)
- (4) BRAY, R. H.
1934. A CHEMICAL STUDY OF SOIL DEVELOPMENT IN THE PEORIAN LOESS REGION OF ILLINOIS. Amer. Soil Survey Assoc. Bull. 15: 58-65, illus.
- (5) _____
1935. THE ORIGIN OF HORIZONS IN CLAYPAN SOILS. Amer. Soil Survey Assoc. Bull. 16: 70-75, illus.
- (6) BRYAN, K.
1923. EROSION AND SEDIMENTATION IN THE PAPAGO COUNTRY, ARIZONA. U.S. Geol. Survey Bull. 730: 19-90, illus.
- (7) _____
1940. THE RETREAT OF SLOPES. Amer. Assoc. Geo. Annals 30: 254-268, illus.
- (8) _____
1940. GULLY GRAVURE—A METHOD OF SLOPE RETREAT J. Geomor. 3: 89-107, illus.
- (9) BYERS, H. G., KELLOGG, C. E., ANDERSON, M. S., and THORP, J.
1938. FORMATION OF SOIL. In U.S. Dept. Agr. Ybk., 1938, pp. 948-978, illus.
- (10) CORLISS, J. F., and RUHE, R. V.
1955. THE IOWAN TERRACE AND TERRACE SOILS OF THE NISHNABOTNA VALLEY IN WESTERN IOWA. Iowa Acad. Sci. Proc. 62: 354-360, illus.
- (11) DAVIS, W. M.
1899. THE GEOGRAPHICAL CYCLE. Geog. J. 14: 481-504, illus. *Republished in* Geographical Essays. 777 pp. 1954. Dover, New York.
- (12) _____
1932. PIEDMONT BENCHLANDS AND PRIMARRUMPFE Geol. Soc. Amer. Bull. 43: 399-440, illus.
- (13) DRYDEN, L., and DRYDEN, C.
1946. COMPARATIVE RATES OF WEATHERING OF SOME COMMON HEAVY MINERALS. J. Sed. Petrology 16: 91-96, illus.
- (14) FLINT, R. F., and DEEVEY, E. S.
1951. RADIOCARBON DATING OF LATE-PLEISTOCENE EVENTS. Amer. J. Sci. 249: 257-300, illus.
- (15) FRYE, J. C.
1954. GRADED SLOPES IN WESTERN KANSAS. Kansas Geol. Survey Bull. 109: 85-96, illus.
- (16) _____
1954. SOME PROBLEMS OF ALLUVIAL TERRACE MAPPING. Amer. J. Sci. 252: 242-251, illus.

- (17) ——— and LEONARD, A. B.
1952. PLEISTOCENE GEOLOGY OF KANSAS. Kansas Geol. Survey Bull. 99: 230 pp., illus.
- (18) GOLDICH, S. S.
1938. A STUDY IN ROCK WEATHERING. J. Geol. 46: 17-58, illus.
- (19) HOLMES, C. D.
1955. GEOMORPHIC DEVELOPMENT IN HUMID AND ARID REGIONS: A SYNTHESIS. Amer. J. Sci. 253: 377-390, illus.
- (20) HOWARD, A. D.
1942. PEDIMENT PASSES AND THE PEDIMENT PROBLEM. J. Geomor. 5: 3-31, illus.
- (21) HUTTON, C. E.
1947. STUDIES OF LOESS-DERIVED SOILS IN SOUTHWESTERN IOWA. Soil Sci. Soc. Amer. Proc. 12: 424-431, illus.
- (22) ———
1950. STUDIES OF THE CHEMICAL AND PHYSICAL CHARACTERISTICS OF A CHRONO-LITHO-SEQUENCE OF LOESS-DERIVED PRAIRIE SOILS OF SOUTHWESTERN IOWA. Soil Sci. Soc. Amer. Proc. 15: 318-324, illus.
- (23) JEFFRIES, C. D.
1946. A RAPID METHOD FOR REMOVAL OF FREE IRON OXIDES IN SOIL PRIOR TO PETROGRAPHIC ANALYSIS. Soil Sci. Soc. Amer. Proc. 11: 211-212.
- (24) KAY, G. F.
1916. GUMBOTIL, A NEW TERM IN PLEISTOCENE GEOLOGY. Sci., new ser. 44: 637-638.
- (25) ——— and APFEL, E. T.
1929. THE PRE-ILLINOIAN PLEISTOCENE GEOLOGY OF IOWA. Iowa Geol. Survey 34: 1-304, illus.
- (26) ——— and GRAHAM, J. B.
1943. THE ILLINOIAN AND POST-ILLINOIAN PLEISTOCENE GEOLOGY OF IOWA. Iowa Geol. Survey 38: 1-262, illus.
- (27) KILMER, V. J., and ALEXANDER, L. T.
1949. METHODS OF MAKING MECHANICAL ANALYSIS OF SOILS. Soil Sci. 68: 15-24.
- (28) ——— and MULLINS, J. F.
1954. IMPROVED STIRRING AND PIPETTING APPARATUS FOR MECHANICAL ANALYSIS OF SOILS. Soil Sci. 77: 437-441, illus.
- (29) KING, L. C.
1953. CANONS OF LANDSCAPE EVOLUTION. Geol. Soc. Amer. Bull. 64: 721-752, illus.
- (30) KRUMBEIN, W. C.
1937. SEDIMENTS AND EXPONENTIAL CURVES. J. Geol. 45: 577-601, illus.

- (31) LANE, G. H.
1931. A PRELIMINARY POLLEN ANALYSIS OF THE EAST McCULLOCH PEAT BED. *Ohio J. Sci.* 31: 165-171, illus.
- (32) ———
1941. POLLEN ANALYSIS OF INTERGLACIAL PEATS OF IOWA. *Iowa Geol. Survey* 37: 237-262, illus.
- (33) LEIGHTON, M. M., and WILMAN, H. B.
1950. LOESS FORMATIONS OF THE MISSISSIPPI VALLEY. *J. Geol.* 58: 599-623, illus.
- (34) LEONARD, A. B.
1952. MOLLUSCA-ILLINOIAN AND WISCONSINIAN MOLLUSCAN FAUNAS IN KANSAS. *Kansas Univ. Paleo. Contrib.* 4: 1-38, illus.
- (35) ——— and FRYE, J. C.
1954. ECOLOGICAL CONDITIONS ACCOMPANYING LOESS DEPOSITION IN THE GREAT PLAINS REGION OF THE UNITED STATES. *J. Geol.* 62: 399-404.
- (36) MILLER, W. L.
1916. TOPOGRAPHY, BOONE QUADRANGLE, IOWA. *U.S. Geol. Survey*.
- (37) MILNE, G.
1936. A PROVISIONAL SOIL MAP OF EAST AFRICA. *East African Agr. Res. Sta., Amani Memoirs*, 34 pp., illus.
- (38) MICKELSON, J. C.
1950. A POST-LOVELAND PRE-IOWAN LOESS IN WESTERN IOWA. *Iowa Acad. Sci. Proc.* 57: 267-269.
- (39) NIKIFOROFF, C. C.
1949. WEATHERING AND SOIL EVOLUTION. *Soil Sci.* 67: 219-230.
- (40) O'NEAL, A. M., and DEYOL, A. M.
1923. SOIL SURVEY OF BOONE COUNTY, IOWA. *U.S. Dept. Agr. Bur. Soils*: 135-166, illus.
- (41) PEECH, M., ALEXANDER, L. T., DEAN, L. A. and REED, J. F.
1949. METHODS OF SOIL ANALYSIS FOR SOIL-FERTILITY INVESTIGATIONS. *U.S. Dept. Agr. C.* 757, 25 pp.
- (42) RIECKEN, F. F., and SMITH, G. D.
1949. PRINCIPAL UPLAND SOILS OF IOWA. *Iowa Agr. Expt. Sta.* 49, 42 pp., illus. (Mimeo.)
- (43) RUBIN, M., and SUESS, H. E.
1955. U.S. GEOLOGICAL SURVEY RADIOCARBON DATES II. *Sci.* 121: 481-488.
- (44) ——— and SUESS, H. E.
1956. U.S. GEOLOGICAL SURVEY RADIOCARBON DATES III. *Sci.* 123: 442-448.
- (45) RUHE, R. V.
1952. CLASSIFICATION OF THE WISCONSIN GLACIAL STAGE. *J. Geol.* 60: 398-401, illus.
- (46) ———
1954. PLEISTOCENE SOILS ALONG THE ROCK ISLAND RELOCATION IN SOUTHWESTERN IOWA. *Amer. Railway Engin. Assoc. Bull.* 514: 639-645, illus.

- (47) ———
1954. RELATIONS OF THE PROPERTIES OF WISCONSIN LOESS TO TOPOGRAPHY IN WESTERN IOWA. *Amer. J. Sci.* 252: 663-672, illus.
- (48) ———
1956. GEOMORPHIC SURFACES AND THE NATURE OF SOILS. *Soil Sci.* 82: 441-455, illus.
- (49) ———
1956. LANDSCAPE EVOLUTION IN THE HIGH ITURI, BELGIAN CONGO. *Publ. de l'I.N.E.A.C., Bruxelles, ser. sci.* 66: 108 pp., illus.
- (50) ——— and CADY, J. G.
1954. LATOSOLIC SOILS OF CENTRAL AFRICAN INTERIOR HIGH PLATEAUS. 5th Intern. Cong. *Soil Sci. Trans., Leopoldville, 4: 401-407, illus.*
- (51) ——— and SCHOLTES, W. H.
1955. RADIOCARBON DATES IN CENTRAL IOWA. *J. Geol.* 63: 82-92, illus.
- (52) ———, PRILL, R. C., and RIECKEN, F. F.
1955. PROFILE CHARACTERISTICS OF SOME LOESS-DERIVED SOILS AND SOIL AERATION. *Soil Sci. Soc. Amer. Proc.* 19: 345-347, illus.
- (53) ——— and SCHOLTES, W. H.
1956. AGES AND DEVELOPMENT OF SOIL LANDSCAPES IN RELATION TO CLIMATIC AND VEGETATIONAL CHANGES IN IOWA. *Soil Sci. Soc. Amer. Proc.* 20: 264-273, illus.
- (54) ———, RUBIN, M., and SCHOLTES, W. H.
1957. LATE PLEISTOCENE RADIOCARBON CHRONOLOGY IN IOWA. *Amer. J. Sci.* 255: 671-689, illus.
- (55) ——— and DANIELS, R. B.
1958. SOILS, PALEOSOLS, AND SOIL HORIZON NOMENCLATURE. *Soil Sci. Soc. Amer. Proc.* 22: 66-69, illus.
- (56) SCHOLTES, W. H., RUHE, R. V., and RIECKEN, F. F.
1951. USE OF THE MORPHOLOGY OF BURIED SOIL PROFILES IN THE PLEISTOCENE OF IOWA. *Iowa Acad. Sci. Proc.* 58: 295-306, illus.
- (57) ———, SMITH, G. D., and RIECKEN, F. F.
1954. TAYLOR COUNTY, IOWA SOILS. *U.S. Dept. Agr. Soil Survey ser.* 1947, No. 1, 74 pp., illus.
- (58) SHRADER, W. D.
1950. DIFFERENCES IN THE CLAY CONTENTS OF SURFACE SOILS DEVELOPED UNDER PRAIRIE AS COMPARED TO FOREST VEGETATION IN THE CENTRAL UNITED STATES. *Soil Sci. Soc. Amer. Proc.* 15: 333-337, illus.
- (59) ———, SPRINGER, M. E., and HALL, N. S.
1953. SOIL SURVEY OF HOLT COUNTY, MISSOURI. *U.S. Dept. Agr. Soil Survey ser.* 1939, No. 21, 74 pp., illus.
- (60) SIMONSON, R. W.
1954. IDENTIFICATION AND INTERPRETATION OF BURIED SOILS. *Amer. J. Sci.* 252: 705-732, illus.

- (61) ———, RIECKEN, F. F., and SMITH, G. D.
1952. UNDERSTANDING IOWA SOILS. 142 pp., illus. W. C. Brown Co., Dubuque, Iowa.
- (62) ——— and HUTTON, C. E.
1954. DISTRIBUTION CURVES FOR LOESS. *Amer. J. Sci.* 252: 99-105, illus.
- (63) SMITH, G. D.
1942. ILLINOIS LOESS-VARIATIONS IN ITS PROPERTIES AND DISTRIBUTION: A PEDOLOGIC INTERPRETATION. III. *Agr. Expt. Sta. Bull.* 490: 139-184, illus.
- (64) ——— and RIECKEN, F. F.
1947. THE IOWAN DRIFT BORDER OF NORTHWESTERN IOWA. *Amer. J. Sci.* 245: 706-713, illus.
- (65) ———, ALLAWAY, W. H., and RIECKEN, F. F.
1950. PRAIRIE SOILS OF THE UPPER MISSISSIPPI VALLEY. *In Advances in Agron.* II, 157-205, illus. Academic Press, Inc., New York.
- (66) SNELL, F. D., and SNELL, C. T.
1949. COLORIMETRIC METHODS OF ANALYSIS. Vol. 2, Ed. 3. Van Nostrand Co. Inc., New York.
- (67) SOIL SURVEY STAFF.
1951. SOIL SURVEY MANUAL. U.S. Dept. Agr. Hdbk 18, 503 pp., illus.
- (68) SUESS, H. E.
1954. U.S. GEOLOGICAL SURVEY RADIOCARBON DATES I. *Sci.* 120: 467-473.
- (69) TATOR, B. A.
1953. PEDIMENT CHARACTERISTICS AND TERMINOLOGY. *Assoc. Amer. Geog. Annals* 43: 47-53.
- (70) THORNBURY, W. D.
1954. PRINCIPLES OF GEOMORPHOLOGY. 618 pp., illus. John Wiley and Sons, New York.
- (71) THORP, J., and SMITH, G. D.
1949. HIGHER CATEGORIES OF SOIL CLASSIFICATION: order, suborder, and great soil group. *Soil Sci.* 67: 117-126.
- (72) ———, JOHNSON, W. M., and REED, E. C.
1951. SOME POST-PLIOCENE BURIED SOILS OF CENTRAL UNITED STATES. *J. Soil Sci.* 2: 1-19, illus.
- (73) ULRICH, R.
1950. SOME PHYSICAL CHANGES ACCOMPANYING PRAIRIE, WIESENBOEDEN, AND PLANOSOL SOIL PROFILE DEVELOPMENT FROM PEORIAN LOESS IN SOUTHWESTERN IOWA. *Soil Sci. Soc. Amer. Proc.* 14: 287-295, illus.
- (74) ———
1951. SOME CHEMICAL CHANGES ACCOMPANYING PROFILE FORMATION OF THE NEARLY LEVEL SOILS DEVELOPED FROM PEORIAN LOESS IN SOUTHWESTERN IOWA. *Soil Sci. Soc. Amer. Proc.* 15: 324-329, illus.

- (75) WARREN, C. R.
1952. PROBABLE ILLINOIAN AGE OF PART OF THE MISSOURI RIVER, SOUTH DAKOTA. Geol. Soc. Amer. Bull. 63: 1143-1156, illus.
- (76) WHITE, E. M., and RIECKEN, F. F.
1955. BRUNIZEM-GRAY BROWN PODZOLIC SOIL BIOSEQUENCES. Soil Sci. Soc. Amer. Proc. 19: 504-509, illus.
- (77) WHITESIDE, E. P., et al.
1954. PROGRESS REPORT OF COMMITTEE ON SOIL HORIZONS. Natl. Tech. Work-Plan. Conf. Coop. Soil Survey. (Mimeo.)
- (78) ———, et al.
1956. PROGRESS REPORT OF COMMITTEE ON SOIL HORIZONS. Natl. Tech. Work-Plan. Conf. Coop. Soil Survey. (Mimeo.)

Appendix

Descriptions of soil mapping units that were discussed but not described in the body of the report follow.

Unit 11A, Sharpsburg silty clay loam, moderately shallow to till (pl. V: D.O., 3.29); Slope 6 percent; cultivated field.

A _p 0-4 inches	Very dark brown (10YR 2/2) medium silty clay loam; weak fine granular structure; friable; Tazewell loess; clear boundary.
B ₂ 4-20 inches	Dark brown (10YR 4/3) medium silty clay loam; weak fine subangular blocky structure; thin discontinuous clay skins in pores and on ped exteriors; gradual boundary.
B ₃₁ 20-34 inches	Dark yellowish brown (10YR 4/4) light silty clay loam; few fine grayer and browner mottles; weak medium blocky structure; friable; base of Tazewell loess; abrupt boundary.
11B ₃₂ 34-40 inches	Dark brown (10YR 4/3) clay loam; few grayish brown (2.5Y 5/2) mottles; weak medium structure; firm; Kansan till; clear boundary.
11C ₂ 40+ inches	Dark grayish brown (10YR 4/2) clay loam; many grayish brown and strong brown (2.5Y 5/2 and 7.5YR 5/6) mottles; massive; firm; calcareous.

Unit 11B, Sharpsburg silty clay loam, moderately shallow to Yarmouth-Sangamon paleosol (pl. V: I.22, 5.7); Slope 6 percent, convex; cultivated field.

A _{1p} 0-8 inches	Very dark gray (10YR 3/1) medium silty clay loam; moderate fine granular structure; friable; leached Tazewell loess; gradual boundary.
AB 8-14 inches	Very dark grayish brown (10YR 3/2) medium silty clay loam; weak medium subangular blocky structure; gradual boundary.
B ₂ 14-24 inches	Dark grayish brown (10YR 4/2) medium silty clay loam; few strong brown (7.5YR 5/6) mottles; weak fine subangular blocky structure; thin continuous clay skins; friable; base of Tazewell loess; abrupt boundary.
11B ₂₁ 24+ inches	Olive gray (5Y 5/2) clay; few strong brown (7.5YR 5/6) mottles; weak fine subangular blocky structure; thick continuous clay skins coat ped exteriors; firm; Kansan till; B ₂ horizon of Yarmouth-Sangamon paleosol.

Unit 11C, Sharpsburg silty clay loam, moderately shallow to late Sangamon paleosol (pl. V: E.42, 3.7); Slope 8 percent; cultivated field.

A _{1p} 0-10 inches	Very dark brown (10YR 2/2) light silty clay loam; weak fine granular structure; friable; Tazewell loess; clear boundary.
AB 10-18 inches	Very dark grayish brown (10YR 3/2) medium silty clay loam; weak fine subangular blocky structure; friable; gradual boundary.
B ₂ 18-28 inches	Dark brown (10YR 4/3) medium silty clay loam; weak fine subangular blocky structure; thin continuous clay skins coat ped exteriors; friable; base of Tazewell loess; abrupt boundary.
11A ₂₁ 28-40 inches	Dark brown (10YR 4/3) medium gritty silt loam; weak medium blocky structure; friable; late Sangamon pedisegment; gradual boundary.
11B ₁₁ 40-48 inches	Dark brown (10YR 4/3) clay loam; few grayer and browner mottles; weak fine or medium subangular blocky structure firm; stone line in base; base of late Sangamon pedisegment.
111B ₂₁₁ 48-66 inches	Dark grayish brown (10YR 4/2) clay; few grayer and browner mottles; weak fine subangular blocky structure; thick continuous clay skins; firm; leached Kansan till.

Unit 22, Shelby loam, sandy subsoil variant (pl. V: G.35, 4.47): Slope 15 percent; bluegrass.

- A₁ 0-14 inches Very dark brown (10YR 2/2) loam; very weak, almost single grain, granular structure; very friable; Kansan till; gradual boundary.
- B₂ 14-30 inches Dark yellowish brown (10YR 4/4) sandy loam; very weak medium or coarse blocky structure that breaks to single grain; very friable; gradual boundary.
- C₁ 30+ inches Yellowish red (5YR 5/8) fine sandy loam; single grain structure.

Unit 24, Steinauer clay loam (pl. V: H.29, 4.26): Slope 18 percent; cultivated field.

- A₁ 0-6 inches Very dark grayish brown (10YR 3/2) light clay loam; weak fine granular structure; friable; calcareous Kansan till; clear boundary.
- C 6+ inches Brown (10YR 5/3) light clay loam; few fine reddish brown (5YR 4/4) mottles; massive; friable; calcareous.

In areas where the late Sangamon surface is adjacent to the Yarmouth-Sangamon surface, the paleosols have characteristics common to both. These paleosols are classified as the Adair-Clarinda intergrade (fig. 68: 35). A soil of this kind developed in Kansan till (pl. V: D.6, 3.8) is:

- A_{1p} 0-4 inches Very dark grayish brown (10YR 3/2) heavy silt loam; weak fine granular; friable; clear boundary.
- A₁₂ 4-10 inches Very dark grayish brown (10YR 3/2) light silty clay loam; weak fine subangular blocky structure; friable; leached Kansan till; gradual boundary.
- PA₂ 10-20 inches Dark brown (10YR 4/3) heavy silt loam; weak fine subangular blocky structure; patchy, white to light gray silt coats; friable; clear boundary.
- PB₁ 20-26 inches Dark grayish brown (2.5Y 4/2) medium clay loam; moderate fine subangular blocky structure; thin continuous clay skins; common patchy white silt coats; firm; weatherable minerals visible; clear boundary.
- PB₂ 26-36 inches Olive gray (5Y 4/2) clay; few fine strong brown and yellowish red mottles; moderate fine subangular blocky structure; thick continuous clay skins; firm; weatherable minerals visible; gradual boundary.
- PB₃ 36-48 inches Olive gray (5Y 4/2) heavy clay loam; weak medium subangular blocky structure; thin continuous clay skins; firm; abundant weatherable minerals; gradual boundary.
- PC₁ 48+ inches Variegated olive gray, grayish brown and brown (5Y 4/2, 2.5Y 5/2, and 10YR 5/3) medium light clay loam; massive; firm.

The following soils were discussed but not described in the body of the report. Thin-section descriptions follow the profile descriptions.

Profile B, unit 12, Sharpsburg silty clay loam: Slope 9 percent convex; cultivated field

Collected by: R. B. Daniels and F. J. Carlisle, 11/5/55.

Location: SW $\frac{1}{4}$ NW $\frac{1}{4}$ SW $\frac{1}{4}$ sec. 17, T. 76 N., R. 31 W., Adair County, Iowa.

- A_{1p} 0-7 inches Black (10YR 2/1) light silty clay loam; cloddy breaking to fine granular; friable; Tazewell loess; clear boundary.
- A₁₂ 7-16 inches Black (10YR 2/1) light to medium silty clay loam; weak fine and medium granular; friable; gradual boundary.
- A₃ 16-19 inches Black (10YR 2/1) light to medium silty clay loam; few very dark grayish brown (10YR 3/2) mottles; weak to moderate fine subangular blocky structure; friable; gradual boundary.
- B₂₁ 19-25 inches Very dark grayish brown (10YR 3/2) medium to heavy silty clay loam; few very dark gray (10YR 3/1) areas; weak fine subangular blocky structure continuous thin clay skins; friable; gradual boundary.
- B₂₂ 25-33 inches Dark grayish brown (10YR 4/2) medium to heavy silty clay loam; few very dark brown (10YR 2/2) mottles; few fine faint grayer and browner mottles in the lower part; moderate fine subangular blocky structure; thin continuous clay skins; slightly firm; gradual boundary.

- B₁ 33-46 inches Dark grayish brown (10YR 4/2) medium silty clay loam; many distinct grayish brown (2.5Y 5/2) and strong brown to brown mottles; weak to moderate medium blocky structure; thin continuous clay skins coat larger aggregates; aggregates form weak medium to coarse prisms; slightly firm; gradual boundary.
- C₁ 46-72 inches Variegated grayish brown (2.5Y 5/2) and strong brown to dark brown light silty clay loam; common fine dark oxide accumulations; massive; thin to medium clay skins on vertical faces of cleavage planes; friable.

Profile E, unit 11, Sharpsburg silty clay loam: Slope 2 percent, convex; cultivated field.

Collected by: R. B. Daniels and F. J. Carlisle, 11/5/55.

Location: NE corner SE $\frac{1}{4}$ NE $\frac{1}{4}$ SE $\frac{1}{4}$ sec. 18, T.76 N., R.31 W., Adair County, Iowa.

- A_{1P} 0-6 inches Very dark brown (10YR 2/2) light silty clay loam; cloddy breaking to fine granular; friable; Tazewell loess; clear boundary.
- A₁₂ 6-12 inches Very dark brown (10YR 2/2) light to medium silty clay loam; weak medium granular structure; friable; gradual boundary.
- AB 12-15 inches Very dark brown (10YR 2/2) medium silty clay loam; few dark brown (10YR 4/3) mottles; moderate fine subangular blocky structure; friable; gradual boundary.
- B₂₁ 15-19 inches Dark brown (10YR 4/3) medium to heavy silty clay loam with approximately 25 percent very dark grayish brown and very dark gray (10YR 3/2 and 3/1); moderate fine subangular blocky structure; thin continuous clay skins; moderately friable; gradual boundary.
- B₂₂ 19-30 inches Dark brown (10YR 4/3) heavy silty clay loam; few fine faint mottles in the lower 3 inches; moderate fine subangular blocky structure; thin continuous clay skins; firm; gradual boundary.
- B₃ 30-43 inches Dark brown (10YR 4/3) grading with depth to dark grayish brown (10YR 4/2) light to medium silty clay loam; common fine grayish brown (2.5Y 5/2) and strong brown mottles; moderate to strong (dry) medium blocky structure; firm; gradual to diffuse boundary.
- C₁ 43-72 inches Variegated yellowish brown and grayish brown (10YR 5/4) and 2.5Y 5/2 heavy silt loam to light silty clay loam; common very fine dark oxides; massive; thin continuous clay skins on vertical cleavage faces to a depth of about 50 inches; friable.

Profile G, unit 11, Sharpsburg silty clay loam: Slope 9 percent, convex; cultivated field.

Collected by: R. B. Daniels, 8/28/56.

Location: 420 feet north and 162 feet west of SW corner of SW $\frac{1}{4}$ SW $\frac{1}{4}$ sec. 17, T.76 N., R.31 W., Adair County, Iowa.

- A_{1P} 0-5 inches Very dark brown (10YR 2/2) medium to heavy silty clay loam; very dark brown (10YR 2/2) crushed and dark grayish brown (10YR 4/2) dry; cloddy breaking to weak fine granular; friable; Tazewell loess; clear boundary.
- AB 5-9 inches Very dark grayish brown (10YR 3/2) heavy silty clay loam; few very dark brown and dark brown (10YR 2/2 and 4/3) mottles; very dark grayish brown (10YR 3/2) crushed and grayish brown (10YR 5/2) dry; weak fine subangular blocky structure; thin continuous coat; friable; clear boundary.
- B₂ 9-22 inches Dark brown (10YR 4/3) heavy silty clay loam with few very dark grayish brown (10YR 3/2) areas in the upper part; dark brown (10YR 4/3) crushed and brown (10YR 5/3) dry; weak fine subangular blocky structure; thin continuous clay skins; friable; gradual boundary.
- B₃ 22-37 inches Dark grayish brown (10YR 4/2) medium silty clay loam; few to common fine grayish brown (2.5Y 5/2) mottles; dark yellowish brown (10YR 4/4) crushed and pale brown (10YR 6/3) dry; weak medium blocky structure; thin continuous clay skins in upper part becoming discontinuous on horizontal surfaces in the lower part of the horizon; friable; gradual boundary.

C 37-51 inches Brown (10YR 5/3) light silty clay loam; common fine and medium grayish brown (2.5Y 5/2) mottles; few to common fine dark brown and strong brown (7.5YR 4/4 and 5/6) mottles yellowish brown (10YR 5/4) crushed; variegated pale brown (10YR 6/3) and light brownish gray (2.5Y 6/2) and reddish yellow (7.5YR 7/6) dry; massive; thin continuous clay skins on vertical cleavage faces.

Profile G, unit 11, thin-section description:

AB 5-8 inches This horizon appears to contain more clay than B₂ and C₁. Structure is similar to B₂ but there are some pronounced differences. Much of the clay is in silt-size oriented flakes and skins on particles. Continuous zones, bands, and patches of segregated pressure-oriented clay extend for several millimeters. The most prominent feature is a stacked-ball structure. These round aggregates are seldom discrete but appear in plain light as variations in density. The smallest ones are slightly larger than the largest primary grains; the largest almost 1 cm. across. They seem to have oriented skins or orientation of clay parallel to the circumference, visible in crossed polarized light. Crevices, channels, or ped faces are generally lined with an extremely thin coat of oriented clay. Coats are about as common as in the B horizon as seen in sections but are thinner. No bands of oriented clay were seen within the matrix close to the partings. Concretions are present as in the B.

B₂ 10-13 inches Clay in the average matrix or interior of peds is in silt-size oriented flakes and oriented skins around primary mineral grains as in the C horizon. Orientation seems to be such that the flakes give the effect of a diffuse continuous angular network. This effect is due to pressure as a result of shrinkage and swelling. Most of the primary grains have pressure-oriented coats. Clay concentration varies greatly. There are local patches of high concentration and some of the small peds or aggregates have more clay than the larger one. Most of the areas of high concentration are near or at surfaces and related to cracks, channels, crevices, or pores. Many of these partings have very thin films or oriented clay along them which might be identifiable in the field. The prevalence of layered concentrations of oriented clay parallel to and close to surfaces may have several interpretations. This clay may have been at the surface as a skin and pulled back in when the specimen was dried; it may have moved out from the interior of the ped; or it may indicate that the peds do not have fixed definite surfaces but can break in several possible places. Dense mottles or concretions are common. These are almost opaque but in places where section is very thin their internal structure can be seen. They are probably formed from mottles in the C. Clay and possibly goethite is well oriented. Some concretions are possibly breaking down for there is a zone around some having high iron-stained clay content. Some concretions have coats of lighter colored oriented clay.

C₁ 41-44 inches This sample has variable structure from place to place. The clay in pale grayish and buff areas is a rough random reticulate pattern among the primary mineral grains. Most of these grains have a coat of oriented clay. There are silt-size aggregates of oriented clay with rather high birefringence which are probably weathered mica. Some elements of the reticulate oriented pattern are larger than the primary mineral grain size indicating that there has been some adjustment to position of the clay, possibly by pressure, but in the general matrix there are no bodies of clay larger than the other grains. Clay skins and other evidence of clay movement are common. Many of the pores, channels, and cracks are lined with films of pure oriented clay. Red mottles are higher in clay than the matrix, and most of this clay shows evidence of movement with orientation. The clay is red and shows higher birefringence due either to better orientation or to the iron content. Some micro-crystalline material in the red mottles appears to be goethite.

Profile I, unit 21A, Shelby clay loam, deep to carbonate phase: Slope 15 percent, convex; cultivated field.

Collected by: R. B. Daniels and G. H. Simonson, 7/31/56.

Location: 279 feet east and 129 feet south of NW corner of SW $\frac{1}{4}$ SE $\frac{1}{4}$ NW $\frac{1}{4}$ sec. 18, T.76 N., R.31 W., Adair County, Iowa.

A _{1P} 0-7 inches	Very dark brown (10YR 2/2) light silty clay loam to light clay loam; very dark brown (10YR 2/2) crushed and dark gray (10YR 4/1) dry; weak fine granular structure; friable; Kansan till; clear boundary.
AB 7-11 inches	Very dark grayish brown (10YR 3/2) medium silty clay loam to clay loam; few very dark brown and dark brown (10YR 2/2 and 4/3) mottles; very dark grayish brown (10YR 3/2) crushed and dark gray to dark grayish brown (10YR 4/1 and 4/2) dry; moderate fine subangular blocky structure; slightly firm; clear boundary.
B ₂₁ 11-17 inches	Dark brown (10YR 4/3) medium clay loam; few very dark brown (10YR 2/2) areas along channels; moderate fine and very fine subangular blocky structure; thin continuous clay skins; firm; clear boundary.
B ₂₂ 17-23 inches	Dark yellowish brown (10YR 4/4) heavy clay loam; few very dark brown (10YR 2/2) areas along channels; weak to moderate fine subangular blocky structure; medium continuous clay skins; firm; clear boundary.
B ₃₁ 23-34 inches	Dark brown (10YR 4/3) medium clay loam; few fine faint grayer and few coarse strong brown and reddish yellow (7.5YR 5/6 and 6/8) mottles; weak fine and medium blocky structure; thin to medium continuous clay skins; very firm; gradual boundary.
B ₃₂ 34-48 inches	Dark brown (10YR 4/3) medium clay loam; common medium grayish brown (2.5Y 5/2) and few fine strong brown mottles; weak to very weak medium to coarse blocky structure; medium clay skins on vertical surfaces of weak medium prisms; thin continuous clay skins on blocky peds becoming discontinuous in the lower part; clear boundary.
C ₂₁ 48-60 inches	Variegated grayish brown and dark yellowish brown (2.5Y 5/2 and 10YR 4/4) light clay loam; massive; thin discontinuous clay skins on vertical cleavage planes; very firm; calcareous Kansan till; common white soft to very hard carbonate concretions < 1/4 inch in diameter; gradual boundary.
C ₂₂ 60-72 inches	Variegated grayish brown and yellowish brown (2.5Y 5/2 and 10YR 5/6) sandy loam; massive; friable; calcareous; gradual boundary.
C ₂₃ 72-82 inches	Yellowish brown (10YR 5/4) light clay loam; common medium grayish brown (2.5Y 5/2) and few fine strong brown mottles; massive; firm; calcareous.

Profile K, unit 21, Shelby clay loam, moderately shallow to carbonate phase: Slope 12 percent, convex; bluegrass.

Collected by: R. B. Daniels and J. A. Phillips, 8/1/56.

Location: 412 feet east and 33 feet north of SW corner of SW 1/4 SW 1/4 NE 1/4 sec. 18, T.76 N., R.31 W., Adair County, Iowa.

A ₁ 0-9 inches	Very dark brown (10YR 2/2) medium clay loam; very dark brown (10YR 2/2) crushed; moderate fine and very fine subangular blocky structure; friable; Kansan till; clear boundary.
AB 9-14 inches	Very dark grayish brown (10YR 3/2) medium to heavy clay loam; few very dark brown (10YR 2/2) areas along vertical channels; few dark brown (10YR 4/3) mottles; dark grayish brown (10YR 4/2) crushed; moderate fine and very fine subangular blocky structure; discontinuous coat on ped surfaces; friable; clear boundary.
B ₂₁ 14-22 inches	Dark brown (10YR 4/3) medium clay loam; few very dark grayish brown (10YR 3/2) areas along vertical channels; dark brown (10YR 4/3) crushed; moderate to strong fine subangular blocky structure; thin continuous clay skins; slightly firm; clear boundary.
B ₂₂ 22-29 inches	Dark brown (10YR 4/3) medium clay loam; yellowish brown (10YR 5/4) crushed; weak to moderate fine subangular blocky structure; thin to medium continuous clay skins; firm; few white carbonate concretions 1/4 inch in diameter in the lower part, but the matrix is leached. The depth to the lower boundary of the B ₂₂ horizon across the sampling areas is 29 to 32 inches. Abrupt boundary.
B ₂₃ 29-37 inches	Dark yellowish brown (10YR 4/4) medium clay loam; common medium to coarse yellowish red (5YR 4/6) and common fine strong brown (7.5YR 5/6) mottles; strong brown (7.5YR 5/8) crushed; weak fine and medium subangular blocky structure; thin continuous clay skins; slightly firm; calcareous Kansan till; common white firm to very firm carbonate concretions < 1/4 inch in diameter; clear boundary.

- B₁** Yellowish brown (10YR 5/6) medium clay loam; few medium and coarse gray (5Y 5/1) and few fine strong brown mottles; weak medium blocky structure; thin discontinuous clay skins on horizontal surfaces and thin continuous clay skins on vertical surfaces; firm; calcareous; few white firm to very firm carbonate concretions and limestone fragments < 1/4 inch in diameter; abrupt boundary.
- C₂₁** Yellowish brown (10YR 5/4) sandy loam; common fine to medium strong brown (7.5YR 5/6) mottles; massive; very friable; calcareous; few white firm to very firm carbonate concretions and limestone fragments < 1/4 inch in diameter; abrupt boundary.
- C₂₂** Grayish brown to brown (10YR 5/2 to 5/3) light clay; common, medium and coarse, strong brown and (7.5YR 5/6) yellowish red (5YR 5/8) mottles; common medium to fine gray (5Y 5/1) mottles; few to common dark oxide coats; massive; firm; calcareous; few white firm to very firm carbonate concretions < 1/2 inch in diameter.

Profile K, unit 21, thin-section description:

AB This is like the B in having bands and stringers of clay with parallel orientation and skins around grains. On the whole there is much evidence of organization, rearrangement, and orientation of clay. In some areas most of the clay appears to be in small randomly arranged chips and flakes, much smaller than most of the primary grains. Some (fewer than 1/3) of the channels, ped faces, and pores have thin oriented clay coats and there is some tendency for concentrations of oriented clay to occur within the matrix parallel to walls of openings. Clay has probably been stripped from most of the surfaces and moved to the B horizon.

B₂₂ The clay in this specimen shows considerably more organization than any horizon studied from unit 11 or unit 23. Clay content appears high but perhaps this impression is a result of the better organization of clay that makes it more visible. Clay is in oriented flakes, up to the sand size. There are also some larger stringers and aggregates. Many or most of the medium and large grains have a conspicuous but thin skin of oriented clay. There is some variation in clay concentration from place to place over distances of millimeters, such as irregular balls and patches with higher clay content and more oriented clay. Much of the oriented flake and network area has a rough rectangular parallel arrangement, possibly the result of shear or compression. Clay skins are common and thicker than in unit 11 and unit 23. Almost all pores, aggregate faces, and channels have an oriented clay coat. Besides the coat there is often a concentration of oriented clay in the matrix near pore and channel walls. Some of the stringers of oriented clay within the matrix in both horizons are probably former ped-face surfaces which closed up or weakly developed ped faces.

Profile M, unit 23, Shelby-Steinauer intergrade: Slope 6 percent, convex; bluegrass and timothy pasture.

Collected by: R. B. Daniels, 7/17/56.

Location: 180 feet west and 56 feet south of NE corner of SW 1/4 NE 1/4 SE 1/4 sec. 18, T.76 N., R.31 W., Adair County, Iowa.

- A₁** Very dark brown (10YR 2/2) light to medium clay loam; weak to moderate fine and very fine granular structure; friable; Kansan till; clear boundary.
- AB** Very dark grayish brown (10YR 3/2) medium clay loam with few very dark brown and dark brown (10YR 2/2 and 4/3) areas; weak to moderate fine granular structure; slightly firm; clear boundary.
- B₂** Dark brown (10YR 4/3) medium clay loam; moderate to strong fine subangular blocky structure; medium continuous clay skins; slightly firm; calcareous Kansan till; few to common loose to extremely hard limestone fragments and carbonate concretions ranging in diameter from < 1/8 to 3/4 inches; gradual boundary.
- B₂₁** Dark yellowish brown (10YR 4/4) medium clay loam; common gray (5Y 5/1) streaks up to 4 inches long and < 1/4 inch wide; weak medium blocky structure; thin continuous clay skins; firm; calcareous; common loose to extremely hard limestone fragments and carbonate concretions < 1/2 to 1 inch in diameter; gradual boundary.

- B₂₁** Dark brown to brown (10YR 4/3 to 5/3) medium to light clay loam; common gray (5Y 5/1) streaks; weak medium blocky structure; thin continuous clay skins becoming discontinuous in the lower part of the horizon; firm; calcareous; few to common loose to extremely hard limestone fragments and carbonate concretions; diffuse boundary.
- 29-43 inches
- C** Brown (10YR 5/3) light clay loam; common fine to coarse dark brown and strong brown (7.5Y 4/4 and 5/6) mottles; common gray (5Y 5/1) streaks; massive; thin discontinuous clay skins along vertical cleavage planes; firm; calcareous; few to common loose to very hard < 1/8 to 3/4 inch carbonate concretions.
- 43-60 inches

Profile L, unit 23, thin-section description:

- AB** There are common roughly ball-shaped structures with oriented clay roughly parallel to their circumference and also numerous sand and silt particles have oriented skins. Most aggregate surfaces have no coats though a few small patchy coats were seen and some surfaces were lined with extremely thin films. There are a few round pores with clay film linings and an abundance of interior stringers and patches of dark brown oriented clay, probably old clay skins on formerly void walls. Clay concentration seems to be somewhat varied or at least the amount of organization or aggregate orientation is varied so that the clay is more visible in some places than others. Some of the outer surfaces of aggregates appear to contain less clay than the interior, suggesting that clay has been stripped away.
- 6-9 inches
- B₂₁** This is considerably different from C₁ and B₂₁. Calcite is gone and there has been much rearrangement of clay into oriented networks. Commonly over a distance of several millimeters clay will tend to have parallel orientation in one or two directions because of pressure. There are many clay balls and skins around grains. Clay is a darker brown than in the horizons below. Thin clay films are common on most aggregate surfaces, and some are thick enough to be called clay skins; they are well oriented and free from coarser particles. One has the impression that ped surfaces are not stable, but breakage occurs in different places at different times as there are stringers of oriented clay running through the section where there is now no sign of a break or surface.
- 10-13 inches
- B₂₁** This is calcareous but lime concentration is not as high as in the C. In a few spots lime has been removed, but in general it is much like the C. There is some evidence of rearrangement of clay due to slumping after removal of some carbonates; most of it resembles the brown parts of the C specimen. Faces of some peds or cleavage surfaces have a very thin coat of poorly oriented clay and there is often a concentration of clay near the walls of such crevices. Such a concentration also may be due to leaching. Many of the crevices are lined with a film of very small calcite crystals and occasionally a channel is filled with recrystallized calcite. One section shows a large area (1 cm.) in which clay flows are common. This area is lower in calcite than some of the rest but not free from it. In one place a definite, but thin, oriented film of clay in a channel runs along the face of a limestone fragment. Some of the clay that has apparently moved is mixed with calcite. Calcite moves and reprecipitates so possibly it and the clay moved at different times.
- 22-25 inches
- C** The specimens are quite heterogeneous in detail. The most conspicuous feature is the large scale mottling and segregation of brown and gray areas. Gray areas appear lower in clay and higher in carbonate than brown ones. The higher clay content of brown patches may be due to some local concentration by leaching of carbonate. Clay in gray spots is in small random chips but in brown spots it seems to be more organized into larger flakes and bands. In general there is no evidence of much clay movement, but there are a few features that look like old clay skins now crushed and distorted. Some banding and orientation of large grains and clay appears to be caused by pressure. The cleavage surfaces generally are rather smooth and some have some kind of fine grained coat. Occasionally patches or oriented clay are present, possibly a slickenside effect, but the commonest coat is a fine-grained dust of CaCO₃, possibly mixed with clay.
- 35-38 inches

Profile O, unit 51, Arbor silt loam: Slope 14 percent, concave; cultivated field.

Collected by: R. B. Daniels, F. J. Carlisle, G. H. Simonson, 7/26/56.

Location: 490 feet east and 100 feet south of NW corner of NW¹/₄, SE¹/₄, NW¹/₄ sec. 18, T.76 N., R.31 W., Adair County, Iowa.

A _{1p} 0-6 inches	Very dark brown (10YR 2/2) heavy loam; very dark brown (10YR 2/2) crushed and dark grayish brown (10YR 4/2) dry; cloddy breaking to weak fine granular; very friable valley-side alluvium; clear boundary.
A _{1t} 6-12 inches	Very dark brown (10YR 2/2) heavy loam; very dark grayish brown (10YR 3/2) crushed and dark grayish brown (10YR 4/2) dry; weak fine and very fine granular structure; very friable; clear boundary.
AB 12-16 inches	Very dark grayish brown (10YR 3/2) heavy loam to light clay loam; few very dark brown (10YR 2/2) areas along channels; dark grayish brown (10YR 4/2) crushed and brown (10YR 5/3) dry; weak to moderate fine and very fine subangular blocky structure; very friable; clear boundary.
B ₂₁ 16-21 inches	Dark brown (10YR 4/3) light clay loam; few very dark brown and very dark grayish brown (10YR 2/2 and 3/2) areas along vertical channels; dark brown (10YR 4/3) crushed and brown (10YR 5/3) dry; weak fine subangular blocky structure; thin discontinuous coats; friable; base of valley-side alluvium; abrupt boundary.
B ₂₂ 21-23 inches (stone line)	Dark brown (10YR 4/3) light clay loam; few very dark grayish brown (10YR 3/2) areas along vertical channels; weak fine subangular blocky structure; thin discontinuous coats; friable; gravel ranges from 2 mm. to 175 mm. but is dominantly less than 50 mm. in diameter; abrupt boundary.
IB _{2a} 23-30 inches	Dark brown to brown (10YR 4/3 to 5/3) medium clay loam; dark yellowish brown (10YR 4/4) crushed and yellowish brown (10YR 5/4) dry; weak fine subangular blocky structure; thin discontinuous clay skins; friable; Kansan till; clear boundary.
IB _{2b} 30-40 inches	Dark yellowish brown (10YR 4/4) light clay loam; common to fine to medium, faint to distinct grayish brown (2.5Y 5/2) and strong brown (7.5YR 5/6) mottles arranged in indistinct horizontal bands; weak medium blocky structure; slightly firm; gradual boundary.
IB _{2c} 40-50 inches	Dark brown (10YR 4/3) light clay loam; few fine distinct strong brown to dark brown and grayish brown (2.5Y 5/2) mottles; distinct strong brown (7.5YR 5/6) grading to dark brown (7.5YR 4/4) horizontal bands ¹ / ₄ to 1 ¹ / ₂ inches wide; very weak medium to coarse blocky structure; few coats; slightly firm; clear boundary.
11C 50-61 inches	Dark brown (10YR 4/3) light clay loam; many medium distinct light olive gray (5Y 6/2) and dark yellowish brown to strong brown mottles; massive; firm; calcareous Kansan till; common white carbonate concretions < ¹ / ₄ inch in diameter; abrupt boundary.
D ₁ 61-65 inches	Gray to light olive gray (5Y 6/1 to 6/2) sandy clay loam; massive; friable; calcareous; gradual boundary.
D ₂ 65-88 inches	Stratified yellowish brown to grayish brown (10YR 5/4 to 5/2) medium to coarse sands; calcareous; clear boundary.
D ₃ 88+ inches	Gray to light olive gray (5Y 6/1 to 6/2) light clay loam to sandy clay loam; calcareous.

Profile O, unit 51, thin-section description:

B ₂₁ 16-19 inches	The morphology of this horizon is between that of the B ₂₂ of the other sediment and the till materials. Clay is in small stringers, chips, and bands. These are larger and stringers and bands are continuous over greater distances than in the B ₂₂ of unit 53. There are numerous ball-like structures with oriented film surfaces and oriented skins on most of the sand and silt grains. There are concentrations of oriented clay in the matrix near many of the pores, channels, and other surfaces, and thin clay skins on void walls.
---------------------------------	---

IIB₂₁ This horizon is very dense; there are few pores, crevices, ped faces, or other open surfaces. There is much variety in arrangement and concentration of clay. Aggregates of clay in the form of chips and flakes are general. Large areas appear packed with clay in rather large bands and stringers with parallel orientation. Generally, and especially in large areas, sand and coarse silt grains have thick coats of oriented clay. Pressure orientation of clay flakes and stringers into a parallel boxlike network is common. Thin but continuous clay skins were observed in the few openings present. It is probable that some of the stringers and bands of oriented clay are clay skins between structural units that are not separated. Clay is bright brown and has high birefringence as if the free iron oxide content might be high.

Profile Q, unit 53, Olmitz silty clay loam: Slope 7 percent, concave; cultivated field.

Collected by: R. B. Daniels and G. H. Simonson, 7/30/56.

Location: 210 feet east and 400 feet south of the NW corner of NW $\frac{1}{4}$ NW $\frac{1}{4}$ SE $\frac{1}{4}$ sec. 18, T.76 N., R.31 W., Adair County, Iowa.

- A_{1P}** Black (10YR 2/1) heavy silt loam to light silty clay loam; black (10YR 2/1) crushed and dark gray (10YR 4/1) dry; cloddy breaking to weak fine granular; friable; valley-side alluvium; clear boundary.
- A_{1S}** Black (10YR 2/1) light silty clay loam; black (10YR 2/1) crushed and dark gray (10YR 4/1) dry; moderate fine subangular blocky and very fine granular structure; friable; gradual boundary.
- AB** Very dark brown (10YR 2/2) light to medium silty clay loam; few black and very dark grayish brown (10YR 2/1 and 3/2) mottles; very dark grayish brown (10YR 3/2) crushed and dark gray (10YR 4/1) dry; weak fine subangular blocky structure; thin discontinuous coats; peds are arranged in weak medium prisms; friable; gradual boundary.
- B₂₁** Very dark grayish brown (10YR 3/2) medium clay loam; few very dark brown (10YR 2/2) mottles; very dark grayish brown (10YR 3/2) crushed and dark grayish brown (10YR 4/2) dry; weak fine to medium subangular blocky structure; peds are arranged in weak medium prisms; thin continuous clay skins on prism faces but thin discontinuous clay skins in the interior of the prisms; friable; gradual boundary.
- B₂₂** Dark grayish brown (10YR 4/2) heavy clay loam; yellowish brown (10YR 5/4) ped interiors; weak medium subangular blocky structure; peds are arranged in weak medium prisms; thin continuous clay skins on prism faces but thin discontinuous clay skins on the subangular blocky peds in the interior of the prisms; slightly firm; abrupt boundary.
- B₃** Yellowish brown (10YR 5/4) gravelly medium clay loam; few faint grayish brown (10YR 5/2) mottles; very weak medium blocky structure; thin discontinuous clay skins on vertical surfaces; firm; maximum diameter of gravel is 25 mm.; abrupt boundary.
- D₁** Yellowish brown (10YR 5/6) fine sandy clay loam; common medium, grayish brown (2.5Y 5/2) mottles; massive; abrupt boundary.
- D₂** Stratified clays; sandy clays and sands; colors are olive gray (5Y 5/2) to yellowish brown (10YR 5/6); base of valley-side alluvium; abrupt boundary.
- IID₂** Brown (10YR 5/3) clay loam; firm; calcareous Kansan till. A stone line marks the contact between the valley-side alluvium and Kansan till.

Profile P, unit 53, thin-section description:

- A₁₂** This horizon shows very little clay organized or oriented over any distance. Even the usual small chips and flakes of oriented clay are not conspicuous. The main structure is a stacked-ball arrangement of coarse through fine sand sizes that shows as spots or areas of greater density. A few balls have oriented clay films on or parallel to their surfaces. A few of the large grains of quartz and feldspar have thin inconspicuous surface films. An occasional very thin clay film can be found on a ped surface or in a pore or crevice. The ball structure is very striking, indicating activity of fauna as the main factor in structure of this horizon.

B₂
37-40 inches

This is considerably different from the till-derived materials in profiles K and L. Much or most of the clay is in small oriented flakes and chips. In this sample, however, they are very small and there does not seem to be much of the pressure orientation shown by parallel rectangular or rhombic pattern. Oriented skins on grains and ball-like aggregates with skins are uncommon. But there are good examples of well-developed clay skins and clay flows in some crevices and in many pores. Where present, these are the thickest, purest, and best developed seen in any of the sections, but they do seem most common in pores and isolated pockets rather than on planes, crevices, or ped faces.

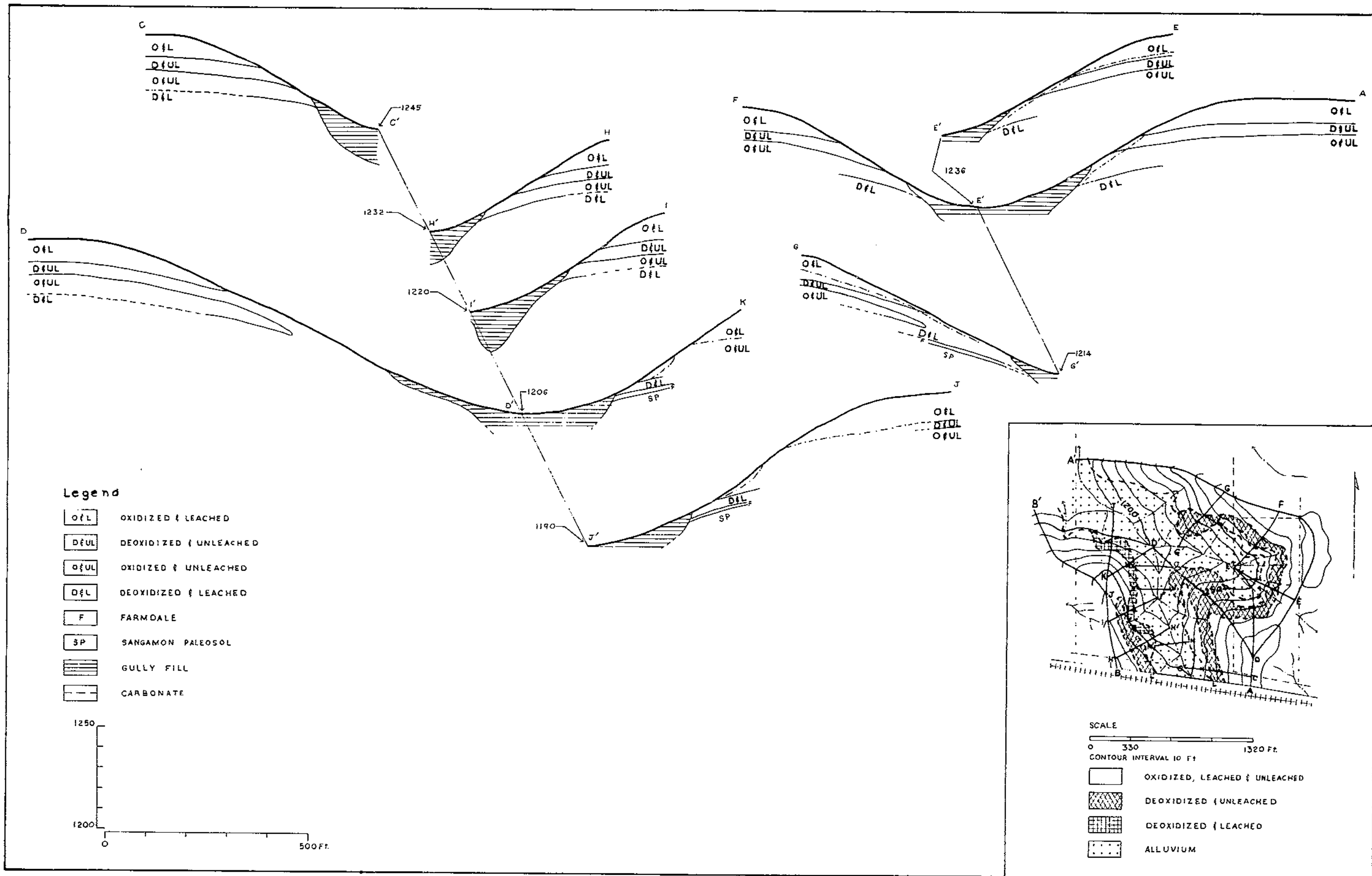
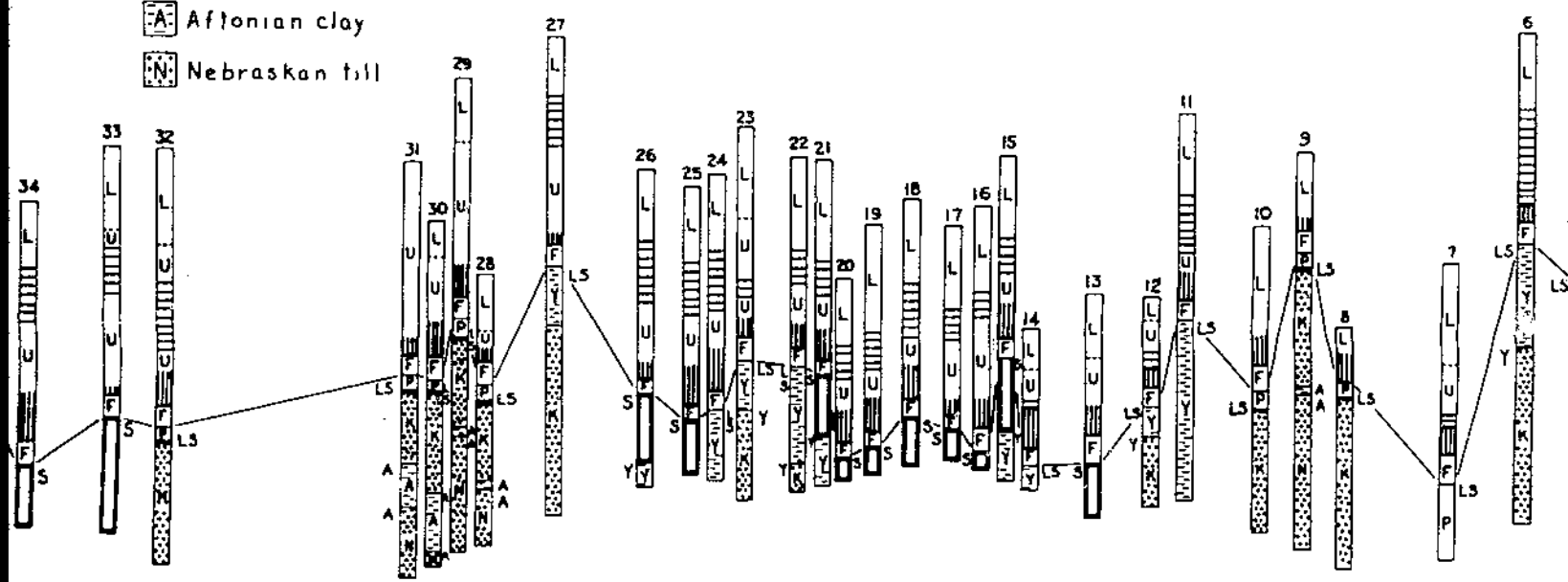

Plate VI. Distribution of weathering zones in Tazewell loess from center of divides to their outcrops on valley slopes.

TB 1548 (1967) USDP TECHNICAL BULLETINS SUPPLEMENTAL DATA
LANDSCAPE EVOLUTION AND SOIL FORMATION IN SOUTHWESTERN IOWA
ROHE, R. V. DANIELS, R. B. CADY, J. G. 4 OF 4

- loess leached [P] Late Sangamon ped-sediment
- leached [] Loveland loess
- unleached [Y] Yarmouth clay
- leached [K] Kansan till
- [A] Afftonian clay
- [N] Nebraskan till

- Paleosols
- LS: Late Sangamon
 - S: Sangamon
 - Y-S: Yarmouth-Sangamon
 - Y: Yarmouth
 - A: Afftonian



profile of traverse

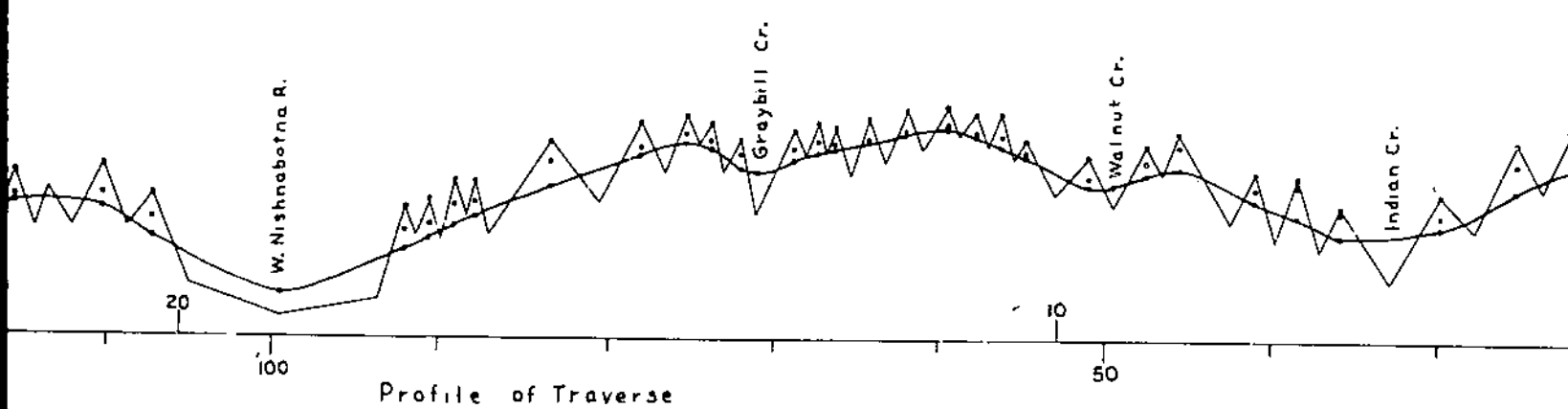

Profile of Traverse

LANDSCAPE EV

— Gap of 21 miles —

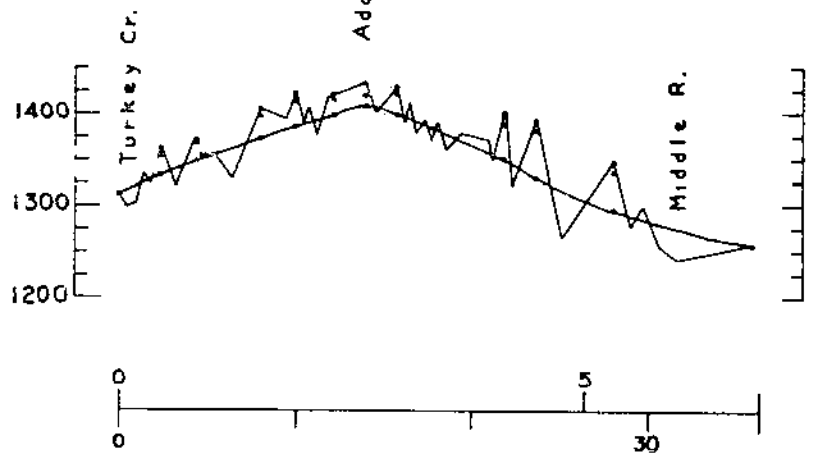
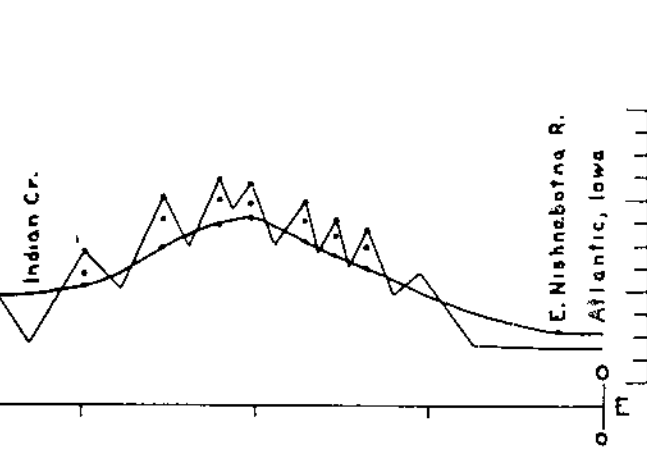
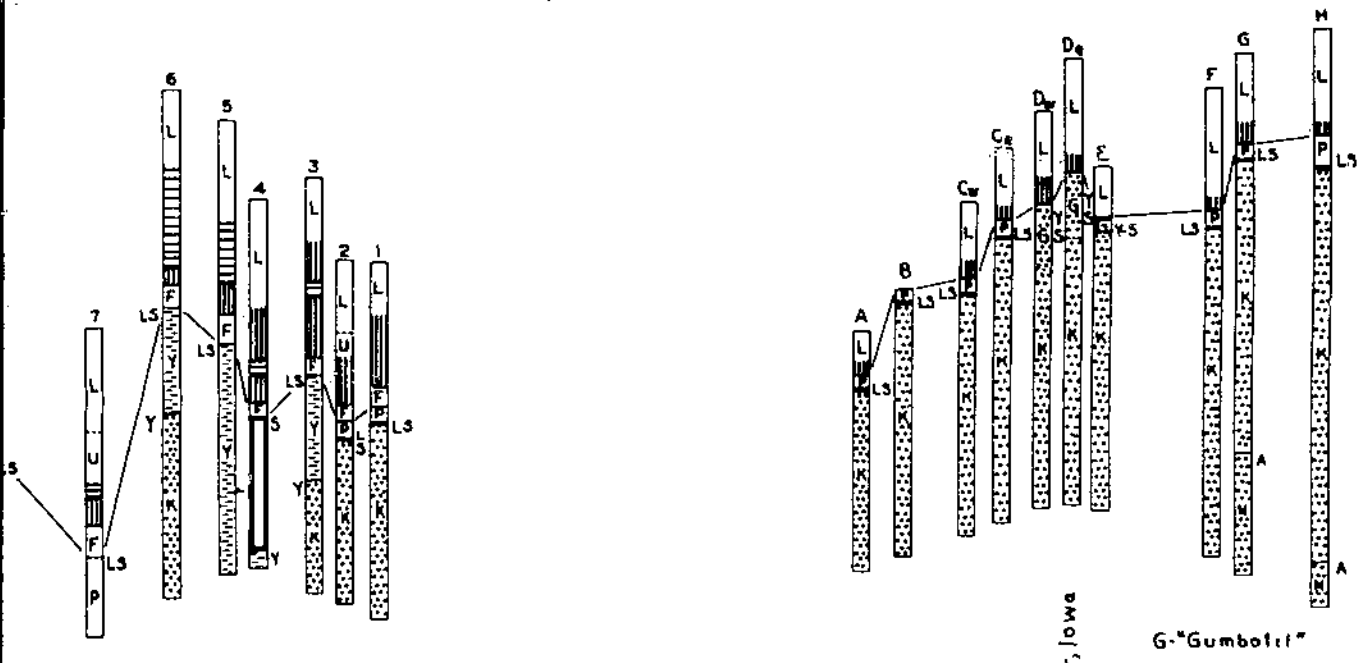

LANDSCAPE EVOLUTION AND SOIL FORMATION IN SOUTHWESTERN IOWA. USDA Technical Bulletin 1349.

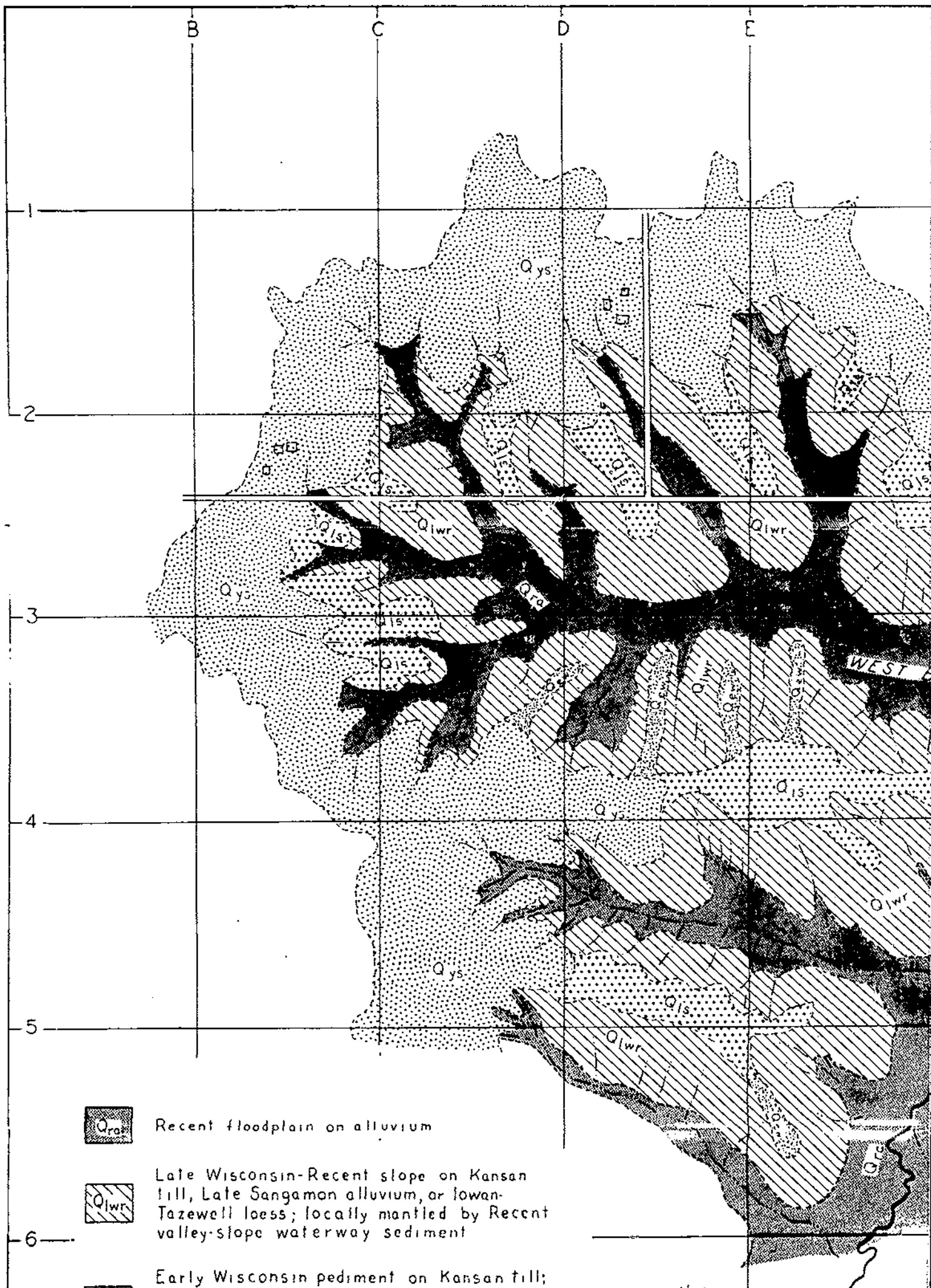

SOUTH TURKEY CREEK AREA
ADAIR COUNTY, IOWA

SCALE

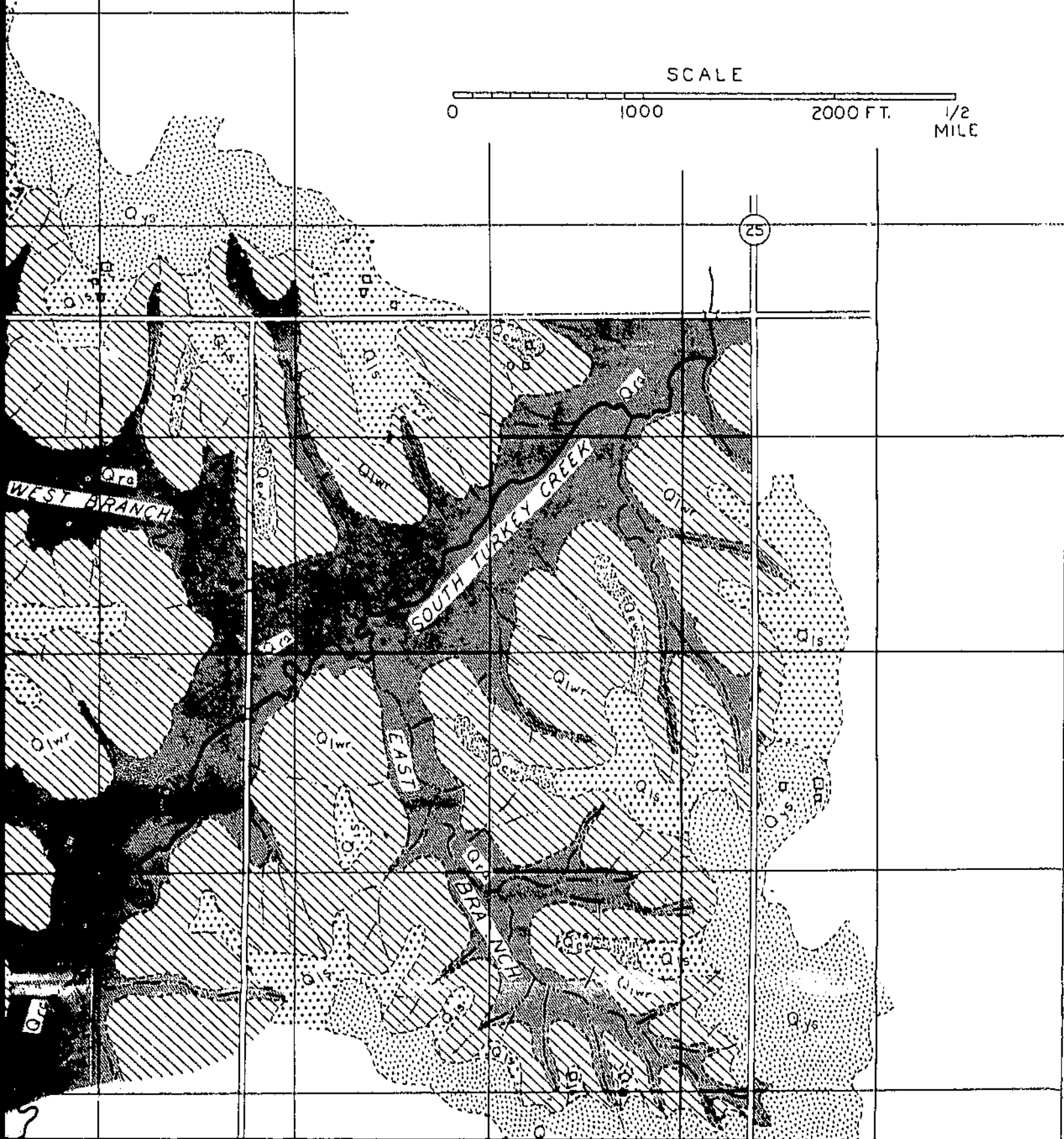

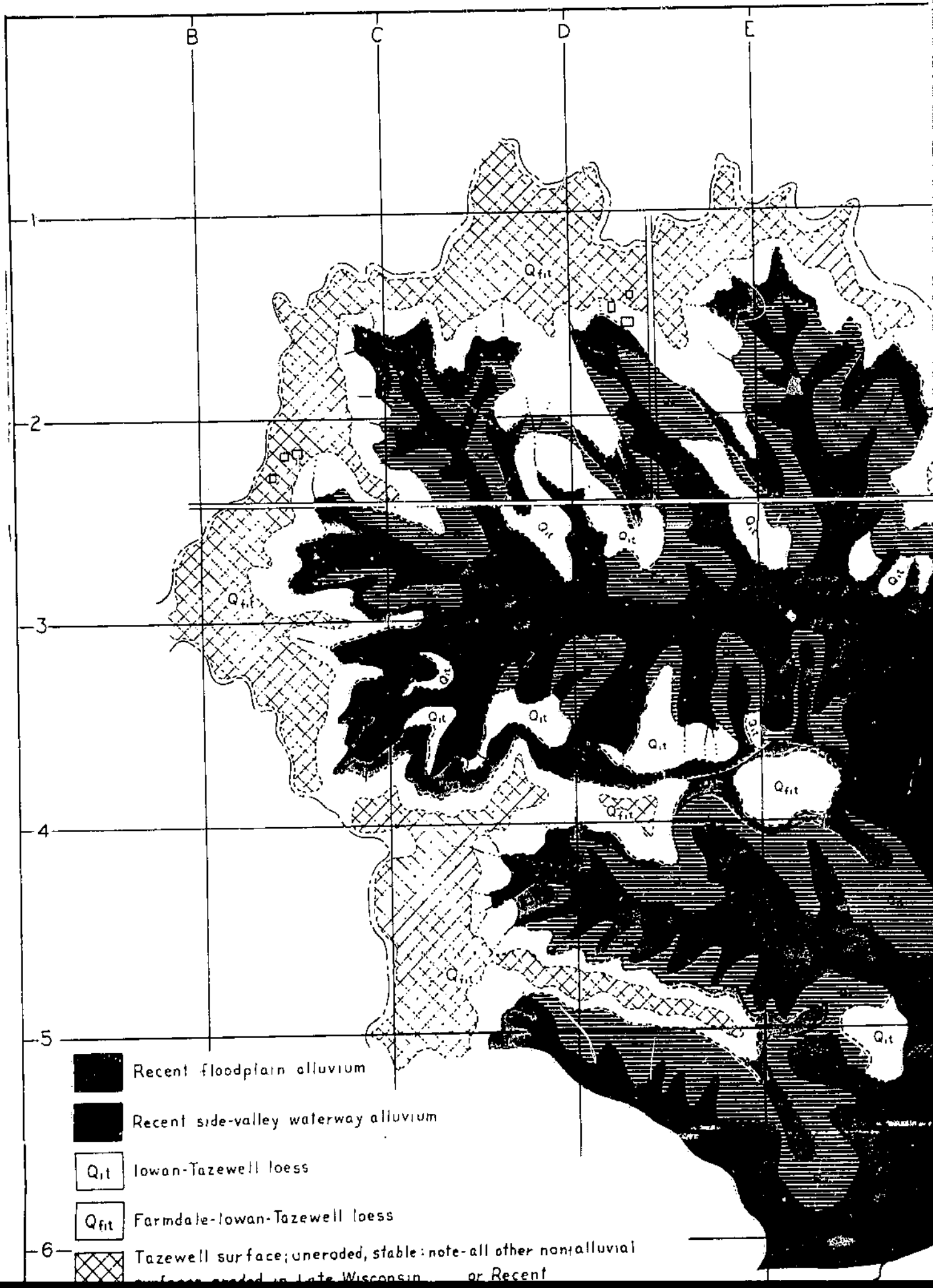

F

G

H

I

J

SOUTH TURKEY CREEK AREA ADAIR COUNTY, IOWA

SCALE

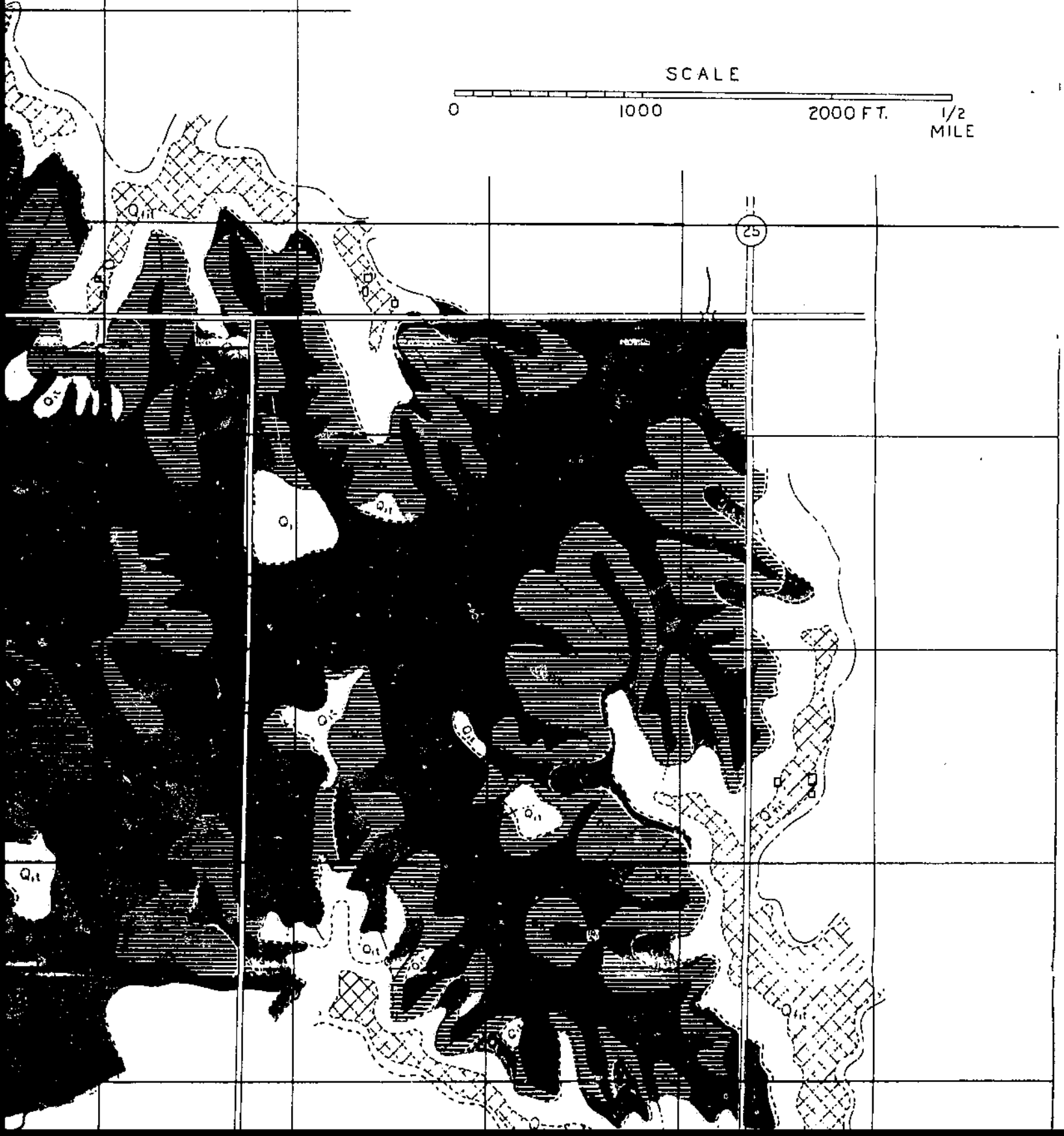
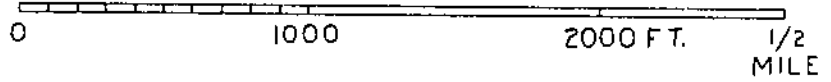



NORTH TURKEY CREEK AREA ADAIR COUNTY, IOWA

SCALE

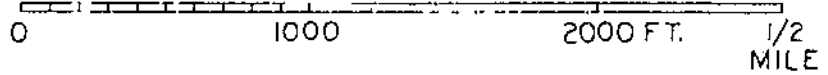

24	R.32W.	19	20
25	T.77N. R.31W.	30	29

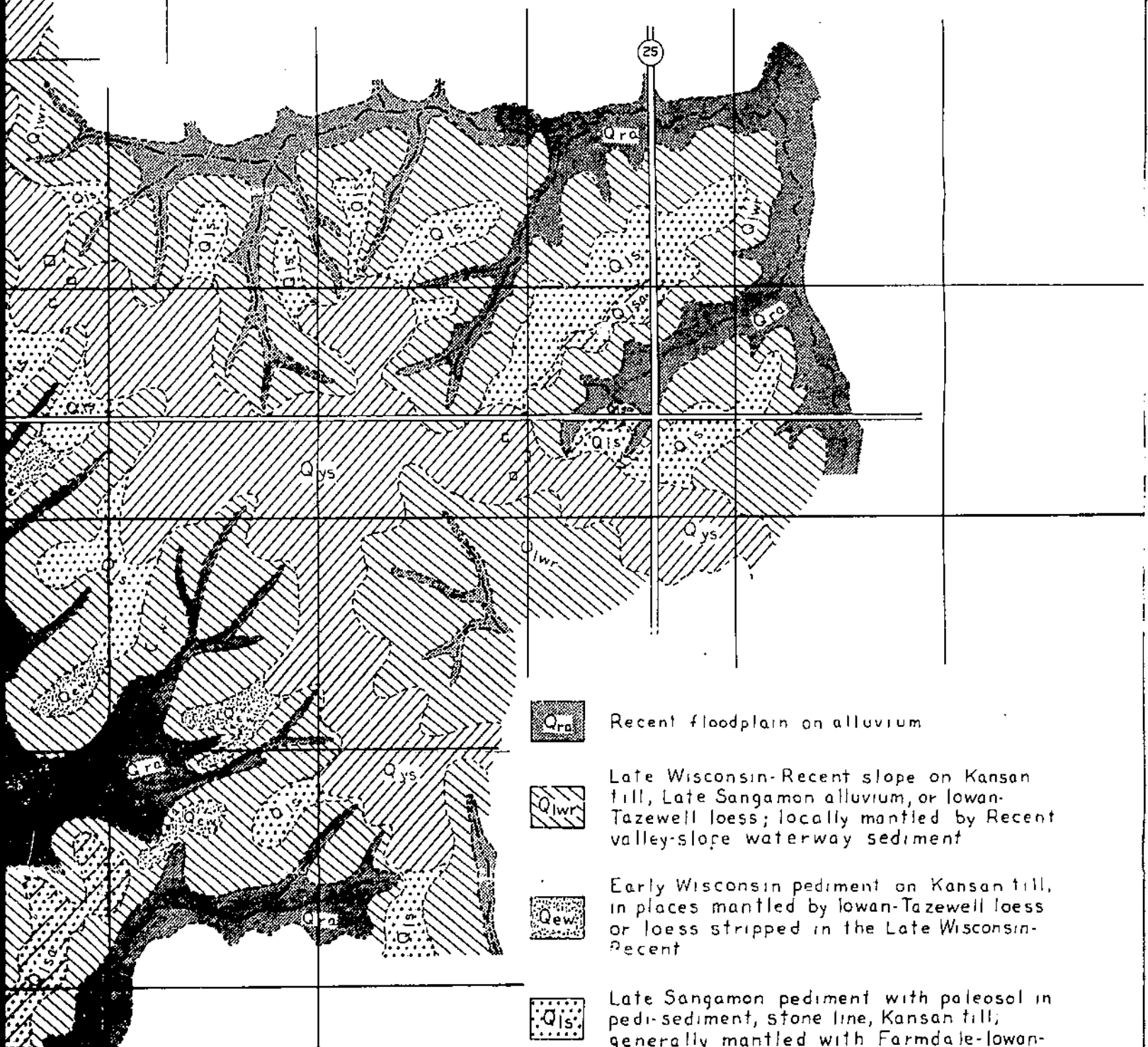

- Q_{ra} Recent floodplain on alluvium
- Q_{lwr} Late Wisconsin-Recent slope on Kansan fill, Late Sangamon alluvium, or lowan-Tazewell loess; locally mantled by Recent valley-slope waterway sediment
- Q_{ew} Early Wisconsin pediment on Kansan till, in places mantled by lowan-Tazewell loess or loess stripped in the Late Wisconsin-Recent
- Q_{ls} Late Sangamon pediment with paleosol in pedi-sediment, stone line, Kansan till; generally mantled with Farmdale-lowan-

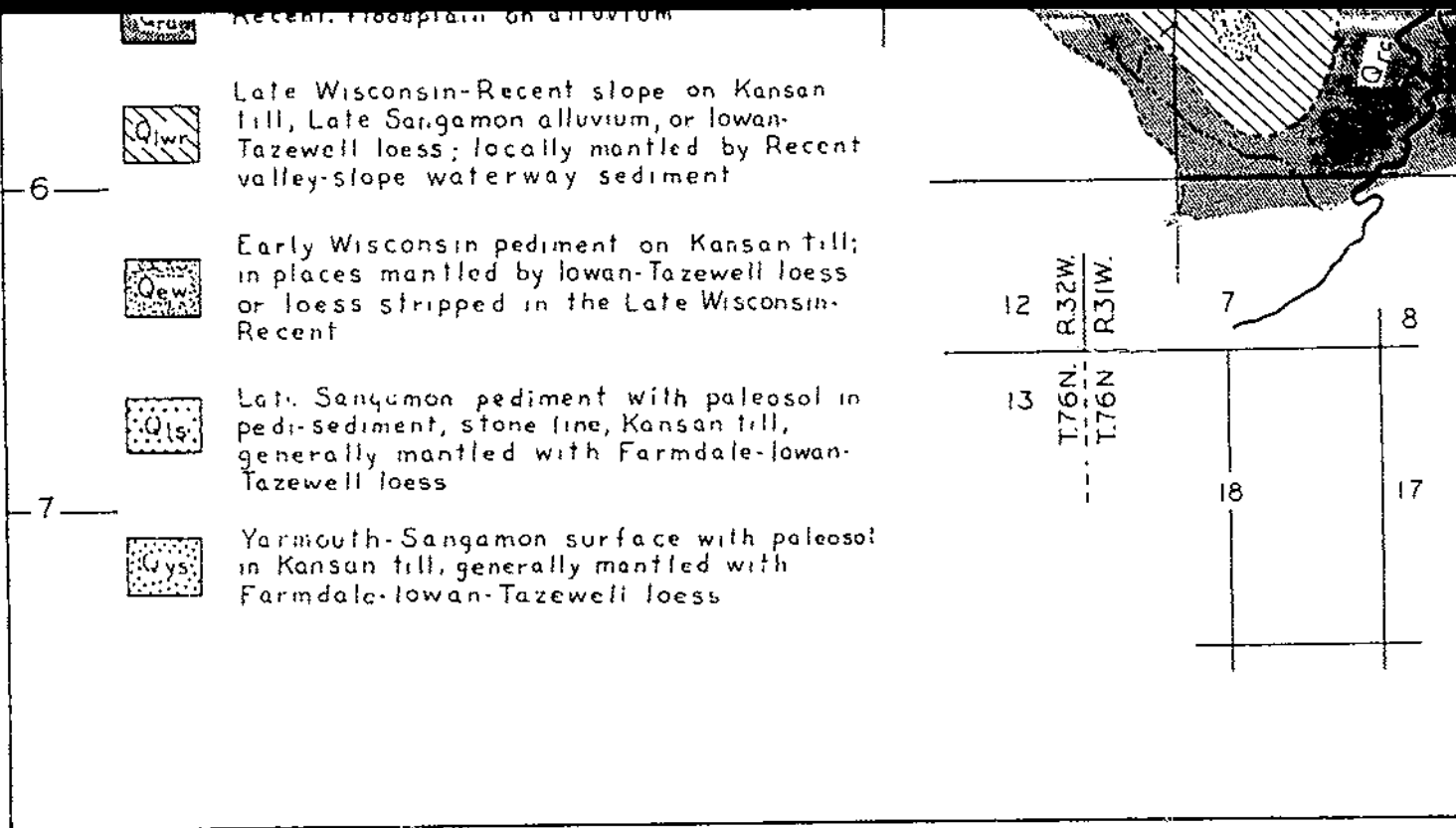
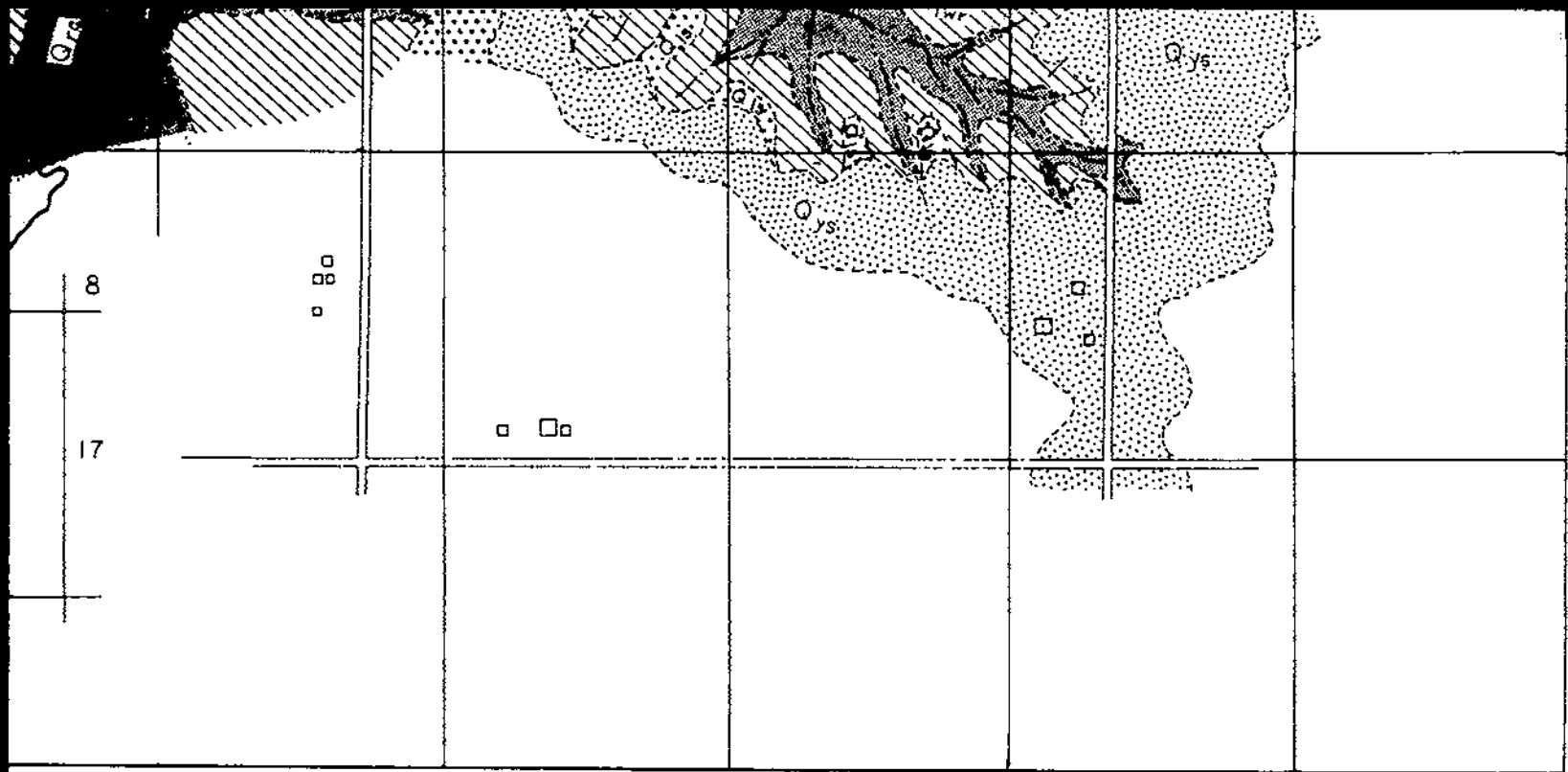

Plate II. Geomorphic surfaces, South Turkey Creek area.



LANDSCAPE EVOLUTION AND SOIL FORMATION IN SOUTHWESTERN IOWA. USDA Technical Bulletin 1349.

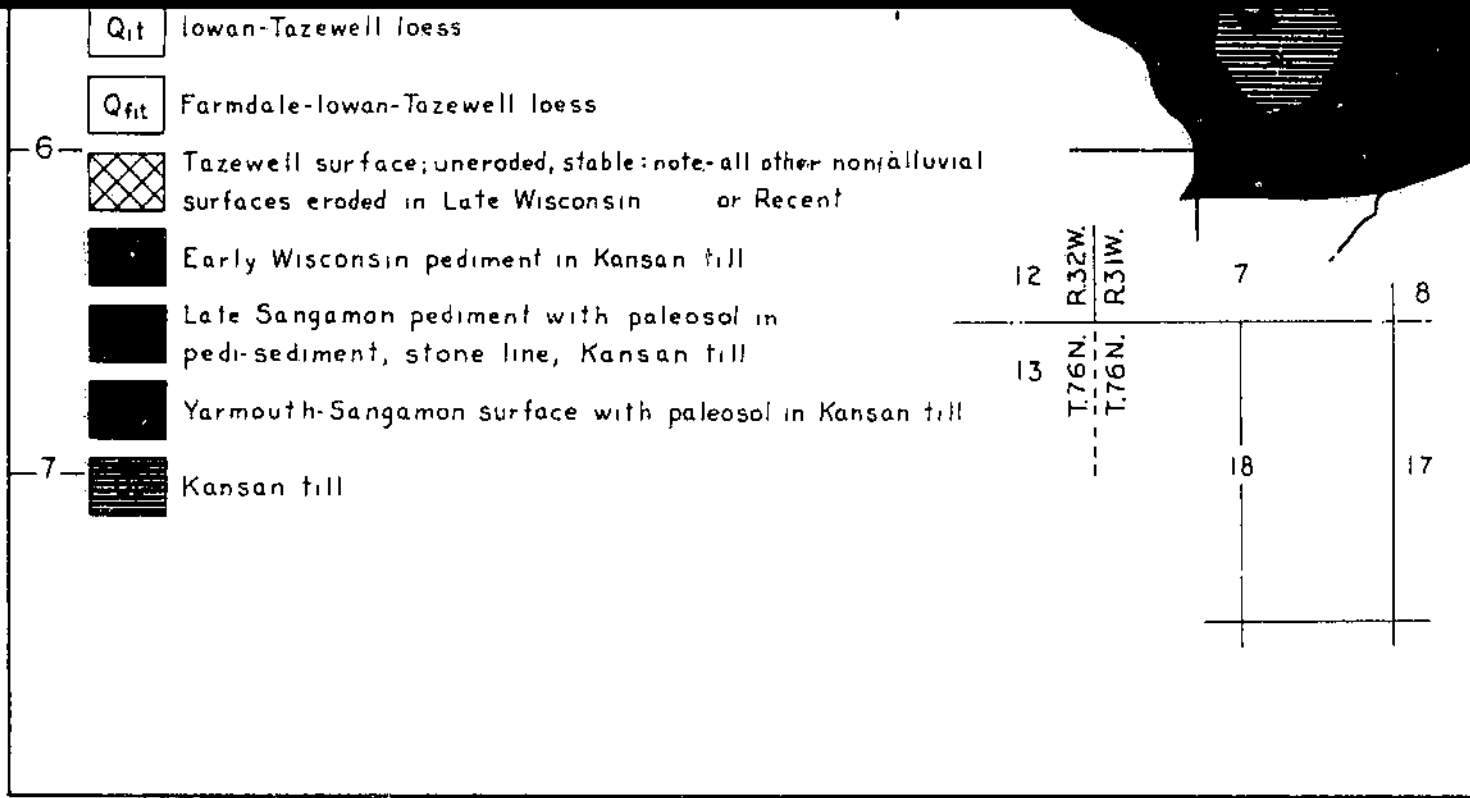
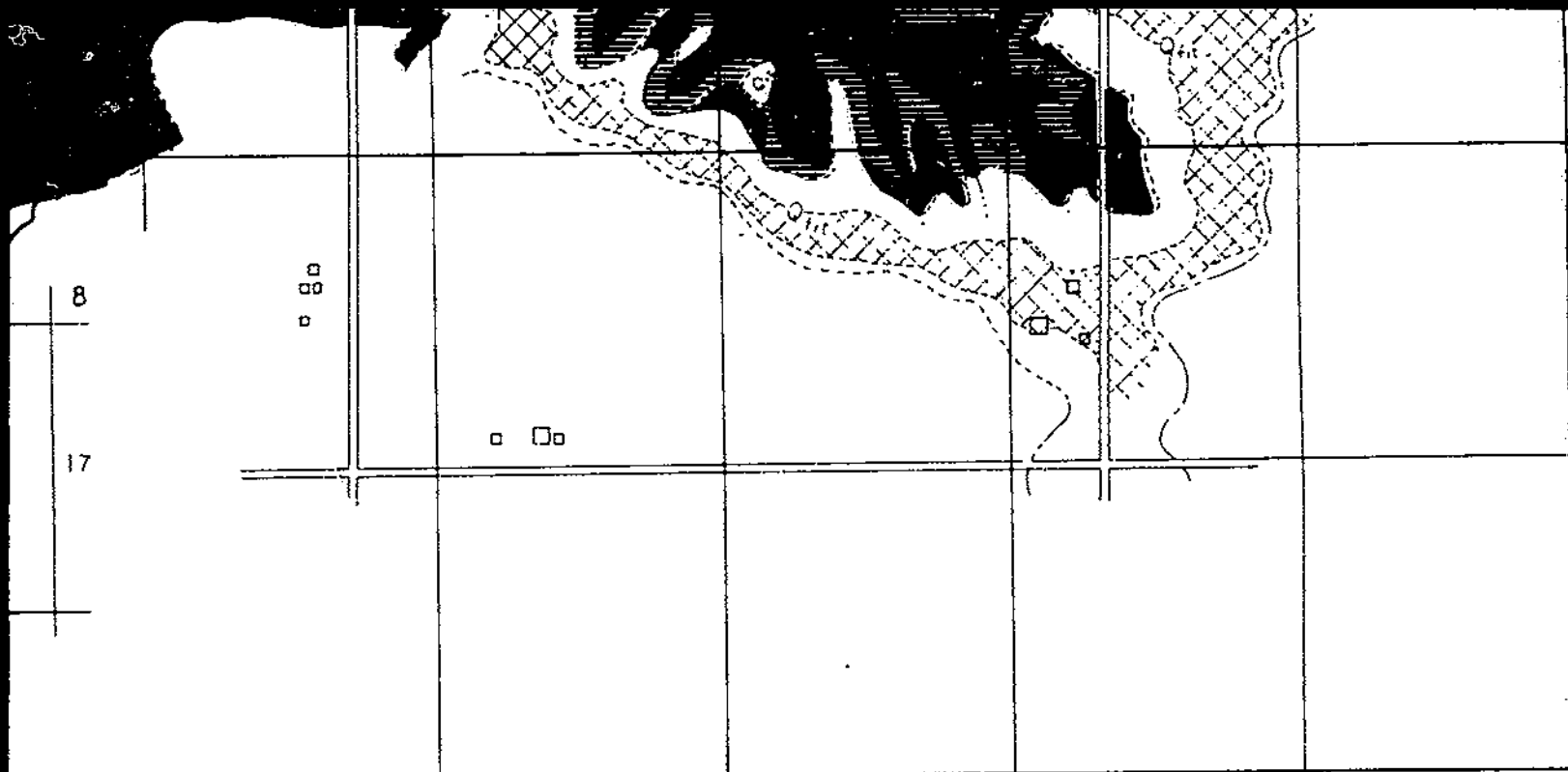

Plate III. Geomorphic surfaces and surficial deposits, South Turkey Creek area.



LANDSCAPE EVOLUTION AND SOIL FORMATION IN SOUTHWESTERN IOWA. USDA Technical Bulletin 1349.

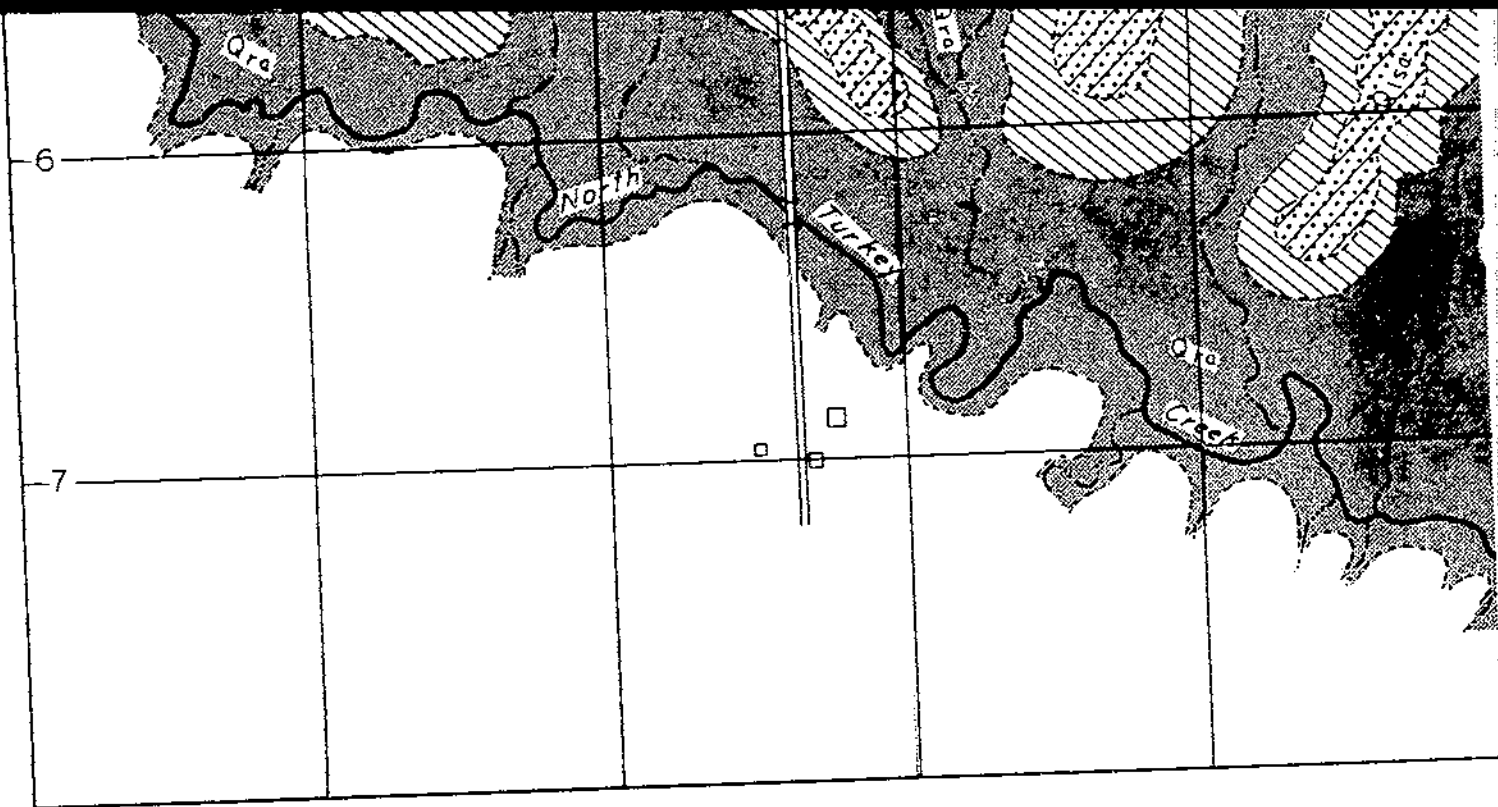
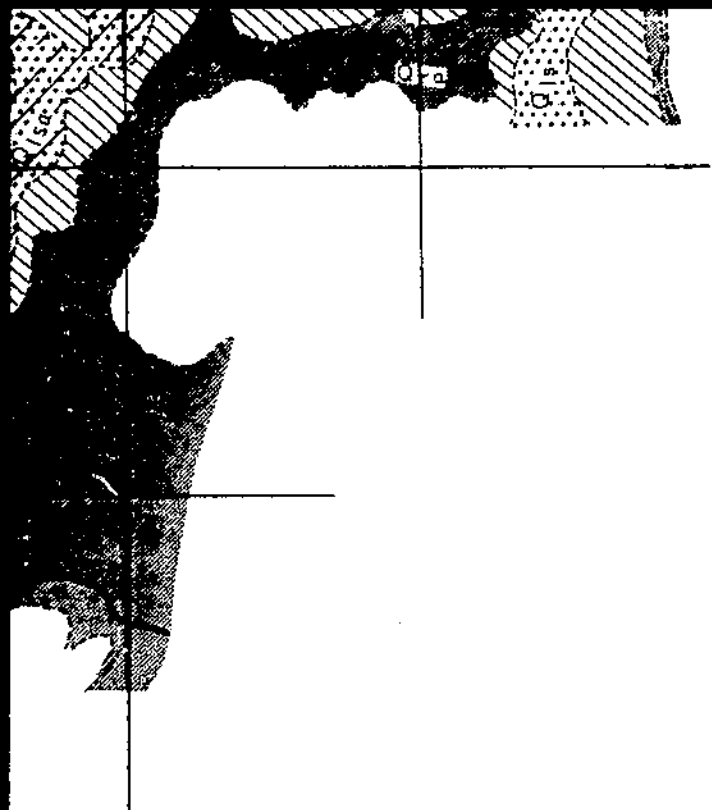

Plate IV. Geomorphic surfaces, North Turkey Creek area.



Qew

Early Wisconsin pediment on Kansan till, in places mantled by lowan-Tazewell loess or loess stripped in the Late Wisconsin-Recent

Qls

Late Sangamon pediment with paleosol in pedi-sediment, stone line, Kansan till; generally mantled with Farmdale-lowan-Tazewell loess

Qlsa

Late Sangamon valley-fill surface with paleosol in alluvium; generally mantled with Farmdale-lowan-Tazewell loess

Qys

Yarmouth-Sangamon surface with paleosol in Kansan till; generally mantled with Farmdale-lowan-Tazewell loess

LANDSCAPE EVOLUTION AND SOIL FORMATION IN SOUTHWESTERN IOWA. USDA Technical Bulletin 1349.



SOILS LEGEND

Soils In Tazewell Loess

- 11 Sharpsburg silty clay loam
- 12 Sharpsburg silty clay loam-0-1 percent slopes
- 13 Sharpsburg silty clay loam, deoxidized substratum phase
- 11A Sharpsburg silty clay loam, moderately shallow to till
- 11B Sharpsburg silty clay loam, moderately shallow to Yarmouth-Sangamon paleosal
- 11C Sharpsburg silty clay loam, moderately shallow to late Sangamon paleosal

Soils In Kansan Till - Late Wisconsin-Recent

- 6 Shelby clay loam, moderately shallow to carbonates
- 6 Shelby clay loam, deep to carbonates
- 6 Shelby loam, sandy subsoil variant

SOUTH TURKEY CREEK AREA
ADAIR COUNTY, IOWA

SCALE

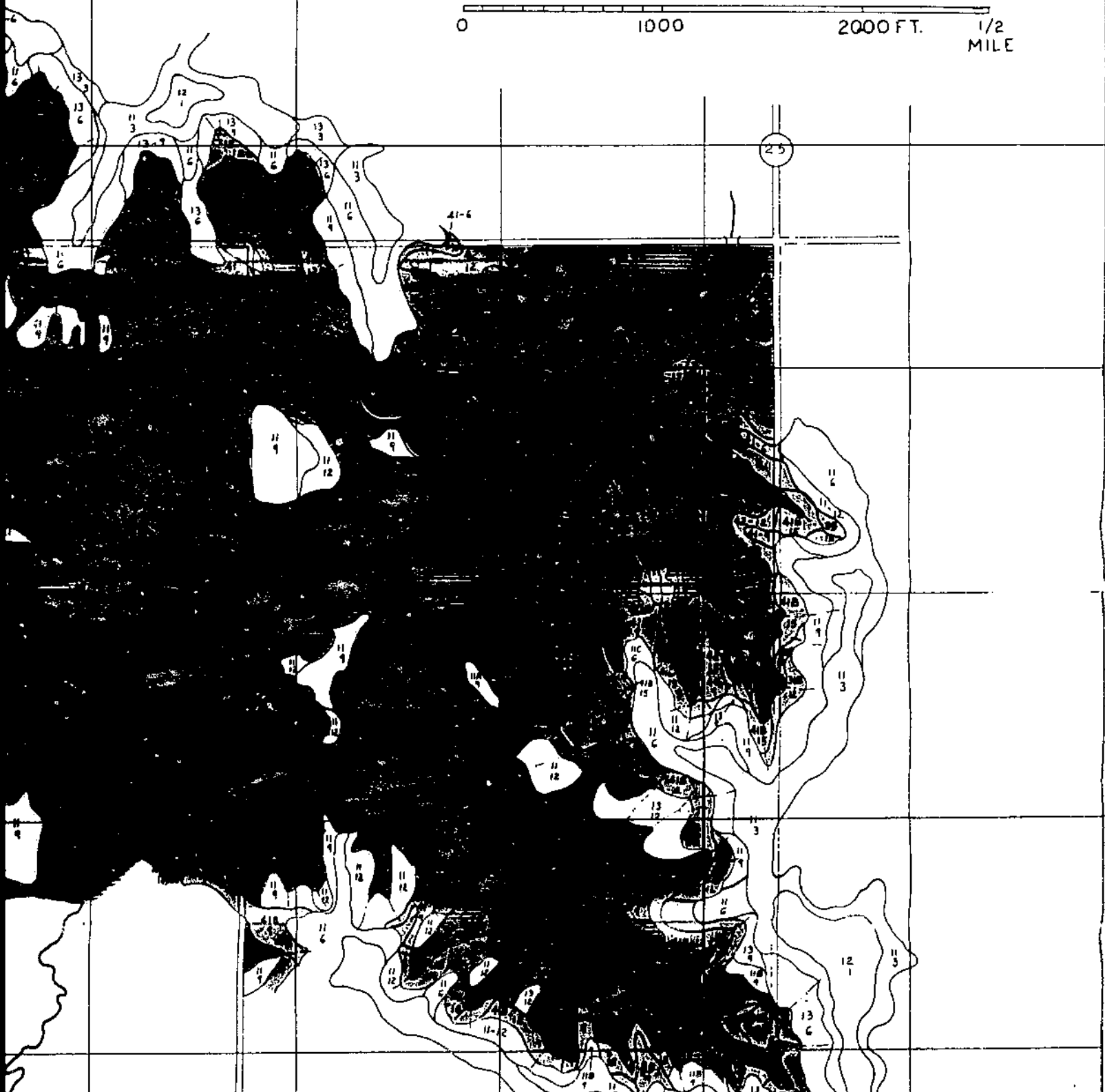
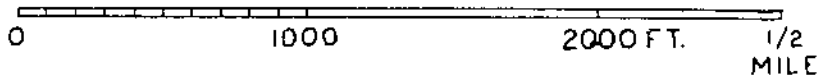

- I** Sharpsburg silty clay loam, moderately shallow to till
- IIA** Sharpsburg silty clay loam, moderately shallow to Yarmouth-Sangamon paleosol
- IIB** Sharpsburg silty clay loam, moderately shallow to Yarmouth-Sangamon paleosol
- IIC** Sharpsburg silty clay loam, moderately shallow to late Sangamon paleosol

Soils in Kansan Till - Late Wisconsin-Recent

- 6** Shelby clay loam, moderately shallow to carbonates
- 6** Shelby clay loam, deep to carbonate
- 6** Shelby loam, sandy subsoil variant
- 6** Shelby-Steinauer intergrade clay loam
- 6** Steinauer clay loam

Paleosols in Kansan Till
Yarmouth-Sangamon Paleosols

- 7** Clarinda silty clay loam

Late Sangamon Paleosols

- 7** Adair-Clarinda intergrade silty clay loam
- 7** Adair silt loam
- 7** Adair clay loam
- 7** Adair clay loam

Soils in Alluvium and Waterway Sediments

- 7** Undifferentiated soils in alluvium
- 7** Arbor silt loam
- 7** Olmitz silty clay loam

Tentative field correlations by F. J. Cortisale.

Note: An eroded phase of a soil is designated by the insertion of the Arabic numeral 1 following the soil mapping number. For example, an eroded, > 4 inches of A horizon remaining, Shelby clay loam, deep to carbonate, is designated as 21A. If less than 4 inches of A horizon is present, the soil is designated as 21IA.

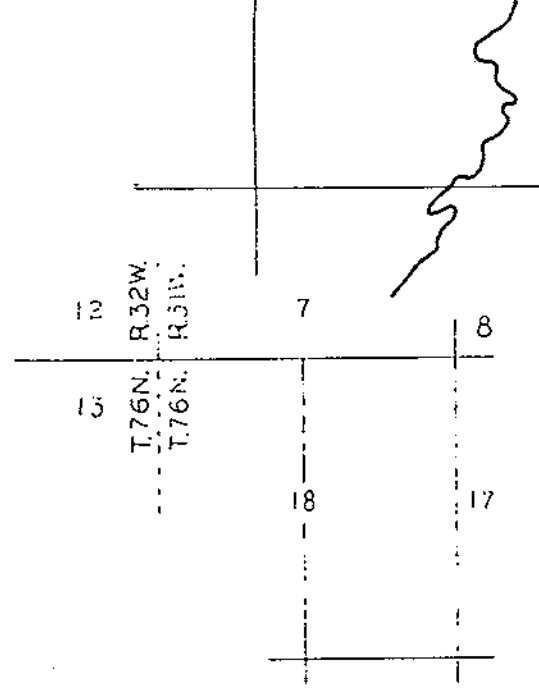
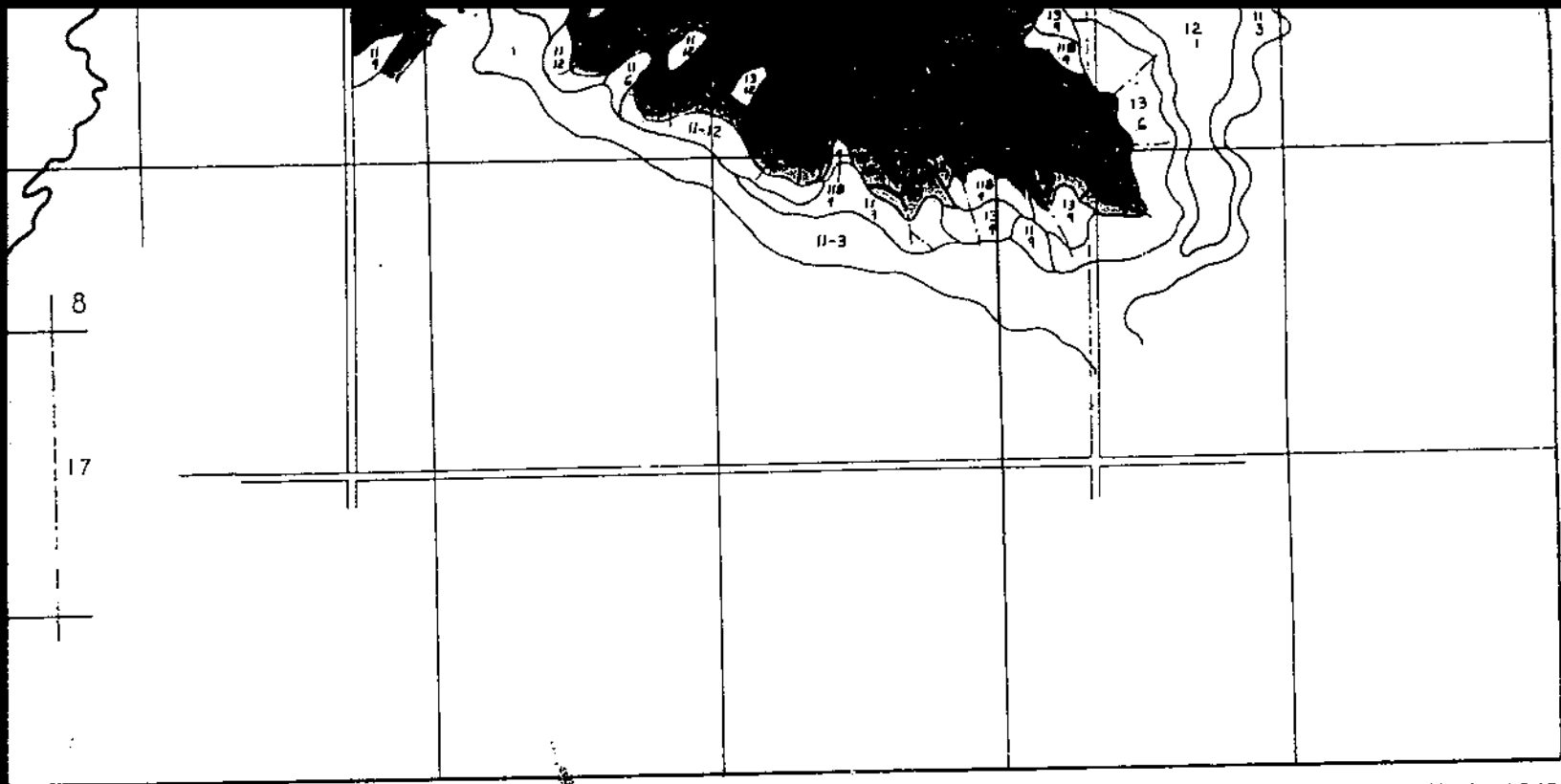

Plate V Soil map of the South Turkey Creek area.



LANDSCAPE EVOLUTION AND SOIL FORMATION IN SOUTHWESTERN IOWA. USDA Technical Bulletin 1349.

END