



AgEcon SEARCH
RESEARCH IN AGRICULTURAL & APPLIED ECONOMICS

The World's Largest Open Access Agricultural & Applied Economics Digital Library

This document is discoverable and free to researchers across the globe due to the work of AgEcon Search.

Help ensure our sustainability.

Give to AgEcon Search

AgEcon Search
<http://ageconsearch.umn.edu>
aesearch@umn.edu

*Papers downloaded from **AgEcon Search** may be used for non-commercial purposes and personal study only. No other use, including posting to another Internet site, is permitted without permission from the copyright owner (not AgEcon Search), or as allowed under the provisions of Fair Use, U.S. Copyright Act, Title 17 U.S.C.*

TB 249 (1931)

USDA TECHNICAL BULLETINS

UPDATA

SOME FACTORS AFFECTING THE VISCOSITY OF CREAM

BARCOCK, C. J.

1 OF 1

START

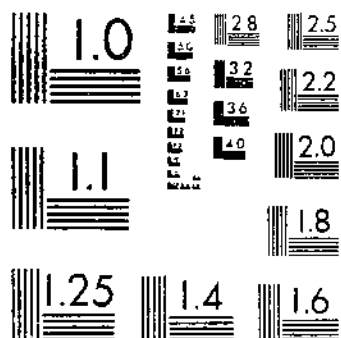

MICROCOPY RESOLUTION TEST CHART
NATIONAL BUREAU OF STANDARDS-1963-A

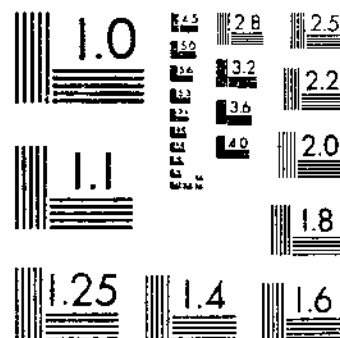

MICROCOPY RESOLUTION TEST CHART
NATIONAL BUREAU OF STANDARDS-1963-A



UNITED STATES DEPARTMENT OF AGRICULTURE
WASHINGTON, D. C.

SOME FACTORS AFFECTING THE
VISCOSITY OF CREAM

By C. J. BARCOCK

Market-Milk Specialist, Division of Market-Milk Investigations, Bureau of Dairy Industry

CONTENTS

	Page		Page
Introduction.....	1	Factors affecting viscosity—Continued.	
Method used for measuring viscosity.....	2	Effect of acidity.....	8
Method used for microscopic studies.....	2	Effect of cooling.....	10
Factors affecting viscosity.....	3	Effect of separating temperature.....	11
Effect of butterfat content and tempera- ture.....	3	Effect of storage of milk.....	12
Effect of age upon viscosity.....	4	Effect of pasteurizing before separating..	12
Effect of pasteurizing temperature.....	6	Effect of homogenization.....	13
Gravity-separated and centrifugally separated cream compared.....	7	Effect of homogenizing temperature.....	14
Effect of standardization.....	8	Effect of rehomogenization.....	16
Effect of freezing.....	9	Effect of solids not fat.....	16
		Conclusions.....	18
		Literature cited.....	18

INTRODUCTION

Throughout the market-cream industry much difficulty is encountered by producers in preparing and marketing cream on account of variations in what is commonly referred to as "body". Consumers judge the quality of their cream supply mostly by its appearance; if the cream seems to be heavy or thick, its appearance is taken to indicate a high butterfat content, and vice versa. Therefore it is to the best interest of the dairies to supply a product which is uniform in appearance day after day. Dairies are attempting to do this and at the same time to supply a product with a good body. However, there is a tendency for the body of cream to vary even when the cream-handling processes are the same.

The experiments reported in this bulletin were made in order to determine, if possible, some of the causes for the variations in the body of cream, body being an important commercial factor. The body of cream, as determined by capillary flow, is reported throughout this work as viscosity. The fact that cream at the higher fat concentrations and lower temperatures gave indications of pseudo-plasticity has not been considered.

METHOD USED FOR MEASURING VISCOSITY

Viscosity may be defined as the internal friction of a liquid, the resistance to shear or flow. Usually it is measured by an instrument called a viscosimeter or viscometer, which permits a certain volume of liquid to discharge through a short capillary tube. The time of discharge is recorded in seconds. When the same instrument is used purely as a relative measure for the direct comparison of different liquids, the time of discharge in seconds makes an accurate comparison. If the make of instrument is stated and well known, the time in seconds may be used for the determination of viscosity with reference to a particular standard.

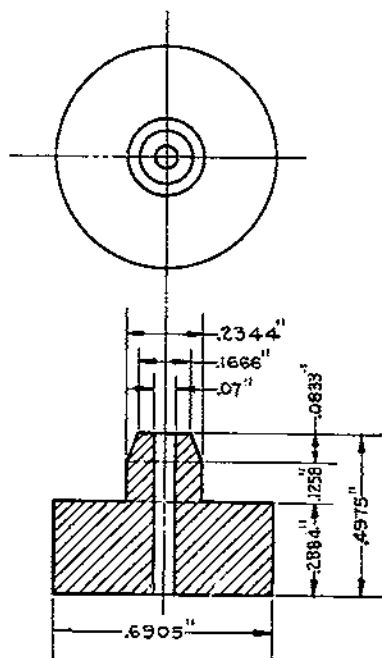

FIGURE 1.—Diagram showing orifice of the viscometer used in determining the viscosity of cream

In this work an instrument similar to the standard Saybolt viscometer was used, the main difference being that the orifice, which was 0.07 inch in diameter, was removable. (Fig. 1.) The viscometer held 70 cubic centimeters of liquid, and the time required for the discharge of the first 60 cubic centimeters was recorded in seconds. For the maintenance of constant temperatures, the viscometer was surrounded by a water bath. The temperature was determined by a thermometer passed through the lid of the viscometer into the center of the liquid within the viscometer. The results,

which in nearly every case represent the average of at least 25 determinations, are recorded herein as relative viscosity, which may be defined as the relative internal friction of a liquid, and determined by taking that of water at the same temperature as equal to 1.

METHOD USED FOR MICROSCOPIC STUDIES

On account of the vast number of fat globules in cream it was necessary to dilute the cream before making a microscopic study. In this work the cream was diluted with a solution which was similar to that used by Van Dam and Sirks (10).² This solution consisted of 1½ parts of gelatin dissolved in 100 parts of water, to which phenol was added to make the solution 1 per cent phenol. This made a very satisfactory diluent, as the gelatin held the fat globules, thereby preventing the "Brownian movement." The phenol acted as a preservative agent, keeping the microscopic slides constant for a longer period and thus permitting a more accurate comparison

² Italic numbers in parenthesis refer to Literature Cited, p. 18.

of different slides. In this work the cream was diluted by using 1 part of cream to 100 parts of solution. In order that the amounts of cream on the slides would be comparable, a platinum loop was used to transfer a drop of the mixture to the slide. This drop was then covered with an ordinary cover glass.

FACTORS AFFECTING VISCOSITY

One of the main factors affecting the viscosity of cream is the physical state of the butterfat therein. The butterfat of fresh cream occurs mainly as individual globules, ranging in diameter from 0.1 to 22 microns. However, the greater number are below 10 microns, 3 microns being given by most investigators as the average size. The cream used in this investigation was, unless otherwise stated, centrifugally separated from the mixed milk of a herd consisting of Holstein, Jersey, and Guernsey cattle. The fat globules in 50 different samples of the cream averaged 3.19 microns.

There is a tendency for the fat globules to coalesce or to adhere to one another, forming aggregates or clumps. The degree of clumping depends largely upon temperature, size of globules, and agitation. Investigators agree that maximum clumping takes place at 7° to 8° C., and that above 60° little or no clumping occurs.

The larger fat globules apparently clump more readily than the smaller ones, for a microscopic examination of cream shows that the clumps contain but a very small proportion of the smaller fat globules. The fact that the fat remaining in skim milk is mostly in the form of globules less than 3 microns in diameter, indicates that the smaller globules have less tendency to coalesce.

As it is necessary for the globules to come into contact with one another before they can coalesce, agitation at temperatures favorable to coalescence increases the degree of clumping, whereas agitation at temperatures unfavorable to coalescence tends to disperse the globules or to separate the clumps previously formed.

Any factor which affects the clumping of fat globules affects the viscosity of cream. The clumping of globules begins in milk before separation. Centrifugal separation undoubtedly breaks up or disperses many of the clumps previously formed and at the same time forms many new clumps. Likewise, the various processes through which cream passes before reaching the consumer may alter the clumping of globules and thereby affect the viscosity of the cream.

EFFECT OF BUTTERFAT CONTENT AND TEMPERATURE

Whitaker, Sherman, and Sharp (20) report that the viscosity of skim milk decreases as the temperature is raised. Dahlberg and Hening (8) report that increasing the percentages of fat in milk and cream always increased the viscosity of the milk or cream, but the effect of increasing the amount of the fat was most marked when the cream contained 20 to 35 per cent fat and was aged but not pasteurized.

In the work reported herein the viscosity of cream increased as the butterfat content increased. The higher the butterfat content the more marked was the increase in viscosity with further increase in fat content. This was true especially when the measurements were

made at a low temperature, for the viscosity of cream depends upon its temperature. The viscosity was lower at the higher temperatures. The decrease in viscosity was rapid until a temperature of about 32° C. (the melting point of butterfat) was reached. Heating the cream above the melting point of butterfat caused either a gradual decrease or practically no change in viscosity until a temperature of 80° was reached. At 80° a slight increase in viscosity took place. (Tables 1 and 2, and figs. 2 and 3.)

TABLE 1.—Effect of butterfat content on the viscosity of raw cream at 20° C.

Butterfat (per cent)	Relative viscosity	Butterfat (per cent)	Relative viscosity	Butterfat (per cent)	Relative viscosity
18	1.42	26	1.72	32	2.28
20	1.47	28	1.85	34	2.60
22	1.55	30	2.03	36	3.13
24	1.63				

TABLE 2.—Effect of temperature on the relative viscosity of cream

Temperature (°C.)	Relative viscosity of—			Temperature (°C.)	Relative viscosity of—		
	20 per cent cream	30 per cent cream	40 per cent cream		20 per cent cream	30 per cent cream	40 per cent cream
5	2.07	3.37	20.10	45	1.26	1.45	1.79
10	1.86	2.57	11.40	50	1.24	1.44	1.75
15	1.66	2.35	9.74				
20	1.51	2.03	4.82	55	1.24	1.42	1.71
25	1.40	1.81	3.29	60	1.24	1.41	1.68
				65	1.21	1.40	1.66
30	1.35	1.65	2.38	70	1.24	1.39	1.64
35	1.29	1.53	1.99	75	1.24	1.39	1.64
40	1.27	1.48	1.86	80	1.25	1.40	1.66

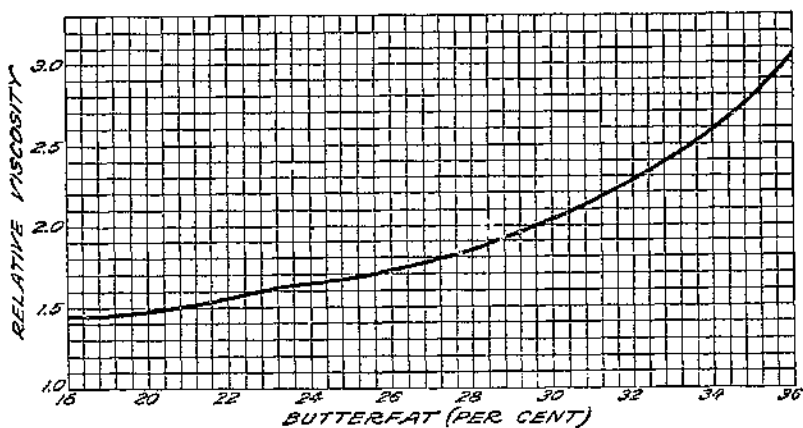

FIGURE 2.—Effect of butterfat content on the viscosity of raw cream at 20° C.

EFFECT OF AGE UPON VISCOSITY

Aging cream at a low temperature (5° C.) increased its viscosity. The greatest increase took place during the first 24 hours of aging, and at 48 hours the maximum was approached. A further, but very

gradual, increase in viscosity resulted from aging the cream longer than 48 hours. The increase in viscosity due to aging was greater for cream with a high butterfat content than for cream with a low butterfat content.

The increase in viscosity due to aging was greater with raw cream than with pasteurized cream. Pasteurizing the cream not only lowered the viscosity, but the effect of pasteurization was such that unless the cream had a high butterfat content, aging for 96 hours did not restore the cream to its original viscosity.

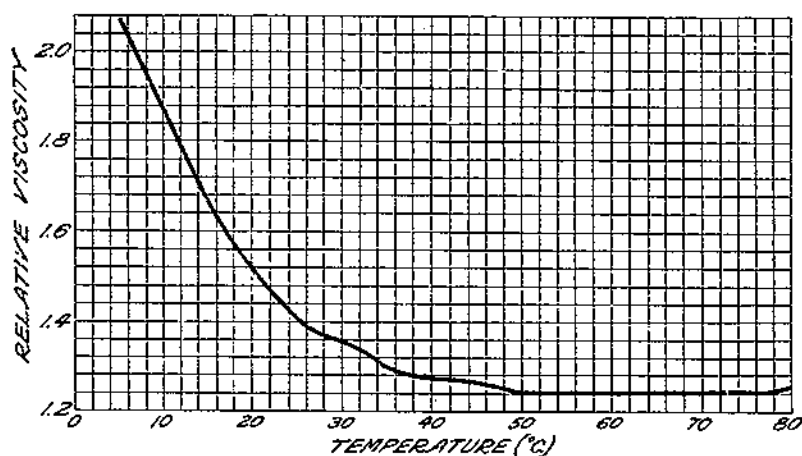

FIGURE 3.—Effect of temperature on the viscosity of 20 per cent cream

Homogenization increased the viscosity of both raw cream and pasteurized cream. The rate of increase in viscosity with age, however, was somewhat less for raw homogenized cream than for pasteurized unhomogenized cream. Contrary to the work of Sherwood and Smallfield (17), who state that the rate of increase in viscosity with age of a pasteurized homogenized cream is much greater than that of a pasteurized unhomogenized cream, the viscosity of pasteurized homogenized cream did not increase with age. (Table 3 and fig. 4.)

TABLE 3.—Effect of age upon the relative viscosity of cream

Character of cream	Butterfat	Temperature of cream	Relative viscosity					
			Fresh	At 3 hours	At 24 hours	At 43 hours	At 72 hours	At 96 hours
Raw.....	Per cent	°C.						
Pasteurized.....	20	5	1.76	1.80	1.98	2.05	2.14	2.21
Raw.....	20	5	1.48	1.51	1.54	1.56	1.59	1.61
Raw.....	30	5	2.55	2.84	3.03	4.49	4.70	4.83
Pasteurized.....	30	5	2.55	2.44	2.56	2.67	2.75	2.79
Raw, homogenized at 2,000 pounds.....	20	20	2.12	-----	2.13	2.14	2.15	2.19
Pasteurized, homogenized at 2,000 pounds.....	20	20	1.92	-----	1.92	1.92	1.92	1.92

The increase in viscosity of cream with age was accompanied by an increase in the clumping of fat globules. The clumping of fat globules was slightly more pronounced in raw cream than in pasteurized cream; and the additional clumping of fat globules with age was more pronounced in raw cream. (Pls. 1 to 4, inclusive.)

The increase in viscosity due to the clumping of fat globules was reported by Babcock (2). He concluded that, although the globules in the clumps are not very firmly bound together, the clumps have, under ordinary conditions, sufficient stability to add very considerably to the consistency of milk. However, factors other than the clumping of fat globules may enter into the increase in viscosity of

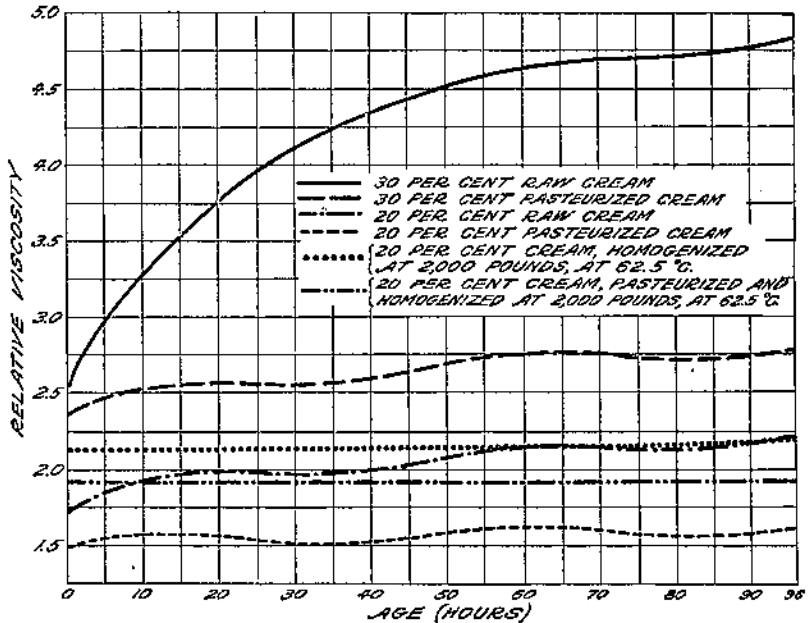

FIGURE 4.—Effect of age upon the viscosity of cream

cream with age, for Bateman and Sharp (5) found an increase in viscosity of skim milk with age; and Dahlberg and Hening (8) reported that aging greatly increased the viscosity of most of the rich cream and also had some effect even upon skim milk.

EFFECT OF PASTEURIZING TEMPERATURE

Babcock and Russell (3, 4), Woll (22), Steiner (18), Evenson and Ferris (13), Dahlberg and Hening (8), Whitaker, Sherman, and Sharp (20), and others, found that the viscosity of milk and skim milk is lowered by pasteurization. Some of these investigators, however, reported an increase in viscosity at the higher pasteurizing temperatures. Achard and Stassano (1), disagreeing with the majority, reported a slight increase in the viscosity of milk when pasteurized.

The work of the present writer indicated that, although pasteurization lowered the viscosity of cream, the temperature at which the cream was pasteurized had but little effect upon viscosity. Cream

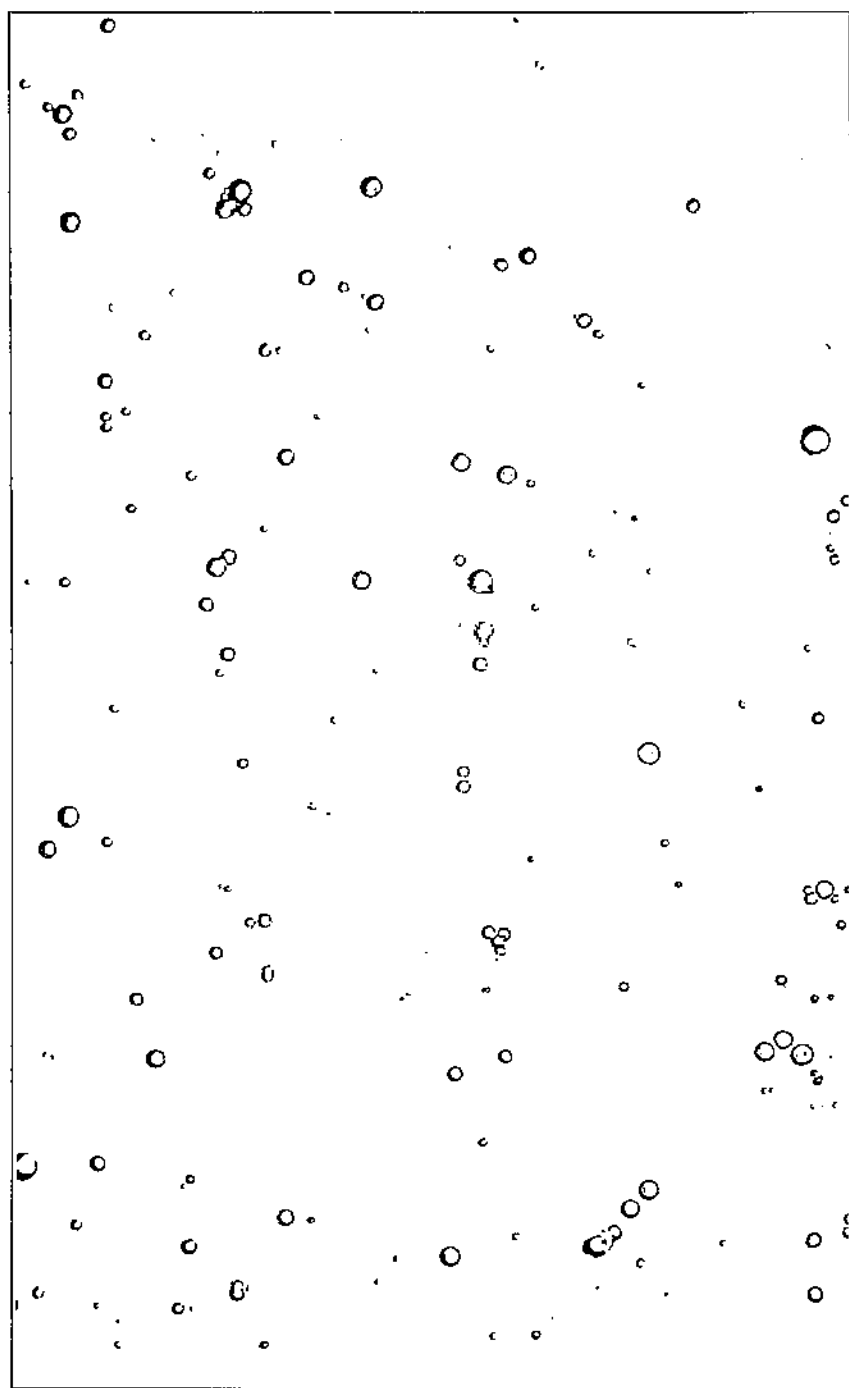

FAT GLOBULES IN FRESHLY SEPARATED 20 PER CENT RAW CREAM. X 500

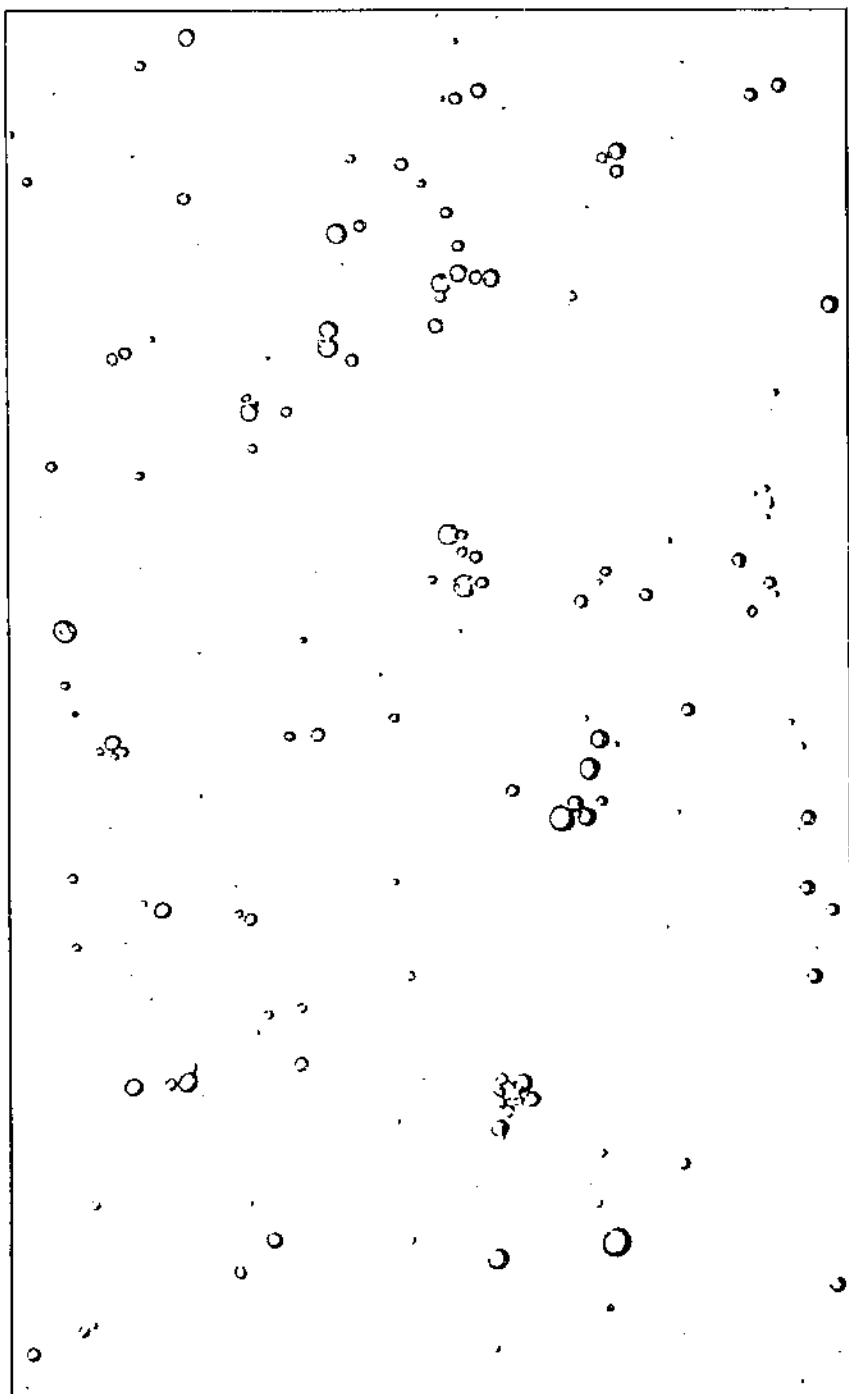

FAT GLOBULES IN 20 PER CENT RAW CREAM AFTER AGING FOR 72 HOURS.
X 500

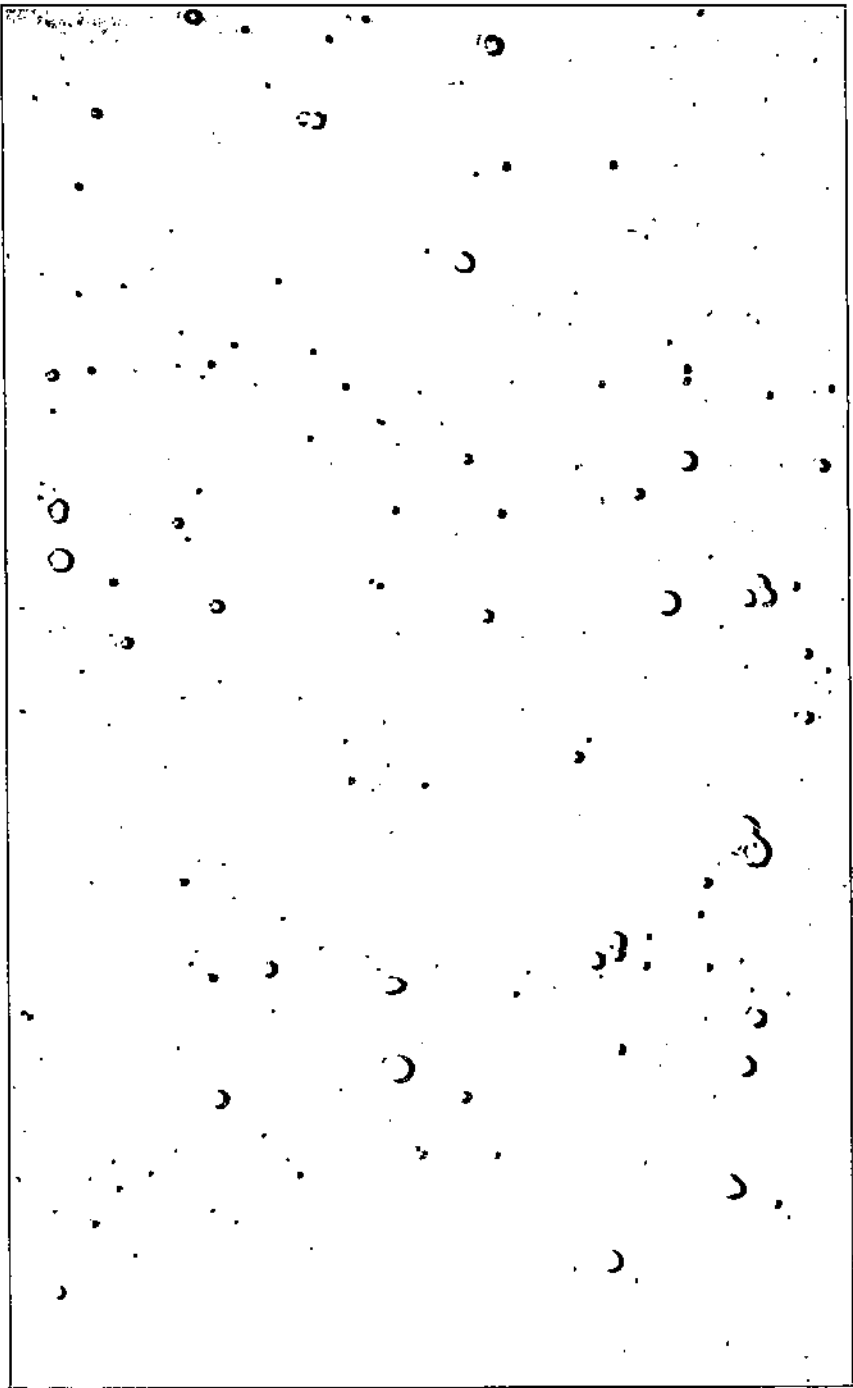

FAT GLOBULES IN FRESHLY PASTEURIZED 20 PER CENT CREAM. X 500

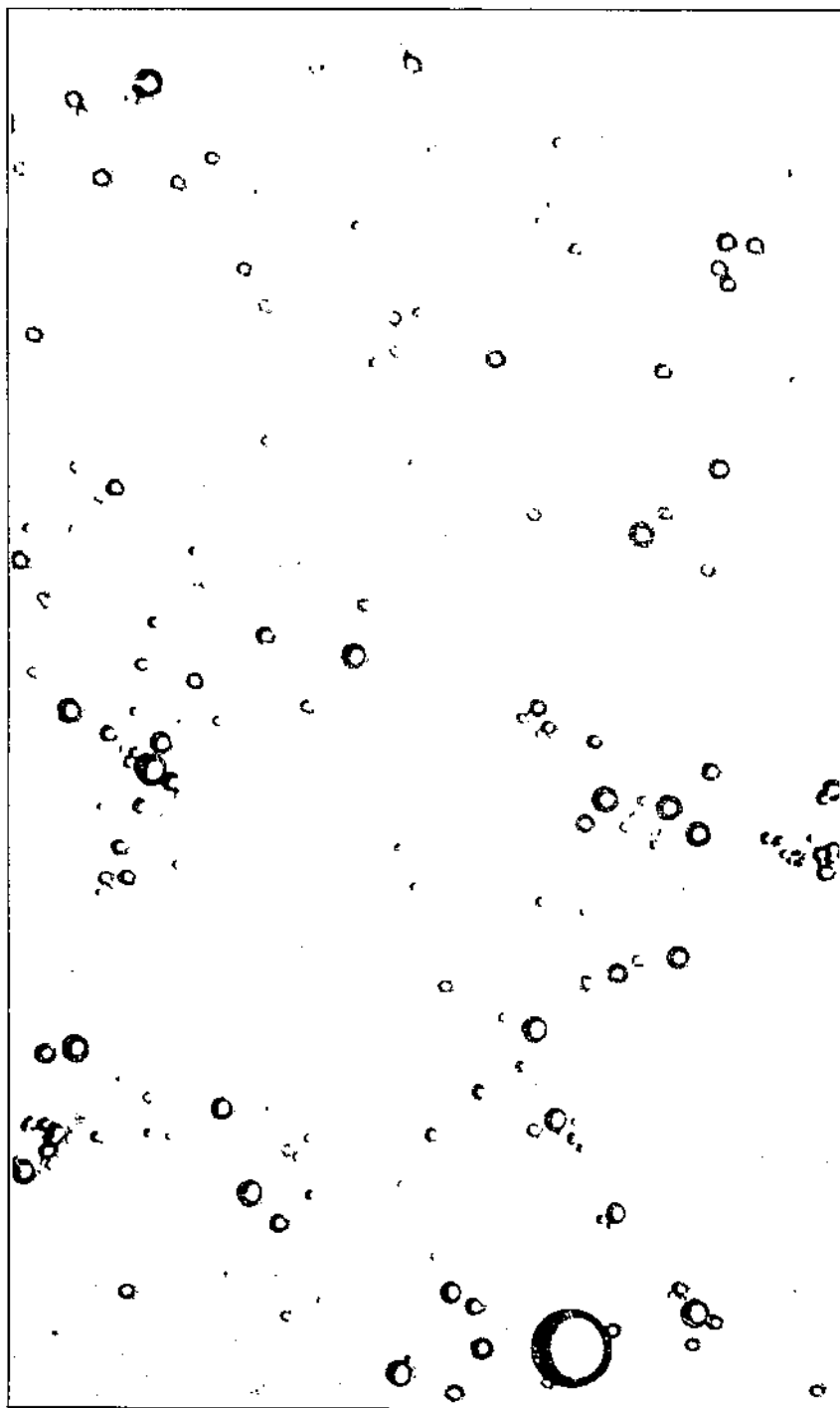

FAT GLOBULES IN 20 PER CENT PASTEURIZED CREAM AFTER AGING FOR 72 HOURS. \times 500

with a butterfat content of 20 per cent had practically the same viscosity when pasteurized at 80° C. as when pasteurized at 62.5°. The effect of the pasteurizing temperature was somewhat more pronounced with cream having a butterfat content of 30 per cent than with cream containing only 20 per cent butterfat. With 30 per cent cream, however, the difference in the viscosity of cream pasteurized at 80°, as compared with cream pasteurized at 62.5°, was too small to be of practical importance. (Table 4 and fig. 5.)

TABLE 4.—Effect of pasteurizing temperature upon the relative viscosity of cream

Pasteurizing temperature °C.	Butterfat	Relative viscosity					
		Fresh	At 3 hours	At 24 hours	At 48 hours	At 72 hours	At 96 hours
62.5	20	1.48	1.51	1.54	1.56	1.59	1.61
80	20	1.45	1.51	1.54	1.56	1.59	1.61
62.5	30	2.35	2.44	2.56	2.67	2.75	2.79
80	30	2.10	2.22	2.43	2.53	2.58	2.60

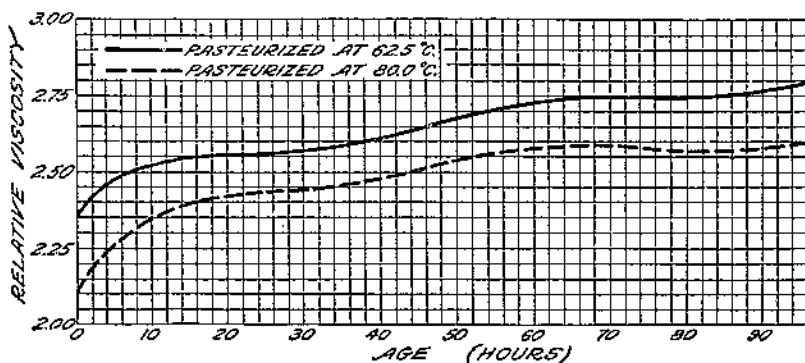

FIGURE 5.—Effect of pasteurizing temperature upon the viscosity of 30 per cent cream

GRAVITY-SEPARATED CREAM AND CENTRIFUGALLY SEPARATED CREAM COMPARED

The writer found gravity-separated cream to have a higher viscosity than centrifugally separated cream of the same butterfat content. The gravity cream was obtained by using a gravity-separation can 18 inches high and 8½ inches in diameter. The milk was held at a low temperature by placing the can in a large tank with sufficient ice and water around the can to extend above the height of the milk in the can. Samples of centrifugally separated cream and skim milk from the same mixed milk as was used in the separator can were suspended in the ice water, thus assuring the same storage conditions. The gravity-separated cream had an average butterfat content of 21.3 per cent. The centrifugally separated cream was standardized to the same butterfat content and the viscosity determinations were made 24 hours after the milk and cream were placed in the ice water.

Viscosity determinations at various temperatures (from 5° to 80° C.) showed the gravity-separated cream to have a slightly higher viscosity than centrifugally separated cream at the same temperatures. (Table 5 and fig. 6.) A microscopic study of the creams showed a greater degree of clumping of fat globules in the gravity-separated cream. This was probably due to the fact that the clumping of fat globules is closely associated with cream rising. The clumps thus formed during the 24-hour period of cream rising are more pronounced than those produced by centrifugal separation and subsequent aging for 24 hours.

TABLE 5.—Viscosity of gravity-separated cream as compared with centrifugally separated cream

Temperature (°C.)	Relative viscosity of—		Temperature (°C.)	Relative viscosity of—		Temperature (°C.)	Relative viscosity of—	
	Gravity cream	Separator cream		Gravity cream	Separator cream		Gravity cream	Separator cream
5	2.21	1.96	30	1.35	1.28	60	1.27	1.22
10	2.10	1.90	40	1.33	1.25	70	1.26	1.21
20	1.74	1.58	50	1.20	1.24	80	1.26	1.22

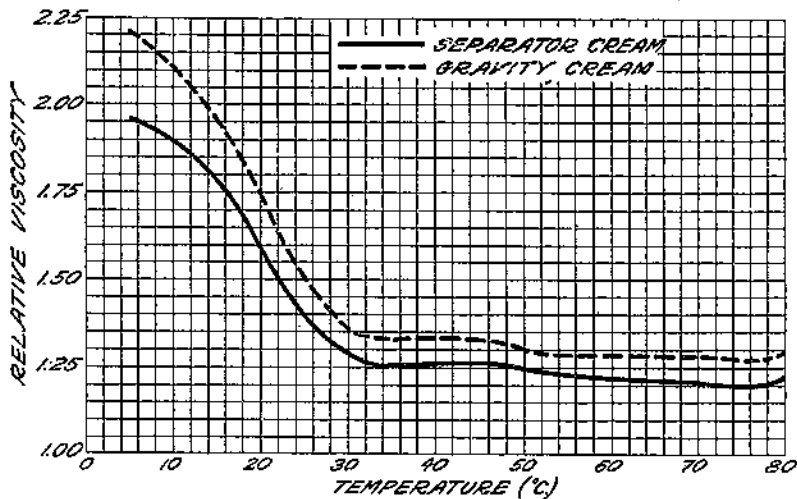

FIGURE 6.—Viscosity of gravity-separated cream as compared with centrifugally separated cream

EFFECT OF STANDARDIZATION

Standardizing cream to a specific butterfat content had practically no effect on viscosity, whether the cream was standardized from a higher to a lower, or from a lower to a higher butterfat content. (Table 6.) Cream with a butterfat content of 20 per cent had practically the same viscosity when prepared by standardizing with skim milk either cream which had an average butterfat content of 27.1 or 43.5 per cent. A mixture of milk and cream with an average butterfat content of 13 per cent standardized to 20 per cent

with cream having an average butterfat content of 34.7 per cent had a slightly higher viscosity than cream containing a higher butterfat content standardized to 20 per cent with skim milk. The difference in viscosity, however, was so small as to be of no practical importance. (Table 6.)

TABLE 6.—Effect of standardization upon the viscosity of 20 per cent cream

Preparation of cream		Relative viscosity at temperature of—									
Standardized from—	Standardized with—	5° C.	10° C.	20° C.	30° C.	40° C.	50° C.	60° C.	70° C.	80° C.	
27.1 per cent cream.....	Skim milk.....	1.78	1.60	1.44	1.30	1.28	1.25	1.24	1.23	1.23	
43.5 per cent cream.....	do.....	1.76	1.63	1.41	1.33	1.27	1.23	1.23	1.22	1.22	
33.0 per cent cream.....	34.7 per cent cream.....	1.82	1.70	1.49	1.42	1.32	1.29	1.27	1.26	1.26	

EFFECT OF FREEZING

Investigators agree that the effect of freezing upon normal cream is mainly that of destroying its physical structure, especially that of the fat system. A separation of free fat results and this becomes more marked with an increase in the fat concentration. Bateman and Sharp (5) found that frozen skim milk held for one day decreased in viscosity, but after it had aged in the frozen state for several days the viscosity increased to nearly that of the fresh sample.

In the work reported here the relative viscosity of cream with a fat content of 20 per cent was lowered 4.05 per cent by freezing. It was necessary to thaw the cream slowly and at a temperature just above the melting point of the fat, in order to prevent the flaking of protein and separation of free fat. Frozen cream with a fat content of 30 per cent could not be thawed without separation of fat to such an extent that accurate viscosity measurements were impossible. The viscosity of 20 per cent cream which had been frozen increased slightly upon aging. Aging for 96 hours increased the relative viscosity only 4.82 per cent (when the viscosity determinations were made at 5° C.) as compared with an increase of 30 per cent for similar cream which had not been frozen. Microscopic examination showed that regardless of age the fat globules remained separate and distinct, indicating that the ability of the globules to coalesce had been destroyed.

EFFECT OF ACIDITY

Increasing the acidity up to and including 0.3 per cent had practically no effect on the viscosity of 20 per cent raw cream. When the viscosity determinations were made at 5° C., an increase in acidity from an average of 0.202 per cent to an average of 0.254 per cent slightly increased the viscosity, but a further increase in acidity to an average of 0.3 per cent resulted in no additional increase in viscosity. When the determinations were made at 30°, increasing the acidity of the cream to 0.3 per cent had no effect on viscosity. At 62.5°, increasing the acidity to 0.254 per cent had no effect on viscosity, but a further increase in acidity to 0.3 per cent resulted in a slight increase in viscosity. (Table 7 and fig. 7.)

TABLE 7.—Effect of acidity upon the viscosity of 20 per cent raw cream

Acidity (per cent)	Relative viscosity at—		
	5° C.	30° C.	62.5° C.
0.202.....	2.01	1.31	1.22
.251.....	2.11	1.32	1.22
.300.....	2.12	1.32	1.27

It therefore appears that acidity up to and including 0.3 per cent has practically no effect upon the viscosity of normal cream. This is in agreement with results obtained by Doan (12), who reports that

changes in the acidity of the plasma had but little influence upon the clumping tendencies of fat exhibited in mixtures of normal milk and cream when homogenized.

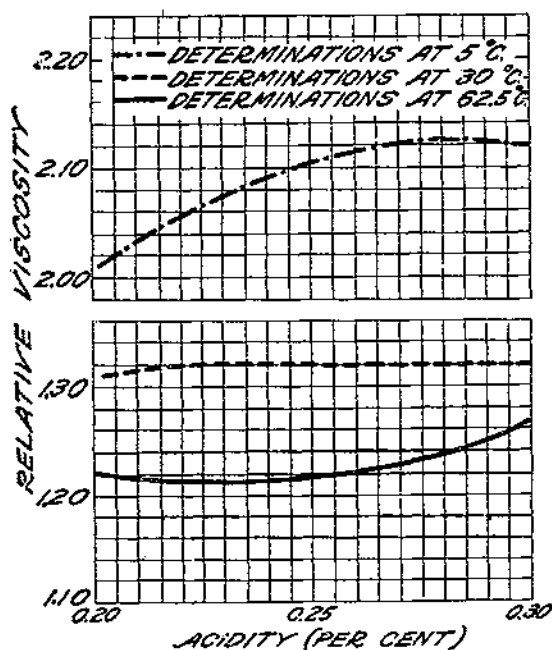

FIGURE 7.—Effect of acidity upon the viscosity of 20 per cent raw cream

with a surface cooler. Cream with a butterfat content of 30 per cent, which was cooled slowly, had a relative viscosity higher by 2.47 per cent and 1.82 per cent at 5° and 10°, respectively, than the rapidly cooled cream.

The slow cooling of pasteurized cream from a pasteurizing temperature of 62.5° to a temperature of 5° C. had a more pronounced effect on viscosity than did the slow cooling of raw cream. Pasteurized cream with a butterfat content of 20 per cent, when cooled slowly, had a relative viscosity 3.13 per cent higher at 5° C. and 2 per cent higher at 10° than similar cream cooled rapidly. Pasteurized cream with a butterfat content of 30 per cent, when cooled slowly, had a relative viscosity higher by 5.18 per cent and 3.5 per cent at 5° and 10°, respectively, than had similar cream when cooled rapidly.

EFFECT OF COOLING

The viscosity of cream is affected by the rate of cooling. When raw cream with a butterfat content of 20 per cent was permitted to cool slowly, by packing in ice, from a separating temperature of 26° to 5° C., the relative viscosity was 1.71 per cent higher at 5° and 1.82 per cent higher at 10° than the viscosities obtained at these temperatures for similar cream cooled rapidly

Pasteurized cream with a butterfat content of 30 per cent, when cooled slowly from a pasteurizing temperature of 62.5° to 45° C. and then cooled rapidly to 5°, had a relative viscosity 1.21 per cent higher at 5° and 0.84 per cent higher at 10° than when the cream was cooled rapidly from the pasteurizing temperature to 5°. When the cream was cooled slowly to 30° and then rapidly to 5°, its relative viscosity was 3.93 per cent and 2.68 per cent greater at 5° and 10°, respectively, than when the cream was cooled rapidly.

The cooling of fresh raw cream just before pasteurizing had practically no effect on the relative viscosity of the pasteurized cream. Cream with a butterfat content of 30 per cent cooled to 5° C. before pasteurizing had a relative viscosity only 0.39 per cent greater at 5° and only 0.89 per cent greater at 10° than similar cream not cooled below the separating temperature before pasteurizing.

These results indicate that where cream with a high viscosity is desirable the better method is to cool the cream slowly. This applies to the cooling of raw cream and to an even greater extent to the cooling of pasteurized cream. In the case of pasteurized cream, partial cooling at a slow rate followed by rapid cooling also increases the viscosity as compared to rapid cooling. Whittaker, Archibald, Shere, and Clement (21) found that milk cooled in tank or vat pasteurizers from the pasteurizing temperature to 10° C. showed a small cream volume. Cooling milk in the tank or vat to approximately 45° and then cooling it quickly to below 10° over a separate cooler resulted in a large cream volume. The small cream volume on the milk which was cooled slowly may have been due to the amount of agitation necessary to prevent the formation of a cream layer during the cooling period. In the experiments reported here, cream which was cooled slowly was not agitated while cooling.

A microscopic study of the cream showed that the fat globules were clumped to a greater extent in cream which was cooled slowly than in cream which was cooled rapidly. The increase in relative viscosity due to cooling the cream slowly to 45° C. indicates that the clumping of fat globules takes place, at least to a slight degree, above this temperature. The greater increase in relative viscosity with slow cooling to a lower temperature also indicates that clumping takes place to a more marked degree at temperatures below 45°. The rapid cooling does not allow enough time for the fat globules to clump to a marked degree, and the sudden cooling to a low temperature apparently has a tendency to harden the globules and to destroy their ability to coalesce.

EFFECT OF SEPARATING TEMPERATURE

Dahlberg and Hening (8) demonstrated that the viscosity of cream of any percentage of fat could be greatly altered by the condition of the fat at the time of separation. The writer's work showed that the viscosity of cream is affected by the temperature at which the cream is separated. Raw cream with a butterfat content of 30 per cent, separated from milk at 18° C., had a relative viscosity 14.45 per cent higher at 5°, and 10.24 per cent higher at 10° than cream at these temperatures which had been separated from similar milk at 36°.

EFFECT OF STORAGE OF MILK

The viscosity of raw cream is affected by the time and temperature of storage of the milk before separation. Raw cream with a butterfat content of 30 per cent, separated from milk which had been stored three hours at 4° C. had a relative viscosity 14.16 per cent higher at 5°, and 12.23 per cent higher at 10° than cream which was separated from similar milk stored at 18° for three hours. When the milk was stored for 12 hours before separation, the cream from that stored at 4° C. had a relative viscosity 12.2 per cent and 9.65 per cent higher at 5° and 10°, respectively, than cream from the milk stored at 18°.

When the milk was stored at 4° C., increasing the time of storage before separation from 3 hours to 12 hours increased the relative viscosity of the cream 4.96 per cent at 5°, and 2.17 per cent at 10°. When the storage temperature was 18°, increasing the time of storage from 3 hours to 12 hours increased the relative viscosity of the cream 6.8 per cent and 4.28 per cent at 5° and 10°, respectively.

The increase in viscosity of raw cream due to storage conditions was not entirely lost when the cream was pasteurized. Pasteurized cream with a butterfat content of 30 per cent from milk which had been stored at 4° C. for 12 hours had a relative viscosity 3.52 per cent higher at 5°, and 3.22 per cent higher at 10° than when the cream was obtained from similar milk stored at 18° for 12 hours. The decrease in relative viscosity due to pasteurization was 44.44 per cent at 5°, and 40.26 per cent at 10° for the cream separated from milk which had been stored for 12 hours at 4°, as compared with 39.79 per cent and 36.55 per cent at 5° and 10°, respectively, for the cream separated from milk which was stored for 12 hours at 18°.

Therefore it appears that one of the best methods to increase the viscosity of cream is to store the milk at a low temperature for at least 12 hours before separation. This is in accord with the work of Dahlberg and Hening (8), who found that it was possible, by controlling the extent of fat clumping before separation, to produce raw cream that resembled ordinary pasteurized cream, or to produce raw cream that had about 10 times the viscosity that ordinary pasteurized cream has after aging. They further found that it was possible to produce cream from pasteurized milk that resembled very viscous raw cream. Pyne and Lyons (15) obtained the same or better results by storing cream at a low temperature and then reseparatoring it.

EFFECT OF PASTEURIZING BEFORE SEPARATING

The effect that pasteurizing milk before it is separated has upon the viscosity of the cream depends upon the manner of handling the pasteurized milk. Cream with a butterfat content of 30 per cent from milk pasteurized and separated without cooling had a relative viscosity, at 24 hours of age, 8.85 per cent lower at 5° C., and 9.24 per cent lower at 10° than similar cream separated from similar milk at 26° and pasteurized after being separated. After aging for 48 hours, the cream from the milk pasteurized before being separated had a relative viscosity 9.56 per cent and 8.06 per cent lower at 5° and 10°, respectively, than the cream pasteurized after it was separated.

Cream with a butterfat content of 30 per cent from milk pasteurized and rapidly cooled (by use of a surface cooler) to a separating tem-

perature of 26° C. had a relative viscosity at 24 hours of age 4.63 per cent lower at 5° and 4.24 per cent lower at 10° than cream separated from similar milk but pasteurized after being separated. After aging for 48 hours, the cream from the milk pasteurized before being separated had a relative viscosity 4.07 per cent and 3.66 per cent lower at 5° and 10°, respectively, than the cream pasteurized after it was separated.

Cream with a butterfat content of 30 per cent separated from milk pasteurized and cooled slowly (with cold water) in the vat before it was separated, to a separating temperature of 26° C. had a relative viscosity at 24 hours of age 5.75 per cent greater at 5°, and 7.56 per cent greater at 10° than cream separated from similar milk and pasteurized after it was separated. After aging for 48 hours the cream from milk pasteurized before it was separated had a relative viscosity 5.2 per cent and 6.07 per cent greater at 5° and 10°, respectively, than the cream pasteurized after it was separated.

These results indicate that when milk is separated after pasteurization and a cream with good viscosity is desired, the milk should be cooled slowly with minimum agitation to the separating temperature. However, Dahlberg and Hening (8) have shown that cream of great viscosity can not be produced without giving the fat time to harden after pasteurization and before the milk is separated.

EFFECT OF HOMOGENIZATION

Homogenization increases the viscosity of cream. When cream with a butterfat content of 20 per cent was homogenized its viscosity was increased. The increase in viscosity was in direct relation to the pressure used for homogenization. (Table 8 and fig. 8.) Burgwald (6) and Webb and Holm (19) found that the feathering of cream is affected to a considerable extent by homogenization. Therefore when cream is homogenized for the purpose of increasing its viscosity, especially if the cream is to be used as coffee cream, care should be taken that the increase in viscosity is not obtained at the expense of increasing the feathering.

TABLE 8.—Effect of homogenization upon the viscosity of cream with a butterfat content of 20 per cent at 20° C.

Homogenizing pressure (pounds per square inch)	Relative viscosity of cream pasteurized and homogenized at—		Homogenizing pressure (pounds per square inch)	Relative viscosity of cream pasteurized and homogenized at—	
	62.5° C.	70° C.		62.5° C.	70° C.
0.....	1.34	1.37	2,000.....	2.07	1.60
500.....	1.41	1.30	2,500.....	2.26	1.60
1,000.....	1.50	1.47	3,000.....	2.70	1.73
1,500.....	1.77	1.55			

Doan (11), Mortensen (14), Mortensen, as reported by Curtiss (7), Evenson and Ferris (13), Dahle and Martin (9), Reid and Moseley (16), and others have called attention to the fact that homogenization of cream and of ice-cream mixes causes not only a subdivision of the fat globules but also their aggregation into clumps.

In a microscopic study of homogenized cream made by the writer, homogenizing at a pressure of 500 pounds per square inch not only broke up the individual fat globules but caused a wide dispersion of the newly formed globules. When the pressure was increased to 1,000 pounds per square inch the fat globules were broken up to a greater extent, and many of the dispersed globules were brought together into small clumps, most of which consisted of two to four globules. As the pressure increased the clumps increased in size, and the number and size of the individual globules became smaller.

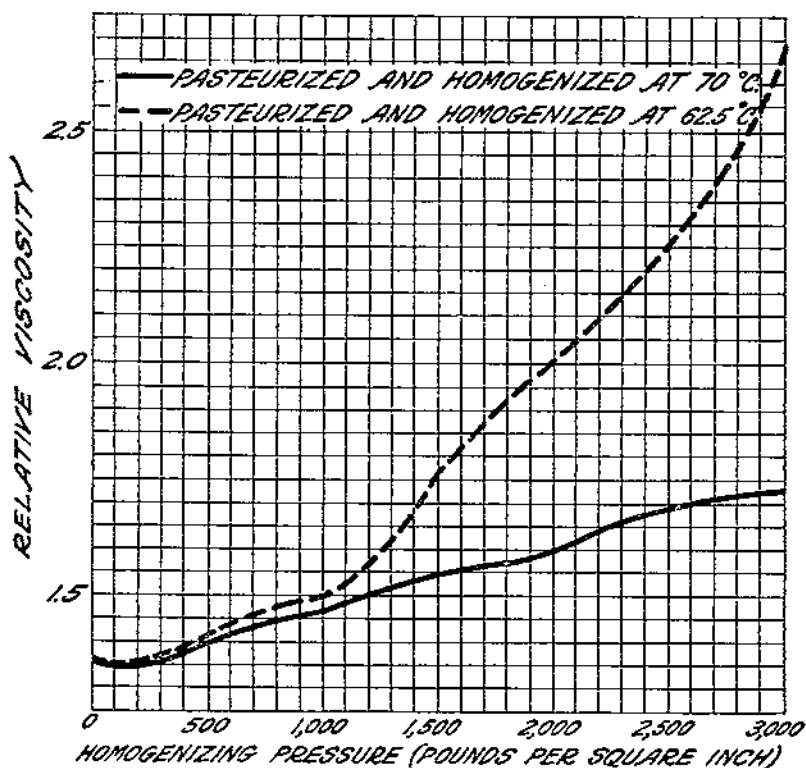
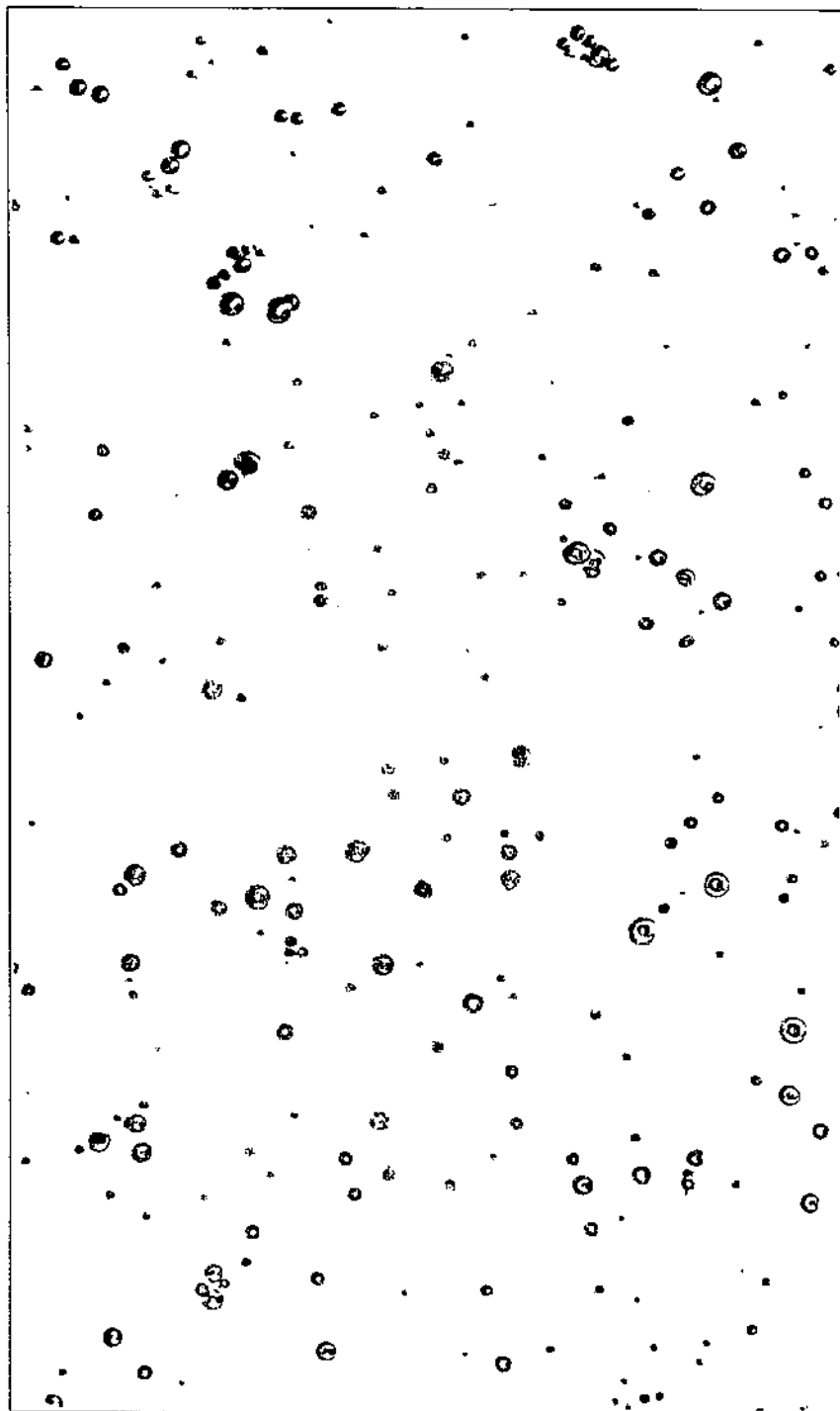

FIGURE 8.—Effect of homogenization upon the viscosity of pasteurized cream with a butterfat content of 20 per cent

At about 2,500 pounds pressure the clumps reached maximum size. Increasing the pressure above this point had a tendency not only to diminish the number of individual globules but also to break up the larger clumps into smaller ones, and when 4,000 pounds pressure was applied a large percentage of the globules were in dense, medium-sized clumps. (Pls. 5 to 10, inclusive.)

EFFECT OF HOMOGENIZING TEMPERATURE

The temperature at which cream is homogenized affects its viscosity. When pasteurized cream with a butterfat content of 20 per cent



FAT GLOBULES IN 20 PER CENT CREAM PASTEURIZED AT 62.5 C. X 500

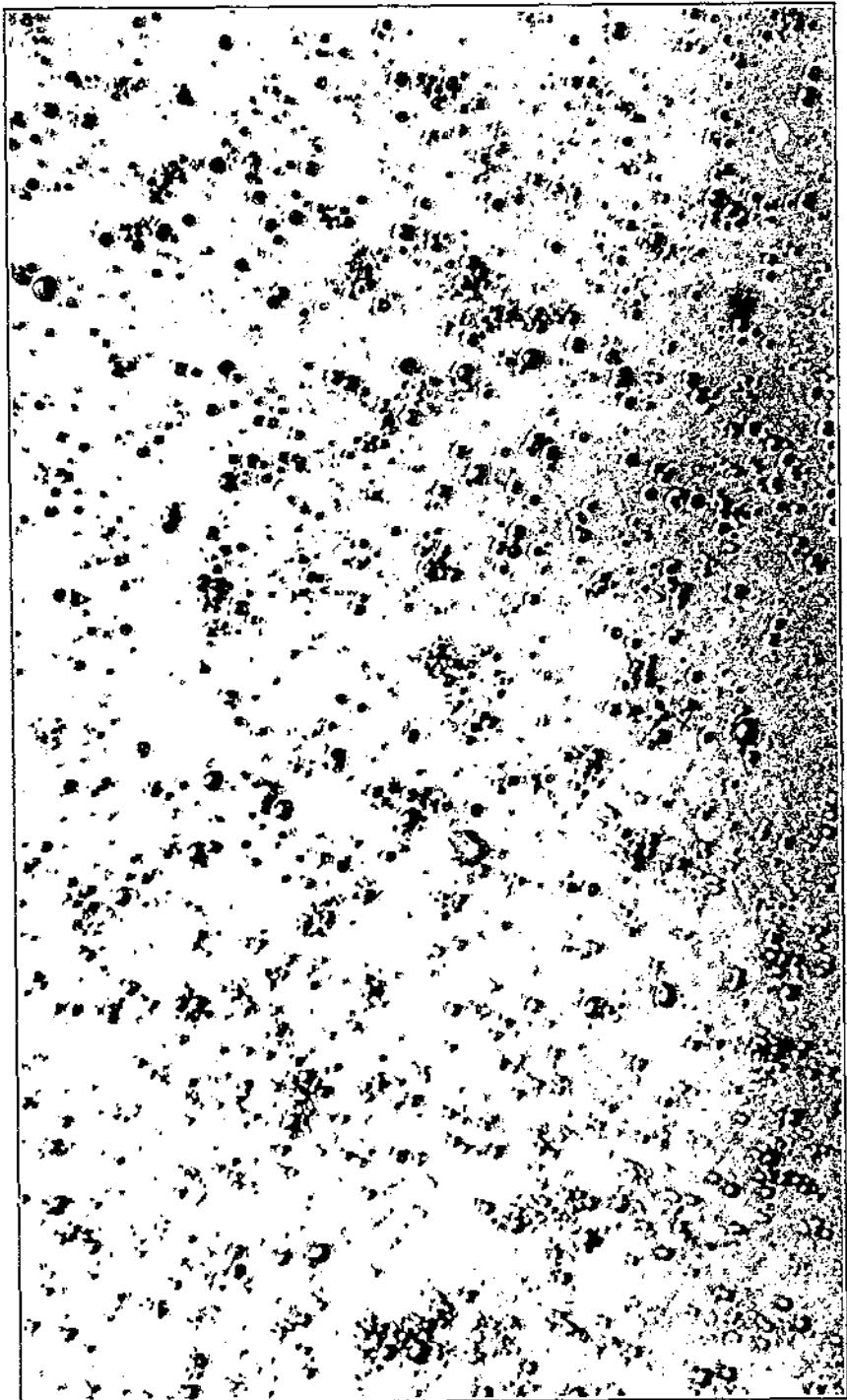

SAME CREAM AS IN PLATE 5. HOMOGENIZED AT 500 POUNDS PRESSURE PER SQUARE INCH, AT 62.5° C. X 500

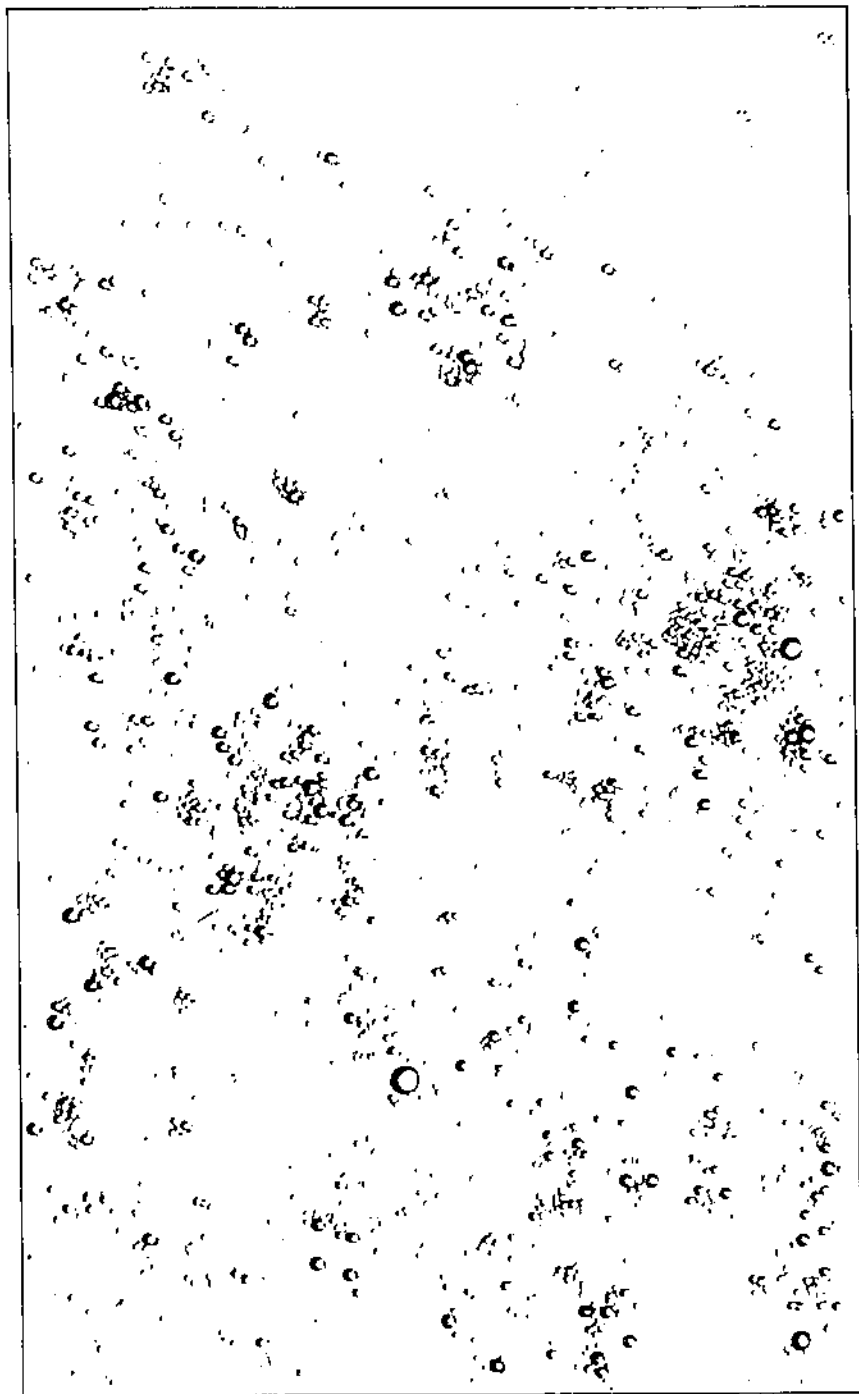

SAME CREAM AS IN PLATE 5, HOMOGENIZED AT 1,000 POUNDS PRESSURE PER SQUARE INCH, AT 62.5° C. X 500

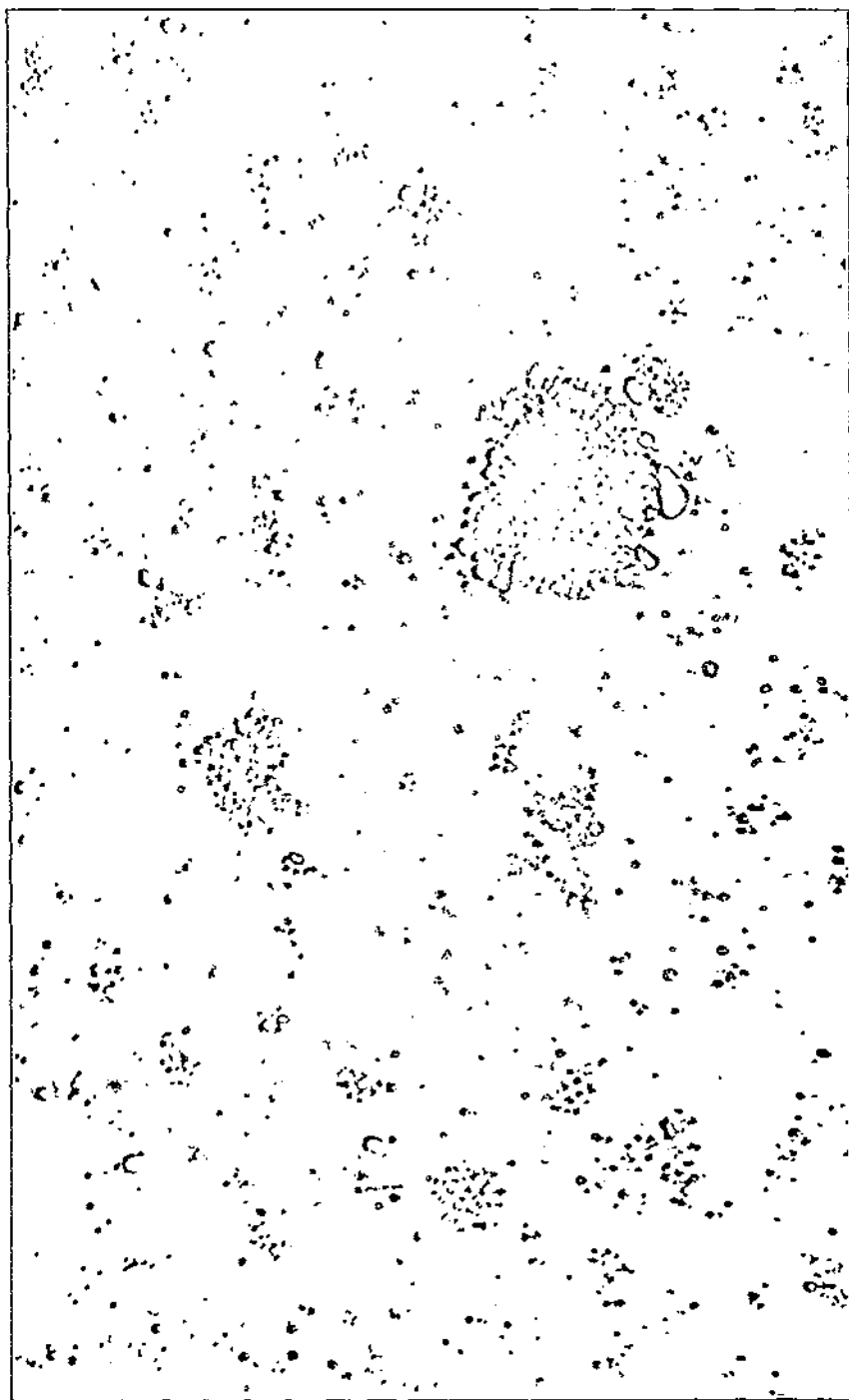

SAME CREAM AS IN PLATE 5, HOMOGENIZED AT 2,000 POUNDS PRESSURE PER SQUARE INCH. AT 52.5° C. X 500

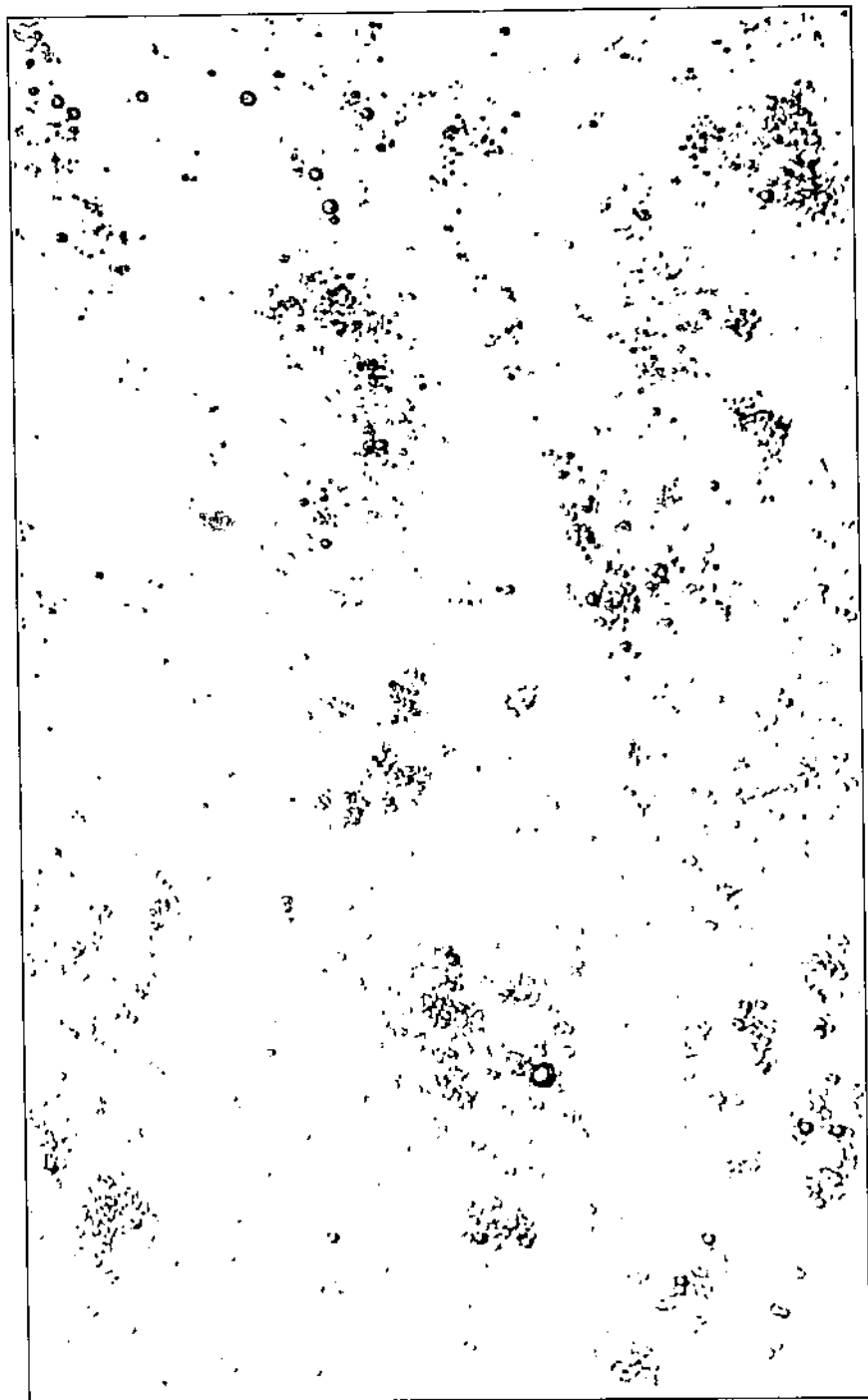

SAML CREAM AS IN PLATE 5. HOMOGENIZED AT 3,000 POUNDS PRESSURE PER SQUARE INCH, AT 62.5 C. X 500

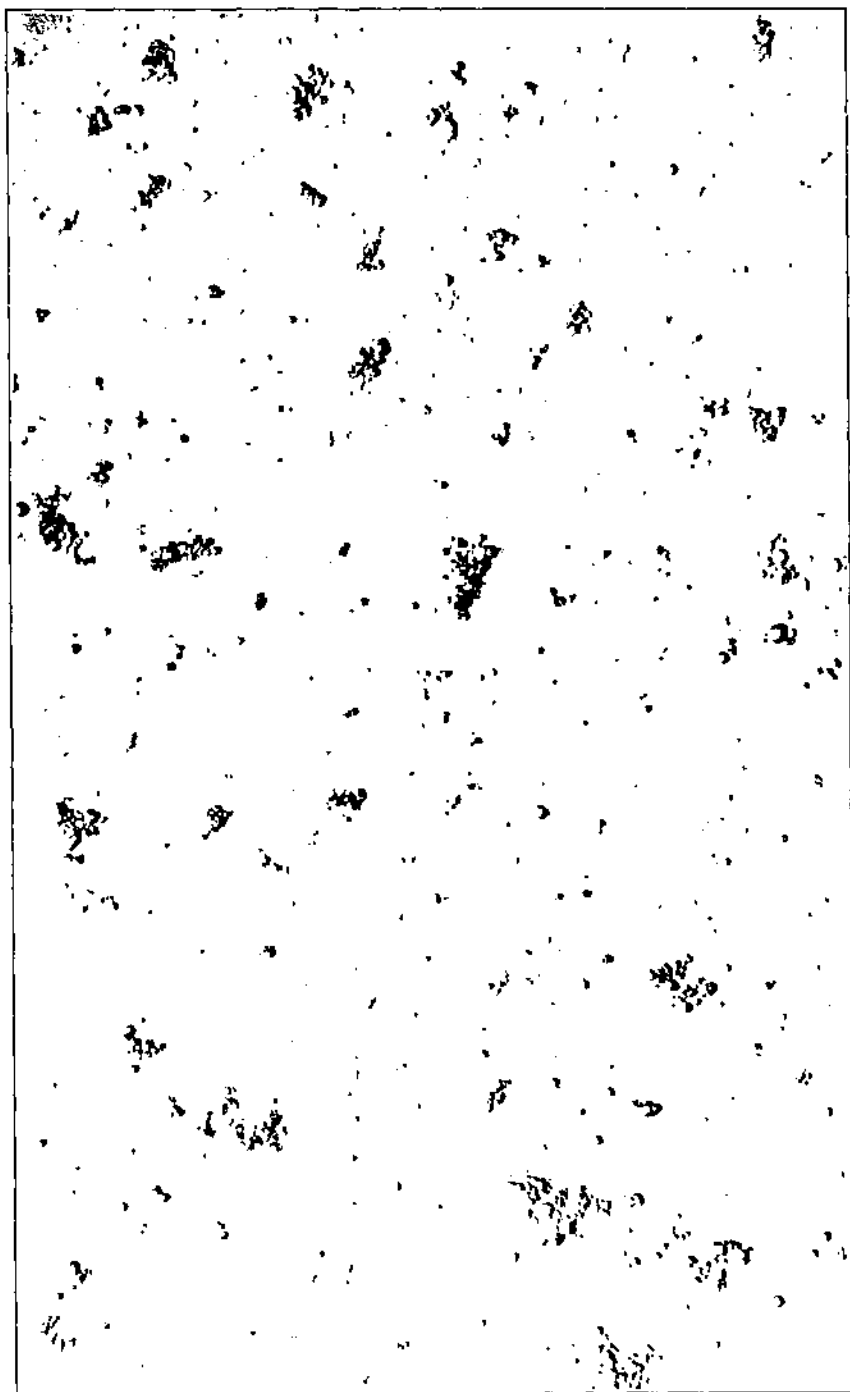

SAME CREAM AS IN PLATE 5. HOMOGENIZED AT 4,000 POUNDS PRESSURE PER SQUARE INCH. AT 62.5° C. X 500

was homogenized at a constant pressure, but at temperatures varying from 50° to 88° C., its relative viscosity varied with the temperature. The lower the temperature at which the cream was homogenized, the higher was the viscosity. When different samples of the cream were pasteurized at the same temperatures as those at which they were homogenized, as the temperature was increased the relative viscosity decreased until it was at its minimum at 70°, and then increased with a further rise in the homogenizing temperature. When the cream was pasteurized at a constant temperature of either 62.5° or 80° and the homogenizing temperature was varied, the maximum viscosity in both cases was obtained at the lowest homogenizing temperature. However, the higher pasteurizing temperature, 80°, gave a lower maximum viscosity than did the lower temperature, 62.5°. This indicates that the relative viscosity of homogenized cream is slightly affected by the temperature at which it was pasteurized. For the constant pasteurizing temperatures used, the homogenizing temperature at which the lowest viscosity resulted ranged from 70° to 80°. Raising the temperature of homogenization to 88° increased the relative viscosity above the minimum. (Table 9 and fig. 9.)

TABLE 9.—Effect of homogenizing temperature upon the viscosity of pasteurized cream with a butterfat content of 20 per cent

Homogenizing temperature (°C.)	Relative viscosity of—			
	Cream pasteurized at homogenizing temperature; homogenized at 3,000 pounds	Cream pasteurized at homogenizing temperature; homogenized at 2,000 pounds	Cream pasteurized at 62.5° C.; homogenized at 2,000 pounds	Cream pasteurized at 80° C.; homogenized at 2,000 pounds
50.....	4.6	3.3	3.2	2.9
62.5.....	3.6	2.6	2.6	2.4
70.....	2.1	1.6	2.0	2.0
80.....	2.3	1.8	1.7	1.8
88.....	3.1	2.1	1.9	2.0

In determining the temperature at which cream should be homogenized, the fact that the stability of homogenized cream is in indirect proportion to its viscosity, as has been reported by Webb and Holm (19), should not be overlooked.

In the present work a microscopic study of cream homogenized at different temperatures from 50° to 88° C. showed that the clumping of the fat globules was affected by the temperature of homogenization. The greater degree of clumping took place at the lower homogenizing temperatures. With rise in temperature the degree of clumping diminished until the point was reached where the viscosity was the lowest, and at this point the fat globules were widely dispersed, but with further rise in temperature the degree of clumping increased. (Pls. 11 to 15, inclusive.)

EFFECT OF REHOMOGENIZATION

The viscosity of homogenized cream is lowered by rehomogenization. The relative viscosity of cream with a butterfat content of 20 per cent, homogenized at a temperature of 62° C. and a pressure of 2,000 pounds was lowered 18.42 per cent by rehomogenization at the same temperature and pressure.

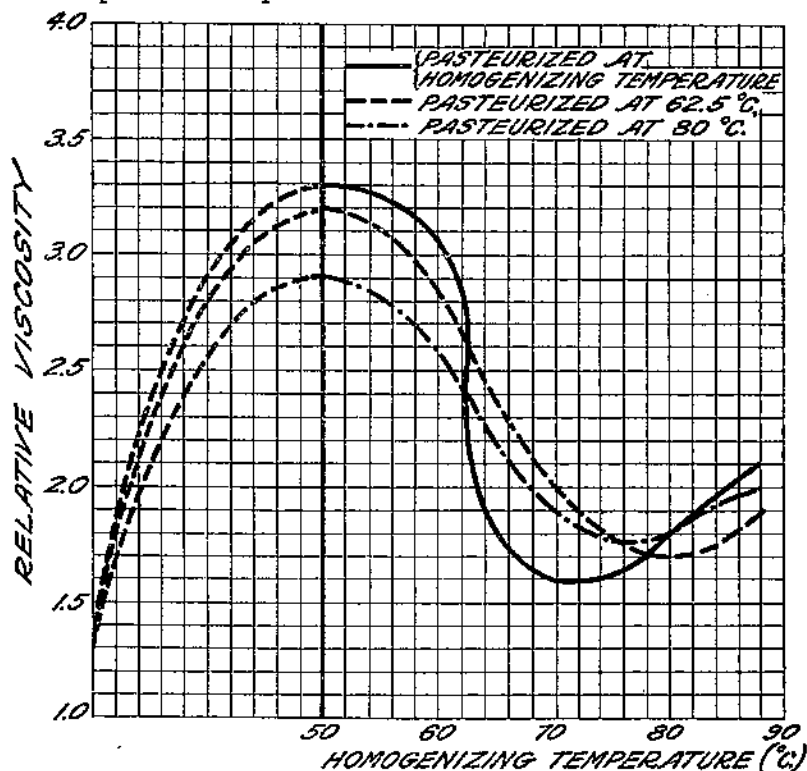

FIGURE 2.—Effect of homogenizing temperature upon the viscosity of 20 per cent cream homogenized at 2,000 pounds per square inch

A microscopic study of the fat globules in the processed creams showed that upon rehomogenization of the cream many of the clumps due to homogenizing were broken up when the cream was homogenized a second time. (Pls. 16 and 17.)

EFFECT OF SOLIDS NOT FAT

Dahlberg and Hening (8) found that small variations in the milk solids not fat in cream did not materially affect viscosity. Doan (12), however, reported that the ratio of the amount of plasma solids to the amount of fat in the mixtures processed is a limiting factor in the fat-clumping phenomenon.

The work of the writer indicates that the viscosity of cream is affected by the percentage of solids not fat present. When cream with a butterfat content of 36 per cent was standardized to a butterfat content of 20.5 per cent with skim milk, water, or evaporated skim milk, so as to vary the percentage of solids not fat, the viscosity of the cream also varied. The lower the percentage of solids

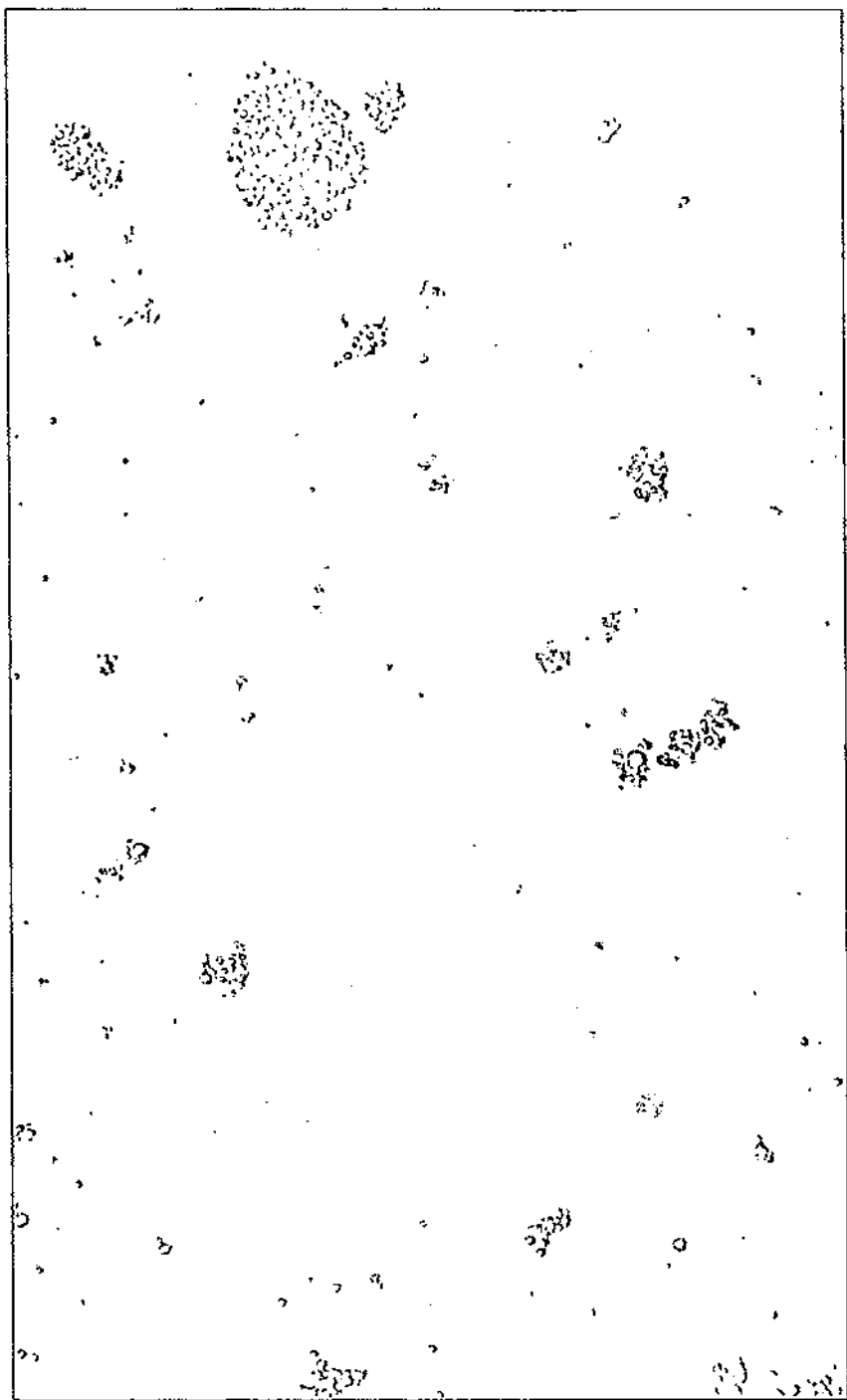

TWENTY PER CENT CREAM PASTEURIZED AT 50° C. AND HOMOGENIZED AT 3,000 POUNDS PRESSURE PER SQUARE INCH AT 50° C. X 500

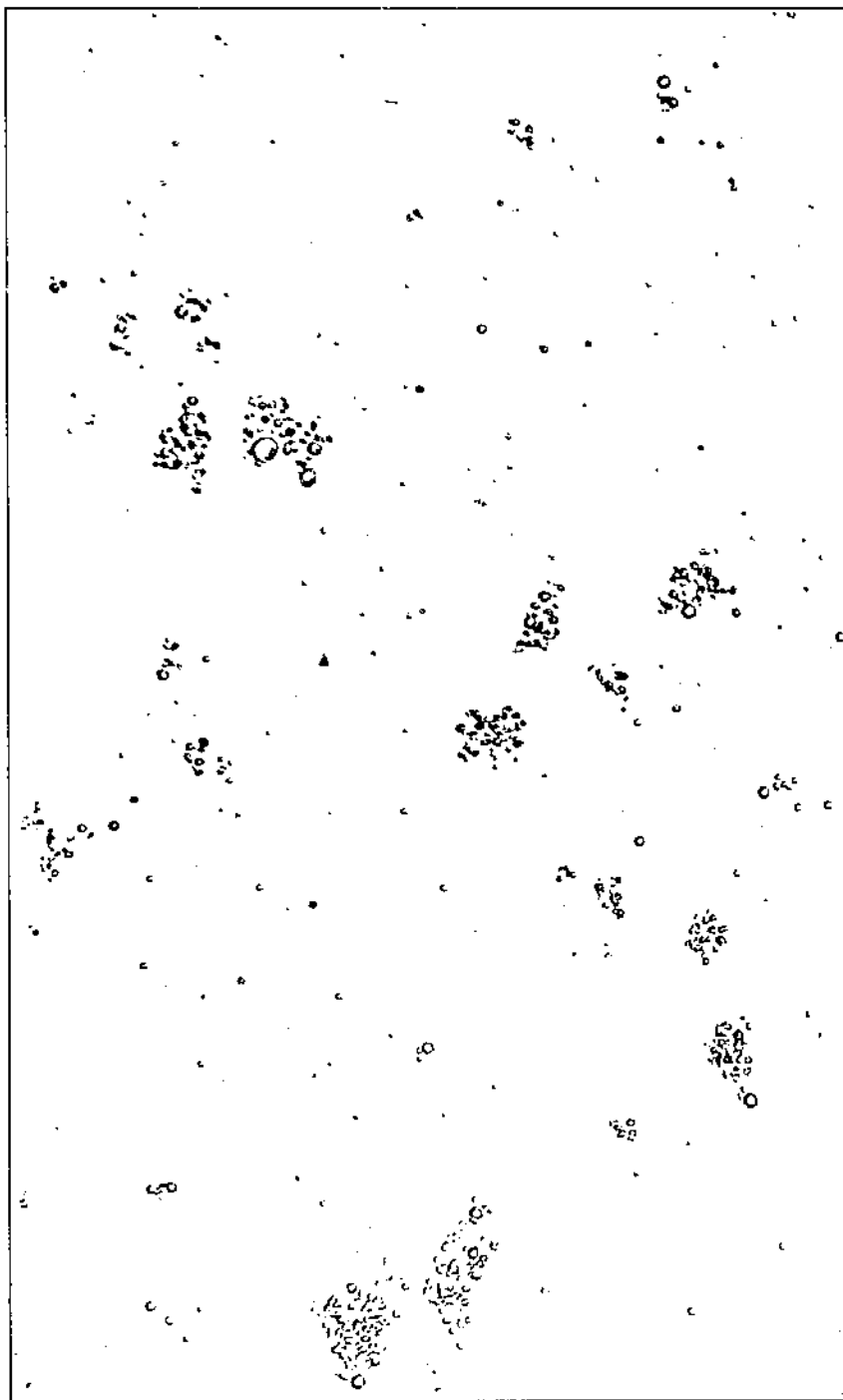

TWENTY PER CENT CREAM PASTEURIZED AT 62.5° C. AND HOMOGENIZED AT 3,000 POUNDS PRESSURE PER SQUARE INCH AT 62.5° C. X 500

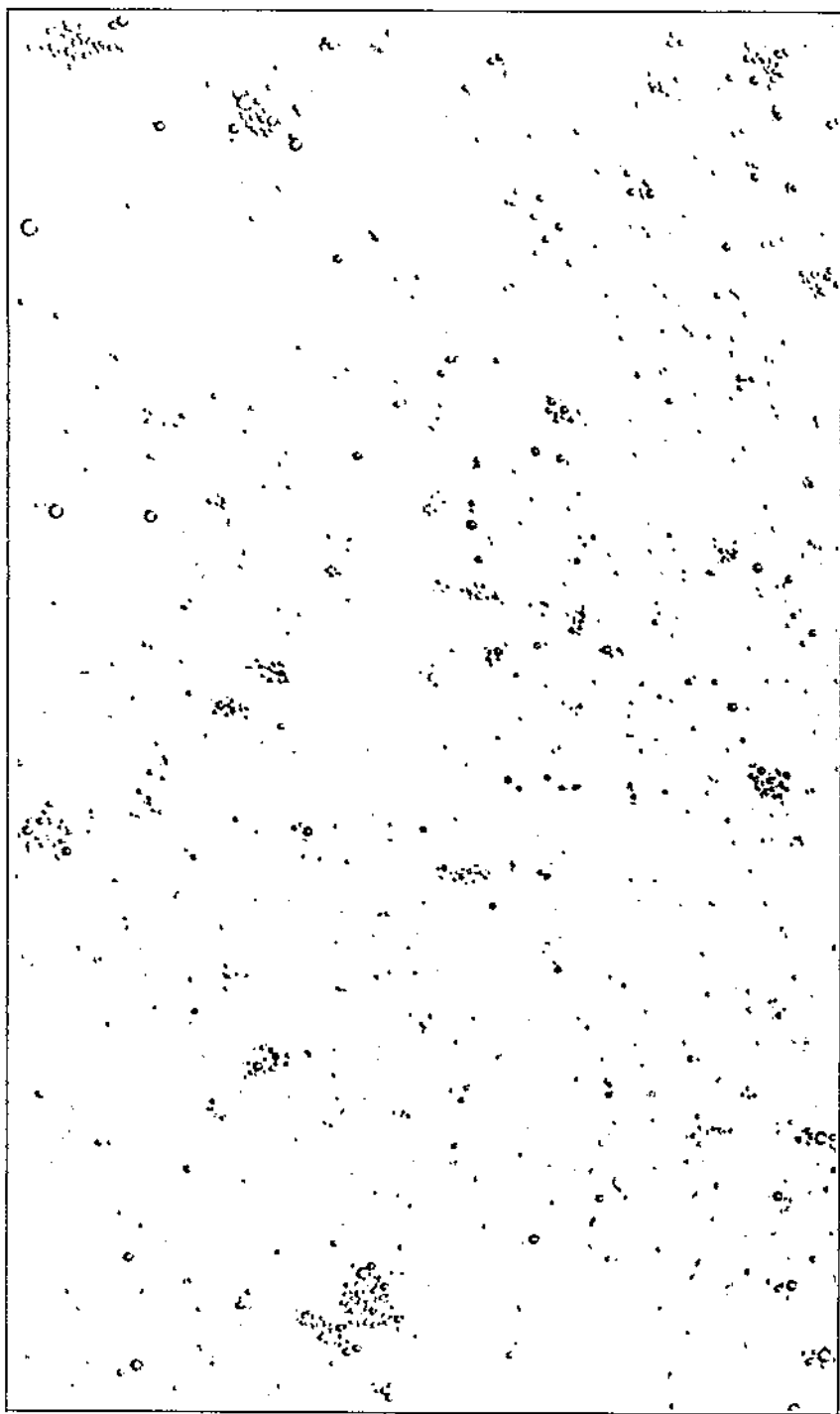

TWENTY PER CENT CREAM PASTEURIZED AT 70° C. AND HOMOGENIZED AT 3,000 POUNDS PRESSURE PER SQUARE INCH AT 70° C. X 500

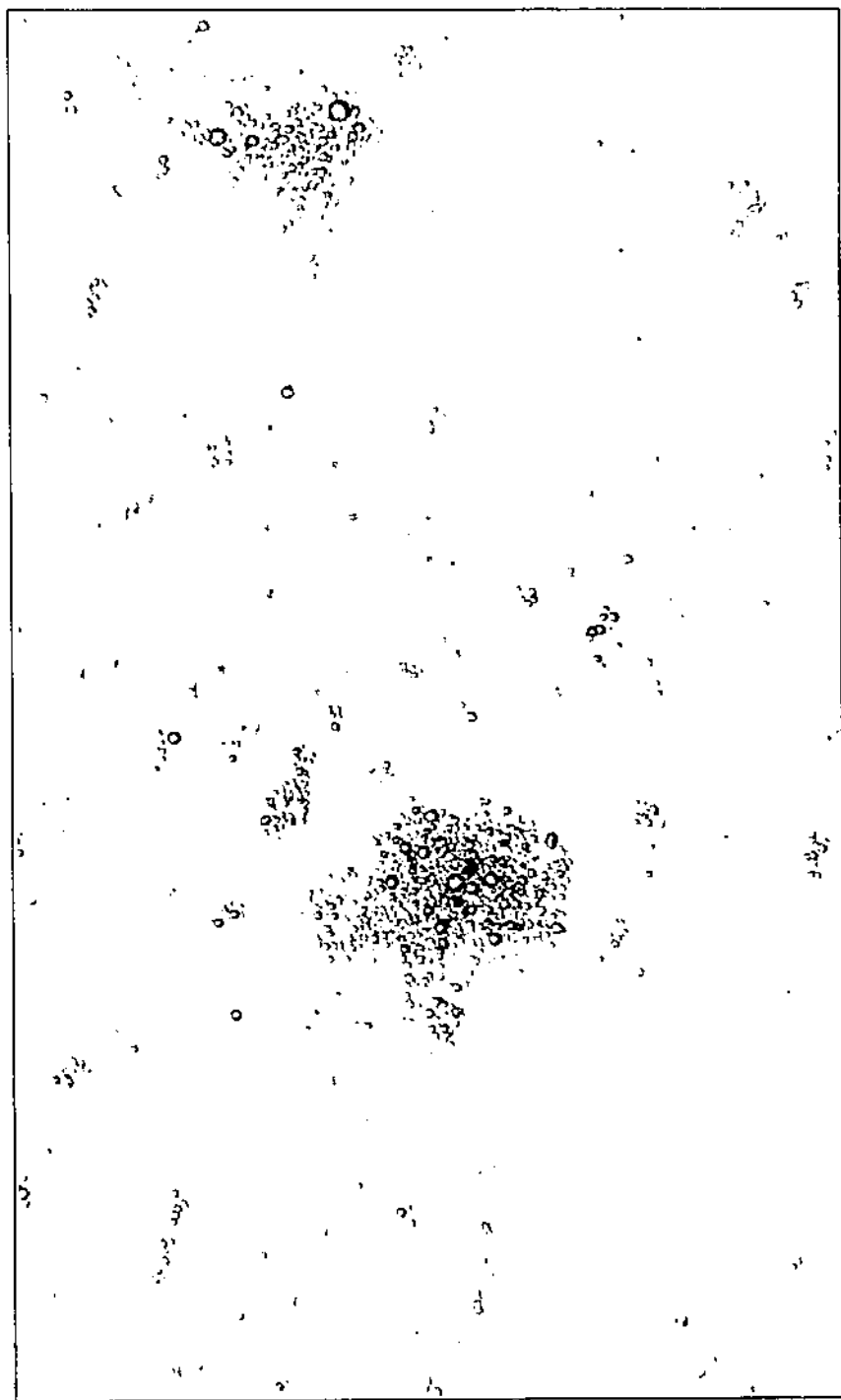

TWENTY PER CENT CREAM PASTEURIZED AT 80° C. AND HOMOGENIZED AT 3,000 POUNDS PRESSURE PER SQUARE INCH AT 80° C. X 500

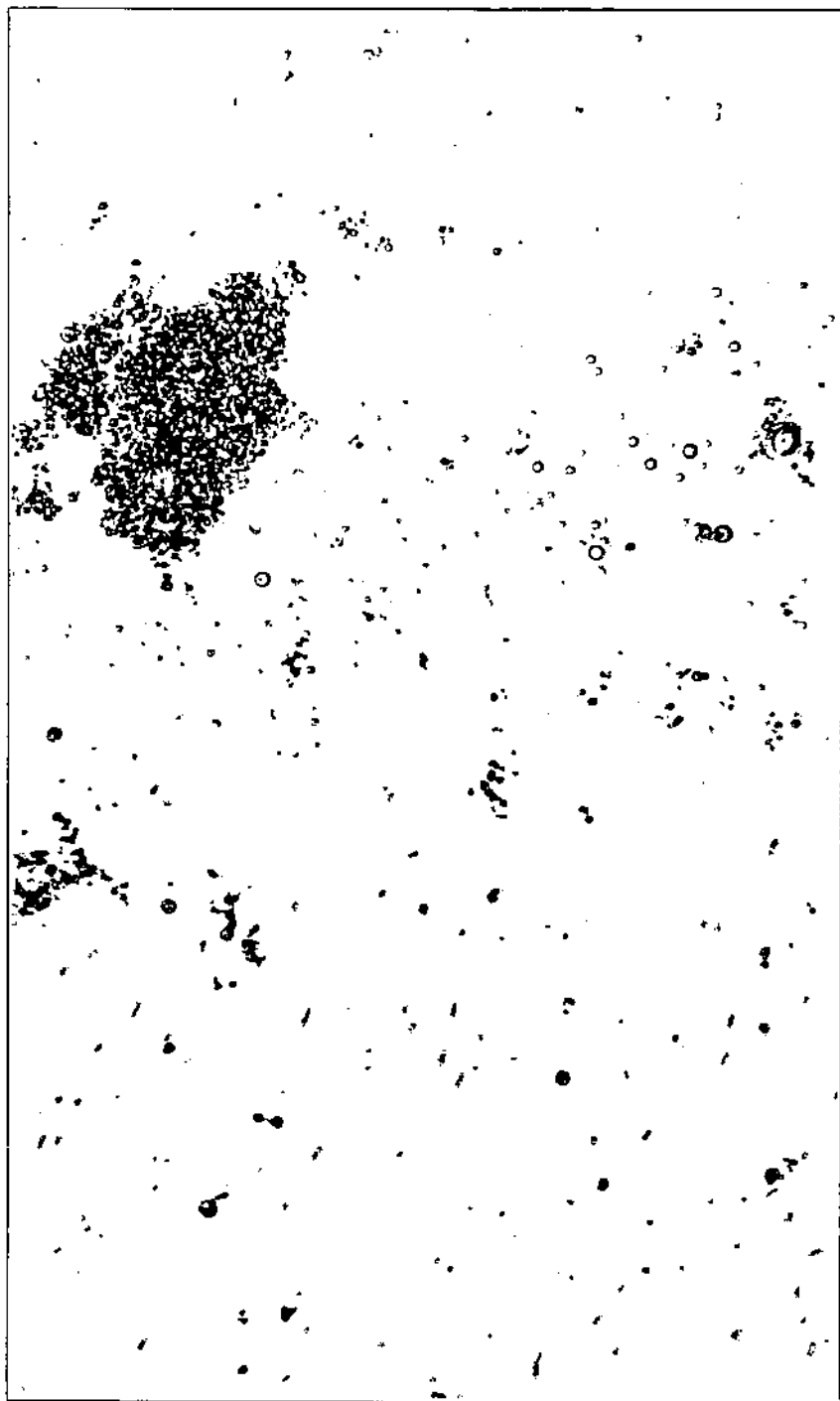

TWENTY PER CENT CREAM PASTEURIZED AT 88° C. AND HOMOGENIZED AT 3,000 POUNDS PRESSURE PER SQUARE INCH AT 88° C. X 500

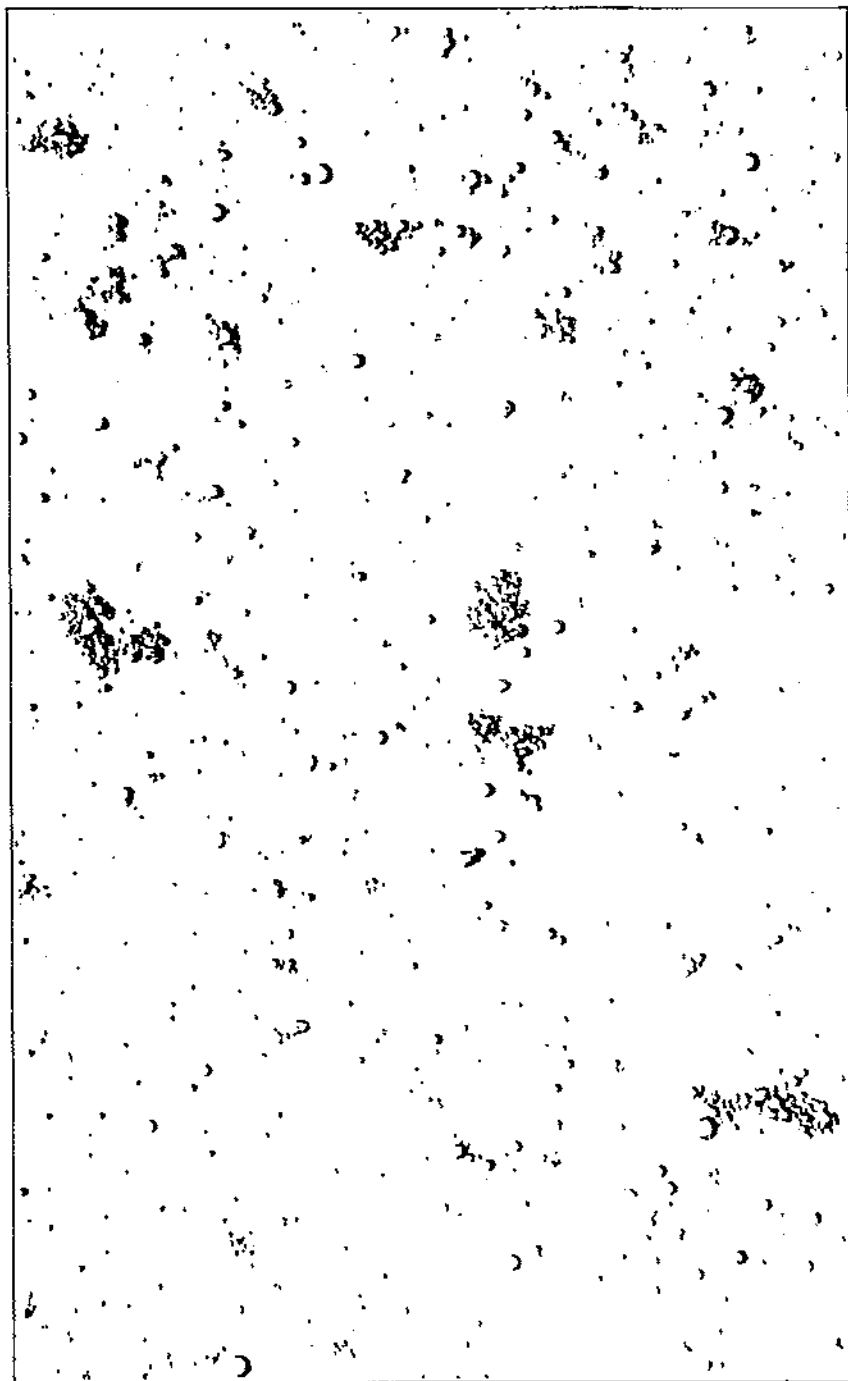

TWENTY PER CENT CREAM HOMOGENIZED AT 2,000 POUNDS PRESSURE PER SQUARE INCH AT 62° C. X 500

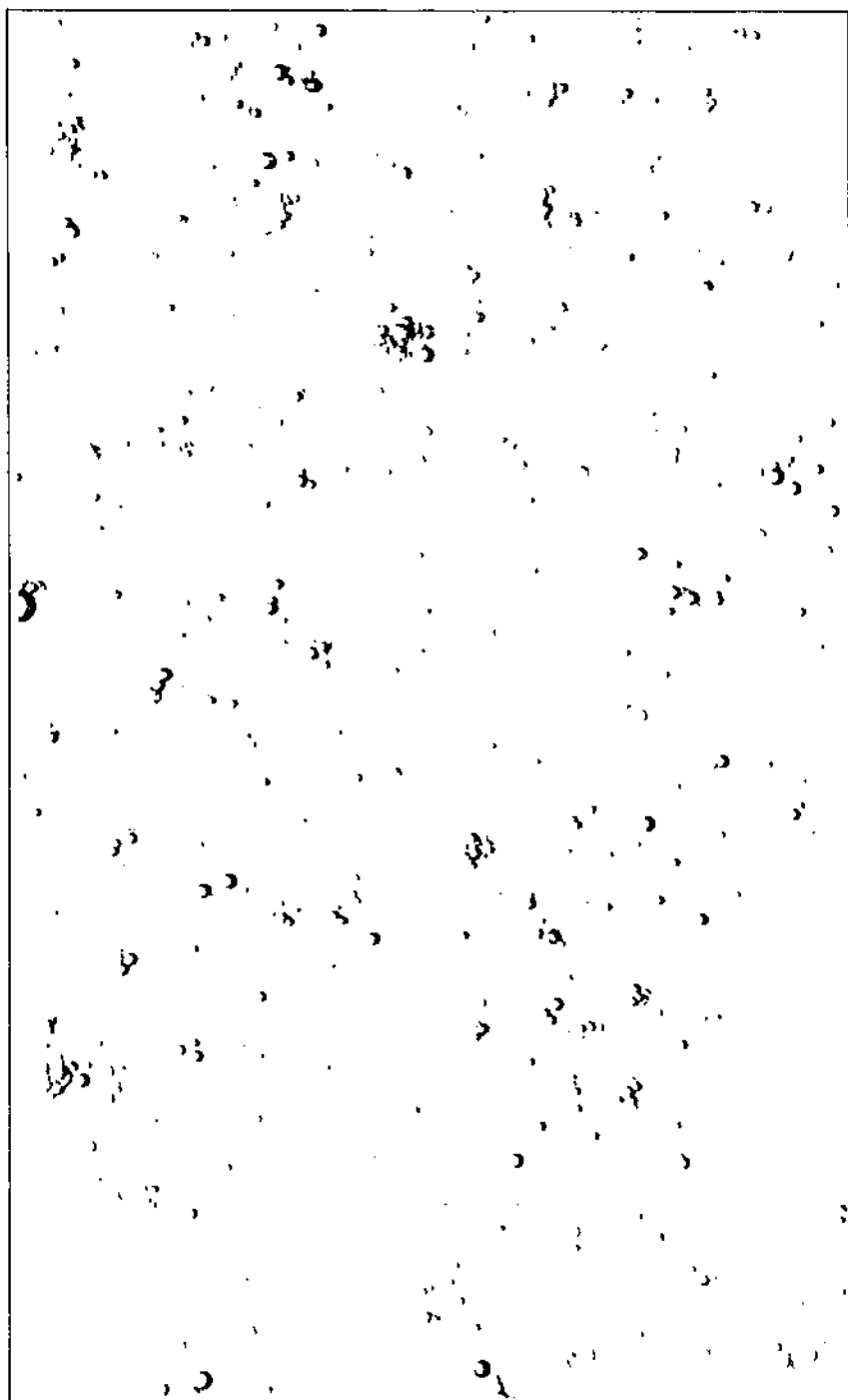

TWENTY PER CENT CREAM HOMOGENIZED AND REHOMOGENIZED AT 2,000 POUNDS PRESSURE PER SQUARE INCH AT 62° C. X 500

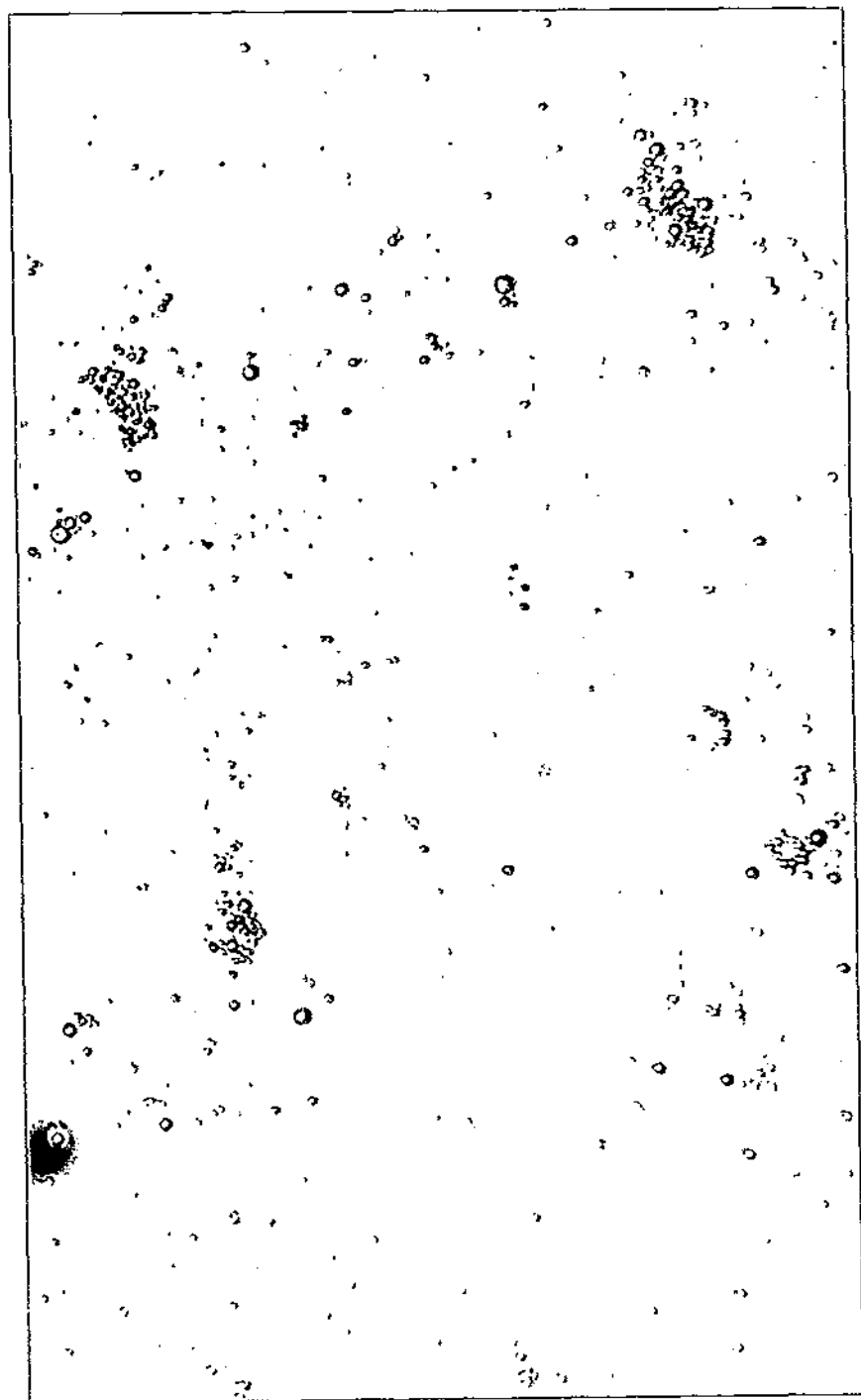

CREAM CONTAINING 20.5 PER CENT BUTTERFAT AND 2.95 PER CENT SOLIDS NOT FAT. HOMOGENIZED AT 3,000 POUNDS PRESSURE PER SQUARE INCH. $\times 500$

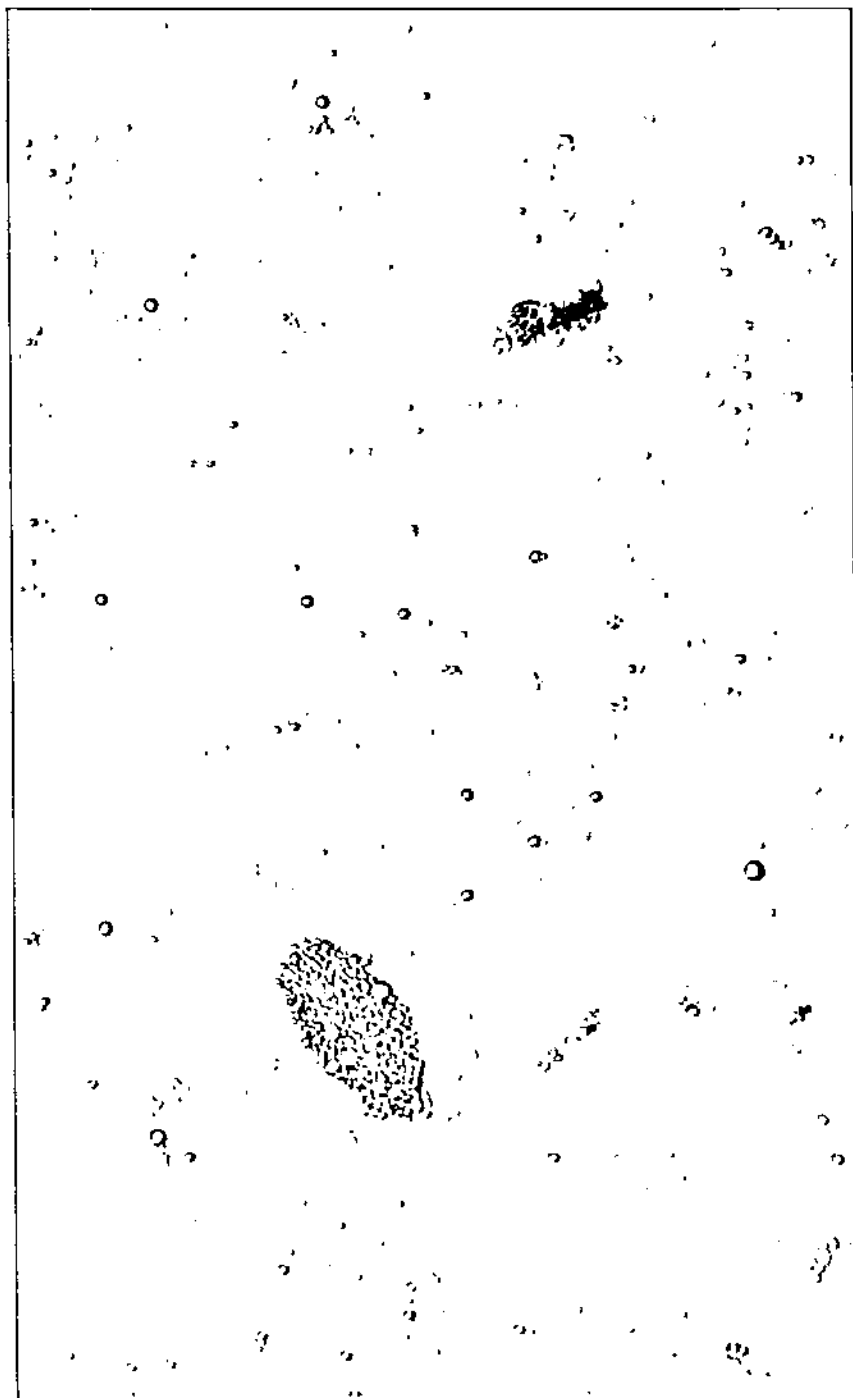

CREAM CONTAINING 20.5 PER CENT BUTTERFAT, AND 4.14 PER CENT SOLIDS NOT FAT, HOMOGENIZED AT 3,000 POUNDS PRESSURE PER SQUARE INCH. X 500

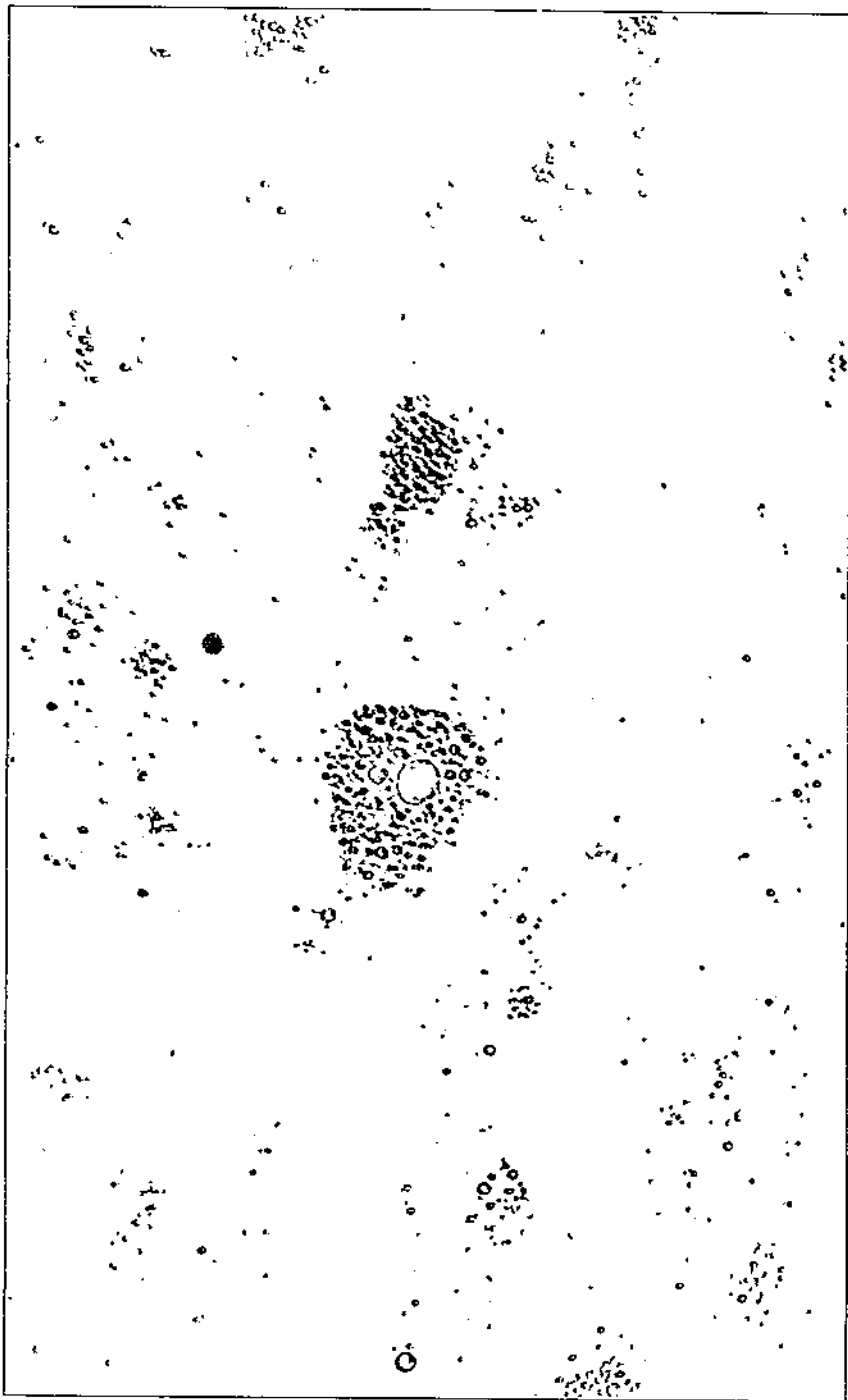

CREAM CONTAINING 20.5 PER CENT BUTTERFAT, AND 8.80 PER CENT SOLIDS NOT FAT. HOMOGENIZED AT 3,000 POUNDS PRESSURE PER SQUARE INCH. \times 500

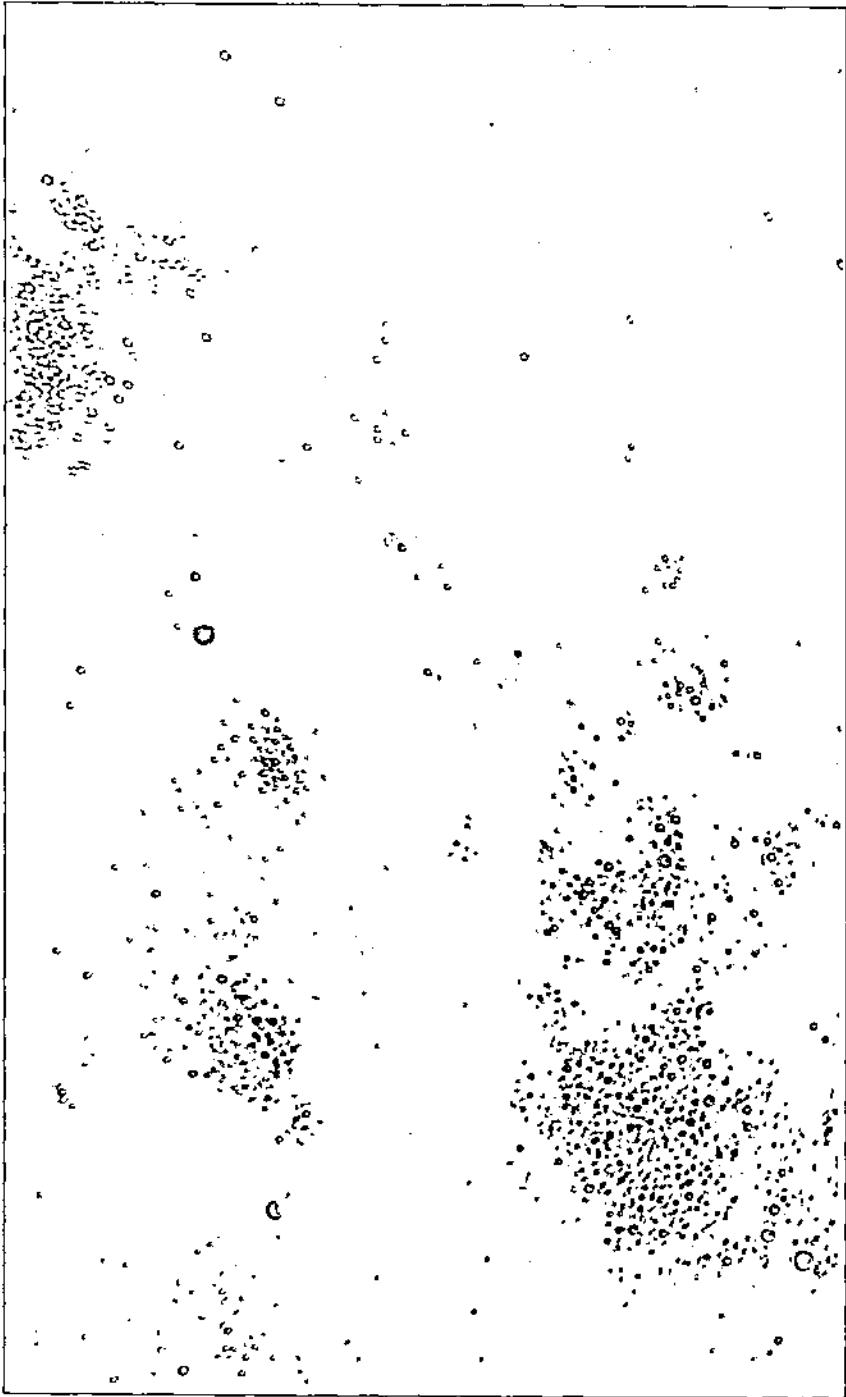

CREAM CONTAINING 20.5 PER CENT BUTTERFAT, AND 11.40 PER CENT SOLIDS NOT FAT. HOMOGENIZED AT 3,000 POUNDS PRESSURE PER SQUARE INCH. \times 500

lot fat the lower was the relative viscosity. As the percentage of solids not fat was increased the relative viscosity increased. The increase in relative viscosity was gradual until the percentage of solids not fat reached normal, but above the normal percentage of solids not fat the increase was more rapid. This was true especially when

TABLE 10.—Effect of solids not fat upon the viscosity of cream with a butterfat content of 20.5 per cent

Solids not fat (per cent)	Relative viscosity at 30° C. of—	
	Cream preheated to 80° C.	Cream preheated to 80° C., and homogenized at 3,000 pounds
2.95	1.25	1.44
4.14	1.30	1.50
6.29	1.39	1.62
8.80	1.58	2.20
11.40	1.84	2.71

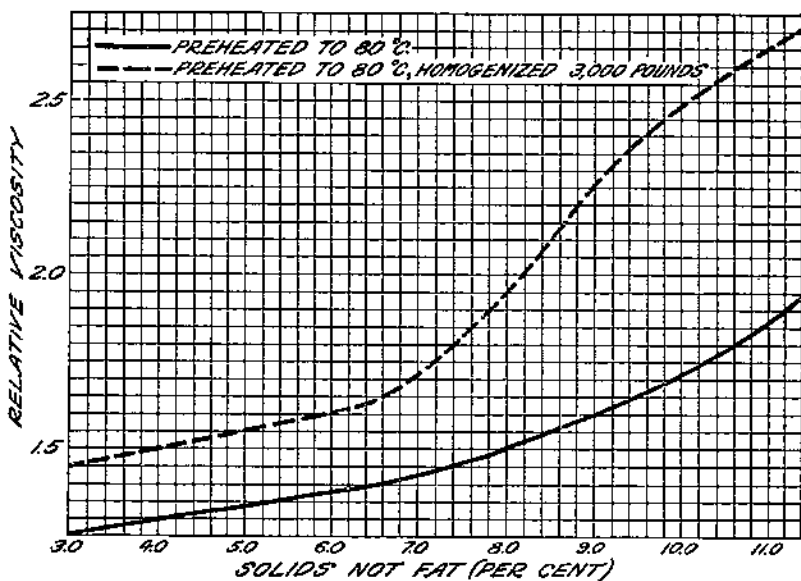

FIGURE 10.—Effect of solids not fat upon the viscosity of cream with a butterfat content of 20.5 per cent

the cream was homogenized. The relative viscosity of the homogenized cream was markedly greater when the percentage of solids not fat was above normal. (Table 10 and fig. 10.)

A microscopic study of the fat globules in cream with the same butterfat content, but with various percentages of solids not fat, showed a variation in the degree of clumping. This variation was noticeable in the homogenized cream particularly. (Pls. 18 to 21, inclusive.)

CONCLUSIONS

There are a number of factors which may affect the viscosity of cream, but those which affect the fat phase are probably the more important, because any factor which affects the clumping of fat globules affects the viscosity of cream.

The viscosity of cream increases as the butterfat content is increased. It also increases as the temperature is lowered.

The viscosity of cream is lowered by pasteurization. The temperature of pasteurization, however, has but little effect upon the viscosity. Pasteurized cream increases in viscosity with age, but not to so great an extent as does raw cream. The greatest increase in viscosity (in the case of either pasteurized or raw cream) takes place during the first 24 hours of aging, and at 48 hours the maximum is approached. When the cream is homogenized there is practically no increase in viscosity, and when cream is both pasteurized and homogenized there is no increase in viscosity with age.

The increase in viscosity with age is accompanied by an increase in the amount of clumping of the fat globules.

The viscosity of gravity-separated cream is higher than that of centrifugally separated cream.

Standardizing cream to a specific butterfat content has practically no effect on its viscosity.

The freezing of cream lowers its viscosity. The viscosity of cream which has been frozen is not restored with age.

Acidity, unless in excess of 0.3 per cent, has but a slight effect on the viscosity of cream.

Raw or pasteurized cream that has been cooled slowly has a higher viscosity than raw or pasteurized cream that has been cooled rapidly.

The lower the separating temperature, the higher the viscosity of cream.

When the milk is held in storage before it is separated the viscosity of the cream is affected by the length of time in storage and the temperature during storage. When storage was at 4° C. the viscosity was increased more than when storage was at 18°. Storing the milk for 12 hours resulted in higher viscosity than storing for only 3 hours.

Cream from milk pasteurized before being separated has a lower viscosity than when the cream is separated and then pasteurized, unless the pasteurized milk is cooled slowly before being separated.

Homogenization of cream increases its viscosity. The increase in viscosity is in direct relation to the homogenizing pressure.

The increase in viscosity due to homogenizing at a given pressure depends upon the temperature at which the cream is homogenized.

Rehomogenization of cream lowers its viscosity.

The viscosity of cream increases as the percentage of solids not fat increases. This is true especially with homogenized cream.

LITERATURE CITED

- (1) ACHARD, G., and STASSANO, H.
1925. QUELQUES CONSTANTES PHYSICO-CHEMIQUES DU LAIT CU ET DU LAIT PASTEURISE SELON DIFFERENTS PROCEDES. *Compt. Rend. Soc. Biol. [Paris]* 93: 708-710.
- (2) BABCOCK, S. M.
1897. THE CONSTITUTION OF MILK WITH ESPECIAL REFERENCE TO CHEESE PRODUCTION. *Wis. Agr. Expt. Sta. Bul.* 61, 21 p., illus.

- (3) BARCOCK, S. M., and RUSSELL, H. L.
1896. CONDITIONS AFFECTING THE CONSISTENCY OF MILK. Wis. Agr. Expt. Sta. Ann. Rpt. 13: 73-80, illus.
- (4) ——— and RUSSELL, H. L.
1896. ON THE RESTORATION OF THE CONSISTENCY OF PASTEURIZED MILK AND CREAM. Wis. Agr. Expt. Sta. Ann. Rpt. 13: 81-94, illus.
- (5) BATEMAN, G. M., and SHARP, P. F.
1923. A STUDY OF THE APPARENT VISCOSITY OF MILK AS INFLUENCED BY SOME PHYSICAL FACTORS. Jour. Agr. Research 36: 647-674, illus.
- (6) BURGWALD, L. H.
1923. SOME FACTORS WHICH INFLUENCE THE FEATHERING OF CREAM IN COFFEE. Jour. Agr. Research 26: 541-546.
- (7) CURTISS, C. F.
1927. DAIRY. Iowa Agr. Expt. Sta. Rpt. 1927: 31-33.
- (8) DAHLBERG, A. C., and HENING, J. C.
1925. VISCOSITY, SURFACE TENSION, AND WHIPPING PROPERTIES OF MILK AND CREAM. N. Y. State Agr. Expt. Sta. Tech. Bul. 113, 42 p., illus.
- (9) DAILLE, C. D., and MARTIN, W. H.
1925. THE EFFECT OF METHODS OF HOMOGENIZATION ON THE QUALITY OF ICE CREAM. Penn. Agr. Expt. Sta. Bul. 196 (Ann. Rpt. 33): 23-25.
- (10) DAM, W. VAN, and SIRKS, H. A.
1922. ONDERZOEKINGEN OVER DE OPROOMING VOLGENS HET FRIESCHE SYSTEEM. (UEBER DIE AUFRAHMUNG NACH DEN FRIESISCHEN SYSTEM.) Dept. Binnenland, Zaken en Landb. [Netherlands], Verslag. Landbouwk. Onderzoek. Rijkslandbouwproefsta. 26: [106]-191, illus. [In Dutch. Summary in German, p. 184-186.]
- (11) DOAN, F. J.
1927. "VISCOLIZED" MILK AND ITS DETECTION. Jour. Dairy Sci. 10: 501-512, illus.
- (12) ———
1929. SOME FACTORS AFFECTING THE FAT CLUMPING PRODUCED IN MILK AND CREAM MIXTURES WHEN HOMOGENIZED. Jour. Dairy Sci. 12: 211-230.
- (13) EVENSON, A. L., and FERRIS, L. W.
1924. THE VISCOSITY OF NATURAL AND REMADE MILK. Jour. Dairy Sci. 7: 177-188, illus.
- (14) MORTENSEN, M.
1918. FACTORS WHICH INFLUENCE THE YIELD AND CONSISTENCY OF ICE CREAM. Iowa Agr. Expt. Sta. Bul. 180, pp. [258]-283, illus.
- (15) FYNE, G. T., and LYONS, J.
1928. SOME FACTORS INFLUENCING VISCOSITY IN CREAM. World's Dairy Cong. Rpt. Proc. 1928: 184-188.
- (16) REID, W. H. E., and MOSELEY, W. K.
1926. THE EFFECT OF PROCESSING ON THE DISPERSION OF FAT IN AN ICE CREAM MIXTURE. Missouri Agr. Expt. Sta. Research Bul. 91, 25 p., illus.
- (17) SHERWOOD, F. F., and SMALLFIELD, H. L.
1926. FACTORS INFLUENCING THE VISCOSITY OF CREAM AND ICE CREAM. Jour. Dairy Sci. 9: 68-77.
- (18) STEINER, R.
1901. BEITRÄGE ZUR KENNNTNIS DES EINFLUSSES DER PASTEURISIERUNG AUF DIE BESCHAFFENHEIT DER MILCH UND AUF DEN BUTTERUNGSPROZESS. Milch Ztg. 30: 401-403.
- (19) WEBB, B. H., and HOLM, G. E.
1928. THE HEAT STABILITY AND FEATHERING OF SWEET CREAM, AS AFFECTED BY DIFFERENT HOMOGENIZATION PRESSURES AND DIFFERENT TEMPERATURES OF FOREWARMING. Jour. Dairy Sci. 11: 253-257, illus.
- (20) WHITAKER, R., SHERMAN, J. M., and SHARP, P. F.
1927. EFFECT OF TEMPERATURE ON THE VISCOSITY OF SKIMMILK. Jour. Dairy Sci. 10: [361]-371, illus.
- (21) WHITAKER, H. A., ARCHIBALD, R. W., SHERR L., and CLEMENT, C. E.
1925. EFFECT OF VARIOUS FACTORS ON THE CREAMING ABILITY OF MARKET MILK. U. S. Dept. Agr. Bul. 1344, 24 p., illus.
- (22) WOLL, F. W.
1896. THE EFFECT OF PASTEURIZATION AND STERILIZATION ON THE VISCOSITY AND FAT GLOBULES OF MILK AND CREAM. Wis. Agr. Expt. Sta. Ann. Rpt. (1895) 12: 164-173.

**ORGANIZATION OF THE UNITED STATES DEPARTMENT OF AGRICULTURE
WHEN THIS PUBLICATION WAS LAST PRINTED**

<i>Secretary of Agriculture</i>	ARTHUR M. HYDE.
<i>Assistant Secretary</i>	R. W. DUNLAP.
<i>Director of Scientific Work</i>	A. F. WOODS.
<i>Director of Regulatory Work</i>	W. G. CAMPBELL.
<i>Director of Extension Work</i>	C. W. WARBURTON.
<i>Director of Personnel and Business Administration</i>	W. W. STOCKBERGER.
<i>Director of Information</i>	M. S. EISENHOWER.
<i>Solicitor</i>	E. L. MARSHALL.
<i>Weather Bureau</i>	CHARLES F. MARVIN, <i>Chief</i> .
<i>Bureau of Animal Industry</i>	JOHN R. MOHLER, <i>Chief</i> .
<i>Bureau of Dairy Industry</i>	O. E. REED, <i>Chief</i> .
<i>Bureau of Plant Industry</i>	WILLIAM A. TAYLOR, <i>Chief</i> .
<i>Forest Service</i>	R. Y. STUART, <i>Chief</i> .
<i>Bureau of Chemistry and Soils</i>	H. G. KNIGHT, <i>Chief</i> .
<i>Bureau of Entomology</i>	C. L. MARLATT, <i>Chief</i> .
<i>Bureau of Biological Survey</i>	PAUL G. REDINGTON, <i>Chief</i> .
<i>Bureau of Public Roads</i>	THOMAS H. MACDONALD, <i>Chief</i> .
<i>Bureau of Agricultural Economics</i>	NILS A. OLSEN, <i>Chief</i> .
<i>Bureau of Home Economics</i>	LOUISE STANLEY, <i>Chief</i> .
<i>Plant Quarantine and Control Administration</i>	LEE A. STRONG, <i>Chief</i> .
<i>Grain Futures Administration</i>	J. W. T. DUVEL, <i>Chief</i> .
<i>Food and Drug Administration</i>	WALTER G. CAMPBELL, <i>Director of</i> <i>Regulatory Work, in Charge.</i>
<i>Office of Experiment Stations</i>, <i>Chief</i> .
<i>Office of Cooperative Extension Work</i>	C. B. SMITH, <i>Chief</i> .
<i>Library</i>	CLARABEL R. BARNETT, <i>Librarian</i> .

This bulletin is a contribution from

<i>Bureau of Dairy Industry</i>	O. E. REED, <i>Chief</i> .
<i>Division of Market-Milk Investigations</i>	ERNEST KELLY, <i>Senior Market-</i> <i>Milk Specialist, in Charge.</i>

END