



AgEcon SEARCH
RESEARCH IN AGRICULTURAL & APPLIED ECONOMICS

The World's Largest Open Access Agricultural & Applied Economics Digital Library

This document is discoverable and free to researchers across the globe due to the work of AgEcon Search.

Help ensure our sustainability.

Give to AgEcon Search

AgEcon Search

<http://ageconsearch.umn.edu>

aesearch@umn.edu

*Papers downloaded from **AgEcon Search** may be used for non-commercial purposes and personal study only. No other use, including posting to another Internet site, is permitted without permission from the copyright owner (not AgEcon Search), or as allowed under the provisions of Fair Use, U.S. Copyright Act, Title 17 U.S.C.*

No endorsement of AgEcon Search or its fundraising activities by the author(s) of the following work or their employer(s) is intended or implied.

TB 1566 (1977) USDA TECHNICAL BULLETINS UPDATA
CAST-IN-PLACE 2-FOOT CONCRETE TRAPEZOIDAL FLOW-MEASURING FLUMES
HUMPHREYS, A S BONDURANT, J A 1 OF 1

START

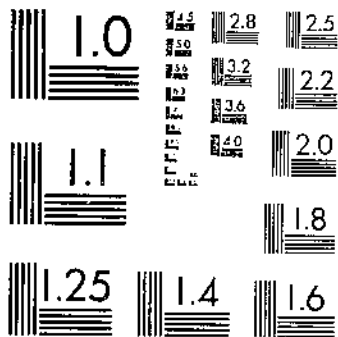

MICROCOPY RESOLUTION TEST CHART
NATIONAL BUREAU OF STANDARDS-1963-A

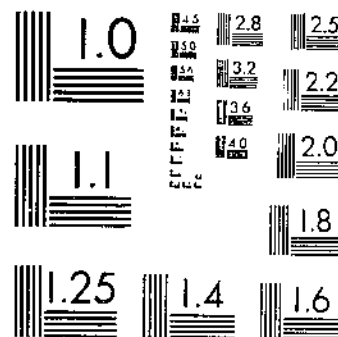

MICROCOPY RESOLUTION TEST CHART
NATIONAL BUREAU OF STANDARDS-1963-A

R
C 30.
U 53-1
#1566

57

CAST-IN-PLACE 2-FOOT CONCRETE TRAPEZOIDAL FLOW-MEASURING FLUMES

Technical Bulletin No. 1566

U. S. DEPOSITORY

FEB 2 1978

Los Angeles Public Library

Agricultural Research Service
UNITED STATES DEPARTMENT OF AGRICULTURE
In Cooperation With
Idaho Agricultural Experiment Station

16
A 1.36:1566

ABSTRACT

Humpherys, A. S., and Bondurant, J. A. 1977. Cast-in-place, 2-foot concrete trapezoidal flow-measuring flumes. U.S. Department of Agriculture Technical Bulletin No. 1566, 43 pp., 12 illus.

Procedures are presented for casting 50-ft³/sec trapezoidal water measurement flumes in 2-foot bottom width lined and unlined ditches. Drawings and construction details for the concrete forms used are also presented. Flumes installed in concrete-lined ditches require about 13 man-hours and cost about \$230. Flow can be determined for both free and submerged flow conditions from rating tables with depth measured in a stilling well or with a sloping gage on the flume sidewall.

KEYWORDS: Water measurement, Trapezoidal flumes, Water-measuring flumes, Irrigation, Irrigation systems, Water distribution systems.

ACKNOWLEDGMENT

A computer-predicted calibration developed by John Replogle, U.S. Water Conservation Laboratory, Phoenix, Ariz., was conveniently used to develop flow tables 1 and 2 since it closely paralleled the field calibration data in the low flow range and the original flume calibration in the middle and upper flow ranges.

The authors also acknowledge the contributions of Robert Stacey, engineering technician, for assistance in drafting and making field installations, and John Stevens, physical science technician, for developing the computer program used in constructing the flow tables. Both men are stationed at the Snake River Conservation Research Center.

CONTENTS

	<i>Page</i>
Introduction	1
Flume design and operation	1
Form design	4
Flume installation	7
Lined ditches	7
Unlined ditches	9
Cost	10
Summary	10
Appendix	11
Conversion to metric (SI) units	11
Flow tables	11

CAST-IN-PLACE 2-FOOT CONCRETE TRAPEZOIDAL FLOW-MEASURING FLUMES

By A. S. HUMPHERYS and J. A. BONBURANT, *ARS agricultural engineers*¹

INTRODUCTION

Water measurement is essential for complete water resource utilization and for the efficient operation and management of irrigation distribution systems. Water measurement has always been important, but regulations now require water measurement in many channels that do not have flow-measuring devices.

Trapezoidal flumes have several desirable features for measuring flow in open channels. They have low head losses and provide acceptable accuracies under relatively high degrees of submergence compared to weirs and other flumes. Their

shapes correspond to most irrigation ditches; they do not obstruct trash in the water, and they can easily be cast into existing concrete-lined ditches.

Procedures are available for installing and operating cast-in-place trapezoidal flume No. 1 (ASAE Standard designation 0.4 (1:1)-1.0 (1:1))² in standard slip-form-lined ditches with a 1-foot bottom width.³ Many of these small flumes have been installed in farm ditches and are providing good service. This report describes the construction and operation of a larger flume for installation in lined or unlined ditches with 2-foot bottom widths.

FLUME DESIGN AND OPERATION

Trapezoidal flume No. 2 (1.00 (1.25:1) — 2.0 (1.25:1)) has a 1.0-foot bottom throat width, 2.0-foot approach floor width, and 1.25:1 sidewall slopes.⁴ The complete flume dimensions are shown in figure 1. The range in flow measuring capacity is 0.33 to 52 cubic feet per second. The flume can be constructed with less depth for smaller design flows. The discharge for both free and submerged flow is presented in appendix table 1 for flow depths measured in the vertical direction and in appendix table 2 for flow depths measured along the sloping sidewalls.

The flumes are most accurate (± 5 percent) if operated under free-flow conditions. Free flow exists when submergence is less than 75 percent, where submergence is defined as the ratio of the down-

stream flume depth to the upstream flume depth, h_1/h_2 , in percent. When the channel slope is very small, the flumes must be raised above the ditch bottom in both lined and unlined ditches to provide free flow. The minimum channel slopes for different free flows in lined ditches are given in figure 2 at $\Delta Y = 0$. Most irrigation ditch slopes are less than these minimums so that most flumes must be raised to maintain free flow.

The required flume elevation, ΔY , is the difference between the normal downstream depth and $0.75 h_1$ (fig. 1). Flume elevations for various lined-ditch slopes and design flow rates are determined from figure 2. Normal depth in the ditch can be

¹ USDA/ARS, Snake River Conservation Research Center, Kimberly, Idaho 83341

² ASAE Standard: ASAE S359.1. Amer. Soc. Agr. Engin., St. Joseph, Mich.

³ BONBURANT, J. A., A. S. HUMPHERYS, and A. R. ROBINSON. CAST-IN-PLACE CONCRETE TRAPEZOIDAL MEASURING FLUMES. U.S. Dept. Agr., Agr. Res. Serv. ARS 41-155, 16 pp. 1969.

⁴ ROBINSON, A. R. TRAPEZOIDAL FLUMES FOR IRRIGATION CHANNELS. U.S. Dept. Agr., Agr. Res. Serv. ARS 41-140, 15 pp. 1968.

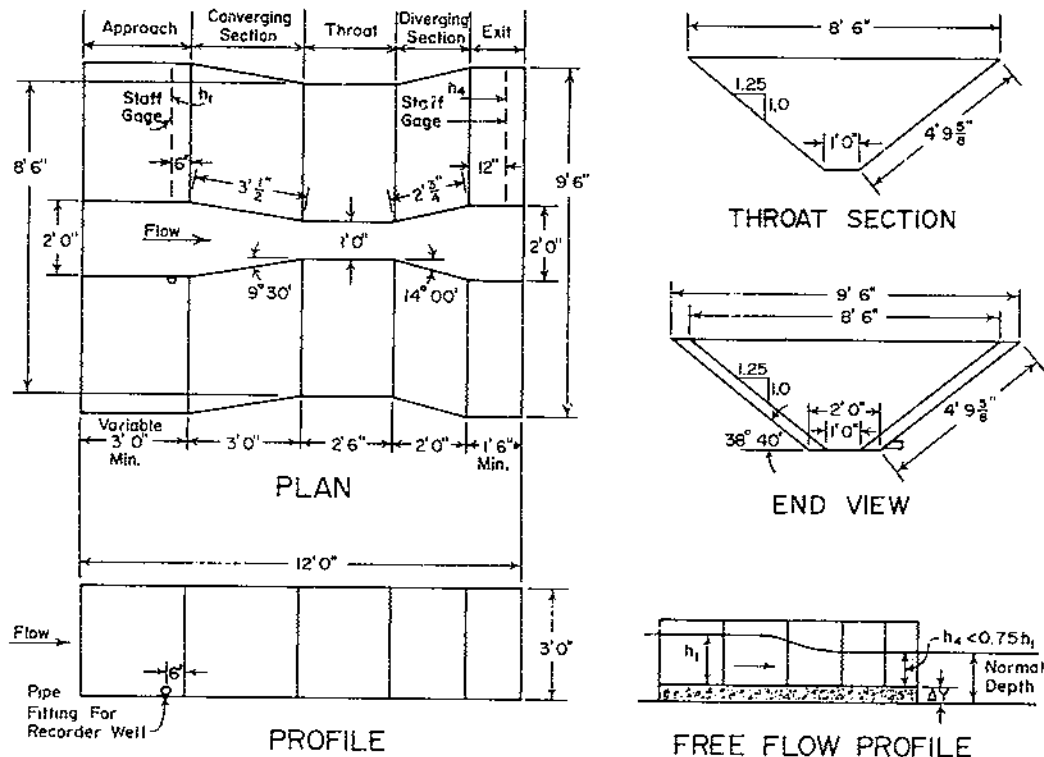

FIGURE 1.—Dimensions for trapezoidal flume No. 2.

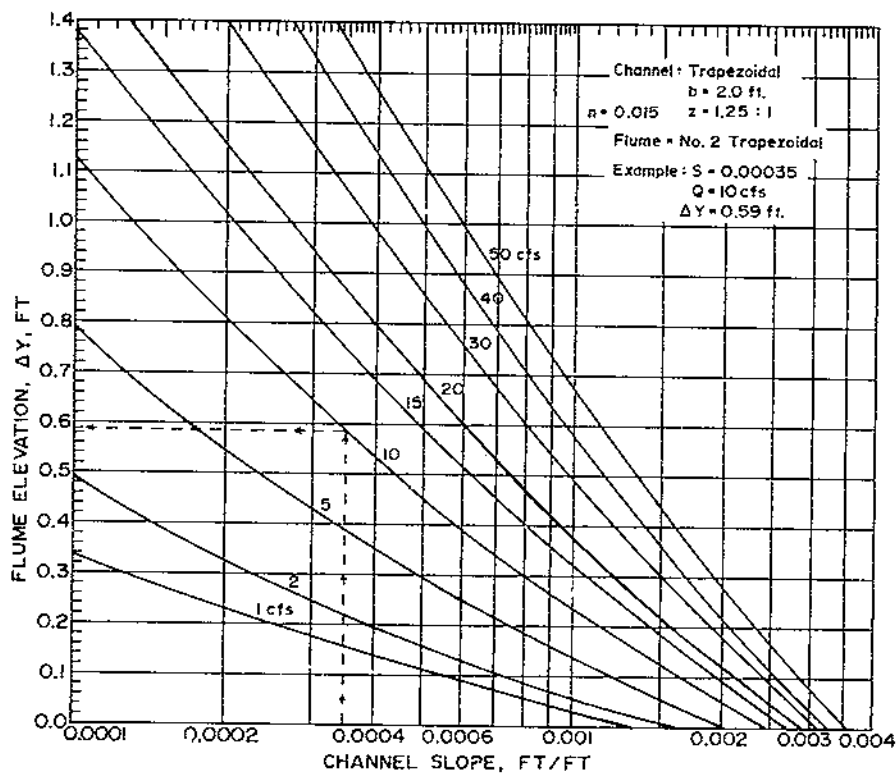

FIGURE 2.—Flume elevation, ΔY , for free flow at various lined-ditch slopes and flow rates.

determined by observing the existing design flow or from figure 3 for lined ditches. Flume elevation for the maximum design flow is more than adequate for all smaller flows. The flumes should be raised only the amount necessary to assure free flow to conserve elevation head, minimize downstream turbulence and erosion in unlined ditches, and eliminate the need for extra freeboard upstream from the flume. Minimum freeboard should not be less than 4 inches at the maximum design flow.

Flow can be determined with a single depth observation, h_1 , for free-flow conditions. When sufficient head is not available for free flow, good flow measurement (± 5 to 7 percent accuracy) can still be obtained with the flume operating up to 95 percent submergence. However, a second staff gage is required at the downstream, h_2 , location, as shown in figure 1. Flow depths at both the h_1 and h_2 locations are required to determine the discharge from the submerged-flow portion of the rating tables.

Steady state flow in most ditches that have mild or relatively flat slopes is described as normal flow. Critical flow occurs on somewhat steeper slopes, is unstable, and should be avoided. When the flow

velocity is greater than the critical velocity, the flow is supercritical. Supercritical flow occurs on steep slopes and, sometimes, immediately downstream from undershot-type turnout or diversion structures. The transition from supercritical to subcritical or normal flow occurs with a hydraulic jump. The flow upstream from a flume must be in the subcritical range.

Although supercritical velocity is seldom encountered, when it does occur, subcritical flow must be established above the flume. This can be accomplished by elevating and extending the approach section, installing blocks in the upstream channel, or creating a hydraulic jump by other means to convert the flow to subcritical. The conversion should occur far enough upstream so that turbulence and "bulking" from air entrainment are dissipated before the flow reaches the flume. When supercritical flows are encountered, additional freeboard upstream from the flume also may be required. Figure 3 may be used to determine whether normal flow in a lined ditch is at or near critical or supercritical.

The flow should approach the flume in a straight

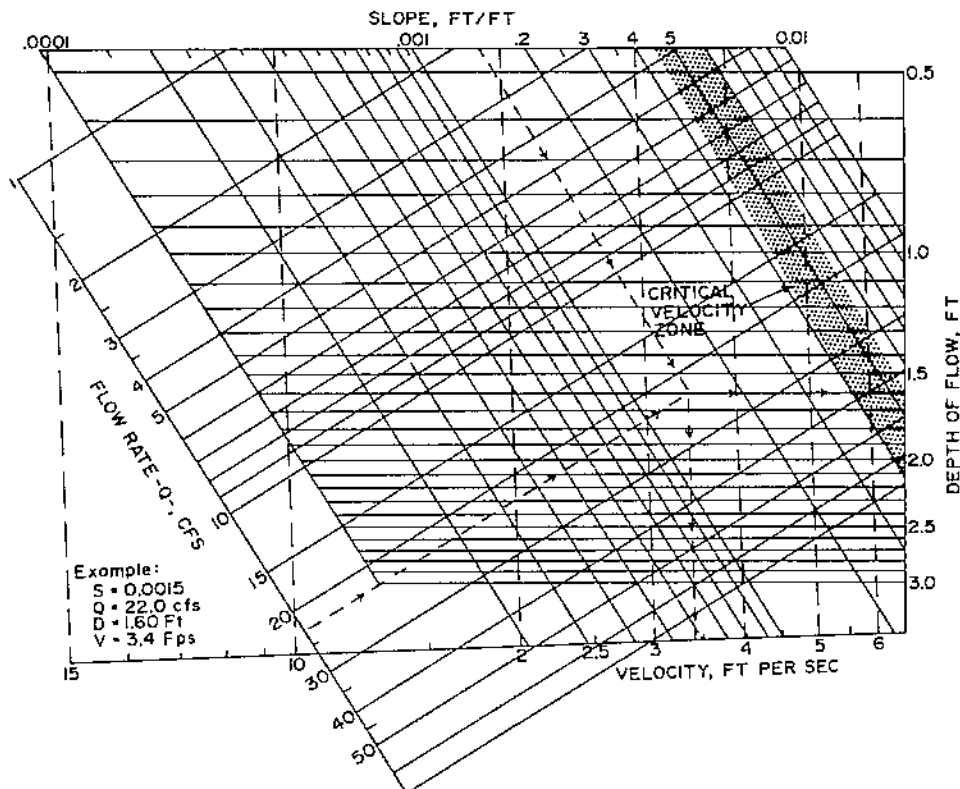
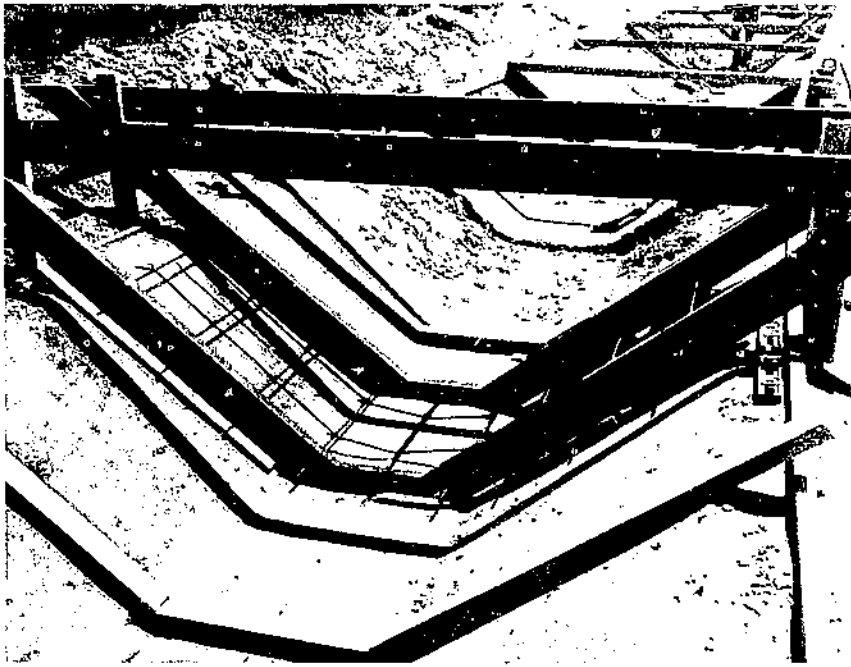
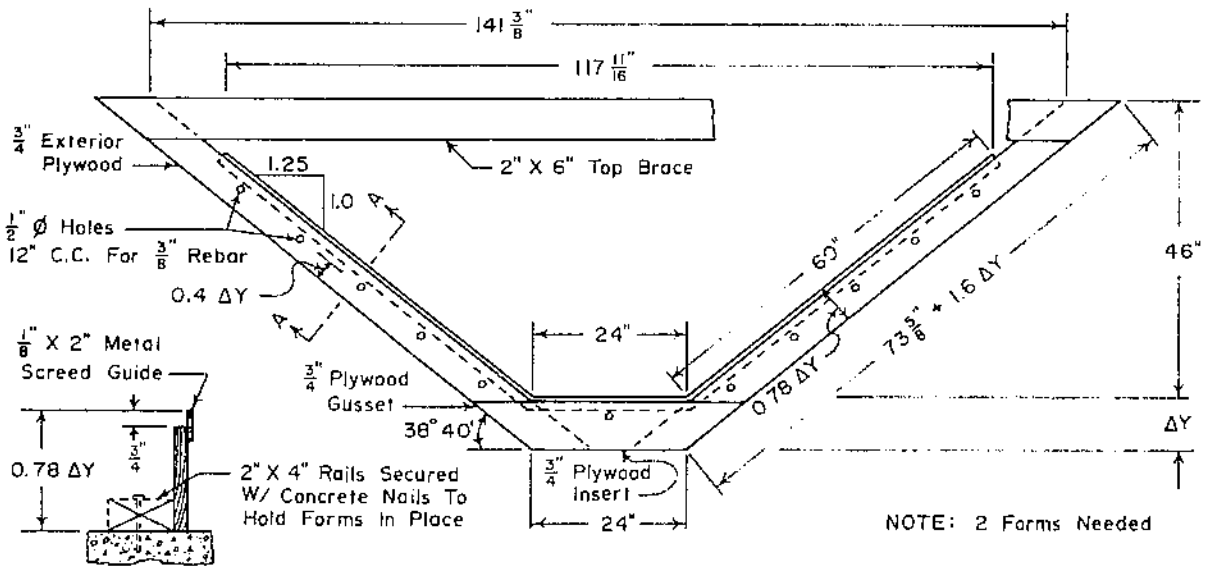

FIGURE 3.—Flow capacity of a concrete-lined ditch with 2.0-foot bottom, 1.25:1 side slope, and $n = 0.015$.



PN-5752

FIGURE 5.—Forms in place for casting the flume in a lined ditch. The flat wood strips are used to form the approach and end sections where the flume is to be elevated only a small distance above the ditch bottom. These should have narrow-edge screeding guides as shown in figs. 6 and 8 to facilitate screeding.



Side Section View A - A
(Rotated)

Elevation View

FIGURE 6.—Form for casting the flume end sections in a lined ditch for large values of ΔY .

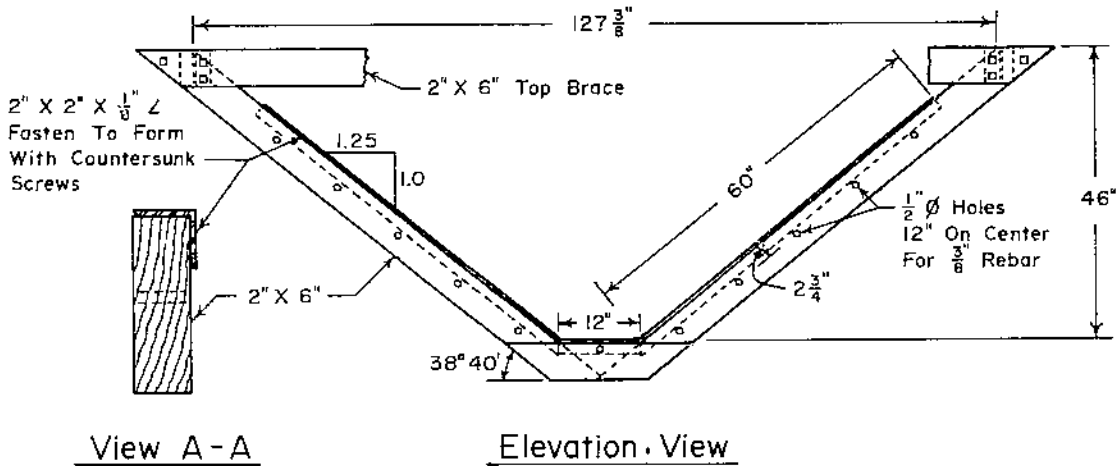
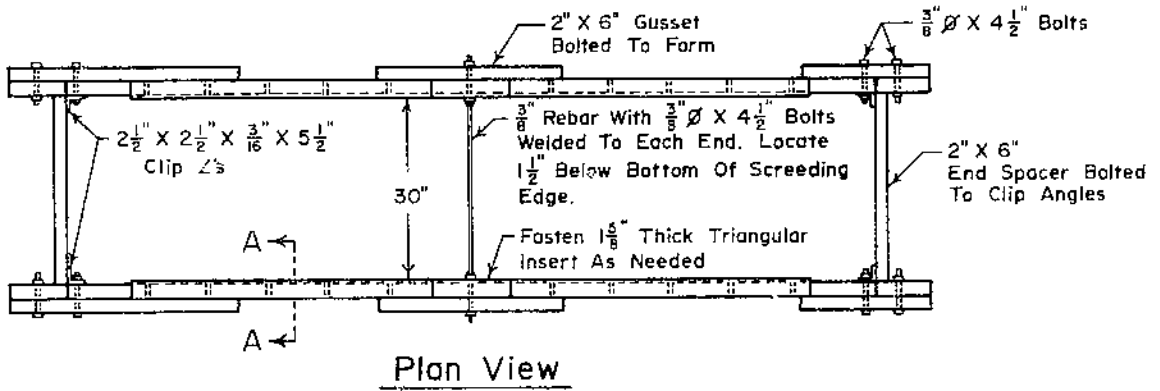

FIGURE 7.—Form for casting the throat section of a trapezoidal fume in an unlined ditch.

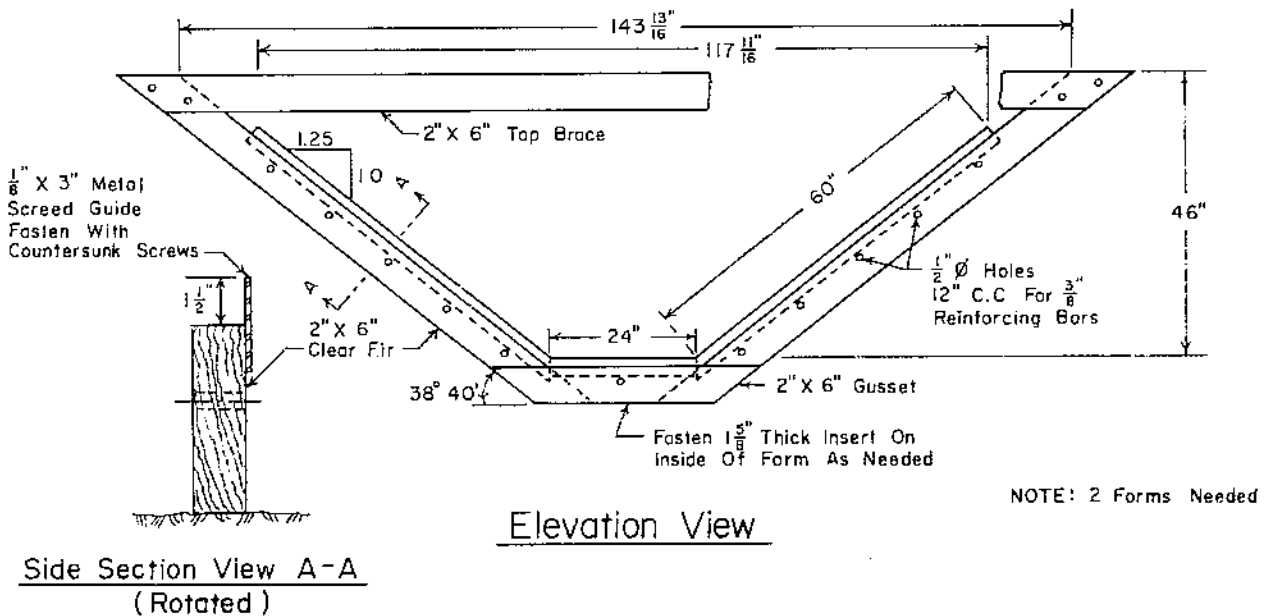

FIGURE 8.—Form for casting the end sections of a fume in an unlined ditch.

FLUME INSTALLATION

Lined Ditches

The ditch section chosen for the flume should be of sound concrete; cracked sections and poorly drained or other areas susceptible to frost damage should be avoided. The flume site should be thoroughly cleaned to obtain a good bond between the existing concrete and the cast flume. Moss and dirt accumulations, as well as loose cement particles that would interfere with bonding, can usually be removed with a wire brush. Cleaning is easier if a small amount of water is flowing in the ditch. The concrete surface in most lined ditches is rough enough so that scarifying is not needed to obtain a good bond.

Flumes with relatively large raised elevations, ΔY , can cause ponding in the ditch upstream from the flume. If turnouts or other means are not available for draining the ditch, it may be desirable to provide drainage to prevent ponding, particularly in the winter. This can be done by installing a 2-inch pipe on the original ditch bottom through the entire flume length. The pipe can be plugged or capped on the upstream end when not in use.

After the ditch lining has been cleaned, the form for the throat section is placed in the ditch. The form is centered using a taut string, as shown in figure 5, in relation to the ditch both upstream and downstream from the flume. The form is leveled in both directions and brought to the desired elevation using the ΔY extension plates and/or shims. Since the flume throat is the control section, it must be accurately leveled and aligned. The side slope should also be checked. However, if the form is constructed accurately, the side slope should be correct when the form is leveled.

After the form is leveled and aligned, it is held in place using wood stakes driven into the earth bank and/or wood strips fastened to the ditch lining with concrete nails. Reinforcing steel is placed as shown in figure 5 after the form is secured in place. Rebars 42 inches long provide 6-inch embedment lengths on each end to develop full bond. The rebar ends extend through holes in the form for bonding to the adjoining sections, which are cast later.

Type II cement is recommended, unless the soil sulfate concentration is 0.3 percent or greater, in which case type V should be used. The concrete should achieve a 28-day compressive strength of 3,000 pounds per square inch for average exposure

conditions of 20 to 80 freeze-thaw cycles per year, and have a cement content of $5\frac{3}{4}$ bags per cubic yard.⁶ For severe exposure conditions exceeding 80 freeze-thaw cycles, $6\frac{1}{2}$ bags of cement should be used. Air entrainment should be used for average and severe exposure conditions. A relatively stiff, 2- to 3-inch slump concrete mix is required. The amount of concrete needed for each section is given in table 1 for a full-depth flume. Concrete volumes required for each additional inch of flume elevation above $2\frac{9}{16}$ inches also are shown in the table. Volumes for approach sections longer than 3 ft need to be proportionately greater.

TABLE 1.—Volume of concrete for flumes

	Throat section	Converging and diverging sections	Approach and exit sections	Total
	Cubic feet	Cubic feet	Cubic feet	Cubic feet (Cubic yards)
Flume cast in lined ditch:				
Minimum flume elevation ¹	13.1	21.0	10.2	44.3 (1.7)
Each additional inch of flume elevation ²	2.1	4.3	3.9	10.3 (0.4)
Flume cast in unlined ditch ²	16.5	27.0	59.9	103.4 (2.2)

¹ $F = 2\frac{9}{16}$ inches.

² 3-ft approach section.

The ditch lining should be moistened before placing the concrete. The bottom is poured first, and the fresh concrete is screeded up the slope using the metal angles on the form as screed guides. After screeding, final touchup and smoothing can be done by hand-troweling. Excessive troweling should be avoided to prevent "slumping" of the concrete on the sides. Exact throat dimensions should be maintained. A curing compound should be applied immediately after finishing each section. Care is needed to prevent the curing agent from getting on

⁶ For additional concrete design information and specifications, see ASAC Standard ASAC S289, "Concrete slip-form canal and ditch linings," Amer. Soc. Agr. Engin., St. Joseph, Mich.

the edge of the casting where it could interfere with bonding of subsequent sections.

The forms should be left in place 12 to 24 hours to allow the concrete to develop enough strength so that it will not be damaged when the forms are removed or when installing the adjoining converging and diverging sections. The forms are separated by unbolting the spacers, and each side is removed individually by sliding it off the reinforcing rods.

After the throat forms are removed, the converging and diverging sections are poured. Each side of the poured throat section serves as a form for one of these sections. Steel reinforcing was used only in the throat section for the flume shown in figures 5 and 9 because of the small amount of flume elevation, ΔY . However, for thicker converging/diverging and approach/exit sections where ΔY exceeds 4 to 5 inches, it may be advisable to use additional reinforcing steel.

All forms are set level with the throat and are aligned with the throat and the ditch upstream and downstream with a taut string and are held in place with concrete nails. End forms consisting of wood strips, such as those shown in figure 5, can be accurately set to the exact cross section by measuring the top width at a given distance up the wall with a tape. The concrete is poured and finished the same as for the throat section. Screeding is more

difficult because the converging and diverging sections lie at an angle to the plane of the ditch lining. Short, screeding strokes are used with a short screed board working at an angle up the slope. Care must be taken not to scuff or damage the edges of the throat section while using them as screeding guides.

Forms used for casting the converging and diverging sections can be used for casting the approach and exit sections of the flume. They are set in place in the same manner. To minimize turbulence at the staff gage, the approach section needs to be longer as the flume elevation is increased. Recommended lengths are:

Flume elevation, ΔY Inches	Length of approach section Feet
0-3	3
4	4
5	5
6 or greater	6

A template or dummy gage, the same size as the staff gage, can be used to form a recess in the concrete for the staff gage(s). The template can be placed during the concrete finishing operation and left in place until the end forms are removed. The staff gages may be attached to the flume sidewall with concrete anchors or a waterproof cement. If they are cemented, wax-type curing agents must first be removed from the gage area.

The gage should be accurately "zeroed" and placed exactly on a 1.25 to 1.0 slope. Gage placement error can be minimized by installing the gage so that the sloping depth reading for a specific flow within the expected flow range is exactly the corresponding vertical distance above the flume bottom. This can be easily done by placing a metal template of fixed height in the throat section and transferring its exact elevation to the corresponding point on the sloping gage with a straight edge and level. When this procedure is used, depth measurements are most accurate in the expected flow range where the gage is zeroed. When the gage is zeroed from the bottom, the effect of placement error progressively increases with depth. Even very small deviations from the exact slope can result in errors of 5 percent or more in the low flow range. Conventional 2½-inch-wide enameled-iron gages can be used.

Because of the abrupt ΔY rise at the upstream end of the flume, a transition from the original lining to the raised end of the approach section should



PN-5753

FIGURE 9.—Completed throat and converging/diverging sections of a flume cast in a lined ditch. The end forms are in place for casting the approach and exit sections (see fig. 6 for screeding guides to use with these forms). Note the carpenter's level and template used as an aid in setting the forms to the correct side slope.

be provided. This can be free-formed or hand-troweled and helps to give a smoother water surface at the gage.

Precautions should be taken to prevent fresh concrete from freezing. The ditch lining on which the flume is cast should be above freezing temperature at the time of installation. The concrete should be protected from freezing for at least 3 days. Protective measures include heating the water and aggregate and covering with canvas, plastic, and/or loosely piled hay or straw.

Unlined Ditches

Flumes may be installed in unlined ditches or in an unlined section of a ditch that is to be lined, using procedures similar to those used for lined-ditch installations. The subgrade should be excavated to the elevation needed to raise the flume the desired amount above the ditch invert and also provide for a minimum floor thickness of $3\frac{5}{8}$ inches. The subgrade for the flume should be level. It is advisable to hand-trim the subgrade at the flume site to prevent overexcavation. The flume should be installed on undisturbed soil. If the soil has been disturbed, it should be settled by water and compacted to its original density.

The throat form is centered and alined in the ditch, brought to the correct elevation, and leveled in both directions. This is easier to do if the form is rigidly braced to maintain the correct dimensions before placing in the ditch. The end forms for the converging and diverging sections can be placed at the same time. They are set level with the throat section. The subgrade should be moist before pouring the concrete. Table I shows the amount of concrete needed for a flume cast on a level, raised subgrade with a $3\frac{5}{8}$ -inch floor thickness in the approach and exit sections and without cutoff walls.

After pouring the throat section, the concrete should cure 12 to 24 hours before removing the throat forms. Reinforcing steel for the converging and diverging sections is then placed as shown in figure 10, after which the concrete for these sections is poured. The completed flume section is shown in figure 11. Because of downstream conditions, this particular flume did not require elevating ($\Delta Y = 0$). Therefore, the adjoining ditch lining sections served as both the approach and exit sections for the flume.

The h_1 staff gage was placed at the required location in the approach ditch section. If the flume

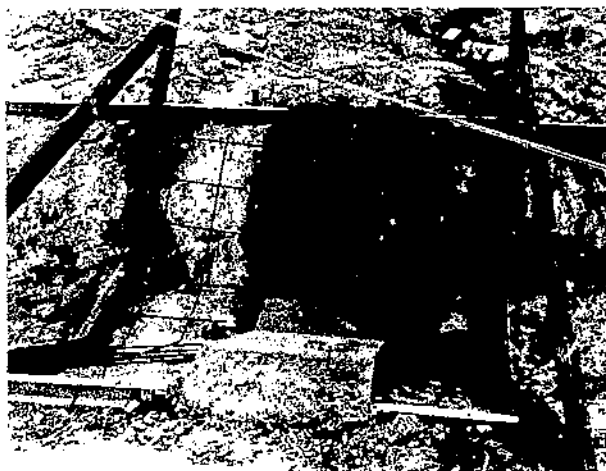

PN-5754

FIGURE 10.—Completed throat section of a flume in an unlined ditch prior to casting the converging and diverging sections.

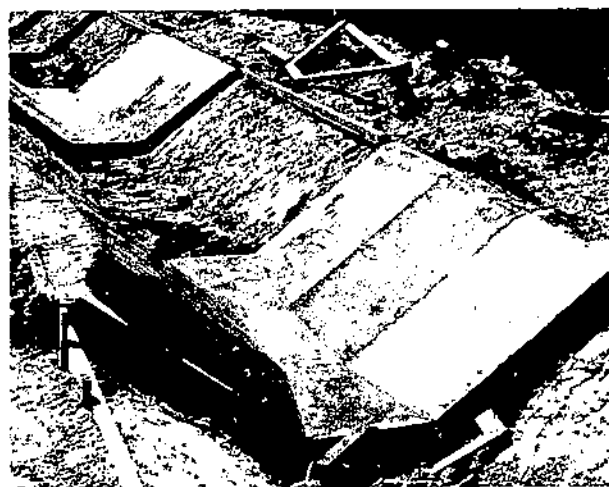

PN-5755

FIGURE 11.—Completed flume section in an unlined ditch. The adjoining ditch lining will serve as the approach and exit sections of the flume.

had been raised, or if the ditch were not to be lined, the approach and end sections would have been added to complete the installation. If the ditch is not lined at the time the flume is installed, cutoff walls are needed on each end of the flume. Reinforcing steel mesh can be used in the approach and exit sections when they are cast individually as part of the flume.

Stilling wells for water stage recorders can be

installed as shown in figure 12. The flume and recorder well are connected by a pipe finished flush with the inside of the flume. The pipe can be installed either at the same time that the approach and exit sections are poured, or later, and is located as shown in figure 1.

A floating raft upstream from the flume, as shown in figure 12, can be used to smooth a rough water surface and makes reading the gage easier.

PN-5766

FIGURE 12.—Completed trapezoidal flume with stilling well and recorder.



COST

Installation cost for a full-depth flume with a 6-foot approach section and the floor raised 6 inches in a lined ditch is approximately \$230, based on January 1977 prices. The same flume cast on a raised subgrade in an unlined section of ditch without cutoff walls costs approximately \$200. Costs are apportioned as follows:

	<i>Flume in lined ditch</i>	<i>Flume in unlined ditch</i>
Concrete ($3\frac{3}{4}$ and $2\frac{3}{4}$ yd ³ @ \$31/yd ³).....	\$116.25	\$ 85.25
Reinforcing steel ($\frac{3}{8}$ in \times 200 ft rebar and 60 ft ² mesh).....	26.00	26.00
Form prorated cost.....	14.00	16.50
Labor (13 hr @ \$5/hr).....	65.00	65.00
Miscellaneous (curing com- pound, staff gages).....	10.00	10.00
Total.....	<u>\$231.25</u>	<u>\$202.75</u>

The forms cost approximately \$260 for a lined ditch flume and about \$310 for an unlined ditch flume, if constructed separately. The lined-ditch throat form can be modified by adding an extension on the bottom so that it also can be used for both flumes. Because of the necessity to pour the flume in sections, the labor is extended over a 3-day period. Experienced workers should require less time than the $6\frac{1}{2}$ hours shown for a two-man crew.

SUMMARY

Concrete trapezoidal measuring flumes cast in existing slipform concrete-lined or unlined ditches provide economical and accurate water measurement. Procedures are presented for casting 50-ft³/s capacity flumes in 2-ft bottom lined and unlined ditches. Flumes installed in standard 2-ft, bottom-lined ditches require about 13 man-hours and cost

about \$230. Free-flow operating conditions permit flow measurement accuracies of ± 5 percent with well-constructed flumes. With limited head conditions and flumes operating partially submerged, good flow measurement accuracy can still be obtained. Recorders can be readily installed with the flumes for continuous flow records.

APPENDIX

Conversion To Metric (SI)¹ Units

Conversion to the metric system of measurements in the United States is expected to occur sometime within the next few years. The following conversion factors are included for the benefit of irrigators and others who will be using this publication:

To Convert—	Multiply—	By—
Inches to millimeters	inches	25.4
Inches to centimeters	inches	2.54
Feet to centimeters	feet	30.48
Feet to meters	feet	0.3048
Cubic feet to cubic meters	cubic feet	0.02832
Cubic yards to cubic meters	cubic yards	0.7646
Feet per second to meters per second	feet per second	0.3048
Cubic feet per second to liters per second	cubic feet per second	28.317
Cubic feet per second to cubic meters per second	cubic feet per second	0.02832
Acre to hectare	acre	0.4047
Acre to square meters	acre	4,047.
Acre-inch to cubic meter	acre-inch	102.79
Acre-foot to cubic meter	acre-foot	1,233.48

Flow Tables

The discharge for both free-flow and submerged-flow conditions with the flow depth measured in the vertical direction is contained in appendix table 1 for the flume's design flow range. The corresponding discharge with depth measured along the sloping sidewalls is contained in appendix table 2.

The free-flow discharge shown in appendix table 1 was computed from the equation

$$Q = C + C_1 h_v^{0.5} + C_2 h_v + C_3 h_v^{1.5} + C_4 h_v^2 + C_5 h_v^{2.5}$$

where

Q = free-flow discharge, in cubic feet per second

h_v = head measured vertically at the h_1 flume location, in feet

$$C = -0.07$$

$$C_1 = 0.6953$$

$$C_2 = -2.6269$$

$$C_3 = 7.8721$$

$$C_4 = -4.4588$$

$$C_5 = 5.0894$$

Submerged-flow discharge was determined from

$$Q_s = KQ$$

where

Q_s = submerged-flow discharge, in cubic feet per second

K = correction factor for different degrees of submergence (h_2/h_1) determined from

$$K = 5.1649 - 16.8116 (h_2/h_1) + 22.7857 (h_2/h_1)^2 - 10.4065 (h_2/h_1)^3$$

where

h_2 and h_1 are downstream and upstream flow depths, respectively.

Discharges shown in appendix table 2 were calculated from the same equations with

$$h_v = 0.625 h_s$$

where

h_s is the sloping gage depth

The free-flow discharge equation in metric units is

$$Q_m = -0.002 + 0.0357 h_m^{0.5} - 0.244 h_m + 1.3247 h_m^{1.5} - 1.359 h_m^2 + 2.8098 h_m^{2.5}$$

where

Q_m = free-flow discharge, in cubic meters per second

h_m = vertical depth at the h_1 flume location, in meters.

¹ SI = Système International d'Unités.

Table 1.--Free- and submerged-flow discharge (cubic feet per second) with water depths h_1 and h_4 measured vertically for trapezoidal flume No. 2 (2-ft bottom approach width, 1-ft bottom throat width, and 1.25:1⁴sidewall)

Free Flow		Submerged flow (CFS): H4(FT)													
H1 (FT)	(CFS)	0.14	0.15	0.16	0.17	0.18	0.19	0.20	0.21	0.22	0.23	0.24	0.25	0.26	0.27
0.20	0.33	0.33	0.32	0.32	0.31	0.30	0.28								
0.21	0.36		0.36	0.35	0.35	0.34	0.32								
0.22	0.39			0.38	0.38	0.37	0.36	0.35							
0.23	0.42				0.41	0.41	0.40	0.39	0.37						
0.24	0.45				0.45	0.44	0.44	0.43	0.42	0.40					
0.25	0.48					0.48	0.47	0.47	0.46	0.45	0.43				
0.26	0.52						0.51	0.51	0.50	0.49	0.48	0.45			
0.27	0.55						0.55	0.54	0.54	0.53	0.52	0.51	0.48		
0.28	0.59							0.58	0.58	0.57	0.57	0.55	0.54	0.51	
0.29	0.63								0.62	0.61	0.61	0.60	0.59	0.57	0.54

Free Flow		Submerged flow (CFS): H4(FT)															
H1 (FT)	(CFS)	0.21	0.22	0.23	0.24	0.25	0.26	0.27	0.28	0.29	0.30	0.31	0.32	0.33	0.34	0.35	0.37
0.30	0.66	0.66	0.65	0.65	0.64	0.63	0.62	0.60	0.57								
0.31	0.70		0.70	0.69	0.69	0.68	0.67	0.66	0.63	0.60							
0.32	0.74			0.74	0.73	0.73	0.72	0.71	0.69	0.67	0.64						
0.33	0.79				0.78	0.77	0.77	0.76	0.74	0.73	0.70	0.67					
0.34	0.83				0.82	0.82	0.81	0.81	0.80	0.78	0.76	0.74	0.70				
0.35	0.87					0.86	0.86	0.85	0.85	0.84	0.82	0.80	0.77	0.74			
0.36	0.92						0.91	0.90	0.90	0.89	0.88	0.86	0.84	0.81	0.78		
0.37	0.96						0.96	0.95	0.95	0.94	0.93	0.92	0.90	0.88	0.85	0.81	
0.38	1.01							1.00	1.00	0.99	0.98	0.98	0.96	0.94	0.92	0.89	
0.39	1.06								1.05	1.04	1.04	1.03	1.02	1.01	0.99	0.96	0.89

H1 (FT)	Free Flow (CFS)	Submerged flow (CFS): H4(FT)																		
		0.28	0.29	0.30	0.31	0.32	0.33	0.34	0.35	0.36	0.37	0.38	0.39	0.40	0.41	0.42	0.44	0.45	0.46	
0.40	1.11	1.10	1.10	1.09	1.09	1.08	1.07	1.05	1.03	1.00	0.97	0.93								
0.41	1.16		1.15	1.15	1.14	1.13	1.12	1.11	1.10	1.08	1.05	1.01								
0.42	1.21			1.20	1.20	1.19	1.18	1.17	1.16	1.14	1.12	1.09	1.05							
0.43	1.27				1.25	1.25	1.24	1.23	1.22	1.21	1.19	1.17	1.14	1.10						
0.44	1.32				1.31	1.30	1.30	1.29	1.28	1.27	1.26	1.24	1.21	1.18	1.14					
0.45	1.38					1.36	1.36	1.35	1.35	1.34	1.32	1.31	1.29	1.26	1.23	1.19				
0.46	1.43						1.42	1.41	1.41	1.40	1.39	1.38	1.36	1.34	1.31	1.28				
0.47	1.49							1.48	1.47	1.47	1.46	1.45	1.44	1.43	1.41	1.39	1.36	1.28		
0.48	1.55								1.54	1.53	1.53	1.52	1.51	1.50	1.48	1.47	1.44	1.37	1.33	
0.49	1.61									1.60	1.59	1.58	1.58	1.57	1.55	1.54	1.52	1.46	1.42	1.38

H1 (FT)	Free Flow (CFS)	Submerged flow (CFS): H4(FT)																			
		0.35	0.36	0.37	0.38	0.39	0.40	0.41	0.42	0.43	0.44	0.45	0.46	0.48	0.49	0.50	0.51	0.53	0.54	0.56	
0.50	1.67	1.66	1.66	1.65	1.64	1.63	1.62	1.61	1.60	1.57	1.55	1.51	1.47								
0.51	1.74		1.72	1.72	1.71	1.70	1.69	1.68	1.67	1.65	1.63	1.60	1.57	1.48							
0.52	1.80			1.78	1.78	1.77	1.76	1.76	1.74	1.73	1.71	1.69	1.66	1.58	1.53						
0.53	1.87				1.85	1.84	1.83	1.83	1.82	1.80	1.79	1.77	1.74	1.68	1.63	1.58					
0.54	1.93				1.92	1.91	1.90	1.90	1.89	1.88	1.87	1.85	1.83	1.77	1.73	1.69	1.63				
0.55	2.00					1.98	1.98	1.97	1.96	1.95	1.94	1.93	1.91	1.86	1.83	1.79	1.74				
0.56	2.07						2.05	2.04	2.04	2.03	2.02	2.01	1.99	1.95	1.92	1.89	1.85	1.74			
0.57	2.14							2.13	2.12	2.11	2.10	2.10	2.09	2.07	2.04	2.02	1.99	1.95	1.86	1.80	
0.58	2.22								2.20	2.19	2.18	2.17	2.16	2.15	2.12	2.10	2.08	2.05	1.97	1.92	
0.59	2.29									2.27	2.26	2.25	2.24	2.23	2.21	2.19	2.17	2.14	2.07	2.03	1.92

Table 1.--Free- and submerged-flow discharge (cubic feet per second) with water depths h_1 and h_2 measured vertically for trapezoidal flume No. 2 (2-ft bottom approach width, 1-ft bottom throat width, and 1.25:1⁴ sidewall)--Continued

H1 (FT)	Free Flow (CFS)	Submerged flow (CFS): H4(FT)																			
		0.42	0.43	0.44	0.45	0.46	0.47	0.49	0.50	0.51	0.52	0.53	0.55	0.56	0.58	0.59	0.60	0.62	0.64	0.65	
0.60	2.36	2.35	2.34	2.33	2.32	2.31	2.30	2.28	2.26	2.24	2.21	2.18	2.09	2.04							
0.61	2.44		2.42	2.41	2.40	2.40	2.39	2.36	2.35	2.33	2.31	2.28	2.20	2.15							
0.62	2.52			2.49	2.48	2.48	2.47	2.45	2.44	2.42	2.40	2.37	2.31	2.27	2.16						
0.63	2.59				2.57	2.56	2.55	2.53	2.52	2.51	2.49	2.47	2.41	2.38	2.28	2.22					
0.64	2.67				2.65	2.64	2.64	2.62	2.61	2.60	2.58	2.57	2.52	2.48	2.40	2.35	2.29				
0.65	2.76					2.73	2.72	2.71	2.70	2.69	2.67	2.66	2.62	2.59	2.52	2.47	2.42				
0.66	2.84						2.81	2.79	2.79	2.78	2.77	2.75	2.71	2.69	2.63	2.59	2.54	2.42			
0.67	2.92						2.90	2.88	2.87	2.87	2.86	2.84	2.81	2.79	2.74	2.70	2.66	2.55			
0.68	3.01							2.97	2.97	2.96	2.95	2.94	2.91	2.89	2.84	2.81	2.77	2.68	2.56		
0.69	3.09							3.06	3.06	3.05	3.04	3.03	3.01	2.99	2.95	2.92	2.89	2.80	2.69	2.63	
H1 (FT)	Free Flow (CFS)	Submerged flow (CFS): H4(FT)																			
		0.49	0.50	0.51	0.52	0.53	0.54	0.56	0.57	0.58	0.59	0.61	0.62	0.64	0.65	0.67	0.68	0.70	0.72	0.73	0.75
0.70	3.18	3.16	3.15	3.14	3.13	3.12	3.11	3.09	3.07	3.05	3.02	2.97	2.92	2.85	2.76						
0.71	3.27		3.24	3.24	3.23	3.22	3.21	3.19	3.17	3.15	3.12	3.09	3.04	2.97	2.89	2.79					
0.72	3.36			3.33	3.32	3.31	3.30	3.29	3.27	3.26	3.23	3.20	3.15	3.10	3.02	2.93	2.82				
0.73	3.46				3.42	3.41	3.40	3.39	3.37	3.36	3.34	3.31	3.27	3.22	3.15	3.07	2.97				
0.74	3.55				3.52	3.51	3.50	3.49	3.48	3.46	3.44	3.41	3.38	3.34	3.28	3.20	3.11	2.99			
0.75	3.64					3.61	3.60	3.59	3.58	3.56	3.55	3.52	3.49	3.45	3.40	3.34	3.25	3.14			
0.76	3.74					3.71	3.70	3.69	3.68	3.67	3.65	3.63	3.60	3.57	3.52	3.46	3.39	3.29	3.17		
0.77	3.84						3.80	3.79	3.78	3.77	3.76	3.74	3.71	3.68	3.64	3.59	3.52	3.43	3.33		
0.78	3.94							3.90	3.89	3.87	3.86	3.85	3.82	3.80	3.76	3.71	3.65	3.57	3.48	3.35	
0.79	4.04							4.00	3.99	3.98	3.97	3.95	3.93	3.91	3.88	3.84	3.78	3.71	3.62	3.51	3.38
H1 (FT)	Free Flow (CFS)	Submerged flow (CFS): H4(FT)																			
		0.56	0.57	0.58	0.59	0.61	0.62	0.63	0.65	0.66	0.67	0.69	0.70	0.72	0.74	0.75	0.77	0.79	0.81	0.83	0.85
0.80	4.14	4.11	4.10	4.09	4.08	4.06	4.05	4.03	4.01	3.98	3.94	3.89	3.82	3.74	3.64	3.51					
0.81	4.24		4.21	4.20	4.18	4.17	4.16	4.14	4.12	4.10	4.06	4.02	3.96	3.89	3.79	3.67					
0.82	4.35			4.31	4.30	4.28	4.27	4.26	4.24	4.21	4.18	4.14	4.09	4.03	3.94	3.83	3.70				
0.83	4.46			4.42	4.41	4.40	4.38	4.37	4.35	4.33	4.30	4.27	4.22	4.16	4.09	3.99	3.86				
0.84	4.56				4.52	4.51	4.50	4.48	4.47	4.45	4.42	4.39	4.35	4.30	4.23	4.14	4.03	3.89			

Free Flow		Submerged flow (CFS): H4(FT)--Continued																			
H1 (FT)	(CFS)	0.56	0.57	0.58	0.59	0.61	0.62	0.63	0.65	0.66	0.67	0.69	0.70	0.72	0.74	0.75	0.77	0.79	0.81	0.83	0.85
0.85	4.67					4.63	4.61	4.60	4.58	4.57	4.55	4.52	4.48	4.43	4.37	4.29	4.19	4.06			
0.86	4.78					4.74	4.73	4.72	4.70	4.69	4.67	4.64	4.61	4.56	4.51	4.43	4.34	4.22	4.08		
0.87	4.90						4.85	4.83	4.82	4.81	4.79	4.76	4.74	4.70	4.65	4.58	4.49	4.39	4.25		
0.88	5.01						4.97	4.95	4.94	4.93	4.91	4.89	4.86	4.83	4.78	4.72	4.64	4.55	4.42	4.27	
0.89	5.13							5.08	5.06	5.05	5.03	5.01	4.99	4.96	4.92	4.86	4.79	4.70	4.59	4.45	4.29

Free Flow		Submerged flow (CFS): H4(FT)																			
H1 (FT)	(CFS)	0.63	0.64	0.65	0.67	0.68	0.69	0.71	0.72	0.74	0.75	0.77	0.79	0.80	0.82	0.84	0.86	0.88	0.90	0.92	0.94
0.90	5.24	5.20	5.19	5.18	5.16	5.15	5.13	5.11	5.08	5.05	5.00	4.94	4.87	4.78	4.66	4.51					
0.91	5.36		5.32	5.30	5.29	5.27	5.26	5.24	5.21	5.18	5.14	5.09	5.02	4.94	4.83	4.69	4.52				
0.92	5.48			5.43	5.41	5.40	5.38	5.37	5.34	5.31	5.28	5.23	5.17	5.09	4.99	4.87	4.71				
0.93	5.60			5.56	5.54	5.53	5.51	5.49	5.47	5.45	5.42	5.37	5.32	5.25	5.16	5.04	4.90	4.72			
0.94	5.73				5.67	5.66	5.64	5.63	5.61	5.58	5.55	5.51	5.47	5.40	5.32	5.21	5.08	4.91			
0.95	5.85				5.80	5.79	5.77	5.76	5.74	5.72	5.69	5.66	5.61	5.55	5.48	5.38	5.26	5.10	4.92		
0.96	5.98					5.92	5.91	5.89	5.87	5.85	5.83	5.80	5.76	5.70	5.63	5.54	5.43	5.29	5.12		
0.97	6.11					6.06	6.04	6.02	6.01	5.99	5.97	5.94	5.90	5.85	5.79	5.71	5.60	5.47	5.31	5.12	
0.98	6.24						6.18	6.16	6.14	6.12	6.10	6.08	6.04	6.00	5.94	5.87	5.77	5.65	5.51	5.32	
0.99	6.37						6.32	6.30	6.28	6.26	6.24	6.22	6.19	6.15	6.10	6.03	5.94	5.83	5.69	5.52	5.32

Free Flow		Submerged flow (CFS): H4(FT)																			
H1 (FT)	(CFS)	0.70	0.71	0.73	0.74	0.75	0.77	0.79	0.80	0.82	0.83	0.85	0.87	0.89	0.91	0.93	0.95	0.97	0.99	1.01	1.04
1.00	6.50	6.45	6.43	6.42	6.40	6.38	6.36	6.34	6.30	6.26	6.21	6.15	6.06	5.95	5.82	5.65	5.44				
1.01	6.63		6.57	6.56	6.54	6.52	6.50	6.48	6.45	6.41	6.37	6.31	6.23	6.13	6.01	5.85	5.66				
1.02	6.77			6.70	6.68	6.67	6.65	6.63	6.60	6.57	6.52	6.47	6.40	6.31	6.19	6.05	5.87				
1.03	6.91			6.85	6.83	6.81	6.79	6.77	6.75	6.72	6.68	6.63	6.56	6.48	6.37	6.24	6.07	5.86			
1.04	7.05				6.97	6.96	6.94	6.92	6.90	6.87	6.83	6.79	6.73	6.65	6.55	6.43	6.27	6.08			
1.05	7.19				7.12	7.10	7.09	7.07	7.04	7.02	6.99	6.94	6.89	6.82	6.73	6.62	6.47	6.29	6.07		
1.06	7.33					7.25	7.24	7.22	7.19	7.17	7.14	7.10	7.05	6.99	6.91	6.80	6.67	6.50	6.29		
1.07	7.47					7.41	7.39	7.37	7.35	7.32	7.30	7.26	7.22	7.16	7.08	6.98	6.86	6.70	6.51	6.28	
1.08	7.62						7.54	7.52	7.50	7.48	7.45	7.42	7.38	7.32	7.25	7.16	7.05	6.90	6.73	6.51	
1.09	7.76						7.70	7.67	7.65	7.63	7.61	7.58	7.54	7.49	7.43	7.34	7.24	7.10	6.94	6.73	6.49

Table 1.—Free- and submerged-flow discharge (cubic feet per second) water depths h_1 and h_4 measured vertically for trapezoidal flume No. 2 (2-ft bottom approach width, 1-ft bottom throat width, and 1:25:1 sidewall)—Continued

H1 (FT)	Free Flow (CFS)	Submerged flow (CFS): H4(FT)																			
		0.77	0.78	0.80	0.81	0.83	0.85	0.86	0.88	0.90	0.91	0.93	0.95	0.97	0.99	1.02	1.04	1.06	1.08	1.11	1.13
1.10	7.91	7.85	7.83	7.81	7.79	7.77	7.75	7.72	7.68	7.64	7.58	7.50	7.41	7.28	7.13	6.94	6.70				
1.11	8.06		7.99	7.97	7.95	7.93	7.91	7.88	7.85	7.80	7.75	7.68	7.59	7.48	7.34	7.16	6.94				
1.12	8.22		8.15	8.13	8.11	8.09	8.07	8.04	8.01	7.97	7.92	7.86	7.78	7.67	7.54	7.37	7.17	6.91			
1.13	8.37			8.29	8.27	8.25	8.23	8.21	8.18	8.14	8.09	8.04	7.96	7.86	7.74	7.59	7.39	7.15			
1.14	8.52			8.46	8.44	8.42	8.39	8.37	8.34	8.31	8.27	8.21	8.14	8.05	7.94	7.79	7.61	7.39			
1.15	8.68				8.60	8.58	8.56	8.54	8.51	8.48	8.44	8.39	8.33	8.24	8.14	8.00	7.83	7.62	7.37		
1.16	8.84				8.77	8.75	8.73	8.70	8.68	8.65	8.61	8.57	8.51	8.43	8.33	8.21	8.05	7.85	7.61		
1.17	9.00					8.92	8.89	8.87	8.85	8.82	8.78	8.74	8.69	8.62	8.53	8.41	8.26	8.08	7.85	7.58	
1.18	9.16					9.09	9.06	9.04	9.02	8.99	8.96	8.92	8.87	8.80	8.72	8.61	8.48	8.30	8.09	7.84	
1.19	9.33						9.24	9.21	9.19	9.16	9.13	9.10	9.05	8.99	8.91	8.81	8.69	8.53	8.33	8.08	7.80
H1 (FT)	Free Flow (CFS)	Submerged flow (CFS): H4(FT)																			
		0.84	0.86	0.87	0.89	0.90	0.92	0.94	0.96	0.97	0.99	1.01	1.04	1.06	1.08	1.10	1.13	1.15	1.18	1.20	1.23
1.20	9.49	9.42	9.40	9.37	9.35	9.33	9.30	9.26	9.22	9.17	9.10	9.02	8.91	8.77	8.59	8.38	8.11				
1.21	9.66		9.57	9.55	9.53	9.50	9.47	9.44	9.40	9.36	9.29	9.21	9.11	8.98	8.82	8.62	8.37				
1.22	9.83		9.75	9.73	9.70	9.68	9.65	9.62	9.59	9.54	9.48	9.41	9.32	9.20	9.04	8.85	8.62	8.33			
1.23	10.0			9.9	9.9	9.9	9.8	9.8	9.8	9.7	9.7	9.6	9.5	9.4	9.3	9.1	8.9	8.6			
1.24	10.2			10.1	10.1	10.0	10.0	10.0	10.0	9.9	9.9	9.8	9.7	9.6	9.5	9.3	9.1	8.9	8.5		
1.25	10.3				10.2	10.2	10.2	10.2	10.1	10.1	10.1	10.0	9.9	9.8	9.7	9.5	9.4	9.1	8.8		
1.26	10.5				10.4	10.4	10.4	10.4	10.3	10.3	10.2	10.2	10.1	10.0	9.9	9.8	9.6	9.4	9.1		
1.27	10.7					10.6	10.6	10.5	10.5	10.5	10.4	10.4	10.3	10.2	10.1	10.0	9.8	9.6	9.3	9.0	
1.28	10.9					10.8	10.8	10.7	10.7	10.7	10.6	10.6	10.5	10.4	10.3	10.2	10.1	9.9	9.6	9.3	
1.29	11.1					11.0	10.9	10.9	10.9	10.9	10.8	10.8	10.7	10.7	10.6	10.4	10.3	10.1	9.9	9.6	9.2

H1 (FT)	Free Flow (CFS)	Submerged flow (CFS): H4(FT)																			
		0.91	0.93	0.94	0.96	0.98	1.00	1.01	1.03	1.05	1.07	1.10	1.12	1.14	1.16	1.19	1.21	1.24	1.27	1.29	1.32
1.30	11.2	11.2	11.1	11.1	11.1	11.0	11.0	11.0	10.9	10.9	10.8	10.7	10.6	10.4	10.2	10.0	9.7				
1.31	11.4		11.3	11.3	11.3	11.2	11.2	11.2	11.1	11.1	11.0	10.9	10.8	10.7	10.5	10.2	10.0	9.6			
1.32	11.6		11.5	11.5	11.5	11.4	11.4	11.4	11.3	11.3	11.2	11.1	11.0	10.9	10.7	10.5	10.2	9.9			
1.33	11.8			11.7	11.7	11.6	11.6	11.6	11.5	11.5	11.4	11.3	11.2	11.1	11.0	10.8	10.5	10.2			
1.34	12.0			11.9	11.9	11.8	11.8	11.8	11.7	11.7	11.6	11.6	11.5	11.3	11.2	11.0	10.8	10.5	10.1		
1.35	12.2				12.1	12.0	12.0	12.0	11.9	11.9	11.8	11.8	11.7	11.6	11.4	11.3	11.0	10.8	10.4		
1.36	12.4				12.3	12.2	12.2	12.2	12.1	12.1	12.1	12.0	11.9	11.8	11.7	11.5	11.3	11.0	10.7		
1.37	12.6				12.5	12.4	12.4	12.4	12.4	12.3	12.3	12.2	12.1	12.0	11.9	11.7	11.5	11.3	11.0	10.6	
1.38	12.8					12.7	12.6	12.6	12.6	12.5	12.5	12.4	12.4	12.3	12.1	12.0	11.8	11.6	11.3	10.9	
1.39	13.0					12.9	12.8	12.8	12.8	12.7	12.7	12.6	12.6	12.5	12.4	12.2	12.1	11.8	11.6	11.2	10.8

H1 (FT)	Free Flow (CFS)	Submerged flow (CFS): H4(FT)																			
		0.98	1.00	1.01	1.03	1.05	1.07	1.09	1.11	1.13	1.15	1.18	1.20	1.22	1.25	1.28	1.30	1.33	1.36	1.39	1.42
1.40	13.2	13.1	13.0	13.0	13.0	12.9	12.9	12.9	12.8	12.7	12.7	12.5	12.4	12.2	12.0	11.7	11.4				
1.41	13.4		13.3	13.2	13.2	13.2	13.1	13.1	13.0	13.0	12.9	12.8	12.7	12.5	12.3	12.0	11.7	11.3			
1.42	13.6		13.5	13.4	13.4	13.4	13.3	13.3	13.3	13.2	13.1	13.0	12.9	12.7	12.6	12.3	12.0	11.6			
1.43	13.8			13.7	13.6	13.6	13.6	13.5	13.5	13.4	13.3	13.3	13.1	13.0	12.8	12.6	12.3	11.9			
1.44	14.0			13.9	13.8	13.8	13.8	13.7	13.7	13.6	13.6	13.5	13.4	13.3	13.1	12.9	12.6	12.3	11.9		
1.45	14.2				14.1	14.0	14.0	14.0	13.9	13.9	13.8	13.7	13.6	13.5	13.3	13.1	12.9	12.6	12.2		
1.46	14.4				14.3	14.3	14.2	14.2	14.1	14.1	14.0	14.0	13.9	13.8	13.6	13.4	13.2	12.9	12.5	12.1	
1.47	14.6				14.5	14.5	14.4	14.4	14.4	14.3	14.3	14.2	14.1	14.0	13.9	13.7	13.4	13.2	12.8	12.4	
1.48	14.9					14.7	14.7	14.6	14.6	14.6	14.5	14.4	14.4	14.2	14.1	13.9	13.7	13.5	13.1	12.7	
1.49	15.1					14.9	14.9	14.9	14.8	14.8	14.7	14.7	14.6	14.5	14.4	14.2	14.0	13.7	13.4	13.1	12.6

CAST-IN-PLACE CONCRETE TRAPEZOIDAL FLUMES

Table 1.—Free- and submerged-flow discharge (cubic feet per second) water depths h_1 and h_2 measured vertically for trapezoidal flume No. 2 (2-ft bottom approach width, 1-ft bottom throat width, and 1:25¹/₄ sidewall)—Continued

H1 (FT)	Free Flow (CFS)	Submerged flow (CFS): H4(FT)																			
		1.05	1.07	1.09	1.11	1.13	1.15	1.17	1.19	1.21	1.23	1.26	1.28	1.31	1.34	1.36	1.39	1.42	1.45	1.48	1.51
1.50	15.3	15.2	15.1	15.1	15.1	15.0	15.0	14.9	14.9	14.8	14.7	14.6	14.4	14.2	14.0	13.7	13.3	12.9			
1.51	15.5		15.4	15.3	15.3	15.3	15.2	15.2	15.1	15.0	15.0	14.8	14.7	14.5	14.3	14.0	13.6	13.2			
1.52	15.7		15.6	15.6	15.5	15.5	15.5	15.4	15.4	15.3	15.2	15.1	15.0	14.8	14.6	14.3	14.0	13.5			
1.53	16.0			15.8	15.8	15.7	15.7	15.7	15.6	15.5	15.5	15.4	15.2	15.1	14.9	14.6	14.3	13.9	13.4		
1.54	16.2			16.1	16.0	16.0	15.9	15.9	15.8	15.8	15.7	15.6	15.5	15.3	15.1	14.9	14.6	14.2	13.8		
1.55	16.4			16.3	16.3	16.2	16.2	16.1	16.1	16.0	16.0	15.9	15.8	15.6	15.4	15.2	14.9	14.5	14.1		
1.56	16.7				16.5	16.5	16.4	16.4	16.3	16.3	16.2	16.1	16.0	15.9	15.7	15.5	15.2	14.9	14.4	14.0	
1.57	16.9				16.7	16.7	16.7	16.6	16.6	16.5	16.5	16.4	16.3	16.1	16.0	15.8	15.5	15.2	14.8	14.3	
1.58	17.1					17.0	16.9	16.9	16.8	16.8	16.7	16.6	16.5	16.4	16.3	16.1	15.8	15.5	15.1	14.7	
1.59	17.4					17.2	17.2	17.1	17.1	17.0	17.0	16.9	16.8	16.7	16.5	16.4	16.1	15.8	15.5	15.0	14.5

H1 (FT)	Free Flow (CFS)	Submerged flow (CFS): H4(FT)																			
		1.12	1.14	1.16	1.18	1.20	1.22	1.24	1.27	1.29	1.31	1.34	1.37	1.39	1.42	1.45	1.48	1.51	1.54	1.57	1.61
1.60	17.6	17.5	17.4	17.4	17.3	17.3	17.3	17.2	17.1	17.0	16.9	16.8	16.6	16.4	16.1	15.8	15.4	14.9			
1.61	17.8		17.7	17.6	17.6	17.6	17.5	17.5	17.4	17.3	17.2	17.1	16.9	16.7	16.4	16.1	15.7	15.2			
1.62	18.1		17.9	17.9	17.9	17.8	17.8	17.7	17.7	17.6	17.5	17.4	17.2	17.0	16.8	16.5	16.1	15.6			
1.63	18.3			18.2	18.1	18.1	18.0	18.0	17.9	17.8	17.7	17.6	17.5	17.3	17.1	16.8	16.4	16.0	15.4		
1.64	18.6			18.4	18.4	18.3	18.3	18.2	18.2	18.1	18.0	17.9	17.8	17.6	17.4	17.1	16.8	16.3	15.8		
1.65	18.8			18.7	18.6	18.6	18.5	18.5	18.4	18.4	18.3	18.2	18.1	17.9	17.7	17.4	17.1	16.7	16.2		
1.66	19.1				18.9	18.9	18.8	18.8	18.7	18.6	18.6	18.5	18.3	18.2	18.0	17.7	17.4	17.0	16.6	16.0	
1.67	19.3				19.2	19.1	19.1	19.0	19.0	18.9	18.8	18.7	18.6	18.5	18.3	18.1	17.8	17.4	16.9	16.4	
1.68	19.6				19.4	19.4	19.3	19.3	19.2	19.2	19.1	19.0	18.9	18.8	18.6	18.4	18.1	17.7	17.3	16.8	
1.69	19.8					19.7	19.6	19.6	19.5	19.5	19.4	19.3	19.2	19.1	18.9	18.7	18.4	18.1	17.7	17.2	16.6

H1 (FT)	Free Flow (CFS)	Submerged flow (CFS): H4(FT)																			
		1.19	1.21	1.23	1.25	1.27	1.30	1.32	1.34	1.37	1.39	1.42	1.45	1.48	1.51	1.54	1.57	1.60	1.63	1.67	1.70
1.70	20.1	20.0	19.9	19.9	19.8	19.8	19.7	19.7	19.6	19.5	19.4	19.2	19.0	18.8	18.5	18.1	17.6	17.1			
1.71	20.4		20.2	20.1	20.1	20.0	20.0	19.9	19.9	19.8	19.7	19.5	19.3	19.1	18.8	18.4	18.0	17.5			
1.72	20.6		20.5	20.4	20.4	20.3	20.3	20.2	20.1	20.1	19.9	19.8	19.6	19.4	19.1	18.8	18.4	17.9	17.2		
1.73	20.9			20.7	20.6	20.6	20.5	20.5	20.4	20.3	20.2	20.1	19.9	19.7	19.5	19.2	18.7	18.3	17.7		
1.74	21.2			21.0	20.9	20.9	20.8	20.8	20.7	20.6	20.5	20.4	20.3	20.1	19.8	19.5	19.1	18.6	18.1		
1.75	21.4			21.3	21.2	21.2	21.1	21.1	21.0	20.9	20.8	20.7	20.6	20.4	20.1	19.8	19.5	19.0	18.5		
1.76	21.7				21.5	21.4	21.4	21.3	21.3	21.2	21.1	21.0	20.9	20.7	20.5	20.2	19.8	19.4	18.9	18.2	
1.77	22.0				21.8	21.7	21.7	21.6	21.6	21.5	21.4	21.3	21.2	21.0	20.8	20.5	20.2	19.8	19.3	18.7	
1.78	22.3				22.1	22.0	22.0	21.9	21.9	21.8	21.7	21.6	21.5	21.3	21.1	20.9	20.5	20.2	19.7	19.1	
1.79	22.5					22.3	22.3	22.2	22.2	22.1	22.0	21.9	21.8	21.6	21.5	21.2	20.9	20.5	20.1	19.5	18.8

H1 (FT)	Free Flow (CFS)	Submerged flow (CFS): H4(FT)																			
		1.26	1.28	1.30	1.32	1.35	1.37	1.40	1.42	1.45	1.47	1.50	1.53	1.56	1.59	1.62	1.66	1.69	1.73	1.76	1.80
1.80	22.8	22.6	22.6	22.5	22.5	22.4	22.4	22.3	22.2	22.1	22.0	21.8	21.6	21.3	21.0	20.6	20.1	19.5			
1.81	23.1		22.9	22.8	22.8	22.7	22.7	22.6	22.5	22.4	22.3	22.1	21.9	21.7	21.4	21.0	20.5	19.9			
1.82	23.4		23.2	23.1	23.1	23.0	23.0	22.9	22.8	22.7	22.6	22.5	22.3	22.0	21.7	21.3	20.9	20.3	19.6		
1.83	23.7		23.5	23.4	23.4	23.3	23.3	23.2	23.1	23.0	22.9	22.8	22.6	22.4	22.1	21.7	21.3	20.7	20.1		
1.84	24.0			23.7	23.7	23.6	23.6	23.5	23.4	23.4	23.2	23.1	22.9	22.7	22.4	22.1	21.7	21.1	20.5		
1.85	24.3			24.0	24.0	23.9	23.9	23.8	23.7	23.7	23.6	23.4	23.3	23.1	22.8	22.5	22.0	21.5	20.9		
1.86	24.5			24.4	24.3	24.2	24.2	24.1	24.1	24.0	23.9	23.8	23.6	23.4	23.1	22.8	22.4	21.9	21.4	20.7	
1.87	24.8				24.6	24.6	24.5	24.4	24.4	24.3	24.2	24.1	23.9	23.7	23.5	23.2	22.8	22.4	21.8	21.1	
1.88	25.1				24.9	24.9	24.8	24.7	24.7	24.6	24.5	24.4	24.3	24.1	23.9	23.6	23.2	22.8	22.2	21.6	
1.89	25.4				25.2	25.2	25.1	25.1	25.0	24.9	24.8	24.7	24.6	24.4	24.2	23.9	23.6	23.2	22.6	22.0	21.3

Table 1.—Free- and submerged-flow discharge (cubic feet per second) water depths h_1 and h_2 measured vertically for trapezoidal flume No. 2 (2-ft bottom approach width, 1-ft bottom throat width, and 1:25¹/₁ sidewall)—Continued

H1 (FT)	Free Flow (CFS)	Submerged flow (CFS): H4(FT)																			
		1.33	1.35	1.37	1.40	1.42	1.45	1.47	1.50	1.53	1.55	1.58	1.61	1.65	1.68	1.71	1.75	1.78	1.82	1.85	1.89
1.90	25.7	25.5	25.5	25.4	25.4	25.3	25.2	25.2	25.1	25.0	24.8	24.6	24.4	24.1	23.7	23.3	22.7	22.0			
1.91	26.0		25.8	25.7	25.7	25.6	25.6	25.5	25.4	25.3	25.1	25.0	24.7	24.5	24.1	23.7	23.1	22.5			
1.92	26.4		26.1	26.1	26.0	25.9	25.9	25.8	25.7	25.6	25.5	25.3	25.1	24.8	24.5	24.1	23.6	22.9	22.2		
1.93	26.7		26.5	26.4	26.3	26.3	26.2	26.1	26.0	25.9	25.8	25.7	25.5	25.2	24.9	24.5	24.0	23.4	22.6		
1.94	27.0			26.7	26.7	26.6	26.5	26.5	26.4	26.3	26.2	26.0	25.8	25.6	25.3	24.9	24.4	23.8	23.1		
1.95	27.3			27.0	27.0	26.9	26.9	26.8	26.7	26.6	26.5	26.4	26.2	25.9	25.6	25.3	24.8	24.3	23.6		
1.96	27.6			27.4	27.3	27.3	27.2	27.1	27.0	27.0	26.8	26.7	26.5	26.3	26.0	25.7	25.2	24.7	24.0	23.3	
1.97	27.9				27.6	27.6	27.5	27.5	27.4	27.3	27.2	27.1	26.9	26.7	26.4	26.1	25.6	25.1	24.5	23.7	
1.98	28.2				28.0	27.9	27.9	27.8	27.7	27.6	27.5	27.4	27.2	27.0	26.8	26.5	26.1	25.6	24.9	24.2	
1.99	28.6				28.3	28.3	28.2	28.1	28.0	28.0	27.9	27.7	27.6	27.4	27.2	26.8	26.5	26.0	25.4	24.7	23.9

H1 (FT)	Free Flow (CFS)	Submerged flow (CFS): H4(FT)																			
		1.40	1.42	1.45	1.47	1.50	1.52	1.55	1.58	1.60	1.63	1.66	1.70	1.73	1.76	1.80	1.83	1.87	1.91	1.95	1.99
2.00	28.9	28.7	28.6	28.5	28.5	28.4	28.3	28.2	28.1	28.0	27.8	27.6	27.4	27.1	26.6	26.1	25.5	24.8			
2.01	29.2		28.9	28.9	28.8	28.7	28.7	28.6	28.5	28.4	28.2	28.0	27.8	27.4	27.1	26.6	26.0	25.3	24.4		
2.02	29.5		29.3	29.2	29.1	29.1	29.0	28.9	28.8	28.7	28.6	28.4	28.1	27.8	27.5	27.0	26.4	25.8	24.9		
2.03	29.9		29.6	29.6	29.5	29.4	29.4	29.3	29.2	29.1	28.9	28.7	28.5	28.2	27.9	27.4	26.9	26.2	25.4		
2.04	30.2			29.9	29.8	29.8	29.7	29.6	29.5	29.4	29.3	29.1	28.9	28.6	28.3	27.9	27.3	26.7	25.9		
2.05	30.5			30.3	30.2	30.1	30.1	30.0	29.9	29.8	29.7	29.5	29.3	29.0	28.7	28.3	27.8	27.2	26.4	25.5	
2.06	30.9			30.6	30.5	30.5	30.4	30.3	30.2	30.1	30.0	29.9	29.7	29.4	29.1	28.7	28.2	27.6	26.9	26.0	
2.07	31.2				30.9	30.8	30.8	30.7	30.6	30.5	30.4	30.2	30.0	29.8	29.5	29.1	28.7	28.1	27.4	26.6	
2.08	31.5				31.3	31.2	31.1	31.0	31.0	30.9	30.7	30.6	30.4	30.2	29.9	29.6	29.1	28.5	27.9	27.1	
2.09	31.9				31.6	31.5	31.5	31.4	31.3	31.2	31.1	31.0	30.8	30.6	30.3	30.0	29.5	29.0	28.4	27.6	26.7

H1 (FT)	Free Flow (CFS)	Submerged flow (CFS): H4(FT)																			
		1.47	1.49	1.52	1.54	1.57	1.60	1.62	1.65	1.68	1.71	1.75	1.78	1.81	1.85	1.89	1.92	1.96	2.00	2.04	2.08
2.10	32.2	32.0	31.9	31.8	31.8	31.7	31.6	31.5	31.4	31.3	31.1	30.9	30.6	30.2	29.8	29.2	28.6	27.8			
2.11	32.6		32.3	32.2	32.1	32.1	32.0	31.9	31.8	31.6	31.5	31.3	31.0	30.6	30.2	29.7	29.1	28.3	27.3		
2.12	32.9		32.7	32.6	32.5	32.4	32.4	32.3	32.2	32.0	31.9	31.7	31.4	31.1	30.7	30.2	29.5	28.8	27.9		
2.13	33.3		33.0	32.9	32.9	32.8	32.7	32.6	32.5	32.4	32.2	32.1	31.8	31.5	31.1	30.6	30.0	29.3	28.4		
2.14	33.6			33.3	33.2	33.2	33.1	33.0	32.9	32.8	32.6	32.4	32.2	31.9	31.5	31.1	30.5	29.8	28.9		
2.15	34.0			33.7	33.6	33.5	33.5	33.4	33.3	33.2	33.0	32.8	32.6	32.3	32.0	31.5	31.0	30.3	29.4	28.5	
2.16	34.4			34.1	34.0	33.9	33.8	33.8	33.7	33.6	33.4	33.2	33.0	32.7	32.4	32.0	31.4	30.8	30.0	29.0	
2.17	34.7				34.4	34.3	34.2	34.1	34.0	33.9	33.8	33.6	33.4	33.2	32.8	32.4	31.9	31.3	30.5	29.6	
2.18	35.1				34.8	34.7	34.6	34.5	34.4	34.3	34.2	34.0	33.8	33.6	33.3	32.9	32.4	31.7	31.0	30.1	
2.19	35.5				35.1	35.1	35.0	34.9	34.8	34.7	34.6	34.4	34.2	34.0	33.7	33.3	32.8	32.2	31.5	30.6	29.6

H1 (FT)	Free Flow (CFS)	Submerged flow (CFS): H4(FT)																			
		1.54	1.56	1.59	1.62	1.64	1.67	1.70	1.73	1.76	1.79	1.83	1.86	1.90	1.93	1.97	2.01	2.05	2.09	2.13	2.18
2.20	35.8	35.5	35.5	35.4	35.3	35.2	35.1	35.0	34.9	34.7	34.5	34.3	34.0	33.6	33.1	32.5	31.8	30.9			
2.21	36.2		35.9	35.8	35.7	35.6	35.5	35.4	35.3	35.2	35.0	34.7	34.4	34.1	33.6	33.0	32.3	31.5	30.4		
2.22	36.6		36.3	36.2	36.1	36.0	35.9	35.8	35.7	35.6	35.4	35.2	34.9	34.5	34.1	33.5	32.8	32.0	31.0		
2.23	36.9		36.6	36.6	36.5	36.4	36.3	36.2	36.1	36.0	35.8	35.6	35.3	35.0	34.5	34.0	33.3	32.5	31.6		
2.24	37.3			37.0	36.9	36.8	36.7	36.6	36.5	36.4	36.2	36.0	35.7	35.4	35.0	34.5	33.8	33.1	32.1		
2.25	37.7			37.4	37.3	37.2	37.1	37.0	36.9	36.8	36.6	36.4	36.2	35.9	35.5	35.0	34.3	33.6	32.7	31.6	
2.26	38.1			37.8	37.7	37.6	37.5	37.4	37.3	37.2	37.0	36.8	36.6	36.3	35.9	35.4	34.8	34.1	33.2	32.2	
2.27	38.5			38.2	38.1	38.0	37.9	37.8	37.7	37.6	37.4	37.3	37.0	36.7	36.4	35.9	35.3	34.6	33.8	32.8	
2.28	38.9				38.5	38.4	38.3	38.2	38.1	38.0	37.9	37.7	37.5	37.2	36.8	36.4	35.8	35.2	34.3	33.4	
2.29	39.3				38.9	38.8	38.7	38.6	38.5	38.4	38.3	38.1	37.9	37.6	37.3	36.9	36.3	35.7	34.9	33.9	32.8

CAST-IN-PLACE CONCRETE TRAPEZOIDAL FLUMES

Table 1.—Free- and submerged-flow discharge (cubic feet per second) water depths h_1 and h_2 measured vertically for trapezoidal flume No. 2 (2-ft bottom approach width, 1-ft bottom throat width, and 1:25¹:1 sidewall)—Continued

H1 (FT)	Free Flow (CFS)	Submerged flow (CFS): H4(FT)																			
		1.61	1.64	1.66	1.69	1.72	1.75	1.78	1.81	1.84	1.87	1.91	1.94	1.98	2.02	2.06	2.10	2.14	2.18	2.23	2.27
2.30	39.6	39.3	39.3	39.2	39.1	39.0	38.9	38.8	38.6	38.5	38.3	38.0	37.6	37.2	36.7	36.1	35.3*	34.3	33.2		
2.31	40.0		39.7	39.6	39.5	39.4	39.3	39.2	39.1	38.9	38.7	38.4	38.1	37.7	37.2	36.6	35.8	34.9	33.8		
2.32	40.4		40.1	40.0	39.9	39.8	39.7	39.6	39.5	39.3	39.1	38.9	38.6	38.2	37.7	37.1	36.3	35.4	34.4		
2.33	40.8		40.5	40.4	40.3	40.2	40.1	40.0	39.9	39.8	39.6	39.3	39.0	38.7	38.2	37.6	36.9	36.0	35.0		
2.34	41.2			40.8	40.7	40.7	40.6	40.5	40.3	40.2	40.0	39.8	39.5	39.1	38.7	38.1	37.4	36.6	35.5		
2.35	41.6			41.3	41.2	41.1	41.0	40.9	40.8	40.6	40.4	40.2	39.9	39.6	39.2	38.6	37.9	37.1	36.1	35.0	
2.36	42.0			41.7	41.6	41.5	41.4	41.3	41.2	41.1	40.9	40.7	40.4	40.1	39.7	39.1	38.5	37.7	36.7	35.6	
2.37	42.5			42.1	42.0	41.9	41.8	41.7	41.6	41.5	41.3	41.1	40.9	40.5	40.1	39.6	39.0	38.2	37.3	36.2	
2.38	42.9				42.5	42.4	42.3	42.2	42.1	41.9	41.8	41.6	41.3	41.0	40.6	40.1	39.5	38.8	37.9	36.8	
2.39	43.3				42.9	42.8	42.7	42.6	42.5	42.4	42.2	42.0	41.8	41.5	41.1	40.6	40.1	39.3	38.5	37.4	36.2

H1 (FT)	Free Flow (CFS)	Submerged flow (CFS): H4(FT)																			
		1.68	1.71	1.73	1.76	1.79	1.82	1.85	1.89	1.92	1.95	1.99	2.03	2.07	2.11	2.15	2.19	2.23	2.28	2.32	2.37
2.40	43.7	43.4	43.3	43.2	43.1	43.0	42.9	42.7	42.6	42.4	42.2	41.9	41.5	41.1	40.5	39.8	38.9	37.9	36.6		
2.41	44.1		43.7	43.6	43.5	43.4	43.3	43.2	43.0	42.9	42.6	42.4	42.0	41.6	41.0	40.3	39.5	38.5	37.3		
2.42	44.5		44.2	44.1	44.0	43.9	43.8	43.6	43.5	43.3	43.1	42.8	42.5	42.1	41.5	40.9	40.1	39.1	37.9		
2.43	45.0		44.6	44.5	44.4	44.3	44.2	44.1	43.9	43.8	43.6	43.3	43.0	42.6	42.1	41.4	40.6	39.7	38.5		
2.44	45.4			44.9	44.8	44.7	44.6	44.5	44.4	44.2	44.0	43.8	43.5	43.1	42.6	42.0	41.2	40.3	39.2		
2.45	45.8			45.4	45.3	45.2	45.1	45.0	44.8	44.7	44.5	44.3	44.0	43.6	43.1	42.5	41.8	40.9	39.8	38.5	
2.46	46.3			45.9	45.7	45.6	45.5	45.4	45.3	45.2	45.0	44.7	44.4	44.1	43.6	43.0	42.3	41.5	40.4	39.2	
2.47	46.7			46.3	46.2	46.1	46.0	45.9	45.8	45.6	45.4	45.2	44.9	44.6	44.1	43.6	42.9	42.0	41.0	39.8	
2.48	47.1				46.7	46.6	46.5	46.3	46.2	46.1	45.9	45.7	45.4	45.1	44.7	44.1	43.4	42.6	41.6	40.5	
2.49	47.6				47.1	47.0	46.9	46.8	46.7	46.5	46.4	46.2	45.9	45.6	45.2	44.6	44.0	43.2	42.2	41.1	39.8

H1 (FT)	Free Flow (CFS)	Submerged flow (CFS): H4(FT)																			
		1.75	1.78	1.81	1.84	1.87	1.90	1.93	1.96	2.00	2.03	2.07	2.11	2.15	2.19	2.23	2.28	2.32	2.37	2.41	2.46
2.50	48.0	47.6	47.5	47.4	47.3	47.2	47.1	47.0	46.8	46.6	46.3	46.0	45.6	45.1	44.5	43.8	42.8	41.7	40.4		
2.51	48.4		48.0	47.9	47.8	47.7	47.6	47.4	47.3	47.1	46.8	46.5	46.1	45.7	45.1	44.3	43.4	42.3	41.0		
2.52	48.9		48.5	48.4	48.3	48.1	48.0	47.9	47.7	47.6	47.3	47.0	46.7	46.2	45.6	44.9	44.0	43.0	41.7		
2.53	49.3		48.9	48.8	48.7	48.6	48.5	48.4	48.2	48.0	47.8	47.5	47.2	46.7	46.2	45.5	44.6	43.6	42.4		
2.54	49.8			49.3	49.2	49.1	49.0	48.8	48.7	48.5	48.3	48.0	47.7	47.3	46.7	46.1	45.2	44.2	43.0		
2.55	50.2			49.8	49.7	49.6	49.4	49.3	49.2	49.0	48.8	48.5	48.2	47.8	47.3	46.6	45.8	44.8	43.7	42.3	
2.56	50.7			50.3	50.1	50.0	49.9	49.8	49.7	49.5	49.3	49.0	48.7	48.3	47.8	47.2	46.4	45.5	44.3	43.0	
2.57	51.2			50.7	50.6	50.5	50.4	50.3	50.1	50.0	49.8	49.5	49.2	48.8	48.4	47.8	47.0	46.1	45.0	43.7	
2.58	51.6			51.2	51.1	51.0	50.9	50.8	50.6	50.5	50.3	50.0	49.7	49.4	48.9	48.3	47.6	46.7	45.6	44.3	
2.59	52.1				51.6	51.5	51.4	51.2	51.1	51.0	50.8	50.5	50.3	49.9	49.5	48.9	48.2	47.3	46.3	45.0	43.5

Table 2.—Free- and submerged-flow discharge (cubic feet per second) with water depths h_1 and h_4 measured on 1.25:1 sidewall with sloping gage for trapezoidal flume No. 2 (2-ft bottom approach width, 1-ft bottom throat width, and 1.25:1 sidewall)

H1 (FT)	Free Flow (CFS)	Submerged flow (CFS): H4(FT)																	
		0.21	0.22	0.23	0.24	0.25	0.26	0.27	0.28	0.29	0.30	0.31	0.32	0.33	0.34	0.35	0.37		
0.30	0.30	0.29	0.29	0.29	0.29	0.28	0.28	0.27	0.26										
0.31	0.31		0.31	0.31	0.31	0.30	0.30	0.29	0.28	0.27									
0.32	0.33			0.33	0.32	0.32	0.32	0.31	0.31	0.30	0.28								
0.33	0.35				0.34	0.34	0.34	0.34	0.33	0.32	0.31	0.30							
0.34	0.37				0.36	0.36	0.36	0.36	0.35	0.35	0.34	0.33	0.31						
0.35	0.38					0.38	0.38	0.38	0.37	0.37	0.36	0.35	0.34	0.33					
0.36	0.40						0.40	0.40	0.39	0.39	0.39	0.38	0.37	0.36	0.34				
0.37	0.42						0.42	0.42	0.41	0.41	0.41	0.40	0.40	0.39	0.37	0.36			
0.38	0.44							0.44	0.44	0.43	0.43	0.43	0.42	0.41	0.40	0.39			
0.39	0.46								0.46	0.46	0.45	0.45	0.45	0.44	0.43	0.42	0.39		

H1 (FT)	Free Flow (CFS)	Submerged flow (CFS): H4(FT)																	
		0.28	0.29	0.30	0.31	0.32	0.33	0.34	0.35	0.36	0.37	0.38	0.39	0.40	0.41	0.42	0.44	0.45	0.46
0.40	0.48	0.48	0.48	0.48	0.47	0.47	0.46	0.46	0.45	0.44	0.42	0.40							
0.41	0.50		0.50	0.50	0.50	0.49	0.49	0.48	0.48	0.47	0.45	0.44							
0.42	0.53			0.52	0.52	0.52	0.51	0.51	0.50	0.50	0.49	0.47	0.46						
0.43	0.55				0.54	0.54	0.54	0.53	0.53	0.52	0.51	0.50	0.49	0.47					
0.44	0.57				0.57	0.56	0.56	0.56	0.55	0.55	0.54	0.53	0.52	0.51	0.49				
0.45	0.59					0.59	0.58	0.58	0.58	0.58	0.57	0.56	0.55	0.54	0.53	0.51			
0.46	0.62						0.61	0.61	0.60	0.60	0.60	0.59	0.58	0.57	0.56	0.55			
0.47	0.64						0.63	0.63	0.63	0.63	0.62	0.62	0.61	0.61	0.60	0.58	0.55		
0.48	0.66							0.66	0.66	0.65	0.65	0.65	0.64	0.63	0.63	0.62	0.59	0.57	
0.49	0.69								0.68	0.68	0.68	0.67	0.67	0.66	0.66	0.65	0.62	0.61	0.59

H1 (FT)	Free Flow (CFS)	Submerged flow (CFS): H4(FT)																		
		0.35	0.36	0.37	0.38	0.39	0.40	0.41	0.42	0.43	0.44	0.45	0.46	0.48	0.49	0.50	0.51	0.53	0.54	0.56
0.50	0.71	0.71	0.71	0.70	0.70	0.70	0.69	0.69	0.68	0.67	0.66	0.65	0.63							
0.51	0.74		0.73	0.73	0.73	0.72	0.72	0.72	0.71	0.70	0.69	0.68	0.67	0.63						
0.52	0.76			0.76	0.75	0.75	0.75	0.74	0.74	0.73	0.73	0.72	0.70	0.67	0.65					
0.53	0.79				0.78	0.78	0.78	0.77	0.77	0.76	0.76	0.75	0.74	0.71	0.69	0.67				
0.54	0.82				0.81	0.81	0.81	0.80	0.80	0.79	0.79	0.78	0.77	0.75	0.73	0.71	0.69			
0.55	0.84					0.84	0.83	0.83	0.83	0.82	0.82	0.81	0.81	0.79	0.77	0.76	0.74			
0.56	0.87						0.86	0.86	0.86	0.85	0.85	0.85	0.84	0.82	0.81	0.80	0.78	0.73		
0.57	0.90						0.89	0.89	0.89	0.88	0.88	0.88	0.87	0.86	0.85	0.83	0.82	0.78	0.76	
0.58	0.93							0.92	0.92	0.91	0.91	0.91	0.90	0.89	0.88	0.87	0.86	0.83	0.80	
0.59	0.96								0.95	0.95	0.94	0.94	0.94	0.93	0.92	0.91	0.90	0.87	0.85	0.80

H1 (FT)	Free Flow (CFS)	Submerged flow (CFS): H4(FT)																		
		0.42	0.43	0.44	0.45	0.46	0.47	0.49	0.50	0.51	0.52	0.53	0.55	0.56	0.58	0.59	0.60	0.62	0.64	0.65
0.60	0.99	0.98	0.98	0.97	0.97	0.97	0.96	0.95	0.94	0.94	0.92	0.91	0.87	0.85						
0.61	1.02		1.01	1.01	1.00	1.00	1.00	0.99	0.98	0.97	0.96	0.95	0.92	0.90						
0.62	1.05			1.04	1.03	1.03	1.03	1.02	1.01	1.01	1.00	0.99	0.96	0.94	0.90					
0.63	1.08				1.07	1.06	1.06	1.05	1.05	1.04	1.04	1.03	1.00	0.99	0.95	0.92				
0.64	1.11				1.10	1.10	1.09	1.09	1.08	1.08	1.07	1.06	1.04	1.03	1.00	0.97	0.95			
0.65	1.14					1.13	1.13	1.12	1.12	1.11	1.11	1.10	1.08	1.07	1.04	1.02	1.00			
0.66	1.17						1.16	1.16	1.15	1.15	1.14	1.14	1.12	1.11	1.09	1.07	1.05	1.00		
0.67	1.21						1.20	1.19	1.19	1.18	1.18	1.17	1.16	1.15	1.13	1.11	1.10	1.05		
0.68	1.24							1.23	1.22	1.22	1.21	1.21	1.20	1.19	1.17	1.16	1.14	1.10	1.05	
0.69	1.27							1.26	1.26	1.25	1.25	1.25	1.24	1.23	1.21	1.20	1.19	1.15	1.11	1.08

Table 2.—Free- and submerged-flow discharge (cubic feet per second) with water depths h_1 and h_2 measured on 1.25:1 sidewall with sloping gage for trapezoidal flume No. 2 (2-ft bottom approach width, 1-ft bottom throat width, and 1.25:1 sidewall)—Continued

H1 (FT)	Free Flow (CFS)	Submerged flow (CFS): H4(FT)																			
		0.49	0.50	0.51	0.52	0.53	0.54	0.56	0.57	0.58	0.59	0.61	0.62	0.64	0.65	0.67	0.68	0.70	0.72	0.73	0.75
0.70	1.31	1.30	1.29	1.29	1.29	1.28	1.28	1.27	1.26	1.25	1.24	1.22	1.20	1.17	1.13						
0.71	1.34		1.33	1.33	1.32	1.32	1.31	1.31	1.30	1.29	1.28	1.27	1.25	1.22	1.19	1.14					
0.72	1.38			1.36	1.36	1.36	1.35	1.35	1.34	1.33	1.32	1.31	1.29	1.27	1.24	1.20	1.15				
0.73	1.41				1.40	1.39	1.39	1.39	1.38	1.37	1.36	1.35	1.34	1.32	1.29	1.25	1.21				
0.74	1.45				1.44	1.43	1.43	1.42	1.42	1.41	1.40	1.39	1.38	1.36	1.34	1.31	1.27	1.22			
0.75	1.49					1.47	1.47	1.46	1.46	1.45	1.44	1.44	1.42	1.41	1.39	1.36	1.32	1.28			
0.76	1.52					1.51	1.51	1.50	1.50	1.49	1.49	1.48	1.47	1.45	1.43	1.41	1.38	1.34	1.29		
0.77	1.56						1.55	1.54	1.54	1.53	1.53	1.52	1.51	1.50	1.48	1.46	1.43	1.40	1.35		
0.78	1.60							1.58	1.58	1.57	1.57	1.56	1.55	1.54	1.53	1.51	1.48	1.45	1.41	1.36	
0.79	1.64							1.62	1.62	1.61	1.61	1.60	1.59	1.58	1.57	1.55	1.53	1.50	1.47	1.42	1.37

H1 (FT)	Free Flow (CFS)	Submerged flow (CFS): H4(FT)																			
		0.56	0.57	0.58	0.59	0.61	0.62	0.63	0.65	0.66	0.67	0.69	0.70	0.72	0.74	0.75	0.77	0.79	0.81	0.83	0.85
0.80	1.67	1.66	1.66	1.65	1.65	1.64	1.64	1.63	1.62	1.61	1.59	1.57	1.55	1.51	1.47	1.42					
0.81	1.71		1.70	1.69	1.69	1.68	1.68	1.67	1.66	1.65	1.64	1.62	1.60	1.57	1.53	1.48					
0.82	1.75			1.74	1.73	1.73	1.72	1.72	1.71	1.70	1.69	1.67	1.65	1.62	1.59	1.54	1.49				
0.83	1.79			1.78	1.77	1.77	1.76	1.76	1.75	1.74	1.73	1.72	1.70	1.68	1.64	1.61	1.56				
0.84	1.83				1.82	1.81	1.81	1.80	1.80	1.79	1.78	1.77	1.75	1.73	1.70	1.66	1.62	1.56			
0.85	1.88					1.86	1.85	1.85	1.84	1.83	1.82	1.81	1.80	1.78	1.75	1.72	1.68	1.63			
0.86	1.92					1.90	1.90	1.89	1.88	1.88	1.87	1.86	1.85	1.83	1.81	1.78	1.74	1.69	1.63		
0.87	1.96						1.94	1.93	1.93	1.92	1.92	1.91	1.90	1.88	1.86	1.83	1.80	1.76	1.70		
0.88	2.00						1.99	1.98	1.97	1.97	1.96	1.95	1.94	1.93	1.91	1.89	1.86	1.82	1.77	1.71	
0.89	2.05							2.03	2.02	2.01	2.01	2.00	1.99	1.98	1.96	1.94	1.91	1.88	1.83	1.78	1.71

H1 (FT)	Free Flow (CFS)	Submerged flow (CFS): H4(FT)																			
		0.63	0.64	0.65	0.67	0.68	0.69	0.71	0.72	0.74	0.75	0.77	0.79	0.80	0.82	0.84	0.86	0.88	0.90	0.92	0.94
0.90	2.09	2.07	2.07	2.06	2.06	2.05	2.04	2.04	2.03	2.01	1.99	1.97	1.94	1.90	1.86	1.80					
0.91	2.13		2.12	2.11	2.10	2.10	2.09	2.08	2.07	2.06	2.05	2.03	2.00	1.96	1.92	1.87	1.80				
0.92	2.18			2.16	2.15	2.15	2.14	2.13	2.12	2.11	2.10	2.08	2.06	2.02	1.98	1.93	1.87				
0.93	2.22			2.21	2.20	2.19	2.19	2.18	2.17	2.16	2.15	2.13	2.11	2.08	2.05	2.00	1.94	1.87			
0.94	2.27				2.25	2.24	2.24	2.23	2.22	2.21	2.20	2.19	2.17	2.14	2.11	2.07	2.01	1.95			
0.95	2.32				2.30	2.29	2.28	2.28	2.27	2.26	2.25	2.24	2.22	2.20	2.17	2.13	2.08	2.02	1.95		
0.96	2.36					2.34	2.33	2.33	2.32	2.31	2.30	2.29	2.27	2.25	2.23	2.19	2.15	2.09	2.02		
0.97	2.41					2.39	2.38	2.38	2.37	2.36	2.35	2.34	2.33	2.31	2.29	2.25	2.21	2.16	2.10	2.02	
0.98	2.46						2.44	2.43	2.42	2.41	2.41	2.40	2.38	2.37	2.34	2.31	2.28	2.23	2.17	2.10	
0.99	2.51						2.49	2.48	2.47	2.47	2.46	2.45	2.44	2.42	2.40	2.37	2.34	2.30	2.24	2.18	2.10

H1 (FT)	Free Flow (CFS)	Submerged flow (CFS): H4(FT)																			
		0.70	0.71	0.73	0.74	0.76	0.77	0.79	0.80	0.82	0.83	0.85	0.87	0.89	0.91	0.93	0.95	0.97	0.99	1.01	1.04
1.00	2.56	2.54	2.53	2.52	2.52	2.51	2.50	2.49	2.48	2.46	2.44	2.42	2.38	2.34	2.29	2.22	2.14				
1.01	2.60		2.58	2.58	2.57	2.56	2.55	2.54	2.53	2.52	2.50	2.48	2.45	2.41	2.36	2.30	2.22				
1.02	2.65			2.63	2.62	2.61	2.61	2.60	2.59	2.57	2.56	2.54	2.51	2.47	2.43	2.37	2.30				
1.03	2.71			2.68	2.67	2.67	2.66	2.65	2.64	2.63	2.62	2.60	2.57	2.54	2.50	2.44	2.38	2.30			
1.04	2.76				2.73	2.72	2.71	2.71	2.70	2.69	2.67	2.65	2.63	2.60	2.56	2.51	2.45	2.38			
1.05	2.81				2.78	2.78	2.77	2.76	2.75	2.74	2.73	2.71	2.69	2.66	2.63	2.58	2.53	2.46	2.37		
1.06	2.86					2.83	2.82	2.82	2.81	2.80	2.79	2.77	2.75	2.73	2.70	2.65	2.60	2.54	2.46		
1.07	2.91					2.89	2.88	2.87	2.86	2.85	2.84	2.83	2.81	2.79	2.76	2.72	2.67	2.61	2.54	2.45	
1.08	2.97						2.94	2.93	2.92	2.91	2.90	2.89	2.87	2.85	2.82	2.79	2.74	2.69	2.62	2.53	
1.09	3.02						2.99	2.98	2.98	2.97	2.96	2.95	2.93	2.91	2.89	2.86	2.81	2.76	2.70	2.62	2.52

Table 2.—Free- and submerged-flow discharge (cubic feet per second) with water depths h_1 and h_4 measured on 1.25:1 sidewall with sloping gage for trapezoidal flume No. 2 (2-ft bottom approach width, 1-ft bottom throat width, and 1.25:1 sidewall)—Continued

H ₁ (FT)	Free Flow (CFS)	Submerged flow (CFS): H ₄ (FT)																			
		0.77	0.78	0.80	0.81	0.83	0.85	0.86	0.88	0.90	0.91	0.93	0.95	0.97	0.99	1.02	1.04	1.06	1.08	1.11	1.13
1.10	3.07	3.05	3.04	3.03	3.03	3.02	3.01	3.00	2.98	2.97	2.94	2.91	2.88	2.83	2.77	2.69	2.60				
1.11	3.13		3.10	3.09	3.08	3.08	3.07	3.06	3.04	3.03	3.01	2.98	2.94	2.90	2.85	2.78	2.69				
1.12	3.18		3.16	3.15	3.14	3.13	3.13	3.12	3.10	3.09	3.07	3.04	3.01	2.97	2.92	2.86	2.78	2.68			
1.13	3.24			3.21	3.20	3.19	3.18	3.18	3.16	3.15	3.13	3.11	3.08	3.04	3.00	2.94	2.86	2.77			
1.14	3.30			3.27	3.26	3.25	3.24	3.24	3.22	3.21	3.20	3.17	3.15	3.11	3.07	3.01	2.94	2.86			
1.15	3.35				3.32	3.31	3.30	3.30	3.29	3.27	3.26	3.24	3.21	3.18	3.14	3.09	3.02	2.94	2.84		
1.16	3.41				3.38	3.37	3.36	3.36	3.35	3.33	3.32	3.30	3.28	3.25	3.21	3.17	3.10	3.03	2.94		
1.17	3.47					3.43	3.43	3.42	3.41	3.40	3.38	3.37	3.35	3.32	3.28	3.24	3.18	3.11	3.03	2.92	
1.18	3.53					3.50	3.49	3.48	3.47	3.46	3.45	3.43	3.41	3.39	3.36	3.31	3.26	3.19	3.11	3.01	
1.19	3.58						3.55	3.54	3.53	3.52	3.51	3.50	3.48	3.45	3.43	3.39	3.34	3.28	3.20	3.11	3.00

H ₁ (FT)	Free Flow (CFS)	Submerged flow (CFS): H ₄ (FT)																			
		0.84	0.86	0.87	0.89	0.90	0.92	0.94	0.96	0.97	0.99	1.01	1.04	1.06	1.08	1.10	1.13	1.15	1.18	1.20	1.23
1.20	3.64	3.62	3.61	3.60	3.59	3.58	3.57	3.56	3.54	3.52	3.49	3.46	3.42	3.37	3.30	3.22	3.11				
1.21	3.70		3.67	3.66	3.65	3.64	3.63	3.62	3.61	3.59	3.56	3.53	3.49	3.44	3.38	3.30	3.21				
1.22	3.77		3.74	3.73	3.72	3.71	3.70	3.69	3.67	3.65	3.63	3.60	3.57	3.52	3.46	3.39	3.30	3.19			
1.23	3.83			3.79	3.78	3.77	3.76	3.75	3.74	3.72	3.70	3.68	3.64	3.60	3.55	3.48	3.39	3.29			
1.24	3.89			3.86	3.85	3.84	3.83	3.82	3.80	3.79	3.77	3.75	3.72	3.68	3.63	3.56	3.48	3.38	3.26		
1.25	3.95				3.91	3.90	3.89	3.88	3.87	3.86	3.84	3.82	3.79	3.75	3.70	3.64	3.57	3.48	3.37		
1.26	4.01				3.98	3.97	3.96	3.95	3.94	3.92	3.91	3.89	3.86	3.83	3.78	3.73	3.66	3.57	3.46		
1.27	4.08					4.04	4.03	4.02	4.01	3.99	3.98	3.96	3.93	3.90	3.86	3.81	3.74	3.66	3.56	3.44	
1.28	4.14					4.10	4.09	4.08	4.07	4.06	4.05	4.03	4.01	3.98	3.94	3.89	3.83	3.75	3.66	3.54	
1.29	4.21					4.17	4.16	4.15	4.14	4.13	4.12	4.10	4.08	4.05	4.01	3.97	3.91	3.84	3.75	3.64	3.52

H1 (FT)	Free Flow (CFS)	Submerged flow (CFS): H4(FT)																			
		0.91	0.93	0.94	0.96	0.98	1.00	1.01	1.03	1.05	1.07	1.10	1.12	1.14	1.16	1.19	1.21	1.24	1.27	1.29	1.32
1.30	4.27	4.24	4.23	4.22	4.21	4.20	4.18	4.17	4.15	4.13	4.10	4.06	4.02	3.96	3.88	3.79	3.68				
1.31	4.34		4.30	4.29	4.28	4.27	4.25	4.24	4.22	4.20	4.17	4.14	4.10	4.04	3.97	3.88	3.78	3.65			
1.32	4.40		4.37	4.36	4.35	4.34	4.32	4.31	4.29	4.28	4.25	4.22	4.18	4.13	4.06	3.98	3.88	3.75			
1.33	4.47			4.43	4.42	4.41	4.39	4.38	4.37	4.35	4.33	4.30	4.26	4.21	4.15	4.07	3.98	3.86			
1.34	4.54			4.50	4.49	4.48	4.47	4.45	4.44	4.42	4.40	4.37	4.34	4.29	4.23	4.16	4.07	3.96	3.83		
1.35	4.61				4.56	4.55	4.54	4.53	4.51	4.50	4.48	4.45	4.42	4.37	4.32	4.25	4.17	4.06	3.93		
1.36	4.67				4.63	4.62	4.61	4.60	4.58	4.57	4.55	4.53	4.50	4.46	4.41	4.34	4.26	4.16	4.04		
1.37	4.74				4.71	4.69	4.68	4.67	4.66	4.64	4.63	4.60	4.57	4.54	4.49	4.43	4.36	4.26	4.15	4.01	
1.38	4.81					4.77	4.76	4.74	4.73	4.72	4.70	4.68	4.65	4.62	4.57	4.52	4.45	4.36	4.25	4.12	
1.39	4.88					4.84	4.83	4.82	4.81	4.79	4.78	4.76	4.73	4.70	4.66	4.61	4.54	4.46	4.35	4.23	4.08

H1 (FT)	Free Flow (CFS)	Submerged flow (CFS): H4(FT)																			
		0.98	1.00	1.01	1.03	1.05	1.07	1.09	1.11	1.13	1.15	1.18	1.20	1.22	1.25	1.28	1.30	1.33	1.36	1.39	1.42
1.40	4.95	4.92	4.90	4.89	4.88	4.87	4.85	4.84	4.82	4.79	4.76	4.72	4.67	4.60	4.52	4.42	4.29				
1.41	5.03		4.98	4.97	4.96	4.94	4.93	4.91	4.90	4.87	4.84	4.80	4.75	4.69	4.61	4.52	4.40	4.25			
1.42	5.10		5.06	5.04	5.03	5.02	5.01	4.99	4.97	4.95	4.92	4.89	4.84	4.78	4.71	4.62	4.51	4.37			
1.43	5.17			5.12	5.11	5.10	5.08	5.07	5.05	5.03	5.00	4.97	4.93	4.87	4.80	4.72	4.61	4.48			
1.44	5.24			5.20	5.19	5.17	5.16	5.15	5.13	5.11	5.09	5.05	5.01	4.96	4.90	4.82	4.71	4.59	4.44		
1.45	5.32				5.26	5.25	5.24	5.22	5.21	5.19	5.17	5.14	5.10	5.05	4.99	4.91	4.82	4.70	4.56		
1.46	5.39				5.34	5.33	5.32	5.30	5.29	5.27	5.25	5.22	5.19	5.14	5.08	5.01	4.92	4.81	4.67	4.51	
1.47	5.47				5.42	5.41	5.40	5.38	5.37	5.35	5.33	5.30	5.27	5.23	5.18	5.11	5.02	4.91	4.78	4.63	
1.48	5.54					5.49	5.48	5.46	5.45	5.43	5.41	5.39	5.36	5.32	5.27	5.20	5.12	5.02	4.90	4.75	
1.49	5.62					5.57	5.56	5.54	5.53	5.51	5.49	5.47	5.44	5.40	5.36	5.30	5.22	5.12	5.01	4.87	4.70

Table 2.—Free- and submerged-flow discharge (cubic feet per second) with water depths h_1 and h_2 measured on 1.25:1 sidewall with sloping gage for trapezoidal flume No. 2 (2-ft bottom approach width, 1-ft bottom throat width, and 1.25:1 sidewall)—Continued

H1 (FT)	Free Flow (CFS)	Submerged flow (CFS): H4(FT)																			
		1.05	1.07	1.09	1.11	1.13	1.15	1.17	1.19	1.21	1.23	1.26	1.28	1.31	1.34	1.36	1.39	1.42	1.45	1.48	1.51
1.50	5.70	5.65	5.64	5.63	5.61	5.60	5.58	5.56	5.54	5.51	5.48	5.43	5.37	5.30	5.21	5.10	4.96	4.79			
1.51	5.77		5.72	5.71	5.69	5.68	5.67	5.65	5.63	5.60	5.57	5.52	5.47	5.40	5.31	5.21	5.07	4.91			
1.52	5.85		5.80	5.79	5.78	5.76	5.75	5.73	5.71	5.68	5.65	5.61	5.56	5.50	5.42	5.31	5.19	5.03			
1.53	5.93			5.87	5.86	5.85	5.83	5.81	5.79	5.77	5.74	5.70	5.66	5.59	5.52	5.42	5.30	5.15	4.98		
1.54	6.01			5.96	5.94	5.93	5.91	5.90	5.88	5.86	5.83	5.79	5.75	5.69	5.62	5.53	5.41	5.27	5.10		
1.55	6.09			6.04	6.03	6.01	6.00	5.98	5.96	5.94	5.92	5.88	5.84	5.79	5.72	5.63	5.52	5.39	5.23		
1.56	6.17				6.11	6.10	6.08	6.07	6.05	6.03	6.01	5.97	5.93	5.88	5.82	5.74	5.63	5.51	5.35	5.17	
1.57	6.25				6.20	6.18	6.17	6.15	6.14	6.12	6.09	6.06	6.03	5.98	5.92	5.84	5.74	5.62	5.47	5.30	
1.58	6.33					6.27	6.25	6.24	6.22	6.20	6.18	6.15	6.12	6.07	6.02	5.94	5.85	5.73	5.59	5.43	
1.59	6.42					6.36	6.34	6.33	6.31	6.29	6.27	6.24	6.21	6.17	6.11	6.04	5.96	5.85	5.71	5.55	5.36
H1 (FT)	Free Flow (CFS)	Submerged flow (CFS): H4(FT)																			
		1.12	1.14	1.16	1.18	1.20	1.22	1.24	1.27	1.29	1.31	1.34	1.37	1.39	1.42	1.45	1.48	1.51	1.54	1.57	1.61
1.60	6.50	6.45	6.43	6.42	6.40	6.39	6.37	6.35	6.32	6.29	6.25	6.20	6.14	6.06	5.96	5.83	5.68	5.49			
1.61	6.58		6.52	6.51	6.49	6.48	6.46	6.44	6.42	6.39	6.35	6.30	6.24	6.16	6.07	5.95	5.80	5.62			
1.62	6.67		6.61	6.60	6.58	6.57	6.55	6.53	6.51	6.48	6.44	6.40	6.34	6.27	6.18	6.06	5.93	5.75			
1.63	6.75			6.69	6.67	6.65	6.64	6.62	6.60	6.57	6.54	6.49	6.44	6.37	6.29	6.18	6.05	5.88	5.69		
1.64	6.84			6.78	6.76	6.74	6.73	6.71	6.69	6.66	6.63	6.59	6.54	6.48	6.40	6.29	6.17	6.01	5.82		
1.65	6.92			6.87	6.85	6.83	6.82	6.80	6.78	6.76	6.73	6.69	6.64	6.58	6.50	6.41	6.28	6.14	5.96		
1.66	7.01				6.94	6.93	6.91	6.89	6.87	6.85	6.82	6.79	6.74	6.68	6.61	6.52	6.40	6.26	6.09	5.88	
1.67	7.10				7.03	7.02	7.00	6.98	6.97	6.94	6.92	6.88	6.84	6.79	6.72	6.63	6.52	6.38	6.22	6.02	
1.68	7.19				7.13	7.11	7.09	7.08	7.06	7.04	7.01	6.98	6.94	6.89	6.82	6.74	6.63	6.51	6.35	6.16	
1.69	7.27					7.20	7.19	7.17	7.15	7.13	7.11	7.08	7.04	6.99	6.93	6.85	6.75	6.63	6.48	6.29	6.08

H1 (FT)	Free Flow (CFS)	Submerged flow (CFS): H4(FT)																			
		1.19	1.21	1.23	1.25	1.27	1.30	1.32	1.34	1.37	1.39	1.42	1.45	1.48	1.51	1.54	1.57	1.60	1.63	1.67	1.70
1.70	7.36	7.31	7.29	7.27	7.26	7.24	7.22	7.20	7.17	7.13	7.09	7.03	6.96	6.87	6.76	6.63	6.46	6.25			
1.71	7.45		7.39	7.37	7.35	7.33	7.31	7.29	7.27	7.23	7.19	7.14	7.07	6.99	6.88	6.75	6.59	6.39			
1.72	7.54		7.48	7.46	7.45	7.43	7.41	7.39	7.36	7.33	7.29	7.24	7.18	7.10	7.00	6.87	6.72	6.53	6.31		
1.73	7.64			7.56	7.54	7.52	7.51	7.49	7.46	7.43	7.39	7.35	7.29	7.21	7.12	7.00	6.85	6.67	6.45		
1.74	7.73			7.66	7.64	7.62	7.60	7.58	7.56	7.53	7.50	7.45	7.39	7.32	7.23	7.12	6.98	6.80	6.60		
1.75	7.82			7.75	7.74	7.72	7.70	7.68	7.66	7.63	7.60	7.55	7.50	7.43	7.35	7.24	7.10	6.94	6.74		
1.76	7.91				7.83	7.82	7.80	7.78	7.76	7.73	7.70	7.66	7.61	7.54	7.46	7.36	7.23	7.07	6.88	6.65	
1.77	8.01				7.93	7.92	7.90	7.88	7.86	7.83	7.80	7.76	7.71	7.65	7.58	7.48	7.35	7.20	7.02	6.80	
1.78	8.10				8.03	8.01	8.00	7.98	7.96	7.93	7.90	7.87	7.82	7.76	7.69	7.60	7.48	7.33	7.16	6.95	
1.79	8.20					8.11	8.10	8.08	8.06	8.03	8.00	7.97	7.93	7.87	7.80	7.71	7.60	7.46	7.29	7.09	6.85

H1 (FT)	Free Flow (CFS)	Submerged flow (CFS): H4(FT)																			
		1.26	1.28	1.30	1.32	1.35	1.37	1.40	1.42	1.45	1.47	1.50	1.53	1.56	1.59	1.62	1.66	1.69	1.73	1.76	1.80
1.80	8.29	8.23	8.21	8.19	8.17	8.15	8.13	8.10	8.07	8.04	7.99	7.93	7.85	7.75	7.63	7.48	7.30	7.07			
1.81	8.39		8.31	8.29	8.27	8.25	8.23	8.21	8.18	8.14	8.10	8.04	7.96	7.87	7.76	7.61	7.43	7.22			
1.82	8.49		8.41	8.39	8.38	8.36	8.34	8.31	8.28	8.25	8.20	8.15	8.08	7.99	7.88	7.74	7.57	7.37	7.12		
1.83	8.58		8.52	8.50	8.48	8.46	8.44	8.41	8.39	8.35	8.31	8.26	8.19	8.11	8.00	7.87	7.71	7.51	7.27		
1.84	8.68			8.60	8.58	8.56	8.54	8.52	8.49	8.46	8.42	8.37	8.31	8.23	8.13	8.00	7.85	7.66	7.43		
1.85	8.78			8.71	8.69	8.67	8.65	8.62	8.60	8.57	8.53	8.48	8.42	8.35	8.25	8.13	7.98	7.80	7.58		
1.86	8.88			8.81	8.79	8.77	8.75	8.73	8.70	8.67	8.64	8.59	8.54	8.46	8.37	8.26	8.12	7.94	7.73	7.47	
1.87	8.98				8.90	8.88	8.86	8.83	8.81	8.78	8.75	8.70	8.65	8.58	8.50	8.39	8.25	8.08	7.88	7.63	
1.88	9.08				9.00	8.98	8.96	8.94	8.92	8.89	8.86	8.82	8.76	8.70	8.62	8.51	8.38	8.22	8.02	7.79	
1.89	9.18				9.11	9.09	9.07	9.05	9.02	9.00	8.97	8.93	8.88	8.82	8.74	8.64	8.51	8.36	8.17	7.94	7.68

CAST-IN-PLACE CONCRETE TRAPEZOIDAL FLUMES

Table 2.—Free- and submerged-flow discharge (cubic feet per second) with water depths h_1 and h_4 measured on 1.25:1 sidewall with sloping gage for trapezoidal flume No. 2 (2-ft bottom approach width, 1-ft bottom throat width, and 1.25:1 sidewall)—Continued

H1 (FT)	Free Flow (CFS)	Submerged flow (CFS): H4(FT)																			
		1.33	1.35	1.37	1.40	1.42	1.45	1.47	1.50	1.53	1.55	1.58	1.61	1.65	1.68	1.71	1.75	1.78	1.82	1.85	1.89
1.90	9.29	9.22	9.19	9.17	9.15	9.13	9.11	9.08	9.04	9.00	8.95	8.88	8.80	8.69	8.56	8.39	8.19	7.95			
1.91	9.39		9.30	9.28	9.26	9.24	9.22	9.19	9.15	9.11	9.06	9.00	8.92	8.82	8.69	8.53	8.34	8.11			
1.92	9.49		9.41	9.39	9.37	9.35	9.32	9.30	9.27	9.23	9.18	9.12	9.04	8.95	8.82	8.67	8.49	8.26	7.99		
1.93	9.60		9.52	9.50	9.48	9.46	9.43	9.41	9.38	9.34	9.30	9.24	9.16	9.07	8.96	8.81	8.63	8.42	8.15		
1.94	9.70			9.61	9.59	9.57	9.54	9.52	9.49	9.46	9.41	9.36	9.29	9.20	9.09	8.95	8.78	8.57	8.32		
1.95	9.81			9.72	9.70	9.68	9.66	9.63	9.60	9.57	9.53	9.47	9.41	9.32	9.22	9.09	8.92	8.72	8.48		
1.96	9.91			9.84	9.81	9.79	9.77	9.74	9.72	9.68	9.64	9.59	9.53	9.45	9.35	9.22	9.06	8.87	8.64	8.36	
1.97	10.0				9.9	9.9	9.9	9.9	9.8	9.8	9.8	9.7	9.7	9.6	9.5	9.4	9.2	9.0	8.8	8.5	
1.98	10.1				10.0	10.0	10.0	10.0	9.9	9.9	9.9	9.8	9.8	9.7	9.6	9.5	9.3	9.2	8.9	8.7	
1.99	10.2				10.2	10.1	10.1	10.1	10.1	10.0	10.0	9.9	9.9	9.8	9.7	9.6	9.5	9.3	9.1	8.9	8.6

H1 (FT)	Free Flow (CFS)	Submerged flow (CFS): H4(FT)																			
		1.40	1.42	1.45	1.47	1.50	1.52	1.55	1.58	1.60	1.63	1.66	1.70	1.73	1.76	1.80	1.83	1.87	1.91	1.95	1.99
2.00	10.3	10.3	10.2	10.2	10.2	10.2	10.1	10.1	10.1	10.0	10.0	9.9	9.8	9.7	9.5	9.4	9.2	8.9			
2.01	10.5		10.4	10.3	10.3	10.3	10.3	10.2	10.2	10.2	10.1	10.0	9.9	9.8	9.7	9.5	9.3	9.1	8.7		
2.02	10.6		10.5	10.5	10.4	10.4	10.4	10.4	10.3	10.3	10.2	10.2	10.1	10.0	9.8	9.7	9.5	9.2	8.9		
2.03	10.7		10.6	10.6	10.5	10.5	10.5	10.5	10.4	10.4	10.3	10.3	10.2	10.1	10.0	9.8	9.6	9.4	9.1		
2.04	10.8			10.7	10.7	10.6	10.6	10.6	10.6	10.5	10.5	10.4	10.3	10.2	10.1	10.0	9.8	9.5	9.3		
2.05	10.9			10.8	10.8	10.8	10.7	10.7	10.7	10.6	10.6	10.5	10.5	10.4	10.2	10.1	9.9	9.7	9.4	9.1	
2.06	11.0			10.9	10.9	10.9	10.9	10.8	10.8	10.8	10.7	10.6	10.5	10.4	10.2	10.1	9.9	9.6	9.3		
2.07	11.1				11.0	11.0	11.0	10.9	10.9	10.9	10.8	10.8	10.7	10.6	10.5	10.4	10.2	10.0	9.8	9.5	
2.08	11.2				11.1	11.1	11.1	11.1	11.0	11.0	11.0	10.9	10.8	10.8	10.7	10.5	10.4	10.2	9.9	9.6	
2.09	11.4				11.3	11.2	11.2	11.2	11.2	11.1	11.1	11.0	11.0	10.9	10.8	10.7	10.5	10.3	10.1	9.8	9.5

H1 (FT)	Free Flow (CFS)	Submerged flow (CFS): H4(FT)																			
		1.47	1.49	1.52	1.54	1.57	1.60	1.62	1.65	1.68	1.71	1.75	1.78	1.81	1.85	1.89	1.92	1.96	2.00	2.04	2.08
2.10	11.5	11.4	11.4	11.3	11.3	11.3	11.3	11.2	11.2	11.1	11.1	11.0	10.9	10.8	10.6	10.4	10.2	9.9			
2.11	11.6		11.5	11.5	11.4	11.4	11.4	11.3	11.3	11.3	11.2	11.1	11.0	10.9	10.8	10.6	10.3	10.1	9.7		
2.12	11.7		11.6	11.6	11.6	11.5	11.5	11.5	11.4	11.4	11.3	11.3	11.2	11.0	10.9	10.7	10.5	10.2	9.9		
2.13	11.8		11.7	11.7	11.7	11.7	11.6	11.6	11.6	11.5	11.5	11.4	11.3	11.2	11.1	10.9	10.7	10.4	10.1		
2.14	11.9			11.8	11.8	11.8	11.8	11.7	11.7	11.6	11.6	11.5	11.4	11.3	11.2	11.0	10.8	10.6	10.3		
2.15	12.1			12.0	11.9	11.9	11.9	11.8	11.8	11.8	11.7	11.7	11.6	11.5	11.3	11.2	11.0	10.7	10.5	10.1	
2.16	12.2			12.1	12.1	12.0	12.0	12.0	11.9	11.9	11.9	11.8	11.7	11.6	11.5	11.3	11.1	10.9	10.6	10.3	
2.17	12.3				12.2	12.2	12.1	12.1	12.1	12.0	12.0	11.9	11.9	11.8	11.6	11.5	11.3	11.1	10.8	10.5	
2.18	12.4				12.3	12.3	12.3	12.2	12.2	12.2	12.1	12.1	12.0	11.9	11.8	11.6	11.5	11.2	11.0	10.7	
2.19	12.6				12.4	12.4	12.4	12.4	12.3	12.3	12.2	12.2	12.1	12.0	11.9	11.8	11.6	11.4	11.2	10.9	10.5

H1 (FT)	Free Flow (CFS)	Submerged flow (CFS): H4(FT)																				
		1.54	1.56	1.59	1.62	1.64	1.67	1.70	1.73	1.76	1.79	1.83	1.86	1.90	1.93	1.97	2.01	2.05	2.09	2.13	2.18	
2.20	12.7	12.6	12.6	12.5	12.5	12.5	12.4	12.4	12.4	12.3	12.2	12.1	12.0	11.9	11.7	11.5	11.3	10.9				
2.21	12.8		12.7	12.7	12.6	12.6	12.6	12.5	12.5	12.4	12.4	12.3	12.2	12.0	11.9	11.7	11.4	11.1	10.8			
2.22	12.9		12.8	12.8	12.8	12.7	12.7	12.7	12.6	12.6	12.5	12.4	12.3	12.2	12.0	11.8	11.6	11.3	11.0			
2.23	13.1		12.9	12.9	12.9	12.9	12.8	12.8	12.8	12.7	12.6	12.6	12.5	12.3	12.2	12.0	11.8	11.5	11.2			
2.24	13.2			13.0	13.0	13.0	13.0	12.9	12.9	12.8	12.8	12.7	12.6	12.5	12.4	12.2	11.9	11.7	11.3			
2.25	13.3			13.2	13.2	13.1	13.1	13.1	13.0	13.0	12.9	12.9	12.8	12.7	12.5	12.3	12.1	11.9	11.5	11.2		
2.26	13.4			13.3	13.3	13.3	13.2	13.2	13.2	13.1	13.1	13.0	12.9	12.8	12.7	12.5	12.3	12.0	11.7	11.4		
2.27	13.6			13.5	13.4	13.4	13.4	13.3	13.3	13.3	13.2	13.1	13.1	13.0	12.8	12.7	12.5	12.2	11.9	11.6		
2.28	13.7				13.6	13.5	13.5	13.5	13.5	13.4	13.4	13.3	13.3	13.2	13.1	13.0	12.8	12.6	12.4	12.1	11.7	
2.29	13.8				13.7	13.7	13.6	13.6	13.6	13.6	13.5	13.5	13.4	13.3	13.2	13.1	13.0	12.8	12.6	12.3	11.9	11.6

Table 2.—Free- and submerged-flow discharge (cubic feet per second) with water depths h_1 and h_2 measured on 1.25:1 sidewall with sloping gage for trapezoidal flume No. 2 (2-ft bottom approach width, 1-ft bottom throat width, and 1.25:1 sidewall)—Continued

H1 (FT)	Free Flow (CFS)	Submerged flow (CFS): H4 (FT)																			
		1.61	1.64	1.66	1.69	1.72	1.75	1.78	1.81	1.84	1.87	1.91	1.94	1.98	2.02	2.06	2.10	2.14*	2.18	2.23	2.27
2.30	13.9	13.8	13.8	13.8	13.7	13.7	13.7	13.6	13.6	13.5	13.5	13.4	13.2	13.1	12.9	12.7	12.4	12.1	11.7		
2.31	14.1		13.9	13.9	13.9	13.9	13.8	13.8	13.7	13.7	13.6	13.5	13.4	13.3	13.1	12.9	12.6	12.3	11.9		
2.32	14.2		14.1	14.1	14.0	14.0	14.0	13.9	13.9	13.8	13.8	13.7	13.6	13.4	13.2	13.0	12.8	12.5	12.1		
2.33	14.3		14.2	14.2	14.2	14.1	14.1	14.1	14.0	14.0	13.9	13.8	13.7	13.6	13.4	13.2	13.0	12.6	12.3		
2.34	14.5			14.3	14.3	14.3	14.2	14.2	14.2	14.1	14.0	14.0	13.9	13.7	13.6	13.4	13.1	12.8	12.5		
2.35	14.6			14.5	14.4	14.4	14.4	14.3	14.3	14.3	14.2	14.1	14.0	13.9	13.7	13.6	13.3	13.0	12.7	12.3	
2.36	14.7			14.6	14.6	14.6	14.5	14.5	14.4	14.4	14.3	14.3	14.2	14.1	13.9	13.7	13.5	13.2	12.9	12.5	
2.37	14.9			14.8	14.7	14.7	14.7	14.6	14.6	14.5	14.5	14.4	14.3	14.2	14.1	13.9	13.7	13.4	13.1	12.7	
2.38	15.0				14.9	14.8	14.8	14.8	14.7	14.7	14.6	14.6	14.5	14.4	14.2	14.1	13.8	13.6	13.3	12.9	
2.39	15.2				15.0	15.0	14.9	14.9	14.9	14.8	14.8	14.7	14.6	14.5	14.4	14.2	14.0	13.8	13.5	13.1	12.7

H1 (FT)	Free Flow (CFS)	Submerged flow (CFS): H4 (FT)																				
		1.68	1.71	1.73	1.76	1.79	1.82	1.85	1.89	1.92	1.95	1.99	2.03	2.07	2.11	2.15	2.19	2.23	2.28	2.32	2.37	
2.40	15.3	15.2	15.1	15.1	15.1	15.0	15.0	15.0	14.9	14.8	14.8	14.7	14.5	14.4	14.2	13.9	13.6	13.3	12.8			
2.41	15.4		15.3	15.3	15.2	15.2	15.1	15.1	15.1	15.0	14.9	14.8	14.7	14.5	14.3	14.1	13.8	13.5	13.0			
2.42	15.6		15.4	15.4	15.4	15.3	15.3	15.3	15.2	15.1	15.1	15.0	14.9	14.7	14.5	14.3	14.0	13.7	13.3			
2.43	15.7		15.6	15.5	15.5	15.5	15.4	15.4	15.4	15.3	15.2	15.1	15.0	14.9	14.7	14.5	14.2	13.9	13.5			
2.44	15.9			15.7	15.7	15.6	15.6	15.6	15.5	15.4	15.4	15.3	15.2	15.0	14.9	14.7	14.4	14.1	13.7			
2.45	16.0				15.8	15.8	15.8	15.7	15.7	15.7	15.6	15.5	15.4	15.3	15.2	15.0	14.8	14.6	14.3	13.9	13.4	
2.46	16.1				16.0	16.0	15.9	15.9	15.8	15.8	15.8	15.7	15.6	15.5	15.4	15.2	15.0	14.8	14.5	14.1	13.7	
2.47	16.3				16.1	16.1	16.1	16.0	16.0	16.0	15.9	15.8	15.8	15.7	15.5	15.4	15.2	15.0	14.7	14.3	13.9	
2.48	16.4					16.3	16.2	16.2	16.2	16.1	16.1	16.0	15.9	15.8	15.7	15.6	15.4	15.1	14.9	14.5	14.1	
2.49	16.6					16.4	16.4	16.3	16.3	16.3	16.2	16.2	16.1	16.0	15.9	15.7	15.6	15.3	15.1	14.7	14.3	13.8

H1 (FT)	Free Flow (CFS)	Submerged flow (CFS): H4(FT)																				
		1.75	1.78	1.81	1.84	1.87	1.90	1.93	1.96	2.00	2.03	2.07	2.11	2.15	2.19	2.23	2.28	2.32	2.37	2.41	2.46	
2.50	16.7	16.6	16.5	16.5	16.5	16.4	16.4	16.3	16.3	16.2	16.1	16.0	15.9	15.7	15.5	15.2	14.9	14.5	14.1			
2.51	16.9		16.7	16.7	16.6	16.6	16.6	16.5	16.4	16.4	16.3	16.2	16.1	15.9	15.7	15.4	15.1	14.7	14.3			
2.52	17.0		16.9	16.8	16.8	16.7	16.7	16.7	16.6	16.5	16.5	16.4	16.2	16.1	15.9	15.6	15.3	14.9	14.5			
2.53	17.2		17.0	17.0	16.9	16.9	16.9	16.8	16.8	16.7	16.6	16.5	16.4	16.2	16.1	15.8	15.5	15.2	14.7			
2.54	17.3			17.1	17.1	17.1	17.0	17.0	16.9	16.9	16.8	16.7	16.6	16.4	16.2	16.0	15.7	15.4	14.9			
2.55	17.5			17.3	17.3	17.2	17.2	17.1	17.1	17.0	16.9	16.9	16.7	16.6	16.4	16.2	15.9	15.6	15.2	14.7		
2.56	17.6			17.4	17.4	17.4	17.3	17.3	17.2	17.2	17.1	17.0	16.9	16.8	16.6	16.4	16.1	15.8	15.4	14.9		
2.57	17.8			17.6	17.6	17.5	17.5	17.4	17.4	17.3	17.3	17.2	17.1	17.0	16.8	16.6	16.3	16.0	15.6	15.1		
2.58	17.9			17.8	17.7	17.7	17.6	17.6	17.6	17.5	17.4	17.4	17.3	17.1	17.0	16.8	16.5	16.2	15.8	15.4		
2.59	18.1			17.9	17.8	17.8	17.8	17.7	17.7	17.6	17.5	17.4	17.3	17.1	16.9	16.7	16.4	16.0	15.6	15.1		

H1 (FT)	Free Flow (CFS)	Submerged flow (CFS): H4(FT)																				
		1.82	1.85	1.88	1.91	1.94	1.97	2.01	2.04	2.08	2.11	2.15	2.19	2.23	2.28	2.32	2.37	2.41	2.46	2.51	2.56	
2.60	18.2	18.1	18.0	18.0	18.0	17.9	17.9	17.8	17.8	17.7	17.6	17.5	17.3	17.1	16.9	16.6	16.3	15.8	15.3			
2.61	18.4		18.2	18.2	18.1	18.1	18.0	18.0	17.9	17.8	17.8	17.6	17.5	17.3	17.1	16.8	16.5	16.1	15.6			
2.62	18.5		18.4	18.3	18.3	18.2	18.2	18.1	18.1	18.0	17.9	17.8	17.7	17.5	17.3	17.0	16.7	16.3	15.8			
2.63	18.7		18.5	18.5	18.4	18.4	18.4	18.3	18.2	18.2	18.1	18.0	17.9	17.7	17.5	17.2	16.9	16.5	16.0			
2.64	18.8		18.7	18.6	18.6	18.6	18.5	18.5	18.4	18.3	18.3	18.2	18.0	17.9	17.7	17.4	17.1	16.7	16.3	15.7		
2.65	19.0			18.8	18.8	18.7	18.7	18.6	18.6	18.5	18.4	18.3	18.2	18.1	17.9	17.6	17.3	17.0	16.5	16.0		
2.66	19.1			19.0	18.9	18.9	18.8	18.8	18.7	18.7	18.6	18.5	18.4	18.2	18.1	17.8	17.5	17.2	16.7	16.2		
2.67	19.3			19.1	19.1	19.1	19.0	19.0	18.9	18.9	18.8	18.7	18.6	18.4	18.2	18.0	17.7	17.4	17.0	16.5		
2.68	19.5			19.3	19.3	19.2	19.2	19.1	19.1	19.0	19.0	18.9	18.8	18.6	18.4	18.2	17.9	17.6	17.2	16.7		
2.69	19.6			19.4	19.4	19.3	19.3	19.3	19.2	19.1	19.0	18.9	18.8	18.6	18.4	18.1	17.8	17.4	17.0	16.4		

Table 2.—Free- and submerged-flow discharge (cubic feet per second) with water depths h_1 and h_4 measured on 1.25:1 sidewall with sloping gage for trapezoidal flume No. 2 (2-ft bottom approach width, 1-ft bottom throat width, and 1.25:1 sidewall)—Continued

H1 (FT)	Free Flow (CFS)	Submerged flow (CFS): H4(FT)																			
		1.89	1.92	1.95	1.98	2.01	2.05	2.08	2.12	2.16	2.19	2.23	2.27	2.32	2.36	2.41	2.45	2.50	2.55	2.60	2.65
2.70	19.8	19.6	19.6	19.5	19.5	19.5	19.4	19.4	19.3	19.2	19.1	19.0	18.8	18.6	18.4	18.1	17.7	17.2	16.7		
2.71	19.9		19.8	19.7	19.7	19.6	19.6	19.5	19.5	19.4	19.3	19.2	19.0	18.8	18.6	18.3	17.9	17.5	17.0		
2.72	20.1		19.9	19.9	19.8	19.8	19.8	19.7	19.6	19.6	19.5	19.3	19.2	19.0	18.8	18.5	18.1	17.7	17.2		
2.73	20.3		20.1	20.1	20.0	20.0	19.9	19.9	19.8	19.7	19.6	19.5	19.4	19.2	19.0	18.7	18.4	17.9	17.4		
2.74	20.4		20.3	20.2	20.2	20.1	20.1	20.0	20.0	19.9	19.8	19.7	19.6	19.4	19.2	18.9	18.6	18.2	17.7	17.1	
2.75	20.6			20.4	20.4	20.3	20.3	20.2	20.2	20.1	20.0	19.9	19.8	19.6	19.4	19.1	18.8	18.4	17.9	17.4	
2.76	20.8			20.6	20.5	20.5	20.4	20.4	20.3	20.3	20.2	20.1	20.0	19.8	19.6	19.3	19.0	18.6	18.2	17.6	
2.77	20.9			20.8	20.7	20.7	20.6	20.6	20.5	20.4	20.4	20.3	20.1	20.0	19.8	19.5	19.2	18.9	18.4	17.9	
2.78	21.1			20.9	20.9	20.8	20.8	20.7	20.7	20.6	20.5	20.4	20.3	20.2	20.0	19.7	19.4	19.1	18.6	18.1	
2.79	21.3				21.1	21.0	21.0	20.9	20.9	20.8	20.7	20.6	20.5	20.4	20.2	20.0	19.7	19.3	18.9	18.4	17.8

H1 (FT)	Free Flow (CFS)	Submerged flow (CFS): H4(FT)																			
		1.96	1.99	2.02	2.06	2.09	2.12	2.16	2.20	2.23	2.27	2.32	2.36	2.40	2.45	2.49	2.54	2.59	2.64	2.69	2.75
2.80	21.4	21.3	21.2	21.2	21.1	21.1	21.0	21.0	20.9	20.8	20.7	20.6	20.4	20.2	19.9	19.6	19.2	18.7	18.1		
2.81	21.6		21.4	21.4	21.3	21.3	21.2	21.2	21.1	21.0	20.9	20.8	20.6	20.4	20.1	19.8	19.4	19.0	18.4		
2.82	21.8		21.6	21.5	21.5	21.4	21.4	21.3	21.3	21.2	21.1	21.0	20.8	20.6	20.3	20.0	19.7	19.2	18.6		
2.83	22.0		21.8	21.7	21.7	21.6	21.6	21.5	21.5	21.4	21.3	21.1	21.0	20.8	20.6	20.3	19.9	19.4	18.9		
2.84	22.1		21.9	21.9	21.9	21.8	21.8	21.7	21.6	21.6	21.5	21.3	21.2	21.0	20.8	20.5	20.1	19.7	19.2	18.5	
2.85	22.3			22.1	22.0	22.0	21.9	21.9	21.8	21.7	21.6	21.5	21.4	21.2	21.0	20.7	20.3	19.9	19.4	18.8	
2.86	22.5			22.3	22.2	22.2	22.1	22.1	22.0	21.9	21.8	21.7	21.6	21.4	21.2	20.9	20.6	20.2	19.7	19.1	
2.87	22.6			22.4	22.4	22.4	22.3	22.2	22.2	22.1	22.0	21.9	21.8	21.6	21.4	21.1	20.8	20.4	19.9	19.3	
2.88	22.8			22.6	22.6	22.5	22.5	22.4	22.4	22.3	22.2	22.1	22.0	21.8	21.6	21.4	21.0	20.6	20.2	19.6	
2.89	23.0				22.8	22.7	22.7	22.6	22.6	22.5	22.4	22.3	22.2	22.0	21.8	21.6	21.3	20.9	20.4	19.9	19.2

H1 (FT)	Free Flow (CFS)	Submerged flow (CFS): H4(FT)																			
		2.03	2.06	2.09	2.13	2.16	2.20	2.24	2.27	2.31	2.35	2.40	2.44	2.49	2.53	2.58	2.63	2.68	2.73	2.79	2.84
2.90	23.2	23.0	22.9	22.9	22.8	22.8	22.7	22.7	22.6	22.5	22.4	22.2	22.1	21.8	21.5	21.2	20.8	20.3	19.6		
2.91	23.4		23.1	23.1	23.0	23.0	22.9	22.9	22.8	22.7	22.6	22.4	22.3	22.0	21.8	21.4	21.0	20.5	19.9		
2.92	23.5		23.3	23.3	23.2	23.2	23.1	23.1	23.0	22.9	22.8	22.6	22.5	22.3	22.0	21.7	21.3	20.8	20.2		
2.93	23.7		23.5	23.5	23.4	23.4	23.3	23.2	23.2	23.1	23.0	22.8	22.7	22.5	22.2	21.9	21.5	21.0	20.4		
2.94	23.9		23.7	23.6	23.6	23.5	23.5	23.4	23.4	23.3	23.2	23.0	22.9	22.7	22.4	22.1	21.7	21.3	20.7	20.0	
2.95	24.1			23.8	23.8	23.7	23.7	23.6	23.6	23.5	23.4	23.2	23.1	22.9	22.7	22.4	22.0	21.5	21.0	20.3	
2.96	24.3			24.0	24.0	23.9	23.9	23.8	23.7	23.7	23.6	23.5	23.3	23.1	22.9	22.6	22.2	21.8	21.2	20.6	
2.97	24.4			24.2	24.2	24.1	24.1	24.0	23.9	23.9	23.8	23.7	23.5	23.3	23.1	22.8	22.5	22.0	21.5	20.9	
2.98	24.6			24.4	24.4	24.3	24.3	24.2	24.1	24.1	24.0	23.9	23.7	23.5	23.3	23.0	22.7	22.3	21.8	21.2	
2.99	24.8			24.6	24.6	24.5	24.4	24.4	24.3	24.3	24.2	24.1	23.9	23.7	23.5	23.3	22.9	22.5	22.0	21.4	20.7

H1 (FT)	Free Flow (CFS)	Submerged flow (CFS): H4(FT)																			
		2.10	2.13	2.17	2.20	2.24	2.27	2.31	2.35	2.39	2.43	2.48	2.52	2.57	2.62	2.67	2.72	2.77	2.83	2.88	2.94
3.00	25.0	24.8	24.7	24.7	24.6	24.6	24.5	24.5	24.4	24.3	24.1	24.0	23.8	23.6	23.3	22.9	22.4	21.9	21.2		
3.01	25.2		24.9	24.9	24.8	24.8	24.7	24.7	24.6	24.5	24.4	24.2	24.0	23.8	23.5	23.1	22.7	22.1	21.5		
3.02	25.4		25.1	25.1	25.0	25.0	24.9	24.8	24.8	24.7	24.6	24.4	24.2	24.0	23.7	23.4	22.9	22.4	21.8		
3.03	25.6		25.3	25.3	25.2	25.2	25.1	25.0	25.0	24.9	24.8	24.6	24.4	24.2	23.9	23.6	23.2	22.7	22.0		
3.04	25.7		25.5	25.5	25.4	25.4	25.3	25.2	25.2	25.1	25.0	24.8	24.7	24.4	24.2	23.8	23.4	22.9	22.3	21.6	
3.05	25.9			25.7	25.6	25.6	25.5	25.4	25.4	25.3	25.2	25.0	24.9	24.7	24.4	24.1	23.7	23.2	22.6	21.9	
3.06	26.1			25.9	25.8	25.8	25.7	25.6	25.6	25.5	25.4	25.3	25.1	24.9	24.6	24.3	23.9	23.5	22.9	22.2	
3.07	26.3			26.1	26.0	26.0	25.9	25.8	25.8	25.7	25.6	25.5	25.3	25.1	24.9	24.6	24.2	23.7	23.2	22.5	
3.08	26.5			26.3	26.2	26.2	26.1	26.0	26.0	25.9	25.8	25.7	25.5	25.3	25.1	24.8	24.4	24.0	23.4	22.8	
3.09	26.7			26.5	26.4	26.4	26.3	26.3	26.2	26.1	26.0	25.9	25.7	25.6	25.3	25.0	24.7	24.2	23.7	23.1	22.3

CAST-IN-PLACE CONCRETE TRAPEZOIDAL FLUMES

Table 2.—Free- and submerged-flow discharge (cubic feet per second) with water depths h_1 and h_4 measured on 1.25:1 sidewall with sloping gage for trapezoidal flume No. 2 (2-ft bottom approach width, 1-ft bottom throat width, and 1.25:1 sidewall)—Continued

H1 (FT)	Free Flow (CFS)	Submerged flow (CFS): H4(FT)																			
		2.17	2.20	2.24	2.27	2.31	2.35	2.39	2.43	2.47	2.51	2.56	2.61	2.65	2.70	2.76	2.81	2.86	2.92	2.97	3.03
3.10	26.9	26.7	26.6	26.6	26.5	26.5	26.4	26.3	26.2	26.1	26.0	25.8	25.6	25.4	25.0	24.6	24.1	23.6	22.9		
3.11	27.1		26.8	26.8	26.7	26.7	26.6	26.5	26.4	26.3	26.2	26.0	25.8	25.6	25.3	24.9	24.4	23.8	23.1		
3.12	27.3		27.0	27.0	26.9	26.9	26.8	26.7	26.6	26.5	26.4	26.3	26.1	25.8	25.5	25.1	24.7	24.1	23.4		
3.13	27.5		27.2	27.2	27.1	27.1	27.0	26.9	26.9	26.8	26.6	26.5	26.3	26.1	25.8	25.4	24.9	24.4	23.7		
3.14	27.7		27.5	27.4	27.3	27.3	27.2	27.1	27.1	27.0	26.8	26.7	26.5	26.3	26.0	25.6	25.2	24.7	24.0	23.3	
3.15	27.9			27.6	27.5	27.5	27.4	27.4	27.3	27.2	27.1	26.9	26.7	26.5	26.2	25.9	25.5	24.9	24.3	23.6	
3.16	28.1			27.8	27.8	27.7	27.6	27.6	27.5	27.4	27.3	27.1	27.0	26.8	26.5	26.1	25.7	25.2	24.6	23.9	
3.17	28.3			28.0	28.0	27.9	27.8	27.8	27.7	27.6	27.5	27.4	27.2	27.0	26.7	26.4	26.0	25.5	24.9	24.2	
3.18	28.5			28.2	28.2	28.1	28.0	28.0	27.9	27.8	27.7	27.6	27.4	27.2	27.0	26.6	26.2	25.7	25.2	24.5	
3.19	28.7			28.4	28.4	28.3	28.3	28.2	28.1	28.0	27.9	27.8	27.6	27.4	27.2	26.9	26.5	26.0	25.4	24.8	24.0

H1 (FT)	Free Flow (CFS)	Submerged flow (CFS): H4(FT)																			
		2.24	2.27	2.31	2.35	2.39	2.42	2.46	2.51	2.55	2.59	2.64	2.69	2.74	2.79	2.84	2.90	2.95	3.01	3.07	3.13
3.20	28.9	28.7	28.6	28.5	28.5	28.4	28.3	28.3	28.2	28.1	27.9	27.7	27.5	27.2	26.9	26.5	26.0	25.3	24.6		
3.21	29.1		28.8	28.7	28.7	28.6	28.6	28.5	28.4	28.3	28.1	28.0	27.7	27.5	27.1	26.7	26.2	25.6	24.9		
3.22	29.3		29.0	29.0	28.9	28.8	28.8	28.7	28.6	28.5	28.4	28.2	28.0	27.7	27.4	27.0	26.5	25.9	25.2		
3.23	29.5		29.2	29.2	29.1	29.1	29.0	28.9	28.8	28.7	28.6	28.4	28.2	28.0	27.6	27.3	26.8	26.2	25.5	24.7	
3.24	29.7		29.5	29.4	29.3	29.3	29.2	29.1	29.0	28.9	28.8	28.7	28.5	28.2	27.9	27.5	27.0	26.5	25.8	25.0	
3.25	29.9			29.6	29.5	29.5	29.4	29.3	29.3	29.2	29.0	28.9	28.7	28.5	28.2	27.8	27.3	26.8	26.1	25.3	
3.26	30.1			29.8	29.8	29.7	29.6	29.6	29.5	29.4	29.3	29.1	28.9	28.7	28.4	28.0	27.6	27.0	26.4	25.6	
3.27	30.3			30.0	30.0	29.9	29.9	29.8	29.7	29.6	29.5	29.3	29.2	28.9	28.6	28.3	27.9	27.3	26.7	25.9	
3.28	30.5			30.3	30.2	30.1	30.1	30.0	29.9	29.8	29.7	29.6	29.4	29.2	28.9	28.6	28.1	27.6	27.0	26.2	
3.29	30.7			30.5	30.4	30.4	30.3	30.2	30.1	30.0	29.9	29.8	29.6	29.4	29.1	28.8	28.4	27.9	27.3	26.5	25.7

H1 (FT)	Free Flow (CFS)	Submerged flow (CFS): H4(FT)																			
		2.31	2.35	2.38	2.42	2.46	2.50	2.54	2.58	2.63	2.67	2.72	2.77	2.82	2.87	2.93	2.99	3.04	3.10	3.16	3.22
3.30	31.0	30.7	30.6	30.6	30.5	30.5	30.4	30.3	30.2	30.1	29.9	29.7	29.5	29.2	28.8	28.4	27.8	27.2	26.4		
3.31	31.2		30.9	30.8	30.7	30.7	30.6	30.5	30.4	30.3	30.2	30.0	29.7	29.5	29.1	28.7	28.1	27.5	26.7		
3.32	31.4		31.1	31.0	31.0	30.9	30.8	30.7	30.6	30.5	30.4	30.2	30.0	29.7	29.4	28.9	28.4	27.8	27.0		
3.33	31.6		31.3	31.3	31.2	31.1	31.0	31.0	30.9	30.8	30.6	30.4	30.2	30.0	29.6	29.2	28.7	28.1	27.3	26.4	
3.34	31.8		31.5	31.5	31.4	31.3	31.3	31.2	31.1	31.0	30.9	30.7	30.5	30.2	29.9	29.5	29.0	28.4	27.6	26.8	
3.35	32.0		31.8	31.7	31.6	31.6	31.5	31.4	31.3	31.2	31.1	30.9	30.7	30.5	30.1	29.7	29.3	28.7	27.9	27.1	
3.36	32.2			31.9	31.9	31.8	31.7	31.6	31.6	31.5	31.3	31.2	31.0	30.7	30.4	30.0	29.5	29.0	28.3	27.4	
3.37	32.5			32.2	32.1	32.0	32.0	31.9	31.8	31.7	31.6	31.4	31.2	31.0	30.7	30.3	29.8	29.3	28.6	27.8	
3.38	32.7			32.4	32.3	32.2	32.2	32.1	32.0	31.9	31.8	31.6	31.5	31.2	30.9	30.6	30.1	29.5	28.9	28.1	
3.39	32.9			32.6	32.5	32.5	32.4	32.3	32.2	32.1	32.0	31.9	31.7	31.5	31.2	30.8	30.4	29.8	29.2	28.4	27.5

H1 (FT)	Free Flow (CFS)	Submerged flow (CFS): H4(FT)																			
		2.38	2.42	2.45	2.49	2.53	2.57	2.62	2.66	2.71	2.75	2.80	2.85	2.91	2.96	3.02	3.07	3.13	3.19	3.25	3.32
3.40	33.1	32.9	32.8	32.7	32.6	32.6	32.5	32.4	32.3	32.2	32.0	31.8	31.6	31.3	30.9	30.4	29.8	29.1	28.3		
3.41	33.3		33.0	32.9	32.9	32.8	32.7	32.6	32.5	32.4	32.3	32.1	31.8	31.5	31.1	30.7	30.1	29.4	28.6		
3.42	33.6		33.3	33.2	33.1	33.0	33.0	32.9	32.8	32.7	32.5	32.3	32.1	31.8	31.4	31.0	30.4	29.7	28.9		
3.43	33.8		33.5	33.4	33.3	33.3	33.2	33.1	33.0	32.9	32.7	32.6	32.3	32.0	31.7	31.2	30.7	30.0	29.2	28.3	
3.44	34.0		33.7	33.6	33.6	33.5	33.4	33.3	33.2	33.1	33.0	32.8	32.6	32.3	32.0	31.5	31.0	30.3	29.6	28.6	
3.45	34.2		34.0	33.9	33.8	33.7	33.7	33.6	33.5	33.4	33.2	33.1	32.8	32.6	32.2	31.8	31.3	30.6	29.9	29.0	
3.46	34.5			34.1	34.0	34.0	33.9	33.8	33.7	33.6	33.5	33.3	33.1	32.8	32.5	32.1	31.6	31.0	30.2	29.3	
3.47	34.7			34.4	34.3	34.2	34.1	34.1	34.0	33.9	33.7	33.6	33.3	33.1	32.8	32.4	31.9	31.3	30.5	29.7	
3.48	34.9			34.6	34.5	34.5	34.4	34.3	34.2	34.1	34.0	33.8	33.6	33.4	33.0	32.6	32.2	31.6	30.8	30.0	
3.49	35.1			34.8	34.8	34.7	34.6	34.5	34.4	34.3	34.2	34.1	33.9	33.6	33.3	32.9	32.4	31.9	31.2	30.3	29.4

Table 2.—Free- and submerged-flow discharge (cubic feet per second) with water depths h_1 and h_2 measured on 1.25:1 sidewall with sloping gage for trapezoidal flume No. 2 (2-ft bottom approach width, 1-ft bottom throat width, and 1.25:1 sidewall)—Continued

H1 (FT)	Free Flow (CFS)	Submerged flow (CFS): H4(FT)																			
		2.45	2.49	2.53	2.57	2.61	2.65	2.69	2.74	2.79	2.83	2.88	2.94	2.99	3.05	3.10	3.16	3.22	3.28	3.35	3.41
3.50	35.4	35.1	35.0	34.9	34.9	34.8	34.7	34.6	34.5	34.4	34.2	34.0	33.7	33.4	33.0	32.5	31.8	31.1	30.2		
3.51	35.6		35.3	35.2	35.1	35.0	34.9	34.9	34.7	34.6	34.4	34.2	34.0	33.7	33.3	32.8	32.2	31.4	30.5		
3.52	35.8		35.5	35.4	35.4	35.3	35.2	35.1	35.0	34.9	34.7	34.5	34.2	33.9	33.5	33.1	32.5	31.7	30.9		
3.53	36.1		35.7	35.7	35.6	35.5	35.4	35.3	35.2	35.1	35.0	34.8	34.5	34.2	33.8	33.4	32.8	32.1	31.2	30.2	
3.54	36.3		36.0	35.9	35.8	35.8	35.7	35.6	35.5	35.4	35.2	35.0	34.8	34.5	34.1	33.6	33.1	32.4	31.6	30.6	
3.55	36.5		36.2	36.2	36.1	36.0	35.9	35.8	35.7	35.6	35.5	35.3	35.0	34.8	34.4	33.9	33.4	32.7	31.9	30.9	
3.56	36.8			36.4	36.3	36.2	36.2	36.1	36.0	35.9	35.7	35.5	35.3	35.0	34.7	34.2	33.7	33.0	32.2	31.3	
3.57	37.0			36.7	36.6	36.5	36.4	36.3	36.2	36.1	36.0	35.8	35.6	35.3	34.9	34.5	34.0	33.3	32.6	31.6	
3.58	37.2			36.9	36.8	36.7	36.7	36.6	36.5	36.4	36.2	36.1	35.8	35.6	35.2	34.8	34.3	33.7	32.9	32.0	
3.59	37.5			37.1	37.1	37.0	36.9	36.8	36.7	36.6	36.5	36.3	36.1	35.8	35.5	35.1	34.6	34.0	33.2	32.3	31.3

H1 (FT)	Free Flow (CFS)	Submerged flow (CFS): H4(FT)																			
		2.52	2.56	2.60	2.64	2.68	2.73	2.77	2.82	2.86	2.91	2.97	3.02	3.07	3.13	3.19	3.25	3.31	3.38	3.44	3.51
3.60	37.7	37.4	37.3	37.3	37.2	37.1	37.0	36.9	36.8	36.6	36.5	36.2	36.0	35.6	35.2	34.6	34.0	33.2	32.2		
3.61	37.9		37.6	37.5	37.4	37.3	37.3	37.2	37.0	36.9	36.7	36.5	36.2	35.9	35.5	34.9	34.3	33.5	32.6		
3.62	38.2		37.8	37.8	37.7	37.6	37.5	37.4	37.3	37.2	37.0	36.8	36.5	36.2	35.8	35.2	34.6	33.9	32.9		
3.63	38.4		38.1	38.0	37.9	37.8	37.8	37.7	37.6	37.4	37.2	37.0	36.8	36.5	36.1	35.6	34.9	34.2	33.3	32.2	
3.64	38.7		38.3	38.3	38.2	38.1	38.0	37.9	37.8	37.7	37.5	37.3	37.1	36.7	36.3	35.9	35.3	34.5	33.6	32.6	
3.65	38.9		38.6	38.5	38.4	38.4	38.3	38.2	38.1	37.9	37.8	37.6	37.3	37.0	36.6	36.2	35.6	34.9	34.0	33.0	
3.66	39.2			38.8	38.7	38.6	38.5	38.4	38.3	38.2	38.0	37.8	37.6	37.3	36.9	36.5	35.9	35.2	34.3	33.4	
3.67	39.4			39.0	38.9	38.9	38.8	38.7	38.6	38.5	38.3	38.1	37.9	37.6	37.2	36.8	36.2	35.5	34.7	33.7	
3.68	39.6			39.3	39.2	39.1	39.0	38.9	38.8	38.7	38.6	38.4	38.2	37.9	37.5	37.1	36.5	35.8	35.0	34.1	
3.69	39.9			39.5	39.5	39.4	39.3	39.2	39.1	39.0	38.8	38.7	38.4	38.2	37.8	37.4	36.8	36.2	35.4	34.4	33.3

H1 (FT)	Free Flow (CFS)	Submerged flow (CFS): H4(FT)																			
		2.59	2.63	2.67	2.71	2.76	2.80	2.85	2.89	2.94	2.99	3.05	3.10	3.16	3.22	3.28	3.34	3.40	3.47	3.53	3.60
3.70	40.1	39.8	39.7	39.7	39.6	39.5	39.4	39.3	39.2	39.0	38.8	38.6	38.3	37.9	37.5	36.9	36.2	35.4	34.4		
3.71	40.4		40.0	39.9	39.8	39.8	39.7	39.6	39.4	39.3	39.1	38.9	38.6	38.2	37.8	37.2	36.5	35.7	34.7		
3.72	40.6		40.3	40.2	40.1	40.0	39.9	39.8	39.7	39.5	39.4	39.1	38.9	38.5	38.1	37.5	36.9	36.1	35.1		
3.73	40.9		40.5	40.4	40.4	40.3	40.2	40.1	40.0	39.8	39.6	39.4	39.1	38.8	38.4	37.8	37.2	36.4	35.5	34.3	
3.74	41.1		40.8	40.7	40.6	40.5	40.4	40.3	40.2	40.1	39.9	39.7	39.4	39.1	38.7	38.2	37.5	36.7	35.8	34.7	
3.75	41.4		41.1	41.0	40.9	40.8	40.7	40.6	40.5	40.4	40.2	40.0	39.7	39.4	39.0	38.5	37.8	37.1	36.2	35.1	
3.76	41.6			41.2	41.2	41.1	41.0	40.9	40.8	40.6	40.5	40.3	40.0	39.7	39.3	38.8	38.2	37.4	36.5	35.5	
3.77	41.9			41.5	41.4	41.3	41.2	41.1	41.0	40.9	40.7	40.5	40.3	40.0	39.6	39.1	38.5	37.8	36.9	35.9	
3.78	42.2			41.8	41.7	41.6	41.5	41.4	41.3	41.2	41.0	40.8	40.6	40.3	39.9	39.4	38.8	38.1	37.3	36.2	
3.79	42.4			42.0	42.0	41.9	41.8	41.7	41.6	41.4	41.3	41.1	40.9	40.6	40.2	39.7	39.1	38.5	37.6	36.6	35.4

H1 (FT)	Free Flow (CFS)	Submerged flow (CFS): H4(FT)																			
		2.66	2.70	2.74	2.79	2.83	2.88	2.92	2.97	3.02	3.07	3.13	3.18	3.24	3.30	3.36	3.43	3.49	3.56	3.63	3.69
3.80	42.7	42.3	42.2	42.2	42.1	42.0	41.9	41.8	41.6	41.5	41.3	41.0	40.7	40.3	39.8	39.2	38.5	37.6	36.6		
3.81	42.9		42.5	42.4	42.3	42.2	42.1	42.0	41.9	41.7	41.5	41.3	41.0	40.6	40.1	39.6	38.8	38.0	36.9		
3.82	43.2		42.8	42.7	42.6	42.5	42.4	42.3	42.2	42.0	41.8	41.6	41.3	40.9	40.5	39.9	39.2	38.3	37.3	36.1	
3.83	43.4		43.1	43.0	42.9	42.8	42.7	42.6	42.5	42.3	42.1	41.9	41.6	41.2	40.8	40.2	39.5	38.7	37.7	36.5	
3.84	43.7		43.3	43.2	43.2	43.1	43.0	42.9	42.7	42.6	42.4	42.2	41.9	41.5	41.1	40.5	39.9	39.0	38.1	36.9	
3.85	44.0		43.6	43.5	43.4	43.3	43.2	43.1	43.0	42.9	42.7	42.5	42.2	41.8	41.4	40.9	40.2	39.4	38.4	37.3	
3.86	44.2			43.8	43.7	43.6	43.5	43.4	43.3	43.1	43.0	42.7	42.5	42.1	41.7	41.2	40.5	39.8	38.8	37.7	
3.87	44.5			44.1	44.0	43.9	43.8	43.7	43.6	43.4	43.3	43.0	42.8	42.4	42.0	41.5	40.9	40.1	39.2	38.1	
3.88	44.8			44.3	44.3	44.2	44.1	44.0	43.8	43.7	43.5	43.3	43.1	42.7	42.3	41.8	41.2	40.5	39.6	38.5	
3.89	45.0			44.6	44.5	44.4	44.3	44.2	44.1	44.0	43.8	43.6	43.4	43.1	42.7	42.2	41.6	40.8	39.9	38.9	37.6

CAST-IN-PLACE CONCRETE TRAPEZOIDAL FLUMES

Table 2.—Free- and submerged-flow discharge (cubic feet per second) with water depths h_1 and h_2 measured on 1.25:1 sidewall with sloping gage for trapezoidal flume No. 2 (2-ft bottom approach width, 1-ft bottom throat width, and 1.25:1 sidewall)—Continued

H1 (FT)	Free Flow (CFS)	Submerged flow (CFS): H4(FT)																			
		2.73	2.77	2.81	2.86	2.90	2.95	3.00	3.05	3.10	3.15	3.21	3.27	3.33	3.39	3.45	3.52	3.58	3.65	3.72	3.79
3.90	45.3	44.9	44.8	44.7	44.7	44.6	44.5	44.3	44.2	44.0	43.8	43.5	43.2	42.8	42.3	41.7	40.9	39.9	38.8		
3.91	45.6		45.1	45.0	44.9	44.8	44.7	44.6	44.5	44.3	44.1	43.8	43.5	43.1	42.6	42.0	41.2	40.3	39.2		
3.92	45.8		45.4	45.3	45.2	45.1	45.0	44.9	44.8	44.6	44.4	44.1	43.8	43.4	42.9	42.3	41.6	40.7	39.6	38.4	
3.93	46.1		45.7	45.6	45.5	45.4	45.3	45.2	45.0	44.9	44.7	44.4	44.1	43.7	43.3	42.7	41.9	41.1	40.0	38.8	
3.94	46.4		46.0	45.9	45.8	45.7	45.6	45.5	45.3	45.2	45.0	44.7	44.4	44.1	43.6	43.0	42.3	41.4	40.4	39.2	
3.95	46.6		46.3	46.2	46.1	46.0	45.9	45.7	45.6	45.5	45.3	45.0	44.7	44.4	43.9	43.3	42.6	41.8	40.8	39.6	
3.96	46.9			46.4	46.3	46.2	46.1	46.0	45.9	45.8	45.6	45.3	45.1	44.7	44.2	43.7	43.0	42.2	41.2	40.0	
3.97	47.2			46.7	46.6	46.5	46.4	46.3	46.2	46.0	45.9	45.6	45.4	45.0	44.6	44.0	43.4	42.5	41.6	40.4	
3.98	47.5			47.0	46.9	46.8	46.7	46.6	46.5	46.3	46.2	45.9	45.7	45.3	44.9	44.4	43.7	42.9	41.9	40.8	
3.99	47.7			47.3	47.2	47.1	47.0	46.9	46.8	46.6	46.5	46.2	46.0	45.6	45.2	44.7	44.1	43.3	42.3	41.2	39.9

H1 (FT)	Free Flow (CFS)	Submerged flow (CFS): H4(FT)																			
		2.80	2.84	2.89	2.93	2.98	3.03	3.08	3.13	3.18	3.23	3.29	3.35	3.41	3.47	3.54	3.61	3.67	3.74	3.81	3.88
4.00	48.0	47.6	47.5	47.4	47.3	47.2	47.1	47.0	46.8	46.7	46.4	46.2	45.8	45.4	44.8	44.2	43.4	42.4	41.2		
4.01	48.3		47.8	47.7	47.6	47.5	47.4	47.3	47.1	47.0	46.7	46.5	46.1	45.7	45.2	44.5	43.7	42.8	41.6		
4.02	48.6		48.1	48.0	47.9	47.8	47.7	47.6	47.4	47.3	47.0	46.8	46.4	46.0	45.5	44.9	44.1	43.1	42.0	40.7	
4.03	48.8		48.4	48.3	48.2	48.1	48.0	47.9	47.7	47.6	47.3	47.1	46.8	46.4	45.8	45.2	44.5	43.5	42.4	41.1	
4.04	49.1		48.7	48.6	48.5	48.4	48.3	48.2	48.0	47.9	47.7	47.4	47.1	46.7	46.2	45.6	44.8	43.9	42.8	41.5	
4.05	49.4		49.0	48.9	48.8	48.7	48.6	48.5	48.3	48.2	48.0	47.7	47.4	47.0	46.5	45.9	45.2	44.3	43.2	41.9	
4.06	49.7		49.3	49.2	49.1	49.0	48.9	48.8	48.6	48.5	48.3	48.0	47.7	47.3	46.9	46.3	45.5	44.7	43.6	42.4	
4.07	50.0			49.5	49.4	49.3	49.2	49.1	48.9	48.8	48.6	48.3	48.0	47.7	47.2	46.6	45.9	45.0	44.0	42.8	
4.08	50.2			49.8	49.7	49.6	49.5	49.4	49.2	49.1	48.9	48.6	48.4	48.0	47.5	47.0	46.3	45.4	44.4	43.2	
4.09	50.5			50.1	50.0	49.9	49.8	49.7	49.5	49.4	49.2	49.0	48.7	48.3	47.9	47.3	46.6	45.8	44.8	43.6	42.2

H1 (FT)	Free Flow (CFS)	Submerged flow (CFS): H4(FT)																			
		2.87	2.91	2.96	3.00	3.05	3.10	3.15	3.20	3.26	3.31	3.37	3.43	3.49	3.56	3.63	3.69	3.76	3.84	3.91	3.98
4.10	50.8	50.4	50.3	50.2	50.1	50.0	49.9	49.8	49.6	49.4	49.2	48.9	48.5	48.0	47.5	46.8	45.9	44.9	43.7		
4.11	51.1		50.6	50.5	50.4	50.3	50.2	50.1	49.9	49.7	49.5	49.2	48.8	48.4	47.8	47.1	46.3	45.3	44.1		
4.12	51.4		50.9	50.8	50.7	50.6	50.5	50.4	50.2	50.0	49.8	49.5	49.2	48.7	48.2	47.5	46.7	45.7	44.5	43.1	
4.13	51.7		51.2	51.1	51.0	50.9	50.8	50.7	50.5	50.3	50.1	49.8	49.5	49.1	48.5	47.9	47.1	46.1	44.9	43.5	
4.14	52.0		51.5	51.4	51.3	51.2	51.1	51.0	50.8	50.6	50.4	50.2	49.8	49.4	48.9	48.2	47.4	46.5	45.3	44.0	
4.15	52.3		51.8	51.7	51.6	51.5	51.4	51.3	51.1	51.0	50.7	50.5	50.1	49.7	49.2	48.6	47.8	46.9	45.7	44.4	
4.16	52.6		52.1	52.0	51.9	51.8	51.7	51.6	51.4	51.3	51.1	50.8	50.5	50.1	49.6	49.0	48.2	47.3	46.1	44.8	
4.17	52.8			52.3	52.2	52.1	52.0	51.9	51.7	51.6	51.4	51.1	50.8	50.4	49.9	49.3	48.6	47.7	46.6	45.3	
4.18	53.1			52.7	52.5	52.4	52.3	52.2	52.1	51.9	51.7	51.4	51.1	50.8	50.3	49.7	48.9	48.0	47.0	45.7	
4.19	53.4			53.0	52.8	52.7	52.6	52.5	52.4	52.2	52.0	51.8	51.5	51.1	50.6	50.0	49.3	48.4	47.4	46.1	44.7

END

