



**AgEcon** SEARCH

RESEARCH IN AGRICULTURAL & APPLIED ECONOMICS

*The World's Largest Open Access Agricultural & Applied Economics Digital Library*

**This document is discoverable and free to researchers across the globe due to the work of AgEcon Search.**

**Help ensure our sustainability.**

Give to AgEcon Search

AgEcon Search

<http://ageconsearch.umn.edu>

[aesearch@umn.edu](mailto:aesearch@umn.edu)

*Papers downloaded from **AgEcon Search** may be used for non-commercial purposes and personal study only. No other use, including posting to another Internet site, is permitted without permission from the copyright owner (not AgEcon Search), or as allowed under the provisions of Fair Use, U.S. Copyright Act, Title 17 U.S.C.*

*No endorsement of AgEcon Search or its fundraising activities by the author(s) of the following work or their employer(s) is intended or implied.*

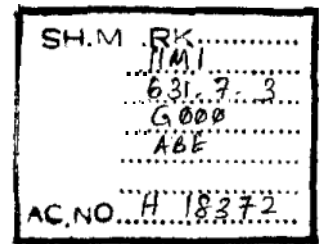

# The Institutional Framework for Irrigation

*Proceedings of a Workshop  
Chiang Mai, Thailand*



1 to 5 November, 1993

Charles L. Abemethy, editor

Sponsored by

GERMAN FOUNDATION FOR INTERNATIONAL DEVELOPMENT

INTERNATIONAL IRRIGATION MANAGEMENT INSTITUTE

ROYAL IRRIGATION DEPARTMENT OF THAILAND

H 18372 C 3

Abernethy, C. (Ed.) 1996. The institutional framework for irrigation: Proceedings of a Workshop, Chiang Mai, Thailand, 1-5 November 1993. Colombo, Sri Lanka. International Irrigation Management Institute. vi, 128p.

*/irrigation management / irrigated farming / water management / water law / legislation / soil management / farmer participation / institutional building / Southeast Asia / South Asia / South America / Australia / Indonesia / Lao PDR / Malaysia / Philippines / Thailand / Peru /*

DDC : 631.7

ISBN 92-9090-323-6

DSE Reference number  $\frac{\text{DOK 1697 A}_a}{\text{SE 770-061-93}}$

---

*Please direct inquiries and comments to:*

International Irrigation Management Institute  
P.O. Box 2075  
Colombo  
Sri Lanka

---

© IIMI, 1996

# Contents

<b>INTRODUCTION</b> . . . . .	1
<b>KEYNOTE PAPER</b> . . . . .	5
Institutional Contexts for Managing Irrigated Agriculture <i>Douglas J. Merrey</i>	7
<b>EXPERIENCES IN THE PARTICIPATING COUNTRIES</b> . . . . .	23
Indonesia . . . . .	25
Lao PDR . . . . .	26
Malaysia . . . . .	30
Philippines . . . . .	31
Thailand . . . . .	33
<b>EXPERIENCES FROM OTHER COUNTRIES</b> . . . . .	37
Institutional Framework for Irrigation: Some Salient Features of the South Asian Situation <i>D.J. Bandaragoda</i>	39
Annex 1. The Institutional Framework for Irrigation in Pakistan . . . . .	49
Annex 2. Institutional Framework for Pakistan's Irrigated Agriculture . . . . .	52
Annex 3. Some Irrigation-Related Laws in Pakistan . . . . .	53
Institutional Aspects of Irrigation in South America: The Case of Peru . . . . . <i>Klaus Urban</i>	55
Institutional and Organizational Arrangements in Australia <i>D.J. Constable</i>	63
<b>INSTITUTIONAL SERVICES</b> . . . . .	75
Service Analyses in Soil and Water Management Associations: Taking the Nienburg/Weser Association as an Example . . . . . <i>Walter Huppert and Klaus Urban</i>	77
Water Law and the Development Process . . . . . <i>D.J. Constable and B.E. Foley</i>	91
<b>REPORTS OF THE WORKING GROUPS ON MAJOR INSTITUTIONAL FACTORS</b> . . . . .	91
Working Group I: Organizations . . . . .	99
Working Group II: Governance . . . . .	100

Working Group III: Legal Framework . . . . .	101
Working Group IV: Finance . . . . .	102
Working Group V: Farmers' Roles and Status and Agency/Farmer Relationships . . . . .	103
<b>EFFECTS OF INSTITUTIONS . . . . .</b>	<b>105</b>
Impacts of the Institutional System on the Participants and on Irrigation Performance . . . . .	107
C. M. Wijyaratna	
<b>COUNTRY VISIONS OF FUTURE INSTITUTIONAL DEVELOPMENT . . . . .</b>	<b>115</b>
Indonesia . . . . .	117
Lao PDR . . . . .	118
Malaysia . . . . .	119
Philippines . . . . .	120
Thailand . . . . .	120
<b>SYNTHESIS . . . . .</b>	<b>123</b>
Regional Features of Institutional Evolution in Southeast Asia . . . . .	125
Charles L. Abernethy	

## **INTRODUCTION**

# Introduction

Charles L. Abernethy<sup>1</sup>

FROM 1990 TO 1994, the German Foundation for International Development (DSE) conducted a program of "Dialogue and Training for Irrigation Management" with four countries of Southeast Asia: Indonesia, Malaysia, the Philippines and Thailand. DSE obtained sponsorship and financial support for this program from the Government of Germany, through its Federal Ministry of Co-operation (BMZ) and invited the International Irrigation Management Institute (IIMI) to collaborate in implementing the activities of the Program.

A key event in that sequence of workshops and seminars was a meeting at Langkawi, Malaysia, of senior officials, from many departments concerned with irrigated agriculture and its consequences. This meeting, in October 1992, discussed long-range ideas about the future. Its proceedings were published by DSE and IIMI under the title "Irrigated Agriculture in Southeast Asia beyond 2000."

A common theme at that meeting was the question of institutions. Leaders of the irrigated agriculture sector throughout the region expressed concerns about the appropriateness or relevance of existing institutions, and about their capacity to evolve and change in order to confront the numerous categories of new problems which were generated (in many cases) by the economic successes of the region, and the resulting stresses on human resources, investment decisions, rights to and conservation of natural resources, and many other areas.

The Southeast Asian irrigation community also sought information about the institutional experiences of other regions and countries, particularly in regard to privatization and other forms of governmental disengagement from irrigation management. Traditionally, in this region, governments had played a dominant role in irrigation development, operation and finance, but they were under many pressures to change these institutional formats. How might this affect the performance of irrigated agriculture, and the welfare of **all** its participants?

In response to these expressed concerns, DSE and IIMI joined with the Royal Irrigation Department of Thailand to promote a further workshop on these matters. This volume is the result. The workshop was held at Chiang Mai, Thailand, in November 1993. In addition to the four countries of the main program, on this occasion a team from the Lao People's Democratic Republic were also invited, and participated actively.

The participants were asked, before the meeting, to arrange discussion materials under five subject areas, which were:

- Organizations and their allocated functions
- Governance
- Legal framework
- Finance
- Farmers' roles, and agency/farmer relationships

In the conduct of the workshop sessions, discussions were also structured according to this format.

---

1 Senior Technical Advisor of the International Irrigation Management Institute, Colombo, Sri Lanka.

The meeting proceeded by defining existing institutional arrangements in each country; discussing each of the subject areas and their possible impacts on performance; and developing country-level visions for appropriate future institutional frameworks.

Many thanks are due: to the Royal Irrigation Department for the workshop arrangements; to the resource persons who brought in practical experiences from Australia, South Asia, Peru and Germany; to the teams from the five countries who generated lively debates; to IIMI staff who brought a global range of views on the young but vigorous field of irrigation management research; and to the session moderators and facilitators who encouraged the various working groups to develop and expand their ideas.

Most of all, credit must be given to DSE and its energetic program leader Mr. Franz Heim, who has been the motivating force behind this innovative five-year series of discussions and debates, focusing attention on matters of high economic significance.

Irrigated agriculture remains one of the largest economic sectors, in this region of very high economic growth rates. Other, newer sectors may seem more glamorous; but the quest for optimal arrangements that will secure high performance from irrigated agriculture, while at the same time providing satisfaction and security to all its stakeholders, is vital for the underpinning of the region's overall success.

**As** young labor forces are attracted away from agriculture towards other sectors of these dynamic economies, the need for efficient management and high productivity will continue to grow. These five countries, with 6 percent of the world's population and 4.5 percent of its irrigated land, produce 15 percent of its rice. But their agricultural populations started to decline in the last five years, and this change is likely to persist and intensify. The importance of modernizing its irrigation institutions, and helping them to deal successfully with these new challenges, is very clear.



**KEYNOTE PAPER**

# Institutional Contexts for Managing Irrigated Agriculture

Douglas J. Merrey<sup>2</sup>

*The fact that the problem of designing incentive-compatible institutions— institutions capable of achieving compatibility between individual, organizational, and social objectives— has not been solved at even the most abstract theoretical level means that institutional design proceeds on an ad hoc trial-and-error basis— and that the errors continue to be expensive. (Ruttan 1993)*

## INTRODUCTION

THE PURPOSE OF this paper is to provide a framework for the work of this workshop. In order to do this, the paper addresses four questions. These questions are:

- a. What do we mean by the terms "institution" and "organization"?
- b. Why are institutions and organizations important?
- c. What are some of the key issues and problem areas, given the range of variation in institutional arrangements for management of irrigated agriculture?
- d. What will be the ingredients for a successful institutional framework for irrigation in the future and how can policymakers facilitate the necessary institutional changes?

The hope is that the discussion of these four questions will provide a useful guide as we are introduced to the experiences from other countries, as we try to grapple with what we think future institutional arrangements will—or should— look like, and discuss what the possibilities are for reform and improvement in the future. The paper is necessarily conceptual; other papers will introduce specific cases and examples as the workshop proceeds. It is also selective: the topic is vast, so I have deliberately chosen issues I believe are particularly important.

This workshop is particularly timely. Many of you would have heard that the Nobel Prize for Economics for this year was recently announced. For the first time the prize did not go to classical economic theorists or econometricians, but to two economic historians, Robert Fogel and Douglas North.

Classical economic theory has a tendency to depend on "pure" market analysis; that is, to assume for the purpose of analysis that something like a free market operates, in which individuals act according to rational calculations of material self-interest based on near-perfect knowledge. Of course economists know that none of this is true in reality, but it is a convenient fiction for

---

<sup>2</sup> Program Leader, Sector-Level Management of Irrigated Agriculture and Improving Public Irrigation Organizations Programs, IIMI.

analytical purposes. Things like "institutions," culture, politics, etc., are "noise" that interferes with otherwise elegant analyses.

Fogel and particularly North legitimized for economists the study of historical processes and the role of social institutions in economic growth, thus building an important bridge between economics and other social sciences such as sociology, political science, and anthropology. From economists' perspective, of course, we sociologists and anthropologists are students of that "noise" that upsets their calculations, and is inherently chaotic and not amenable to scientific analysis.

"Institutional economics" is to a considerable degree the creation of these two economists, along with others. Their central insight is that people's responses to economic incentives are to a very large degree a function of the institutional framework within which they live. How people respond to economic incentives, and their consequences for a society are largely a function of institutions such as property rights, laws of contract, functioning regulatory organizations and the like. An appropriate, effective institutional framework is a necessary condition for long-term sustainable economic growth and therefore for a sustainable productive irrigated agriculture sector.

## WHAT DO WE MEAN BY THE TERMS "INSTITUTION" AND "ORGANIZATION"?

The terms "institution" and "organization" are often used loosely and interchangeably. Indeed they are overlapping terms, but it is helpful to distinguish between them, as many social scientists do. "Organizations" are *structures of recognized and accepted roles*" (Uphoff 1986). Thus, a simple voluntary society with a president, secretary, and members is an "organization." It has roles — president, secretary, and member — who have specific functions, and specific relationships among them. Examples of "organizations" include: an irrigation department; a water users association; a cooperative; a voluntary organization (NGO); the German Foundation for International Development and IIMI.

The term "institution" has a different definition: institutions are *complexes of norms and behaviors that persist over time because they are valued as well as useful*. Note the key characteristics — they are patterns of norms and behaviors which persist because they are valued and useful. There are thus institutions which are not organizations: the laws of a country are institutions *in themselves* which exist separately from the particular courts which enforce them. Unwritten customary rules for sharing water in an indigenous irrigation system may be an institution if it is valued and persists over time in a community — regardless of whether national law recognizes its legitimacy. The market — as a system to set prices through buying and selling goods — is an institution that exists separately from the particular shop or bazaar within which transactions take place. Marriage is an institution, as is kinship; they are valued principles and norms on the basis of which organizations — families, lineages — are formed.

Organizations may be "institutions" or they may not. An organization that includes a set of norms and behaviors that persists because it is valued and useful is an institution. Examples include the family, an irrigation department, a water users organization that persists over time regardless of whether it is legally recognized (though legal recognition may make it more robust — more of an institution), a private firm, DSE, or IIMI.

This means that some organizations are not necessarily "institutions." An ad hoc group that forms itself to achieve a single short-term objective, then dissolves after some time is an organization that is not an institution. When IIMI was established in 1984 it was an

organization—a structure of roles—but it was yet not an institution, as it had not persisted and developed to the point where it was perceived as valuable and useful. A water users organization formed by government officials as part of an irrigation project may be an organization which functions for the construction period; if it persists over time, and continues to fill a need that is valued and useful to its members, it becomes an institution. This is what is meant by the term "institutionalization": a process by which behaviors and roles become valued and therefore worth something, so that they continue as a part of peoples' lives.

## WHY ARE ORGANIZATIONS AND INSTITUTIONS IMPORTANT?

Both organizations and institutions are ubiquitous in human society. Humans are a social species, and therefore all societies have organizations—structured roles—and institutions—valued roles, norms and behaviors that persist. Institutions are so much a part of our lives, that we take them for granted; to a considerable extent we internalize them so that our perceptions, our concepts of right and wrong, good and bad, rational and irrational, the categories in which we think, the basic unconscious, unspoken premises in terms of which we look at and interpret the world—all these are products of our living within particular institutional landscapes. All of us have a complex set of social identities: nationality, parent, child of our parents, kinship group, language or ethnic group, discipline, policymaker, researcher or manager. These identities are all the outcome of the particular institutional framework within which we live and work. So the first part of the answer to the question on why institutions are important is that our personal identities and our mindsets—how we categorize, perceive, think, feel—are largely the result of the particular institutional and organizational context in which we live and work.

Another important function of institutions is that they provide a basis for predicting others' behavior. They provide the rules of the game, specify what we can do and cannot do, and what the consequences will be if we do not stay within the limits. Institutions like rules defining basic property rights and contracts make it possible for us to engage in transactions, for example purchasing a piece of land or a house or engaging in business. The institutional arrangements regarding property rights and contracts in the countries of the former Soviet Union obviously had a tremendous impact on what people could do or could not do and are now constraining their capacity to respond to new opportunities; developing new institutions is a complex and time-consuming but necessary process.

The fact that rights to water can be privately held in some countries, leading to water markets and sales between farmers and urban water authorities, while in other countries they are inseparable from rights to land or are owned solely by the governments, is an institutional difference with very profound consequences for management of water. Thus we see that institutions are constraints—they establish limitations and boundaries—and they provide the basis for opportunities for change, innovation or "doing business."

Finally, Organizations enable individuals to cooperate with each other, to coordinate their activities, and to mobilize resources that individuals by themselves could not obtain. It is through organizations that people get things done, and that societies grow and develop. Those organizations that are important to the longer-term welfare and functioning of society—or important to significant subsets of people—are *institutionalized*, for example, schools, police, business firms, regulatory agencies, irrigation departments, and the like. Without complex organizations and institutions modern societies by definition would not exist.

Informal organizations form and either become institutionalized or disappear in time. Further, informal social relations coexist with formal organizations and institutions. They are functionally necessary, but as the paper on South Asian institutions emphasizes (Bandaragoda

1993), when there is a gap between informal rules and behaviors and the formal institutions, serious problems can arise. In small-scale societies, cooperation and resource mobilization are no less important than in large modern nations; only the scale is different. Those societies whose institutional framework encourages and facilitates a proliferation of organizations tend to be more dynamic and innovative than those that stifle such initiative.

## **ANALYZING THE RANGE OF INSTITUTIONAL EXPERIENCES: KEY ISSUE DOMAINS**

When we read the papers about institutions in other parts of the world later in this volume, we get a glimpse of the wide range of variation in the forms and effectiveness of institutions and organizations governing irrigated agriculture. In some countries, there are also very rapid changes occurring, as governments respond to financial and other pressures by privatizing, restructuring, and the like. There is at present no research basis for definitive statements on what kinds of institutional arrangements work best, and no easy answers to the questions facing countries' irrigated agriculture or water resources sectors.

This section provides one possible framework for analyzing the range of variation, and identifies particular issues that need attention. The discussion is organized under four main headings:

- Legal framework
- Governance
- Organizations
- Finance

Clearly, these are overlapping categories, and it will not be possible to discuss each one in isolation from the others. Nevertheless, it may provide a convenient way of organizing the discussions as we look at other regions' experiences, and analyze the experiences of the countries represented in this workshop.

We should be clear that the domain we are discussing is itself very complex and wide-ranging, and not independent of other domains. The workshop is about institutional frameworks for "irrigation," the application of water to land to grow crops. On the one hand, irrigated agriculture is a sub-domain of the agriculture sector. On the other hand, irrigation is a sub-domain of the water resources sector. Countries vary considerably in how they organize these domains: some countries manage irrigation within the context of agriculture, through a ministry of agriculture for example. Some countries separate irrigation from both agriculture and the management of water resources for other purposes, through a ministry of irrigation for example. Some combine irrigation and land, separating it from water; some create "authorities" separate from line departments to do "integrated development and management of irrigated agriculture. Managing water resources for **all** purposes in an integrated way may be less common in the world, but as competition for water resources increases, this may become more common.

This paper focuses more on the institutional framework for **irrigation** management, while paying less attention to the institutions which support agriculture *per se*.

## Legal Framework

A major impediment to the economic transformation of the countries that were part of the former Soviet Union is that the existing legal framework does not clearly define basic rights and obligations vis-a-vis property, contracts, formation of companies, and the like necessary for a market-oriented economy. An effective legal framework is no less important in the irrigated agriculture sector. In many countries, we find that either some provisions of the legal framework have become constraints in achieving the goals policymakers have, or that there are gaps — areas of silence — that are constraints.

I propose to focus on three issues which have important implications for the effectiveness of a country's legal framework. These are:

- Effectiveness of laws
- Rights to water
- Environmental protection

Obviously, there are many other issues that would have to be covered in a comprehensive discussion; these include land tenure, contract law, conflict resolution, and legal provisions for forming nongovernment or private organizations.

### *Effectiveness of Laws*

Two issues are raised under this heading:

- The basic philosophy of the function of law in society
- The extent to which there is a consistency between the legal framework and observable behavior

These issues get at the broader question of the effectiveness of laws. There are other possible issues; but these two seem particularly important in understanding the potential direction of future reforms.

*Philosophy of law.* Different legal traditions start from different premises regarding the nature of law, perhaps based on deeply and subconsciously held theories of human nature. To oversimplify, I suggest two contrasting types:

- Those legal systems whose objective is primarily to limit and control undesirable behavior
- Those designed to enable and facilitate desired behavior

Most systems have elements of both, but I suggest that there are important differences in emphasis that have serious consequences for societies.

Laws which place emphasis on limiting and controlling behavior tend by and large to be very detailed: the legislation itself lays down strict details on who may do what, what may not be done, how things are to be done, etc. In other words, the legislative and regulatory functions of law are not clearly separated. An example is the water users associations' laws as adopted in most provinces of Pakistan. These laws specify many details about how a water users association is to be structured, who may be members and who may not be, and how they will transact business. Punishments for not fulfilling the provisions of the law, including not cleaning watercourses, are

also specified. Needless to say, this law has not been effective in encouraging water users associations, and is not enforceable.

The alternative approach is to design laws that specify the basic principles and objectives, in a way that then facilitates people to use the provisions to achieve their objectives. It is up to the civil service, ideally interacting with stakeholders in a transparent public process, to frame implementation regulations and procedures. Laws that make it relatively easy for water users to get themselves organized, that accept diversity in the details of organizational procedures and the like, and that provide incentives which make it worthwhile for people to form organizations are more likely to have the desired impact than the punitive type.

**Consistency of the laws and reality.** The other important issue is the extent to which legal provisions and reality are consistent with each other. In some instances, there are serious gaps: the lack of a clear legal provision covering water rights, for example, often means that people operate extra-legally, perhaps damaging the resource, or the resource **is** not developed at all. In quite a large number of cases, the legal provisions are no longer effective in influencing behavior. In the first instance, the problem may be simply one of designing and promulgating appropriate laws to fill the gap. In the second instance, the problem is far more complex. If there has been a general breakdown of "law and order" **as** indicated by widespread evasion or ignoring of the law, it may be that a government has lost some of its authority. But in many cases, it also indicates that the laws are no longer functional or appropriate: society has changed to a degree such that new laws are required that are enforceable and fit reality.

### ***Rights to Water***

This refers to the definition of who has access to water, how much they may take, what it may be used for, and what are users' responsibilities regarding the quality of water returned to the source. Who pays what to whom for water may **also** be an important issue. I suggest three characteristics of water rights are particularly important for our purposes:

- Clarity
- Security
- Transferability

In principle there are four categories of ways to allocate rights to water:

- a. No clear legal provisions regarding rights
- b. Government ownership and control through administrative mechanisms
- c. Users' ownership and control through recognized organizations
- d. Market mechanisms for allocation and transfer of access and use rights

Throughout the world, there **is** a wide variation in provisions regarding water rights, and few "pure" cases fitting under one of the above categories. Although there may be a few countries with no legal provisions at all regarding access to and use of water, we do find countries where the law **is** ambiguous and unclear, leading to conflicts. A complete lack of legal provisions may be acceptable when there **is** a large surplus of water, but **as** competition increases this will lead to depletion in terms of both quantity and quality, and to severe conflicts and imbalances.

In many countries, water is allocated administratively, by the government: the government claims ownership of water, and makes it available to a variety of **users** for particular defined purposes through administrative processes. In such a system, there is a danger of rent seeking and inefficient use of water, especially when allocation among uses is restricted.

In a growing number of countries, administrative allocation is being modified by increasing the role of user groups in decisions regarding water allocation and use. Finally, there is increasing interest among some policymakers, donors, and economists on the potential for improving long-term water management through market incentives, based on private rights to water. Examples of this can be cited from the **USA**, groundwater systems in India, and elsewhere.

In a system dominated by administrative allocation of water, rights to use water may be clear, and may be secure; but only the government can effect transfers of rights of access and use. In a system where users share control with the government, security of rights may be achieved, but clarity may be sacrificed if rights are shared by users and the government; transferability is also likely to be limited within a particular use (say, irrigation) and within a particular basin if not an irrigation system. It is only in a system governed by market mechanisms, in which individuals or groups or both have clear and secure title to specific measurable quantities of water that full transferability is achievable.

Until recently, no one thought of market mechanisms as appropriate for governing the use and transfer of water. It is still only a theoretical concept in many countries. But it is increasingly common in some of the developed countries (California being a well-known but not unique example), and is found in some developing countries, for example Chile (Gazmuri 1992). It is claimed that making rights to water clear, secure and entirely transferable and tradable has led to dramatic improvements in efficiency and productivity of water in Chile, and has reduced the necessity for public investment in new infrastructure. In India and other South Asian countries, sophisticated markets in groundwater have developed in some irrigated areas, sometimes parallel to administrative allocation on public canal systems. There is evidence that these markets promote more equity, not **less** as may be thought, and more efficient and productive use of water; Chambers et al. (1989) have suggested that allocating clear and secure rights to water (and trees) to poor communities would be an effective means to reduce poverty in India.

During the last few decades, irrigation systems were being developed with little regard to the potential for competing demands on water: it was assumed that the water resources were sufficient to meet all the demands. Now even the countries of Southeast Asia, which from a global perspective are not water-deficient countries, are facing serious conflicts and shortages in at least some river basins. Pressures will build for countries to consider market mechanisms for improving water use efficiency; in such a case, the role of governments will shift from control and allocation through administrative mechanisms to regulating and refereeing the process. This is because at present irrigation uses by far the largest amount of water but gives the lowest economic return per unit of water.

The continuing provision of subsidized water to irrigation, while poor people in large cities pay large amounts for low-quality domestic water, is not sustainable (Bhatia and Falkenmark 1992). There is no doubt that in many countries water will be transferred from agriculture to other uses; but **how** this is to be managed remains a big question.

### ***Environmental Protection***

This too is a broad area, but its importance is increasingly recognized. I suggest two inter-related issues:

- The extent to which irrigated agriculture is threatened by the behavior of people upstream of irrigation systems or by irrigators' own behavior
- The extent to which irrigation behavior is a threat to others outside the irrigation system



The former relates to protection of watersheds, **and** the soils and aquifers that are part of the irrigation system, The latter relates primarily to the impact of drainage water whose quality is affected by its use for irrigation, and also to the depletion of aquifers shared with other users. The real issue is, how can laws contribute to protecting the environment?

This question cannot be addressed separately from the questions of philosophy of law, and water rights. From a legal perspective, the choices are the same as the four categories of water rights mentioned above. Lack of legal provision for protecting the quality of water, watersheds, and aquifers is increasingly dangerous in most countries. Attempting to control these matters through government administrative mechanisms—restricting access, licensing, etc.— is the traditional approach, but is difficult to implement, and often leads to what economists politely refer to as "rent seeking" and "externalities."

Shared control with users may be better but by itself does not provide a clear signal for evaluating the costs and benefits of the tradeoffs involved. There is an interesting example of full local control from California for aquifer management. In California, the government's policy is to encourage and support the development of autonomous local institutions which take responsibility for aquifer management: a recent study has shown that while there is considerable variation among river basins in the types of organizations that have emerged and their effectiveness, in most basins aquifers are now managed in ways that appear sustainable (Blomquist 1992).

A key factor of course is the use of market mechanisms for valuing and charging for water. If water is a valuable asset, to which local groups or individuals have clear, secure and transferable rights, they have considerable motivation to ensure that aquifers are preserved. The same principle applies to water quality: if water **is** a tradable good, and if one's use of the water affects its value to others further downstream, one approach **is** to require upstream users to pay the costs incurred for purification.

## Governance

Governance refers to the basic allocation of power and authority, and the boundaries and limits on authority. In federal systems, water is often a responsibility of provinces or states, with the central government attempting to provide overall guidelines, and mediating interstate sharing of water resources. But even federal systems may have highly centralized concentration of authority over water.

I suggest three basic forms of governance:

- Centralized— authority is concentrated in the government bureaucracy
- Decentralized— authority is shared between the higher and lower levels of the bureaucracy
- Devolved— authority is devolved to local organizations

Actual systems may **not** fit these categories entirely, but exhibit elements of two or even all three of these forms. But the type of governance characteristic in a given country will have a very significant impact on performance, and on what types of future policies may be feasible.

### *Centralized Authority over Water*

In a centralized system, authority over water allocation is concentrated at relatively high levels of government bureaucracies. The government not only makes policy; it **also** takes the primary responsibility for implementing water allocations and deliveries. It controls—or attempts to

control—water allocations among and within sectors; it may manage water distribution directly, or may regulate the use of water through issuing permits or licenses. Such systems are generally characterized by administrative allocation of water, discussed above.

### ***Decentralized Authority over Water***

In a decentralized system, the government retains authority and control over water, but the locus of control is at lower levels of the bureaucracy, closer to the users. In such a system, there may be a clearer separation of the policymaking and implementation functions, with policymaking retained at higher levels, while implementation within the policy guidelines is at lower levels. This form of governance makes sharing control over water with user groups more feasible and more likely. But administrative control of water allocation and distribution is still likely to be the dominant mode of management, supplemented with the issuing of permits to local users.

### ***Devolved (Local) Authority over Water***

This type of governance involves local governments, local boards, and local nongovernment organizations such as utilities, user groups, firms, and individuals having primary control over the allocation, distribution, and decisions about the use of water. In this type of system, policymaking and implementation are clearly differentiated: the higher-level government's role is to set broad policy frameworks, regulate the use of water to avoid abuses or imbalances, and perhaps, provide specialized support services not available in the private sector. In such a system, allocation is most likely to be governed by market mechanisms, though a system of permits issued by local authorities is also possible.

"Turnover" and "privatization" are important issues relative to establishing a devolved or localized system for governance. Turnover generally involves giving authority for management of water and delivery infrastructure to local users, but often the government retains ownership and ultimate (residual) control. It is not clear to what extent such a policy is conducive to local investment in operation, maintenance and especially long-term improvement,

Privatization is the most common term for the policy of turning over full ownership of infrastructure, as well as clear rights to specific amounts of water. In principle, if local users own the assets and have clear, secure and transferable rights to water, they are more likely to use the water efficiently (especially when there are other potential users willing to pay more for it) and more likely to invest in infrastructural improvements.

## **Organizations**

Following directly from the broad forms of governance, is the question of what types of organizations are found in the irrigated agriculture sector, and what are the implications of the presence of particular kinds of organizations for future developments. The analysis here distinguishes the policy and implementation levels; and within each, identifies a variety of arrangements.

### ***Organization at the Policy Level***

At this level, there are three primary types of organization:

- Specialized ministry of irrigation, separate from ministries handling agriculture and other water resource uses

- Ministry of agriculture that includes responsibility for irrigation, but not other uses of water
  - Ministry of water resources that includes irrigation as well as other uses of water, separate from the ministry of agriculture

**Specialized ministry of irrigation.** Some countries have regarded irrigation as so important to their development, and as sufficiently distinctive in the policies and management required, that they have established ministries specialized in irrigation. A common subtype is those countries where irrigation is a wing of a public works ministry, or as in Sri Lanka, a wing of a land development ministry. In these cases, one usually finds a heavy emphasis on relatively large-scale irrigation, and a strong construction-orientation. Problems of coordination with the ministry of agriculture, representing the main clients of the irrigation managers, is a frequent characteristic. I suggest the hypothesis that once a country reaches a situation where there is competition between irrigation and other uses of water, this mode of organizing at the policy level is likely to prove increasingly ineffective.

**Ministry of agriculture that includes irrigation.** It is not uncommon in some parts of the world to find that irrigation development and management are within a ministry of agriculture at the policy level. This mode of organization increases the likelihood of close integration and coordination of irrigation and other agricultural functions; I suggest the hypothesis that this mode of organizing is more conducive to a stronger management approach to irrigation, with less emphasis on heavy construction.

On the other hand, as competition for water with other users increases, irrigation may continue to dominate beyond a point where it is economically viable. In Israel for example, all water allocations are done from within the ministry of agriculture; although Israel is justly famous for its relatively high irrigation efficiencies, this arrangement may have led Israel into more dependence on irrigated agriculture than is sustainable in the long term (Sexton 1990).

**Ministry of water resources that includes irrigation.** A third major alternative for organizing irrigation policymaking is to include irrigation in a ministry of water resources, separate from the ministry of agriculture. A subtype would be a ministry of natural resources including water. This approach has the advantage of allowing an integrated and comprehensive approach to the water sector, which is increasingly important in countries facing serious shortages and competition among different water uses. It begs the question of coordination with agriculture, which in most developing countries is still the most important economic sector in terms of employment if not income generation.

It is also possible to combine some of the above types. For example, Egypt has a Ministry of Public Works and Water Resources, within which the Irrigation Department is a powerful management agency. The danger in this approach is that "public works"—construction—may be given too great an emphasis vis-a-vis management of the water supply.

### ***Organization at the Implementation Level***

Organization for managing implementation may be congruent with the policy management arrangements described above, or may not. At the implementation level, I suggest there are four basic approaches common around the world. These are:

- Specialized irrigation civil engineering department
- Integrated authority for irrigation and agriculture

- Government-owned autonomous corporations, or utilities
- Management by local entities, with government regulation

***Specialized irrigation civil engineering department.*** This type of management organization is common in those countries having had a British colonial tradition, though it is not restricted to them. A subtype found in some countries is departments that are called water resources departments, though these are usually so specialized in irrigation that the distinction is nominal. Such departments are almost invariably highly centralized hierarchical departments whose staff are largely if not exclusive civil engineers. These departments often have a strong tradition which at least in the past ensured a high degree of loyalty and dedication. They usually have their origins as construction-oriented departments, and construction usually remains their primary interest.

As countries move from a "construction phase" in irrigation to a "management phase," there are increasingly important questions about whether such departments can make the transition to management and service orientation, and if so how they can be assisted to make this transformation. The Department of Irrigation and Drainage in Malaysia is an interesting case of a department that is changing; several states in India are presently designing major projects with donor support to hasten the transformation of their line civil engineering departments into water resources departments oriented toward management and provision of services.

***Integrated specialized authorities.*** Quite a number of countries have established special authorities on particular river basins to manage the "integrated" development and operation of water resources for multiple uses. The Tennessee Valley Authority of the USA is sometimes taken (or mistaken) as the model for these authorities; examples can be cited from Malaysia, India, Sri Lanka and other places. A variation on this type is the creation of authorities that operate parallel to irrigation departments, but at the tertiary level, to support tertiary irrigation development and farmer involvement. India's Command Area Development Authority (CADA) is a well-known example.

But the classic authorities are created by special legislation, and have special powers and authority for constructing the infrastructure to harness the water resources of a river basin, developing the "downstream" irrigation facilities, settling people or assisting in their reorganization for agricultural production, and providing integrated support services for agriculture, and sometimes other services.

These authorities often have a degree of flexibility, legal authority, and attractive incentives for staff that are lacking in the "normal" management organizations. They are usually effective at creating the infrastructure and getting a project up and running. But their relatively authoritarian approach, and the relatively high costs of administration, often lead to increasingly serious problems. Their authoritarianism—often combined with a high degree of idealistic paternalism—results in a relatively dependent population of clients, rather than the self-reliant autonomous farmers expected in the planning documents (Merrey 1992). Integrated management, with many services provided by and through the government, is also expensive; as governments come under increasing financial pressures, the viability of continuing integrated authorities becomes an important issue.

***Autonomous government-owned corporations or utilities.*** There are some cases where irrigation is managed by government-owned corporations, either nationally (Philippines) or by river basin (Morocco). There are relatively few cases of utilities, of the type found in the electricity, domestic gas, and domestic water supply sectors, though this mode of organization is frequently cited as having a high potential. Utilities, of course, may be owned by private shareholders and regulated by the government; therefore this type of organization could also appear under the next heading, in which local entities are responsible for management of irrigation.

The advantage of this mode of operation, in principle, is that corporate entities are more flexible and can adapt to changing conditions more easily than can government departments

governed by strict civil service rules. It is relatively easier to build in incentives for performance accountability of staff, and of the organization to its clients. Of course, politicians may regret their reduced opportunities for controlling access to an important resource. The success of this mode of organization is closely linked to financial autonomy, discussed below under *Finance*.

*Local control with government regulation.* Local control of irrigation through specialized irrigation companies or "districts" controlled by the user-shareholders is common in some of the developed countries, but relatively rare in developing countries outside Latin America? In this type of organization, there is a legal framework enabling local users to form organizations through which they may construct and own irrigation infrastructure and water rights. In some cases, this form of organization may coexist with a government department which does major construction, and manages large dams and canals, wholesaling water to irrigation districts (the **USA** is an example). The success of this form of management depends on the local entities having clear and secure water rights, which are preferably transferable and tradable as well. The major role of the government in this type of environment is to ensure that titles to water rights are clear, and evaluate and regulate water use to ensure sustainability and economic efficiency. The government may also provide assistance in construction of major works, manage major works, and intervene when drought or other crises make emergency measures necessary.

## Finance

Our interest for the purpose of this paper is the institutional implications of the financing of irrigation. There is no such thing as free irrigation: someone pays for it. But *who* pays, and the structuring of financial flows vary considerably among countries. These two questions have a profound impact on the institutional framework for, and the performance of, irrigation. Whether users pay directly for irrigation, based on the amount of water they use and perhaps on the quality of the water returned to the source, will have a major influence on how efficiently water is used. Whether users pay the providers of irrigation services directly or indirectly will have a major impact on the incentives for the provider to ensure that the service is responsive to the customers' needs.

### *Who Pays for Irrigation?*

I suggest three variants of "who pays," though these often coexist. They are:

- Free to users.
- Users pay part of the costs.
- Users pay full costs.

*Free to users.* It is still not uncommon that irrigation water is provided on government schemes without the users having to pay any direct fees. There are therefore no linkages among the *cost* of providing the water, the *economic value* of the water to the user or to other potential users, and the *use* of the water. It is not surprising that in such systems water is often used inefficiently, and the quality of physical maintenance and operational services is a source of constant complaint. Indirect means of recovering costs, for example taxes on produce, are often used to recover the costs of providing irrigation services, but there is no linkage between payment and the service provided.

---

3 **Shah and Bhattacharya (1992)** discuss the rise of member-companies for managing tubewells which are coming up spontaneously in Gujarat, India, and which appear to be more robust than tubewell cooperatives.

*Users pay part of the costs.* It is more frequent to find that users on public irrigation systems pay fees that cover part of the costs of the service, but not the full cost: operation and maintenance costs but not capital costs for example. But outside the richer countries of Europe and North America it is rare to find fees based on the quantity of water used, or the economic value of that water. Evasion of payment among significant numbers of users is also not uncommon, as enforcement is difficult. It is also not uncommon that the amount paid is not adequate to cover the full costs of operation and maintenance, leading to deferred maintenance, and subsidized rehabilitation.

*Users pay full costs of irrigation directly.* On publicly managed irrigation systems, it is rare to find that users are paying the full costs of providing the water (operation and maintenance as well as capital). But on private systems, for example private tubewells in South Asia, or commercial farms, users do pay the full direct costs of irrigation; and markets exist whereby owners of tubewells sell water to their neighbors. Where farmers pay the full costs, especially if other agricultural inputs are not significantly subsidized, there is a strong tendency to grow higher-value crops as lower-value grain crops may not be economical.

*Mixed systems of cost recovery.* This is probably the most common situation: in South Asia for example, "free" irrigation from public systems coexists with privately financed and owned tubewell irrigation. More commonly, while irrigated agricultural users pay nothing directly, or pay only part of the real costs of irrigation, users in other sectors pay heavily for their domestic and industrial water. In some water-short urban areas, the poorest people with the worst service pay high prices for low-quality water, while farmers and sometimes rich domestic users pay little or nothing (Bhatia and Falkenmark 1992). It is clear that as countries move towards more emphasis on market-based systems for allocating water, as a response to inter-sectoral competition in water-short areas, the present arrangements in which irrigation is subsidized at the expense of others will come under increasing pressure.

### *The Structure of Financial Flows*

No less important than the question of who pays is the question of how payment is made, i.e., how financial flows are structured. Both issues profoundly affect the incentives for providing efficient irrigation services. There are three basic alternatives:

- No one pays directly.
- Indirect financing
- Direct payments by users to provider.

If no one pays directly for water, then there is no incentive either for the user to make efficient use of the water, or for the managing agency to provide good service. This option is therefore not further discussed.

*Indirect financing of irrigation.* In many countries, for example in South Asia, if the users pay anything for irrigation services, it is not directly to the management agency, but to the government. "Irrigation fees" are collected as a kind of land tax, sometimes based on the crop grown, but rarely based on the amount of water used. This tax is collected by the revenue department of the government, and goes directly into the treasury. Funds are allocated from the treasury to the irrigation department based on criteria that have nothing whatsoever to do with the amount paid in fees. There is thus no linkage between the users' payments and the services received. Whether it provides a good or poor service has no impact on the department's income or staff incentives. This only compounds the problems arising from fees bearing no relationship to the amount of water used, or to the real costs of irrigation.

*Direct financing of irrigation.* Research has shown clearly that those irrigation agencies which are financially autonomous, to whom water users pay irrigation fees directly, show better management performance than agencies who receive their finances indirectly, such that they are dependent on the government treasury (Small and Carruthers 1991; Svendsen 1992). If an irrigation agency is financially autonomous and directly dependent for a significant portion of its income on service fees paid by its customers, there will be significant incentives to provide good service.

However, it is important over the long term for that agency to have the authority to revise its fee structure as necessary, and to have the flexibility to adjust its human resources, and provide incentives for staff performance. This takes us back to a governance issue: if the autonomous agency has a monopoly, then a transparent system for monitoring and regulating its services and costs, and justifying its fees, will be necessary. In other words, the agency should operate as a public utility. An alternative is to devolve ownership and management of individual systems to corporate entities in which the users are shareholders.

## **CONCLUSION. WHAT WILL EFFECTIVE INSTITUTIONAL AND ORGANIZATION FRAMEWORKS FOR IRRIGATION LOOK LIKE IN 2025?**

### **Principles of Institutional Change**

This paper began with a discussion of the distinction between organizations and institutions, and the ways in which institutions pervade our lives and affect our thinking and understanding. Institutions develop historically through a complex process of interactions among technology, environment, and people's behavior and perceptions as shaped by their previous cultural and institutional history. Therefore, institutions in place often have considerable staying power, and seem to have a life of their own which stymie attempts at reform. Resistance to change is likely to be based on a combination of values and limited perspectives of participants, and the strong vested interests many have in existing arrangements.

One implication of this view of institutions and organizations is that they are not readily transferable from one country context to another. We cannot expect that because a particular institution works well in one place, it will automatically apply, as it is, in another. There are cases of transfer but invariably the institution is reinterpreted and transformed into something unique as part of the process. This is not to argue that we cannot learn from others' experience. On the contrary, we can, but what is transferable is the basic idea and concept, suitably transformed to fit into a new context.

The direction and rate of change, the strategies that might be most effective, and the possible options for the near and medium future are constrained by existing institutional arrangements. The trick then is to develop change strategies that are appropriate to the specific situation, and to take a long-term perspective. It is particularly important to avoid adopting solutions to short-term problems that will be nonadaptive or severely constrain future options.

Policymakers must choose between two basic change strategies:

- Radical change imposed from the top down
- Encouraging change through an iterative bottom-up long-term process

The former may be attractive when a country is facing a crisis, or a total breakdown of the existing system, as in the former Soviet Union. But it is highly risky, **is** likely to be strongly resisted, and may go wrong very easily. The latter requires more patience, but I suggest in most circumstances it is more likely to lead to the evolution of workable solutions, including new institutions. The role of the policymaker in this approach is to set the broad objectives, identify the guiding principles, and act as a coach to facilitate and guide the change process.

## Guiding Principles for the Future

Beginning from the different institutional contexts found in various countries, clearly it is not likely or desirable that there will be uniformity in the future. I would like to propose a few broad principles that could guide the evolution of institutions in the water resources and irrigated agriculture sector, principles that apply to other sectors as well. These principles are:

- Clear, secure, transferable water rights
- Decentralized and devolved management organizations
- Government role **as** facilitator and regulator, not controller
- Accountability
- Financial autonomy and sustainability

I suggest that the workshop participants might wish to consider whether they agree with these principles, whether there are others that should be added, and what the implications will be for the future development of their countries if these principles are adopted,

## References

- Bandaragoda, D. J. **1993**. Institutional framework for irrigation: Salient features of the South Asian situation. Paper prepared for DSE/IMI Workshop on "Institutional Framework for Irrigation," 1–5 November, **1993**, Chiang Mai, Thailand.
- Bhatia, R. and Falkenmark. M. **1992**. Water resource policies and the urban poor: Innovative approaches and policy imperatives. A background paper for the Working Group on "Water and Sustainable Urban Development, International Conference on Water and the Environment: Development Issues for the 21st Century," **26–31 January 1992**, Dublin, Ireland.
- Blomquist, W. A. **1992**. Dividing the waters: Governing groundwater in Southern California. San Francisco, CA: ICS Press.
- Chambers, R.; Saxena, N.C. and Shah. T. **1989**. To the hands of the poor: Water and trees. London: Intermediate Technology Publications.
- Gazmuri, R. **1992**. Chilean water policy experience. Provided as background to the presentation at the World Bank's Ninth Annual Irrigation and Drainage Seminar, December **9, 1992**.
- Merrey, D. J. **1992**. Potential for devolution of management to farmers' organizations in an hierarchical irrigation management agency: The case of the Mahaweli Authority of Sri Lanka. Presented at the Symposium on Irrigation and Society in the Context of Mahaweli. Sri Lanka, **24–29 August 1992**, Monte Verità, Ticino, Switzerland. (Forthcoming in edited volume.)



- Ruttan, V. 1993. Sustainable growth in agricultural production: Poetry, policy and science. *Interpaks DIGEST* vol. 1, No. 2, Spring 1993. (Reprinted from a paper published by the Department of Agricultural and Applied Economics, University of Minnesota. Staff Paper P 91-47, November 1991.)
- Sexton, R. 1990. Perspectives on the Middle East water crisis: Analysing water scarcity problems in Jordan and Israel. ODI-IIMI Irrigation Management Network Paper No. 90/3f. December 1990.
- Small, L. and Carruthers, I. 1991. Farmer-financed irrigation: The economics of reform. Published in association with IIMI. Cambridge: Cambridge University Press.
- Shah, T, and Bhanacharya, S. 1993. Farmer organisations for lift irrigation: Irrigation companies and tubewell cooperatives of Gujarat. ODI Irrigation Management Network Paper 26. June 1993.
- Svendsen, M. 1992. Assessing effects of policy change on Philippine irrigation performance. IFPRI Working Papers on Irrigation Performance No. 2. Washington, DC: IFPRI.
- Uphoff, N. 1986. Improving international irrigation management with farmer participation: Getting the process right. Boulder, CO: Westview Press.

## **EXPERIENCES IN THE PARTICIPATING COUNTRIES**

### **Indonesia, Lao PDR, Malaysia, the Philippines and Thailand**

*After the presentation of the keynote paper, working groups from each of the five participating countries in the Workshop were invited to review their countries' present institutional situation. The groups' reports are presented in this section.*

# INDONESIA

## Legal Framework

ACCORDING TO THE country's constitution, the state is the single owner and manager of water in the country. Private organizations or individual members of a community cannot own or manage water.

The philosophy behind the above decision is to guarantee that water can be used as much as possible for the general welfare of the nation and not for the welfare of certain groups of people or certain sectors of the country's economy. Exception, however, takes place in traditional/communal irrigation systems, where the village/community owns limited water rights, although it cannot sell its water rights.

Indonesia has a law which aims at protecting water sources from being polluted either by industry or by other water users. But the law is difficult to enforce as there is not yet a common understanding concerning the definition of water pollution, among government agencies which are to enforce the law.

There are many laws laid down by the Government of Indonesia for irrigation management in Indonesia. However, those laws are sectoral oriented and do not complement each other, and thus they are difficult to implement. Consistency of the laws thus becomes also a problem for irrigation development in the country.

## Governance

In general, in Indonesia there is centralized authority over water, although slowly the government is trying to decentralize its authority to regional governments. Farmers have no authority over water, their roles are limited to managing and maintaining the tertiary system of the government-owned irrigation system, and no authority to influence government water policy.

## Organizations

The Directorate General of Water Resources Development of the Ministry of Public Works is the single organization at policy level which manages water resources, including irrigation. The tasks of the Directorate General of Water Resources Development, among others, are (1) development and supply of irrigation water; (2) water supply for domestic consumption; (3) water supply for industry; and (4) water supply for electric power.

At the implementation level we have : the Provincial Irrigation Service which implements irrigation development projects, and maintains the main system of irrigation. To ensure effective and efficient use of irrigation in both the agriculture and the non-agriculture sectors the Government has established the so-called irrigation committee both at the provincial and district levels. At the provincial level the committee is chaired by the governor, while the district head chaired the district irrigation committee.

Semiautonomous government-owned corporations sell water to municipalities which is used to finance O&M in irrigation and also they make water allocation for domestic supply and irrigation.

At the village level we have the farmer water users association which constructs, manages, and maintains the village irrigation system but without water rights.

## Finance

Basically, water is free to users but currently the Government is moving towards requiring users to pay part of the O&M costs.

There are direct and indirect financial flows: direct financial flows in village irrigation systems where farmers pay direct costs of construction and O&M; and indirect financial flows in government irrigation systems through payment of land and property taxes and irrigation service fees as contribution towards O&M cost.

## LAO PDR

### Legal Framework

#### *Laws*

The Government of Lao PDR **is** treating legal studies as a priority activity with a view to encouraging further active community participation in the irrigation sector.

#### *Water Rights*

In general, no clear provisions exist for water rights; however traditional rights exist. On public schemes, water rights are allocated by government administration.

### Governance

Provinces in Lao PDR have been isolated due to difficulties in communication and access. **As** a result, they have been quite autonomous and authority has been fully devolved.

Now with improving access and communications, the government **has** embarked on a "vertical integration" program which will lead to some necessary control from the central level. The need for many activities and decisions to remain at the provincial and sub-provincial levels, assists with the "bottom-up" approach to government resource allocation.

### Organization

#### *Organization at Policy Level*

The Department of Irrigation is a department within the Ministry of Agriculture and Forestry.

Piped water supply (domestic water) is the responsibility of the Ministry of Construction, drinking water **is** the responsibility of the Ministry of Health and hydropower generation is the responsibility of the Ministry of Industry.

Thus, ministries are involved in the use of water resources.

### ***Organization at Implementation Level***

The Department of Irrigation, at **all** levels, is a specialized civil engineering organization. The government recognizes this **as** a constraint and studies are underway to seek recommendations for improvements.

### **Finance**

On the question of "who pays" every variant exists in Lao PDR including the "mixed system of cost recovery." Farmers may be required to pay to support operations and maintenance. Payment can take the form of cash, rice, labor or the supply of local materials. **As well as** direct financing, all landowners pay a land tax which goes to the central government and is allocated to ministries for a range of services.

Studies are underway on various aspects of the "user pays" system to find ways to make improvements. Privatization of selected irrigation schemes is also being considered.

### **Institutional Change Strategies**

Change will be encouraged through a step by step "bottom-up" approach; however, the need for some change emanating from the top is also recognized.

The government has recently adopted the following policies:

- To promote and support small-scale (family and community) irrigation projects
- To promote and encourage the participation of farmers and private sector in irrigation development
- To improve the efficiency of public resources investment and of external assistance
- To ensure economic effectiveness **as well as** environmental soundness in the development of irrigation projects

In support of these policies the Department of Irrigation will adopt the following strategies:

- To shift from direct involvement in project implementation to the promotion, support and control by regulations
- To support and promote participation of farmers and the private sector in irrigation development
- To develop and practice integrated development planning
- To decentralize and strengthen development activities at provincial, district and grass-roots levels

Organizational arrangements are shown on the attached charts. Figure 1 shows the situation at the national level and how the national level relates to the provincial and sub-provincial levels. Figure 2 shows the situation at the provincial level.

Abbreviations used in the two figures are as follows:

<b>CAB</b>	<b>Cabinet to the Ministry</b>
<b>DAFSO</b>	<b>District Agricultural and Forestry Service Office</b>

DCAE	Department of Crops and Agricultural Extension
DCAES	District Crops and Agricultural Extension Service
DFS	District Forestry Service
DHM	Department of Hydrology and Meteorology
DIS	District Irrigation Service
DLV	Department of Livestock and Veterinary Services
DLVS	District Livestock and Veterinary Service
DOF	Department of Forestry
DOI	Department of Irrigation
DOP	Department of Personnel
DSOE	District Level State-Owned Enterprise
MAF	Ministry of Agriculture and Forestry
PAFSO	Provincial Agricultural and Forestry Service Office
PCAES	Provincial Crops and Agricultural Extension Service
PFS	Provincial Forestry Service
PIS	Provincial Irrigation Service
PLVS	Provincial Livestock and Veterinarian Service
PSOE	Provincial State-Owned Enterprise
SDC	Survey and Design Centre (provincial)
SOE	State-Owned Enterprise(s)
SSDC	survey
TTIS	Thad <b>Thong</b> Irrigation School

Figure 1. Organizational linkages for irrigated agriculture in Lao PDR; National level

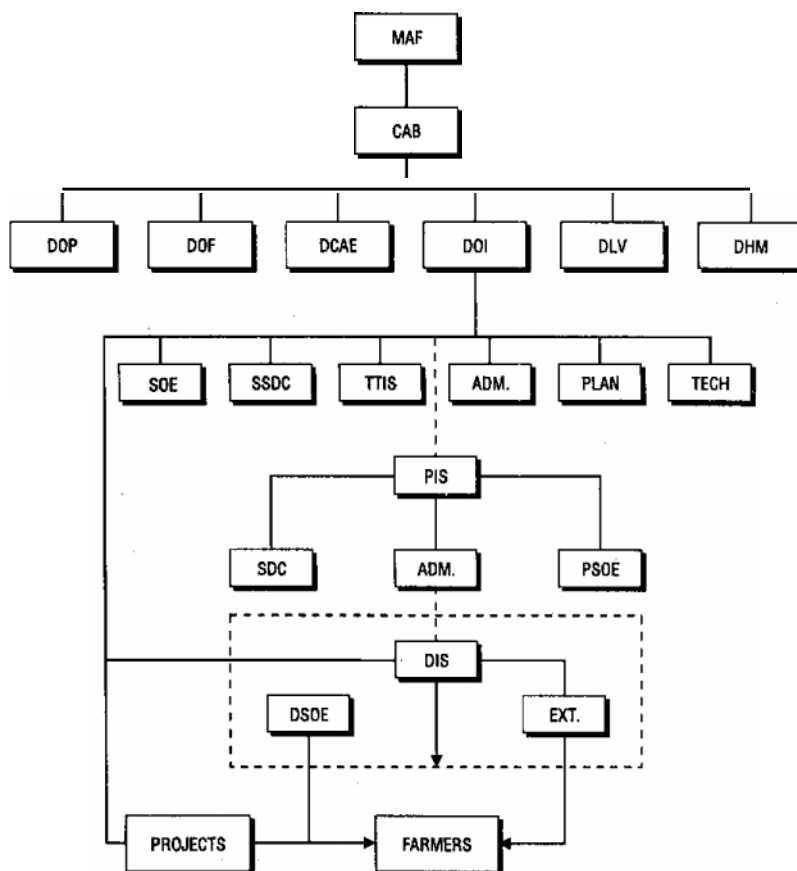
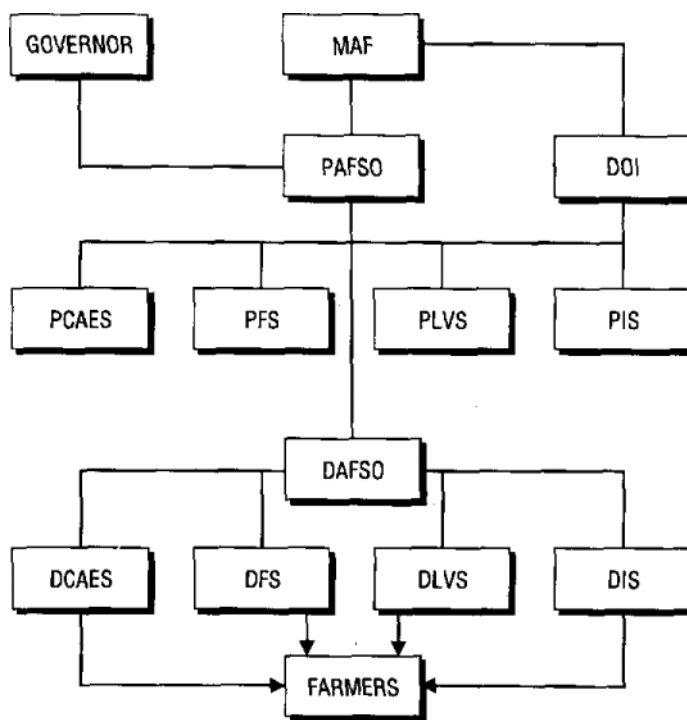

Figure 2. Organizational linkages for irrigated agriculture in Lao PDR: Provincial level.



## MALAYSIA

### Introduction

Most of the water use (about 75%) is on irrigation, which is generally government-controlled. There is a gradual transition from government control to decentralized control. Domestic and industrial consumption is about 22–24 percent. Other uses include aquaculture, hydro-electric power, navigation and recreation.

About 10 percent of agricultural land is irrigated. The main crop is rice, and there is some irrigation of horticultural crops such as fruits, flowers and vegetables.

### Water Rights

Water is owned by the State. The right to use it may be in the hands of the Federal or State Governments, or individuals through a system of water licenses.

The clarity of rights is not well defined, and security of rights depends on the granting and renewal of licenses.

Individuals cannot transfer the rights given under licenses. State governments however may sell water to other States.



## Organizations for Irrigated Agriculture

At the Federal level, the Ministry of Agriculture is responsible for policy, strategy and budgets. The Department of Irrigation and Drainage is responsible for implementation of projects and for their operation and maintenance. The Department of Agriculture is responsible for agriculture extension and training.

Other relevant organizations include :

Farmer Organization Authority (FOA) : Helps organize farmers

Ministry of Agriculture Research and Development Institute (MARDI): Conducts research.

Integrated Agriculture Development Projects (IADP): Project coordination and implementation.

Kemubu Agricultural Development Authority (KADA): Planning, implementation, operation and maintenance for a specific project area.

Muda Agricultural Development Authority (MADA): planning, implementation, operation and maintenance for a specific project area.

At the State level there is an Agriculture Committee, chaired by a senior politician, to determine State policy.

## Finance

Development costs are financed by the Federal Government, or by the States for smaller schemes.

Operation and maintenance costs are financed principally by the States.

Farmers pay water rates, in the form of a tax on the land area. These rates are not linked to the actual costs of operation and maintenance or of development, so they vary arbitrarily from State to State. For example, in Kedah the rate is 18 ringgit/acre (about US\$18.00/hectare) whereas in Negeri Sembilan it is 3 ringgit/acre (about US\$3.00/ha). The owner of land, not the tenant, pays this tax. There is no link between the amount paid and the amount used for irrigation costs.

## PHILIPPINES

### Underlying Principles of the Philippines Water Code

- All waters belong to the State.
- Utilization, exploitation, development, conservation, and protection of water resources shall be subject to the *control and regulation of the Government through the National Water Resources Council.*
- Only the State can grant *water rights (through permits).*
- Rights may be leased or transferred in whole or part *with Council approval*

## Legal Framework

### *Republic Act 3601*

The National Irrigation Administration (NIA) was created as an independent, financially autonomous entity which is empowered to charge users for its services at the level needed to recover capital costs and ensure effective systems operations.

### *Presidential Decree 552*

Allowed NIA

- To retain income from irrigation service fees and equipment rental
- To delegate to organized groups or cooperatives the partial or full responsibilities for operation and maintenance of irrigation systems
- To recover O&M and at least partial construction costs from irrigators

### *Republic Act 7607*

Magna Carta for Small Farmers

- Encourages farmers, farmworkers, as well as cooperatives and independent farmers' organizations, to participate in the planning, organization, management, and implementation of agricultural programs and projects.

### *RA 7160 - Local Government Code*

- Devolution to Local Government Units (LGUs) of locally funded communal irrigation projects

## **National Irrigation Administration (NIA) Mandate**

The mandate of NIA is to develop water resources for irrigation and provide corollary technical and institutional services in support of the agricultural development program of the national government.

## **Types of Irrigation Systems**

### *National Irrigation Systems*

NIA/LGUs initiate identification.

NIA plans and constructs with users' participation.

Joint-management during O&M between NIA and IAs (Irrigators' Associations).

### ***Communal Irrigation Systems***

Farmer - initiated.

NIA assists IAs in project packaging, fund sourcing and construction.

IA operates and maintains after turnover.

### **Financing Policies**

#### ***National Irrigation Systems***

Farmers pay for O&M cost and Irrigation Service Fee

Wet season - 2 cavans/ha/season (US\$21.00)

Dry season - 3 cavans/ha/season (US\$32.00)

Other crops - 60 percent of paddy rate

### **Communal Irrigation Systems**

At least **1.5 cavans/ha/year** (US\$16.00) for a period not exceeding 50 years

Cost to be repaid

90 percent of direct cost

*Note:* 1 cavan = 50kg of unhusked rice

### **Change Strategies**

- User-oriented framework
- Top management-initiated
- Enabling process to users organization
- Capability-building of NIA personnel and IAs

## **THAILAND**

### **Legal Framework**

- Fragmentation of laws.
- No general framework.
- Some laws no longer reflect reality
- Inadequacy of law enforcement.

## **Right to Water**

- No comprehensive water right except in certain areas under concerned agencies

## **Right to Allocate Water**

- In areas under government agencies' control, allocated by agencies
- In other areas, no clear provisions

## **Environmental Protection**

- Threats to irrigated agriculture
- Threats from irrigated agriculture to others

## **Governance**

- Mostly centralized, except in small-scale projects to serve the rural population, where some degree of decentralization exists

## **Organizations: Policy**

- Eight ministries are involved.
- Proposal to set up Ministry of Water Resources

## **Organizations: Implementation**

All four approaches exist:

- Specialized irrigation civil engineering department
- Integrated specialized authorities
- Government-owned autonomous corporations
- Management by local entities

## **Finance**

- Water for irrigation is free.
- Part of the cost, i.e., electricity is paid by farmers.

Currently, mixed systems of cost recovery are practiced: both inter-sectoral and intra-sectoral.

**Structure of Financial Flow**

- No one pays directly for irrigation
- Indirect financing by industries.

**Institutional Change Strategy**

- Radical change is that it is crisis-management oriented.

**EXPERIENCES FROM  
OTHER COUNTRIES**

# Institutional Framework for Irrigation: Some Salient Features of the South Asian Situation

D. J. Bandaragoda<sup>4</sup>

## INTRODUCTION

### Definitions

THE WORD "INSTITUTION" can be given a wider meaning than is normally understood. Defining it widely, I have used the following interpretation elsewhere:

The term "institutions" in its popular usage is usually given a restricted meaning, to refer only to "organizations" but as it is applied in this paper, the term **also** covers "rules" (laws, regulations, procedures, norms and conventions) which in fact underlie the organizations and determine the "work roles" of individuals and groups. In this sense, the term "institutions" mean both "rules" and "roles."

Organizational behavior cannot be assessed or changed without reference to its institutional environment. However, the emphasis of most evaluations and attempted remedial action **is** often on organizations or role structures, to the relative neglect of their underlying rules. The outcome is invariably not very successful. A broader definition of the term "institutions" draws attention to this neglected area of irrigation-related rules which are critically important in assessing the institutional impact on overall irrigation management performance (Bandaragoda and Firdousi 1992 chap. 2).

In this sense, the term "institutional framework for irrigation" covers the organizations, norms and practices relating to irrigation; and also the rules, procedures, and laws that underlie or govern them.

### Main Characteristics of the South Asian Situation

The institutional scene relating to irrigation in South Asia seems to be characterized by two main factors : (i) *the existence of a deep-rooted "irrigation culture;"* and (ii) *the effect of recent development initiatives on the institution building process.* Interestingly, the continuing interaction between these two factors, though not so constructive at times, is another characteristic of the South Asian situation. It is this interaction between the two influences that largely determines the quality of institutional performance.

---

4 Management Specialist of the International Irrigation Management Institute, Colombo, Sri Lanka

## SOUTH ASIAN "IRRIGATION CULTURE"

The idea that there is a distinct irrigation-related culture, which characterizes the institutional framework in South Asia, relates to the region's long history of irrigation development and practice. This culture<sup>5</sup> in my view, has tended to determine the quality and shape of institutions in this instance, and is seen to be based on the following:

- Tradition of the ruler's responsibility for social welfare, (supply-oriented administration)
- Influence of colonial administration, (regimented and formalistic)
- Dominant public sector involvement, (management by proxy through center's agents)
- Preference for legalistic/centralist administrative approach, (as against a participatory mode *of* management)

### King and the Subjects

Some of these elements are interrelated. The dominant role of the public sector in irrigation, at a glance, appears to be a product of the colonial administrative influence, but in fact, it has its roots in the interest shown **by the ancient rulers** in many aspects of irrigation development. In the region, this tradition covers **a** period of more than two thousand years.<sup>6</sup>

Although the water users played an important role in operating and maintaining the irrigation systems at that time, they were guided by the rules of the state for their required participation (this was known as *rajakariya* or "service to the king"). **Also**, regarding equitable distribution of water, there was state guidance, and the water **users** acted on the decisions of the ruler's representative in the area. The tradition of compliance in South Asia comes from over two thousand years of subordination and structured life under the Emperors, Kings, Princes, Nizams and Sultans, and the various warlords and chieftains. Compliance was not a total subservience; it was partly a reflection of the work the leaders did in using their power and resources **to** provide common goods, like irrigation, for the benefit of the people. The despotic character of these benevolent monarchies in managing these common goods is considered to have been necessitated by a social need to control large systems (Wittfogel 1957).

The fall of what is popularly referred to **as** the ancient "hydraulic civilization" in this region is attributable to the decline of this structured institutional framework for irrigation. The irrigation systems collapsed when there was no leadership or arrangement to build, maintain and operate them.

---

5 My colleague Douglas J. Merrey has explained that *culture* is a concept which can be differentiated from the concept of "social system" or "organization." He refers to *culture* as the set of values, beliefs, rules, perceptions, knowledge, etc., shared by an interacting group (Merrey 1992).

6 The history of irrigation in Sri Lanka spanning over 2,000 years refers to irrigation structures dating back to the first century BC (reign of King Kalantissa) and of such technical innovation and skill as portrayed by the Maduru Oya brick terra-cotta sluice of the same period. Irrigation was of such importance in this era, that administrative areas were identified on the basis of irrigation; the ancient district of Nuwara Kalaviya, as named, comprised the command areas of the three large tanks (reservoirs) of Nuwarawewa, Kalawewa and Padaviya.



## Colonial Period

After some centuries of neglect and decay, the abandoned infrastructure formed the basis for renewed interest in an "irrigation renaissance" during the colonial period. The largest ever reconstruction and rehabilitation program in Sri Lanka started with the renovation of its extensive network of irrigation "tanks" (reservoirs) under the British colonial administration. Following the old inundation canals, a massive canal system was built in the northern part of the subcontinent.

The vigor with which the physical system was built was matched by the enthusiasm shown in developing the needed irrigation institutions. In designing new structures and rules for the colonial administration, the British retained most of the old institutional elements found in the subcontinent. Yet, they improved substantially upon the existing supervision and compliance relationships. Understandably, the centralism in administration was strengthened. Hierarchies were established. Village leadership was formally appointed, and rules and procedures were formalized. The institutional framework for irrigation that was finally put in place in South Asia during this period was basically an innovative adaptation to suit the local conditions and values.

Despite being centralized, this institutional framework was considerably service-oriented. Many rules were aimed at providing distributive justice or equity, grievance mechanisms for dispute resolution, and accountability in operation and maintenance of the systems. There were mechanisms for the central administration to outreach for serving the people.

Until the late 1960s, the British revived old concept of *Vel Vidane* (irrigation headman) was an effective institution in Sri Lanka; to date, the *Patwar* plays a similar role in Pakistan. The present legal system for irrigation management in this region is still based on Acts promulgated by the British in the 1870s and manuals of procedure developed soon after that period (a sample from Pakistan is listed in Annex III).

I am tempted to comment that the institutional framework which the British evolved for irrigation in the subcontinent at that time can be rated as one of the best institution building attempts anywhere in the world. It served the needs of the day extremely well; in its core, it has not been fully superseded by any revision or reform to date.

## After Independence

When part of the South Asian region that was under colonial administration became independent late in the 1940s, the new nation states embarked on yet another period of concern and attention on irrigation. This was on the basis of their often expressed desire to provide food for the growing populations. To promote food production, incentives had to be built into the administration of irrigated agriculture. Support prices and subsidies paved the way for liberalization of existing rules or of their application. With increased government expenditure on irrigation development, operation and maintenance became a state responsibility. The effect of some of these development initiatives will be further discussed under Recent *Development Initiatives*.

While taking these steps towards enhanced domestic food production and accelerated social development, the new national governments that came to power jealously guarded their authority and status so that they could have close identity with these administrative measures.

Almost reflecting the colonial style, these governments preferred to maintain central authority. They liked to claim responsibility for whatever development that could be achieved. The higher the levels of government investment on irrigation development, the greater was their desire to retain irrigation management as a social responsibility. The public sector became the dominant actor in the development process; consequently, the irrigation institutional framework also became more centralized and law-enforcement oriented.

*All these traditional influences (ancient, colonial and post-colonial) combine to form the present "irrigation culture" in South Asia.* There is a natural tendency for the rural people in this region to follow these cultural footprints, even when they are in pursuit of the benefits of modern technology. Illustrating this, the irrigation officials tend to behave like feudal lords, and the farmers in their rather rare attempts at organizing themselves tend to select office bearers from elitist families. Irrespective of today's democratic ethics, big landlords in the subcontinent frequently interfere with formally laid down irrigation rules. Defying the modern day economic impulses, the farmers in Sri Lanka practice sharing both water and land during water shortage; they sacrifice their individual rights and cooperate among themselves and with officials to reduce their risks during drought (this practice is called *bethma*).

## RECENT DEVELOPMENT INITIATIVES

The effect of recent development initiatives on the present institutions for irrigation in South Asia can be seen in the following issues :

- Overlapping agency responsibilities,
- Emphasis on technical processes,
- "Soft state" effect on application of rules,
- Excessive political intervention,
- Popular notion of "good officials and bad farmers," and
- Recent attempts at institutional change.

### Proliferation of Organizations

South Asia can be described as a region which has attempted fast development in political processes. Immediately after independence, and in some cases even before independence, the countries were quick to adopt the Westminster mode of democratic institutions. India, Pakistan and Sri Lanka embarked on parliamentary democracy, almost together, immediately with the declaration of independence. Universal franchise was introduced to Sri Lanka as early as in 1932.

In sum, political development in this region has proceeded ahead of economic development. As a result, there has been a proliferation of political and administrative organizational structures (ministries, departments, divisions, bureaus, corporations, centers, institutes, etc.) beyond the economic needs of these countries. For political reasons, a large number of elected members have to be given ministerial positions, and the result is adilution of functions into numerous portfolios. Each ministry then has a tendency to build its own administrative empires. The irrigated agriculture sector, because of its social and economic importance, attracted more than its due share from this institutional extravaganza.

Thus, the presence of too many agencies with diffused or overlapping responsibilities is the result of a rapid political modernization process and the associated development strategies which were based on sectoral (and even sectarian) policies. This is a feature common to most of the countries in the region. Sri Lanka has been described as having more "irrigation institutions per hectare" than most countries. India and Pakistan, being relatively large countries with central and provincial political arrangements, possess a very extensive institutional landscape. Its uncoordinated nature and related inefficiency have become the subjects of many evaluations.

## Technical Emphasis

Post-independence enthusiasm on project-based infrastructure development, which was substantially supported by international development assistance, saw a definitive tilt in administration toward construction and technology transfer aspects. The massive Indus Basin Project in Pakistan, Udawalawe and Mahaweli irrigation projects in Sri Lanka, a host of similar construction and rehabilitation projects elsewhere in South Asia, all brought with them this emphasis on the technical process.

In most instances, the Irrigation Departments which had evolved from the colonial period were partially dismantled to form larger, more powerful and resourceful parastatal bodies, mandated with infrastructure development objectives (Water and Power Development Authority or WAPDA in Pakistan, Mahaweli Authority of Sri Lanka or MASL). Their emphasis on the technical processes has polarized a decline in attention on the social side of irrigation management. This has also led to a gradual decline in the technical competence of those individuals remaining in or joining the operating agencies.

While the construction emphasis has shifted to the new, and more pampered (by the government), organizations like WAPDA and MASL, the rest of the institutional framework failed to capture the opportunity to develop other useful emphases. For instance, in Pakistan there is no organization with a mandate for farmer organization or coordinated irrigated agriculture. With an engineering emphasis given to the newly created On-Farm Water Management (OFWM) wings of the provincial Departments of Agriculture, they grew fast ahead of the other wings of the Department, and in the process of this growth, reduced the visibility and the effectiveness of Agricultural Extension.

## Laxed Rule Application and Excessive Political Intervention

Another major difference between pre- and post-colonial administrative styles in this sector was the relative neglect by the latter of the "rules" side of institutions. This is largely caused by the "softstate" attitude of overly politicized administration of new governments. Field studies in these countries clearly show that there has been a definite decline in institutional performance in the irrigation sector, which has worsened gradually since independence. Both farmers and agency staff recall the more disciplined irrigation behavior and the greater attention and supervision of officials at every level during that earlier period. A common feature of the present field situation is what they refer to as "political interference" on most aspects of management responsibilities. Performance evaluation of any type is virtually nonexistent in this context. The culture-bound orientation towards law-enforcement directly conflicts with this new development, and the outcome seems to be variable in different parts of the region.

## Good Officials and Bad Farmers

For individuals in position of authority, to place the blame of collective responsibility on the weaker group may be a universal phenomenon; farmers are a particularly vulnerable group vis-a-vis the irrigation officials. In South Asia, this is a very prominent feature of agency-farmer relationships,

## Recent Attempts at Institutional Changes

In almost **all** the South Asian countries, recent attempts at change are a special characteristic of the institutional framework. Most of these changes have been promoted by the development process itself, some by way of introducing democratic institutions, others by way of bringing about greater coordination, or management support. Following project-based development aid, donor interest in promoting improved institutions and more efficient management for project implementation, has been a conspicuous feature of these recent changes.

The creation of new structures such as WAPDA in Pakistan, MASL in Sri Lanka, and Central Water Commission (CWC) in India are examples of major attempts at structural change. Pakistan has been experimenting with Command Water Management Projects (CWMP) at a pilot level in selected canal commands in all of the four provinces; Sri Lanka is still evaluating its introduction **of** the Irrigation Management Division (IMD) to the traditional Irrigation Department and of the Project Management concept in system management; and India has proceeded a long distance with a number of Command Area Development Authorities (CADAs). Similar structural changes are being developed in Nepal (Pradhan 1989) and Bangladesh.

New laws, procedures and mechanisms for recovery of the costs of operation and maintenance are another attempt at institutional change in the region, This is basically a donor-driven initiative which is now being increasingly appreciated **as** an essential change to meet increased operation and maintenance costs.

Recent political imperatives of devolution of power also have led to some decentralization of responsibilities to the provinces. In the subcontinent, irrigation has become a state or provincial responsibility, and the states or provincial governments have established their own irrigation institutions. With this change, the original tilt towards centralism has **also** undergone change, although repercussions exist.

Despite these changes, however, the irrigation institutions in many of the South Asian countries appear to remain conspicuously static. Within the irrigation sector, the changes in institutions **lag** behind those that have taken place in the resource base and technology over the years; these changes also **lag** behind the changes that have taken place in other sectors. For this reason alone, the level of adequacy of the institutional framework for irrigation in South Asia is perceived as corresponding more to their original purposes, which were based on feudal and colonial requirements, than to present needs of social development.

## INTERACTION BETWEEN CULTURE AND NEW DEVELOPMENT INITIATIVES

The continuing interaction between deep-rooted irrigation culture and the effect of development initiatives can be seen in **all** the South Asian countries. Generally, where the interaction between these two factors has proceeded with less conflict, the role of the irrigation-related institutional framework appears to have been more supportive to irrigation management performance.

For instance, in Pakistan (and **also**, perhaps in North India) where forms of feudalism still stubbornly persist in influencing the socioeconomic aspects of rural life, the role of big landlords in irrigation conduct seems to be disruptive to achieving most of the performance objectives. Heavy investment in upgrading the physical system and increasing water availability has not been able to receive its due return, **as** the institutional framework remained basically static.

Another classic case of this interaction between culture and development inputs is the practice **of warabandi** (water distribution by fixed turns **of** fixed time duration) in northern parts of the subcontinent. The practice **is** dictated by deep-rooted cultural influences such **as** group

water rights, tolerance for power and authority, subservience to traditional leadership, etc., although more recent official interventions have tried to make it rigid and officious, but more equitable. Recent attempts to explore radical changes to the practice were readily turned down by the water users as well as the agency staff.

Relatively, this conflict between tradition and new development inputs has been less damaging in Sri Lanka (and also in South India) than in the northern subcontinent, because new development initiatives such as agrarian reforms, land settlement schemes, and attempts at farmer organization have proceeded without much hindrance, and with some degree of success. Concurrently, the culture variable here may also not have been as strong as in other contexts.

## INSTITUTIONAL FRAMEWORK

### Organizations

The South Asian model of the structural arrangements for irrigation management typically consists of three main components:

1. Traditional Irrigation Department (ID) for managing large systems
2. An offspring of the traditional ID, which was established for construction of large infrastructure development projects
3. An organization for developing and managing small schemes

The IDs are predominantly staffed by civil engineers and their support service groups. Generally, the preference of this staff is still towards construction activities, including rehabilitation, as against operational activities, or maintenance.

In Pakistan, the national planning documents have repeatedly pointed out the deficiency created by this preference in that the irrigation systems are not viewed or operated as production systems, and have recommended that ID staff should be given a special training in agriculture and brought closer to irrigated agriculture. Some coordination between these traditionally dichotomous agencies of irrigation and agriculture was attempted with the pilot CWMPs, but their evaluations do not present much of a success story. Recent World Bank proposals speak of the need to try more radical changes in the structures, where coordination is to be achieved more intensely on a canal command basis, and greater responsibility for water distribution be given to farmers.

In Sri Lanka, the ID functions were bifurcated into construction and "irrigation management" responsibilities: an IMD has been created within the ID itself and charged with the responsibility of coordinating all irrigated agriculture activities at the project or system level, thus trying to dilute the civil engineering flavor in the ID. The creation of MASL was basically for implementing the Accelerated Mahaweli Development Project of which the major effort was in constructing new regulatory reservoirs and irrigation canal systems. However, since relocating and settling of a large number of farmer families were also an important part of the project, MASL establishment included two sub-units of equal size and significance: Mahaweli Engineering and Construction Agency (MECA) and Mahaweli Economic Agency (MEA). The MEA in its structure saw a major departure from the traditional ID structure and also from the usual dichotomy between irrigation and agriculture, and evolved an integrated project management mode having the functions of water management, agriculture, community development, marketing and land administration, all under one management structure (Raby and Merrey 1989). In the "declared Mahaweli areas," MEA has tried to develop collaborative relationships with line

agencies such as the Irrigation Department and the Department of Agriculture, while maintaining its legally provided autonomous character.

In India, CADAs have also attempted a coordination between irrigation and agriculture involving different line agencies. In structure and performance, in terms of coordinating irrigated agriculture, CADAs appear to be more effective than Pakistan's CWMPs, but less effective than Sri Lanka's MEA.

Apart from this type of special attempts for coordinated irrigated agriculture, the typical organizational structure for irrigation in South Asia is one depicting unnecessary confusion and competition as described under *Recent Development Initiatives*. A sample of this wide distribution of responsibilities can be seen in Annex I and Annex II.

## Governance

Some steps towards greater autonomy from government involvement in managing irrigation systems have been taken in most South Asian countries. As mentioned in previous sections of the paper, these steps resulted only in creating semiautonomous parastatal bodies like WAPDA and MASL, and also in experimenting with structures for coordinating irrigated agriculture, as in the cases of CWMPs, MASL and CADAs. Most of these steps appear to have stopped short of developing into a clear trend. I see this as a result of the conflict between the "culture" and new development initiatives. Conventional wisdom and preference towards the trodden path have won over critical thinking and the desire to try new ideas. **Lack** of creativity and initiative is a strong characteristic of the static bureaucracy which the average South Asian institutional framework seems to represent.

Mainly as a consequence of the "soft state" phenomenon, the general law and order situation is refusing to show any improvement. This is aggravated by the skewed nature of distribution of wealth, income and political power. In this climate, it is not reasonable to expect a public opinion that is readily sympathetic towards privatization moves. In some of our field interviews, farmers clearly indicated a preference towards government-sponsored water distribution methods. So far, only pilot-scale attempts have been made in privatizing irrigation management, and that too in selected areas of groundwater use and small surface water systems. Effective farmer organization attempts also **lag** behind the successes achieved in other regions.

## Legal Framework

The history of irrigation rules in South Asia can be traced back to water regulation during the period of the Indus civilization and the later developments during the periods of Aryan, Greek and Arab influences (Radosevich 1975; Caponera 1978). However, the origin of written irrigation rules in the region does not go beyond the British colonial period.

As has been discussed in previous sections, the colonial period had left behind a fairly strong legal framework for irrigation in the subcontinent. These laws (most of which were enacted in the 1970s), manuals of procedure, and irrigation rules form the formal-rules component of the irrigation institutions. Using this strong base for most administrative purposes, subsequent governments have added a new set of laws as minor amendments and a few new laws and procedures. In some instances (e.g., amendments to the land laws and the Irrigation Ordinance in Sri Lanka), these changes have tended to dilute the old framework. Notwithstanding this, the present legal framework for irrigation seems to be impressive (see an example in Annex III). While the laws and procedures (or the formal rules) are adequate for most practical purposes, the real problem lies with their application.

In some countries, attempts have been made to introduce legal support to new development initiatives such as participatory management (Alwis 1990), tenancy laws, land reform and user association laws (Sri Lanka and Pakistan). Pakistan is one country which has established specific laws promoting farmer organizations (see Annex III), but has also demonstrated the futility of having legislation without a popular will to apply them, or to implement the reforms.

### **Informal Rules**

Irrigation behavior is determined not only by formal **rules** like written laws, regulations and procedures, but also by a number of informal rules such as traditional practices and values (elitism, caste system, landlordism, property inheritance and tenancy). In South Asia, where these practices have been sustained over a very long period of time, their effect forms part of the deep-rooted "irrigation culture." After years of tradition, they become a stable set of "rules" in their own right. Formal rules have a tendency to be subordinated by these informal rules, particularly when the countries have "soft **stale**" conditions. The overriding influence of informal rules over formal rules is seen as one of the dominant factors causing irrigation performance to be stagnant in Pakistan (Bandaragoda and Firdousi 1992).

### **Agency-Farmer Relationships**

This is one of the weakest elements in the institutional framework in most countries, although some have tried more earnestly than others. In large irrigation systems, where a joint-management mode will continue to be operative for some more time, the farmer-bureaucracy interface should be the focal point for institutional development. The present situation in South Asia varies widely from almost an abrupt end in agency involvement at the distributary outlet level in Pakistan, to federated farmer organizations managing the distributary itself in Sri Lanka, to totally farmer-managed command area systems in some parts of India, and many parts of Nepal.'

Another important feature is the varying mechanisms that the different countries have for dispute resolution and other interactions between farmers and agency staff. In Sri Lanka, a preseasonal planning meeting (cultivation meeting) has been in existence for a long time. Additionally, a system of "Open Kutcheri" days (dialogues between farmers and administrators) is also used for the agency staff and relevant political leaders to meet farmers in their own villages. The latter method has been practiced in the subcontinent widely, even during the colonial period. Overall, the quality of this interaction can be described as poor, and its general character as basically agency-dominated and patronizing.

## **CONCLUSION**

South Asia has an extensive institutional framework for irrigation built on a strong base which has been inherited from both the precolonial monarchical rule and the British colonial administration. The influences from these two periods, and the enthusiastic nationalism that followed the colonial period, have all combined to form an "irrigation culture" which seems to be continually impacting on the subsequent development initiatives. Consequently, the dynamism, that the more recent efforts could have generated by now, is missing in the present institutional

---

7 For details regarding the limited functions of the government and the tradition of nonintervention in irrigation water management at the community level in Nepal, see Pradhan 1989.

framework. What one can find today is an unhealthy mixture of tradition and modernity in which the formal institutions play a passive role, as though trapped between these two opposing forces.

## Bibliography

- Alwis, Joe. 1990. Legal support required for effective resource mobilization under the new participatory management policies, in Resource Mobilization for Sustainable Management, proceedings of a workshop held at Kandy, Sri Lanka. Colombo: IIMI.
- Bandaragoda, D. J. and Firdousi, G. R. 1992. Institutional factors affecting irrigation performance in Pakistan : research and policy priorities. IIMI Country Paper - Pakistan No. 4.
- Caponera, D. A. 1978. Water laws in Muslim countries. Rome, Italy: FAO, 2 vols. vi, 223p; iii, 311p. Microfiches (FAO irrigation and drainage papers nos. 20/1 and 20/2).
- Caponera, Dante A. 1968. Evolution and concepts of water legislation, Annals Juris Aquarium. Proceedings of the International Association for Water Law, September 1968.
- Chambers, Robert. 1988. Managing canal irrigation: Practical analysis and lessons from Asia. New Delhi, India: Oxford and IBH Publishing Co.
- Lusk, M. W. and Parlin, B. W. 1988. Bureaucratic and farmer participation in irrigation development, WMS Report 89, Logan, USA: Utah State University.
- Merrey, Douglas J. 1992. Overcoming artificial institutional barriers: linking farming systems with irrigation management research. Paper prepared for presentation at the Asian Farming Systems Symposium, 2-5 November 1992, BMICH, Colombo, Sri Lanka.
- Malbotra, S.P. 1982. The Warabandi system and its infrastructure. Publication No. 157. New Delhi: Central Board of Irrigation and Power.
- Nasir, A.D. 1981. A practical treatise on analytical study of Canal and Drainage Act (VII of 1873). Lahore, Pakistan: Mansoor Book House.
- National Commission on Agriculture. 1988. The report of the national commission on agriculture. Islamabad, Pakistan: Ministry of Food and Agriculture.
- Nayman, Oguz B. 1988. Information-seeking habits of farmers: an exploratory survey. Punjab-Pakistan (unpublished report).
- Pradhan, P. 1989. Patterns of irrigation organization in Nepal : a comparative study of 21 farmer-managed irrigation systems. IIMI Country Paper - Nepal No. 1.
- Raby, N. and Merrey, D.J. 1989. Professional management in irrigation systems : a case study of performance control in Mahaweli System H, Sri Lanka. IIMI Country Paper - Sri Lanka No. 1.
- Radosevich, George E. 1975. Water user organizations for improving irrigated agriculture: application to Pakistan, Water Management Technical Report No. 44. Fort Collins, USA Colorado State University.
- Wittfogel, Karl. 1957. Oriental despotism: a comparative study of total power. New Haven: Yale University Press.



## **The Institutional Framework for Irrigation in Pakistan**

Pakistan has inherited a strong institutional base for irrigation, the origin of which can be traced to the mid-19th century. With the Irrigation and Drainage Act promulgated in 1873, the state intervention on irrigation issues started to be effected through a government bureau, and was thus the beginning of the present Irrigation and Power Department in the Punjab Province. Provincial Irrigation Departments (PIDs) in other provinces are the offshoots of their older Public Works Departments, but for both legal procedure and departmental traditions their parentage can be traced to the original state irrigation agency created by the British with the Act of 1873. The organizational culture of all these PIDs is strongly linked with the rigid hierarchical administrative setup of the colonial period.

However, the application of rigid formal rules formulated over a century ago has been severely eroded by the informal social practices which have evolved with the rapid social change since independence. The rigid formal rules that served the earlier period well are now no longer functional in view of the social dynamics of the present-day irrigation sector. To this extent, PIDs continue to be strong organizational structures, but less effective in meeting the present social demand relating to irrigation operations.

Provincial Agricultural Departments (PADs), though of slightly more recent origin, are also related to preindependence institutional creations. PADs were originally entrusted with agriculture extension and adaptive research as their main functions, and their technical importance increased significantly during the green revolution days of the 1960s. More recently, irrigation-related construction work was also given to PADs through the donor-assisted watercourse improvement activities, popularly known as the On-Farm Water Management (OFWM) program. The newly added responsibilities, and substantial budgetary allocations associated with them, tended to provide high visibility to the OFWM wings of the PADs. Consequently, there has been a tendency for the PADs' focus of attention to shift away from their main role of agriculture extension work.

Traditionally, except for the resolution of water-related disputes among the farmers, the Irrigation Departments have restricted their jurisdiction, and more importantly their interest, to the main and distributary canal systems, leaving the area below the *mogha* (distributary outlet) to the Departments of Agriculture. To date, this sharp separation of responsibilities, above and below the *mogha*, characterizes the institutional framework for irrigated agriculture in Pakistan, and tends to affect the operation and maintenance of the system as a whole. It also serves as a symbol of a "great divide" between irrigation and agriculture, which runs through the framework from field-level operators to provincial-level departments, and to federal-level ministries.

Building on the strong institutional base left behind by the colonial administration, Pakistani authorities have added some very important and useful elements to form a fairly complex institutional framework for irrigated agriculture. With the federation of provinces, which was established in Pakistan early in the 1970s, irrigation remained a provincial responsibility, while, for accomplishing its major responsibility of planning for national development in which irrigated agriculture continued to play a very significant role, the Federal Government created its own Ministries of Water and Power (MWP), and Food, Agriculture and Cooperatives (MFAC). The Planning Commission (PC) with administrative support from the Planning and Development

Division, and the Ministry of Finance (MF) were to perform their assigned supervisory functions in overall planning and resource allocation.

In the preparation of five-year plans and the annual development plans, the Planning Commission plays a pivotal role and tries to bring about a planning discipline among the various ministries and departments by requiring them to follow a specific process. For major projects, five specific PC forms and instructions are to be followed: PC-I for construction or any other developmental activity, PC-II for investigation, PC-III for quarterly progress reports, PC-IV for completion reports, and PC-V for monitoring of benefits. Out of these, PC-I is used as the basis for project choice decisions, and is to be prepared similar to a normal project feasibility report with all relevant technical and financial details, and economic and other decision criteria.

Consideration of various project policy aspects and decisions thereon takes place at different levels.<sup>8</sup> For instance, for a project costing more than Rs. 60 million, the process starts with the preparation of a concept paper by the sponsoring department. Concept clearance is given by the Executive Committee of the National Economic Council (ECNEC) which is the highest administrative body for project choice decisions. A PC-II is then prepared by the department detailing the investigation requirements and work plan, and once this work is completed a PC-I is prepared with details of project implementation. The PC-I proceeds through several approval levels: the Departmental Development Working Party (DDWP) or the Provincial Development Working Party (PDWP), and then the Central Development Working Party (CDWP) at the Federal Government level, involving all agencies and the ministries concerned including Provincial Planning and Development Departments (PP&DDs). Finally, the PC-I is considered by the ECNEC, and the approvals of the provincial and the national assemblies are sought depending on the nature of policy and resource-allocation needed.

Research relating to irrigated agriculture is initiated by specific wings of line ministries at both federal and provincial level, while their activities are supplemented by the Ministry of Science and Technology (MST) and the universities under the aegis of the Ministry of Education (ME). Specifically deployed for this purpose are the Pakistan Agriculture Research Council (PARC) and the National Agriculture Research Centre (NARC) of the MFAC, Pakistan Council for Research on Water Resources (PCRWR), Drainage Research Institute of Pakistan (DRIP) and the National Documentation and Library Information Center on Water Resources (NADLIN) of MST, and the Center of Excellence for Research in Water Resources (CEWRE) of the University of Engineering and Technology in Punjab. Research wings of the Provincial Irrigation Departments such as the Irrigation Research Institutes (IRI) in Punjab and Sind, and the Directorate of Land Reclamation (DLR) in Punjab, and those of the Provincial Agriculture Departments such as the Agriculture Research Institute (ARI) and the Rice Research Institutes (RRI) in Punjab and Sind add to this overall research institutional setup.

The Water and Power Development Authority (WAPDA), a semiautonomous or parastatal body created in February 1958, can be recognized as a major postindependence contribution in institutional development for Pakistan's irrigation sector. When it was established in 1958, WAPDA became an agency of West Pakistan, and remained so until 1970 when the West Pakistan's One-Unit arrangement returned to the pre-1958 system of separate provinces. With this change, WAPDA became a federal agency and was given much greater prominence than it had during its formative period as a West Pakistan agency. The prominence corresponded to the new responsibility given to WAPDA for assisting the Federal Government in its role in resource allocation for irrigation and power development and, for planning and executing all major development projects in the sector. With the advantage of this prominent place in the institutional

---

<sup>8</sup> The revised procedure for approval of development schemes and powers of various authorities to sanction development schemes are given in Circular No. 20 (1)DA/PC/87, dated 15 November 1987, issued by the Planning and Development Division of the Federal Government.

framework, WAPDA is able to play, and has demonstrably played, an important role not only in irrigation-related policy, but also in research, assisting the federal authorities in many policy initiatives. The International Waterlogging and Salinity Research Institute (IWASRI), Mona Research Station, SCARP Monitoring Organization (SMO), the Lower Indus Water Management and Reclamation Research Institute (LIM), and Watercourse Monitoring and Evaluation Directorate (WMED) are WAPDA's subsidiary organizations or units established for specific research, monitoring and evaluation functions.

Annex II provides a functional and hierarchical distribution of the various units of the institutional framework in Pakistan's irrigated-agriculture sector.

## Institutional Framework for Pakistan's Irrigated Agriculture

Irrigation-slat4 intervention	Policy/Planning	Design and construction	Operation and maintenance	Research
<b>Wafer Acquisition</b> River Diversion Reser- voir Small Dams	ECNEC, CDWP, DDWP, MWP, MAFC, PC, MF PDWP, WAPDA	WAPDA, PID	WAPDA, PID	<b>MWP</b> (WAPDA) MAFC
<b>Wafer Distribution</b> Main Canal Distributary Minor	PP&DD, PID, PAD	WAPDA, PID	<b>WAPDA, PID</b>	
<b>Water Use</b> Watercourse Field				

### Notes:

CDWP = Central Development Working Party	NARC = National Agriculture Research Centre
CEWRE = Centre of Excellence in Water Resources	NESPAK = National Engineering Services of Pakistan
DDWP = Departmental Development Working Party	OFWM = On-Farm Water Management
DLR = Directorate of Land Reclamation	PAD = Provincial Agriculture Department
DRIP = Drainage and Reclamation Institute of Pakistan	PARC = Pakistan Agriculture Research Council
ECNEC = Executive Committee of the National Economic Council	PC = Planning Commission
IRI = Irrigation Research Institute	PCRWR = Pakistan Council for Research on Water Resources
IWASRI = International Waterlogging and Salinity Research Institute	PDWP = Provincial Development Working Party
LIM = Lower Indus Water Management and Reclamation Research Institute	PID = Provincial Irrigation Department
MAFC = Ministry of Agriculture, Food and Cooperatives	PP&DD = Provincial Planning and Development Department
ME = Ministry of Education	RRI = Rice Research Institute
MF = Ministry of Finance	SMO = SCARP Monitoring Organization
Mona = Mona Reclamation Research Project	WAPDA = Water and Power Development Authority
MST = Ministry of Science and Technology	WMED = Watercourse Monitoring and Evaluation Directorate
<b>MWP</b> = Ministry of Water and Power	
NADLIN = National Documentation Centre	

## Some Irrigation-Related Laws in Pakistan

- 1 Canal and Drainage Act (VIII of 1873) as amended by Canal and Drainage (Amendment) Act (XIV of 1952), Canal and Drainage Extension Act (XXIV of 1964), Canal and Drainage (West Pakistan Amendment) Ordinance (XXIII of 1965) and Act (VII of 1968), Canal and Drainage Extension to III Lora Canal of Bannu District Ordinance (XIII of 1969), Canal and Drainage (West Pakistan Amendment) Ordinance (I of 1970) and (West Pakistan 2nd Amendment) Ordinance (IV of 1970), Canal and Drainage Extension to Rohri Canal Area Ordinance (XVII of 1970), Canal and Drainage (Punjab Amendment) Ordinance (XVIII of 1971), and Canal and Drainage (Punjab Amendment) Act (XXXII of 1975).
2. The Punjab Minor Canals Act (III of 1905).
3. Rules and Rates under the Punjab Minor Canals Act (1906).
4. Sind Irrigation Act (VII of 1879).  
Bund Manual, P.W.D. Government of Sind (1954).
- 5 Punjab Soil Reclamation Act (XXI of 1952), as amended by:  
The Punjab Soil Reclamation (West Pakistan Amendment) Ordinance (V of 1964),  
The Soil Reclamation (Punjab Amendment) Ordinance (VI of 1970), and  
The Punjab Soil Reclamation Board (Reclamation Fee) Rules (1965).
6. The West Pakistan Land and Water Development Board (Reclamation Fee) rules (1965).
7. Hand-Book of Professional Orders for the Guidance of Officers of the Irrigation Department, Punjab and North West Frontier Provinces (1914), 2nd Edition 1925.
8. Irrigation Manual of Orders (1912), 2nd Edition 1929, 3rd Edition 1940, 5th Reprint 1964.
9. Manual of Irrigation Practice (1943, Reprint 1963).
10. Schedule of Rates (1963 1964), Vol.I, Part I (Specifications for Material Construction), Vol.I, Part II (Specifications for Execution of Works), Vol.II, Part I (Analysis of Material Quantities), Vol.II, Part II (Analysis of Labour), Vol. III, Part III (Schedule of Composite Rates).
11. Public Works Department (Irrigation Branch) Revenue Manual, 4th Edition 1955, 6th Reprint 1987.
12. Water Users' Association Ordinances (Provinces), 1981

# **Institutional Aspects of Irrigation in South America: The Case of Peru**

*Klaus Urban*<sup>9</sup>

## **Irrigated Area in Latin America**

IN 1990, THE total irrigated area in Latin America and the Caribbean amounted to 15.7 M ha (see Table I). In five countries the irrigated area was larger than 1 M ha: Mexico (5.2 M), Brazil (2.7 M), Argentina (1.7 M), Chile (**1.3 M**), and Peru (**1.3 M**). Between 1965 and 1990 the annual increase of the irrigated area in all of Latin America and the Caribbean was approximately 220,000 ha. ~~Three~~ countries "provided" 71 percent of this increase: Brazil (83,000 ha per year), Mexico (57,000 ha per year) and Cuba (16,000 ha per year).

If we observe the recent development in the different countries we can see that, with the exception of Brazil, in those countries where irrigation plays a major role the total irrigated area has not changed significantly in the last years. Moreover, the degradation of many irrigation systems has led to a stagnation in the total area of irrigated lands. This stagnation has been attributed to a variety of factors, one of which is the inability of the existing institutional sector to provide the proper environment for sustainable operation and maintenance of the irrigation systems (Urban 1990).

## **Contemporary Water Management and Water Rights Systems in Latin America**

In water management in Latin America and the Caribbean, there are only very few genuine examples of institutions possessing a multipurpose viewpoint. This is not surprising in societies where the primary goal remains the raising of productivity. It is the force of this reality which has prevented the ideas of resource-oriented and multipurpose management from having a more than very limited influence in the Latin American Region (Lee 1990).

In spite of considerable variations from country to country we can identify three general categories of water management systems in the region (Lee 1990, 19–21):

1. Water management systems which are characterized by the existence of many active public and, in some case, private institutions with only weak central coordination (Argentina, Bolivia, Chile, Colombia, Guatemala, Paraguay, Uruguay and Venezuela)
2. Water management systems which have central coordination of policy, but with institutional dispersion of responsibilities for the specific uses of water (Brazil, Costa Rica, El Salvador, Panama and Peru)

---

<sup>9</sup> Independent Consultant, Wiesbaden, Germany.

3. Water management systems with centralization of authority and with little or no dispersion of responsibilities either for individual uses or by regions (Cuba, Ecuador, Honduras and Mexico)

*Table 1. Irrigated areas (in '000 ha) in Latin America (1965 – 1990)*

	1965	1970	1975	1980	1985	1990
<b>MEXICO</b>	3,750	3,950	4,479	4,980	5,285	5,180
<b>BRAZIL</b>	610	796	1,100	1,600	2,100	2,700
<b>ARGENTINA</b>	1,620	1,700	<b>1,440</b>	1,580	1,620	1,680
<b>CHILE</b>	<b>1,091</b>	1,180	1,242	1,255	1,257	1,265
<b>PERU</b>	<b>1,060</b>	<b>1,106</b>	1,130	1,160	1,210	1,260
<b>CUBA</b>	493	520	580	762	861	900
<b>ECUADOR</b>	450	470	510	520	540	552
<b>COLOMBIA</b>	235	250	300	400	465	520
<b>VENEZUELA</b>	225	284	212	240	251	<b>265</b>
<b>W.M. REPB.</b>	115	125	140	165	198	225
<b>BOLIVIA</b>	75	80	120	140	160	165
<b>GUYANA</b>	<b>109</b>	115	120	125	127	130
<b>EL SALVADOR</b>	20	20	33	<b>110</b>	<b>110</b>	120
<b>URUGUAY</b>	35	52	57	79	97	110
<b>HONDURAS</b>	66	70	80	82	85	90
<b>COSTA RICA</b>	26	26	36	61	110	118
<b>NICARAGUA</b>	<b>18</b>	29	67	80	83	85
<b>GUATEMALA</b>	43	56	60	68	75	<b>78</b>
<b>HAITI</b>	40	60	70	70	70	75
<b>PARAGUAY</b>	40	53	55	60	65	67
<b>SURINAME</b>	<b>15</b>	27	33	42	55	59
<b>PUERTO RICO</b>	39	39	39	39	39	39
<b>JAMAICA</b>	24	24	32	33	34	35
<b>PANAMA</b>	18	20	23	28	30	32
<b>TRINIDAD</b>	11	15	18	<b>21</b>	22	22
<b>ALL COUNTRIES</b>	10,228	11,067	11,976	13,700	14,949	15,772

In nearly all of the Latin American countries the water rights systems are strongly influenced by the Spanish legislation. They show four common features (CEPAL 1980):

1. State ownership of water
2. Concession of water rights and permits through the state
3. Priority systems to regulate the water use
4. The existence of one law or legal body in water affairs

It must be noted, though, that the abovementioned water management and water rights systems have only limited influence in large parts of the mountainous regions of the Andes. Here,

small-scale community irrigation prevails—based on traditional water rights and traditional organizational procedures.

Recent innovations in water management policy are noted in some countries, e.g., Brazil and Chile. Though the innovations are, in themselves, very different, they point to the possible future creation of national water management systems based on the concept of integrated river-basin management (see Lee 1990, 25–27). In Brazil, the policy initiative has come from the Federal Government. The aim was the reorganization of the public administration related to water management. In Chile, although the policy innovations have come from the government, further institutional development will depend to a larger extent on user initiative. Here, the changes (privatization, creation of a market in water rights) reflect a complete reversal of the historical tendency in Chile which was, as in other countries of the region, oriented toward the centralization of water development and management in one or more public agencies. Also in Peru, the government has initiated steps towards a concept of integrated river-basin management. River-basin management committees have been established throughout the country. However, their real influence is still very limited, because of the limited funds available to make them operate effectively.

### **Institutional Arrangement: The Case of Peru**

Peru is one of the countries where we have a water management system with a central coordination of policy, but with institutional dispersion of responsibilities for the specific uses of water. Coordination is achieved through the existence of formal mechanisms at the interministerial level, reporting directly to the President. The coordination mechanisms are institutionalized through the Supreme Water Council (Consejo Superior de Aguas). Within the Ministry of Agriculture the General Directorate of Water and Irrigation acts as the secretariat for the Supreme Council.

Among the institutions involved in the management of irrigation systems the following play a major role:

- **Ministry of Agriculture (MA).** The Ministry of Agriculture draws up and executes irrigation projects. It participates directly in the planning, use and control of water resources for agricultural purposes. It carries out its activities through the General Directorate for Water, Soils and Irrigation (national level), the Regional Directorate for Water and Soils (regional level), and the Technical Bureau of the Irrigation District (local level). The Ministry of Agriculture also grants water rights according to the Water Law enacted in 1969.
- **National Development Institute (INADE).** All major irrigation projects, especially those financed through foreign loans, are carried out directly by “Special Project Agencies” organized under INADE. The “Special Project Agencies” are responsible for the construction, operation and maintenance of the major infrastructure of these systems until they are handed over to the regional authorities.
- **Water User Associations.** Following the 1969 Water Law, user organizations have been established at the regional (Juntas de Usuarios) and local levels (Comisiones de Regantes). The 1969 Water Law provided the conditions for a more thorough participation of the water users in the administration, conservation and distribution of the water resources. Together with the Technical Bureau of the Irrigation District they elaborate the Irrigation Plan (Plan de Cultivo y Riego) of the District.



- **Coordination Committees.** In situations of extreme water scarcity and conflict, special Coordination Committees decide on the reduction of the water provision and on how the different users are affected. The Coordination Committees are selected from representatives of the Regional Office of the Agrarian Ministry and representatives of the water **users**.

As mentioned above, this institutional setup is valid mainly for the “modern” irrigation sector in the coastal region of Peru. In the mountainous regions these institutions only play a role in a very few areas, especially in those where government-controlled irrigation schemes have been constructed.

As far as the management of the large-scale schemes on the Peruvian coast is concerned, the institutional arrangement described above has had a decisive impact on the implementation and operation of the schemes (see Urban 1990). It is very difficult to develop an overall strategy in the management of the projects because the responsibilities for the following lie in many different hands (see example in Figure 3).

- Construction (Special Project Agency)
- Operation (technically: Special Project Agency; administratively: Technical Bureau of the Irrigation District and Coordination Committees)
- Maintenance (main system: Special Project Agency; tertiary system: Users)
- Administration and Control of Water Use (Technical Bureau of the Irrigation District)

The consequences of such an institutional dispersion for the management of the irrigation systems can be severe. The Tinajones Irrigation System on the northern Peruvian Coast is a clear example of this (see Urban 1990, 98–114; 157–182). The system was designed to regulate the irrigation of approximately 80,000 ha in the Chancay **Valley** in the Department of Lambayeque. For this purpose a 300 M m<sup>3</sup> reservoir and a new distribution system were constructed. The construction of the reservoir and main parts of the new lined canal system was completed in 1967. The aim of the project was to regulate and stabilize the irrigation of the existing irrigated area. Unfortunately, this aim could never really be met.

As a result of the Agrarian Reform promulgated in 1969 the irrigated area in the Chancay Valley was thoroughly expanded. About 20,000 ha of additional land and the respective water rights were granted to “new users,” mainly small farmers. As a consequence—since the new irrigation system had been planned to serve a smaller area—the needs of a large number of users could only be met in years with abundant rainfall. As dry years, especially those between 1975 and 1982, were extremely dry, severe conflicts arose. In those years, the reservoir was usually emptied completely in the initial phase of the season (November – December). If, later in the season, at least some additional rainfall in the Andes brought water to the valley, a larger part of the farming community could at least save their crops. However, if there was no significant rainfall from January to April, as in most years between 1975 and 1982, a large number, sometimes more than 50 percent, of the farmers lost their crops.

To some extent, the disappointing experiences in the years between 1975 and 1982 have to be attributed to the decision of the political authorities to expand the total number of water users to be served by the system. However, the impacts of the droughts could have been drastically reduced, and the efficiency of the system significantly improved, if an effective water management had been applied. An effective management of the Tinajones System, especially in the **dry** years, would have implied, above all, the adoption of a well-balanced cropping pattern and the restriction of the water use on sandy soils. However, in spite of various attempts, the representatives of the Technical Bureau of the Irrigation District were unable to implement an

effective water management policy, not only in the dry years, but even in the years with sufficient rainfall.

Figure 3. Institutional arrangement, Tinajones Project (Peru)

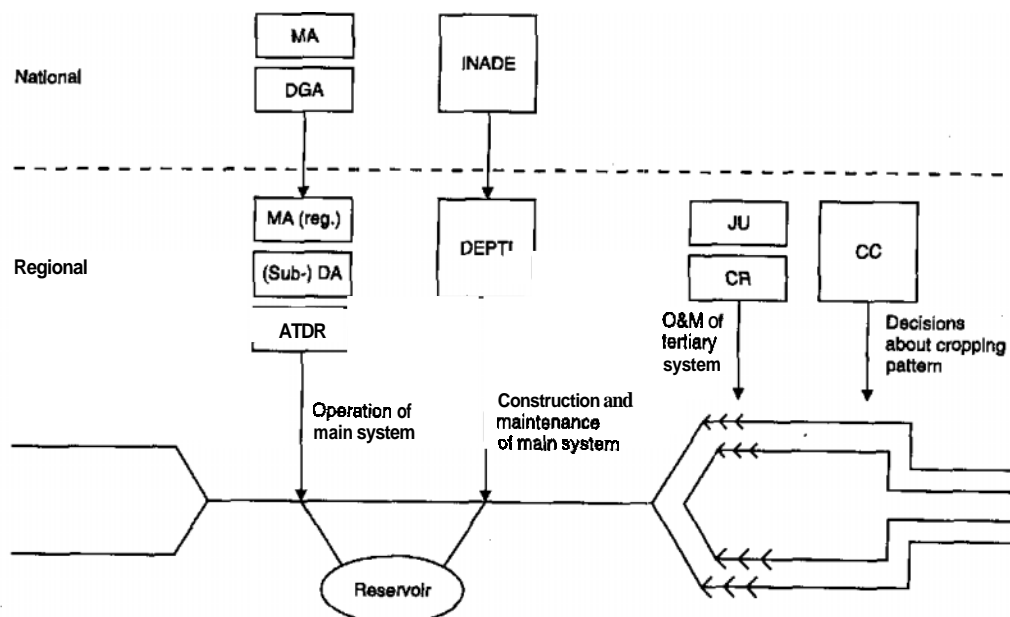

- MA = Ministry of Agriculture.  
 DGA = General Directorate for Water Development.  
 ATDR = Regional Agency for Water Administration.  
 INADE = National Institute for Development.  
 DEPTI = "Special Project" Agency.  
 JU/CR = Water User Associations.  
 CC = Coordination Committee.

How could that happen? Analyzing the situation throughout the years, we can see that the Technical Bureau of the Irrigation District was practically the only one of the role players involved that was really interested in implementing an effective water management policy. However, the Technical Bureau was politically too weak to have a decisive influence. When the representatives of the Technical Bureau tried to convince the other members of the Coordination Committee to reduce the areas of the highly water-consuming crops, they were outnumbered by the user representatives who had a majority in the committee. The situation worsened, when the Coordination Committee even accepted a significant rise in the amount of rice crops in the valley. Since rice consumed far more water than most of the other crops in the valley, this decision increased the scarcity not only in the dry years but in others. Unfortunately, the presence of the Director of the Regional Office of the Ministry of Agriculture as Head of the Coordination Committee did not help prevent the users from taking these decisions that were largely induced by short-term interests.

On the contrary, since the Director of the Regional Office of the Ministry of Agriculture pursued aims different from those of the Technical Bureau of the Irrigation District, the policy of his office even reinforced the users' tendencies. Since the main aim of the Ministry of Agriculture was to provide cheap grain to the larger cities, it adopted an overall policy in favor of rice production by granting a fixed price for rice and subsidies for its marketing. This policy counteracted the intentions and interventions of the Technical Bureau of the Irrigation District. The staff of the Technical Bureau of the Irrigation District was not only too weak to enforce the implementation of an effective water management strategy but even lacked the means (equipment, staff) to control the limited number of corrective measures that had been adopted (Urban 1990, 157-182).

As in the Tinajones example, in most of the large-scale irrigation schemes on the Peruvian Coast the dispersion of responsibilities, and even more important, the dispersion of the interests of the different participating parties, prevented efficient and effective water management strategies geared towards the needs of the specific systems (see Urban 1990).

## Water Rates in Peru

The water rates and fee regulations were formerly established in the General Water Law and its regulations. The rates and fees are based on three components: water use, service and amortization. In 1981, new water rate regulations were approved. They include different rates according to the type of use, i.e., agricultural or nonagricultural. The rate for water used for agricultural purposes is calculated on the basis of the Board of Users' income, the water rate and amortization.

The component of the Board-of-Users' income is that part of the rate used to cover overhead expenses and the cost of developing the water resource for irrigation purposes; this income is used to finance the budget at the level of the activities scheduled by the Board of Users. The funds collected are assigned as follows: a total of 10 percent is allocated for the execution of studies on the protection of hydrographic basins and the remaining 90 percent is used for the following (see Lee 1990, 110):

- Water management and distribution
- Conservation and improvement of waterways
- The costs of collecting water rates
- Operating and payroll costs of the Board of Users
- The costs of irrigation-water and/or groundwater studies
- The maintenance of a reserve fund for emergencies

The water-rate component is that part of the rate paid to the State as a tax on the use of water as a public utility. This revenue which consists of 10 percent of the component of the Board-of-Users' income goes to the public treasury. The amortization component is that part of the rate supposed to be paid back to the State as reimbursement for public investment in irrigation works and in works designed to improve irrigation and/or drainage; it is paid into the public treasury, and its value is established annually by the Agrarian Ministry.

Up to now, this system of water rates could not be applied effectively in Peru. In Tinajones, as in most other projects, the water rate applied does not provide a means of recovering the investments made; indeed the amount charged does not even cover the operation and maintenance expenses. Furthermore, due to the inadequate collection schedule and the delays in payments the

real value received is negligible and may be characterized as purely symbolic (Lee 1990; Urban 1990).

## References

- Comisión Económica para América Latina (CEPAL). 1980. Agua, desarrollo y medio ambiente en América Latina, Santiago de Chile.
- Lee, Terence. 1990. Water resources management in Latin America and the Caribbean. Westview Press, Boulder.
- Ministerio de Agricultura, Pesca e Alimentación. 1986. Conferencias del seminario iberoamericano de riego y drenaje, Madrid.
- Urban, Klaus. 1990. Large-scale irrigation schemes in Peru. Political, institutional, and economic aspects of their planning and implementation (in German). Breitenbach publishers, Saarbrücken/Fort Lauderdale.

# Institutional and Organizational Arrangements in Australia

*D. J. Constable*''

## INTRODUCTION

ORGANIZED IRRIGATION DEVELOPMENT commenced in Australia just over 100 years ago. Prior to European settlement and colonization, which began in 1788, there was no agricultural development. The continent was sparsely populated, and the indigenous inhabitants were hunters and food gatherers.

Australia is the driest of the world's continents. The average annual runoff in its largest river System, the Murray, is only 14 million liters per square kilometer compared with values of between 180 and 600 for the major systems in other continental land masses. Table 2 illustrates this low quantity of runoff.

Irrigated agriculture accounts for over 80 percent of the water extracted from the rivers. The introduction of irrigation just over 100 years ago led to the necessity to develop water laws to facilitate such development. The competition for water for industrial and municipal use and the need to move toward a sustainable approach to resource development and environmental management have resulted in a major review of the water law and the institutional arrangements for water resources development and management over the last decade.

Under *Australian Political Jurisdictions* is given a brief outline of the Australian political system as a federation of sovereign states. In the subsequent sections, some points have been highlighted under the headings of the five subject areas for this Workshop.

*Table 2. Comparative runoff rates in some major river basins.*

Basin	Country/Continent	Mean annual runoff (mm; or MI/km <sup>2</sup> )
Amazon	South America	633
Changjiang	China	533
Zaire	Africa	510
Mississippi	United States	180
Murray	Australia	14

---

10 Professor D. J. Constable was formerly Director of the University of Melbourne, Parkville, Vic 3052. Australia.

## AUSTRALIAN POLITICAL JURISDICTIONS

At the end of the nineteenth century, Australia comprised six British colonies, each with largely sovereign legislatures which had power to make laws effective for the particular colony.

The Federal Commonwealth of Australia was created in 1901 with the colonies then becoming the States of New South **Wales**, Victoria, South Australia, Western Australia, **Queensland**, and Tasmania. Unlike federations in other parts of the world, the constitution under which the Australian federal system operates placed strong emphasis on preserving the structure and sovereignty of the States. Only specific powers considered to be best controlled in the national interest were ceded to the Commonwealth Government, e.g., foreign affairs, defense, trade, immigration, and financial and economic policy.

Responsibility for land and water management remains with the State Governments. However, political boundaries have little relevance to catchment boundaries and, in the case of River Murray, the main stem of the river forms the boundary between New South Wales and Victoria. There is still some difficulty in precisely defining the boundary in legal terms.

The current position in Australia therefore is that there are seven independent governments, one for each of the six sovereign States and the Commonwealth Government, with interests in the management of natural resources (the Northern Territory has quasi-sovereign status but is under the jurisdiction of the Commonwealth Government.).

The third level of government, municipal (or local) government has no constitutional standing, but is established under State legislation. The municipal government provides a range of community services, with powers to recover costs from the community by rates and charges.

While the States have constitutional responsibilities for the development and management of water supplies, the Commonwealth of Australia, in its responsibility for the management of the economy and the equitable distribution of national income, makes decisions which have important implications for the timing and cost of water supplies; for example, monetary and employment creation policies. On the other hand, decisions by the States in respect of their responsibilities have an impact on the cost of living and the cost-structure of industries, for example, water-pricing policies.

This distribution of power and responsibilities has been a significant element in determining the institutional arrangements for water-resources planning and management. For example, the recovery of operation and maintenance costs for water services from beneficiaries has been practiced exclusively through the State agencies. However, to ensure that, as far as practicable, water-resources planning, development and management are soundly based, the Commonwealth **has** provided funds since 1964 for collaborative Commonwealth/State programs to accelerate the assessment of **surface** and underground water and, since 1968, for water research.

The Commonwealth has also provided assistance for capital works for water-supply, flood-mitigation and salinity-control projects in accordance with State priorities and for initiating and accelerating a number of projects of national significance.

## ORGANIZATIONS AND THEIR ALLOCATED FUNCTIONS

Land and water management are a State responsibility. While each State legislature enacts its individual legislation, the essential features in water legislation are broadly similar in all States. The following brief **summary** is indicative of events in the State of Victoria, which is representative of the situation in the eastern **States**.

The introduction of irrigation in the 1880s signaled the commencement of a process where common or customary law was replaced by legislation to facilitate State development. The Irrigation Acts of this time prescribed that the Crown (State) has the primary right and responsibility for water, and private rights are derived from the State. This fundamental provision has remained the cornerstone of legislation in all States.

The original Irrigation Act authorized the establishment of local management bodies (called Irrigation Trusts) with powers to divert water from rivers for the establishment of irrigation districts.

By the early 1900s most of these Trusts had failed financially, because of the variability of river flows and the absence of regulating storage. In view of the generally large catchment areas and sparse population, the communities within catchments have limited capacity to pay for authorities capable of providing the range of expertise and services dedicated within one catchment are limited.

Following the failure of the Irrigation Trusts, the Governments of the day moved to establish arrangements to manage water resources at the State level.

In the State of Victoria, the Water Act of 1905 established the State Rivers and Water Supply Commission, an autonomous body with wide powers to investigate the extent of the State's Water Resources, prepare proposals for their development, implement projects and subsequently manage them. The 1905 Act also empowered the Commission, in accordance with the provisions in the legislation to oversee the establishment of authorities to develop and manage water services to urban communities outside the capital city, where these services were provided by a separate autonomous authority (the Metropolitan Board of Works).

This arrangement worked satisfactorily for a long period of development between 1905 and 1970. The Metropolitan Authority was financially autonomous, with powers to raise capital by loans within global limits approved by the State Governments. The global limits of borrowing by each State are fixed annually by the Commonwealth after consultation with the States.

The State Rivers and Water Supply Commission, on the other hand, was not financially autonomous. Its functions included a range of business services, e.g., supply of water for irrigation and urban water supply, a range of State services for which there were no direct beneficiaries, e.g., gauging of rivers and assessment of the extent of surface water and groundwater resources, and a number of regulatory and administrative functions. In respect of its business services, the Commission was expected to be financially self-sufficient. In respect of irrigation, particularly the recovery of all costs from users was not feasible, and in cases of other services Government subsidies were provided to underwrite the costs of services, particularly to small communities, on the grounds of social equity.

The Commission was in essence, the Basin Authority for the whole of the State, with the Water Legislation providing mechanisms for the devolution of responsibility to locally managed authorities, where this was seen to be appropriate.

These institutional arrangements resulted in the two central authorities developing as powerful, bureaucratic, technically competent authorities with a total range of expertise embracing the whole range of functions from dam construction through to the operation and management of distribution systems.

From 1905 to 1970, these institutional arrangements were generally satisfactory and this was a period during which extensive development of water resources occurred. The needs of the metropolitan community could be met by resources developed within the catchment dedicated for this purpose. Elsewhere in the State, community requirements were met by developments within individual basins, and by an extensive system of inter-basin transfers, for which decisions were made by a mixture of bureaucratic and political processes.

By 1970, however, the needs of the Metropolitan Authority had outgrown the resources available within the basin, and new inter-basin transfers were necessary. Friction between the two

authorities, emerging environmental concerns, and community desires for greater and more rapid devolution of powers from the Commission led to the restructuring of these arrangements. In 1976, a coordinating ministry was developed, without any real change in the power and role of the two major authorities. In 1984, a further restructuring occurred with the strengthening of the powers of the ministry as the Department of Water Resources, relative to overall State strategic planning and general coordination within the water sector.

The relative independence of the two major authorities was preserved by providing for them to continue to report directly and independently to the Minister.

The historical development of these institutional arrangements is indicated in Figure 4.

The restructuring in 1984 was part of the overall review process. The State Rivers and Water Supply Commission was reconstituted as the Rural Water Commission and some of its administrative and regulatory powers which it formerly exercised on behalf of the Minister were transferred to the Department, together with the relevant staff. The functions of the Department of Water Resources and the Rural Water Commission are set out in Table 3.

The Rural Water Commission has maintained its role as the State-wide operating agency. However, the new legislation includes more positive provisions for the transfer of functions to locally managed authorities, and these initiatives can be taken by the relevant community, rather than the commission.

The new legislation enhances the powers of the Minister to exercise more positive powers of control and direction, while at the same time providing scope for the Authorities in the water sector to exercise a high degree of managerial autonomy in a commercial and businesslike manner.

The management thrust is toward total cost recovery from all consumers served by the Authorities in the Water Sector, with provisions for the government to equalize the cost of services to consumers across the State, by a combination of measures including capital grants towards the initial cost of works, subsidized interest rates on Authority borrowings, or direct revenue grants.

Figure 4. History of institutional arrangements for management of water in the State of Victoria, Australia.

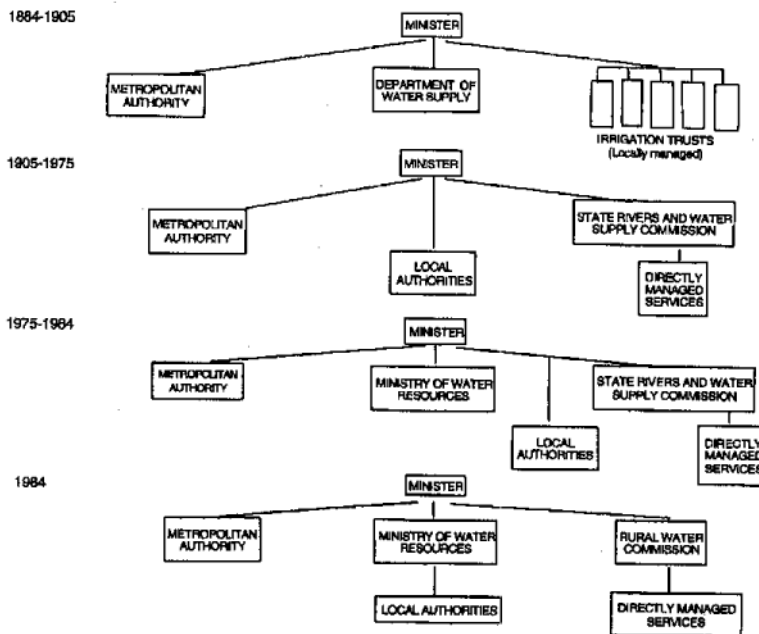



*Table 3. Functions of the central water agencies in the State of Victoria, Australia.*

### **Department of Water Resources**

- To provide advice to the Minister on:
  - a. the management, development and use of the water resource of the State, and
  - b. the provision of water services to the people of Victoria;
- To review and develop policy options, plans and programs for the water sector in consultation with operating agencies where appropriate, to coordinate policy development within the industry, and to advise the Minister on industry plans, programs and institutional arrangements;
- To ensure the development of a comprehensive database for the Victorian water sector relating to water resources and water-related matters, and financial, physical, and manpower resources, and to analyze and monitor the database in the development of policies, plans and programs;
- To develop guidelines and planning parameters, to assist operating agencies in the water industry to develop plans and programs and to provide advice to agencies;
- To analyze financial programs and budgets prepared by various operating agencies in the water industry, to identify associated policy issues and to provide advice to the Minister on all aspects of such programs and budgets prior to their consideration and approval by the Government;
- To monitor and review the performance of operating agencies against approved budgets, programs and objectives, and to assist the Minister in evaluating and reporting on industry performance;
- To provide management and technical support and to disseminate information to the various bodies in the water industry;
- To develop public education programs to promote community awareness of the need for more efficient and effective management of the State's water resources,

### **Rural Water Commission**

- To provide water and water-related services for irrigation, domestic and stock uses and for commercial, industrial, recreational, environmental and other beneficial uses in irrigation and other rural areas throughout Victoria;
- To design, construct, operate and maintain the necessary infrastructure to enable the delivery of services;
- To allocate and sell water and, where necessary, purchase water, and implement pricing and demand management policies;
- To undertake resource assessment, and investigations pursuant to the effective and efficient operation and maintenance of rural water services.

## GOVERNANCE: TRENDS TO AUTONOMY, PRIVATIZATION

In Victoria, 75 percent of the irrigated area is located within large irrigation districts of 12,000 to 400,000 hectares. The remaining 25 percent lies in the private sector, either as private individual farms, or cooperatives or companies.

Traditionally, the water bodies have been legally constituted as public-sector bodies, but with a high degree of local management responsibility:

- In urban systems, the responsibility is total, subject to compliance with legislation.
- In irrigation, farmer involvement has been advisory with increasing responsibility in policy development.
- The bodies have been "corporatized," i.e., they have been set up as commercial business undertakings (see later comments under *Financial Framework*).

One State Government has initiated moves to privatize large irrigation distribution systems (New South Wales). There is a consensus elsewhere that the complexities of full privatization have not been recognized, and it is doubtful whether the process will go further than "corporatization" in other States.

In Australia, farm sizes are generally large, and farmers are responsible for the management of the distribution system (tertiary system) within their lands.

## LEGAL FRAMEWORK — WATER RIGHTS, LAND TENURE

Almost all irrigation land is privately owned, or under lease from the State.

The rights to the control and use of water are vested in the State.

Individual rights to water are regulated by issue of rights and entitlements on a volumetric basis from the Central Agency, acting on behalf of the State.

In irrigation districts, there are no user association laws as such, but legally constituted irrigation districts have legal assignments of water, within which the rights of individual farmers are specified (see also comments under *Farmers' Role and Status*).

Processes for allocation of water have undergone change in recent times. Prior to 1984, water was allocated by administrative actions of the Central Water Agency. After 1986, this administrative system was replaced by a more market-oriented system in which rights are transferable. The changeover from one system to the other was managed in the transitional period, 1984–86.

Details of the procedures in these three periods are given in the following paragraphs.

### The Administrative System, before 1984

- Headworks Development Projects were approved by the Government following an open public inquiry by an all-party Parliamentary Public Works Committee.
- Subsequent water allocations were then issued in accordance with the approved project conditions and uses.

- For allocations to Irrigation Districts, legal assignment of the total District Allocation was made by legislation and recorded by the Central Agency.
- Individual entitlements to landholders with lands within the district were issued up to the total volume of the authorized District Assignment, with allowance made for district distribution losses.
- These individual entitlements were recorded in a Register of Lands for the District, which is a public document.
- The authorized District Assignments formed the basis of storage operation release rules.

### **Transition Period 1984–86**

- The system of "free" allocations of water by administrative actions by the Central Agency was scheduled to be replaced by a more market-oriented system.
- The State Government instituted a process of hearings by a specially constituted "Anomalies Tribunal" by which persons aggrieved by previous administrative decisions which affected their water allocations could have those decisions reviewed. Where judged necessary by the Tribunal, corrective allocations were made.

### **Allocation and Transferability Process, after 1986**

- Existing District Assignments were redesignated as Bulk Water Licenses
- New Bulk Water Licenses would be issued subject to the outcome of a public inquiry process established by the Minister at which time the effects of the proposed new allocation would be canvassed.
- **Bulk Water Licenses** would be subject to bulk water charges (see comments under *Financial Framework*).
- Bulk Water Licenses can be transferred between holders by negotiation or private treaty.
- Water rights to individuals within Districts can be obtained by either:
  - a. Purchase of new allocations within the District Bulk Water License (if available), or
  - b. By purchase and transfer from another person within the District.

### **Processes for Transfers**

- i. The intending buyer seeks a permit to purchase which is issued by the District Management agency after considering:
  - a. the effect on existing canal distribution capacity and service to other water users, and

- b. potential environmental effects (waterlogging and salinity hazards).
- ii. On the issue of the permit, the buyer seeks purchase by private treaty — permits are restricted to a single supply system.
- iii. Transfers are registered in the management agency records.
  - The management agency is empowered to buy water rights from individuals, and may do so for system efficiency purposes, e.g., buy out residual small allocations on high cost canal systems.

## Farmers' Role and Status

Farmers own land individually.

Within each legally constituted irrigation district, there is an Advisory Board of farmers, elected from the body of irrigators, in accordance with bylaws in the Water Act.

The role of Advisory Boards has evolved over the years from advising the management authority on day-to-day operational matters to greater involvement in policy development and development of "Level of Service" specifications.

In 1992, in Victoria, Management Boards have been constituted with responsibility for overall policy development and management of the distribution system assets.

The Central Agency retains responsibility for management of the headworks (reservoirs, river diversion works).

## Financial Framework

Traditionally, recipients of water and drainage services have been expected to pay full cost of service provision as far as operation and maintenance are concerned. This is levied directly by charges of fees on the property owner.

The legislation **has** provided for Government subsidies for capital and renewal costs in some cases of economically weak and isolated communities, where adverse economies of scale exist.

Current Government policies are moving toward full cost recovery in irrigation. This is acknowledged to be a long-term process.

In irrigation, the legislation provides for farmers to pay full cost, including capital cost of distribution systems. However, government intervention in the past **has** reduced the percentage of cost recovery in various districts, depending on economic viability, to between 50 percent and 80 percent.

Traditionally, the capital cost of headworks (dams and regulators) has been borne by the State, with farmers paying a proportion of operation and maintenance costs.

Most Australian Governments are now adopting policies as follows:

- Distribution costs: Irrigators will pay 100 percent of operation, maintenance and renewals costs (i.e., maintenance in perpetuity)
- Headworks costs: Will be recovered from **all** water users through Bulk Water License fees. Irrigators will pay a negotiated lower fee in the short term

The distribution cost and headworks cost will be levied on a volumetric basis.

In irrigation districts, water charges based on costs of operation and maintenance comprise two elements:

- A fixed compulsory charge related to water rights allocated
- An additional charge related to usage above water rights (if available)

The fixed charge, if not paid, remains a charge on the land, and may be recovered by the authority by forced sale of the land.

## RIVER BASIN MANAGEMENT INSTITUTIONS AND INTERGOVERNMENT COOPERATION

As described earlier, the responsibilities for land and water management remain with State Governments, the land and water in fact being "owned" by the States.

Each of the States of Queensland, New South Wales, Victoria and South Australia has significant areas located within the catchment of Australia's most significant river basin, the Murray-Darling Basin, whose location is shown in Figure 5.

The need for formal institutional arrangements at the basin level became obvious during the period of early development of water resources within the upper States, when these individual developments began to affect existing and potential developments in the lower State.

These early concerns led to the establishment of the River Murray Commission in 1915 to coordinate the planning and development of the resources of the basin, by works along the main stem of the river to facilitate development within each State. The second institution at the basin level was established in 1949 when the Snowy Mountains Hydroelectric Authority was created.

The essential features of these institutions is that they were established following agreements between the contracting Governments. These agreements followed comprehensive technical investigations in which the relevant Governments were represented. These investigations identified a set of potential development schemes with indicative benefits and costs, and the relative share of costs and benefits which would accrue to each of the parties to the agreement. In each case, the institution was established to implement and subsequently manage an agreed set of project developments. The locations of major irrigated areas are shown in Figure 6.

In the case of the Murray River, capital costs of projects would be shared equally by the Commonwealth and the 3 States involved, and the operating costs would be borne in equal shares by the 3 States. The water resources of the basin were to be shared on the basis that the downstream State (South Australia) receive a fixed annual entitlement in specified monthly allotments and the upper two States share equally in the remaining resources controlled by the works of the River Murray Commission, with the right to utilize individual State tributary flows.

By these arrangements, the obligation to recover operation and maintenance costs remained with the benefiting States.

In the case of the Snowy Mountains there are two institutions, the Snowy Mountains Hydroelectric Authority, responsible for carrying out the construction, operation and maintenance of the works, and the Snowy Mountains Council, which directs and controls the operation and maintenance of the works. The total costs of the works are met by electricity sold to the Electricity Commissions of New South Wales, Victoria and the Australian Capital Territory.

Given below are a number of features from the Australian experience which may have relevance in the examination of institutional arrangements for sustainable management of water resources where multiple political jurisdictions are involved.

- a. Any agreement will generally be limited to the extent of the individual rights and privileges each jurisdiction is prepared to cede in order to achieve the common good.

- b. The institutional arrangements established to administer such an agreement must provide clear-cut and uninhibited processes for ensuring that each party is able to access information relevant to its own political, economic and environmental interests. These arrangements should include measures to reach agreement at the technical, operational management and policy levels.
- c. The charter under which the institution operates should have sufficient depth and flexibility to address **all** relevant matters. Each party should be represented and provided with expertise of each relevant discipline.
- d. There must be clear identification of the rights and obligations of each party, but the institution should possess sufficient executive powers to act independently of individual parties for the common good.

*Figure 5. Location of the Murray-Darling River Basin in relation to state boundaries.*

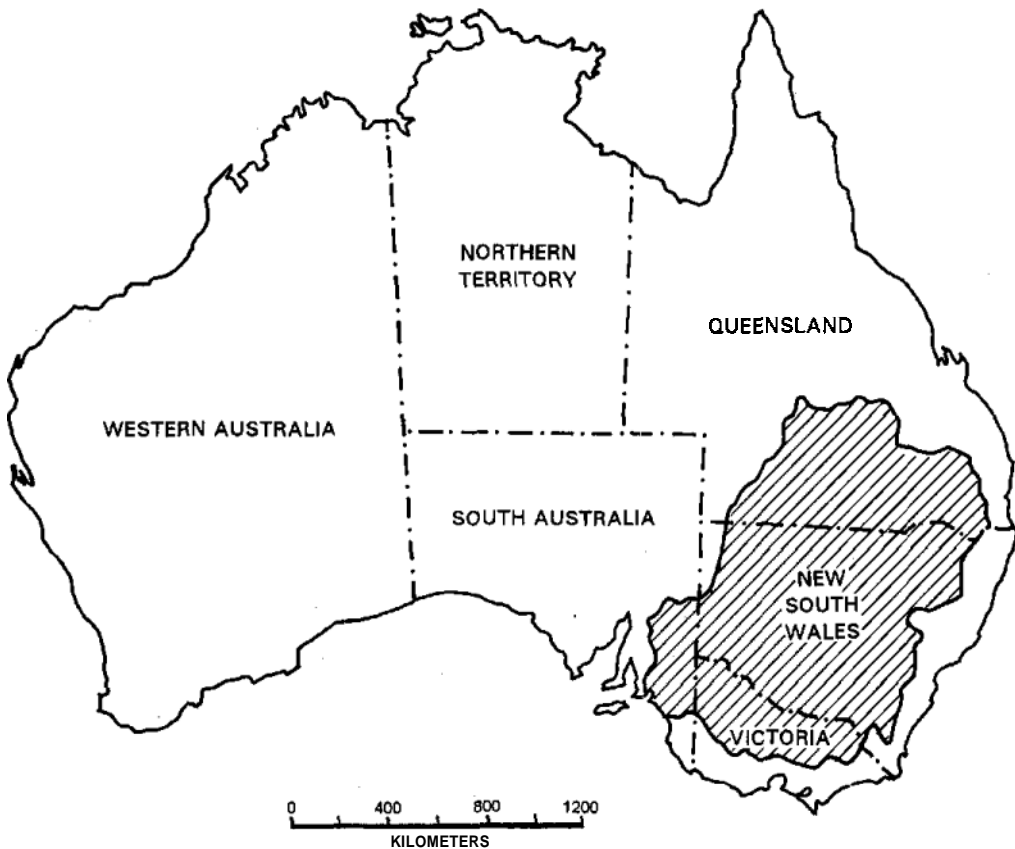

% Basin in State		% State in Basin	
New South Wales	57	New South Wales	83
Victoria	12	Victoria	50
South Australia	6	South Australia	7
Queensland	25	Queensland	17

Figure 6. Major irrigation areas in the Murray-Darling Basin.

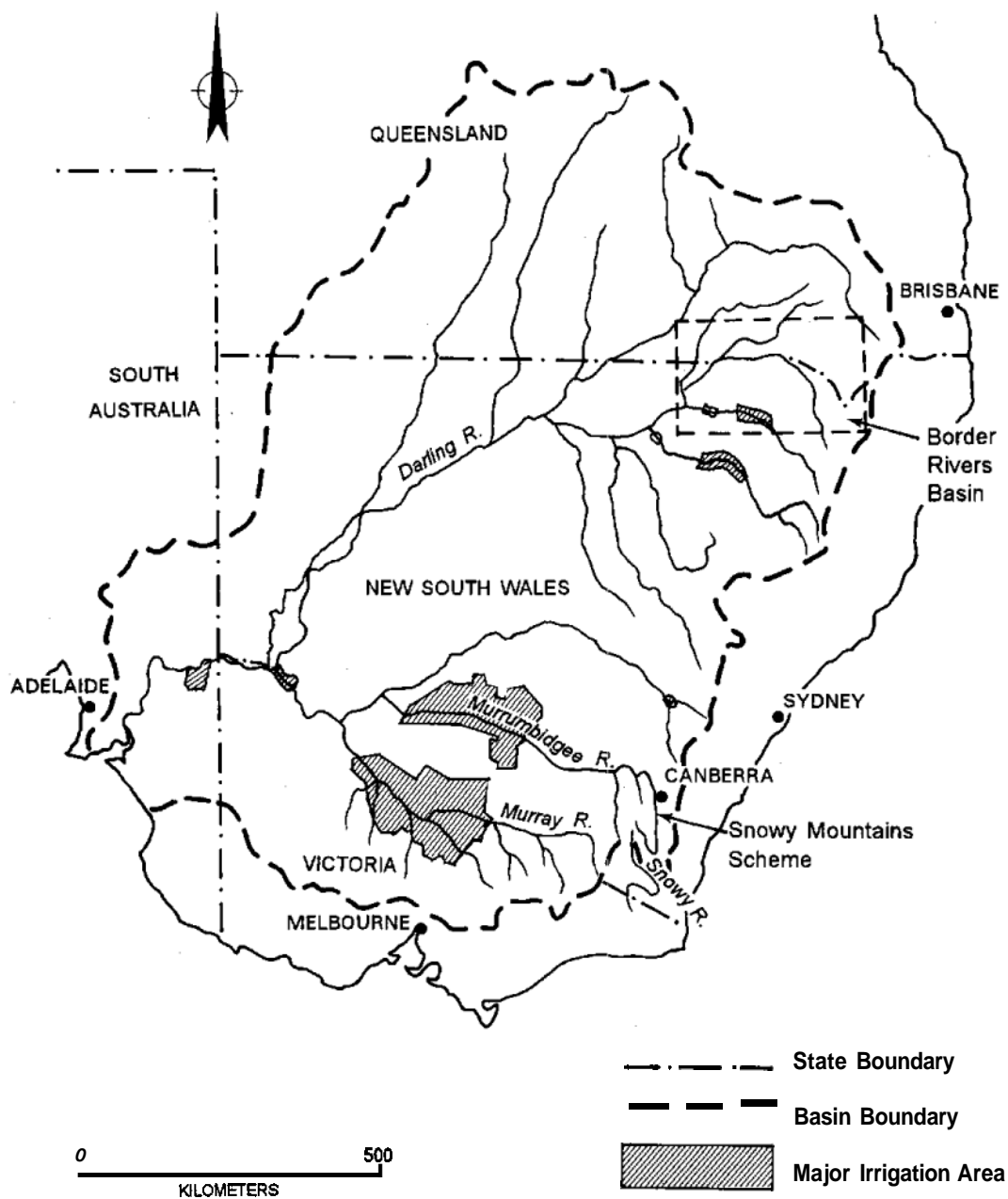

## **INSTITUTIONAL SERVICES**



# Service Analyses in Soil and Water Management Associations Taking the Nienburg/Weser Association as an Example<sup>4</sup>

*W. Huppert<sup>5</sup> and K. Urban<sup>6</sup>*

## INTRODUCTION

WATER AND SOIL associations are service organizations. Their remit, in line with their statutes, is to provide services for their members and the general public, including the development and maintenance of waterways, the construction and maintenance of structures in and along waterways, and the operation and maintenance of irrigation and drainage installations. To provide these services, which are the very purpose of the association, it has to enter into a complex exchange of services with other organizations and providers or beneficiaries of services; coordination services, information services, negotiation services, representation services, etc., are all part of the various "secondary" service provided by or for water and soil associations within a network of relevant partners.

In view of the efforts to cut through the bureaucracy of the water and soil associations and to boost efficiency it would seem appropriate to analyze and make transparent this tapestry of various services and service relations into which the association is woven.

The Deutsche Gesellschaft für Technische Zusammenarbeit (GTZ) GmbH, is currently developing a range of instruments which will make it possible to clarify and analyze complex service networks of this sort. Within the scope of "interact," an in-house research and development project, the GTZ is developing and testing concepts and instruments which should enable the identification and analysis of services within the overall framework of complex projects which embrace many actors.

One of the instruments developed by "interact" has been termed the "service interaction analysis (SIA)," which makes it possible to systematically record the intricate network of services and inputs provided by and for the organizations involved in any given project. At the same time, the service interaction analysis can be used to analyze problems arising between organizations or between different units belonging to the same organization in this context. taking into account the special nature of services.

The service interaction analysis has been tested in various GTZ projects, including projects in Haiti, Bolivia and Tanzania. In response to a request by the Director of the Bremen, Lower-Saxony and Saxony-Anhalt Water Association Federation, this instrument has now been tested for the first time outside the confines of development cooperation, taking the example of one individual water and soil association, the Nienburg/Weser Maintenance Association. The test

---

4 A German version of this paper is published in "Zeitschrift für Bewässerungswirtschaft," No. 2/93, p. 175-190.

5 Senior Planning Officer. German Agency for Technical Cooperation (GTZ), Escborn, Germany.

6 Independent Consultant. Wiesbaden, Germany.

took the form of a workshop which was held on the 17th and 18th of August in Nienburg/Weser, attended by the directors of several of the individual associations which go to make up the Bremen, Lower-Saxony and Saxony-Anhalt Water Association Federation. The workshop, and the experience gained there are presented in this article.'

## THE OBJECTIVES AND PROGRAM OF THE WORKSHOP

The workshop aimed to record and analyze the services provided by and for the Nienburg Maintenance Association.

It was agreed in advance that the service interaction analysis would be tested, taking one of the 1,100 or so individual associations that make up the Bremen, Lower-Saxony and Saxony-Anhalt Water Association Federation as an example. The Nienburg Association was selected because both the services it provides and the problems arising in this context are considered fully representative of the individual associations within the federation. The 2-day SIA workshop embraced the following 7 fundamental steps, which are presented in detail under the heading *The Course of the Service Interaction Analysis*:

1. Presentation of the tapestry of relations
2. Definition of the range of services offered by the Nienburg Association
3. Definition of the range of services provided for the Nienburg Association
4. Analysis of strengths and weaknesses
5. Problem analyses 1 and 2
6. Identification of the Association's internal service program
7. Problem analysis 3

In point of fact two separate service interaction analyses were conducted: first, the analysis of the services linking the Nienburg Association to its external environment (steps 1 to 5); and second, the Association's internal services (steps 6 and 7).

At the end of the workshop, participants gave their assessment of the service interaction analysis and further action was discussed and planned.

## THE COURSE OF THE SERVICE INTERACTION ANALYSIS

This section will look at the most important steps involved in service interaction analysis, as conducted at the workshop. The function of each step will be described briefly, followed by an account of the Nienburg experience.

---

7 The authors would like to thank all the workshop participants for taking part in the intensive discussions over two days, and would like to single out Mr. Mücke from the Nienburg an der Weser Association for special recognition and thanks for ensuring that the workshop ran so smoothly. The authors' special thanks also go to Baron von Seinaecker, who was responsible for logistics and helped prepare the subject matter subsequently covered by the workshop.

## Step 1. Presentation of the Tapestry of Relations

The first step aims to render transparent the complex tapestry of relations that exists between organizations working within a service network. To this end, the organizations involved are presented graphically in the form of a so-called "relations map," which is intended to give an overview of the main participants and the interfaces involved, without recording every individual interaction precisely. The graphic presentation is used as a guideline in the subsequent analysis, particularly the problem analysis.

It is assumed that not only "goods and services" are exchanged at the interface between two organizations, but that other exchanges and communications take place. The following relations are taken into account within the scope of the service interaction analysis:

- Exchange relations of goods and services
- Legal relations
- Information relations.
- Interpersonal relations.
- Power and dominance relations.

At the workshop described here, the service interacting analysis focused on recording and analyzing service relations between organizations involved in the network.

The graphic presentation of the organizations involved in the work of the Nienburg Association was drawn up in conjunction with all workshop participants in a plenary session. On the basis of a hypothetical maintenance measure, one of the typical tasks of the Association, a list was drawn up of all the organizations with which the Association would come into contact within this context. It emerged that, in sharp contrast to experience already gained with this instrument in GTZ irrigation projects, the Nienburg Association has a large number of more or less isolated "one-off" relations to various organizations within the scope of its work. The various operations to be performed do not automatically lead on from one another as is the case in a number of consultancy projects in the field of "Technical Cooperation." In these projects, organization A provides consultancy services, for instance (GTZ input) to organization B (irrigation project in partner country), which in its turn advises or supports organization C (water users' association), which goes on to provide services to organization or group D (water users, members of a village community). The graphic presentation of these service interactions generally takes the form of a chain, whereas the presentation of the Nienburg model emerged as a sort of "solar system," with several organizations orbiting around the core organization, the Nienburg Association. The core organization is directly involved in all major operations. negotiating directly with planning authorities to obtain the necessary permits, contacting a planning office, organizing the construction work, etc. From the point of view of the Nienburg Association, the web of relations is then extremely dense (see Table 4).

## Step 2. Definition of the Range of Services Provided by the Nienburg Association

One of the central activities of the service interaction analysis is to draw up an overview of the entire range of services provided by the organization or organizations under review. This illustrates the full breadth of the services provided by the organization for various bodies and/or individuals. To this end a list is drawn up of all the individual services provided by the organization, along with the beneficiaries of these services. The list is then broken down and

categorized by type of service and beneficiary. This tends to reveal a number of services which would otherwise often be glossed over or forgotten because of their intangible nature. These can be coordination inputs (liaising, clarifying legal issues) and information services (issuing circulars, organizing information events), which are frequently time-consuming and complex, although they are often not accorded the consideration they deserve in planning work, in contrast to the "real" or "hard" services (such as construction and repair work in the case of a water and soil association). The range of services also reveals the entire spectrum of beneficiaries of services who have relations to a certain organization.

*Table 4. Network of relations of the Nienburg/Weser Maintenance Association.*

This is a list of organizations and groups with whom the Maintenance Association has working relationships in order to accomplish its purposes. Items marked \* are not directly relevant to maintenance activities.

1. Nienburg District Association (Umbrella organization)
2. Lower District Water Authority
3. Lower District Conservation Authority
4. Upper District Water Authority
5. Upper District Conservation Authority
- \*6. Independent Conservation Associations
- \*7. "29 Associations
- \*8. Farmers' Association
9. Members
10. Obstructors
11. Contractors
12. Own engineering planning office
13. External engineering offices
14. Consultants
15. Other interested parties
16. Agriculture authorities
17. Water management authorities
18. Conservation authorities
19. Banks
20. Standards authority
21. Subsidizing agencies
22. Courts of law
23. Public prosecutors
24. Neighborhood associations
25. Fishery organizations
26. Holders of water rights
27. Communities
- \*28. Town and country planning authorities
- \*29. Raw material extraction companies
30. Forestry authorities
31. National and regional bodies
32. Social environment

In the present case, it rapidly became clear to all participants that attention tended to focus on the central activities (active maintenance measures, i.e., clearance, maintenance, repair work) of the Nienburg Association when work was organized. The Association, however, performs a large number of other services, which are not generally as systematically planned as the so-called "active maintenance measures." These include, in particular, the extremely time-consuming and often difficult information and coordination work of the Association (see Table 5).

**Table 5. Range of services provided by Maintenance Associations in general and the Nienburg Association in particular.**

Services provided for	Members	Nonmembers		
Type of Service		Permit-issuing authorities	Other institutions	Social environment
1. Active maintenance activities	* Clearance * Repair * Maintenance			<b>Ecology</b> (clearance, repair, maintenance)
2. Internal services	* Planning/engineering services * Internal administration services * Administration of membership fees * Updating records of land use			
3. Coordination services	* <b>Internal</b> coordination	* <b>External</b> coordination (obtaining necessary permits)	* External coordination (liaising and coordinating with other bodies) * Clarifying legal issues and cases	
4. Information services	* <b>Information</b> events		* Issuing circulars * Information events * <b>Trade fairs/exhibitions</b>	* <b>Trade fairs/exhibitions</b> * <b>Information</b>

### Step 3. Definition of the Range of Services Provided to the Nienburg Association

The definition of all the services provided for the organization under review (with a list of the providers of these services) is intended to render transparent the requirements made of the organization as a result of its accepting these services, in addition to recording these services systematically.

In the case of the Nienburg Association the definition of services provided to the Association (Table 6) revealed that the Association is the beneficiary of a large number of services provided by various organizations, which demands major inputs on the part of the organization for logistics and to shape the relevant relations, although the true extent of these had never before been fully appreciated.

#### Step 4. Analysis of Strengths and Weaknesses

The analysis of the strengths and weaknesses of an organization was included in the service interaction analysis so as to enable the identification of problems and difficult operations within the range of services.

To assess the quality of the services provided by the Nienburg Association, workshop participants assessed the services listed in step 2 on a scale from 1 to 5, from very weak to very strong. Participants based their evaluation on both the effectiveness and the efficiency of the services provided (Figure 7).

All in all, the problem analysis made the decision makers more aware of the importance of the so-called "software" sector (better legal training, improved communication with external organizations and marketing) for the work of the Association.

On the whole, participants gave the Association higher marks for the work it performs in the "traditional" field of clearance, repair, engineering services, etc., than for the work it performs in the software sectors (coordination, information)—a result which may be of particular interest to the managers of the Association.

On the basis of the analysis of strengths and weaknesses, two particular problem areas were selected for closer examination.

#### Step 5. Problem Analyses 1 and 2

The problem analysis conducted within a service interaction analysis looks in more detail at those services which workshop participants have classed as problem areas. The special nature of services, i.e., that they can, as a rule, only be provided with the collaboration of the client, must be taken into account. Interaction with the client is particularly important in the case of interpersonal services, such as consultancy. This means that the problems of providing services must be seen not only from the viewpoint of the provider, but also from the side of the beneficiary and at the interface of these two sides, where the interaction per se takes place. Thus the problem analysis looks at the problems identified at three separate levels: i) problems involved in providing services, ii) problems involved in accepting the services, and iii) problems involved at the interface.

In the present case, two areas were classed by participants as being particularly difficult: i) services provided by the Nienburg Association to the permit-issuing authorities in conjunction with approval procedures (Table 7), and ii) services provided by the Association vis à vis other institutions in the fields of external coordination, liaison and coordination with other legal entities (Table 8).

Table 6. Range of services provided to Maintenance Associations in general and the Nienburg/Weser Association in particular.

* 2) 1) 3) service	Environment												
	MEMBERS association	USERS association	Umbrella association	Autonomous enterprises	Independent conservation associations	Farmers' Association	"Obstructors"	Consultant/ Authorities	Banks	Neighbor Associations	Holders of water rights	Communities	Regional and national authorities (rail-ways, post office, etc.)
1. Economic inputs	Fees and other financial services	-Engineering services (technical/economical/ecological) -Force account work	Consultancy services*	Subsidies	-Engineering services -Maintenance services	-Consultancy services*	Difficulty in contributions	Consultancy	Financial services		Financial services		
1.1. Services in the strict sense													
1.2. Organizational services	Information services	-Information services -PR services			Information services	Information services	Information services	Information services					
2. Coordination services	Obligation to tolerate*	Administrative services		-Authorizations -Permits -Support for obligatory measures									
3. Representation services		Representation of interests	Representation of interests										

\* Denotes problem areas.

Figure 7. Services provided by the Nienburg/Weser Maintenance Association: Analysis of strengths and weaknesses.

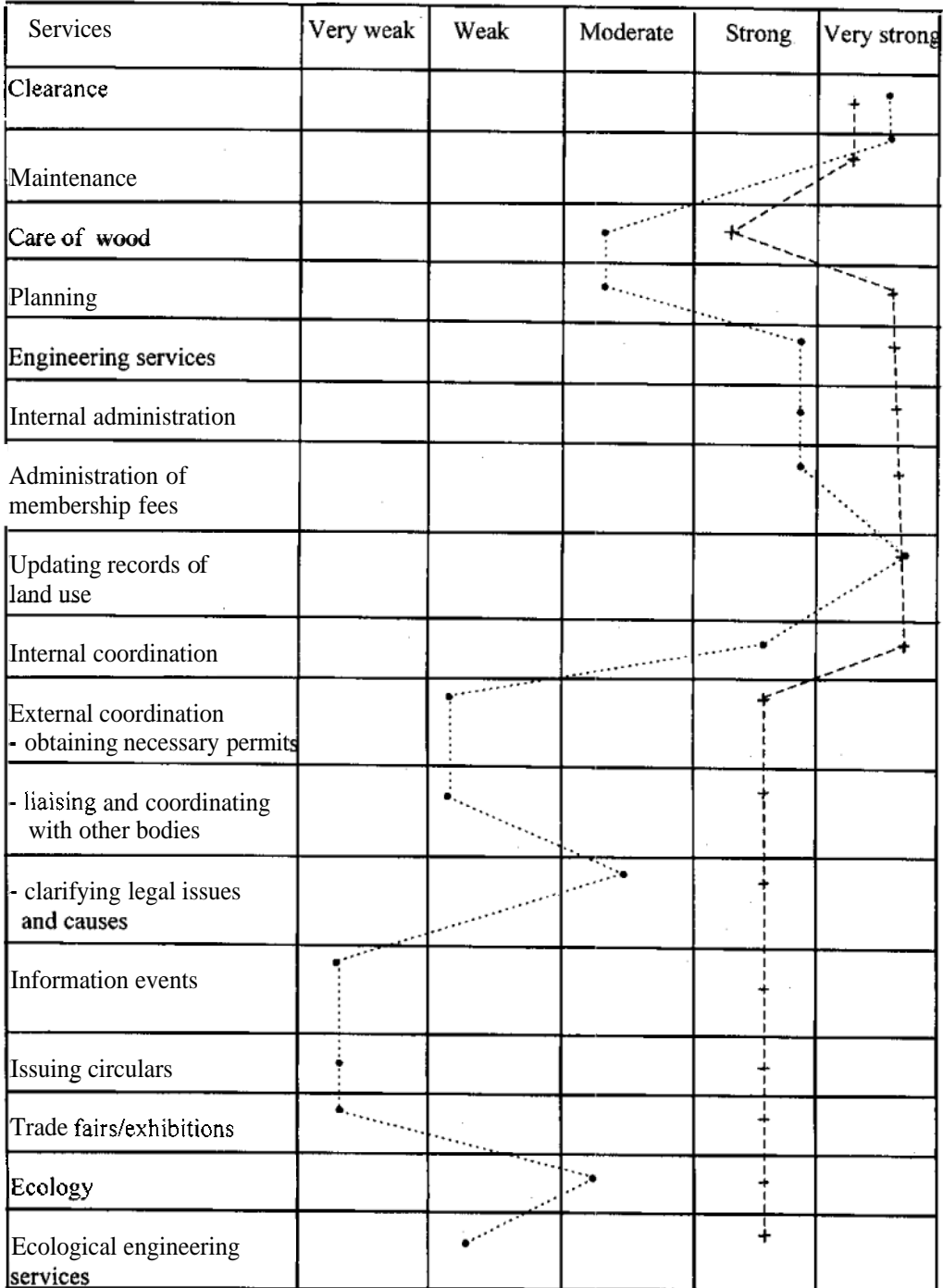

Note: • Associations in general.  
 + Nienburg Association.



**Table 7. Problem analysis 1: Services provided by maintenance associations (in general) to permit-issuing authorities—approval procedures.**

Problems at service provider level	Problems at service recipient level	Problems at the interface
* Inadequate ecological knowledge	* Dubious interpretation of legal terms	* Inexact definition of legal terms
* Lack of resolve when pushing through the interests of the Association on legal issues	* Exerting party political influence on the (interpretation of) legal terms	* Inappropriate ideas on ensuring future cooperation/ compromises
	* Political pressure exerted by conservation associations	* Need to improve communication
	* Lengthy and complex decision-making processes	
3. Improve communication with the conservation authorities and associations (step up and improve public relations work, hold information events and run discussion groups).		
4. Improve communication in the political sector (chance to act as consultants for committees).		

Problems at service provider level	Problems at service recipient level	Problems at the interface
* Inadequate knowledge of cable protection regulations	* Different positions and interpretations of legislation within conservation associations	* No clear division of responsibility
* Failure to take account of regulations governing utilities	* Cooperation pursuant to "56" Conservation Act does not work	* Same communication problems with representatives of the conservation associations
* Cooperation pursuant to "56 Conservation Act does not work	* Overstretched authorities (deadlines)	
<b>Proposed Solutions/Recommendations</b>		
1. Transparent directives.		
2. Establish a basis for discussion of ecological matters (impart knowledge and involve ecological experts).		
3. Improve communication with conservation associations (see problem analysis 1).		

The problem analysis allowed participants to identify weaknesses on the side of the provider of services of which they had not hitherto been so poignantly aware. It emerged, for example, that the inadequate ecological expertise of the Association's representatives worked against its efforts to obtain relevant permits.

It was also possible to develop proposals to tackle the various problems with a view to improving services, tackling the problem of operation directly (the solution proposed for the problem outlined above was to organize ecological training for the Association's staff, or harness external expertise in the person of consultants). The problem analysis also allowed participants to distinguish between problems they could influence and those they could not influence (e.g., long and complex decision-making processes on the part of the recipients of services or "political pressure from conservation groups").

All in all, the problem analysis made the decision makers more aware of the importance of the so-called "software" sector (better legal training, improved communication with external organizations and marketing) for the work of the Association.

### **Step 6. Identification of the Association's Internal Service Program**

Before the workshop, the Director of the Bremen, Lower-Saxony and Saxony-Anhalt Water Association Federation had pointed out that problems arising between the "voluntary" and the "official" sectors of the water associations not infrequently impede the work of these bodies. For this reason, it was decided to define the internal service program of the Association in addition to the range of services provided to external clients (Table 9). The internal service program of the Association comprises the services provided by the various units within the organization (1. members/committee, 2. board, 3. office) to both other units and bodies outside the Association.

In the case of the Nienburg Association, this procedure made it possible to localize exactly the main problems between the voluntary and the official sectors within the scope for internal services. The main problem area proved to be the preparatory work performed by the office for board decisions. A special problem analysis was then conducted for this field.

### **Step 7. Problem Analysis 3**

In general terms, problem analysis 3 is closely akin to analyses 1 and 2, as described under *Problem Analyses 1 and 2*. The problems are reviewed at three levels: i) problems involved in providing services, ii) problems involved in accepting the service, and iii) problems involved at the interface.

The exact review of the various levels of provision of services focused on "preparatory work for board decisions," which allowed participants to examine the problem from every angle. It emerged that the voluntary representatives felt that they were being bypassed by the secretariat and overstretched by their "superior knowledge" and the "completed staff work" for board decisions (Table 10). By highlighting this more "psychological dimension," it was possible to perceive the true importance of the problem, which was not generally discussed openly and frankly, and to develop potential solutions, which could defuse the conflict (e.g., modifications to the scheduling and involving voluntary members at an earlier stage, etc.).

## **CONCLUSION AND COMMENTARY**

At the workshop described here, the service interaction analysis was tested, taking one association as an example. The objective of the workshop was to record and analyze the services provided by and for the Nienburg/Weser Maintenance Association.

Table 9. Range of services within Maintenance Associations.

	Members/committee	Board	Office	Association (general)	Environment
Members/committee		Monitoring Issuing directives Determining the economic plan and the fee structure Discharge	Support for the director	Elections, personnel decisions (in the voluntary sector) Approving the statutes,	Information* Making decisions of the association transparent*
Board	Reporting* Information* Drafting the statutes Making decisions of the association transparent, publicity work for the cause of the association*		Drawing up the code of procedure	Representing the legal position of the association vis a vis the outside world Association decisions Collecting fees (formally)* Hiring staff Monitoring the office Making the decisions of the association transparent	Information inputs* Representing the association in legal issues Making the decisions of the association transparent*
Office		Preparatory work for board decisions* Executing the decision of the board Consultancy Information inputs		Executing all decisions of the board* Administration inputs PR work* Observation of developments in the environment* Operational inputs	PR work* Information inputs

\*Denotes problem areas.

*Table 10. Problem analysis 3: Services provided by the office to the Board— Preparation of Board decisions*

Problems at service provide level	Problems at service, recipient level	Problems at the interface
* Time lost as a result of coordination problems	* Overstretched (deadlines)	* Coordination of deadlines
* Too much time spent recording and presenting legal and other directives in a transparent way; too little time for other work	* Increasingly time-consuming work and increasing responsibility under civil and criminal law	* Increasing complexity of tasks as a result of legal and other directives
* In some cases inadequate training in view of the increasing complexity of the work	* Reduced decision-making authority because of excessive preparatory work for board decisions	* Occasionally, activities of volunteers are not discussed with full-time staff (and vice versa)
* Partially incorrect understanding of the role of the service provider	* Possible detrimental effect of conflicts of interest on decisions	* Special importance of good personal relations
* At times, personal topic-related preferences have too much influence	* Partially incorrect understanding of the role of the service provider	* Power politics sometimes stand in the way of a free flow of information * Sometimes, lack of clarity and acceptance of different roles

It proved possible to spotlight precisely those (difficult) aspects of the provision of services, which are frequently neglected because of their intangible nature, e.g., consultancy, coordination and PR work. The workshop made it clear that these areas must be subjected to an analysis and planning procedure that is at least as detailed as the classical, or "hardware" sectors (in this case clearance, repair, maintenance). The service interaction analysis also allowed participants to discuss possible solutions for these "sensitive" areas, immediately after the problem analyses, which tackled not only the operations involved, but also the service recipient level and the interaction, or interface of the two sides.

The workshop demonstrated that the service interaction analysis is a valuable instrument to launch a discussion of services provided and the problems arising in this context. The instrument is also a good way to start to analyze important inner organizational problems systematically. Finally, the SIA allows both "internal" and "external" participants—where external participants attend the workshop—to clarify their roles within the overall network of relations.

## Bibliography

- Huppert, W. 1989. Situation conformity and service orientation in irrigation management, GTZ Special Publication No. **242**, Eschborn.
- Huppen, W. **1992**. Service interaction analysis - towards identification and analysis of service relations in irrigation systems, unpublished manuscript.
- Huppert, W. and Urban, K. **1992**. Report on the Service Interaction Analysis Workshop held at the District Association for Water Management in Nienburg/Weser, Germany (German language), interact project, Deutsche Gesellschaft für Technische Zusammenarbeit (GTZ) GmbH.

# Water Law and the Development Process

*D.J. Constable and B.E. Foley*<sup>8</sup>

## INTRODUCTION

THESE NOTES HAVE been written from the viewpoint of a practical irrigation engineering manager and not that of a qualified lawyer. The irrigation manager **must** have a very good knowledge of both the general legal system of the country and the particular provisions relating to management of water resources **as** part of the irrigation system. These provisions **are** generally referred to **as** "Water Law."

Irrigation agencies which are established directly **as** government authorities, or as some form of semigovernment board, usually have their basic charter, powers, duties and functions specified in the legislation which establishes them. Furthermore, many actions **of** the authority are spelt out in **laws** and government directives applying to all government bodies in the particular country, e.g.:

- Treasury/finance rules and procedures
- Public employment rules
- Contract procedures
- Land purchase/leasing arrangements

There is usually a need for additional and specific Water Laws to be enacted because in most situations the customary or "common law" of the land, and government regulations applying generally to government departments and agencies, **are not** adequate to cater for the complex physical and climatic conditions under which large-scale irrigation schemes might operate.

The Water Law must be developed in the context of the physical, economic and social circumstances and governmental arrangements of the particular country. Water laws applicable in one country may be studied **as** a useful guide but **cannot** necessarily be adopted directly in another country.

---

<sup>8</sup> **This** paper was originally prepared in the former Centre for International Irrigation Training and Research (now incorporated in the International Development Technologies Centre), University of Melbourne, Parkville, Vic 3052, Australia where Professor D.J. Constable was formerly Director and Mr. B.E. Foley is a Senior Lecturer.

## GOVERNMENT INTERVENTION

### Development of Irrigated Agriculture

Significant modification of the hydrologic cycle is involved in large-scale development of irrigated agriculture, for example, in the capture, storage and conveyance of water from catchment lands and rivers to farmlands. This modification in most countries has required some alteration to customary use and entitlements to water. The development of farms under irrigated agriculture, involving change in land use, in many cases also involves modifications to the rights of traditional owners and/or occupiers of land, including resettlement.

The usual objectives of such development are first to provide for national self-sufficiency in food and fiber, and second to enhance the economic and social well-being of the population generally, and more specifically of communities at the local and regional levels.

The exercise of the necessary powers to facilitate the changes in land and water use, and the ability to mobilize the large amounts of capital necessary for such developments require, in most instances, the intervention of governments.

There are three elements to this intervention by governments:

- i. Legislative
- ii. Operational
- iii. Regulatory

The legislative function can only be performed by a government, and cannot be delegated. The operational and regulatory functions however are delegated, either to individual ministers, or officials, or to government agencies or parastatal organizations, or to private organizations (e.g., farmer organizations).

### The Legislative Function

The legislative function embraces the enactment of the relevant laws and decrees necessary to acquire and manage the relevant natural and financial resources, and the development of policies and regulations for their use and development, having regard to any relevant jurisdictions at national or provincial/state level. In some cases involving international rivers, legal agreements with other national governments may be involved.

Project authorization and project funding agreements are, in general, also functions of the Legislature or Government, together with legislation defining the powers, functions and responsibilities of the relevant institutions to carry out the delegated functions.

### The Operational Function

The operational function embraces the activities necessary for the development of irrigation projects such as:

- Data collection and dissemination, including
  - a. land availability and capability
  - b. water resources availability, surface and groundwater

- c. climatic characteristics;
- Planning
  - Design
- Construction
- Operation and maintenance
- Regulatory

**All** of these activities are delegated to government agencies to manage on behalf of the government. The government establishes the legislation and responsibilities of agencies, and the methods by which these agencies will have access to the necessary resources.

The agencies may either carry out these activities with directly employed staff, or under contractual arrangements with other agencies, private consultants or firms or individuals.

### **The Regulatory Function**

Regulatory functions include:

- Granting **of** rights to access and use land and/or water resources
- Monitoring extent of land and water use and resource status, e.g., water table levels, soil salinity
- Water quality and effluent discharge provisions
- Protection of individual rights and property

### **DEVELOPMENT AND MANAGEMENT PROCESSES: INSTITUTIONAL ARRANGEMENTS**

The development processes involve interactions between:

- a. Government
- b. Government agencies/institutions
- c. Citizens - as classes **of** users/beneficiaries, e.g., farmers, urban dwellers receiving water services as individual and/or as members of interest groups

### **Institutional Relationship**

The range of functions and disciplines involved in the development of irrigated agriculture invariably requires distribution of management responsibilities between a number of institutions, very often in separate ministries. These agencies/institutions should be developed in compatible units:



- Structured specifically to perform the delegated functions at the appropriate level of government
- Able to develop high levels of management and technical expertise
- Able to interact directly with user/beneficiary/interest groups

Collectively, they should be able to:

- Manage the overall delegated functions relative to land and water resources use, and the farm production system
- Cooperate effectively with other relevant resource management agencies
- Manage overall water resources, recognizing the unity of the natural hydrologic cycle

### **Need for Review of Water Law**

In many cases, the existing water laws and institutional arrangements were established to facilitate initial development. Because of changes in resource status, available technology and community expectations and perceptions, the laws and institutional arrangements may need review and modifications to meet the dynamic changes in the system, as development proceeds.

While irrigation is the major extractive user of water in most countries, water quality issues and competition from urban and industrial users will become more significant in the future. These factors, together with the need to achieve sustainability in resource use and agricultural production will focus more attention on specific policies and strategies for future management approaches in the water sector.

These strategy options from the water perspective need to be considered conjointly with the issues associated with sustainable land management and agricultural production systems.

### **Accountability of Institutions**

Institutions which have been established to carry out functions delegated to them by governments are "accountable," i.e., responsible to the government, for their overall efficiency and effectiveness. The government, itself, is ultimately accountable to the community-at-large for its overall performance, and has a number of mechanisms to provide a management overview of the performance of its delegated agencies, e.g., budgetary allocation and review process, annual reporting and financial audit process (see chart on p.95).

Water users and beneficiaries are accountable to the community as a whole for the way in which they utilize resources. and to fellow water users in the system to comply with the system rules.

The institution, however, is accountable to the government for the efficient and effective exercise of the functions delegated to it, and also to consumers for meeting the "level of service" obligations. In this context, an institution is very much "in the middle" in meeting its accountability requirements.

The following chart illustrates the relative accountabilities for an agency in the water sector, with responsibilities for provision of water for irrigation:

<b>Government</b>	<b>Institutions</b>	<b>Water users/Beneficiaries</b>
<b>Formulation of national objectives and policies</b>	<b>Formulation of institutional objectives and policies</b>	
<b>Legislation for: Allocation and control of resources: * Financial * Water</b>	<b>Control water allocation</b>	<b>Use water and land productively Obey laws</b>
<b>Delegation of functions * Powers and duties of institutions</b>	<b>Exercise delegated functions: Planning Design</b>	<b>Make demands</b>
<b>Protection of resource</b>	<b>Construction Operation Maintenance</b>	<b>Pay fees for services</b>

## **SPECIFIC ISSUES FOR IRRIGATION SYSTEMS**

The main areas in which specific water laws are required for an irrigation system are as follows:

Establishing rights for the authority to extract water in specific quantities and at various times subject to possible sharing arrangements with other authorities (e.g., municipal, other states and hydropower).

### **Rights and Powers of the Authority**

- a. Rights to investigate and build water supply works
- b. Rights to buy and sell land

- c. Rights to enter private land for purposes of operations and maintenance
- d. Provision to charge water service fees (where applicable)

### **Rights of Individual Farmers**

- a. Establishing rights of farmers, both as a group and as individuals, to use water for irrigation. These rights may be permanent, based on law or long-established traditions.
- b. Documentation of the level of service which the farmer can expect to receive and the detailed administrative arrangements governing all aspects of this service.

### **Offenses, Penalties**

There are various matters for which the authority may require specific enforcement and punitive powers, when cooperative methods do not achieve the desired result. These can include action to be taken in the event of:

- a. Damage to the authority's works
- h. Theft or illegal use of water, or other actions which affect the rights of other water users supplied by the system
- c. Failure to maintain farm channels in good condition
- d. Threatening or assaulting agencies' employees
- e. Failure to pay rates and charges (where applicable)

As a general rule the most effective standards of irrigation management and farmer compliance with the water authority are achieved where there is good communication and cooperation between authority and farmers. In these circumstances penalties are used as a last resort action although the authority should demonstrate that it can and will use them when cooperative methods do not work.

## **REPORTS OF THE WORKING GROUPS ON MAJOR INSTITUTIONAL FACTORS**

*On 4 November the workshop participants formed five working groups, each of which debated one of the five leading factors in the institutional framework. The groups were asked to address certain specific questions which had arisen in the preceding discussions. They were asked to develop generic, rather than country-specific, responses to these issues, and to consider "ideal" or long-term visions of optimal arrangements, without being constrained by their existing circumstances. The reports of these five working groups are summarized below.*

## Working Group I: Organizations

The specific questions put to this group were:

- What would be ideal roles and functions of irrigation organizations?
- What should be their goals, structures, levels (national, regional, project, farmer) and their relationship to other agriculture and water resources organizations?

The group's vision is that there should be a national water resources body, whose role is to plan, allocate, regulate, monitor and evaluate the utilization of available water resources. The group's view of the appropriate organizational structure for this body is shown in Figure 8. It would be organized along hydrological boundaries, with regional and river-basin offices. Its Managing Board would include representative of all major water-user agencies.

**Figure 8. Recommended national-level organizational structure.**

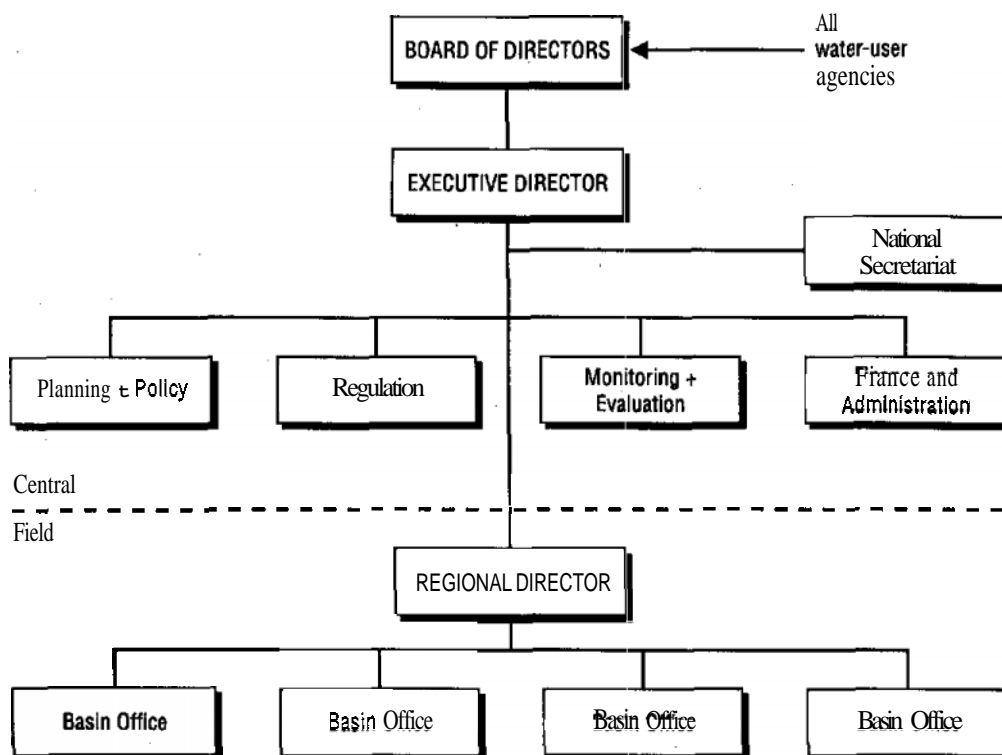

Within this general water-management framework, there should be a national irrigation organization, under the supervision of the Ministry of Agriculture.

The goal of the irrigation organization is to develop those water resources that are allocated for irrigation, and to use them in support of agricultural production.

The objectives of the national irrigation organization will be:

- i. To plan, develop, and construct irrigation systems, and to provide overall supervision of their operation and maintenance
- ii. To delegate and/or to transfer responsibilities for performing operation and maintenance, to organized local associations of water users

The national irrigation organization should be semiautonomous. It should be financially independent of the government in respect of its operational activities, and it should have government financial support for its capital investment programs. It should represent the water users associations in the national water-resources policymaking body.

## **Working Group II: Governance**

The specific question addressed by this group was: what would be the ideal situation, with regard to autonomy, privatization, devolution of power and authority to local levels and/or farmers' level?

The group developed the following rationale concerning these issues :

- i. Centralized control and management are not efficient
- ii. Participation by users is important for ensuring sustainability
- iii. Local authorities and local farmers are familiar with local needs and opportunities
- iv. Budget constraints have been reducing the scope of central government actions
- v. Privatization or devolution will increase the efficiency of resource use

In regard to *autonomy* of irrigation organizations, the group's consensus was:

- i. Water supply is a subsector of natural resources management. Natural resources are public property in which governments must have a regulatory function.
- ii. **Full** autonomy is not feasible. It can be approached by a gradual and dynamic evolutionary process, which must be appropriately managed in relation to traditions and to the political and economic environment.
- iii. Donor agencies should not force their own conditionalities upon this evolutionary process.

Concerning *privatization* the group concluded :

- i. Privatization of existing government irrigation schemes is generally not economically feasible, because they are not profitable.
- ii. Privatization in the sense of transfer to farmers' organizations should be encouraged, within certain limits.

The consensus of the group regarding these limits or framework for *devolution* to farmers' organizations or local government authorities, was as follows:

- i. Devolution should be supported by incentives, and by
  - Involvement of water users in project identification, planning and construction
  - Development of necessary technical skills
  - Follow-up measures by the government agency

- ii. Devolution must also be supported by a good management system which requires the following:
  - accountability and responsibility
  - good leadership

The working group also drew attention to specific aspects of country experiences in relation to governance.

In *Lao PDR*, privatization was made national policy five years ago, and there is a high degree of autonomy in local government because of the country's communication problems. There is now a need for coordination of local government actions, by the national government.

If privatization aims to cover the costs of constructing irrigation systems by requiring farmers to borrow from banks, this can lead to the problem of the banks being unable to produce the required funds.

In *the Philippines* the local government code has devolved construction, operation and maintenance of command irrigation systems to local governments. Farmers participate in maintenance, through user fees. The private sector has invested in profitable development of irrigated agriculture for certain specific crops, such as bananas and sugarcane.

In *Thailand* operation and maintenance are a tripartite responsibility, shared between the national government, local governments and farmers thus:

- i. Routine maintenance is delegated to the farmers.
- ii. Minor maintenance costs are shared in the proportions of 60 percent national government, 20 percent local government, 20 percent farmers.
- iii. Major maintenance is done by the national government. This formula does not work because:
  - The local government units do not want to share the cost.
  - The farmers do not report small maintenance needs but wait for major ones to occur for the central government to shoulder the responsibilities.

## Working Group 11: Legal Framework

This group addressed the following questions:

- How far can we go with the principles of clarity, security and transferability of water rights?
- What should be the limits to these principles ?
- Should rights to water be held by groups or by individuals?

What issues are to be included in laws about water users' associations, and how is the implementation of these laws to be enforced ?

The group's view was that water rights should be derived from a general planning and monitoring framework. This should begin with an inventory and database of available water resources and existing usage. An organization must be established to plan, coordinate and control water abstraction at several levels: national, province/state or basin, project, and users' association. This central agency should develop and continuously update a master plan for water resources, and should administer a system of water licenses.

Water for domestic needs should be regarded as a basic right

Concerning the issues of clarity, security and transferability of water rights, the group took the view that clarity should be inherent in the water license document itself, which should set an upper limit on the amount which the user may abstract. The license should also confer security in the medium-term; but the group felt that water licenses should not be issued in perpetuity since there would be certain circumstances in which it would be in the public interest to withdraw it. (The group gave the example of urbanization, which may create a need to convert agricultural water rights to other 'types of users.) The group considered that water licenses should be transferable, but under some constraints, for which there should be a system of approval of transfers at various levels.

Regarding water users' associations, the group recommended that there should be a law defining how such associations acquire legal identity. Such a law should also define the scope of rights and duties of such associations, including rights to representation in higher levels of water resources management. The law should also specify the scope of the association's authority to enforce its own decisions.

On the general question of enforcement of acceptable communal behavior among water users, the group said that laws should set measurable standards and penalties, while the level of enforcement should be brought closer to the user, and should involve community processes and sanctions. The group drew attention to the need for political will to bring about such systems effectively and to prevent malpractices.

## Working Group IV: Finance

The questions put to this group were:

- To what extent should irrigation water users (in the Southeast Asia region) participate financially ?
- What financing is most appropriate for this ?

The group strongly expressed the opinion that users should contribute towards the costs of irrigation service. The group stressed that irrigation requires elaborate physical facilities and trained management staff; also, that it nurtures general economic development. It cannot be done free of costs; somebody must pay, and the group thought it right that the users or beneficiaries should contribute.

The group identified two sorts of **users**, in the current stage of regional development: farmers, and non-farmers. The latter would include business investors, owners of estates, aquaculturists and any others who may abstract water out of canals but are not traditional farming households; but the group also considered that irrigation underpins national food production **so** that the whole population is in that sense a water user.

The group considered that the farmers have less capacity to pay, **so** they should pay towards operation and maintenance costs a fair amount that is related to their economic statuses, while non-farmers should pay some higher rate.

Capital investment costs should be shared among the government, the farmers, and the non-farmers.



The following chart expressed the group's ideas about appropriate financing contributions and mechanisms:

Investment Source	Capital Contribution	Operation and Maintenance Contribution
Farmers	Labor	Irrigation fee
Non-farmers	Taxes	Irrigation fee
Government	Subsidy	.

### Working Group V: Farmers' Role and Status and Agency/Farmer Relationships

This group was invited to consider :

- What kind of institutional setup is most favorable to achieving farmers' objectives
- To what extent should farmers' exercise control over the institutions
- Whether there are ways in which the institutional setup can protect the interests of small farmers

The group identified four major features which the ideal institutional system would possess, from the farmers' point of view :

- i. It should be responsive to the present and future needs of the farmers. Therefore it should have the flexibility necessary to address change.
- ii. It should have a clear and transparent objective.
- iii. It should not be a controlling organizational structure: rather it should provide avenues for the farmers to participate and to solve problems.
- iv. It should be physically close to the users; therefore, there is a need for decentralization.

The group distinguished two organizational levels, macro and micro (broadly conforming to governmental organizations and farmers' organizations).

At the macro level the group recommended

- i. Use or adapt the existing setup where possible.
- ii. Establish a specialized agency or ministry responsible for all water resources management.
- iii. Rationalize the number of government agencies dealing with water
- iv. Define these agencies' different functions clearly so as to avoid overlapping, and confusion in the minds of the users.

The group emphasized that they did not favor any more organizations, because of the confusing and delaying effects of having too many; therefore when new needs or functions are identified they should be addressed by adapting the existing institutional system rather than creating new bodies.

At the micro level the group recommended:

- i. Official recognition and legal status for users' organizations. to enable them to negotiate their water rights and other rights

- ii. Use of the existing systems wherever possible, without imposing new organizations unnecessarily

Regarding the extent to which farmers should exercise control over the institutions, the group thought they should find a course between the extremes of too much dependence on government handouts, and too little help from the government.

In small irrigation systems, or in remote areas, **the** control exercised by farmers should be great; in large systems the group expects it to be **less**. The amount of control by farmers should also evolve over time, especially in new systems where control by farmers should be taken up in stages, accompanied by external support and training.

The group presented the following guidelines for farmers' involvement at different phases of development:

*Planning.* There should be as much consultation and dialogue **as** possible. Official attitudes should change and social considerations should be incorporated. Consultation should include not only beneficiaries of proposed projects, but also negatively affected groups such **as** small farmers who would be displaced by (for example) dam projects.

*Design.* Farmers should comment on layout plans for canals and drains and location of structures. Traditional types of structures should be used as much **as** possible.

*Consultation.* Farmers should be involved **wherever** possible. This creates a sense of ownership and belonging. It also ensures that various benefits are passed on to the farmers.

*Operation and Maintenance.* Tertiary level maintenance, and operation of small structures, should be handed over to farmers' organizations. For this to work successfully, those organizations need legal status, and a share of the irrigation fees.

Secondary level maintenance and clearing should be the responsibility of farmers' associations, but the operation of secondary irrigation structures should remain in the hands of the irrigation agency.

Farmers should be involved in **all** decisions concerning water distribution, scheduling and delivery.

Regarding the specific question of the rights and interests of small farmers, the group thought that:

- i. A system of water rights should guarantee their security.
- ii. Dominance of large farmers (within the farmers' organizations) should be avoided by rules and regulations and bylaws of the organization. If necessary, the system which confers legal recognition or registration of the farmers' organization's may be used to ensure appropriateness of each organization's rules in this respect.
- iii. Farmers should be assisted to form effective pressure groups or negotiating groups so **as** to resist any encroachments on their rights.

## **EFFECTS OF INSTITUTIONS**

# Impacts of the Institutional System on the Participants and on Irrigation Performance

## A Note for Discussion

*C. M. Wijayaratna*<sup>9</sup>

### INTRODUCTION

THIS PRESENTATION IS largely based on the discussions over the past three days and is intended to deal with some major impact areas of different institutional arrangements on participants and on irrigation performance. This is not a concluding remark. Instead, by comparing and contrasting the possible impacts of various institutional alternatives, this presentation will "open the doors" further for discussion and debate. Following this introductory section the note will be divided on the basis of the major institutional subject areas identified at the workshop:

- Organizations
- Governance
- Legal framework
- Financial framework
- Farmers' role and status

Based on the country reports to the plenary session, the status of respective countries will be summarized first. This **will** be followed by a brief discussion on possible impacts of different institutional forms. Such a discussion should help the country groups in defining objectives of necessary institutional "reforms" or "change" in the next session.

Institutional systems have been clearly defined at the outset by Dr. Douglas J. Merrey. For the sustainable development of irrigated agricultural production systems, it is necessary to optimize the use of appropriate *technologies* and the available (limited) *resources*. Institutions and organizations will have to act as a tool for combining resources and technologies.

About a decade back Prof. Ian Carruthers said: "In Africa irrigation **is** either largely unimportant or unsuccessful ...." However new institutions in certain African countries have already begun to combine the limited water resources and appropriate technologies for more productive and profitable agriculture. For improved performance and sustainability, the institutions should also consider such aspects as environmental concerns, distribution and other social values.

---

9 Head Sri Lanka Country Program. International Irrigation Management Institute. Colombo, Sri Lanka

With regard to the impact of institutions on the individual participant it should be noted that, whatever the nature of the institution, its activities may not be effective unless it involves the participation of the people directly concerned. Economic strength or socio-political power of the individual may not be adequate to reach desired economies of scale or to deal with undesirable socio-political powers. Hence, the organization will have positive impacts on its participants. On the other hand, the productivity and sustainability of institutions or organizations would depend on the creativity, resourcefulness, honesty and hard work of its participants. Such organizations will help augment resources and will improve coordination and cooperation.

An individual autonomous farm system such as a farm irrigated by a shallow well located in an easily renewable aquifer (e.g., flood plains in Bangladesh) may need little or no cooperation from outside." On the other extreme, one finds large canal systems where cooperation and coordination between various actors (farmer-farmer, farmer-agency, agency-agency, etc., and with the organized private sector) play a critical role. Moreover, the impact of institutions on individuals as well as on performance will depend, among other things, on the supply characteristics and scale of irrigation systems, nonirrigation factors related to irrigated agriculture, nonagricultural factors including global trade, political considerations, etc.

At this stage, I like to draw your attention to a diagram on "global economic disparities" shown by Mr. Tissa Bandaragoda:

- If the Philippines is classified with the rich countries and if they are free of erratic water supply characteristics, typhoons, etc., may one argue that this country will show the highest irrigation performance ?
- Similarly, if the market is completely liberalized across the world what would happen to the agricultural product prices in the equilibrium ? Would irrigation be profitable at that point ?

A real analysis of performance may have to consider **all** such externalities

## ORGANIZATION

It was clear from the country presentations that in **all** the countries there exists *at least one* central (or national) organization to deal with water resources development and/or irrigation. In some countries the situation is complicated and "confused" by having a large number of organizations at the national level (e.g., eight ministries in Thailand have something to do with water resources). Similarly, the policy functions are vested with a ministry (such as the Ministry of Agriculture in Malaysia) or with an interministerial/departmental authority (such as the National Water Resources Board in the Philippines).

If we assume that agricultural diversification is essential for economic development of the countries in the region then it is only logical to expect proliferation of organizations for natural resources management because diversification is associated with complexity of functions. However, in order to reduce conflicts or duplication of functions and to improve performance, it is crucial to improve coordination and cooperation between organizations. In order to clarify functions of organizations at different levels, to regulate functions as and when necessary, to relate to other non-water organizations in the agriculture sector, etc., it may be necessary to have a coordinating body with a sufficient degree of authority vested in it. (e.g., National Water

---

10 Even in such cases it may be profitable for the farmers to organize into groups for service functions.

Resources Board [NWRB] of the Philippines). By no means should this imply "centralization of power." This aspect will be discussed further under the topic, "Governance."

At times, large irrigation projects (such as river diversions) are constructed by incorporating community-managed smaller systems. At the completion of the construction phase, the community-based institutions/management organization may be replaced by a large bureaucratic institution. Such an organizational structure may be expensive in its operation, may not be acceptable by the people and the performance will be affected. Similarly, due to the "project-driven" nature of development, "artificial" organizations may be introduced to achieve projects objectives in time. Financial and other support to such organizations may disappear at the end of the project period. Consequently, the organizations may become defunct. It should be noted, however, that there are exceptions: consecutive efforts through a series of projects may help to institutionalize a process or an organization.

## GOVERNANCE

Dr. Douglas J. Merrey has identified three form of governance:

- centralized
- decentralized
- devolved to local authorities

In most of the countries in the region, water resources are owned by the state. In almost all the countries, allocation of authority and power is centralized. However, a trend of devolution of such powers can be observed. For example, Indonesia is trying to decentralize powers to regional levels (funding authority however, may be retained at the center). In the Philippines, the power of Local Government Units is being enhanced. In Lao PDR, due largely to communication and problems associated with accessibility, provinces (especially the Governors) had been enjoying a great deal of autonomy. However, with improved communication and other technologies, the government is now thinking of improving vertical integration.

In order to examine the impact of these institutions (related to governance) on participant3 and on performance, the latter two may need to be redefined. As we are dealing with a limited natural resource, our "participants" should include the members of future generations as well. This is relevant to the sustainability issue. Similarly, as we are dealing with a common good, we may have to consider the distribution or the equity aspect, too.

On the other hand, organized groups of small farmers may also be classified under the private sector. Then the small farmers (or organized landless groups, etc.) may also benefit from privatization and consequently the overall performance may be enhanced.

Similarly, devolution of power to lower levels of government may also be considered as an option under autonomy. Moreover, the causal factors for inefficiencies in the Government sectors may be analyzed and, based on the experiences of private-sector management, reorganization or restructuring of government bureaucracies may be attempted. Further, the involvement of beneficiaries in management may reduce government expenditure on operation and maintenance.

At the irrigation system level, the principal determinant is not the size of the system but to examine "who is responsible for management?" In certain large systems, due to the complexity of hardware and technology, or due to the fact that such systems cover huge watersheds, agency involvement in management may be necessary. The situation may be aggravated if the system is meant for multiple purposes. The performance of such an integrated system may be enhanced **and**

the multiple uses may be optimized (and therefore conflicts may be reduced), and multiple users may be benefited if the state or an autonomous corporation takes the major responsibility for the management of main system and headworks. Even in such cases, federated farmer/user organizations may share the responsibility with the agency. It may be argued that in such systems what is more important is to *institutionalize* a process to ensure productive *interactions* between the agency and the organized user groups.

## LEGAL FRAMEWORK

Laws and regulations should provide an enabling environment for institutional development. Legal framework itself may be considered as a facilitating institution. Dr. Merrey has rightly pointed out that, instead of a limiting and control function, the legislation should play a facilitating role. He expects three major characteristics in water rights: clarity, security and transferability.

In regard to country positions, Lao PDR does not seem to be having a clear legal framework as yet. Administrative procedures play a dominant role in public systems. The country might establish legislation to safeguard community participation. Thailand, too, lacks a general framework and laws are "fragmented" and inadequate. In public systems, allocative rights are vested with the government. In Indonesia, individuals cannot claim legal rights to water resources. The rights are vested with the government. The traditional systems, where customary rights prevail, may be an exception. In Malaysia, depending on the situation, the federal and state governments as well as the individuals possess water rights. Even though the individuals are not allowed to sell their rights, the state rights are transferable.

The evolutionary process of the Philippines legislation is noteworthy. New legislation had been introduced from time to time, depending on the **need** and on the experience gathered, to ensure the rights of the Irrigators' Associations (IAs), the obligations of IAs and NIA, and more importantly the NIA-IA interactions and the collection of Irrigation Service Fees. More recently, laws have been imposed so that authority will devolve to Local Government Units to implement locally funded Communal Irrigation Systems.

In all these countries ownership of water resources **is** vested with the government.

With regard to the impacts **of** these legal institutions, as Prof. Constable pointed out, an appropriate legal framework may establish water and land rights and hence reduce disputes and enhance orderly functioning of irrigation systems. **Also**, legislation may provide for delegation of functions and authorities regarding management control of water, which in turn may lead to a higher degree **of** local management responsibility and, hence, improved performance.

One may argue that, if the responsibility (to manage) and the ownership (of resource) are divorced then the performance may not be optimized. In such circumstances, maintenance may be deferred and gains in the short run may be preferred by the operators. This will not improve viability of systems in the long run. **It is true** that the "ownership" will help reduce the temptation for exploitative use of water and would provide an incentive to maximize profits. However, security of tenure may be provided through alternative mechanisms. Ownership title **is** just one of the many alternatives available for this purpose.

Moreover, the state may act **as** the "savior" of public goods such **as** water resources and provide regulatory mechanisms to ensure their sustainable utilization. Similarly, legislation may provide protective mechanisms to regulate the distribution effects without having adverse effects on productivity.

Last but not least, it should be noted that the adequacy of implementing mechanisms **is** as important **as** legislation.

## FINANCIAL FRAMEWORK

As for Country situations, it was reported that in Thailand, Indonesia and in Lao PDR irrigation water is a free commodity to the farmer. Part of the cost of irrigation, however, is being recovered by electricity charges, etc. It was reported that the Government of Indonesia, is seriously considering the introduction of an "irrigation fee." It should also be noted that farmers, in general, are providing labor and other inputs to operation and maintenance (O&M) at community levels. In certain cases, the entire costs of O&M in community-based small systems, as well as at lower levels of larger systems, are borne by the farmers. In the Philippines, farmers are sharing the cost of construction of Communal Irrigation Systems. In this country, irrigation fees are being collected at the rates of US\$21.00 (wet season) and US\$32.00 (dry) per ha per season. The collection efficiency over the past few years has been reported to be over 50 percent. In Malaysia, the water rates are comparatively low and are about 5–10 percent of the actual cost of water.

Generally, it is expected that local costs of construction of irrigation systems—as in the case of communal systems in the Philippines—and the O&M costs of all systems, should be borne by the users. Also, the efficiency of O&M (and, therefore, the overall performance) will be more if the amounts recovered are kept transparent and closer to the users. At the moment the users are not fully aware where the recovered money is kept or what happens to it. Water charges may also help reduce wastage. On this basis, one may argue that wastage could be minimized if water charges reflect actual costs. In many instances, however, it may not be practical to collect the actual cost of irrigation. Reasons are many. Only a few reasons are quoted below:

- i. Usually agricultural (raw) products are low-valued. Considering the escalating costs of production (and apparent stagnation of grain yields) the *capacity* of the small farmer to pay the full costs of irrigation is questionable.
- ii. The official figures of capital costs may be much higher than the actual costs.
- iii. The fee collected may not be used in an efficient manner so that there is no incentive to pay.
- iv. In large gravity systems, it may not be economical for the tail enders to pay the actual cost of water delivery.
- v. In farmers' view governments are subsidizing the non-farm sectors.

However, for reasons discussed earlier, it is advisable to recover at least part of the actual costs of irrigation. To begin with, the policymakers may design and implement mechanisms (such as farmer involvement in O&M) to reduce the cost of irrigation. Organized groups may be prepared to pay for water if it is delivered in adequate quantities and in time. In large systems, the agency may only be involved in the wholesale distribution of water—say at the distributary/secondary canal levels.

As the government agencies have increasingly found it difficult (or are reluctant) to allocate adequate funds for maintenance, the latter may conveniently be "differed." (This is also motivated by the fact that more often than not foreign donor funds are available for rehabilitation at a later stage.) Moreover, the donors are increasingly becoming reluctant to finance O&M. Hence, it is prudent that users bear the cost of O&M, for better performance.



## FARMERS' ROLE

Individual use of a common good, or individual benefits derived from its existence, provide the motivation for the individual, to engage in group action (Olson 1971). Moreover, in most irrigation systems, group actions can be formulated in such a manner that no one will lose in the group transactions. Hence, the aggregate gain to the system, more often than not, may be regarded as a windfall gain. For example, dissatisfaction with commercial contractors may motivate farmers' organizations to bid for such work: this would result in a net gain to the system. At times, farmers' organizations are "established" by government officials at the field level, not necessarily to fulfill farmers' needs, but merely to follow the orders of higher officials. A federation of organizations based on hydrological boundaries may be useful in avoiding such situations. Federations or councils of user groups can help improve coordination and cooperation, not only among users themselves, but also between the State and farmers' organizations and between the private agencies and farmers' organizations.

If we accept that the ultimate actors who could determine the success or failure of the effort of agricultural production are the farmers, then there is little need to look for a sophisticated and ideological rationale for justifying farmers' participation in decision making related to the production process. Farmers' participation is important, not only to optimize resource use, and to increase productivity and profitability, but also to conserve the natural resources available to irrigated production systems. If we accept this position, then it is only prudent to consider the factors which would influence the sustainability of organized group action. Favorable adjustments in such factors would help evolve appropriate institutions for effective group action and lead to the sustainability of farmer participation. This in turn will help improve performance.

Institutionalization of participatory management in irrigation systems (where a large number of beneficiaries are involved) is as complicated as it is important. One major concern is the form of participation; another is the machinery of participation. We believe that farmer participation in management is a *dynamic and evolutionary learning process*. Hence, one should not aim at a unique form or machinery of participation.

Farmers' participation may not be confined to their representation in management bodies of a particular irrigated agricultural production system. Instead, various forms of participation have been introduced in widely differing political, economic and social systems; and it has been proved that there are many other ways of providing for the participation of farmers in the management of production systems than through membership in decision-making bodies.

Farmer participation in management is not something that can be set once and for all in a particular pattern; it is rather an evolutionary process which is dynamic in nature. It is dynamic in the sense that both the form and the machinery of participation should be adjusted to meet the changing needs. With regard to the form, a large number of patterns may exist between two extremes: from an authoritarian situation where farmers' activities in the production system are governed (or extensively controlled) by the management authority, to a situation where the management decisions of the irrigated agricultural production system are taken exclusively by farmers or farmer groups. The productivity and sustainability of participation will be enhanced through progressive expansion of the farmer's role in management. In a small farm environment where the small farmers perform crucial management functions, a rational institutional framework is necessary to involve these mini-decision-making units through organizational activity and to sustain such involvements. The major characteristics of such an institutional arrangement are given below. The role of farmers' organizations can be institutionalized if the following conditions are internalized:

- a. Institutionalization of the learning process of institution building
- b. Increasing profit to individual participants
- c. Adjustments in the organization to cope with new demands
- d. Bureaucratic reorientation and structural changes in the bureaucracy
- e. Legal support and protection
- f. Information systems and training
- g. Self-correcting mechanisms (monitoring and evaluation)
- h. Financial policy
- i. Political will to accept participatory management

## **Reference**

Olson, Mancur. 1965. *The logic of collective action*. Cambridge, M A Harvard University Press.  
(Reprinted in 1971)

## **COUNTRY VISIONS OF FUTURE INSTITUTIONAL DEVELOPMENT**

*In the final sessions of the workshop (5 November 1993) participants were divided into five country working groups to consider these two questions:*

- *What new objectives and changes (in organizations, governance, legal framework, finance, and farmers' roles) are needed in the irrigation institutions in your country?*
- *What should be the processes for changing the present situation?*

*The reports presented by these working groups are given in this section*

## INDONESIA

The group considered that a new objective of water resources management should be: "To make water more available to each sector."

The new circumstances, which the group perceived as requiring changed official attitudes, included:

- i. Population change
- ii. New economic structure
- iii. Changing patterns of consumption
- iv. Development of industry
- v. Degradation of water resources
- vi. Need to improve efficiency of water utilization
- vii. Long and tedious processes of bureaucracy

The organizational characteristics and functions which the group would like to *see* were:

- i. Flexibility
- ii. Clear and transparent objectives
- iii. Capacity to anticipate changing needs
- iv. Willingness of water users to participate in solving problems
- v. Autonomy

The group recommended that the role of the central government be decentralized to the province and district levels.

The objectives of this would be:

- i. To improve efficiency
- ii. To facilitate local water users, local government and local organizations to deal with the immediate and future needs for water

The group envisaged that the role of the central government would **be** to set guidelines, and to monitor and evaluate processes and performance. Coordination of activities would be the task of Provincial or District Economic Planning Agencies.

Concerning the legal framework, the group said that **all** national laws related to water management and development, and environmental protection for water resources, should be clear and transparent and should provide security for water users. Security for farmers should be provided without sacrificing the interests of non-farming users of water.

The long-term aim should be to give water rights to organized water users' associations.

In future, the role of the legal framework should be a facilitating one, and should adapt to the changing demands and needs of water users.

Regarding the financial structure, the group foresaw farmers would make a substantial contribution to operation and maintenance costs, but it did not foresee that the farmers would pay for capital investments. In the case of farmer-managed irrigation systems, they would continue to contribute all costs.

**Part** of the irrigation fees collected by the government should be returned to the water users' association.

The group recommended that farmers should be involved in all phases of irrigation development: planning, design, construction, operation and maintenance. The farmers' water users' associations should be established formally as legal entities. The right of small farmers should be protected from domination by large farmers in the water users' associations.

The group considered that no single process mode could be recommended for introducing these changes. They should be achieved through a combination of top-down and bottom-up processes.

## LAO PDR

The Lao PDR group recommended a devolved pattern of irrigation governance with these objectives: (i) To improve services and support to water users; and (ii) to regulate activities in the field.

The national government should retain responsibility for:

### Planning

- Budgets
- Monitoring and evaluation
- Human resources development
- Coordination

The provinces should be responsible for:

- Budget requests
- Surveys and designs
- Implementation and operation
- Quality control

The system should be installed initially for a trial period in pilot provinces.

The group recommended that, for coordination, planning and allocation purposes, there should be a National Water Resources Committee, and Basin Representative Committees.

At the implementation level, linkages between the various organizational levels (national, provincial, sub-provincial) needed to be improved, and become more oriented toward promotion and support.

Water rights and land titles needed to be improved. Changes in laws should pursue these objectives:

- i. To give security of water for users
- ii. To protect the total environment
- iii. To create circumstances which will allow collection of irrigation fees

The group recommended, with regard to irrigation finance, that all irrigation systems be owned and managed by farmers, with technical assistance from the Department of Irrigation. Another objective would be to improve markets, by seeking foreign investment in growing and processing.

The processes needed to achieve these aims would vary and would include:

- i. On-the-job training of farmers on model systems
- ii. Setting up scheme-level managing organizations to perform operation and maintenance, then transferring the organization to farmer groups

iii. Active encouragement of foreign investment

Existing policies to make credit available to farmers should be extended. The purpose would be to make farmers self-reliant. This would also reduce government subsidies, and improve irrigation efficiency and sustainability.

Steps required would include:

- i. Pilot self-management projects
- ii. Recommendations based on the pilot experiences
- iii. Assistance from NGO projects
- iv. Credit provision by banks
- v. Political support

## MALAYSIA

The Malaysian group stated that long-term policies for irrigated agriculture were already in existence:

- National Development Policy
- National Agriculture Policy
- Second Outline Perspective Plan

*So all* further changes should be in conformity with this established framework. Features of these policies were:

- Commercialization of agriculture
- Maximum utilization of resources, within environmental considerations
- Mechanization to address labor **shortage** and to improve the farmers' working environment
- Sixty five percent self-sufficiency in rice, the major irrigated crop.

The group proposed that a national organization be established to coordinate all different uses of water.

The group also proposed to strengthen the operation and maintenance capabilities of regional Integrated Agriculture Development bodies.

In regard to system governance, the group recommended that the government should be responsible for policy and infrastructure development, and for allocation and supply of water. Existing farmers' **groups** should be used to undertake operation and maintenance of on-farm irrigation facilities.

Necessary steps would include:

- i. Training and developing awareness of both government officials and **farmers**
- ii. Allocation of funds to facilitate operation and maintenance by farmers
- iii. Official recognition of farmers' organizations

The present system of indirect financing through collection of land-area-based water rates in rice cultivation should be continued. In **all** other crops, except rice, commercialization is encouraged and the irrigation costs should be borne by the farmers. For operation and maintenance in rice areas, government financial support should continue.

## PHILIPPINES

The group from the Philippines stated that irrigation development was a sector of water resources management, so the overall institutions of water resources **must** be addressed first.

The group proposed to strengthen the National Water Resources Board **by** establishing field offices for basin-oriented monitoring, evaluation, and continuing inventory of water resources. The Water Code would need amendment to support this.

In the longer term the group proposed that there should be a Constitutional Amendment which would make the National Water Resources Board a constitutional body, thus ensuring performance of technical staff and Board membership despite political changes.

For the irrigation sector, the group recommended that the role of Irrigators' Associations be strengthened further. Representatives of Irrigators' Associations should be on the Board of Directors of the National Irrigation Administration. To achieve this, the Irrigators' Associations must be federated and a national congress should be assembled at which their representatives would be chosen.

## THAILAND

The group from Thailand specified the following objectives for institutional changes:

- To cope with the rapid changes in the national socio-economy, in order to compete in the world markets
- To achieve sustainability in resources management
- To alleviate the standard of living of the rural population
- To improve the efficiency of management through devolution of authority

Regarding the five subject areas of the meeting, the group proposed these changes for their country:

### Organizations

- a. Establish a Ministry of Water Resources.
- b. Establish national, basin and subbasin Water Boards or Committees

### Governance

- a. Centralize the allocation of resources and budget.

- b. Gradually devolve power in operations, maintenance and management to users' groups.
- c. Encourage privatization.

## **Laws**

Develop a comprehensive Water Law, on these lines:

- a. Review and revise existing laws.
- b. Define water resources as belonging to the state.
- c. Evolve a water rights permit system.
- d. Conserve and protect water resources.

## **Finance**

- a. Apply the concept that "Users Pay."
- b. Adopt a differential water-pricing system, reflecting the different return-values of different activities.
- c. Encourage water saving, through application of progressive rates and incentives.

## **Government-Farmer Relationships**

- a. Legalize water users' groups and associations, with the aim of entitlement (but not compulsion) to receive government assistance.
- b. Provide opportunities to irrigators to participate in decision making.
- c. Adopt the self-help concept in government-assisted program.
- d. Strengthen managerial and marketing capabilities.

## **The Group's Additional Comments**

- National agricultural policy should be reviewed.
- Existing priorities in water allocation also needed review.
- Planning should be oriented to basins rather than to projects.
- Demand management should be emphasized.

## **Change Process**

The **group** thought that change should be brought about by:

- Building consensus



- Education of the public and politicians
- Joint, coordinated efforts by all concerned agencies
- Exploiting crisis situations to promote changes

The group stressed the urgency of change, and **said** that the time frame should be the 7th National Economic and Social Development Plan, beginning in 1996.

## **SYNTHESIS**

# Regional Features of Institutional Evolution in Southeast Asia

*Charles L Abernethy*<sup>11</sup>

IN THIS CLOSING summary of the Workshop on the Institutional Framework for Irrigation, I will attempt to identify some principal areas where consensus, or at least convergence of thinking, seems to have been demonstrated by the five country statements **as well as** by other things that have transpired during this week. Perhaps, **as well as** indicating areas where certain degrees of agreement are emerging, I should also draw attention to one or two quite important areas where that has not happened.

At the beginning of the workshop, maybe, we doubted that anything like a regional consensus could be found. We noted that it is not practical to prescribe some theoretically ideal arrangement of institutions that countries should adopt. Reasons of history, social structure, economic development and many other factors which might together be called the external context of irrigated agriculture, have exerted various pressures specific to each country, and the combined outcome is that we see today five very different sets of institutional arrangements in these five countries.

In the first day of the workshop we described, according to the scheme of analysis provided by Dr. Merrey's keynote address, these five present situations. Next day we listened to and discussed several other kinds of institutional arrangements that exist in other parts of the world. By the end of that day the diversity of possibilities seemed very great. In these circumstances, how should any country choose a path of institutional reforms; indeed, why undertake reforms at all?

During the third and fourth days we have, essentially, been trying to deal with those two questions. We addressed the institutional scene analytically, asking what improvements we might like to see in specific areas such **as** water laws, farmer/agency relationships and *so* on. We also addressed it functionally: how good is the system at serving its primary clients; what impacts does it have; are these effects verifiable by concerned parties (or, **as** the jargon puts it, do we have accountability?).

It seems to me that in these processes of analysis and synthesis our working groups have been rather successful, and have identified in their final country statements more commonalities than might have been anticipated. Even so, there may be a little difficulty in finding the correct language for expressing the degrees of convergence that we have found. Not many matters are really unanimously agreed among the five country groups. Where I use words like consensus it is meant to convey a strongly perceptible majority trend, but the country reports may sometimes show certain areas of dissent.

---

<sup>11</sup> Senior Technical Advisor, IIMI.

## LAWS

In reviewing the areas of convergence, I prefer to begin with the legal framework. If we do not get that right, there is a strong possibility that actions in other subsectors will not succeed.

In many countries on the road to development—this is not specific to Southeast Asia—governments during the **1960s** and **1970s** had a tendency to undertake executive or administrative actions that did not necessarily conform clearly with law. The development process itself took priority; appropriate legal systems to regulate it evolved more slowly, so certain executive actions are taken in a sort of legal vacuum, or at least in an unsatisfactory legal context. This seems to be the case with water rights in the region. New irrigation systems were created, but often governments did not feel obliged to arrange formal, limited water rights for such new abstraction facilities, nor to define where they ranked in priority compared to other users of water upstream and downstream. Now, **as** we move towards increasing autonomy or devolution in the governance sphere, this lack of clarity in water rights appears dangerous to the interests of irrigators.

In his keynote address, Dr. Merrey spoke in favor of "clear, secure, and transferable" water rights for users or user groups. There seems to be **a** strong consensus in favor of the first two of these features, clarity and security. In general, our country groups do not seem convinced about the merits of transferable or marketable water rights. Some countries, particularly the Philippines and Malaysia, have certain of the legal structures of water rights already in place, but it appears that everywhere there is work to **be** done to create regulatory systems within which irrigators will really know what their rights to water are, whether anybody **else** can claim priority at times of crises, and whether there are any circumstances in which the rights might be taken away from them.

Although the groups apparently do not at this time feel comfortable about the question of transferability of water rights, it will tend to arise inevitably when water rights become formally assigned. Throughout the region, we can find some irrigation systems which are nowadays falling out of **use** or reducing their levels of activity. In a system of formally documented water rights, such situations would automatically provoke the question how such rights are to be transferred, when they are no longer being beneficially exercised by their holders.

Another aspect of the legal framework, about which an adequate consensus appears, is the need for a proper legal identity for water users' organizations. The Thai group differentiated this point slightly by saying that there ought not to be compulsion to conform to an official model. However, **all** agree that laws should provide a framework expressing the freedoms and constraints within which such associations may operate.

## ORGANIZATIONS AND THEIR FUNCTIONS

There is a general consensus in favor of devolution of functions to lower levels where appropriate. The form that this will take varies and is not clear in **all** cases: devolution could be to smaller hydrologic units, or to units that match existing local government areas (**as** in the Philippines), or perhaps on some other basis. The justification for decentralization or devolution is perceived (most frequently) in terms of facilitating an increase in the farmers' role in management. It is also considered **as** a way of developing more efficient operation and maintenance processes, because organizations that are controlled at **a** more local level should be more responsive to their **users**.

There is also a common wish to move towards some stronger organizational structures that can reflect the growing significance of managing water resources at national or hydrological basin

levels. This might take the form of a full Ministry of Water Resources as proposed by the Thai group, or some kind of National Water Resources Board as suggested by most others. The characteristics desired in such organizations are also agreed in most of the country statements: they should coordinate all uses of water, their processes should be transparent, they should be administered with reference to hydrologic basin units, and they should monitor the resources and the consumption of water and plan for future requirements. The question whether these organizations should be politically controlled or "independent" — technocratic commissions were mentioned by some — was not resolved.

The problem of the large number of public organizations which have some functional relationship to irrigated agriculture was mentioned by various speakers. In general, the multiplicity of organizations **is** not, in itself, the problem as it reflects the wide variety of different ways in which the governmental system is involved with aspects of irrigated agriculture. There **is** however a wish for improved clarity in the definition of the goals and the functions of each member of the institutional set, so that sources of inefficiency such as functional overlap, and the frictions these cause, can be reduced.

## GOVERNANCE AND THE ROLE OF FARMERS

It is appropriate to consider together the questions of governance of the system, and the role of farmers, because the discussions have shown that at the present stage of development these areas are closely interconnected.

There **is** consensus about the general principle of expanding the role of farmers in governance at the lower levels of control. The situation is not **so** clear farther up the hierarchy of authority. The Malaysian view **is** that farmers' organizations should confine themselves to organizing operation and maintenance at lower levels; other countries seem to see a larger spreading of participatory processes and, in some cases, privatization.

Perhaps it would be accurate to say that, at this time, it is not possible to predict how far the development of participation will go. Most countries expect it to proceed farther, into new administrative areas, but the possible limits to this process have yet to be explored.

The views expressed in this area are probably quite significantly different from those that predominated ten years ago. Today, there is greater confidence in the capacity of the farming community to undertake management functions. There is also a general doubt that older management structures can deliver what **is** now wanted, in terms of overall system performance, cost control and reduction of water consumption.

Development of water users' associations is therefore a general goal. In the Philippines, the aim is to foster development of multifunctional capabilities, so that the associations can take up the delivery of support services to farmers. The Lao PDR group **aims** to have **all** irrigation systems farmer-owned, with the role of the Department of Irrigation confined to technical assistance. The wish to make such organizations self-reliant, and thus to restrict the governments' need to subsidize the irrigated agriculture sector, is general, although in Malaysia the strength of the overall economy makes these pressures less acute.

## FINANCE

There is general support for the principle that users of services should pay for them rather than expect these costs to be supported by other sections of the community. On the other hand, everyone finds it difficult to see how farmers can meet the true costs of irrigation just now. Total costs are high; agricultural earnings are low. These must converge more, before full cost recovery policies can be expected to succeed.

The attitudes to subsidy, or transfer of costs to other!, naturally vary according to the state of the external economy and tax-base. It is certainly more possible for Malaysia to operate a subsidizing policy than it is for Lao PDR. There is however a common awareness, derived from the experience of more affluent countries such as Japan or France, that ultimately subsidy policies tend to generate socio-political difficulties, and that it may be better to move away from such policies as early as circumstances allow.

Where there is acceptance of the general goal of full cost recovery, there remain a number of serious problem areas which the country groups did not address. Farmers may agree to pay the immediate costs pertaining to actual operations on their systems. Costs which are less direct are likely to be more difficult: these include the costs of sustaining the superstructure of the irrigation agencies (headquarters, provincial offices and so on); historic costs invested in existing facilities; and future investments such as renewals and extensions. If cost recovery is pursued into areas such as these, it is likely to create a demand by the farmers, as payers, to exert more control over these matters.

Cost recovery policies, if they are strengthened, will also sharpen various other questions, about the destination and application of the funds after they have been collected from the users.

Thus financing questions can be expected to influence the other questions we have discussed, such as governance, organizational autonomy, and the appropriate degree of farmers' participation in management decisions.

## CONCLUSION

Although the five countries that participated in this debate possess at present very different institutional arrangements for managing their irrigation, it seems that they share a quite wide range of common views about the kind of institutional framework that they would like to see. All want to see improved and formalized legal rights to water; decentralization of government irrigation organizations; increased roles for the farming community; and more (but probably not total) contribution to management and operational costs from the users of water.

Since the countries *me* moving towards these goals from differing present positions, the paths which they must pursue are not the same. We have used this week to think about the goals; maybe, now that those are somewhat clearer, we could next turn our attention to the management of the process of changes that is necessary in order to attain those **goals**.