



AgEcon SEARCH
RESEARCH IN AGRICULTURAL & APPLIED ECONOMICS

The World's Largest Open Access Agricultural & Applied Economics Digital Library

This document is discoverable and free to researchers across the globe due to the work of AgEcon Search.

Help ensure our sustainability.

Give to AgEcon Search

AgEcon Search
<http://ageconsearch.umn.edu>
aesearch@umn.edu

*Papers downloaded from **AgEcon Search** may be used for non-commercial purposes and personal study only. No other use, including posting to another Internet site, is permitted without permission from the copyright owner (not AgEcon Search), or as allowed under the provisions of Fair Use, U.S. Copyright Act, Title 17 U.S.C.*

The Australian Centre for International Agricultural Research (ACIAR) was established in June, 1982 by an Act of the Australian Parliament. Its mandate is to help identify agricultural problems in developing countries and to commission collaborative research between Australia and developing country researchers in fields where Australia has a special research competence.

Where trade names are used this does not constitute endorsement of nor discrimination against any product by the Centre.

ACIAR PROCEEDINGS

This series of publications includes the full proceedings of research workshops or symposia organised or supported by ACIAR. Numbers in this series are distributed internationally to selected individuals and scientific institutions. Previous numbers in the series are listed on the inside back cover.

© Australian Centre for International Agricultural Research
G.P.O. Box 1571, Canberra, A.C.T. 2601

Ferrar, P. 1988. Transport of fresh fruit and vegetables: proceedings of a workshop held at CSIRO Food Research Laboratory, North Ryde, Sydney, Australia, 5-6 February 1987. ACIAR Proceedings No. 23, 77 p.

ISBN 0 949511 64 1

Typeset and laid out by CPN Publications Pty. Ltd., Canberra 2609.
Printed by Union Offset, Fyshwick.

Transport of Fresh Fruit and Vegetables

**Proceedings of a workshop held at
CSIRO Food Research Laboratory,
North Ryde, Sydney, Australia,
5-6 February 1987**

Editor: P. Ferrar

Contents

Foreword

J.R. McWilliam 5

Workshop Summary 7

Research Papers:

Rail transport of Queensland horticultural produce

R.A. Jordan 10

Shipment of onions under ambient conditions: fantainers

A.R. Irving 15

Shipping cocoa and coffee in naturally ventilated containers:
the CSIRO ventainer

A.K. Sharp 20

Bulk shipment of oranges in refrigerated containers

B.L. Tugwell 26

Use of refrigerated containers to transport fruit and
vegetables in Papua New Guinea

G. Atkinson and K.J. Scott 31

Design of packages for fruit and vegetables for
transport by sea or land

I.D. Peggie 35

Simulated commercial export of mangoes using controlled
atmosphere container technology

B.C. Peacock 40

Disinfestation of durable foodstuffs in ISO containers using carbon dioxide

H.J. Banks 45

In-container cold-disinfestation of fruits and vegetables

A.K. Sharp 55

Summaries of Information and Review Papers:

Constraints on the export of fruit and vegetables from

Australia and market requirements overseas

J.D. Baker 64

An exporter's approach to shipment of fresh produce from Australia

T. Pilavachi 67

Transport of perishables by road

T.O.D. Hughes 69

Shipment of fresh produce by air

Roger Parkes 71

Selection of the right packaging: engineering aspects of package design

L.B. James 72

Transfresh system of atmosphere control

Glen Adams 74

Participants 76

Foreword

ACIAR has in progress a project concerned with the postharvest transport of fresh fruit and vegetables in Papua New Guinea that has demonstrated how fresh produce can be moved from the Highlands to the main markets of Papua New Guinea, and (contrary to previously held local belief) arrive in good condition.

The results are currently being put into practice with the establishment of a regular containerised transport system, and its successful functioning should make a significant difference to the economy of the PNG Highlands, and to the country as a whole. Studies are also under way to extend these principles to the transport of produce within and between other Pacific countries.

The project has involved cooperation between ACIAR, the PNG Department of Agriculture and Livestock, the CSIRO Division of Food Research, the New South Wales Department of Agriculture, the Australian International Development Assistance Bureau and the New Zealand Ministry of Foreign Affairs. We thank all these organisations for their cooperation and assistance during the course of the project.

The subject of postharvest transport concerns all producing nations, however, and Australia still has many problems to solve itself. ACIAR supported the present workshop to enable the topic to be aired and discussed very broadly, and the following papers indicate the successes that have so far been achieved, and the problems that still remain.

We thank Mr Kevin Scott and his colleagues, and the Officer-in-Charge and staff of the CSIRO Food Research Laboratory, North Ryde, for their hospitality and excellent organisation of a lively and very useful meeting.

J.R. McWilliam

Director

Australian Centre for International
Agricultural Research

May 1988

Workshop Summary

The workshop was held under the auspices of ACIAR Project 8354 (Postharvest Transport of Fruit and Vegetables in Papua New Guinea). However, believing that the whole subject of postharvest transport of horticultural produce could benefit from wide discussion, the Australian project leader, Mr Kevin Scott from the New South Wales Department of Agriculture, organised the meeting to include a wide-ranging mixture of growers, agricultural advisers, wholesalers and exporters, quarantine officers, scientists, and experts on transport, packaging and refrigeration systems. The workshop was held at the CSIRO Division of Food Research at North Ryde, where Mr Scott is located. These Proceedings include only the formally presented papers, but other participants assisted by chairing sessions and by contributing to the discussions.

The papers presented at the workshop were as diverse as the range of participants. Some were detailed research reports on trials, such as of a new type of ventilated container, or controlled atmosphere storage of a particular commodity; others were general reviews of requirements and possibilities of a particular mode of transport, or export prospects, or packaging. The styles of the presentations were equally varied, and ACIAR has decided to publish only the research papers in full here. The other papers are included in abridged form, but copies of the full text of individual papers may be obtained on request from ACIAR.

Despite the diversity of presentations, several common themes arose repeatedly. These may be summarised as:

- (1) market requirements;
- (2) product requirements; and
- (3) the need to coordinate all requirements.

Market Requirements

There were considered to be good prospects for Australia to increase its exports of various horticultural products, but only if it supplied what particular markets wanted. This meant not only produce of good quality, but also produce of a particular degree of ripeness or sweetness suited to a certain market, regularity of supply, and often in a package size different from standard Australian packaging. The international market is highly competitive, and many speakers stressed the importance of finding out *exactly* what a market wants before attempting to supply it. Poor performance may jeopardise subsequent Australian prospects. To a degree the same principles also apply to supplies for domestic markets, which are only likely to expand significantly if the product suits the buyers.

Product Requirements

Australia can produce fruits and vegetables of excellent quality, but ensuring that they are still of good quality when they arrive at their final destination is not easy. Given the competitiveness of markets it is essential for produce to arrive in the best possible condition, which requires knowledge of the exact (and differing) requirements for each product. These include the degree of ripeness for harvesting, the individual temperature and humidity requirements during transport, and packaging requirements to permit any necessary ventilation while minimising water loss and mechanical damage.

Each particular field-to-market combination may require a separate assessment, depending on transit time involved and individual market requirements. Many of the treatments required, such as atmospheric control, refrigeration and packaging, may be expensive, and it is also necessary to calculate the best balance between quality at out-turn and the cost of achieving that quality.

Coordination of Requirements

Achievement of export potential requires coordination of many links along the chain of delivery. Growers and wholesalers need to get together over packaging and supply; exporters must arrange with transport operators, whether road, sea or air, as well as with the buyers in the overseas countries; scientists and technologists must ensure that knowledge of product requirements is passed on to those who require to use it. Packaging experts need to determine requirements from all points of view, and then design the cheapest packaging that is able to meet all the specifications.

Participants repeatedly stated that this sort of coordination only rarely occurs, and until it improves greatly there will be relatively little expansion of Australia's horticultural export trade. In some cases the lack of communication is because of primary producer politics; in others it is just because of poor organisation.

It is worth noting that a significant government report that appeared shortly after the Workshop was held also highlighted this same need for the different sections of the industry to come together to improve the efficiency of operations. The report, entitled "After the Harvest: Opportunities and Technologies in Horticulture," was prepared by the Technological Change Committee of the Australian Science and Technology Council (ASTEC), and should be studied by all interested in this field. Copies may be obtained from the Technological Change Committee, PO Box E169, Queen Victoria Terrace, Canberra, ACT 2600.

Research Papers

Rail Transport of Queensland Horticultural Produce

R.A. Jordan *

OVER the past 10 years enormous changes have taken place in the handling and transport of goods within Australia. The concepts of unit load handling, palletising and containerisation are now accepted through most industries. In the horticultural industries those practices, while widely used, are still far from universal. In coping with change the horticultural industries had, and to some extent still have, the additional problem of learning to live with the complexities of temperature management.

For the typical grower today, not only are there the management decisions related to the growing of the crop, but there are now major decisions to be made regarding packaging, type of transport (road or rail) and refrigerated or nonrefrigerated systems. While many would say the choices are obvious, it usually is not quite as simple in practice. The ideal system of unit handling in a temperature-controlled environment is frequently unavailable, inconvenient or uneconomic. Thus decisions need to be made on the use of nonideal systems.

In Queensland there is still widespread use of less than ideal handling and transport systems. This paper summarises much of the current technical knowledge of the rail transport of fruit and vegetables as it relates to transport of Queensland produce both within that state and to interstate destinations. The information summarised here has been gathered by the author and co-workers over a number of years.

Equipment in Use

Approximately 75% of Queensland horticultural produce carried on rail is sold outside the state (COD, private communication). In addition, much of the production occurs in the northern part of the

state from Bowen to the Atherton Tableland. With the quantity of produce consigned to Sydney and Melbourne being as large as it was and with the cost of labour so high, the rail gauge change in Brisbane became a severe restriction to the flow of fruit and vegetables from North Queensland to southern destinations.

The system in use, virtually unchanged for many years, involved manually unloading Queensland louvered wagons and passing the packages across a platform to be loaded into a southern louvered wagon. The availability of containers and increased awareness about the need for sound handling practices hastened the near-abandonment of this highly inefficient, labour-intensive system.

Ambient Temperature Equipment

Louvered wagons are still used to some extent for interstate trade, both within Queensland between growing areas and Brisbane, and between Brisbane and southern centres. There is still significant use of them for intrastate transport particularly for journeys of less than 1 day.

The bulk of produce moved interstate is shipped by container. Two container types are used for this purpose. The VC type is a partially ventilated container of steel construction. It has louvres in the fixed sections of the sides and narrow louvres in the double side doors. There is no ventilation in the ends. The container is unlined except for a ply sheet fixed close to the roof. The ply sheets in some containers have a reflective insulation sheet on the upper surface. There are approximately 400 of these containers in use.

The other major container type widely in use for banana transport is the side-loading type, as represented by the MSL and VSL class. These two containers are very similar in construction differing only in relatively minor mechanical ways. They have a metal floor, ends and roof, and large wire

* Queensland Department of Primary Industries, Sandy Trout Food Preservation Laboratory, Hamilton, Queensland 4007.

mesh gates at the side. These gates can be removed allowing full access from either side for loading. The wire gates are covered by canvas sheeting lashed to the container. Ten standard pallets can be carried.

Refrigerated Equipment

All of the refrigerated equipment now in use for fruit and vegetable transport is in the form of containers. These containers vary somewhat in their construction detail depending on date of manufacture. They are of the thin side wall type common in road trailers. This construction technique allows the use of standard pallets in the container by reduction in wall insulation thickness. Containers typically are fitted with either Thermoking or Carrier transport refrigeration units. This equipment varies to a moderate extent in specifications.

The interior of the container has a flat floor, assuming that pallets will be used to form a return air path, a bulkhead around the evaporator to duct the return air from the floor opening to the unit. Delivery air is discharged directly to the top of the load with no ducting, with a wire grill forming a barrier to overstacking.

This type of container can accommodate 12 pallets. These pallets are normally loaded from the side, and positioned so that the four pallets at either end of the container have their openings forming an air return channel. The four pallets across the middle are loaded with pallet rails perpendicular to the direction of air flow.

In the early days of refrigerated container use, four empty pallets were used on the floor across the middle of the container to provide a clear return air channel. This practice has largely been abandoned, not only because loading in this way is more difficult and time consuming, but also because of the cost of extra pallets and increased risk of losing these empty pallets.

Performance Evaluation

During the 1960s there was a considerable amount of research carried out in Queensland and New South Wales on the rail and sea transport of bananas. This work mainly involved the use of louvered wagons and ice-wagons, and how this equipment and stacking patterns within them affected mixed ripe of bananas.

No further work was done in Queensland until 1977 when the author initiated new transport

research, initially on road transport and fairly soon afterwards on rail transport.

All of the commercial transport equipment currently in use, and some not now in common use, has been subject to experimental investigation of some type, although in most cases the work has been carried out in conjunction with commercial consignments, and detailed basic studies have not been possible.

All measurements and evaluations had to be designed to be compatible with these imposed constraints. Most work has been with bananas from North Queensland, and to a lesser extent tomatoes, mixed vegetables and pineapples.

Ambient Temperature Transport

Bananas Bananas are the major crop now transported at ambient temperature, although large quantities of watermelons, potatoes and pumpkins are also carried. Most of the banana crop in fact is transported at ambient temperature, with rail being a major carrier. When the concept of containerisation caught on with the banana industry it was also becoming popular with other industries to such an extent that in 1984 VC containers frequently were unavailable to the banana industry. The MSL class of container was provided and used reluctantly by some sections of the North Queensland industry. They believed, based on some casual observation at rail sidings, that the fruit would be exposed to substantially higher temperatures and suffer a quality loss as a result.

A series of studies was performed by the Queensland Department of Primary Industries (QDPI) to determine the suitability of the MSL container for banana transport. The first trial (Jordan 1985a), in very warm ambient conditions in late spring, demonstrated that the fruit in the MSL on average was about 1.5C° higher in temperature than the VC, although there was no difference between temperatures on arrival. The mean air temperature in the space above the load was 4C° higher and the maximum temperature was 9C° higher. No differences, however, were detected between fruit from the two containers in eating quality (mean optimum eating quality 6.9 — rating scale: 9 = like extremely, 1 = dislike extremely), colour quality (mean optimum panel score 6.2), shelf life (mean 6.6 days) and green life change ($GL_{20} = 0$).

It was clear from the temperature distribution that the higher overall temperatures of fruit in the MSL were the result of additional heat penetration

through the roof and canvas-sheeted side of the container. Typical temperature plots are shown in Fig. 1.

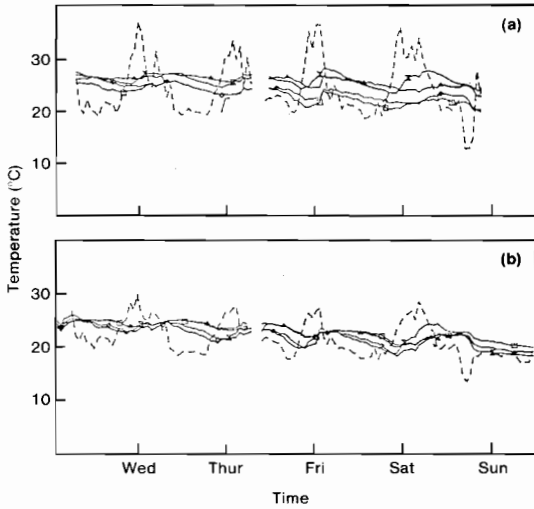

Fig. 1. Typical plots of temperatures measured in an MSL container loaded with bananas travelling between Tully and Melbourne in November. (Air temperature measured between roof and top of load shown dotted.)

A further trial during hot early autumn weather using an MSL container investigated the use of reflective sheeting as an insulator above the load (McLauchlan and Jordan 1985a). On this occasion the insulation was placed too close to the top cartons of the load, and while heat penetration into the load was reduced when the hot air occupied the space above the load, cooling of the load was slowed when cool air occupied this space.

An additional comparison was made in this trial between fruit carried in the MSL and fruit carried simultaneously in a refrigerated container (SRC). Approximately 10% of fruit carried in the MSL commenced ripening in transit. This can be attributed directly to the very short green life exhibited by some of the fruit (5% of fruit with $GL_{20} < 10$ days) at harvest added to the effects of sustained high temperatures in New South Wales and Victoria. The mean temperature of the fruit on arrival in Melbourne (23.6°C) was little different from the mean temperature of the fruit on departure from Tully (23.9°C) 6 days earlier, although the spread of temperature had increased. This contrasts with a fall of 4.7°C between Tully and Melbourne for the previous late spring trial. When prematurely ripened fruit was discarded, no differences in eating

quality were detected between fruit from each container (mean optimum panel score 7.2). The rate of colour development of fruit from the refrigerated container was somewhat less after 4 days gassing (colour score — scale: 1 = green, 5 = yellow — SRC 2.6, colour score MSL 3.4). After four more days at 20°C the difference was reduced (SRC 4.4, MSL 4.7).

A further trial in winter again demonstrated the effects of ambient conditions (Jordan 1985b). Mean fruit temperatures in an MSL container fell 11.9°C between Tully and Melbourne (Fig. 2). However the use of an insulating sheet of corrugated cardboard between the canvas side and the carton walls resulted in a temperature fall of 1.5°C less than when no insulation was used. Calculation of the chilling potential as the total degree hours below 12°C showed a real effect of the insulating layer with outside layer cartons totalling 41.5 degree hours for the noninsulated section and 3.4 degree hours for the insulated section.

No differences in eating quality were detected between fruit from the MSL and fruit from a refrigerated container (QRC) simultaneously held at a steady 16°C . Any differences in chilling symptoms which may have occurred were possibly masked by a uniform low level of chilling symptoms present in all fruit.

Tomatoes One study has been carried out using ambient temperature rail equipment with tomatoes as load.

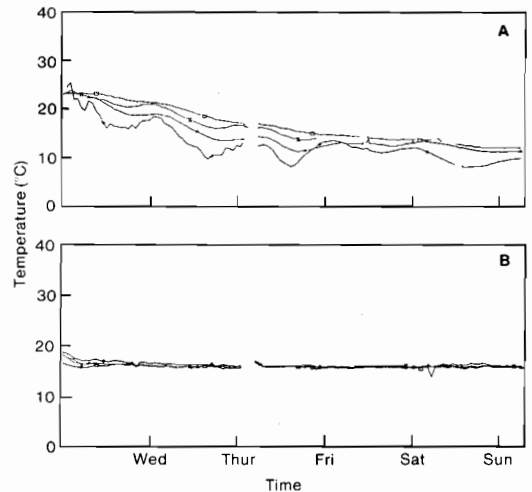

Fig. 2. Typical plots of temperatures measured in an MSL container (A) and a refrigerated container (B) loaded with bananas travelling between Tully and Melbourne in July.

Ripening fruit were transported in a VC container from Bowen to Sydney in early September (McLauchlan and Jordan 1986b). Temperature changes observed were very similar to those for bananas even though it might have been expected that ripening tomatoes would behave rather differently from green bananas. Fruit temperatures, 10–12°C at loading, warmed to 14–17°C and commenced cycling with ambient temperature. There was no indication of significant warming effects from respiratory heat. Mean final temperature was 16°C.

To summarise, all of the data collected for low to moderate respiration rate products confirm that the major factors determining product are the ambient conditions and heat transfer characteristics of the container. Product temperatures tend to follow mean ambient temperature, with temperatures in outer layers of stacks showing largest cyclic variations. Top and bottom layers show the largest temperature variations, particularly in the MSL. Fortunately, at most times of the year Queensland produce is cooled beneficially as it travels south. In midwinter this can be a potential problem with bananas at risk from chilling injury. Steps can be taken to reduce the risk.

Refrigerated Transport

Some general comments are required before considering results of specific experimental studies.

Broadly speaking, both the Thermoking and Carrier refrigeration equipment in use operate in the same way. Both are directly diesel engine-driven, and as a result cannot operate with an on-off cycle as static refrigeration does. Instead they use a cool-head cycle to maintain temperatures. Consequently delivery air temperatures undergo quite large swings. In addition, because of size/weight constraints, evaporator coils are relatively small in relation to capacity, producing delivery-return temperature differences of up to 8°C. These large differences can be reduced near the thermostat set point by a capacity reduction system (compressor unloading) if fitted.

Some early work soon after the introduction of refrigerated containers demonstrated the susceptibility of the system to the 'overshoot effect' found, but to a lesser extent, in older types of shipping containers. It generally occurs in situations where a relatively warm load is stored in a container in such a way that heat exchange is slow. The result is, not uncommonly, excessive cooling of part of the load

before recovering to approach equilibrium at the set point.

Other Recent Studies

In a trial in warm-to-hot weather in early autumn, bananas at 23.9°C were stowed in a refrigerated container and transported to Melbourne (McLauchlan and Jordan 1985a). Mean temperature on arrival was 19.5°C with considerably reduced spread. The thermostat was set at 15°C. Although a number of alternative interpretations are possible the slow cooling of the bottom cartons of the transversely stowed pallets suggest that disruptions of return air flow affected the overall performance of the equipment. Alternatively, a calibration problem could have been the cause but no check of this was possible.

The fruit when ripened were very uniform in colour development but were not detectably superior to those transported without refrigeration.

In a trial in midwinter, fruit stowed into a refrigerated container in Tully at 23°C rapidly cooled to 16°C and remained near this temperature for the duration of the trip to Melbourne (Fig. 2) (Jordan 1985b). Temperature spread was exceptionally low. The range of means was in fact only 15.9–17.2°C, the lowest range ever encountered with this type of equipment. For much of the trip, and particularly at night, ambient temperatures were below thermostat temperature and the refrigeration was running on its heat cycle.

Experimental Equipment In about 1980 the State Rail Authority of New South Wales when considering additions for dry cargo container purchases decided to develop a container which they believed would incorporate features making it more suitable for carrying fruit and vegetables than the VC container. Plans of such a prototype container were completed but this was not built because of a change in priorities. Some years later the State Transport Authority of Victoria, on behalf of Railways of Australia, took on the task of building the prototype for testing. QDPI was requested to carry out performance testing of this container. The testing program was planned to include static heat entry testing and commercial consignment monitoring using bananas and tomatoes (or mixed vegetables) in both summer and winter.

Only one heat entry test was performed (McLauchlan and Jordan 1985b) as well as a winter banana consignment study (McLauchlan and Jordan 1986a) and an early spring tomato consignment

(McLauchlan and Jordan 1986b) study. The concept was ultimately abandoned because of mechanical problems in the design.

The container design was very unconventional, having doors the full length of both sides which were able to be opened to allow access to the full side for loading. There was no side ventilation. Instead the floor was transversely slotted to allow entry of air, and the roof contained rows of holes along either edge. The expectation was that air would flow between floor and roof vents when the container was in motion, providing the necessary ventilation.

The heat transfer characteristics were very much as expected, with the solid walls reducing the rate of heat transfer to or from the outside. Temperatures in top and bottom cartons showed little effect of the entry of air, and temperature fluctuations in the experimental containers were considerably lower than in the VC used for comparison. Typical temperature plots are shown in Fig. 3.

Air flow measurements in transit showed only low velocity movement through the top vents (384 mm/sec mean).

Overall the prototype container performed better than a VC, more as a consequence of its insulation

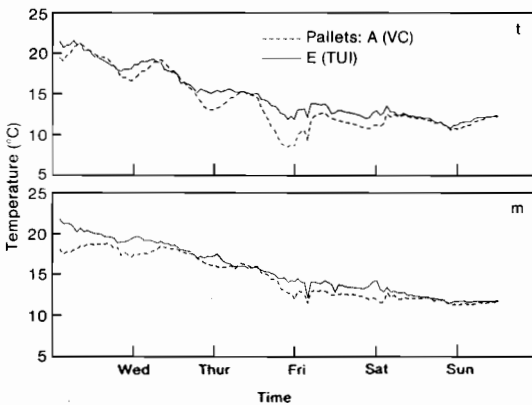

Fig. 3. Typical plots of temperatures measured in the experimental container and a VC container loaded with bananas travelling between Tully and Melbourne in August. (Air temperature measured between roof and top of load shown dotted.)

properties and its white exterior than for any other reason.

Future Developments

It is difficult to see major changes occurring in rail

transport procedures or equipment in the near future. While the demand for rail capacity for fruit and vegetables continues to increase, no plans currently exist in Queensland to satisfy it, as other priorities are presently being given precedence. The large difference in capital cost of refrigerated containers compared to dry cargo containers and the shortage of back-loading from southern states also make the purchase of such equipment unattractive to railway departments with many demands on their capital.

Following the abandonment of the experimental container it was reported that some state railways were looking seriously at the 'tautliner' concept as the new generation of dry cargo containers.

Technically, it seems unlikely there will be major changes to the type of equipment in use. Refrigeration equipment is produced overseas and Australia will be tied to progress there. Work is continuing on improving capacity while increasing air flow and reducing evaporator coil temperature drops, and incremental benefits will ultimately flow through.

It is interesting to note that the Queensland Railways and Committee of Direction of Fruit Marketing commitment is continuing, with the construction of a new transshipping facility at the interstate rail yard in Brisbane. This facility will be operated by COD who will, in addition to transshipping containers, also consolidate and containerise loose consignments.

References

- Jordan, R.A. 1985a. Evaluation of rail containers for transporting bananas. Qld Dept Primary Industries Report, February 1985.
- 1985b. Evaluation of rail containers for transporting bananas. III. Comparison of VSL and QRC containers. Qld Dept Primary Industries Report, November 1985.
- McLauchlan, R.L., and Jordan, R.A. 1985a. Evaluation of rail containers for transporting bananas. II. Comparison of MSL and SRC containers. Qld Dept Primary Industries Report, July 1985.
- 1985b. Experimental rail container — static temperature evaluation. Qld Dept Primary Industries Postharvest Report, August 1985.
- 1986a. Experimental rail container — transporting bananas in winter. Qld Dept Primary Industries Postharvest Report, February 1986.
- 1986b. Experimental rail container — transporting tomatoes. Qld Dept Primary Industries Postharvest Report, June 1986.

Shipment of Onions Under Ambient Conditions: Fantainers

Arthur R. Irving *

AUSTRALIAN onions have been exported for many years to the UK/European and the Southeast Asian/Japanese markets. The level of exports varied considerably from year to year (Fig. 1) depending on growing and market conditions both in Australia and in the importing country.

The recommended storage conditions for onions and their storage life varies with variety and growing conditions (Table 1). While the most common storage temperature worldwide is at or near 0°C, some Australian onions can be stored for up to a year when ventilated with air at ambient temperatures. These onions, therefore, should be able to tolerate 5–8 weeks at ambient temperature during

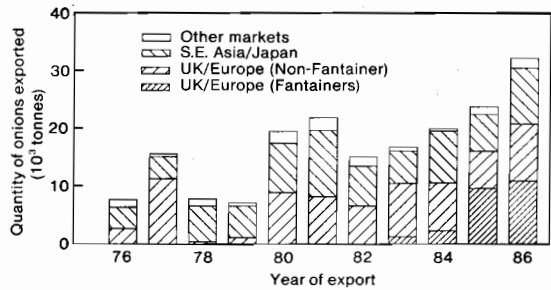

Fig. 1. Quantity of onions exported from Australia from 1976 to 1986. (Australian Bureau of Statistics: Overseas Trade Australia.)

Table 1. Recommended conditions for long-term storage of onions.

Variety/Type	Storage conditions		Ventilation changes/hour	Storage life (months)	Country
	Temperature °C	Humidity % RH			
Bessonovskij	-3 to -1	70-90	n.m.	n.m.	USSR ^a
n.m.	0	n.m.	60	n.m.	USA ^b
Globe	25 to 35				
Bermuda	0	65-70	n.m.	6-8	USA ^c
n.m.	0	65-70	n.m.	1-2	USA ^c
n.m.	up to 35	n.m.	50	6	Israel ^d
n.m.	-1 to 0	70-80	n.m.	n.m.	UK ^e
Cream Gold	5 to 15	80	20	12	Australia ^f

(n.m. = not mentioned)

^a Palilov (1971)

^b Ryall and Lipton (1979)

^c Lutz and Hardenburg (1977)

^d Felsenstein and Haas (1980)

^e Snowdon and Ahmed (1981)

^f P. Gilham (pers. comm.)

* CSIRO Division of Food Research, PO Box 52, North Ryde, NSW 2113, Australia.

shipping. The provision of adequate ventilation to keep the surface of the onions dry appears to be more important than the use of low temperature in obtaining a long storage life for some onions.

For the 2- to 3-week journey to Southeast Asia or Japan, onions are carried unrefrigerated either: (1) as break-bulk in ventilated ship's holds, or (2) in open-sided or 'flat-rack' containers stowed below deck in well-ventilated 'vehicle decks' on roll-on-roll-off (ro-ro) ships, or (3) in general-purpose (GP) containers with one door removed (i.e. 'door-off'), usually stowed on deck to catch the wind for ventilation. Apart from rain damage, the outturn from open-sided and 'flat-rack' containers is generally good, but that from the 'door-off' containers is variable.

Until the 1980s, onions exported from Australia to the UK or Europe were carried under refrigeration, either in the holds of conventional ships or in containers; the quality at outturn was generally good. However, refrigerated transport was expensive compared to the value of the onions and was not always available. Trial shipments of onions in open-sided containers from Tasmania to Europe in 1982 gave satisfactory outturns (Scrie, SRCRA, pers. comm.), but the use of 'door-off' containers on these long voyages, with accompanying large temperature changes, was not successful.

There is a reluctance by some shipping companies on the UK/Europe route to provide open-sided or 'flat-rack' containers because of their higher purchase and maintenance costs and the logistic problems in servicing a seasonal trade with special containers. As an alternative, slatted wooden pallet-bins were developed in Tasmania to transport onions in the well-ventilated vehicle decks of ro-ro vessels. These bins (Fig. 2) are about 1 m \times 1 m or 2 m \times 1 m and, when properly constructed, have



Fig. 2. Wooden pallet bins used for carrying onions in the ventilated vehicle decks of roll-on-roll-off ships.

proved to be successful. For container ships, a method was needed for adapting the readily available GP containers for the shipment of onions.

Positive ventilation is essential for onions to be carried successfully in a GP container. In New Zealand, between 1978 and 1982, different methods of providing ventilation were investigated by DSIR and the NZ Shipping Corporation (Harris and Lovegrove 1982). The final system consisted of a blower fan fitted into the top of the end wall of the container. The air left the container through vents in the bottom corners of the side walls. Good outturns were obtained in 1982 shipping trials from New Zealand to Europe, though some water-staining occurred from rainwater entering the fan inlet. The system was not taken up by the NZ Shipping Corporation because the modifications were deemed to be permanent and the containers became 'specials,' with the accompanying logistic problems. In Israel, a similar permanent modification was developed for a 'captive' trade between Israel and Europe. A blower fan was fitted into the top of the end wall, the onions were stacked on a false floor, and baffled air outlet vents were fitted to the doors at floor level; cover plates were fitted to seal the openings when ventilation was not required (Felsenstein 1982). In Australia, the 'Fantainer' system was developed by CSIRO in cooperation with shipping companies and an onion exporter (Sharp and Irving 1984). The shipping companies regard this system as a one-trip modification rather than a 'special,' as the container is restored to its original configuration at the end of the trip.

Ventilation Requirements

After harvest, onions must be cured. According to Buffington et al. (1981) 'Curing may be defined as a treatment to dry the outer surfaces and the neck of an onion. The drying results in the surface layers of onion tissue becoming less permeable to moisture flow, and more resistant to the entry of disease organisms.' During storage and transport, the surface of an onion must be kept dry to prevent fungal and bacterial rotting, and to ensure the onions keep their bright appearance. If air flow over the surface is too low, water moving from the centre of the onion will remain in the outer layers, providing conditions for rotting to occur. If the air flow is too high, the onions will lose too much water and the dry outer layers will separate ('skinning').

The ventilation rate required during storage is not

well documented and many recommendations for storage do not even mention ventilation (Table 1). Harris and Lovegrove (1982) established that New Zealand 'Cream Gold' (Pukekohe) onions could be transported successfully for periods of 6 weeks when ventilated at 30 air changes/hour. This ventilation rate also proved to be successful in an 11-week static trial using Tasmanian 'Cream Gold' onions (Sharp and Irving 1981).

In a trial shipment of onions from Tasmania to the UK in 1982, an exhaust fan, fitted into the end wall of a GP container, provided a ventilation rate of 26 air changes/hour through a pair of vents fitted into the bottom of each side wall near the doors (Sharp and Irving 1984); due to various delays, the journey took 9 weeks. At outturn, the onions were reported to be dry and firm but very dusty, the dust being from mould. The presence of dry mould indicated that the onions had become moist during the journey and the mould grew, but the onions had subsequently dried out. The temperature of the onions lagged behind the ambient temperature during the journey through the tropics and was below the dewpoint temperature of the air for several days (Fig. 3). It is probable that water condensed on the

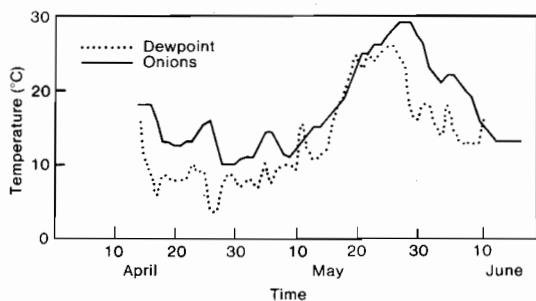

Fig. 3. Centre temperature of the stow of onions and the dewpoint of the ambient air during a trial shipment from Tasmania to the UK in 1982. (Dewpoint calculated from ship's log of ambient temperature and relative humidity.)

onions at this point and that the mould grew before the onions redried. It was calculated that the rate of temperature change of the onions could be increased sufficiently to keep them above the dewpoint temperature if the ventilation rate was increased to 35 changes/hour. This was achieved using the same fan by doubling the number of inlet vents to four in each side wall of the container.

The positioning of the inlet vents at the door end of the side walls was found subsequently to give a nonuniform air distribution. Detailed measure-

Table 2. Pressure drop per metre depth in a stow of onions in a GP container for three positions of the four inlet vents in the side walls and with a ventilation rate of 39 changes/hour (the onions, 60–80 mm diameter, were in 20-kg net bags stowed 1.8 m high).

Position of inlet vents	Pressure drop (Pa/m)			
	1/8 length ^a	3/8 length	5/8 length	7/8 length
Door end	0.4	0.4	0.8	1.1
Bulkhead end	0.9	0.8	0.4	0.2
Evenly spaced	0.7	0.6	0.7	0.6

^a Measured from end wall of container.

ments of the pressure drop at different locations in a container of onions showed that even spacing of the vents gave the most uniform pressure drop and consequently, the most uniform air flow (Table 2).

Description of the Fantainer System

The Fantainer system consists of a GP container fitted with an exhaust fan, inlet air vents and a slatted false floor.

The exhaust fan (300 mm diameter) is fitted into a hole cut into the centre of the top of the end wall of the container. The fan is wholly within the container to provide mechanical and environmental protection, but can be removed and replaced from outside if it fails. A protective grille is fitted over the fan and telltales (usually strips of coloured plastic) are fitted to indicate whether the fan is operating correctly. A ventilation rate of 35 air changes/hour (0.3 m³/sec) is required. The characteristics of two suitable fans are shown in Fig. 4.

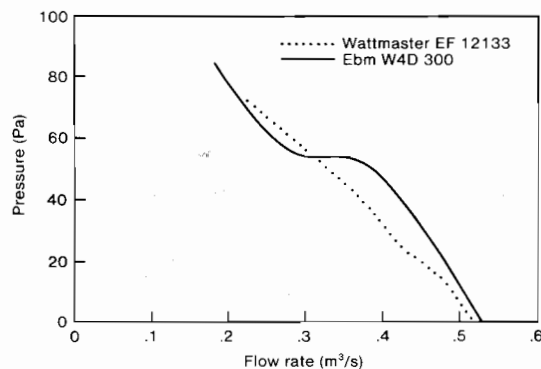

Fig. 4. Characteristics of two fans, 300 mm diameter, suitable for use with general-purpose containers.

The inlet vents can be installed in either of two ways. In the first method, four vent holes are cut into the bottom of both side walls; one vent is placed near each end of the side walls and the other two spaced evenly between (Fig. 5). Moulded plastic



Fig. 5. Fantainer showing evenly spaced inlet vents in the side wall.

building vents, 200 × 100 mm, are suitable and readily available; the interior mesh is removed and eight such vents give the required flow. In the second method, a single inlet vent is cut into the end wall below the fan and a louvre or wire mesh placed over the opening. To carry the incoming air down to floor level, either a box duct (Fig. 6) or a bulkhead

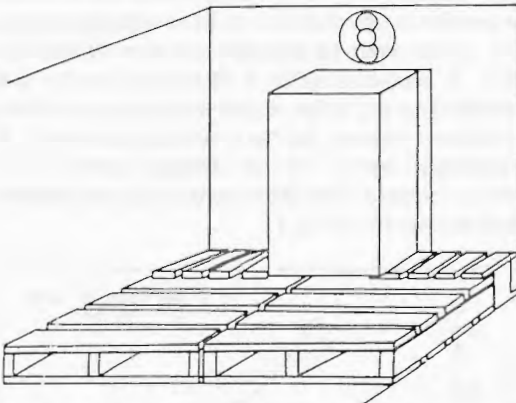

Fig. 6. Fantainer with end inlet vent below the fan and a box-duct (630 mm wide × 265 mm deep × 1540 mm high) to direct the incoming air to the floor. Also shown is a suggested arrangement of pallets as a false floor.

duct (Fig. 7) is fitted inside the container. The size of the opening depends on the type of duct (for more details see Sharp and Irving 1986).

The false wooden slatted floor is fitted to create a free space of 100 mm to distribute the air beneath

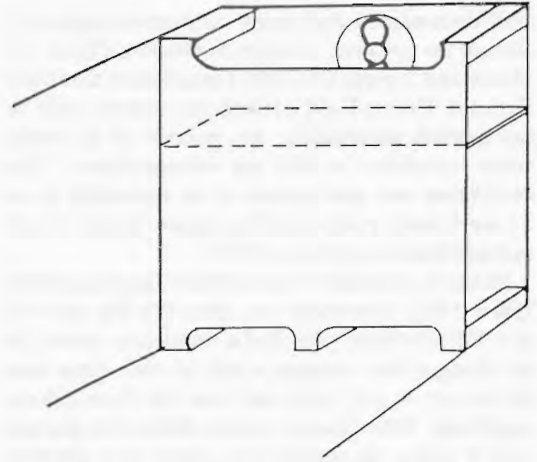

Fig. 7. Fantainer with end inlet vent below the fan and a bulkhead-duct (300 mm wide) to direct the incoming air to the floor.

the stow. The timber floor planks adjacent to the walls generally have to be tilted to ensure that air from the vents in the side walls enters the under-floor space (Fig. 8). A layer of pallets can be used

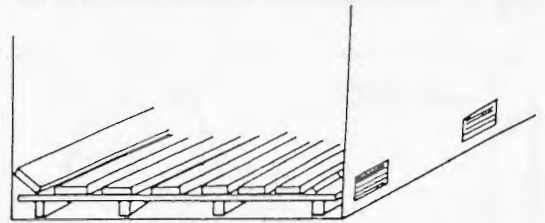

Fig. 8. Fantainer with side inlet vents showing a false floor with an additional edge plank tilted to direct air to the under-floor space.

as the floor when air enters through an end-vent, but this is not acceptable when side wall vents are used because the side rails of the pallets obstruct air movement. For containers fitted with a single end wall vent, the false floor must fit around the bottom of the duct to ensure even air distribution. In this case a layer of pallets may be used: 10 pallets 1100 mm square — a standard size in Europe — fit neatly into the container, leaving a 300-mm gap which is sufficient for the box- or bulkhead-duct.

Stowage of the Onions

Onions are usually hand-stacked into the container in net bags (commonly 20 or 25 kg,

overpacked by 1 to 2 kg to allow for weight loss). The bags are stowed lengthwise on top of each other; each container holds 12 to 14 t of onions. A gap is left in the top of the stow near the fan to avoid restricting air flow, but the rest of the stow can be stacked to the ceiling as the onion bags settle by at least 100 mm when the container is moved.

Alternatively, onions can be unitised on pallets and stowed into the containers. While savings in labour costs can be made in both Australia and the importing country, this has to be balanced against a lower payload of 10–12 t/container.

Quality of Onions at Outturn

The outturn of some fantainers has been observed each year by the Australian Horticultural Officer stationed in London. The reports on the condition of the onions ranged from fair to excellent and were comparable with onions shipped in wooden pallet bins. There were many reports of mechanical damage to the onions, indicating that exporters need to take much more care during their handling, sorting and packing procedures. Onions from some fantainers have outturned with unacceptably high amounts of wastage; most of these onions have been exported from the mainland states. However, because of the differing field conditions, many onions from the mainland are not as well cured as those from Tasmania (S. Morris, pers. comm.); inadequate curing may account for some of the poor outturns.

Conclusions

1. Most Australian onions are now exported, either in fantainers or pallet boxes, under ambient conditions instead of under refrigeration; the lower costs of transport has increased the competitiveness of Australian onions in the marketplace.

2. The ability to convert GP containers to fantainers on a one-trip basis has allowed shipping companies to provide a service without the logistic problems involved in providing special containers for seasonal exports.

3. Both fantainers and pallet boxes carried in ventilated holds may be used for exporting onions. Commercial considerations and the schedules of the shipping companies will determine which system is used.

4. Australian exporters need to give more careful attention to their curing and handling procedures to ensure that only well-cured, high-quality onions are loaded into fantainers or pallet boxes.

References

- Buffington, D.E., Sastry, S.K., Gustashaw, J.C., and Burgis, D.S. 1981. Artificial curing and storage of Florida onions. *Transactions of the American Society of Agricultural Engineers*, 24, 782–788.
- Felsenstein, G. 1982. Refrigerated transport of perishables from Israel to Europe: problems and solutions. *Refrigeration Science and Technology*, 52, 327–334.
- Felsenstein, G., and Haas, E. 1980. Long-term storage of potatoes and onions in Israel. *Canadian Agricultural Engineering*, 22, 35–39.
- Harris, S., and Lovegrove, J. 1982. The current stage of development of force-ventilated general-purpose 20' ISO shipping containers. Auckland, New Zealand, The Shipping Corporation of New Zealand Ltd and the Auckland Industrial Development Division, DSIR, 49 p.
- Lutz, J.M., and Hardenburg, R.E. 1977. The commercial storage of fruits, vegetables, and florist and nursery stocks. United States Department of Agriculture, *Agriculture Handbook No. 66*, 94 p.
- Palilov, N.A. 1971. The biological bases of onion storage. *Acta Horticulturae*, 20, 53–63.
- Ryall, A.L., and Lipton, W.J. 1979. Handling, transportation and storage of fruits and vegetables. Vol. 1, 2nd Edn., 587 p. Westport, Connecticut, AVI Publishing Co.
- Sharp, A.K., and Irving, A.R. 1981. Transport of onions in general-purpose freight containers modified for forced ventilation with ambient air. A static trial (April–July, 1981). CSIRO Food Research Report No. 154.
1984. Transport of onions in general-purpose freight containers modified for forced ventilation with ambient air. 'Fantainer trial 2,' April/June 1982. CSIRO Division of Food Research Technical Paper No. 45.
1986. Recommendations for the export of onions in Fantainers. CSIRO Food Research Quarterly, 46, 16–21.
- Snowdon, A.L., and Ahmed, A.H.M. 1981. The storage and transport of fresh fruit and vegetables. London, National Institute of Fresh Produce, 32 p.

Shipping Cocoa and Coffee in Naturally Ventilated Containers: The CSIRO Ventainer

Alister K. Sharp *

WHEN materials that contain moisture are shipped from one climatic region to another, there is always the risk of moisture damage due to moisture migration. This problem is especially important to Australia, because most of our exports travel through the tropics to cool destinations. Although containerisation has solved some shipping problems, it has increased the risk of condensation damage.

All atmospheric air contains some moisture, the amount commonly being measured as the relative humidity. The maximum amount of water that air can hold as vapour becomes less as the temperature is lowered. As moist air is cooled, it reaches a temperature, dependent on how much moisture it contains, at which it is saturated with moisture. This temperature is called the dew-point. If air is cooled below its dew-point by contact with a cool surface, the excess moisture condenses, and is deposited on the surface as liquid water. The humidity can also be calculated from the wet-bulb temperature, which is the temperature reached by a wet surface (such as a thermometer covered with a wet wick) when it is exposed to a moving stream of air. The relationships between temperature and humidity are often presented in the form of two families of graphs, called a psychrometric chart, as shown in Fig. 1. The dry-bulb temperature is the common horizontal axis: the vertical lines represent constant dry-bulb temperatures, the horizontal lines represent constant moisture contents (and dew-points), the inclined straight lines represent constant wet-bulb tempera-

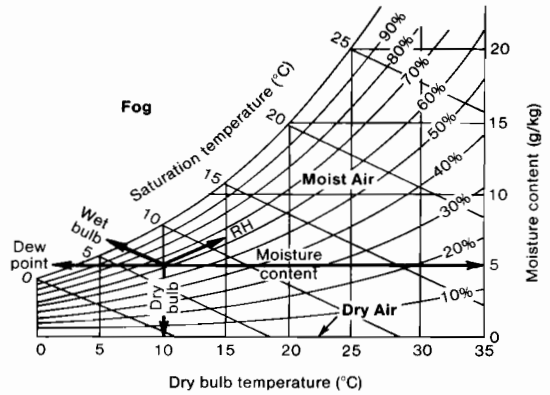

Fig. 1. Psychrometric chart, showing relationships between temperature, moisture content, and humidity of air.

tures, and each curved line represents air at a constant relative humidity.

General-purpose (GP) containers (i.e. non-refrigerated, closed containers) are relatively well sealed, and any moisture that condenses within them usually comes from the cargo itself, including the packaging materials, and not from outside air. Most 'dry' foodstuffs such as raw cocoa beans and green coffee beans contain between 5 and 15% water, as do packing materials such as paper, fibreboard, and wood. A container loaded with cocoa (11 t at 8% moisture content) is carrying 880 kg of water, and a container of coffee (13 t at 12% moisture content) is carrying 1560 kg. If only a small fraction of this water condenses and runs on to the cargo, it can directly damage the top and sides of the stow, and subsequent mould growth may

* CSIRO Division of Food Research, PO Box 52, North Ryde NSW 2113, Australia.

damage or taint the whole load. Much of the water in such materials is not permanently bound, and can exchange with water vapour in the air.

If a sample of the material were put into a closed jar, there would be an exchange of moisture between the material and the air, and the relative humidity in the jar would change until it reached a steady value. This value depends on the material and its moisture content, and is known as the equilibrium relative humidity (ERH). A material will lose water to the surrounding air if its ERH is higher than the relative humidity (RH) of the air, and vice versa. The relationship between the moisture content of the material and its ERH is termed the sorption isotherm, and sorption isotherms of cocoa and coffee are given in Fig. 2 and 3 respectively. The sorption isotherm determines the movement of water vapour in the presence of a temperature gradient.

There are two quite different types of condensation, both of which occur only when the temperature changes and when there is water available within the cargo space. Both types are discussed in a recent and comprehensive publication by the International Cargo Handling Co-ordination Association (ICHCA 1986).

'Cargo-sweat' is the condensation of moisture on the cargo itself, and occurs when a cool cargo is shipped through a warm region. Canned foods shipped from cool regions are common victims of cargo-sweat because the fibreboard packaging contains moisture, and because this cargo has a high heat capacity, and therefore warms and cools only slowly, creating long-lived temperature differences. As the ship enters the tropics, the outer part of the cargo (including its packaging) is warmed, releasing water as vapour which migrates towards cooler parts of the stow, and condenses there. Condensation causes the tinplate to rust, and permits mould growth which damages the labels and packaging. Any leakage of warm, humid tropical air into the container will increase the incidence of cargo-sweat. The problem of cargo-sweat on canned foods is discussed by Middlehurst and Parker (1978), and by Sharp (1978).

'Container-sweat' (or 'ship-sweat') differs from cargo-sweat in that it affects warm, moisture-laden cargos when they are shipped into cool regions. As the ship enters cooler regions, the walls and ceiling of the container (or hold) cool faster than the cargo within. Natural circulation of air inside the container transfers moisture from the warm parts of

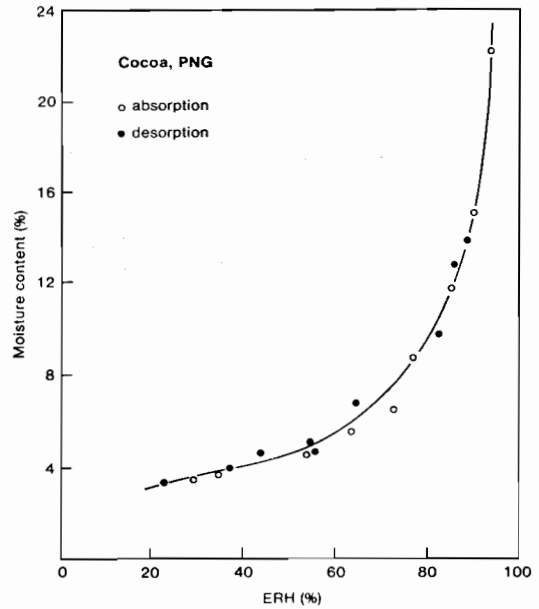

Fig. 2. Sorption isotherm of PNG cocoa, showing relationship between the moisture content and the ERH (equilibrium relative humidity) (Sharp, unpublished data).

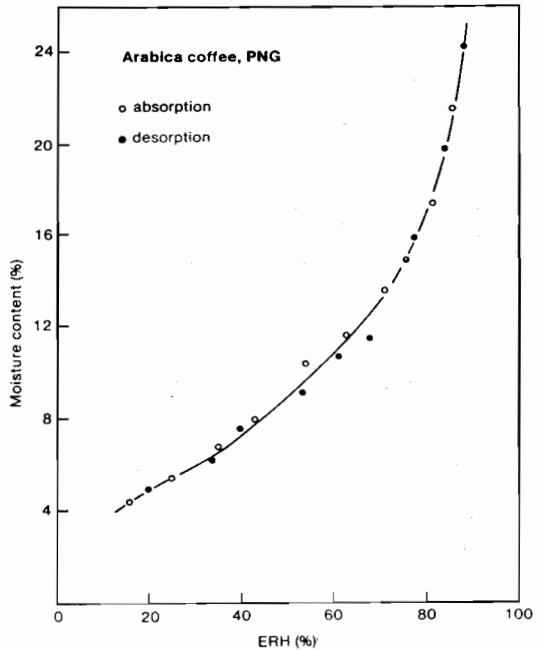

Fig. 3. Sorption isotherm of green PNG arabica coffee, showing relationship between the moisture content and the ERH (equilibrium relative humidity) (Sharp, unpublished data).

the stow to the cooler interior surfaces of the container, where it condenses as droplets. If condensation continues the drops coalesce, and water runs down the walls and rains on to the top surface of the cargo. Any commodity that contains moisture, including grains and animal feeds, can be affected by container-sweat.

Moisture can only condense within containers if there are temperature differences such that some surfaces are cooler than the dew-point of air somewhere in the container, and if water vapour can migrate to those cool surfaces. Consequently condensation can be prevented by the following measures: (i) limiting the moisture content of the cargo and its packaging materials; (ii) reducing the dew-point of the air inside the container by the use of desiccants; (iii) preventing moist air from reaching cool surfaces; and (iv) insulating the walls of the container to reduce the rate of heat transfer (for cargo-sweat), or to reduce the temperature difference between the cargo and the interior surfaces (for container-sweat).

In addition cargo-sweat is controlled by shipment in closed containers, and by warming the cargo before shipment. Container-sweat is controlled by ventilation of the load space, to exhaust the moisture before it can condense.

When shipping companies serving Papua New Guinea first proposed to introduce container ships in place of conventional ships for the export of cocoa and coffee, previous experience suggested that these commodities could be affected by container-sweat, and CSIRO was asked to advise the PNG Department of Primary Industry on how to avoid this problem. Several trial shipments were made from PNG to Australia, to Germany, and to England to evaluate modified containers, and to compare them with commercial ventilated containers intended for coffee. Based on the results of these trials, CSIRO designed and built prototype 'Ventainers,' permanently modifying steel GP containers to provide passive ventilation, and conducted sea trials. These trials are summarised by Sharp (1984).

Evaluation of Measures to Prevent Container-Sweat

Diversion of Condensate

Early investigators in the USA modified a standard container by constructing within it a

plastic-film 'tent.' The tent allowed moisture to condense on the ceiling and walls of the container, but prevented it from contacting the stow. This system was shown to be unsuitable, however, when Dutch investigators found that cocoa transported from Colombia to Europe in such a container developed musty off-flavours, attributed to microbial growth (Knobbout 1971).

Insulation

In the first trial shipment (Sharp et al. 1979), with a cargo of cocoa, a standard GP container was compared with two similar containers lined with light insulation. One was lined with building paper faced both sides with aluminium foil ('Sisalation 420,' Sisalkraft Australia Pty Ltd), and the other with 12 mm insulating board manufactured from sugar cane fibre ('Caneite,' CSR Ltd). The Caneite lining gave a better result than the Sisalation, because it absorbed some free water. However, neither system completely prevented condensation because air was able to flow through gaps between the sheets of insulation, and to circulate over the walls and ceiling. Furthermore, both systems were costly as they required extensive frameworks to support the sheets of insulation.

A later trial (Sharp 1984) evaluated heavily insulated, ventilated containers, made by fitting ventilation openings to 'porthole' containers previously used for refrigerated cargoes. The insulated walls were judged as having contributed to the absence of condensation in these containers.

Reduction of Moisture Content

In a second trial shipment of cocoa from PNG to Australia, one standard GP container was loaded with cocoa that had been dried for 2 hours longer than normal, reducing the moisture content from 8-9% to 7%. (The additional drying reduced the ERH from 75% to 65%, but currently would not be commercially acceptable because cocoa is sold by net weight, not by dry weight.) The additional drying did not prevent heavy condensation occurring in this container, and an expert panel found off-flavours in chocolate made from this cocoa. Additional drying was then abandoned as a measure to prevent condensation.

Refrigeration

The use of refrigerated containers would prevent condensation, by maintaining the cargo and the

interior surfaces at the same constant temperatures throughout the journey. The set-point of the refrigeration unit would be adjusted to the anticipated ambient temperature at the destination, to prevent condensation at outturn. Unfortunately the freight rates for cocoa and coffee are low for historical reasons, making the use of refrigerated containers too expensive, and we are not aware of any trial refrigerated shipments.

Desiccants

Silica gel, activated clay and activated alumina are commonly used as desiccants to protect nonhygroscopic cargoes such as machinery. Wood (1977) refers to trial shipments of cocoa in which quantities of silica gel of from 25 to 200 kg were placed in each container to reduce the humidity. Silica gel will absorb up to a third of its own weight of water, but will release this water again at high temperatures. Although it appeared that the level of condensation was reduced, not even 200 kg of silica gel (which would absorb 66 kg of water) completely prevented condensation.

Impermeable Packaging

Cocoa and coffee are shipped in jute bags holding 60 kg and 63 kg respectively. If a plastic liner were fitted in each bag, moisture could not leave the bag, and could not condense on the ceiling and walls of the container. In trial shipments of cocoa from Ghana and Nigeria to the UK, Wood (1977) found that polyethylene bag-liners prevented practically all condensation at little added cost, but the cocoa industry was too conservative to accept this innovation.

The widespread use of Kraft paper (i.e. wrapping paper) in GP containers carrying coffee from South America and PNG is probably based on its ability to limit the internal circulation of air. Before the container is loaded, the floor and walls are lined with paper, which probably serves only to keep the cargo clean, and a layer of paper is placed over the stow, which undoubtedly would limit air movement. However in several shipping trials conducted by CSIRO, such use of Kraft paper did not affect the incidence of condensation.

Ventilation

The holds of most conventional ships are ventilated whenever considered advisable by the ship's personnel. On some ships this is accom-

plished by wind action, and on others with the assistance of fans. In heavy weather, or when the ambient humidity is higher than the humidity in the hold, ventilation can be stopped. Ventilation of individual containers is more difficult. It is possible to envisage a fan-ventilation system for containers, either from a central source, or using a fan mounted in each container (such as the 'Fantainer' concept developed for onion shipment: Irving (these Proceedings)) but this would be more expensive than a system that relies on natural ventilation. Early trials (Wood 1977) showed that passive ventilation that relied on manually operated vent openings did not work simply because the vents were not opened and closed at the correct times. It was decided, therefore, to investigate passive ventilation systems, using fixed, weather-resistant vents.

Requirements of a Passive Ventilation System

At the start of the project several commercial passively ventilated containers were in production, but none met all of the requirements we considered important for PNG, which were:

(i) It should be possible to convert existing general-purpose containers, and the conversion should require no specialised equipment, so that containers could be converted as required, in PNG or any other exporting country;

(ii) The free vent area should be large (at least 0.25 m²) to permit a high rate of ventilation;

(iii) The vents should not change the external dimensions of the container, which are standardised, or the internal dimensions, which would reduce the available volume for cargo;

(iv) Because of the strict quarantine regulations regarding the cleanliness of containers entering PNG and Australia, the vents should be able to be easily cleaned and inspected, and must not incorporate enclosed spaces which might harbour insects;

(v) The modifications must not weaken the container, and the vents themselves must be sufficiently robust to withstand normal use (sheet metal louvres are too easily damaged);

(vi) The vents should be water-tight within the meaning of the relevant ISO standard;

(vii) The interior faces of the vents should be designed such that no dunnage or special stowage

pattern is required to prevent obstruction to air flow;

(viii) Water should drain freely from the vents to the exterior, so as to minimise the opportunities for corrosion.

Mechanisms of Passive Ventilation

The rate of air flow through the ventilation openings fitted into a container depends on the total area of the vents, and also on the distribution of the vents over the surface of the container, on the shape of the vents, and on the airflow resistance of the stow. Two modes of passive ventilation are possible:

(i) *Wind ventilation*, which involves the cross-flow of air through openings fitted in opposite sides of the container, is driven by the velocity head of the wind. Since wind velocity increases with height above the ground, wind ventilation is aided by fitting vents near the top of the side walls with equal vent areas on opposite sides of the container. The ventilation rate is approximately proportional to the wind speed.

(ii) *Chimney ventilation*, which involves the vertical flow of air through vent openings fitted at different heights, is driven by the buoyancy effect (density difference) which depends on the temperature difference between the interior and exterior of the container, and on the vertical distance between the vents. Chimney ventilation is aided by fitting equal vent areas near the bottom and near the top of the side walls. The direction of chimney ventilation depends on whether the interior of the container is warmer than the surrounding air, or cooler, and the rate of ventilation is proportional to the square root of the temperature difference, so that even a temperature difference as small as 1C° can produce a ventilation rate of 1 air change/hour in a container with a vent area of approximately 0.3 m^2 (Heap 1983).

Wind ventilation can operate only when the container is exposed to moving air. Below deck, or ashore on a windless night, wind ventilation is ineffective, yet it is in just such still conditions that condensation is most likely. Wind will keep the surface of the container at the same temperature as the air, which is rarely more than a few degrees below the stow temperature. The condition most likely to cause container-sweat is when the container is exposed to a clear sky on a still night, when the roof may be substantially cooled by

radiation. Chimney ventilation is particularly effective because it is driven by the same temperature difference that causes condensation, and is greatest on a clear night when the risk of condensation in a nonventilated, or wind-ventilated, container is highest.

'Ventainer' System of Passive Ventilation

Ventainer is based on the standard steel GP container produced in many countries, and in use throughout the world. 'Pocket' type vents are formed by cutting openings into the castellations of the side walls (see Fig. 4), with equal numbers near

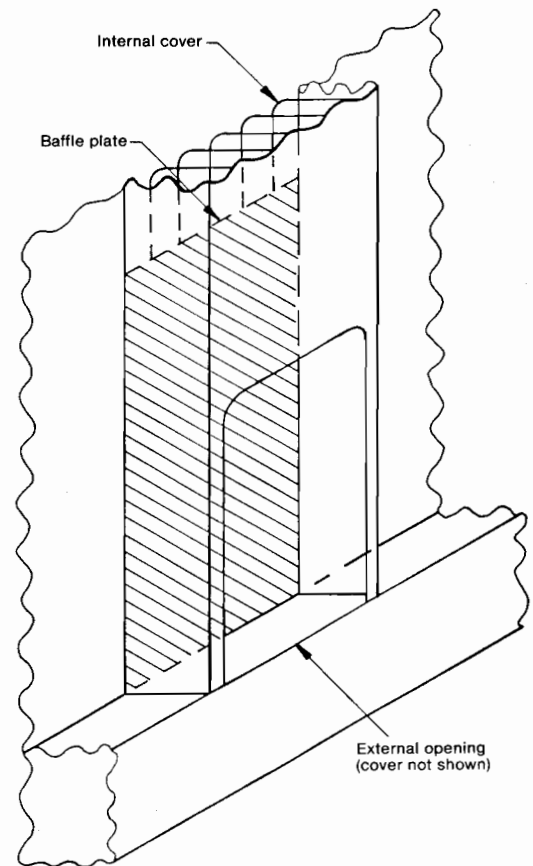

Fig. 4. Details of the 'pocket' type vent used to convert standard general-purpose containers to Ventainers (free area per vent = 0.0035 m^2 , total vent area approximately 0.28 m^2). One vent is fitted at floor level to the outward face of every castellation in each side-wall, and one to each inward face at ceiling level.

floor level and near ceiling level. These openings are backed with welded baffle plates which prevent the entry of water, and also compensate for strength lost in making the openings. Heavy perforated metal plates cover the exterior openings to help break up the water jet stipulated for the waterproofing test, and exclude rodents. The interior openings of the

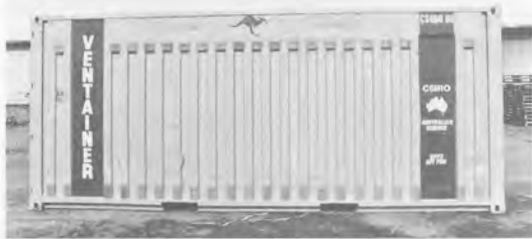

Fig. 5. The CSIRO 'Ventainer' ventilated container.

vents are covered with coarse mesh. This prevents cargo from falling into the vents and obstructing the air flow, without hindering cleaning or quarantine inspection. The ceiling of the container is lined with plywood, which acts as light insulation, and also, if there is condensation, diverts the runoff to the walls. A prototype Ventainer is shown in Fig. 5.

Comparison with Commercial Ventilated Containers

Many container manufacturers have constructed prototype, and production model ventilated containers. The first special containers for cocoa and coffee used large, manually operated vent covers but later models had fixed, baffled openings, relatively small in total vent area ($0.1-0.2 \text{ m}^2$), and usually consisting of perforations in the top and bottom structural members of the container. Some also incorporated jacketed walls or internally-baffled vent units built into the walls. All these systems create inaccessible spaces that are unacceptable for quarantine inspection, and most of these designs concentrated the vent area towards the top of the walls for wind-ventilation. One company modified surplus porthole insulated containers by fitting sheet-metal louvred vents into the walls, with equal areas at floor and at ceiling level, for chimney ventilation. These, too, cannot be inspected for quarantine clearance, and the louvres are easily crushed, restricting air flow. Only one commercial design (Sea Containers Sea Vent MkIII) meets most

of the design requirements listed above, failing only to provide unobstructed interior vent openings.

Experimental comparisons, involving side-by-side trial shipments to Australia and to Europe (summarised by Sharp 1984) have shown that Ventainer, and the one commercial ventilated container with similar vents, prevent container-sweat under most conditions, and under very severe conditions permit only light condensation which does not affect the quality of cargoes of cocoa or coffee.

Suitable Cargoes for Naturally Ventilated Containers

Naturally ventilated containers, such as Ventainer, are suitable only for cargoes subject to 'container-sweat,' i.e. for warm, moisture-containing produce shipped to a cool region. As well as for tropical produce such as cocoa, coffee, copra, ventilated containers are suitable for high-moisture grains and animal feeds (such as pelleted lucerne). Naturally ventilated containers are not suitable for live produce such as onions because they provide only moderate rates of ventilation. Neither are they suitable for produce such as potatoes that require refrigeration for protection from high temperatures.

References

- Heap, R.D. 1983. Naturally ventilated containers for the carriage of hygroscopic cargoes. Proceedings of the XVth International Congress of Refrigeration, Paris 1983, IV, 375-381.
- ICHCA 1986. Condensation in containers. London. International Cargo Handling Co-ordination Association.
- Knobbout, J.A. 1971. Maritime transportation of containerized cargo. Part II: Experimental investigations concerning the carriage of green coffee. Netherlands Ship Research Centre, TNO, Report 149M, 13 p.
- Middlehurst, J.M., and Parker, N.S. 1978. Prevention of condensation on canned foods in ISO containers. CSIRO Food Research Quarterly, 38, 25-34.
- Sharp, A.K. 1978. The prevention of 'sweat damage' to canned food products shipped in containers. Food Technology in Australia, 39(3), 89-93.
- 1984. Preventing container sweat. Cargo Systems International, 11(3), 58-67.
- Sharp, A.K., Fenner, T.L., and van S. Greve, J.E. 1979. Prevention of condensation damage to cocoa beans shipped in containers. Journal of Stored Products Research, 15, 101-109.
- Wood, G.A.R. 1977. The transport of cocoa beans in containers. Cocoa Growers' Bulletin, 26, 21-23.

Bulk Shipment of Oranges in Refrigerated Containers

Barry L. Tugwell *

THE Western Australian Department of Agriculture successfully exported 15 containers of bulk-loaded Granny Smith apples to England during the period 1979 to 1982. This was followed by a bulk shipment of loose onions from Tasmania to Belgium in 1980.

A weight of 17.7 t of produce is permitted in a standard refrigerated container. A stow of 518 tray pack cartons of apples weighs only 9.25 t. By using the 'Hardisty' bulk bin the stow can be increased to 10.8 t, and when bulk-filled the capacity achieved was 13.5 t. A load of 12.4 t of bulk Cream Gold onions was exported to Belgium in 1980.

The trial shipments were satisfactory but due to low prices no further bulk shipments were sent after 1981.

A container stowed with C6 cartons of oranges will usually hold around 600 packages weighing in total 12 t. A bulk-filled container of oranges could be expected to hold an additional 2-3 t of fruit.

A duty of M60 cents/kg is charged on imported fruit arriving in Malaysia. The Malaysian government is willing to waive 50% of this duty if some local packing takes place in Malaysia.

A cost saving of over A\$2 per package of fruit can be expected due to increased stowage efficiency and reduction in duty.

Fruit handling facilities are available at the FAMA cool store complex on the Malaysian mainland near Penang.

An experimental consignment of oranges filled into bulk bins was sent to Chop Tong Guan Sdn.

Bhd., Penang, during December 1985. This enabled the importer to gain experience in packing bulk fruit and provided the necessary bulk bins for unloading and storage of fruit from bulk-filled containers.

The equipment used for bulk filling of containers with apples was obtained on loan from the WA Department of Agriculture.

Filling the Container

Fruit Preparation

Count 162 Leng Navel oranges were treated with 1000 ppm Benlate(R) (double normal concentration) in addition to normal fungicide and waxing treatments.

The fruit was accumulated in 0.5-t bulk bins and held at ambient temperature (13°C) prior to loading. The fruit was in good condition but some of the finer-textured fruit showed slight albedo breakdown.

Loading Equipment

The loading equipment (Fig. 1) consisted of a hydraulic bulk bin tipper and a 38 cm wide belt conveyor operated as a swinging boom. Technical drawings of the equipment may be obtained on request from the author. The boom was originally attached to the lifting bar of a small forklift which moved into the container during the filling operation. The system was designed for operation from a loading dock which was not available at Waikerie Co-op. The first bulk container required considerable effort to fill because the conveyor reached only 3.5 m inside.

* Senior Research Officer (Post-harvest Horticulture), South Australian Department of Agriculture, Northfield Research Laboratories, Box 1671 GPO, Adelaide SA 5001, Australia.



Fig. 1. Conveyor filling container with oranges.



Fig. 2. Bulkhead boards being fitted into channels in doorway.

Floor

Polystyrene sheeting 25 mm thick was placed on the floor. Ventilation holes 50×25 mm spaced 150 mm apart across the container were cut in the styrene sheeting. The rows of holes were repeated every 300 mm down the length of the container.

Containers with 75 mm air channels down each side of the container may require a 150 mm wide strip of masonite or plywood to support the false floor. The container used in this trial did not require such modification.

Bulkhead (False Door)

The bulkhead was constructed from steel channels fitted with brackets to slip over lashing points just inside the door. Nylon plugs can be used if lashing points are not provided. Hardwood planks finished to 25 mm thickness were fitted into the channels. The bottom three boards were bolted so that they could be removed from the outside. The other boards were slipped into the channels during filling (Fig. 2).

Loading the Container

The first container was loaded at Waikerie Co-op on 26 June 1986. It took 6 hours to load, and because of the short conveyor considerable quantities of fruit were moved by hand. The fruit was filled to within 150 mm of the roof of the container. It is possible to fill to within 50 mm of the roof.

The container was filled progressively from the rear using a temporary wooden baffle to prevent fruit from moving to the front of the container (Fig. 3).

The container MAJV 870 0460 was filled with $700 \times C6$ packages of count 162 Leng Navel oranges. The total weight of fruit loaded was 14.7 t. Normally around 600 packages weighing 12.6 t are loaded into a container.

Two temperature recorders were placed in the container, one fixed to the left side of the roof half way between the door and the refrigeration unit, and the other placed against the bulkhead at the bottom of the container. The printed face of this recorder was placed against the side of the container to pre-



Fig. 3. Temporary baffle inside container.

vent the pressure from the fruit jamming the recorder.

The container was loaded aboard the Bunga Seroja which sailed from Adelaide on 27 June 1986.

Unloading the Fruit

Unloading Equipment

The hopper and motorised conveyor bin filling system used in the United Kingdom for unloading bulk apples was not available. A simple hopper was designed to allow filling of two bins at a time from the tilted bulk container (Fig. 4). A drawing of the equipment was forwarded to Koay Bros., Penang, to enable fabrication of the equipment prior to the arrival of the bulk container of oranges.

On arrival in Penang the unloading equipment was inspected. Handles were fitted to the flap on the outlet of the hopper to enable the flow of fruit to be effectively controlled. Large plywood 'creep boards' were made to break the fall of the fruit flowing into the deep bulk bins used for unloading.



Fig. 4. Simple hopper for unloading bulk oranges.

Unloading the Container

The container arrived at Penang on 14 July 1986 and was delivered to the FAMA cool store complex near the town of Bukit on the mainland of Malaysia on the morning of 15 July 1986.

The container was delivered on a trailer fitted with a hydraulically operated tilting frame to allow the container to be tilted during unloading.

The first door on the container was opened to check the bulkhead. The second door was then opened and locked back.

The hopper was positioned against the rear of the container and roller conveyors placed on the ground to allow bulk bins to be moved away after filling.

The bottom two boards of the bulkhead were removed to allow the fruit to flow on to the hopper. The container was tilted to an angle of 30° to assist the flow of fruit.

The filled bins of fruit were immediately loaded into the adjacent coolroom and held at 10°C.

When two-thirds of the fruit had been removed from the container all of the bulkhead boards were removed, and it was necessary to get into the container to dislodge the remainder of the fruit. It took 3 hours to unload the container.

Fruit Condition

On arrival in Penang the fruit in the container had settled by about 15 cm to about 30 cm from the roof of the container.

The lower boards of the bulkhead bowed about 25 mm under pressure from the fruit, causing the boards to be a little difficult to remove.

Fruit temperature was 10°C, and the temperature

recorders indicated a uniform temperature of 9°C at the top and bottom of the stow.

Some fruit distortion was evident at the bottom of the stow and some of the fruit showing albedo breakdown had split (Fig. 5). The split fruit remained dry and intact.



Fig. 5. Some fruit distortion was evident in the bottom of the container.

Mould wastage was minimal, with equal quantities of sour rot and penicillium. Spoilage from spores was not a problem.

Total wastage after the fruit was packed was 355 kg, equivalent to 17 boxes of fruit or 2.4% of the consignment. Wastage in a similar bulk shipment to New Zealand was 3.3% of which 2.5% was due to sour rot.

Since the initial trial shipment over 30 containers of citrus have been sent to Malaysia and New Zealand.

Conclusions and Recommendations

1. The bulk shipment of loose oranges in a refrigerated shipping container is feasible.

2. The commercial success of bulk shipment is dependent on the availability of suitable packing and handling facilities overseas and adequate cost savings to provide sufficient incentive to market bulk lines of fruit.

3. Proper fungicide treatment and careful handling is required to ensure mould wastage and spoilage is kept to a minimum. Double strength Benlate(R) is recommended.

4. Leng Navel oranges with albedo breakdown are subject to splitting under pressure; only selected early-season fruit should be exported.

5. The polystyrene floor performed well and only slight compression occurred. The styrene thickness can be reduced from 25 mm to 12 mm as used for bulk shipment of apples.

6. The conveyor used for loading the fruit should be extended to 4.75 m to allow complete and more efficient filling of the container.

7. The bulkhead worked well with steel channels fitted with brackets which slipped over lashing points just inside the door. Nylon fasteners should be used to secure the channels if lashing points are not provided.

8. At least two removable boards should be provided in the bulkhead, to allow the fruit to flow freely.

9. Studs rather than nuts with wing-nut type heads will assist with the removal of the boards against the pressure of the fruit.

10. Transport trucks with hydraulically operated tilting frames should be used for unloading the fruit. An angle of 30° was required to assist the flow of fruit.

11. Safety chains were not required. The first door was opened to check the bulkhead for security, then both were opened and locked back prior to tilting the container.

12. The safety signs fitted to the door disappeared during transport. A self adhesive plastic label stating 'Bulk Fruit, Open First Door Carefully and Check Bulkhead for Security Before Opening Second Door' should be provided.

13. The simple hopper and creep board system used for unloading worked well. A metal flap should be provided to slip between the false styrene floor and the floor channels of the container to direct the fruit on to the hopper. Thicker plywood or heavy gauge aluminium should be used for the creep boards. The three-ply used bowed under pressure of the fruit as it ran into the bins.

14. It has been suggested that the time taken to

fill the container could be reduced by building a conveyor more suited to oranges and tilting the container during loading. The cost of the bulkhead can be reduced by using softwood boards for the top half of the container doorway.

15. It is recommended that bulk shipment of loose oranges be approved by the Department of Primary Industries for markets in Southeast Asia and New Zealand.

Acknowledgments

Appreciation is expressed to Rivsam for paying the cost of travel and accommodation to assess the

outturn of the bulk consignment, and to Koay Bros., Penang, for assisting with assessment of the fruit when it arrived in Penang.

References

- Brown, D.H. 1980. Bulk containerised onion trial Tasmania to Belgium. Acta Report.
- Hardisty, S.E. 1981. Container stowage efficiency. Western Australian Department of Agriculture Division of Horticulture Report.
- Husband, R.M. 1979. Bulk containerised apples trial W.A. to U.K. Acta Report.

Use of Refrigerated Containers to Transport Fruit and Vegetables in Papua New Guinea

Garth Atkinson * and Kevin Scott **

PAPUA NEW GUINEA (PNG) is situated between 1° and 12° south of the equator. Although its climate and vegetation are essentially tropical, temperate crops are successfully cultivated above 1000 m and up to 2000 m. Rainfall varies considerably from 1000 mm on the Lowland south coast to over 6000 mm in Western and Gulf provinces, whilst the Highland areas typically average about 2000 mm. There are two seasons, wet and dry. The Lowland central province and the Markham valley experience an extreme dry season.

The country is divided into 19 provinces, with approximately one-third of the population living in the Highland provinces. The capital, Port Moresby, has a population estimated to be between 120 000 and 150 000. It is situated on the south coast and has no road connection to the Highland areas or the north coast. The second largest urban centre, Lae (population approximately 60 000) is situated on the north coast and is connected to the Highland provinces by road. During the colonial period the expatriate population rose to a peak of about 50 000; it has declined steadily since the Second World War, to its present level of about 25 000. Most of these expatriates are now located in the urban centres.

Traditional crops of sweet potato, taro, yams,

bananas and cassava have been cultivated at subsistence level for centuries. In the nineteenth century missionaries and plantation owners introduced many temperate crops into PNG. To encourage horticultural production, the Australian colonial administration maintained a low profile food crop research program through four major research stations and various substations.

In 1973, as a result of a growing dependency on imported fruit and vegetables, particularly in the urban centres, the government set up the Fresh Food Project, as a branch of the Department of Primary Industry. The function of the project was to stimulate production and set up a transport and marketing structure for horticultural produce.

Bureaucratic difficulties experienced in attempting to operate a free trading organisation within a government department led to the formation of a parastatal organisation called the Food Marketing Corporation (FMC). This organisation had buying centres in the Highland towns of Mount Hagen, Goroka, Kainantu and Wau, and wholesale depots in Lae and Port Moresby. It also operated a fleet of refrigerated trucks.

A policy of buying local produce at low prices, regardless of quality, to stimulate production and to remain competitive against imported foodstuffs, resulted in very high operating losses (approximately K400 000 in the last year of operation). Following a government directive the organisation was dissolved in December 1981. The transport fleet, depots and facilities in the Highlands were sold off to private enterprise and utilised for other purposes. The wholesale depots in Lae and Port Moresby

* Department of Primary Industry, PO Box 417, Konedobu, Papua New Guinea; present address: ACIAR, GPO Box 1571, Canberra ACT 2601, Australia.

**New South Wales Department of Agriculture, C/-CSIRO Division of Food Research, PO Box 52, North Ryde, NSW 2113, Australia.

were sold off to the local Morobe and Central Province Governments respectively.

Concern at the indifferent attitude of private enterprise to the local horticultural industry led the Government to introduce a policy in 1983 which required traders to purchase K1.00 of local produce for every K3.00 they wished to import. In 1985 this ratio was reduced to 1:2, and at the beginning of 1986 a number of items, including tomatoes, were banned from importation into PNG. Whilst it is acknowledged that these rather draconian measures have been necessary to protect the industry in its development phase, the Department of Trade and Industry have indicated the local industry should become competitive and self-reliant within 3–5 years.

The protective legislation appears to have been effective in stimulating private enterprise investment in the horticultural industry, since over the last 2 years considerable progress has been made towards food crop self-sufficiency. Many importers now use less than their allocated quotas. Relatively high prices for imported crops have resulted in several attempts at large-scale commercial production, particularly in the Port Moresby area. However, many of these enterprises have failed, mainly because of the high costs related to short-term investment, disease and pest problems and an unprofessional approach to postharvest requirements, transportation and marketing. Recently there has been a shift in emphasis from large-scale commercial production to subsistence farming as the major source of vegetables for the wholesale market. Surprisingly this method of production has resulted in an improved continuity of supply as well as lower production costs.

Postharvest Problems in Papua New Guinea

Harvesting

Shortage of cash often prompts farmers to harvest crops prematurely. It has been observed that many lettuce offered for sale were harvested before they had formed solid heads, whilst potatoes are not given sufficient time to dry before storage and transport.

Conversely, as produce is often sold by weight and not quality, producers will often delay the time of harvest to allow crops such as English cabbage and carrots to attain greater size. This creates prob-

lems associated with overmaturity and increased susceptibility to fungal and bacterial rots.

For producers consigning vegetables by either refrigerated container or aeroplane, harvesting may be limited to 1 day/week. This often results in some of the crop being harvested when immature or overmature. Traditional crops have never required the people to develop the idea of a harvest maturity index, or even an understanding of storage techniques and marketing, since crops are harvested as required. The notion that only 60–70% of a crop may be marketable is unacceptable to people who are very conservative in their farming methods. The result is very mixed quality of produce.

Lack of fertilizer, preharvest treatment for pests and diseases and poor water management all have considerable effect on product quality at harvest.

Packaging and Handling

A major problem identified as existing throughout the distribution system was lack of adequate packaging and handling facilities. There is no packing house in PNG that has been designed specifically for packing vegetables. Even relatively well-established commercial growers pack produce outside, on the ground and with no washing or draining facilities. Rotting or decayed produce is not always removed quickly from the packing area, which encourages the spread of postharvest rots. Even though much of the produce is being packed into well-designed cardboard boxes, the boxes themselves become wet and dirty under the primitive packaging conditions.

Packaging is often in short supply, creating a tendency to overfill boxes. Physical damage, bruising, etc., was evident on almost all produce on outturn. Generally products were not adequately protected from water loss or bruising during handling, stacking and transportation.

Transport and Distribution Chain

Fruit and vegetable marketing in PNG is perhaps unique in the Pacific in that commercial production and distribution have, until recently, been confined almost exclusively to nonindigenous crops, while staple crops, which are produced by subsistence farmers, are sold through the traditional open market.

The cool climatic conditions of the Highlands ensure that the main Highland centres of Mount Hagen, Goroka and Kundiawa are well supplied with temperate vegetables, which are sold through

the traditional markets. Similarly Lae, which has good road links with the Highland areas, receives most of its fresh produce from farmers who prefer to transport it in small trucks and sell direct to buyers.

Problems arise in lowland centres such as Port Moresby, Arawa, Rabaul, Madang and Wewak, which do not have road access to high altitude areas and where local growing conditions put excessive demands on the technical skills and social activities of the people. In spite of considerable efforts in horticultural extension, local production is poor and buyers in these centres find it easier to get supplies from the Highlands than from local environs. However, this requires a good system of postharvest handling and transport if produce is to reach the markets in good condition.

The usual means of transporting crops from the Highlands has been aircraft. However, delays in off-loading of produce, lack of produce temperature control and subsequent rough handling, plus constant rerouting of aircraft, have resulted in substantial losses.

Once it reaches the main urban centre, produce is sold by private treaty to institutions and hotels, and to wholesalers who are usually retailers as well.

ACIAR Project

The ACIAR Transport and Handling Project was initiated to examine the use of refrigerated containers to transport mixed loads of vegetables. The purpose of utilising refrigerated containers was to overcome two major problems associated with postharvest losses:

Handling A marketing survey in 1981 estimated that produce grown in the Highlands and transported to Port Moresby by truck and aeroplane was involved in 31 different handling operations. The use of sacks and thin-walled corrugated cardboard boxes for packing produce, especially cauliflower, cabbage and lettuce, results in inadequate protection of the product from excessive handling and vibration bruising during transport.

Field Heat Even in the cooler Highlands field heat can be excessive. Pulp temperatures of tomatoes being packaged on the ground at Goroka were measured as high as 40°C. In general cool stores are located only in the urban centres, so there is little opportunity for the farmer to precool produce before transport, an essential step even for short aeroplane trips.

The use of a refrigerated container to transport produce reduces the number of handling operations

and provides the opportunity to precool before shipment.

The project was developed in three phases:

Static Trials Use of the container to precool eliminates both extra handling steps and the requirement to construct expensive coolrooms. The aim of the static trials, which were conducted at Goroka, was to establish cooling times for different types of produce at increasing loading rates and to evaluate the performance of the container in maintaining temperatures for periods of up to 3 weeks. A dual-temperature Email 3200 bottom-delivery container, loaned to the project by Brambles Ltd, provided the opportunity of maintaining two different temperature regimes: 8–10°C for the storage of chill-sensitive lines such as beans, zucchini, capsicum, tomatoes and potatoes: 0–4°C for lettuce, broccoli, cauliflower, cabbage, spring onions. Harvesting and packing were carried out between 6 am and 10 am. Core temperatures of produce before loading were measured at between 20 and 24°C. With 2-t loading rate using English cabbage, cooling to 4°C was completed in 24 hours. A shorter time interval was obtained for the 10°C side. Cooling rates for other types of produce and different load compositions did not vary significantly from this. Different stacking techniques did make a considerable improvement, with loose stacking giving the best result. Rapid precooling prevented the development of postharvest diseases, in particular *Erwinia carotovora* (soft rot) in lettuce, which had previously failed to respond to standard recommended chemical treatments, and *Alternaria brassicola* on cauliflower curds. The development of *Xanthomonas campestris* pv. *campestris* (black rot) was also retarded.

With relatively high air flow rates (in excess of 1500 ft³/min) and low relative humidity (55–65%), weight loss and shrivel (10–20% in lettuce) was a problem with storage times of 14–21 days. Modifications to the container, which included use of wet hessian and returning the defrost water along the floor, raised the relative humidity to approximately 80% with a subsequent improvement in quality of the produce. Perforated polythene bags were also very effective in reducing loss; however, produce placed in bags needed to be cooled immediately or there was a tendency for rots to develop.

Transport Trials Mixed loads of vegetables were loaded into a refrigerated container and pre-cooled at rates not exceeding 2 t/24 hours. Total loads of between 4 and 8 t, depending on the availability of supplies, were used for the transport

trials. The containers were loaded in Goroka, taken by road to Lae, and shipped to either Kieta (Bougainville) or Port Moresby. Road transit time from Goroka to Lae was approximately 6 hours, during which time the produce was not under refrigeration as neither the container nor the truck had generator capacity. Air temperatures in the container during this period rose to 18–24°C, although produce temperatures seldom reached higher than 6°C. Shipping times from Lae to Kieta and Port Moresby averaged about 5 days.

Delays in loading and unloading often meant the container was left off the power supply for up to 18 hours.

After this period of time the leaves of susceptible lines such as lettuce and chinese cabbage were becoming senescent, while broccoli with a very high respiration rate was showing signs of bud burst. Temperature recovery was rapid when the power was reconnected providing the container was well packed and had adequate ventilation.

Technology Transfer The third phase of the project has involved the transfer of technology to the private sector. In 1986, the New Zealand Government under its Aid Programme to Papua New Guinea funded the hire of 10 containers for a 12-month period to assess the commercial viability of containerised transport. This trial period was considered necessary to give producers and buyers time to adapt to the new technology and the logistical problems involved. In April 1987, the private sector became fully responsible for the containers, with the Department of Primary Industry continuing to have a monitoring role and providing technical assistance. The containers are currently being utilised by the Wabag Vegetable Marketing Depot (WVMD), Enga Province, and Hoveku Farms Limited at Goroka in the Eastern Highlands Province.

Conclusion

The introduction of the import quota and ban has greatly increased the volume of local production,

most of which comes from the Highland areas. In simple logistic terms it would not have been possible to air-freight this increased quantity, so an alternative system had to be devised. At present approximately 20 t/week are transported by container to Port Moresby and the Island centres of Rabaul and Kieta, and it is anticipated that this will increase by 5–10% per year.

However, there is still a requirement for the flexibility of using aircraft for the less-bulky, high-value items, providing improved methods of handling can be introduced. There are still problems with the container system: for example, because of the small market size it is often necessary to use mixed loads of produce which have incompatible temperature requirements. Different lines need specialised packaging, which makes regular stacking difficult, and subsequent movement during transit reduces air flow and cooling. The lightweight construction of the containers has made them vulnerable to vibration damage on the unsealed sections of the Highlands highway.

Although it is recognised that the use of refrigerated containers does not solve all the problems, it has made a large impact on the industry. The value of the produce currently being transported by container is estimated at approximately K1.0 million. Most of this is coming from smallholder farmers in places like Enga which do not have access to airfields. The other obvious benefit is that the container system halves the freight cost.

A marketed fruit and vegetable project, designed and implemented by the Department of Primary Industry in 1986, aims to improve extension services and to build packing houses in the production areas and wholesale markets in the urban centres of Lae and Port Moresby. These facilities, which will further increase the volume of produce being marketed, are being designed around the transport system.

Design of Packages for Fruit and Vegetables for Transport by Sea or Land

I.D. Peggie *

It is important to approach this subject without preconceived ideas. Packaging to most people denotes a neat, rectangular carton, but, for some produce going to a particular market it may well be that no package in the usual sense of the word is necessary. Western Australia's efforts with bulk shipments of loose Granny Smith apples in a sea container deserve much more support than they received from either their own industry or from the importers. On the other hand, a lot of success is currently being achieved with export of consumer packs, say of strawberries and grapes. This is maximising the added value in Australia.

Transport facilities are quite variable. Rectangular seafreight containers are ideal, except for variations in length, height and width that different manufacturers introduce. Conventional ships can cope with all package shapes and sizes, provided the stower can put up with awkwardly placed pillars, uneven floors, sloping sides, and masses of timber dunnage. And it is the package handlers who drop, throw, stack on end, walk on and kick packages, and thereby create packaging problems. On land, road freight dominates, but Australian truck widths and load limits are different to those of other countries.

The usual process in package design for fresh fruit and vegetables is as follows: the grower dreams up a version of an ideal package, persuades some company to manufacture it, fits the produce into it, and then leaves all the problems of transport and marketing to somebody else. However, in the interests of good marketing this sequence of events should be reversed.

There are four major areas to be considered in the initial stages of produce packaging design. In what I believe to be the most important priority order, we should consider the requirements of the market, the produce, the transport system and finally the producer, as follows:

Market Requirements

Produce Protection

Will the produce arrive in good condition? Importers may be able to cope with gluts, weather changes, even odd varieties or unusual fruit sizes, but they cannot sell damaged produce. Combined effects of bruising, abrasion, high temperature, wetness, rots and other factors render produce almost unsaleable, and destroy the confidence of importers in that source of produce.

Outturn of produce in top condition is more important than any other requirement of packaging.

Capacity

Within reasonable limits the larger the package the lower the cost of providing and handling it. But importers know the optimum size of package they can sell. If all their customers are used to buying 15 kg pear cartons the Australian 18 kg pear carton will be found unacceptable. (Unless of course, it sells for the same price as the 15 kg carton.) If imported produce is expensive, there may be a preference for a smaller package. The 5 kg table grape carton is a winner in Europe, but cannot compete against the 10 kg carton in Southeast Asia. Research into preferred capacities is critical before package design is attempted.

* Victorian Department of Agriculture & Rural Affairs, Knoxfield Horticultural Research Institute, PO Box 174, Ferntree Gully, Victoria 3156, Australia.

Presentation

In the well-supplied world markets the retailers are the ones to impress. They are used to good presentation and obvious protection, and an unattractive package or failure to enhance the good visual quality of produce could mean that the buyers pass it by. Some North American Red Delicious apples taste like cardboard, but they are so well packed and presented the market loves them. Good wrapping of celery carries the producer's name right to the consumer, but it also protects the stalks from abrasion, browning and dehydration. In contrast some Australian vegetables, such as cauliflower, look rather second-rate. Australian asparagus exporters have learnt this lesson because they have noted the very strict requirements of the Japanese market, and they apply the same standard for other markets.

Survival

A package needs to be strong to survive through some of the market channels. At every inspection a package must be opened and resealed. It is then stacked and restacked, often with little care. Moisture content in fibre board can rise dramatically with each cooling-warming cycle, and what arrived in the ship as a good rectangular package becomes a soft football shape, with doubts in the minds of buyers about the condition of produce inside.

Suitability for Handling

Some countries have standardised produce handling on pallets, e.g. the European 1000 × 1200 mm pallet or in USA the grocery pallet 40 × 48 inches. Economics requires a high efficiency stack covering the pallet area, but good sense demands no overhang of any package. Overhanging cartons, especially when soft and moist after removal from the refrigerated ship, are most prone to collapse, and put the whole load at risk. Warehouse racks are widely used in some places and overhanging stacks make them impossible to place in the racks. Unfortunately the Australian Standard pallet 1165 × 1165 mm does not match the packages developed for the European or USA pallets. A compromise in base dimensions is necessary to satisfy good handling requirements both here and on various overseas markets. Resolution 222 of the EEC sets out a series of package base dimensions to be used in the European trade. These are simple fractions of the pallet size e.g. 300, 400, 500, 600 mm, and make no allowance for bulging or misalignment in stacking

or load unitising devices. So far these sizes have not been forced upon Australian suppliers, but it could be essential for them to be used in the future. Height of stack is also critical for European rail cars or in seafreight containers.

The International Labour Organization sets weight limits for persons of different ages to lift. For an adult female this is 16 kg. No limit is set for an adult male although the 16 kg limit could be adopted by individual unions. Many countries now observe the ILO limits and packages may need to be sized accordingly. In Southeast Asia weight limits are unknown and it is not uncommon to see Chinese labourers carrying two or three cartons at a time.

Disposability

Disposable, non-reusable pallets are a nightmare to New York importers who must have them collected and shipped out at considerable expense. Steel strapping, expanded polystyrene, tension net, polyethylene film, waxed or coated cartons, etc. all create problems for market operators and retailers. Whilst scavengers can collect and sell waste material, such as fibreboard, in most Southeast Asian cities, there is little organised recycling of packaging material. At present untreated fibreboard is the most readily recycled material in all markets.

Other Considerations

Quarantine regulations may affect the entry of some materials or require them to be specially treated. New materials are normally accepted but secondhand packaging is banned in most countries. Commodity treatments, whether applied in transit or on arrival, may require specific vents or other measures.

Product Requirements

Physical Protection

This is also foremost in market requirements, and each product needs to be considered separately. For example, peaches suffer from bruising and skin marking due to fruit movement. Bruising is more critical and a nonpressure pack is vital, but care must then also be given to immobilising the peaches, for which a better cup design in a plastic tray may be the solution.

However droplet moisture on peaches, whether from dipping or condensation, is retained with plas-

tic trays and can lead to skin browning and promote fungal infection. On the other hand, a high humidity environment is necessary to reduce moisture loss and shrivelling.

The high value per piece for large fruit or vegetables (papaw, melon, cauliflower) demands that even small bruises or rubs which affect the appearance must be avoided. Pressure relieving supports for melons, or cradles to distribute the pressure over a large surface area, are well worth the additional cost and packing effort.

Moisture Loss

Most fresh fruits and vegetables have a moisture content around 80–95%. The loss of about 2% can give a dull appearance to some fruits and limpness to leafy vegetables; 3–6% loss gives a marked loss of quality to most produce. Whilst moisture loss is primarily a function of temperature, most crops will benefit by using in-package treatments. Plastic carton liners are excellent for pears and grapes, and reduce the migration of moisture into the fibreboard, so that the carton retains initial strength during early handling stages. Waxing of the fruit, e.g. apples and oranges, has a similar effect. Waxing of the carton gives an extremely strong package, at a much higher cost and with problems in sealing and disposal. High wet strength papers should be preferred in fibreboard, and moisture problems reduced by prompt cooling, careful handling, avoidance of wetting through condensation or rain, and minimal air movement over the produce. Even lightweight sulphite paper wraps will reduce moisture loss from pears or cauliflowers. Wet strength papers are preferred for large produce such as cauliflowers or grape bunches to minimise tearing.

Package Shape

A package should be designed to suit the produce. Rectangular packages are usually preferred because they can easily be built into good stacks, but with large round produce it may be worth testing other shapes. There can be difficulties, such as with the current asparagus carton which tapers to the top. This looks attractive and follows the shape of the produce, but it fails to provide good stacking strength as one carton wall does not sit directly over the lower carton wall. Sloping sides on berry or stone fruit packages may also be a poor design feature.

Temperature Management

Vent holes are good for improved cooling rates, but also allow more rapid warming. It may be feasible to use unit covers or other devices to reduce reheating under adverse conditions, or alternatively use nonvented polystyrene boxes with close-fitting lids. These are highly successful with brussels sprouts and broccoli, where top icing is also used.

Transport Requirements

Seafreight Containers

Because most fresh produce is carried in refrigerated containers all export packages must be designed to stow efficiently into them. Packages are stowed lengthwise down the container as this gives easier stowing and good stack stability, which is especially important near the door. A regular pattern with no cross rows is also easier to stow. Most containers are about 2220 mm wide, allowing about 5–8 packages across, which sets a small number of package width dimensions if regular stow patterns are to be used. However combinations of one or two cartons stacked across the width of the containers allow much more flexibility in dimensions. Container height was standard at about 2075 mm, less an essential requirement of 50 mm for ceiling clearance. The hi-cube containers have an internal height of about 2225 mm. Given Australia's propensity for over-packing we must design packages so that, when they are commercially packed, they still have the necessary ceiling clearance.

Container length is variable, from 6.1–12.2 m externally, but, internally much more variable due to different manufacturers' refrigeration or air handling unit design. Whilst again a regular stacking pattern is preferred, it is much easier to use some cross rows to adjust the length of the stow, so that the doors can be easily closed and the air gap up the doors is not obstructed.

Unitisation

Handling unit loads rather than individual packages is essential for road freight and conventional shipping, and may be economic for container shipments. Packages must then conform to the pallet sizes appropriate to the transport mode. Although Australian efforts in unitising existing packages has been good (e.g. shrink wrap, tension net) little attention has been given to reduced strength packages

with more material going into the unit device, which offers an overall cost saving. This is only feasible if unit loads are forwarded intact to the ultimate destination, and therefore tied in to the proposed marketing procedure.

Road Transport

Many problems occur during road transport. They are vibration, which causes fruit to rotate and develop skin browning; bounce which causes bruising and displacement of produce patterns; braking forces which can move packages on pallets or in containers, and cause package distortion or even breakage; uphill shudder, which acts partly as vibration in rotating fruit and partly in moving packages rearwards; and sway which cyclically varies the weight on bottom packages causing crushing and collapse. Packages with good top to bottom compression strength and resistance to racking will avoid most problems. Particular attention must be given to single layer trays where stiffness of the package base is critical in minimising fruit bounce and rotation.

Other problems associated with road transport are rough loading and unloading, packers walking over the load to spread tarpaulins, heating of produce by radiation from the sun or the road, and heating and drying from hot winds passing through the load. These are better overcome by the use of insulated pantechinons and careful handlers, rather than by super design packages.

Moisture Changes

Every time a cold package is exposed to warm air, moisture will condense on the colder package surface. This can happen repeatedly during transport, whether it be after a few metres movement on a fork lift or after 6 weeks in a reefer container. The ideal of cooled, air-locked loading bays for transferring produce directly into the sea container from the packing shed's cool store rarely occurs in Australia. Cartons with surface coatings or high wet strength paper are necessary in those situations where absorbed moisture causes undue carton weakening.

Producer Requirements

Cost

It is easy to design an engineering masterpiece, maybe a padded steel box for fruit, but the producer

has to pay for it. Good designing must seek the best compromise between all the physical requirements and reasonable cost. For most packages material is around 75 or 80% of the package price so engineering principles which put most material in the places where it is most necessary must be followed. Top to bottom compression strength is often the prime consideration, and the use of a tray rather than a regular slotted style makes sense. Other machine-made styles are also worth consideration. Quality of material needs to consider the merits of more low-grade material or the use of less but more expensive high-grade components.

Apart from initial supply there are additional costs in empty package transport and storage. Often the storage facilities provide inadequate protection against moisture uptake or physical damage, and a higher grade packing is requested from the manufacturer. Making up the package is expensive and if inadequate, such as using poor quality or insufficient adhesive, tape or staples, or if done badly, as in racked or overdimension cartons, it can cause trouble later on.

Ease of Use

Packers do not like packages which are quite deep in relation to their length and width; they also find top flaps inconvenient, and have trouble with telescopic inners which easily spread during packing and are then difficult to square up when lidded.

Good Handling

Ratios of length, width and height for good handling and stack stability are generally accepted as L:W about 1.5:1 and $H < W$. A dumpy pear carton developed at Scoresby was excellent in container stow, material usage, palletisation and packability but would not travel easily on the rollers in the packing shed, and was rejected by industry. High packages provide good stacking strength at minimum cost but may form an unstable stack, and they risk being stacked on their side. Handling large cartons is easier if there are hand or finger holes in the ends, but damage to produce by fingernails is also important. With more mechanical handling there is less need for hand holes.

Automated Filling

Packages for vibrapacking citrus, or for automatic apple tray filling need more internal space than for

hand packing, and cannot have any projecting top flaps.

racks or buying packages with high compression strength.

Precooling and Storage

Forced air cooling is being widely adopted for its speed, economy and effectiveness. Packages must incorporate adequate venting, about 7% of the exposed face, and vents must align in the stack. Regular stack patterns of the AUF 4, 6 or 12 packages per pallet layer or the AUF 8 per layer pinwheel stack are ideal. However, produce pre-cooled before packaging must go in nonvented packages. Hydro-cooling is relatively uncommon, but wet produce or icing of produce can create problems. If produce is to be held for a period prior to export, then cool storage space must be efficiently used. Producers are faced with the capital cost of pallet

Design to Meet Requirements

Packages will continue to be modified as new ideas occur, but two factors can ensure that modifications meet actual requirements. One is the use of computers in package design, where details of packing material characteristics, produce requirements, and shipping and marketing constraints are fed in, to arrive at optimum package design for any particular set of circumstances.

The second factor is market research, finding out in better detail what the importers and retailers at the overseas destination really want. In a competitive world, if the buyers are not satisfied with Australian produce they will simply purchase elsewhere.

Simulated Commercial Export of Mangoes Using Controlled Atmosphere Container Technology

B.C. Peacock *

LABORATORY studies, conducted both in Queensland and Thailand, have demonstrated that controlled atmosphere (CA) storage of mangoes achieves a longer storage life than cool storage alone. Optimum conditions have been shown to be 5% oxygen at 13°C. The optimum carbon dioxide level has not yet been established but trials to determine this are in progress. Initial CA studies have suggested carbon dioxide in the storage atmosphere may be detrimental to product outturn quality.

Queensland studies have been financed under a grant from the Australian Centre for International Agricultural Research as part of a collaborative project (Mango Project No. 8356) with Southeast Asian institutions. This project is due to conclude with the 1986-87 research program. In an attempt to implement results into commercial practice, it was proposed to industry that they undertake three export trials during the season with assistance from officers of the Queensland Department of Primary Industries (QDPI). Initially three export trials were proposed, each of one CA container load, to Hong Kong, Singapore and Canada. This was reduced to two proposed shipments, to Hong Kong and Singapore, when it was found that Canada had not yet legislated for minimal residue levels of certain fungicides for mangoes.

The 1986-87 season in Queensland produced an abnormally low crop due to poor flowering, and local prices for this commodity remained extremely high. Local industry representatives finally decided not to go ahead with actual export trials, but to simulate an export trial by conducting a static CA

container storage trial for 3 weeks. This paper reports the results of that trial.

Materials and Methods

Fruit for the trial were obtained from three growers' properties from the coastal Ayr district of Queensland. Before harvest, the maturation of individual growers' crops was monitored by subsampling once to twice a week and determining the rate of accumulation of total solids. Harvesting was initiated when the crops were judged to be in the range of 13-15% total solids content.

It had been planned to process all fruit through a single postharvest handling plant newly installed on one of the properties. The plant is designed to phase fruit through the following postharvest handling procedures:

1. *Destemming/washing* Fruit harvested with long stems are manually destemmed and immediately placed stem end down on a set of mobile rollers. These rollers carry the fruit slowly past a set of spray nozzles which spray water vertically on to the fruit to remove sap.

2. *Hot Benlate Dipping* Fruit then enter a heated tank containing 500 ppm benlate at 52°C and are automatically held under the surface of this solution for 5 min.

3. *Cooling/Prochloraz Treatment* For this trial the line was modified so that fruit then passed through a water drench to cool the fruit and then through a spray of prochloraz (250 ppm at ambient temperature). In this trial prochloraz was applied at 1.4 l/min through each of five spray nozzles, fruit being exposed to this spray for approximately 5 sec.

* Queensland Department of Primary Industries, Sandy Trout Food Preservation Laboratory, Hamilton, Queensland 4007, Australia.

4. *Drying/Sorting* Fruit then passed under a fan using ambient air to dry the fruit, then across sorting tables where poor quality fruit were removed.

5. *Sizing/Packaging* Fruit finally passed through a computer-controlled weight grading system which automatically sorted the fruit by size which were then packaged in waxed fibreboard packages.

The three growers supplying fruit, Gosper, Nucifora, Bartlett, are specified by name to facilitate describing the methods employed and the results achieved.

Fruit from the Bartlett and Nucifora properties were harvested with stems 7–15 cm in length into picking buckets and transported to the packing machine where destemming took place. Fruit from the Gosper property were harvested without stems, washed in the property's packing shed and then transported in picking buckets to the main packing plant (on the Bartlett property).

Fruit were processed through the packing plant in the following grower order: Gosper, Nucifora, Bartlett. Fruit temperature at the start of the packing operation was approximately 25°C. On leaving the hot benlate dipping tank pulp temperature was approximately 44°C. The water drench dropped this to approximately 35°C and the fruit reached approximately 32°C on leaving the prochloraz spray.

Problems developed in the line towards the end of the packaging operation. The hot benlate dipping tank was unable to maintain temperature due to the volume of fruit being passed through it. While the final 50% of fruit from the Bartlett property were going through the line, the dip temperature averaged 47°C finally reaching 46.2°C with the last of the fruit.

During the packaging operation some fruit from the Bartlett property were packed in cartons containing plastic 'Plix' inserts, a packing aid made from polypropylene containing indentations or cups for each individual fruit. Other fruit were packed on to an absorbent pad, known as a Jiffy pad, and the rest on expanded polystyrene netting. All other growers were packed onto the latter material. The different packing materials were used to obtain some initial indication of their potential for preventing sapburn.

Following packing, fruit were transported by road to a cool room for precooling. The cool room that had to be used was running at 11°C although the

thermostat setting was at 8°C. No forced air cooling was possible because pallets were not stacked to the full height of the metal angle strips used on the pallets and hence pallets could not be sealed by a top covering sheet to make a unit suited to forced air cooling. On removal from the room the following morning pulp temperatures were 18–19°C. Fruit were loaded into a refrigerated road transport and carried to Brisbane, arriving in approximately 36 hours. Fruit were then placed in a conventional cool room and held overnight before stacking into a CA shipping container. On loading, pulp temperature was then 12°C.

The container was set to provide a storage atmosphere of 5% oxygen and 1% carbon dioxide at 13°C. A difficulty with the scrubbing system resulted in the fruit having to be twice returned to air storage, for a total of 7 days of the storage period of 18 days. Because of marketing requirements, it was finally decided to remove fruit from the container after 18 days instead of the 21 days initially planned. At the time of removal the fruit had been harvested a total of 21 days.

On removal, three cartons of each of five weight grades were removed from each grower's consignment for quality evaluation. Each of the fruit in these cartons was evaluated for external colour, anthracnose and stem end rot development. In all assessments only one assessor was used. External colour was rated on the following scale:

- 1 = surface fully green
- 2 = tinge of yellow colour
- 3 = 1/4 of the surface yellow in colour
- 4 = 1/2 of the surface yellow in colour
- 5 = 3/4 of the surface yellow in colour
- 6 = surface fully coloured.

Severity of anthracnose and stem end rot development in each fruit were both rated using the following scale:

- 1 = nil
- 2 = slight development — insufficient to affect immediate saleability
- 3 = moderate development — sufficient to influence saleability
- 4 = severe development — fruit now not marketable.

A further six cartons containing plastic plix inserts and six containing Jiffy pads were removed from the Bartlett consignment. Another six cartons containing expanded polystyrene netting were also removed from each of the other two growers. Due to an oversight, no cartons using this type of insert

were removed from the Bartlett consignment. These cartons were then used to try to establish the effects of the different inserts on sapburn development and differences in sapburn development between the three growers.

Each fruit in every carton was examined to establish to what extent sapflow continued after packaging. The fruit was examined from the stem end and an assessment made of the percentage of the visible surface area that had come in contact with sap. The rating scale used was:

- 1 = nil
- 2 = 1-10%
- 3 = 11-20%
- 4 = 21-30%
- 5 = >30%

At the same time the amount of sapburn visible was also scored using the same scale, and the intensity of the sapburn also rated as light, medium or severe. These sapburn scores and intensity ratings were then combined to produce a total sapburn score according to the following scale:

- 1 = nil
- 2 = 1-10% of surface showing light intensity burn
- 3 = 1-10% of surface showing moderate intensity burn
- 4 = 1-10% of surface showing severe intensity burn
- 5 = 11-20% of surface showing light intensity burn
- 6 = 11-20% of surface showing moderate intensity burn
- 7 = 11-20% of surface showing severe intensity burn
- 8 = 21-30% of surface showing light or moderate intensity burn
- 9 = 21-30% of surface showing severe intensity burn
- 10 = >30% of surface showing sapburn.

Results

At harvest, the total solids content of the fruit from each of the growers was as follows: Nucifora 12.9%, Bartlett 15.2% and Gosper 15.5% (Table 1). So the fruit from the first of these growers were the most immature, with the other two growers being virtually the same.

Colour and rot development on removal is also shown in Table 1. On removal from storage fruit had just commenced colour development, Nucifora's fruit being slightly more backward than the other two growers reflecting its relative immaturity (lowest TS%). Anthracnose development was virtually zero, confirming the effectiveness of prochloraz in controlling this disorder. However, very high levels of stem end rot were encountered with significant differences ($P < 0.05$) between growers. Although the degree of development was only slight (averaging 1.21-1.64) on removal, rapid subsequent development of the disease was then expected and did occur. The occurrence of this disease suggests that either the hot benlate treatment was not effective against this disease or alternatively there was a failure in the method of application.

That differences between growers did occur is of interest. Possibly the most likely explanation is that the results represent a difference in natural levels of inoculation on the three farms. The Bartlett property (the lowest level) is a relatively new farm just coming into production, and has perhaps had little opportunity yet to develop a high incidence of this disease. The Gosper farm on the other hand has the oldest trees and has had considerable opportunity for high inoculation levels to develop. Tree development on the Nucifora property is intermediate between the other two. The very high level that occurred in Gosper's fruit may also result from the fact that their fruit was destemmed in the field. There is some evidence that the presence and length

Table 1. Colour development and anthracnose and stem end rot development following CA storage for 18 days (total solids data shown for ease of reference). (Figures followed by different letters are significantly different, $P < 0.05$.)

Grower:	Nucifora	Bartlett	Gosper
Total solids (%)	12.9	15.2	15.5
No. fruit examined	245	271	236
Mean colour scores (1-6 scale)	1.98a	2.25b	2.12ab
Incidence of anthracnose (%)	0.4	0.7	0.8
Mean anthracnose score (1-4 scale)	1.008	1.016	1.012
Incidence of stem end rot (%)	29a	14b	66c
Incidence of stem end rot (%/ carton)	29.7a	15.1b	52.7c
Mean stem end rot score (1-4 scale)	1.35a	1.21b	1.64c

Table 2. Relationships between fruit size (count) and colour development and incidence of stem end rot. Data shown are the mean scores across all growers.

Fruit Count:	12	14	15	16	18	20
Mean Colour scores (1-4 scale)	2.14	2.16	2.09	2.10	2.16	2.07
Mean Stem End Rot Development (%)	58.3	29.8	31.1	23.0	27.1	30.6

of stem allowed to remain on the fruit may influence the development of this disease.

Fruit colour on removal was not correlated with fruit size (Table 2), demonstrating that size is not a good indicator of fruit maturity at harvest as more mature fruit at harvest would have had a higher level of colour development on removal. Also stem end rot development does not appear to be related to fruit size. The very high level recorded in the count 12 fruit (58.3%) may, however, be some indication that a slight maturity effect does exist.

On removal from the container the fruit immediately started to ooze sap. Why this occurred is not known. It is apparently a response to the temperature change and probably also reflects the degree of turgidity maintained in mangoes when held in the high humidity of a CA environment. This loss of sap continued for at least 24 hours (Table 3).

While such sap is not injurious to the fruit, i.e. will not cause sapburn, it does mix with water condensing on the fruit and makes the fruit sticky. It tended to collect more within the plix trays. With the Jiffy pads and polystyrene net packing material, it tended to make these materials stick to the fruit so that when the fruit was removed from the packing material pieces of it remained attached to the fruit. The amount of sap that flowed was significantly less on Nucifora's fruit. This may be a reflection of the greater immaturity of the fruit from that grower.

Sapburn development (Table 4) was significantly greater in Gosper's fruit. Gosper was the only grower to harvest without stems and it is believed this is probably the reason for them having a higher level of sapburn. The data show no apparent difference in sapburn due to the different types of inserts that were used. This cannot be taken as a

Table 3. Sapflow following storage. Data shown are the mean scores (1-5 scale) obtained on each of six cartons from each of three samples of fruit from two growers, on removal from storage and again one day later.

Grower sample	Carton No.	On removal	Removal + 1 day
Bartlett (Plix insert sample)	1	2.06	3.06
	2	1.59	2.28
	3	1.56	1.83
	4	2.00	2.29
	5	1.56	2.00
	6	1.67	1.78
Mean		1.74	2.21
Bartlett (Jiffy Pad Sample)	1	1.39	1.44
	2	1.61	1.78
	3	1.94	2.67
	4	1.64	1.86
	5	1.78	1.78
	6	1.78	2.06
Mean		1.69	-1.93
Nucifora (Polystyrene Net)	1	1.25	-
	2	1.00	-
	3	1.33	-
	4	1.13	-
	5	1.22	-
	6	1.28	-
Mean		1.20	-

Sapflow on removal < sapflow on removal + 1 day ($P < 0.05$).

Sapflow Nucifora < sapflow Bartlett ($P < 0.05$).

Table 4. Variation of sapburn in relation to grower and carton insert. Data shown are the mean scores (1–10 scale) obtained on each of six cartons within each grower sample.

Grower: Insert:	Sapburn scores (1–10 scale)			
	Bartlett Plix tray	Bartlett Jiffy Pad	Nuciflora Polystyrene Net	Gosper Polystyrene Net
Carton No.				
1	1.67	1.67	2.00	3.22
2	1.24	1.78	1.88	3.27
3	1.33	1.00	1.78	2.44
4	1.33	2.28	2.25	3.37
5	1.89	1.94	1.72	2.94
6	1.33	1.61	1.83	1.95
Mean	1.47	1.71	1.91	2.87

Sapburn Gosper > other three samples ($P < 0.05$).

confirmed result since data were not collected on the different inserts within the one grower's fruit. In examining Table 4, it should also be noted that while the sapburn scores depicted represent a low level of injury, the degree of burn could still be sufficient to detract slightly from fruit marketability.

Discussion

This trial has demonstrated that when mangoes are harvested at an appropriate degree of maturation, their storage and transport within a CA container for 3 weeks is commercially feasible. In this trial ripening was significantly delayed in spite of the fact the fruit were not under full atmosphere control for the whole period. In fact ripening was retarded to such a degree that a considerably longer storage period would have been feasible.

The problems that developed with carbon dioxide control within the container were primarily due to the efficiency of the scrubbing system employed. They in no way reflect on the viability of this type of

technology, but do indicate that improvements within the scrubbing system are required.

The level of stem end rot encountered was unexpected, and ultimately resulted in the loss of a considerable quantity of the fruit used in the trial. However, laboratory studies are still confirming the efficacy of the rot treatment that was applied, and it is believed the result was brought about by some failure or inadequacy within the system used to apply the hot benomyl treatment. Once the disease was able to occur, other factors such as spore load, destemming, inadequate cooling and failure to maintain the CA conditions for the full storage period all contributed to the degree of development that eventually occurred.

Acknowledgment

The cooperation and assistance of the Queensland mango industry in conducting this trial is gratefully acknowledged.

Disinfestation of Durable Foodstuffs in ISO Containers Using Carbon Dioxide

H.J. Banks *

CONTAINERS are widely used for transport of durable commodities such as grains, flour, pelleted animal feeds, timber and hay. These commodities may be infested with insects and other pests and usually require a disinfestation treatment, to comply with various import, export and quarantine regulations, if they are being traded internationally.

Containers and containerised cargoes provide a particular quarantine hazard (Freeman 1968) to countries at present free of particular species or critical strains of pests, as both the load and the container fabric itself are capable of carrying pests. Also containers may be taken from agricultural areas in one country directly to another without 'unstuffing' (removal of the cargo).

The range of disinfestation treatments for containers is very limited. At present fumigation is the only process available that can be used to disinfest a container and contents completely, and only methyl bromide and phosphine are in common use as fumigants. Both have properties that make their use inconvenient or unacceptable in particular situations. Methyl bromide is toxic to humans, requires trained and, in many countries, licenced applicators, and leaves residues in the commodity. Phosphine is very toxic to humans and its use is restricted by regulations and industrial requirements. Furthermore, strains of insect pests resistant to phosphine now occur in some countries (Tyler et al. 1983). Spread of this resistance would further restrict phosphine use. There is a clear need for alternatives to these two fumigants. Use of CO₂ may be one such alternative. Current knowledge on CO₂ for dis-

infestation of containers, recommendations for its use and limitations are summarised in this paper. The data and discussion refer to 20 ft (6.1 m) ISO containers filled with grain or similar durable foodstuff. Much of the basis for CO₂ use given here has been laid by collaborative research by CSIRO Divisions of Entomology and Food Research, in conjunction with other government agencies, container companies and exporters. Salient results from this research are used to illustrate particular features of the technology of CO₂ application and its development to a well-founded process, ready for commercial use.

Background

Several interrelated topics needed research during the development of CO₂ as a disinfestant for containers. These were:

- (a) the concentration-time regime required
- (b) the forces controlling gas loss from containers
- (c) quantification of gastightness of containers
- (d) methods of adding CO₂
- (e) dispersion of CO₂ through containerised cargo
- (f) level of gastightness permitting effective CO₂ use
- (g) techniques for improvement in gastightness of containers.

Concentration-Time Regime Required

CO₂-rich atmospheres are known to be lethal to most stored product pests (Bailey and Banks 1975,

* CSIRO Division of Entomology, GPO Box 1700, Canberra, ACT 2601, Australia.

Table 1. Experimental treatments of infested container loads with CO₂.

Location	Load	Initial CO ₂ concentration ^a %	Concentrations (%) at end of exposure	Exposure period (days)	Load temperature (°C)	Species ^b	Mortality	Infestation ^c	Reference
Cunningar, NSW	Wheat	68	44	4.5	22	SO	survival	bioassay	Banks, H.J., and Sharp, A.K. (unpublished data)
Rabaul, Papua New Guinea	Copra	74	45	6	25	NR OM	complete complete	natural natural	Banks, H.J., and Annis, P.C. (unpublished data)
Sydney – Hamburg ^d	Wheat	45	50	10+ ^e	26	SO RD	complete complete	bioassay natural	Banks and Sharp (1979)
Melbourne – Yokohama (6 containers) ^d	Malt	>54	>10	16+ ^e	36	SO TC	complete complete	bioassay bioassay	Banks and Annis (1980)
Lae – Sydney ^d	Coffee	c.65	36	17	c.28	SO TC	complete complete	bioassay bioassay	Sharp and van Greve (1985)
Lae – Sydney ^d (2 containers)	Coffee	c.90	5	19	c.28	TC SZ	complete survival	bioassay bioassay	Sharp and van Greve (1985)
Rabaul – Melbourne ^d	Cocoa	82	36	10+ ^e	28	TC SO	complete complete	bioassay bioassay	Sharp and Greve (1981)
Rabaul – Melbourne ^d	Cocoa	79	57	10+ ^e	28	TC SO	complete survival (<1:3000)	bioassay bioassay	Sharp and Greve (1981)
Lae – Sydney ^d	Coffee	50	20	10+ ^e	28	TC SO	survival survival	bioassay bioassay	Sharp and Greve (1981)
Lae – Sydney ^d	Coffee	58	60	10+ ^e	28	TC SO	complete complete	bioassay bioassay	Sharp and Greve (1981)

^a After sublimation of initial loose charge.

^b SO = *Sitophilus oryzae*, NR = *Necrobia rufipes*, OM = *Oryzaephilus mercator*, RD = *Rhyzopertha dominica*
TC = *Tribolium castaneum*, SZ = *Sitophilus zeamais*.

^c Bioassays were caged insects and contained all developmental stages (> 1000 insects per container).

^d In-transit trial.

^e Not vented until end of voyage, CO₂ levels may still be substantial after end of nominal exposure period.

1980; Annis, in press). These include various species of insects, mites and rodents. Snails, sometimes associated with durable commodities in containers, are also affected. Susceptibility to CO₂ varies widely with pest species and developmental stage. Some are highly susceptible. Rats and mice die with exposures of only a few hours to 25% CO₂ (Cornwell 1979). Most stages of most stored product insect pests are eliminated by exposures at >35% CO₂ for 10 days (Banks 1979). However, some developmental stages of some important species are very tolerant, requiring >60% CO₂ for >10 days for complete kill. These tolerant pests include diapausing larvae of *Trogoderma granarium* (Spratt et al. 1985) and aestivating Mediterranean white snail (*Ceruella* spp.) (Annis, P.C. and Banks, H.J., unpublished data). Response data for larvae of the wood-boring insect *Hylotrupes bajulus* and *Sirex noctilio* (Paton and Creffield, in press) suggest that some may also survive this exposure.

The current recommended target CO₂ regime for disinfestation of containers is that an initial concentration of >60% be generated and that >35% CO₂ be present after 10 days (Sharp and Banks 1980). This regime is generally supported by the results obtained in both static and in-transit trials carrying bioassays or heavy natural infestations (Table 1) and is similar to that given by Banks (1979) for treatment of static grain bulks. Furthermore, there have been no reports of infestation on outturn from commercial shipments of grain CO₂-treated to meet this regime. However, there have been insufficient well-monitored trials to give a good measure of the failure rate to be expected when the regime is just attained. Thus it must still be treated as provisional, pending further results in commercial use.

The most appropriate exposure to CO₂ remains the major area of uncertainty in the development of CO₂ disinfestation of containers. Recently obtained results from laboratory studies suggest that the regime, >60% initially and >35% after 10 days, may not be quite sufficient to eliminate some developmental stages of *Sitophilus* spp. (Annis, in press), though in the absence of *Trogoderma* larvae it is adequate for elimination of other common stored product pests. Indeed survival of a single immature *Sitophilus* was noted under an apparently adequate concentration regime in a container trial (Rabaul - Melbourne, Table 1). However, in view of the general success of the present recommendation there does not appear to be a need for a more stringent one at this time. There is an adequate

understanding of how to attain specified CO₂ regimes (see below) for the appropriate adjustments to dosage recommendations to be easily calculated if required.

Forces Controlling Gas Loss from Containers

There are several environmental forces that cause gas to be lost from within a container and to be replaced with air. These forces typically give rise to an exponential fall in concentration of a gas such as CO₂ (Fig. 1) (for relevant formulae, see Appendix

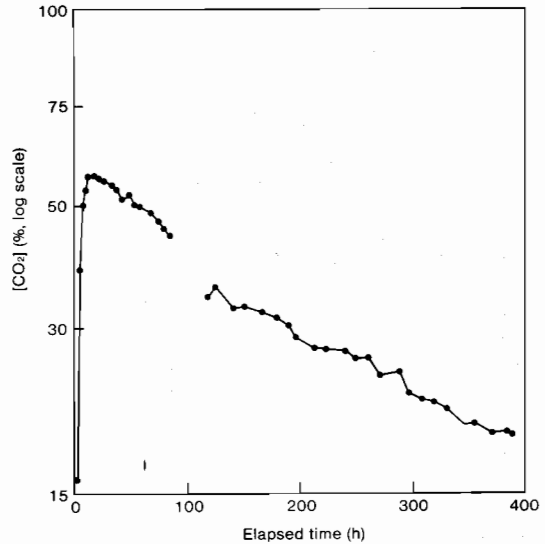

Fig. 1. Fall in CO₂ concentration with time in a well-sealed container of wheat (18 t) charged with 40 kg dry ice (Banks, H.J., and Sharp, A.K., unpublished data). Break in curve corresponds to time in transit on rail.

1). The important forces causing gas loss are wind, rate of ascent while in transit, internal (headspace) changes in temperature and variation in barometric pressure. A mathematical model has been developed to describe the quantitative effect of the various forces (Banks and Sharp 1986), predicting the individual contributions to the overall loss rate constant, k (see Appendix II). In practice, the loss of methyl bromide and carbon monoxide from container atmospheres are both well described by the model (Banks et al. 1986). Presumably loss of CO₂ can be similarly modelled.

If the concentration-time regime, >60% initially, >35% CO₂ after 10 days, is to be met, k , the loss rate constant, must be <0.054/day unless a source of gas is provided during the holding period. Predic-

Table 2. Rate constants for loss per day produced by various factors under different conditions as predicted by the model of Banks and Sharp (1986).

Factor	Magnitude	Static		In-transit	
		Leaky ^a	Well-sealed ^b	Leaky ^a	Well-sealed ^b
Internal temperature variation	10°C cycle per day in headspace	0.024	0.024	0.024	0.024
Barometric pressure variation	1000 Pa per day	0.010	0.010	0.010	0.010
Wind and transport velocity	Wind 2 m/sec Transport 8 m/sec	0.43	0.029	1.74	0.11
Ascent and descent	Ascent 6 m/sec over 3 in 1000 grade	—	—	0.19	0.19
Sum of individual effects <i>k</i>		0.46	0.063	1.96	0.33

^a 'Leaky' – pressure decay half life (250–125 Pa) 2 sec, $Q_5 = 182 \text{ m}^3/\text{day}$.

^b 'Well-sealed' – pressure decay half life (250–125 Pa) 15 sec, $Q_5 = 12 \text{ m}^3/\text{day}$.

ted individual loss rate constants for the dominant forces causing gas loss are given (Table 2) for leaky and well-sealed containers under static conditions and in transit. The parameter values used for calculation are typical for Australian conditions. Much greater values may sometimes occur though usually only briefly and having little effect on *k*, when averaged over a period of a day or more.

It can be seen from Table 2 that even in the best case given, static and well-sealed, the predicted value of *k*, the sum of the individual contributions, exceeds 0.054/day. Thus the target regime will not be met by a single charge of CO₂ gas. Furthermore, under leaky conditions, even light winds (2 m/sec) cause substantial gas loss. The problem is exacerbated by transportation since this gives an added air velocity over the containers. Ascent and descent cause particular problems. Passage over hilly terrain causes much gas loss through the pumping action of the changes in barometric pressure with altitude.

The model sets out explicitly the reasons (1) why, in practice, it is necessary to provide a source of CO₂ gas within the container to replenish the CO₂ atmosphere if the target concentration-time regime is to be met, and (2) why transport of containers on land under gas causes substantial losses. Furthermore it is apparent that containers must be well sealed to have a leak rate constant close to that required even under static conditions. Figures 1 and 2 show the increase in loss of gas caused by

transportation and an example of CO₂ loss during transit over hilly terrain and the contributions of changes in temperature and pressure to that loss. It can be seen that these changes are responsible for most of the loss observed and that the substantial drops in pressure resulting from crossing mountain ridges cause major falls (Fig. 2).

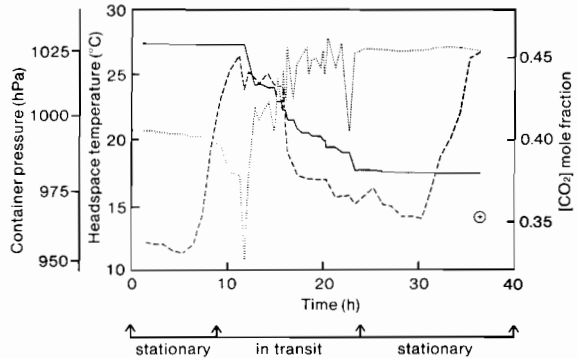

Fig. 2. Changes in barometric pressure (.....) and temperature in the headspace (-----) in a well-sealed container, load 18 t wheat, stationary and in transit on rail, with calculated fall in CO₂ concentration caused by these factors (—) and the observed CO₂ concentration (⊙) at the end of the journey (Banks, H.J., and Sharp, A.K., unpublished data).

Consideration of the effects of the forces causing gas loss highlights the need to carry out in-transit

tests when developing gas processes for containers. Good performance in static trials is a necessary but not sufficient condition for success. Furthermore tests in-transit on land are likely to be more exacting than by sea since, in the latter case, temperature variation is much reduced and there are no losses from changes in altitude.

Quantification of Gastightness

Containers vary widely in their gastightness. Some are built to a gastightness specification (e.g. reefers, bulk containers; see Sharp et al. 1986) but general purpose containers, the type most readily available, are not. Most appear to be well sealed on inspection, but when tested are frequently found not to be so.

Two objective test procedures are available for measuring gastightness: the steady state test and the pressure decay test (Banks 1984). In the former, air is introduced into the container at various known rates and the equilibrium pressure generated is observed. The variation of pressure with flow gives a measure of gastightness. In the pressure decay test gastightness is related to the time taken for an excess internal pressure to decay to a proportion, usually half, of the initial value. The steady state test is more complex and slower to carry out than the pressure decay test but is more informative. The two tests can be correlated (Appendix I).

It has been shown both theoretically (Banks and Sharp 1986) and in practice (Banks et al. 1986) that pressure test results provide a measure of the susceptibility of a container to gas loss caused by wind and transport velocity. Furthermore the effect of wind and transport velocity may be so great with leaky containers that there is little chance that the target exposure regime will be achieved. A machine, the Contestor, has been developed (Sharp 1982) for selecting containers, using the pressure decay test, on the basis of their gastightness. Inadequately sealed containers can be rejected or treated before filling or otherwise expending unnecessary effort.

Addition of CO₂ to Containers

CO₂ may be added to containers either as dry ice, as liquid forming 'snow' or as gas from cylinders. All but two of the trials carried out to date have used dry ice, even though this is a more expensive source of CO₂ than cylinders or liquid, as it is simpler to apply and a supply of dry ice is required in any case

to maintain adequate gas concentrations (see below).

The peak CO₂ concentration resulting from a given charge of CO₂ can be calculated (see Appendix I). There appears to be little difference between the different CO₂ sources in terms of efficiency of purging and the observed concentrations are distributed evenly about the theoretical curve (Fig. 3). To be sure of attaining a given concentration in the 40–70% CO₂ range, about 40% more CO₂ than theoretically is required (Fig. 3).

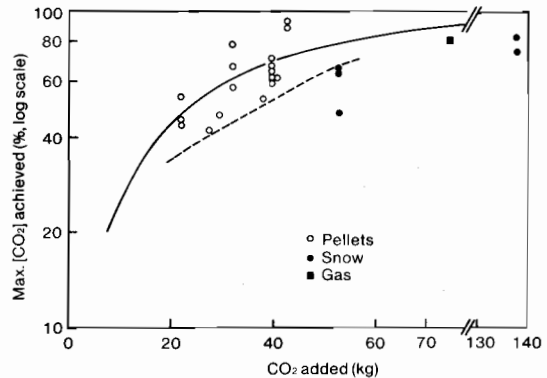

Fig. 3. Peak concentration of CO₂ achieved from various dosages. From Sharp and Banks (1980) with added data from Sharp and Greve (1981) and H.J. Banks and A.K. Sharp (unpublished data). Quantity added includes an allowance for gas liberated from slow release box, where used. Solid line, theoretical; broken line, theoretical with 40% additional charge.

The target CO₂ regime cannot be met reliably with containers of normally available gastightness using a charge of CO₂ that all volatilises rapidly, as there is no buffer stock of CO₂ to compensate for short periods of high rates of gas leakage. This is clear both from practical experience and modelling studies. Loose dry ice volatilises over a few hours (Fig. 4) and thus an alternative source of gas is required. This problem has been overcome using an insulating box containing dry ice as part of the CO₂ charge. The box restricts the rate of volatilisation, providing a continuous addition of CO₂ gas over a period determined by the heat transfer qualities of the insulation. A box made of 75 mm expanded polystyrene foam, containing >30 kg dry ice, maintains a continuous output over 10 days (a '10-day' box) (Sharp and Banks 1980). The corrugated cardboard boxes used for shipping block dry ice give a 4-day output period (Banks and Annis 1981). This shipping box contains a 22-kg block wrapped in

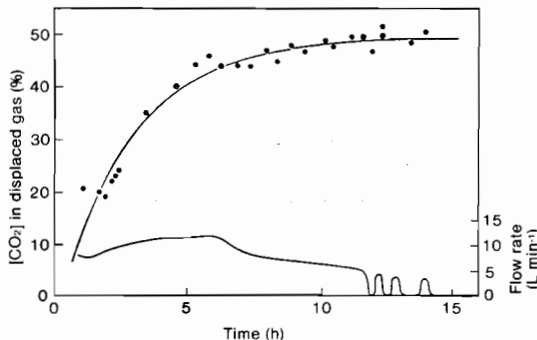

Fig. 4. Flow rate of (lower line) and CO₂ concentration in (upper line) gas displaced from a container, load 18 t wheat, during sublimation of a charge of 30 kg loose dry ice pellets (Banks, H.J., and Sharp, A.K., unpublished data).

several layers of newspaper. Polystyrene picnic baskets ('Esky') of about 25 mm thickness with 40 kg dry ice provide about 5 days of output (Sharp and van Greve 1985).

The cardboard shipping boxes gave an adequate level of insulation and output in shipping trials of malt to Japan under CO₂ (Banks and Annis 1981), but 25 mm thick polystyrene boxes did not provide sufficient insulation in a trial with cocoa and coffee from Papua New Guinea (Sharp and van Greve 1985). The two containers used in the latter trial, though still quite well sealed (200–100 Pa, 19 sec

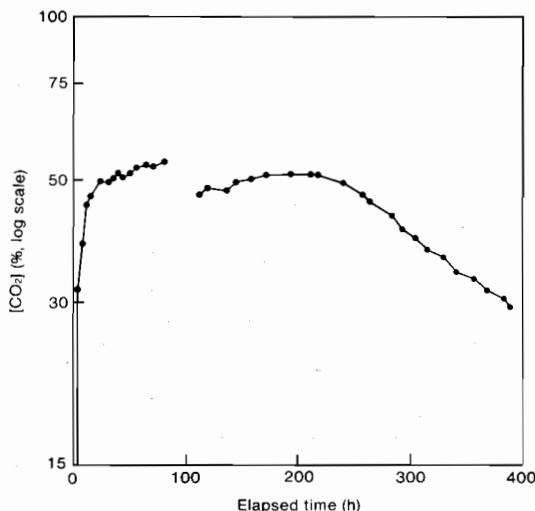

Fig. 5. Fall in CO₂ concentration with time in a well sealed container of wheat (18 t) charged with 30 kg dry ice, loose, and 30 kg dry ice in a '10-day' insulating box (Banks, H.J., and Sharp, A.K., unpublished data). Break in curve corresponds to time in transit on rail.

and 29 sec), were more leaky than the six used in the malt trial (all >48 sec). More dry ice was used in the boxes in the first trial (44 kg, second trial 30 kg). These differences may account for the difference in outcome. Boxes of 75 mm polystyrene can maintain adequate concentrations of CO₂ even against the heavy losses resulting from transportation on land (Fig. 5).

Table 3. Theoretical dosing schedules meeting the target regime (>60% CO₂ initially, >35% after 10 days) with $k = 0.18/\text{day}$ and load 18 t grain.

Loose dry ice (kg)	Dry ice in box (kg)	Time for sublimation from box (days)
33	30	10
30	60	7
35	145	5

The use of a 10-day box with 33 kg dry ice loose and 30 kg in the box increases the maximum loss rate constant, k , that still permits the target regime to be met from 0.054 to 0.18/day. If boxes giving a higher sublimation rate are used the quantity of CO₂ required to meet the target regime increases substantially (Table 3).

Dispersion of CO₂ Through a Container

CO₂ disperses rapidly when added as dry ice to the surface of a wheat bulk in a container. Concentrations throughout become almost uniform within a few hours of completion of volatilisation of the charge (Fig. 6) and remain so during the exposure

Door end			Centre			Front end		
			Liner	66				
			Head space	67				
67			Load	74				72
65				74				71
67				71				69
61	68	64	69	71	70	67	71	68

Fig. 6. CO₂ concentrations (%) in a container with a polyethylene liner, load 18 t wheat, 20 hours after closing, with 30 kg loose dry ice pellets at door end (Banks, H.J., and Sharp, A.K., unpublished data).

period. CO₂ has been observed to penetrate easily bagged wheat (Banks, H.J., and Sharp, A.K., unpublished data), copra (Banks, H.J., and Annis, P.C., unpublished data) and cardboard packing (PAL) boxes of cocoa and coffee (Sharp and Greve

1981) in containers when the charge is added to the surface of the stow.

If CO₂ is added as dry ice at floor level, stratification of the gas occurs and regimes of inadequate CO₂ are obtained in the higher parts of the stow (Sharp and Greve 1981). Presumably CO₂ added at the floor as gas or snow will behave similarly, except that the velocity of addition may cause some mixing.

Acceptable Level of Gastightness

A gastightness corresponding to a pressure decay test time of >10 sec (200–100 Pa) appears adequate to retain CO₂ in a stationary container above 35% for more than 10 days, given a '10-day' slow release box with 30 kg CO₂ and a 30 kg initial charge (Sharp and Banks 1980). Figure 7 shows the gas

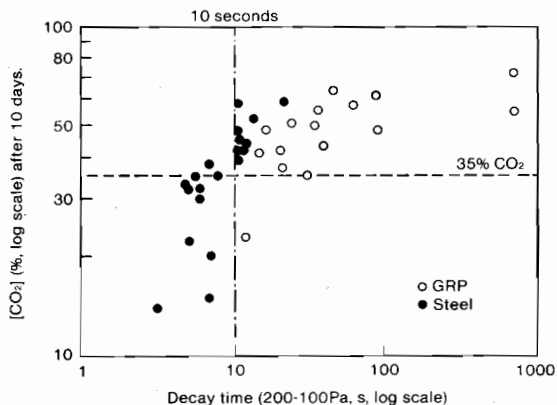

Fig. 7. CO₂ level present after 10 days as a function of pressure decay test in either static steel or glass-reinforced plastic containers, load 18 t wheat, CO₂ added, 30 kg loose with 30 kg in a '10-day' box (redrawn from Sharp and Banks 1980).

retention in general purpose containers containing 18 t bulk wheat as a function of pressure test. The level of gastightness required will depend on environmental conditions and particularly whether the container is subject to a long land journey while under gas. Increasing the initial dosage of CO₂ has little effect on whether the target is met at 10 days, though it increases the likelihood of achieving the required initial concentration. A standard of a 10 sec decay time has been found acceptable in all steel general purpose containers studied to date but there are insufficient data on performance close to this standard to give an estimate of how often it is inadequate. Only one of 16 containers made with glass reinforced plastic walls and roof failed to

retain >35% after 10 days. All had decay times of >10 sec (Fig. 7).

Improving Gastightness of Containers

Frequently general purpose containers do not meet the 10 sec pressure decay standard without some modification or repair. In particular plank-floored containers can leak extensively through the floor. None of the 22 plank-floored general purpose containers studied by Sharp et al. (1986) had sealing equivalent to this standard (Fig. 8). About 40%

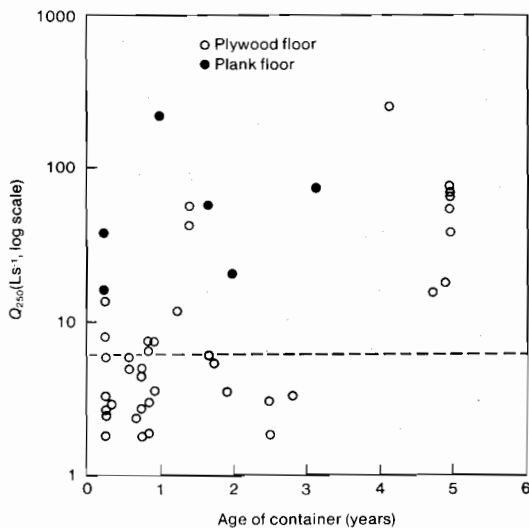

Fig. 8. Leakage at 250 Pa internal pressure as a function of container age for two types of floor construction (redrawn from Sharp et al. 1986). Dotted line represents a 10 sec decay time (250–100 Pa).

of the ply-floored ones also failed initially but only one of the 17 bulk containers did so.

Experiments have been carried out both in Australia (H.J. Banks, unpublished data) and elsewhere (Jay et al. 1983) on how to improve gastightness of poorly sealed containers. In addition to sealing defects in the door seals, walls and roof, some form of complete floor treatment is normally required with plank-floored containers. This entails considerable expense or effort and is unlikely to be commercially feasible. Successful approaches (H.J. Banks, unpublished data) include complete sheeting of the floor with polyethylene sheet, taped to the walls, and application of various coatings (Diathon, Elastuff 730 or Envelon 561/100). Ply-floored general purpose containers usually require little

effort to upgrade to a suitable level of sealing, given intact door seals and no obvious damage. It is normally sufficient to caulk each of the seams around the six sheets of ply forming the floor with silicone rubber sealant or mask them with tape. The wall-to-floor join and corners are usually the major sources of leakage.

Use of plastic film liners appears a promising approach to increasing gastightness. However, Sharp et al. (1986) note that this was not successful as tested because the liners developed leakage through tears made during loading.

Current Recommendations for CO₂ Use

Based on the research results summarised above, the following procedure should provide a CO₂ concentration meeting the regime, where >60% is achieved initially, with >35% remaining after 10 days and with gastightness of the empty container such that the pressure decay time (200–100 Pa) exceeds 10 sec.

After filling the container *either* place at least 40 kg of dry ice (pellets or crushed block) on the top surface of the stow with 30 kg or more of dry ice contained in a closed box of 75 mm medium density polystyrene foam (internal dimensions 500 × 350 × 200 mm) *or* use 40 kg dry ice pellets or crushed block with 60 kg in a closed box of 50 mm medium density polystyrene foam (similar dimensions to above).

The chances of success are maximised by keeping the containers out of sunlight and wind and adding the CO₂ after, not before, transport to the port from up-country.

Limitations to Use and Commercial Acceptance

The process described herein has gained only very limited commercial acceptance. It has been used to export wheat grown for 'health food' markets which does not permit the use of fumigants other than CO₂ or of synthetic insecticides on the grain. About 500 t of lucerne pellets were shipped from Australia in 1986 in containers under CO₂. There is some use on peanuts in containers and the process is under consideration for export hay. It is not feasible to extend the use of high levels of CO₂ to transport and disinfestation of perishables as in

most cases the commodity cannot withstand the CO₂ regime required.

Several factors prevent the process from being more widely adopted in Australia. The main problem appears to be the legal need to present commodities in a pest-free condition at point of export if they come under the Export Control Act, subser-vient legislation and Ministerial orders. Normally this precludes CO₂ as an in-transit disinfestant for use on board ship, except as a precautionary measure. However legislative provisions exist that allow exports not meeting this requirement, subject to specific agreements being established between the Australian Quarantine and Inspection Service and overseas quarantine authorities. Arranging these agreements themselves may be complex and slow. Cost is also important. The cost of the dry ice may be significant, with 70 kg costing about \$A40 when bought in lots of a few hundred kilograms. The slow release box may cost \$A10–15. However, these costs may be similar to those incurred indirectly using the cheaper fumigants, methyl bromide or phosphine. Methyl bromide requires a licenced applicator, and some countries charge for the testing of containers shipped under phosphine for safety at outturn. Finally, the need for well-sealed containers may discourage use of CO₂. It is usually possible to find suitable containers but this may involve additional effort, use of particular types of container, and cost associated with relocation of inadequate ones.

Conclusion

CO₂ use as a disinfestant is now developed to a stage where it can be used commercially. The background physics is understood quantitatively. The dosage rates for CO₂ to meet a set concentration regime suitable for control of pests are known. Limitations in CO₂ use range from regulatory requirements to its inability to control diapausing larvae of the quarantinable pest *Trogoderma granarium*. The advantages include ease of use, lack of residue on commodities and low mammalian toxicity. It is a process waiting for an application.

References

- Annis, P.C. (in press). Toward rational controlled atmosphere schedules: A review of current knowledge. Proceedings of the 4th International Working Conference on Stored-Product Protection, Tel Aviv, 1986.

Bailey, S.W., and Banks, H.J. 1975. The use of controlled atmospheres for the storage of grain. Proceedings of the 1st International Working Conference on Stored-Product Entomology, Savannah, 1974, 362-374.

1980. A review of recent studies of the effects of controlled atmospheres on stored product pests. In: Controlled Atmosphere Storage of Grains. J. Shejbal (ed.) 101-118. Elsevier: Amsterdam.

Banks, H.J. 1979. Recent advances in the use of modified atmospheres in stored product pest control. Proceedings of the 2nd International Working Conference on Stored-Product Entomology, Ibadan, 1978, 198-217.

1984. Modified atmospheres — testing of storage structures for gastightness. Proceedings of the Australian Development Assistance Course on the Preservation of Stored Cereals. B.R. Champ and E. Highley (ed.) 2, 533-543. CSIRO Division of Entomology: Canberra.

Banks, H.J., and Annis, P.C. 1981. Treatment of bulk grain in freight containers with CO₂ while in transit as an insect control measure: a commercial trial using bulk malt. CSIRO Division of Entomology Report No. 26, 1-13.

Banks, H.J., and Sharp, A.K. 1979. Trial use of CO₂ to control insects in exported, containerised wheat. CSIRO Division of Entomology Report No. 15, 11 p.

1986. Influence of transport on gas loss from freight containers under fumigation. Part II. Descriptive model. Pesticide Science, 17, 221-229.

Banks, H.J., Sharp, A.K. and Irving, A.R. 1986. Influence of transport on gas loss from freight containers under fumigation. Part I. Experimental investigation. Pesticide Science, 17, 207-220.

Cornwell, P.B. 1979. Pest control in buildings. A guide to the meaning of terms. 44 p. Rentokil Ltd.: East Grinstead.

Freeman J.A. 1968. Problems in the carriage of infested commodities in freight containers. Proceedings of the International Container Symposium, London, 1968, 79-81.

Jay, E., Davis, R., and Zehner, J.M. 1983. In-transit fumigation of truck-ship containers with hydrogen phosphide. USDA-ARS, AAT-S-28, 13 p.

Paton R., and Creffield, J.W. (in press). The tolerance of some timber insect pests to atmospheres of carbon dioxide and carbon dioxide in air. International Pest Control.

Sharp, A.K. 1982. Determination of gastightness of containers using a pressure-decay timer. International Journal of Refrigeration, 5, 348-350.

Sharp, A.K., and Banks, H.J. 1980. Disinfestation of stored durable food-stuffs in freight containers using carbon dioxide generated from dry ice. First International Conference on Technology for Development, Canberra, 1980. Institute of Engineers, Australia, National Conference Publication No. 80/10, 310-314.

Sharp, A.K., Banks, H.J., and Irving, A.R. 1986. The effect of age on the gastightness of ISO freight containers. Journal of Food Processing and Engineering, 8, 65-80.

Sharp, A.K., and Greve, J. van S. 1981. The transport of cocoa and coffee in freight containers — an experimental shipment from PNG to Australia, July/Aug. 1980 to investigate i) the use of ventilated containers to prevent

condensation and ii) in-container disinfestation with carbon dioxide generated from dry ice. CSIRO Division of Food Research Report No. 148, 17 p.

1985. Trial shipment of coffee and cocoa from Papua New Guinea to evaluate (A) in container CO₂ disinfestation and (B) techniques to prevent condensation damage. COCOF 79. CSIRO Division of Food Research Technical Paper No. 47, 39 p.

Spratt, E., Dignan, G., and Banks, H.J. 1985. The effects of high concentrations of carbon dioxide in air on *Trogoderma granarium* Everts. Journal of Stored Product Research, 21, 41-46.

Tyler, P.S., Taylor, R.W., and Rees D.P. 1983. Insect resistance to phosphine fumigation in food warehouses in Bangladesh. International Pest Control, 25, 10-13, 21.

Appendix I — Formulae

1. Rate of loss of gas from a container (Banks and Sharp 1986)

The concentration of gas, c , in a container after time, t , is given by:

$$c = c_0 e^{kt} \quad (1)$$

where c_0 is the initial concentration, k is the loss rate constant and no gas is being generated internally.

2. Correlation of pressure tests (Sharp 1982)

In the steady state test the pressure generated within the container, Δp , is related to the input flow, Q , by the formula

$$Q = b \Delta p^n \quad (2)$$

where b and n are empirical constants.

In the decay test, the decay of pressure from the initial level Δp_1 to final Δp_2 over time t is given by

$$\Delta p_1^{1-n} - \Delta p_2^{1-n} = (1-n) b K t \quad n \neq 1 \quad (3)$$

or

$$1n \Delta p_1 - 1n \Delta p_2 = b K t \quad n = 1 \quad (4)$$

where

$$K = \frac{\rho R T}{28 (V - m_{bulk}/\rho_{bulk})} \quad (5)$$

and b and n are as in equation 2.

3. Maximum CO₂ concentration expected (adapted from Banks 1979)

The maximum concentration of CO₂, c_{max} , expected from a charge of CO₂, ${}^m\text{CO}_2$, is given by

$${}^m\text{CO}_2/\rho\text{CO}_2 = (V - m_{bulk}) 1n (1 - c_{max}/100) \quad (6)$$

4. Expected concentration rise and decay (adapted from Sharp and Banks 1980)

The CO₂ concentration, c , at time t is given by

$$c = \frac{4400 [r - (r - a n_0)] e^{-at}}{(V - m_{bulk}/\rho_{bulk})} \quad (7)$$

where

$$a = r/N + k \quad (8)$$

and r is the rate of sublimation of CO₂ in kg-mol/sec.

Appendix II – Notation

b, n	empirical constants
c	CO ₂ concentration
k	gas loss rate constant
m	mass
n	moles of CO ₂ present
p	difference in gas pressure between container and external
r	rate of sublimation (kg-mol/sec)
t	elapsed time
K	a constant as defined in equation(s)
N	total moles of gas present
Q	gas input rate
R	universal gas constant
T	absolute temperature
V	container volume
ρ	density (true not bulk density)

Subscripts

0	initial
1	first reading
2	second reading
5	at SPa
bulk	relating to load
Max	maximum
CO ₂	relating to CO ₂

In-Container Cold-Disinfestation of Fruits and Vegetables

Alister K. Sharp*

UNTIL now, fruit exported to parts of the world requiring security against fruit fly was fumigated with EDB (ethylene dibromide) before leaving Australia. Ethylene dibromide fumigation is rapid and cheap, and can be applied in the container after loading for export. Now, however, EDB is suspected of being carcinogenic, and consequently its use with foodstuffs has been banned by the United States Food and Drug Administration, and most countries are phasing out its use. No other safe chemical disinfestation treatments are available to replace EDB fumigation, leaving only the physical treatments of irradiation and cold-disinfestation for disinfestation of Australian horticultural exports.

Low-dosage irradiation was approved recently by the FAO/WHO Codex Alimentarius Commission for uses that include fruit fly treatment, and it is also a suitable quarantine treatment for other pests. Irradiation is a rapid process, but the equipment required is expensive, and therefore difficult to justify for a seasonal demand. There will always be additional transport and handling costs associated with irradiation, and there will probably be consumer resistance to its use, especially for produce destined for Japan, which is one of the most promising new markets for Australian citrus fruits.

The alternative technique, cold-disinfestation, is a simple physical process which, at little additional expense, can be applied to produce which is to be stored or transported under refrigeration. Cold-disinfestation consists of prolonged exposure to temperatures near 0°C, the duration depending on temperature and on the species of fruit fly for which

the treatment is intended. Eggs and adult flies are killed by exposure to low temperatures, and larvae are sufficiently damaged to prevent them from developing into adults. Most countries which specify quarantine treatment of imports against fruit fly (Higgs 1983) follow the US requirements (Anon 1985) which are summarised in Table 1. Recent

Table 1. Time-temperature regimes specified for cold-disinfestation of fruit imported into the United States.

Maximum temperature during treatment period (°C)	Period of treatment required (days)	
	Mediterranean fruit fly	Queensland fruit fly
0.0	10	13
0.6	11	14
1.1	12	18
1.7	14	20
2.2	16	22
above 2.2	not permitted	not permitted

unpublished studies of Queensland fruit fly by C.J. Rigney at the Gosford Horticultural Postharvest Laboratory suggest that these times can be shortened; for example, effective treatment against Queensland fruit fly was achieved by 16 days below 1.5°C.

At these low temperatures, the fruit must be protected against freezing. The freezing point of oranges depends on many factors, including the variety and sugar content, and can be as high as -1°C. Cold-disinfestation, then, involves holding produce for periods of 2-3 weeks, with temperatures remaining between -1 and +2°C throughout the stow during the whole treatment period.

* CSIRO Division of Food Research, PO Box 52, North Ryde, NSW 2113, Australia.

The temperature regime needed for cold-disinfestation is most easily achieved in a cool-store, using, if necessary, additional fans to increase the rate of air circulation (e.g. as described by Watkins 1985 for forced-air cooling). But cool-store treatment involves additional handling, expense and delay. An alternative is to incorporate the cold-treatment into the transport system. If shipped in a conventional refrigerated ship, the treatment could be applied during the voyage, but most of our horticultural exports are carried in containers. An in-container treatment could be applied either before or during the voyage. Containers are smaller than cool-stores or the hold of a conventional ship, and therefore have the inherent disadvantage of having relatively large rates of heat leakage through the walls. This makes it difficult to keep temperatures uniform throughout the load, and throughout the treatment period.

A problem with any form of cold-treatment is that to satisfy quarantine authorities, fruit temperatures must be monitored throughout the treatment period; if even a single reading is above the specified maximum, the treatment period must be recommenced from when the temperature is reestablished. With pretrip treatments, this might result in the container missing the ship, and with in-transit treatments, it could result in delays and added costs to repeat the treatment after arrival. The cold-disinfestation procedure, therefore, should be carefully designed to ensure success.

There are two basic types of refrigerated container, porthole containers and integral containers, which differ in the source of refrigeration, and in the environment in which they are carried on board the ship:

Porthole containers are simply insulated, are supplied with temperature-controlled air, and are carried by 'cellular' container ships. Most produce exported from Australia to Europe and the USA is carried in porthole containers. On board ship they are stowed below deck in cooled holds, and are cooled with air from a central refrigeration system. Precise control of temperatures is possible, and, because this system is centralised, container temperatures can be supervised continually by the ship's engineers. On shore, porthole containers receive chilled air from individual 'clip-on' refrigeration units, or from 'tower-units,' and behave similarly to integral containers.

Integral containers each incorporate an individual electrically powered refrigeration unit. Pro-

duce exported to Southeast Asia and to Japan is carried in integral containers on roll-on-roll-off (ro-ro) ships. The containers may be stowed either above or below deck, but in both these locations air temperatures can exceed 35°C in the tropics. The sources and movements of heat in an integral container are shown in Fig. 1. Such high temperatures

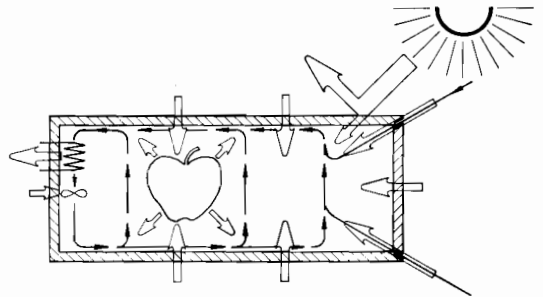

Fig. 1. Heat load on a bottom-delivery integral container, includes the heat of respiration, heat leakage through the walls and doors, radiant heat, and the heat equivalent of the fan power.

increase the rate of heat leakage through the container walls tenfold compared to a porthole container in a conditioned hold, as shown in Table 2, and the high temperatures can also affect the calibration of the refrigeration unit's temperature control system. Moreover, the operation of the

Table 2. Calculated heat loads while in the tropics, in porthole containers carried in a conditioned hold, and in integral containers at 35°C. (Stow temperature 0°C, mass of stow 15 t, heat of respiration 14 W/t, insulation value of container 27 W/°K.)

	Container	
	Porthole	Integral
Ambient temperature (°C)	2-5	35
Heat of respiration (W)	210	210
Heat leakage (W)	95	945
Heat load entering through the walls (%)	31	92

refrigeration unit is checked only once or twice each day by the ship's personnel, and not at all in rough weather. Early models of integral container, many of which are still in use, were intended primarily for frozen foods. They have low rates of air circulation (nominally 60 volumes/hour, and often as low as 40) and simple on-off control of the temperature of the return air stream. Most integral containers now being purchased by the shipping lines serving Australia have air circulation rates of 90 volumes/

hour, and for chilled produce the compressor operates continuously, controlling the temperature of the delivery air stream.

Since 1970 apples and pears consigned to the USA in cellular container ships have been treated successfully in transit by cold-disinfestation in port-hole containers, but only because special care has been given to temperature control (Husband 1976). The fruit is precooled to below 2°C before loading into the container, the container temperature is stabilised before being loaded on to the ship, and the voyage is sufficiently long to allow restabilisation of temperatures before the start of the treatment period. The containers are fitted with precision resistance temperature sensors, the hold is cooled to 0°C, and air is delivered to the containers at a temperature between -2.0 and -1.5°C, with the intention of maintaining fruit temperatures below +0.6°C for 14 days. As yet, however, nowhere in the world is in-transit cold-disinfestation practiced routinely in integral containers.

To treat produce in integral containers, the same degree of care must be applied to cooling and monitoring, and the containers must have higher rates of air circulation to compensate for the higher ambient temperatures they experience on board the ship.

A further problem in the cold-disinfestation of subtropical fruits such as oranges is that low temperatures may cause chilling injury. Chilling injury can take many forms; the term includes any disorder which would not develop if the fruit were held at a higher temperature. The most common chilling injury of oranges is the development of small discoloured sunken spots on the skin, although these often are not apparent until some time after removal from storage. Oranges grown in South Australia are more susceptible to chilling injury than those from New South Wales or Queensland; the incidence of injury depends on the variety and the time of harvest, and varies from year to year. The biochemical mechanisms of chilling injury are still unknown, but it is likely that techniques will be developed to prevent it, or at least to select export fruit which will not be affected. For example, it has been shown that chilling injury to Florida grapefruit can be prevented by prestorage conditioning at intermediate temperatures (Hatton and Cubbedge 1983).

A recent investigation at the CSIRO Food Research Laboratory (Sharp et al. 1987) was planned to assess whether cold-disinfestation of oranges is possible in the current series of integral refrigerated containers, whether the fruit can be

loaded without precooling, whether cold-disinfestation could be performed in-transit, and whether the fruit would suffer chilling injury. The requirement in this trial was to maintain the temperatures of all fruit within the range 0.0–2.0°C. In this study the temperature was monitored at a greater number of locations in the stow than in any previously published study, and sensors were placed to detect the highest and lowest temperatures. The results of other less rigorous studies, therefore, are not directly comparable.

Experimental Procedure

Two similar integral refrigerated containers, 6 m (20 ft) long and 2.6 m (8 ft 6 in) high, were selected, and were loaded with cartons of oranges, including some infested with Queensland fruit fly. One container was left in the open, at temperatures which varied around 15°C, to simulate preshipment treatment in Sydney, and the other was held in the test-room of the CSIRO Container Test Facility, at a constant temperature of 35°C, to simulate in-transit treatment while travelling through the tropics.

Containers

The containers were fitted with Email ESH 6B refrigeration units which delivered chilled air at ceiling level ('top delivery') at a nominal air circulation rate of 100 volumes/hour. These containers were fitted with wall and door battens, ensuring the flow of air over the walls and doors. The air circulation rate was checked before and after the trial using apparatus that collects the entire air stream (Irving and Shepherd 1982).

The containers' refrigeration units each had two temperature controllers, with independently adjusted setpoints; a conventional 'Partlow' electromechanical recorder-controller, and an RMC electronic controller. The Partlow controller recorded the temperature of the return air and controlled the return air temperature by switching the refrigeration compressor on and off as required. The RMC controller, which was activated only with setpoints above -4°C, allowed the compressor to run continuously, and regulated the temperature of the delivery air stream, using pulsed hot gas bypass.

Fruit

Early-season Valencia oranges, from six growers in the Mundubbera district of Queensland (150 km

inland, 300 km north of Brisbane) were harvested immediately before the trial, and were packed into vented C25 citrus cartons. These are fibreboard, two-piece cartons, comprising a lid with sides which fits over a base with sides, and have overall dimension of 450 (l) × 280 (w) × 260 mm (h). The cartons used for this trial were vented in all surfaces, giving total openings of 1.3% in the sides, 2.1% in the ends, and 5.5% in the base and lid. The fruit was not precooled, and was road-freighted to Sydney without refrigeration. A total of 644 cartons were stowed in each container, without dunnage (vertical wooden battens sometimes placed between tiers of cartons to ensure there are spaces for air to flow). The stow consisted of seven layers, with 11 full tiers and a turned tier located two tiers from the doors. (This stow, proposed by Japanese importers, left a headspace of 400 mm, sufficient to accommodate an additional layer to make a full stow of 736 cartons, still leaving a headspace of 140 mm.) The gaps between cartons of the turned tier were sealed at floor level.

Insects

A total of 1000 oranges infested with Queensland fruit fly (*Dacus tryoni*) were prepared at the Gosford Horticultural Postharvest Laboratory. Of these, 200 fruit were retained in the laboratory as controls, and the remainder were distributed amongst 10 cartons, five of which were stowed at random in each container. After the trial these fruit were returned to the Gosford laboratory, and the fruit were incubated for 3 weeks at 26°C over sand. The standard of survival was taken to be the formation of a normal puparium, judged as one which produced a live adult fly.

Temperature Measurement

Temperatures were monitored at 50 locations in each container, at 2-hour intervals, using thermocouples inserted into fruit placed at the centres of cartons located as shown in Fig. 2.

Operation

Immediately after the containers were loaded the refrigeration units were started with setpoints of 0.5°C. After 2 days it was apparent that the temperature spread in both containers was greater than 2°C. Accordingly the setpoints of the controllers were reduced in steps to give minimum fruit temperatures of 0.0°C.

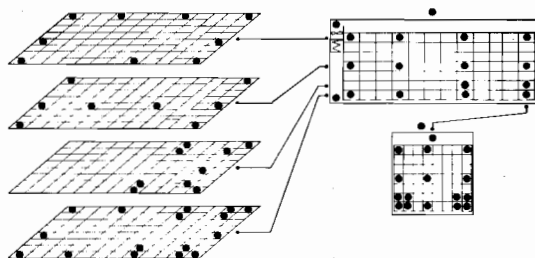

Fig. 2. Locations of the temperature sensors. A thermocouple was inserted into the centre of an orange which was placed at the centre of each marked carton. The sensors were monitored automatically every 2 hours throughout the trial.

The stowage pattern, too, was modified progressively to reduce the range of temperatures throughout the container. In their final stowage configurations, in the Outdoor container all vents permitting vertical air flow through the cartons were sealed. In addition to this, in the Testroom container gaps between cartons in the turned tier were sealed at the top surface of the stow as well as at floor level, and the door ends of the centre half of the floor channels were sealed. Details of the stow modifications are given below Table 3.

Results and Discussion

Performance of Containers

The containers operated as expected, except that the air circulation rates were less than that specified, and that they were unable to cool warm produce rapidly.

Although these containers have specified air circulation rates of 0.75 m³/sec, when measured before being loaded, air circulated through the Outdoor container at only 0.68 m³/sec, and through the Testroom container at only 0.53 m³/sec. A poorly fitting air duct inspection cover in the Testroom container allowed part of the airstream to bypass the loadspace; replacement of the adhesive-backed foam gasket increased the lower circulation rate to 0.67 m³/sec, but when rechecked at the conclusion of the trial the circulation rate had reverted to 0.53 m³/sec. It was assumed that both containers operated at 0.67 m³/sec (90% of specification) throughout the trial.

When cooling warm fruit, with the controllers adjusted to deliver air at +0.5°C, cooling was much slower than expected. This was traced to a faulty

Table 3. Summary of temperatures achieved in both containers, with various stows, after reaching steady-state conditions.

Container	Mean ambient temp (°C)	Stow	Set-point (°C)	Lowest temp (°C)	Highest temp (°C)	Temperature spread (°C)
Outdoor	12	A	0.5	0.7	2.9*	2.2
"	15	B	-0.3	0.0	1.6*	1.6
Testroom	34	A	0.5	0.7	3.2	2.5
"	34	B	0.5	0.8	2.7	1.9
"	35	C	-0.2	0.0	1.7	1.7
"	35	D	-0.2	0.1	1.9	1.8
"	35	E	-0.2	0.0	1.6	1.6

* cycling $\pm 0.4\text{ }^{\circ}\text{C}$ with daily change in ambient temperature.

Note: Stow A: fully vented cartons, gaps between cartons of the turned tier sealed at floor level.

Stow B: vents sealed in the upper surfaces of the top layer of cartons.

Stow C: all vent openings sealed in tops and bottoms of all cartons.

Stow D: spaces between cartons of the turned tier sealed at the top of the stow.

Stow E: the central half of the floor channels sealed at the door end of the container.

defrost system, which did not clear ice from the evaporator coils. When operating at constant temperature, and later when warming the stow, the Partlow on-off controller sometimes took over from the RMC controller, resulting in fluctuating temperatures. McLauchlan (1984) reported the same problem in an earlier study of similar containers. It would seem desirable for the on-off Partlow controller to be disabled when the RMC controller is active.

When operating at steady-state, the RMC controllers maintained constant delivery air temperatures, but showed calibration errors of $0.2\text{ }^{\circ}\text{C}$ (Outdoor container) and $0.4\text{ }^{\circ}\text{C}$ (Testroom container). Although very stable control of temperature is essential for cold-disinfestation, the accuracy of calibration of the controller is less important, because the temperature of the coolest fruit always must be monitored independently, to ensure it does not fall below the freezing point, and this temperature can be used to adjust the controller's setpoint. The temperature of the warmest fruit must also be known to ensure the specified quarantine treatment is applied.

Product Temperature

Two temperature parameters were of interest: the rate of cooling, and the steady-state temperature spread. Both depend on the temperature, the air circulation rate, and the uniformity of distribution of the circulating air. The air distribution depends on both the design of the container and its refrigeration unit, and also on the design of the carton, and on the way it is stowed. During the original cooling, the

stow consisted of vented cartons. The results given below refer to a nonvented stow, and were obtained at the conclusion of the disinfestation period, when the stow was warmed to 10°C , and then recooled to 0°C .

Temperature Spread

The temperature spread is the difference in temperature between the warmest and the coolest fruit in the container. If the controllers are adjusted to keep the coolest fruit just above the freezing point, the temperature spread determines the temperature of the warmest fruit. The effects of the various modifications made to the stow are shown in Table 3, which lists lowest temperatures measured at the coolest locations in each container with each stow, and the highest temperature measured at the warmest location in each.

These results show that the coolest fruit was always $0.2\text{--}0.3\text{ }^{\circ}\text{C}$ warmer than the delivery air temperature, and, for a given stowage pattern, the temperature spread was greater in the Testroom container than in the Outdoor container, showing the effect of the higher ambient temperature. With each of the stows most fruit were within a narrow temperature range, and in no case is it estimated that more than four cartons (i.e. 0.6% of the stow) were in the highest 0.5°C temperature range. While these few cartons could be ignored if only fruit quality were concerned, they are critically important in a quarantine treatment. Of the various modifications made, the only one to make a marked difference to the temperature spread was to seal the vent openings permitting vertical air flow through the cartons.

Since each pattern of stowage was symmetrical about the axis of the container, and the air delivery pattern is also nominally symmetrical, the fruit temperatures were also expected to be symmetrical. This was not the case, however, and temperatures of corresponding cartons on opposite sides of the container differed by as much as 0.5 °C. Furthermore, this could not be explained by an asymmetrical air supply system, because after the containers were restowed the higher temperature was sometimes found on the other side of the container.

Rate of Cooling

The response of a stow to a reduction in air temperature is commonly measured as the half-cooling time. The half-cooling times at various locations in the Testroom container, with the final stowage configuration, are given in Table 4 (these values of half-cooling time have been corrected for the faulty operation of the refrigeration unit).

Table 4. Measured half-cooling times of cartons at various locations in the container (Testroom container, final stow configuration).

Description	Location	$t_{1/2}$ * cooling
Fastest-cooling	Centre of lower edge near doors	27
-	Centre stow, 1/3 length from doors	51
Slowest-cooling	Centre stow, refrig. unit end	73
Eventual coolest	Near air delivery outlet	32
Eventual warmest	Lower outside corner near doors	28

* $t_{1/2}$ (hours) is the time taken for the temperature to change half-way from its initial to its final value.

Different parts of the stow cooled at greatly differing rates; the part which cooled fastest initially did not eventually become the coolest, because the initial rate of response at any part of the stow depends mainly on the local rate of air supply, whereas the eventual temperature depends also on the local rate of heat supply. Similarly, the part which cooled most slowly did not become the warmest.

Estimates of the time required to cool the last carton of a stow of nonvented cartons below 2.0°C, based on the measured cooling responses, but corrected for the poor performance of the temperature controller, are given in Table 5 for initial temperatures of 20°C (i.e. fruit not precooled), 10°C (i.e. fruit from a cool store), and 4°C (i.e. fruit pre-

Table 5. Estimated time required before the last carton has cooled to below 2.0°C from various initial conditions. (Final stow configuration, assuming delivery air temperature falls to 0.0°C immediately.)

Initial condition	Initial temperature (°C)	Cooling time (days)
Uncooled	20	6.7
Normal storage	10	6.5
Precooled	4	3.3

cooled to 2°C, and loaded in the open). Precooling would save 3.4 days, which might be important if the fruit was to be treated on land before export, but it is probably not important for in-transit treatment, because the container would usually be kept in the terminal, on power, for this period before export. The original fully vented cartons would allow the fruit to cool more rapidly, but these would not produce the required temperature uniformity.

Effectiveness Against Fruit Fly

From the 200 control fruit, 7234 normal pupae were recovered. Assuming the same ratio of insects to each of the infested fruit placed in the containers, a total of 28 936 insects in each container was exposed to the cold treatment. No survivors were detected, giving a mortality rate of not less than 99.997%.

Chilling Injury

Inspection of the fruit as it was being unloaded from the containers revealed some small brown pits characteristic of chilling injury. From each container 12 cartons of fruit were selected at random and stored at approximately 20°C. The remainder of the fruit was sold at the prevailing market price. After 3 weeks storage, to simulate marketing, the fruit were examined individually. A total of 45% of the fruit showed some injury, generally of a low level, but sufficient to affect its value on the Japanese market, but because there were no controls, it is not possible to identify this positively as chilling injury.

Conclusions and Recommendations

1. These containers, fitted with Email ESH 6B refrigeration units, are capable of keeping an entire stow of fruit within a temperature range of 2°C,

even at an ambient temperature of 35°C, and in this experiment maintained temperatures between 0 and 2°C for 17 days, which was sufficient to kill all Queensland fruit flies present.

2. The air circulation rate in both containers was below the specified value due to poorly fitting inspection covers. These covers should be redesigned.

3. If the minimum temperature of the fruit were set to -0.5°C, the maximum would be no more than 1.5°C, and cold-disinfestation treatment for Queensland fruit fly would be completed in 18 days under current USDA requirements. The treatment period could be shortened by lowering the temperature of the coolest fruit, but this would create a risk of freezing, should the temperature control system of the container's refrigeration unit be out of calibration.

4. Four temperature sensors are required per container, to provide evidence of adequate treatment for quarantine authorities: one to measure the minimum fruit temperature (to ensure no fruit is frozen), one to measure the temperature of the last fruit to cool to treatment temperature, and two to detect the maximum fruit temperature, because there are often differences between the temperatures of corresponding positions on opposite sides of the stow.

5. Stow temperatures depend to some extent on the vagaries of the particular stow. To cool fruit to the minimum temperature possible without freezing, it is advisable to measure the temperature of the coolest fruit directly, and to adjust the container's controller accordingly. This will compensate for calibration errors in the container's temperature control system. The temperature sensors mentioned above could be used for this purpose.

6. Cartons with vents in the upper and lower surfaces, permitting vertical air flow, are not suitable for cold-disinfestation because air short-circuits through the cartons, allowing the door-end of the stow to remain excessively warm. For the same

reason no dunnage should be used when stowing a container for cold-disinfestation. Preventing the air stream from contacting the fruit directly will also help preserve quality during the voyage by reducing moisture loss. However, to allow rapid pre-cooling before the fruit is loaded into the container, the cartons may still be vented in their sides and ends.

7. An undunnaged, nonvented stow cools relatively slowly, and precooling before loading into the container may be necessary to reach treatment temperature in an acceptable time, especially if disinfestation is to be carried out before shipment.

References

- Anon. 1985. Plant protection and quarantine treatment manual. US Department of Agriculture Animal and Plant Health Inspection Service.
- Hatton, T.T., and Cubbedge, R.H. 1983. Preferred temperature for prestorage conditioning of 'Marsh' grapefruit to prevent chilling injury at low temperatures. *HortScience*, 18, 721-722.
- Higgs, G.M. 1983. Summary of overseas countries requirements for entry of fresh fruit and vegetables. Canberra. Department of Primary Industry.
- Husband, R.M. 1976. Killing fruit fly with cold air in containers. Annex. Bulletin of the International Institute of Refrigeration, 1976-1, 517-525.
- Irving, A.R., and Shepherd, I.C. 1982. Measurement of air circulation rate in integral refrigerated shipping containers. *International Journal of Refrigeration*, 5, 231-234.
- McLauchlan, R. 1984. Valencia orange export to Japan: ANL's ESH6B series containers. Sandy Trout Food Preservation Research Laboratory. Project Report No. F8225.04.
- Sharp, A.K., Irving, A.R., and Rigney, C.J. 1987. In-container cold disinfestation of oranges as a quarantine treatment against fruit fly: a static trial. CSIRO Division of Food Research, Technical Paper 51.
- Watkins, J.B. 1985. Forced-air cooling. Queensland Department of Primary Industries. Information Series Q185022.

Summaries of Information and Review Papers

Full texts of individual papers are available on request
from ACIAR, GPO Box 1571, Canberra, ACT 2601,
Australia.

Constraints on the Export of Fruit and Vegetables from Australia and Market Requirements Overseas

J.D. Baker *

AUSTRALIA is fortunate that the world's major population centres are in the northern hemisphere, giving us an excellent opportunity for out-of-season marketing. We also have a range of climates far greater than any of our southern hemisphere competitors (South Africa, Chile and New Zealand), enabling us to take advantage of a wider range of market niches.

Market indications for produce include:

Product	Market				
	Southeast Asia	Japan	Europe	North America	New Zealand
Oranges	x	x	x	x	x
Lemons	x	x	x		x
Easy-peels			x		
Apples	x		x	x	
Pears	x		x		x
Grapes	x	x	x	x	
Kiwifruit		x	x	x	
Cherries	x	x	x	x	
Sugar Plums	x				
Stone Fruit	x		x	x	
Avocados			x	x	
Lychees	x		x		
Nashi fruit	x		x		
Mangoes	x		x		
Asparagus	x	x	x	x	
Onions		x	x		
Melons		x			
Broccoli	x				
Chinese Cabbage	x				
Lettuce	x				
Ginger	x		x		

Southeast Asia

Fruit and vegetables worth approximately \$1000 million were imported into Hong Kong, Malaysia and Singapore in 1982-83, with Australia's share at \$80 million or 8%.

The breakdown between markets was:

	Total Imports	Imports from	Market Share
	A\$m	Australia A\$m	%
Hong Kong	575	20	3
Malaysia	150	29	19
Singapore	250	31	12

Hong Kong is the largest and fastest-growing market, yet it is the market where Australia has done very little. Based on the total import volume into Hong Kong and Australia's production base, it is realistic to believe that the following export volumes into Hong Kong could be achieved:

Apples	8000 t
Carrots	1000
Cabbage	4000
Grapes	2000
Lemons	1000
Melons	3000
Onions	3000
Oranges	35000
Pears	8000
Prunes	1000

* Secretary, Sydney Market Authority, P.O. Box 2, Flemington Markets, NSW 2129, Australia.

If these targets were achieved it would boost export revenue by at least A\$50 million.

Japan

Markets in Japan are already being serviced in a small way from Australia with products like onions, asparagus and oranges. Profitability in the onion business is based on being in the market every year to take advantage of shortfalls that can occur in Japanese domestic production.

The asparagus market has been well developed in recent years by producers and exporters from Victoria and New South Wales, and is a good example of how markets can be successfully developed and expanded.

The orange trade was opened to Australia 3 years ago but has been slow to develop. In 1987 it is likely to be around 1000 t. The main reasons for the slow development are the focus on processing by the industry and the lack of volume postharvest and packing facilities. Australia could realistically set a target of developing an export market of 50 000 t of oranges in the period June to November, in the northern hemisphere off-season.

Market access related to quarantine is an issue for most of Australia's other fruits and some vegetables. The Japanese have clearly indicated that the next products they are interested in obtaining from Australia include lemons, kiwifruit, cherries, grapes, melons, and apples.

Europe

Europe is a market that has been poorly serviced by Australia, and market share has been lost as other southern hemisphere countries have expanded their production. Countries like Chile would not have developed horticulturally to their present level if Australian producers and exporters had been more committed to the market over the past 10–15 years. Despite Australia's poor image in Europe there is still strong interest in obtaining produce from people who are committed to developing and servicing the trade.

There is a wide range of products that have potential in Europe, particularly pome and stone fruit, citrus, grapes and berry fruit.

North America

For development and servicing purposes, North America should be seen as at least three markets — east coast and west coast USA and Canada.

Canada represents a market bigger than Australia with a less varied range of products grown domestically. In the United States, Australia's export

volume is so small as to be almost unidentifiable. An indication of the market that is available can be gained from the fact that in 1985–86 Chile exported in excess of 21 million packages of fruit to the United States, yet this was insufficient to satisfy the off-season needs of the primary retail outlets. Main products were grapes, apples and stone fruit.

New Zealand

New Zealand represents a small but significant market for oranges, lemons, tomatoes and pears. It has the attraction of being close and easy to service. Limited opportunities for other products exist, because New Zealand does not have the range of climates for year-round production of vegetables or early season production of some fruits.

Constraints

Market Access

Major market access issues are Quarantine and Transport.

In the area of quarantine, the two markets restricted to Australian products are Japan and North America. Resolution of the quarantine issues needs to be based on discussions at both policy and technical levels.

The focus of transport in export horticulture has traditionally been on negotiating freight rates. However, the people negotiating freight rates have never had control of the product, and until this is so the exercise is pointless.

The two market access issues in transport are Service and Technology.

Two major markets currently restricted to Australian produce by the shipping service are Europe and Southeast Asia. With Europe all west-bound services terminate in the Mediterranean, and east-bound services to Northern Europe call at New Zealand. This effectively adds 10–20 days to the sailing times compared to 20 years ago. There needs to be coordination, both within and between industries, so that at key times of the year better services can be requested to northern Europe.

In the past 12 months the New South Wales Horticultural Export Development Council has concentrated its efforts on seeking a better service from the east coast to Hong Kong. This has now resulted in a one port load/one port discharge service between Sydney and Hong Kong, with the further result that

produce formerly shipped by air is now being sent by sea.

Shipping technology is another area for development. Industry knows that techniques like controlled and modified atmosphere containers are theoretically of value, but they have yet to be adopted adequately. In the area of air freight there are also materials such as one-use bubble insulation that could extend shelf life for highly perishable products like asparagus and cherries.

Product

Major constraints in this area are lack of supply, inconsistent supply and lack of organisation, and all three relate to each other.

The first two requirements of a market are consistent quality and consistent supplies, and until this is realised by the Australian export industry it will continue to be a price taker rather than a price setter on the international stage.

People

With few exceptions, there is a general lack of marketing skills, not just in horticulture but in agriculture in general. There is a major challenge in Australia to develop in people the necessary practical marketing skills that are required and recognised internationally. No educational institution in Australia is currently working in this area.

Finance

Exporting fruit, vegetables and flowers is an expensive business, as also is investment into the production of these products. Seasonal finance to cover the cost of export is generally not available, although steps are being taken to overcome this

problem. In the production area, large sums are needed to invest in farms of economic size, and with the waiting time until full production there has been little incentive for entrepreneurial investment in traditional horticultural products.

Overregulation

Regulations governing product standards for fresh fruits and vegetables have been developed largely by government, with some consultation of grower groups and the horticulture trade. In recent times emphasis has been given to the development of export regulations based on OECD standards.

Some of the results of this focus have been: (i) Development of minimum standards covering all markets (despite the fact that requirements vary from market to market); (ii) Emphasis being placed on quality control by government inspection rather than quality assurance by producers; (iii) Reliance on export regulations to define market specifications.

Materials-Handling

Australia can justly claim some recognition for its rationalisation of materials-handling on the domestic market, revolving around the Australian standard pallet and appropriate packages to suit. However, the Australian pallet is not used internationally, and industry has yet to come to grips with rationalisation of materials-handling procedures for export. The world is increasingly going towards a pallet of 1200 × 1000 mm or the shipping pallets similar to those used by New Zealand and South Africa.

Australia has to follow suit if we are to gain access to sizeable markets in the northern hemisphere.

An Exporter's Approach to Shipment of Fresh Produce from Australia

T. Pilavachi *

I AM one of the smallest exporters of fruits and vegetables operating from Flemington Markets, exporting mainly to Southeast Asia and Middle East countries. I believe that Australian produce has great prospects on world markets, but it is important for exporters to consider the following factors:

1. Successful exporters must be confident and persistent.
2. We must visit prospective clients regularly to get to know them and their requirements.
3. Reliability of supply is essential.
4. Freshness, size and visual appeal of the product are also very important.
5. Packaging must be attractive as well as safe, and a logo with a strong local motif (such as a kangaroo inside a map of Australia) is an advantage.
6. Free samples can help to capture export business (and the cost is refundable).
7. You should occasionally accompany your shipment overseas to see in what condition the goods arrive at the destination.
8. Quotations for fruits and vegetables should be telexed to prospective importers regularly (at least once a week).
9. Ask your importers if they are satisfied with your operations.

During autumn and winter months exporters may depend entirely on Queensland produce, but some of the packaging used by these growers is unsatisfactory. The produce requires repacking, which is labour-intensive and an additional expense, and this

subject requires further attention. Currently, there are over 100 different packages used in the Australian horticultural industry, and some rationalisation is required.

Exporters must deliver the appropriate product to the importer in the right quantity at the right time and in the best possible condition. It is also necessary to undertake promotional campaigns, which are vital elements in any marketing strategy.

Export Strategies

The United States is Australia's main competitor in Southeast Asia. American exporters have recognised for some time the importance of reducing distribution costs in supplying large volumes of high quality, competitively priced produce to a distant market on a regular basis. An example is the 'Sunkist' effort, which has established itself in the minds of consumers as synonymous with premium quality, and the organisation has successfully set out and maintained the quality and packaging standards by which all other citrus fruits are judged in Asia.

Sunkist in fact consists of some 12 individual packing concerns in California, but by carefully coordinating activity the organisation is able to regulate acid levels, packaging, marketing and promotion, to ensure that citrus of varying sweetness is directed and sold according to the differing consumer preferences of different countries. For example, low acid fruit is preferred in Asia, while high acid fruit is sent to Western export markets.

I have not found the Sunkist taste particularly

* Terry's Export Produce Pty Ltd, Market Plaza, Flemington, NSW 2129, Australia.

good, and when I organised tastings of Australian oranges, which I consider to be better, they were a great success. However, it will require a carefully

planned and coordinated operation, such as that of Sunkist, for Australia to make effective, long-term penetration of these markets.

Transport of Perishables by Road

T.O.D. Hughes *

THE carrier of perishables by road transport has to recognise two principal functions: (1) the transport function of moving products from one point to another in a given time; and (2) the processing function which requires the carrier to maintain the Cold Chain preservation process during the journey.

The Cold Chain is a quality preservation process, operating through from harvest to consumption and involving biochemical physical and microbiological aspects.

Different Cold Chain operating specifications are required for different perishable food products. This paper will principally consider the application of the Cold Chain to fruits and vegetables.

Transport is a significant proportion of the cost of the product's selling price. Each fruit and vegetable has its own temperature characteristics, and these vary under different conditions. It is necessary for those engaging road transport to fully brief the carrier of the relevant Cold Chain specifications, so that produce arrives in optimum condition.

In trades of limited cargo, it may be necessary to transport various products with different Cold Chain specifications. Also, some products may taint the taste and smell of other products in the load. There is considerable information available as to desirable maintenance temperatures and the compatibility of different products.

Road haulage of perishables requires understanding of heat of respiration of produce. After harvest the produce, under normal conditions, continues to 'breathe,' giving off heat and generating carbon dioxide. The heat given off is known as the heat of

respiration, and varies considerably from product to product.

When the produce has been cooled to a specified transport or storage temperature, respiration and hence heat generation is no longer significant. Reduction in respiration can also be achieved by modifying the composition of the atmosphere surrounding the produce.

If the respiration is allowed to continue, steps have to be taken to ventilate away the carbon dioxide, as a high concentration can suffocate the produce.

The first link in the Cold Chain for fruit and vegetables is precooling, whereby the product temperature is reduced from field heat to the desired temperature. Ideally, field heat should be removed rapidly and evenly, and the product should not regain sufficient temperature to cause significant respiration. The most effective precooling is carried out in properly designed terminal facilities, but en route precooling is also practiced. Good terminal precooling can present opportunities for much cheaper forms of transport under appropriate conditions.

To carry out this process responsibility fully, the carrier needs the following information:

Product Requirements

The carrier should have access to general data on all products, such as temperature, relative humidity, and controlled atmosphere ventilation requirements, critical minimum temperature (for damage), heat of respiration generated, susceptibility to physical damage and preferred stowage arrangements, and which products are incompatible in mixed loads.

* Transport Consultant, Queensbury Pty Ltd, 5 Shinfield Avenue, St. Ives, NSW 2075, Australia.

Specific Details of Each Cargo

Such information includes nature and quality of products to be carried, extent of precooling if any, nature of packaging and any stowage patterns required, use of bulk bins or pallets, and size of load. The carrier should also know the market expectation of delivered quality, since there is unnecessary expense in supplying an unsophisticated market requirement by way of sophisticated refrigerated transport.

Bulk bins can help by keeping incompatible cargoes separate, and permitting carriage of mixed loads with different temperature or other requirements. There is also less handling involved in loading and unloading.

Route Conditions

Important factors are road quality (load cushioning may be required), route limitations on vehicle size, likely ambient temperatures and weather conditions, distance and expected trip time, terminal facilities at either end and any requirement for enroute facilities.

Economic Factors

The most profitable results require well-organised loads which are full in both directions. Where this is not possible, operational modifications may need to be considered. For the refrigerated carrier, the weight and the reduced internal cargo space measurements make it difficult to carry dry cargo

competitively. Single-purpose vehicles employed in a seasonal trade where there is no alternative application for the vehicles face uneconomic cost structures. Seasonal trades require an examination of the possible short-term modification of dry cargo vehicles.

En-Route Process Equipment

Important factors to be considered are:

(a) Quality of insulation, which will determine degree of refrigeration required. Insulation may be reflective against radiation, e.g. aluminium foil (best as two separate layers 25 mm apart), or by insulating layers of foam or gas against conduction. Air leakage must be minimal.

(b) Body construction, in relation to sealability, and requirements for hygiene, loading convenience, ventilation, durability, weight and cost of maintenance.

(c) Refrigeration techniques, which may be non-mechanical (ice, dry ice, eutectic plates, etc.) or mechanical (by compressor, evaporator, condenser or fans, driven either by the prime mover or by a separate combustion engine). Each has particular features, and the carrier must judge which is best suited to the load requirements.

(d) Airflow, which is determined by body construction but can be affected by blockage of inlets and by resistance or short-circuiting caused by the pattern of stowage. The carrier must be fully aware of the load requirements and how such shortcomings can be avoided.

Shipment of Fresh Produce by Air

Roger Parkes *

SOME years ago air cargo was the poor cousin to passenger traffic within Qantas, but not today. The cargo business might still be smaller than the passenger business, but it commands equal respect within the corporate headquarters of Qantas, and it plays a significant role in Australia's export drive. About 130 times each week Qantas jets fly out from Australia to the rest of the world, to 30 ports in 24 countries. England and Europe, Asia, North America, Africa and countries in the South Pacific (including Papua New Guinea) are all on the Qantas network. Every week Qantas aircraft carry overseas about 1000 t of Australian exports, worth more than A\$20 million.

Bulk commodities such as ore, coal, grain and wool are only suited to surface transport (normally by foreign-flagged ships, at a cost to Australia's balance of payments). It is the more valuable products that warrant airfreight, which accounts for 1% of weight but 8% of total value of Australia's exports.

Surplus air cargo space is generally available, at highly competitive rates. For example, a typical airfreight rate from the US West Coast to Australia is A\$6/kg, whereas the rate available to Australian

exporters sending primary produce in the other direction is about A\$1.50/kg, one of the cheapest air cargo rates in the world.

Fresh fruit and vegetables comprise Australia's main export items by air. About 70% and on some routes as much as 90% of Qantas's total cargo flown from Australia comprises foodstuffs. Perishable cargo does present difficulties not found with manufactured products, however. It has to be kept at low temperatures, and so requires special packing. It needs cool rooms at cargo terminals, for delays on a hot tarmac could result in a condemned consignment. It is highly seasonal, and so demands an inordinate amount of capacity for just a few short weeks of the year. It is subject to health inspections and special documentation. It is subject to the vagaries of the weather and the unpredictability of production, and so predictions of capacity demand are hazardous at best.

Despite these requirements, Qantas decided a few years ago to establish a special cargo division, and demonstrated its faith in the future of perishable air cargo by massive investment in airport terminal and aircraft hold facilities, complex cargo tracking facilities, and a cargo staff of 600 people. The facilities are there — it is now up to growers to produce the goods that merit them.

* Director of Cargo, Qantas Airways Limited, GPO Box 489, Sydney, NSW 2001, Australia.

Selection of the Right Packaging: Engineering Aspects of Package Design

L.B. James *

THE aims of packaging for fresh produce are:

- (a) To protect produce from physical, physiological and pathological damage;
- (b) To assemble produce in marketable quantities and present it to the market in a form and condition that entices buyers; and
- (c) To facilitate handling through the various distribution systems involved.

One of the first steps in a package design project is to investigate the extent to which distribution systems and methods can be modified to reduce the hazards to produce, and the possible use of techniques such as forced cooling, gassing, etc.

Fundamental to the actual produce packaging is protection. Engineering principles first need to be applied to package design in deciding shapes, sizes, ventilation and cooling of produce in boxes. Next comes choice of styles to facilitate all aspects of handling. It is only after these steps have been considered that the structural design aspects of package development come into play.

The following are the basic design and engineering considerations:

(1) Ability of the package to withstand rough handling, some level of which is unavoidable in the distribution system. This is referred to as containment strength;

(2) Ability of the package to support the stacking loads imposed in transport and storage operations; and

(3) Ability of the package to resist distortion, such as bottom sag and container bulge.

Containment strength may be provided through choice of style, package components and special additions such as tension tapes/strings, etc., but above all by overhauling the distribution system and handling methods and thus minimising the hazards which cause the need for extra strength. Fork lift handling and containerisation have been major advances in this regard.

It is in considerations 2 and 3, however, that the greatest advances have been made in recent times. Properly engineered packages can provide improved performance at lower cost, through optimum choice of components and their disposition within the structure of the box.

Traditionally Australia has manufactured waste-paper based linerboards, which have good stacking properties but suffer by comparison with virgin fibre grades. Containability is less because tear strength is lower, and ability to cope with high humidity conditions is also less.

In June 1985, APM introduced a new range of Kraft Liner Boards which have since taken over the bulk of the local market. They contain a blend of long fibre for adequate containability and creasing quality, and short eucalypt fibre for high stacking strength, and are also significantly lower in price than the superseded grades.

Complementary to this was the introduction of a virgin fibre corrugating medium — Supafute 180, to join the range of mediums from low-crush 120 gsm (for use in wraparound situations where no stacking strength is required, but conformability in high-speed packaging machinery is vital), through a general-purpose 117 gsm product, to high performance 155 gsm and ultimately, the Supafute 180.

Performance of boxes, with regard to stackability

* Product Manager — Container Materials, Australian Paper Manufacturers, 685 Bourke Road, Camberwell, Vic 3124, Australia.

and bulge resistance, is largely controlled by the inside liner and the medium of the corrugated board selected. Thus it is still valid to use waste-based White Liners on the outside for enhanced graphics and market appeal without loss of box performance, and this is one of the fastest growing sections of the box market.

High stress conditions such as high or cycling humidities and long-term storage of heavy boxes in stacks, can be allowed for by extra wet-strengthening, or treatment with wax or resin.

Even well-designed boxes encounter problems from overfilling, and from poor pallet stacking and alignment, and it is necessary for the Packaging

Engineer to allow safety factors of 4, 5 or even 10 times the actual stacking requirements of a box, to cope with the real world situation.

In summary, good packaging will: protect the product and reduce waste and damage; reduce process and handling time in plant and equipment; facilitate handling and automatic processing; facilitate inventory control and order-picking; allow full utilisation of available warehouse space; ease normal handling and inspection procedures; contribute to conservation and recycling of materials; promote product market image; meet statutory regulations; facilitate price-marking, shelf-loading and similar operations, and enhance user convenience.

Transfresh System of Atmosphere Control

Glen Adams *

THE following specifications, taken from one particular contract, indicate the capabilities and construction of the Transfresh atmosphere control system:

(1) Design Parameters

(a) Room dimensions:

Width: 10 255–12 400 mm

Depth: 11 200 mm

Height: 3000 mm

(b) Insulation:

150 mm walls and ceiling; no floor insulation

(c) Product load:

Nine pallets of various produce to be pressure-cooled in 6–8 hours from 32 to 1°C.

Average specific heat .92 BTU/lb.

(d) Ambient temperature:

40°C dry bulb, 29°C wet bulb

(e) Room temperatures:

0–15°C maintaining average humidity levels of 95–96%

(2) Refrigeration equipment

Each room has the following installed:

(a) Air handler:

Thermfresh model HH18F high humidity air handler, constructed with a 20 mm marine ply casing which is fibreglassed inside and out after fabrication.

The evaporator is a multi-circuited copper tube bare pipe evaporator, electro-tinned after fabrication. Two backward curved fans are mounted at each end of the cabinet, and have a total air flow of 18 000 CFM.

The heart of the system is the fill, which has been designed to obtain maximum heat transfer with the air and water which pass in a counter-flow direction through the fill (patent pending).

Water is recirculated within the air handler by means of a high volume, close-coupled pump.

Excess water in the air that has passed through the air handler is totally removed by means of eliminators mounted on top of the cabinet.

Height of air handler: 2480 mm.

(b) Condensing unit:

Thermpak model NT15–2 × 15 package condensing unit, factory-assembled, processed and precharged with refrigerant. The unit is prewired so that on delivery to the site it only requires the suction and liquid lines to be installed, and interconnecting wiring to be completed.

(c) Construction:

Channel steel base with square tube steel frame, all galvanised after construction. The frame is then weatherproofed with a colorbond steel case, with access doors for service.

(d) Compressors:

Terry model 1000B multi-cylinder reciprocating compressors, each with splash feed lubrication, and belt-driven by 15 HP, 3φ electric motors. The compressors are 100% unloaded on start, and are fitted with HP and LP controls.

(e) Condensers:

C.T.S. model RC 160 air-cooled condensers, each constructed with a copper tube aluminium fin core and aluminium outer casing.

(f) Controls and fittings:

Liquid line driers

Liquid line moisture indicators

Liquid line solenoid valves

Discharge mufflers

Thermostatic expansion valves

Ice Bank thermostat

* Co-ordinated Thermal Systems Pty Ltd, Refrigeration Engineers and Designers, 42 Henderson Road, Clayton VIC 3168, Australia.

(g) Electrical panel:

Comprising HRC fuses, motor starters and overloads, delay timers, phase failure relay, hour run meters, neon indicator lights for faults, and mains isolating switch. Panel mounted switches are provided so that each system can be shut down on a pump-down cycle when not required.

(h) System capacity:

178 908 BTU/hour (52.3 kW) with an air-off temperature of 0.5°C.

(3) Remote control panel

Installed in a convenient position within the complex, and incorporating the following:

(a) Kent model P250 12-point recorder (250 mm chart)

(b) Probes for recorder

(c) Room thermostats — Shimaden electronic resistance bulb

(d) System isolating switches

The panel is constructed with a stainless steel front, and a steel main frame powder-coated after fabrication.

(4) Buffer strips and blinds

Buffer strips fitted around pressure cooling openings, manufactured with a foam rubber insert covered with heavy duty reinforced PVC sheeting.

Pressure cooling blinds also manufactured from reinforced PVC sheeting with timber battens at 1-m intervals.

Trials have been conducted with this system on apples shipped to the United Kingdom, blueberries, nectarines and pears shipped to the United States, and honeydew melons shipped to Hong Kong; also avocados shipped from Mexico. Comparative trials with honeydew melons indicated that with refrigeration the fruit arrived in good condition and had the standard 7 days shelf life; with modified atmospheres the fruit were also in good condition and had an extra 14 days of shelf life, and with controlled atmospheres the fruit were again in good condition and had an additional 21 days of shelf life.

The controlled atmosphere system costs A\$1150 extra, the modified atmosphere A\$750 extra; in both cases this is on top of the cost of refrigeration. There is no cost of gases to be added to the shipment; the gases are generated by the product, and the system merely controls the ratios and levels of the gases. The controller is accurate to $\pm 0.5\%$. A teledyne sensor is used for oxygen measurement. The maximum acceptable leakage of the system is 7 min half decay time.

Participants

The following list includes many of the persons who attended the workshop. However, because of the diversity of groups interested in the subject, the meeting was widely advertised and open to anyone who wished to attend, and not all names were recorded.

- G. Adams**, Co-ordinated Thermal Systems Pty Ltd., Refrigeration Engineers and Designers, 42 Henderson Road, Clayton, VIC 3168.
- J. Aiken**, Principal Consultant, Compass Consulting Services, 5/20 Cliff Street, Milsons Point, NSW 2061.
- Garth Atkinson**, Department of Primary Industry, PO Box 417, Konedobu, Papua New Guinea (current address: ACIAR, GPO Box 1571, Canberra, ACT 2601).
- J.D. Baker**, Secretary, Sydney Market Authority, PO Box 2, Flemington Markets, NSW 2129.
- H.J. Banks**, CSIRO Division of Entomology, GPO Box 1700, Canberra, ACT 2601.
- B. Beattie**, New South Wales Department of Agriculture, PO Box K220, Haymarket, NSW 2000.
- G.R. Chaplin**, CSIRO Division of Food Research, PO Box 52, North Ryde, NSW 2113.
- S. Cole**, CSIRO Division of Food Research, PO Box 52, North Ryde, NSW 2113.
- M. English**, Avocado Growers Association of New South Wales, Main Arm, Mullumbimby, NSW 2482.
- P. Ferrar**, ACIAR, GPO Box 1571, Canberra, ACT 2601.
- J. Forsyth**, New South Wales Department of Agriculture, PO Box K220, Haymarket, NSW 2000.
- D. Graham**, CSIRO Division of Food Research, PO Box 52, North Ryde, NSW 2113.
- G. Hicks**, New South Wales Department of Agriculture, PO Box K220, Haymarket, NSW 2000.
- T.O.D. Hughes**, Transport Consultant, Queensbury Pty. Ltd., 5 Shinfield Avenue, St. Ives, NSW 2075.
- A.R. Irving**, CSIRO Division of Food Research, PO Box 52, North Ryde, NSW 2113.
- L.B. James**, Product Manager-Container Materials, Australian Paper Manufacturers, 685 Bourke Road, Camberwell, VIC 3124.
- A.R. Johnson**, Officer-in-Charge, CSIRO Food Research Laboratory, PO Box 52, North Ryde, NSW 2113.
- R.A. Jordan**, Queensland Department of Primary Industries, Sandy Trout Food Preservation Laboratory, Hamilton, QLD 4007.
- E.E. Kavanagh**, CSIRO Division of Food Research, PO Box 52, North Ryde, NSW 2113.
- T. Limbert**, Banana Growers' Federation Co-operative Limited, PO Box 31, Murwillumbah, NSW 2484.

- B. McGlasson**, CSIRO Division of Food Research, PO Box 52, North Ryde, NSW 2113.
- S. Morris**, New South Wales Department of Agriculture, Gosford Horticultural Postharvest Laboratory, PO Box 355, Gosford, NSW 2250.
- R. Parkes**, Director of Cargo, Qantas Airways Limited, GPO Box 489, Sydney, NSW 2001.
- B.C. Peacock**, Queensland Department of Primary Industries, Sandy Trout Food Preservation Laboratory, Hamilton, QLD 4007.
- I.D. Pegg**, Victorian Department of Agriculture and Rural Affairs, Knoxfield Horticultural Research Institute, PO Box 174, Ferntree Gully, VIC 3156.
- G.J. Persley**, Research Program Coordinator (Crop Sciences), ACIAR, GPO Box 1571, Canberra, ACT 2601.
- T. Pilavachi**, Terry's Export Produce Pty. Ltd., Market Plaza, Flemington, NSW 2129.
- S. Satyan**, CSIRO Division of Food Research, PO Box 52, North Ryde, NSW 2113.
- K.J. Scott**, New South Wales Department of Agriculture, C/- CSIRO Food Research Laboratory, PO Box 52, North Ryde, NSW 2113.
- A.K. Sharp**, CSIRO Division of Food Research, PO Box 52, North Ryde, NSW 2113.
- L. Shepherd**, Cargo Standards Manager, Qantas Airways Limited, GPO Box 489, Sydney, NSW 2001.
- W.J. Singleton**, Banana Growers' Federation Co-operative Limited, PO Box 31, Murwillumbah, NSW 2484.
- S. Spraggons**, CSIRO Food Research Laboratory, PO Box 52, North Ryde, NSW 2113.
- B.L. Tugwell**, Senior Research Officer, Postharvest Horticulture, South Australian Department of Agriculture, Northfield Research Laboratories, Box 1671, Adelaide, SA 5001.
- N.L. Wade**, New South Wales Department of Agriculture, C/- CSIRO Food Research Laboratory, PO Box 52, North Ryde, NSW 2113.
- C. Warisaiho**, Department of Primary Industry, PO Box 417, Konedobu, Papua New Guinea.
- B.L. Wild**, Senior Research Horticulturist, Gosford Horticultural Postharvest Laboratory, PO Box 355, Gosford, NSW 2250.

ACIAR PROCEEDINGS SERIES

- No. 1. Proceedings of the Eastern Africa-ACIAR consultation on agricultural research, Nairobi, Kenya, 19–22 July 1983. J.G. Ryan (ed.), 241 p., 1984.
- No. 2. Proceedings of the international workshop on soils, Townsville, Qld., Australia, 12–16 September 1983. E.T. Craswell and R.F. Isbell (ed.), 189 p. 1984.
- No. 3. Shrub legume research in Indonesia and Australia; proceedings of an international workshop, Ciawi-Bogor, Indonesia, 2 February 1984. E.T. Craswell and Budi Tangendjaja (ed.), 42 p., 1985.
- No. 4. Proceedings of the Nigeria-Australian seminar on collaborative agricultural research, Shika, Nigeria, 14–15 November 1983. S. Nuru and J.G. Ryan (ed.), 145 p., 1985.
- No. 5. Evaluation of large ruminants for the tropics; proceedings of an international workshop held at CSIRO, Rockhampton, Queensland, Australia, 19–23 March 1984. J.W. Copland (ed.), 178 p., 1985.
- No. 6. Soil erosion management: proceedings of a workshop held at PCARRD, Los Baños, Philippines, 3–5 December 1984. E.T. Craswell, J.V. Remenyi, and L.G. Nallana (ed.), 132 p., 1985.
- No. 7. Goat production and research in the tropics: proceedings of a workshop held at the University of Queensland, Brisbane, Australia, 6–8 February 1984. J.W. Copland (ed.), 118 p., 1985.
- No. 8. Tropical legume improvement: proceedings of a Thailand/ACIAR planning and coordination workshop, Bangkok, 10–12 October 1983. G.J. Persley (ed.), 77 p., 1985.
- No. 9. Smallholder rubber production and policies: proceedings of an international workshop held at the University of Adelaide, South Australia, 18–20 February 1985. 151 p., 1985.
- No. 10. Draught animal power for production: proceedings of an international workshop held at James Cook University, Townsville, Qld, Australia, 10–16 July 1985. J.W. Copland (ed.), 170 p., 1985.
- No. 11. Agricultural systems research for developing countries: proceedings of an international workshop held at Hawkesbury Agricultural college, Richmond, N.S.W., Australia, 12–15 May 1985. J.V. Remenyi (ed.), 189 p., 1985.
- No. 12. Forages in Southeast Asian and South Pacific agriculture: proceedings of an international workshop held at Cisarua, Indonesia, 19–23 August 1985. G.J. Blair, D.A. Ivory, and T.R. Evans (ed.), 202 p., 1986.
- No. 13. Bacterial wilt disease in Asia and the South Pacific: proceedings of an international workshop held at PCARRD, Los Baños, Philippines, 8–10 October 1985. G.J. Persley (ed.), 145 p., 1986.
- No. 14. Pesticides and humid tropical grain storage systems: proceedings of an international seminar, Manila, Philippines, 27–30 May 1985. B.R. Champ and E. Highley (ed.), 364 p., 1986.
- No. 15. Preserving grain quality by aeration and in-store drying: proceedings of an international seminar held at Kuala Lumpur, Malaysia, 9–11 October 1985. B.R. Champ and E. Highley (ed.), 250 p., 1986.
- No. 16. Australian acacias in developing countries: proceedings of an international workshop held at the Forestry Training Centre, Gympie, Qld., Australia, 4–7 August 1986. John W. Turnbull (ed.), 196 p., 1987.
- No. 17. Ticks and tick-borne diseases: proceedings of an international workshop on ecology of ticks and epidemiology of tick-borne diseases, held at Nyanga, Zimbabwe. 17–21 February 1986. R.W. Sutherst (ed.), 159 p., 1987.
- No. 18. Food legume improvement for Asian farming systems: proceedings of an international workshop held at Khon Kaen, Thailand, 1–5 September 1986. E.S. Wallis and D.E. Byth (ed.), 341 p., 1987.
- No. 19. Technological change in postharvest handling and transportation of grains in the humid tropics: proceedings of an international seminar, Bangkok, Thailand, 10–12 September 1986. B.R. Champ, E. Highley, and J.V. Remenyi (ed.), 208 p., 1987.
- No. 20. Management of wild and cultured sea bass/barramundi (*Lates calcarifer*): proceedings of an international workshop held at Darwin, N.T., Australia, 24–30 September 1986. J.W. Copland and D.L. Grey (ed.), 210 p., 1987.
- No. 21. Banana and plantain breeding strategies: proceedings of an international workshop held at Cairns, Australia, 13–17 October 1986. G.J. Persley and E.A. De Langhe (ed.), 187 p., 1987.
- No. 22. Bulk handling and storage of grain in the humid tropics: proceedings of an international workshop held at Kuala Lumpur, Malaysia, 6–9 October 1987. B.R. Champ and E. Highley (ed.), 299 p., 1988.