



**AgEcon** SEARCH  
RESEARCH IN AGRICULTURAL & APPLIED ECONOMICS

*The World's Largest Open Access Agricultural & Applied Economics Digital Library*

**This document is discoverable and free to researchers across the globe due to the work of AgEcon Search.**

**Help ensure our sustainability.**

Give to AgEcon Search

AgEcon Search

<http://ageconsearch.umn.edu>

[aesearch@umn.edu](mailto:aesearch@umn.edu)

*Papers downloaded from **AgEcon Search** may be used for non-commercial purposes and personal study only. No other use, including posting to another Internet site, is permitted without permission from the copyright owner (not AgEcon Search), or as allowed under the provisions of Fair Use, U.S. Copyright Act, Title 17 U.S.C.*

*No endorsement of AgEcon Search or its fundraising activities by the author(s) of the following work or their employer(s) is intended or implied.*

RURAL ECONOMIC DEVELOPMENT IN MANITOBA\*

J.A. MacMillan

January 1987

**Department of Agricultural Economics  
and Farm Management  
University of Manitoba  
Winnipeg, Manitoba  
R3T 2N2**

RURAL ECONOMIC DEVELOPMENT IN MANITOBA\*

J.A. MacMillan

January 1987

---

\*Prepared for a seminar discussion, Department of Agricultural Economics, North Dakota State University, Fargo, North Dakota, January 23, 1987.

January 1987

RURAL ECONOMIC DEVELOPMENT IN MANITOBA\*

J.A. MacMillan  
Department of Agricultural Economics and Farm Management  
University of Manitoba

Rural economic development in the context of this discussion is broadly defined to include all public and private sector activities which have a significant impact on income and employment opportunities, as well as social development in rural Manitoba. Often the importance of public services such as highways, health, welfare and education in generating job and income opportunities is neglected in discussions of rural economic development. It is not recognized that such activities generate a large proportion of regional economic activity and have a critical impact on the economic development of rural regions. Furthermore, the smaller the size of the rural regional economy, the greater the magnitude of "spillover benefits" to major metropolitan regions and national urban industrial complexes generated by increasing rural region economic activity.

Rural development projects are initiated based on a narrow view of regional jobs created without considering whether or not it is the best regional project assuming job creation is the major rural development objective. For example, evaluations of irrigation and other agricultural projects are often completed within a narrow benefit/cost analytical framework ignoring the macroeconomic relations

---

\*Prepared for a seminar discussion, Department of Agricultural Economics, North Dakota State University, Fargo, North Dakota, January 23, 1987.

affecting rural regions. Perhaps this narrow perspective of many rural development programs underlies the major shift away from Canadian rural economic development programs to massive Canadian public expenditures on transfers including agricultural subsidies, stabilization and financial rescue operations. Rural development programs in Canada and Manitoba have largely been displaced by income stabilization programs such as the Western Grain Stabilization Program, payments to dairy farmers, special assistance to grain producers and farmers in financial difficulty.

The thesis of this paper is that public and private rural development activities will have a significant improvement in effectiveness if impacts are analyzed relative to quantitative and qualitative rural region economic development indicators and "spillover benefits" to major metropolitan centers and national regions are documented. Standard management principles can be applied to achieve improvement relative to economic development indicators. Key management tasks include: 1) measuring regional economic development objectives, 2) constructing a regional economic model permitting base case forecasts of rural region economic development without new initiatives, 3) regional impact analysis of new initiatives, and 4) follow-up evaluations.

Rural economic development in Manitoba is discussed below with respect to the following four major topics: 1) evolution of rural and regional development policies, 2) rural region economic development analysis, strategies, approaches and models, 3) rural development

program evaluations and impact analyses, and 4) a proposed framework for rural development analysis in Manitoba.

#### 1. Evolution of Rural and Regional Development Policies

Canada's first rural development program, the Agriculture Rehabilitation and Development Act (ARDA), was introduced in 1961 in response to the unacceptable levels of poverty in numerous rural communities.<sup>1</sup> ARDA began as a federal/provincial effort to improve incomes of rural areas by initiatives focussing on increasing productivity of small farmers and providing assistance for alternative uses of marginal land. Other programs emphasized increasing work opportunities in rural areas, developing water and soil resources and fisheries. The early ARDA legislation was heavily criticized for its primary focus on natural resource adjustment as a means of reducing rural poverty.<sup>2</sup>

In 1966 ARDA was renamed the Agricultural and Rural Development Act and the objectives and programs were broadened to include nonagricultural sectors in rural areas to absorb surplus rural labour. To provide a focus for the rural area programs, the Fund for Rural Economic Development (FRED) was introduced in 1966 to apply in designated rural regions (Interlake-Manitoba, Gaspé-Quebec, Mactaquac-New Brunswick) which had widespread low incomes and major problems of

---

<sup>1</sup>D.J. Savoie, Regional Economic Development: Canada's Search for Solutions, Toronto: University of Toronto Press, 1986.

<sup>2</sup>H. Buckley and E. Tihanyi, Canadian Policies for Rural Adjustment: A Study of the Economic Impact of ARDA, PFRA, and MMRA, Ottawa: Economic Council of Canada, 1967.

economic adjustment. Comprehensive development plans were formulated for the rural regions.

In 1968 under the Liberal government leadership of Pierre Elliot Trudeau, increasing priority was given to regional development. The Department of Regional Economic Expansion (DREE) was set up to co-ordinate federal efforts in regional development to focus on infrastructure (roads, water and sewer systems and schools) focussing on growth centers in special area programs and industrial incentives (cash grants to processing and manufacturing firms) in designated areas (Savoie, p. 29). A policy review in the early 1970's rejected the growth center and industrial incentive focus of DREE and initiated broad 10 year General Development Agreements with all provinces. The Agreements were to focus on federal/provincial co-operation in selecting development projects across all sectors (Savoie, p. 59).

Another review in 1978 resulted in the establishment of the Ministry of State for Regional Economic Development (MSERD) to co-ordinate and direct federal economic development policy. Unhappy with joint federal/provincial regional formulation of programs with provincial delivery, the federal government established 10 year Economic and Regional Development Agreements (ERDA's) in 1981 to promote direct delivery of projects by the federal government as well as joint federal/provincial implementation of initiatives (Savoie, p. 81). The current Manitoba ERDA agreement signed in 1983 includes a priority for transportation, human resources, and strengthening small businesses. Regional development was to be a concern of each sectoral department. The latest governmental reorganization changed the

Regional Economic Expansion agency into the federal Department of Regional Industrial Expansion to co-ordinate funding for a new Industrial and Regional Development Program with funding based on a development "index" for census districts.

Canadian rural development program expenditures amounted to \$1.1 billion in the 1969-76 period.<sup>3</sup> In the mid Seventies, increasing agricultural prosperity led to a focus on income stabilization programs to commodity groups on a continuing basis to dairy farmers, and more recently to grain producers. The federal/provincial expenditures on rural and regional development in Manitoba in the late 1960's and early 1970's were several times the magnitude of current rural and regional development expenditures. The current agricultural development agreement in Manitoba was structured in 1984 to spend \$38.3 million on a five-year agri-food development agreement. The objective of the agreement is to "enhance the efficient production and marketing of crops and livestock, improve the management of the province's soil and water resources, and help farmers boost their management skills."

## 2. Rural Region Economic Development Analyses Strategies, Approaches and Models

While rural development programs are generally designed and implemented with reference to economic efficiency criteria, income stabilization programs and other short-term subsidies are generally

---

<sup>3</sup>J.A. MacMillan and G.R. Winter, "Income Improvement Versus Efficiency in Canadian Rural Development Programmes," Proceedings of the Seventeenth International Conference of Agricultural Economists, 1979, pp. 381-88.

nonproductive and recognized by economists to promote inefficient resource allocations by farmers relative to a welfare oriented policy such as a negative income tax. Evaluations of current rural and regional development programs are not published but based on prior rural economic development evaluations in Manitoba it is very probable that an increase in rural development programs substituting for some of the current short-term subsidy programs of hundreds of millions of dollars in Manitoba would have a greater long-term benefit to Manitoba farmers.

The purpose of this section is to illustrate an approach to rural regional development analysis and modelling. Strategies are discussed below with respect to two dimensions: 1) FRED Plan evaluation process, and 2) synthesis of regional economic accounts and special studies.

Governments are often reluctant to support independent objective evaluations. It is politically safer not to collect the appropriate data and depend on partisan advocates and beneficiaries for testimonial assessments. Academics on the other hand are often reluctant to get involved in applied economic policy evaluations due to the effort required to provide results useful to policy makers. Federal government administrators observed that it was not possible to assess the success or failure of other FRED Plans in Canada relative to the success of the Interlake Plan due to the absence of evaluation research on plans in other areas.

## 2.1. FRED Plan Evaluation Process

A contract was initiated with Dr. J.C. Gilson, Department of Agricultural Economics at the University of Manitoba and the FRED Plan administration to provide base support for an evaluation of the Plan to be carried out over the 10 year period. The base support provided salary and minimal research dollars of \$250,000 per year. Critical features of the evaluation research process are summarized below:

1) The objective of the evaluation was to provide the FRED Board with facts and data to permit an administrative impact assessment on programs.

2) With the assistance of Dr. W.R. Maki and Dr. J.R. Barnard, a framework for the regional economic development evaluation was outlined in 1968 and subsequently published<sup>4</sup> which ensured a long-term perspective and framework for a series of complementary studies.

3) The base funding was complemented by support from academic research sources and FRED Board support for base data and special studies on manpower services, land clearing and farm development amounting in total to about \$800 thousand which was less than 1 percent of the total FRED budget of \$85 million.

4) The research budget is understated due to the low cost of graduate students' research inputs (6 Ph.D., 11 M.Sc., 4 Natural Resource Institute Practicums and 6 person-years of full-time research associate inputs).

---

<sup>4</sup>J.R. Barnard, J.A. MacMillan and W.R. Maki, "Evaluation Models for Regional Development Planning," Regional Science Association Papers 23(1969):117-40.

5) Advisory committees made up of academics leave residents and government planners ensured that the results of research studies were timely and useful to plan administrators reversing the standard academic approach of searching for problems to fit theoretical models. Research publications in academic journals were not a problem for the policy makers and added significant credibility to the results.

## 2.2. Synthesis of Regional Economic Accounts and Special Studies

An attempt was made to provide quantitative measures consistent with the broad plan objectives: average income levels, income distribution, consumption expenditures, return on investment geographical mobility, employment, occupational mobility and preservation of natural resource stocks (Figure 1). Special studies were undertaken to link FRED Plan programs—highways, recreation, manpower services, land acquisition, drainage, land clearing, and resource management—to program performance measures and regional economic relations summarized in a regional input-output model. The program performance measures—miles of road, park visitor days, manpower clients, farm sales and wildlife population—were used in the traditional context of public program monitoring. Highway planners, drainage engineers and recreation specialists monitor their performance by physical measures not economic development objectives. Special studies focussed on the physical performance measures, project economic efficiency measured by benefit/cost ratios for projects and income distribution impacts measured by the income level of program clients. The input-output model was used to translate the program

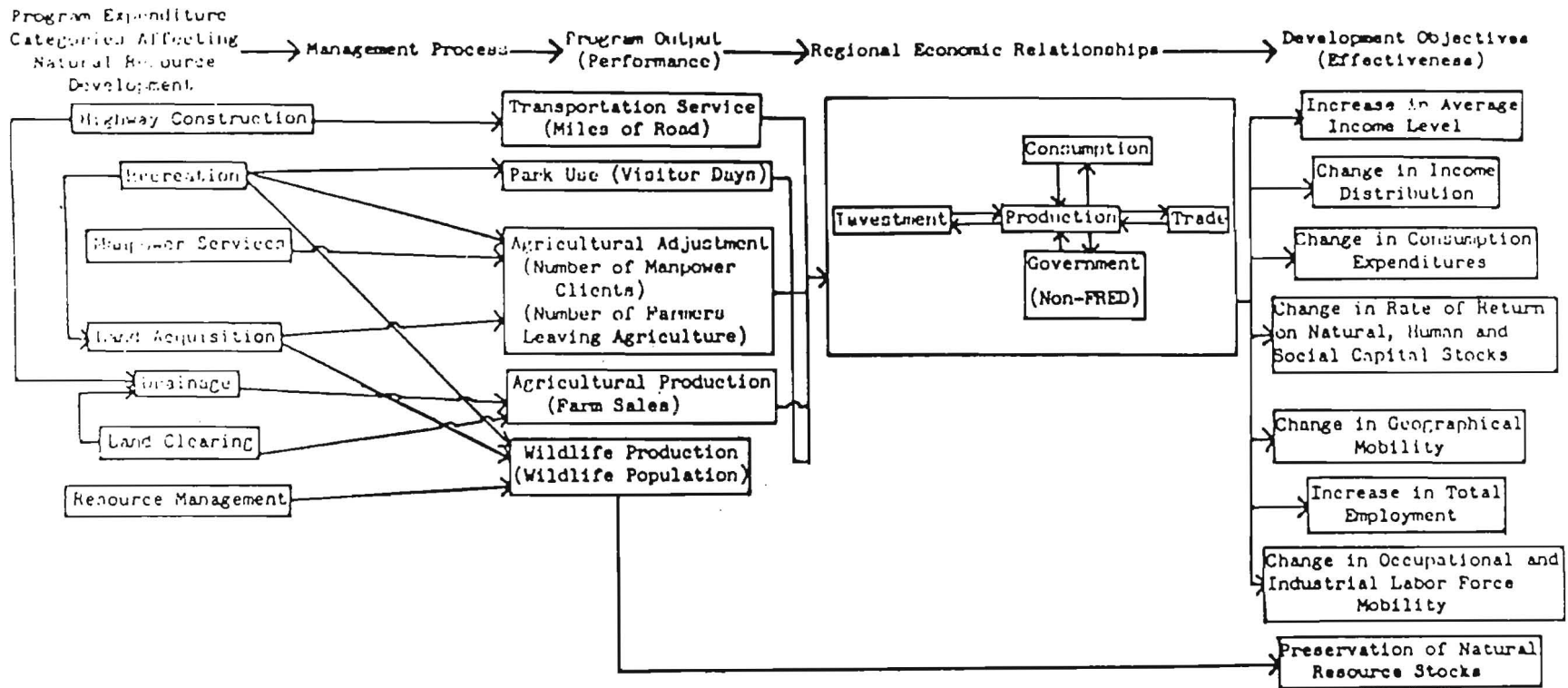

Source: James A. MacMillan, Chant-mei Lu and Charles F. Framingham, Manitoba Interlake Area: A Regional Development Evaluation (Ames: Iowa State University Press) 1975, p. 16.

Figure 1

FRED Program Management Interrelationships,  
Economic Relationships, and Development Objectives

expenditure data into aggregate impact measures of regional income and employment.

The scarcity of research on rural development planning prevents strong conclusions on the payoff to expenditures on most rural plans. Ideally, the six steps outlined in Figure 2 could be applied in several rural regions and results compared and the reliability of the approach assessed. General agreement on the necessity of the individual steps is required. Using the business management analogy, quantitative measures are required relative to general policy goals. For example, many economists in reviewing Canadian regional rural development policies, particularly the FRED Plans, disagreed with the focus on improving the income and standards of living of the people in the Interlake. In contrast, a focus on national economic efficiency was considered more appropriate. Consistent with a focus on national economic efficiency, policies would be introduced to assist out-migration from low income regions and from the agricultural sector. It is interesting to note that an indirect effect of the strong emphasis on investments in human resources in the Interlake through adult education, skill training and general upgrading of the region's secondary school system and improvements in the road system was to stimulate out-migration from the region even though out-migration was not a specific policy goal.

Agreement is also necessary on the focus of combining special studies on specific projects and programs with a regional model. Studies are required on both an ex-ante and ex-post basis to conform to basic scientific research methods. The regional accounting

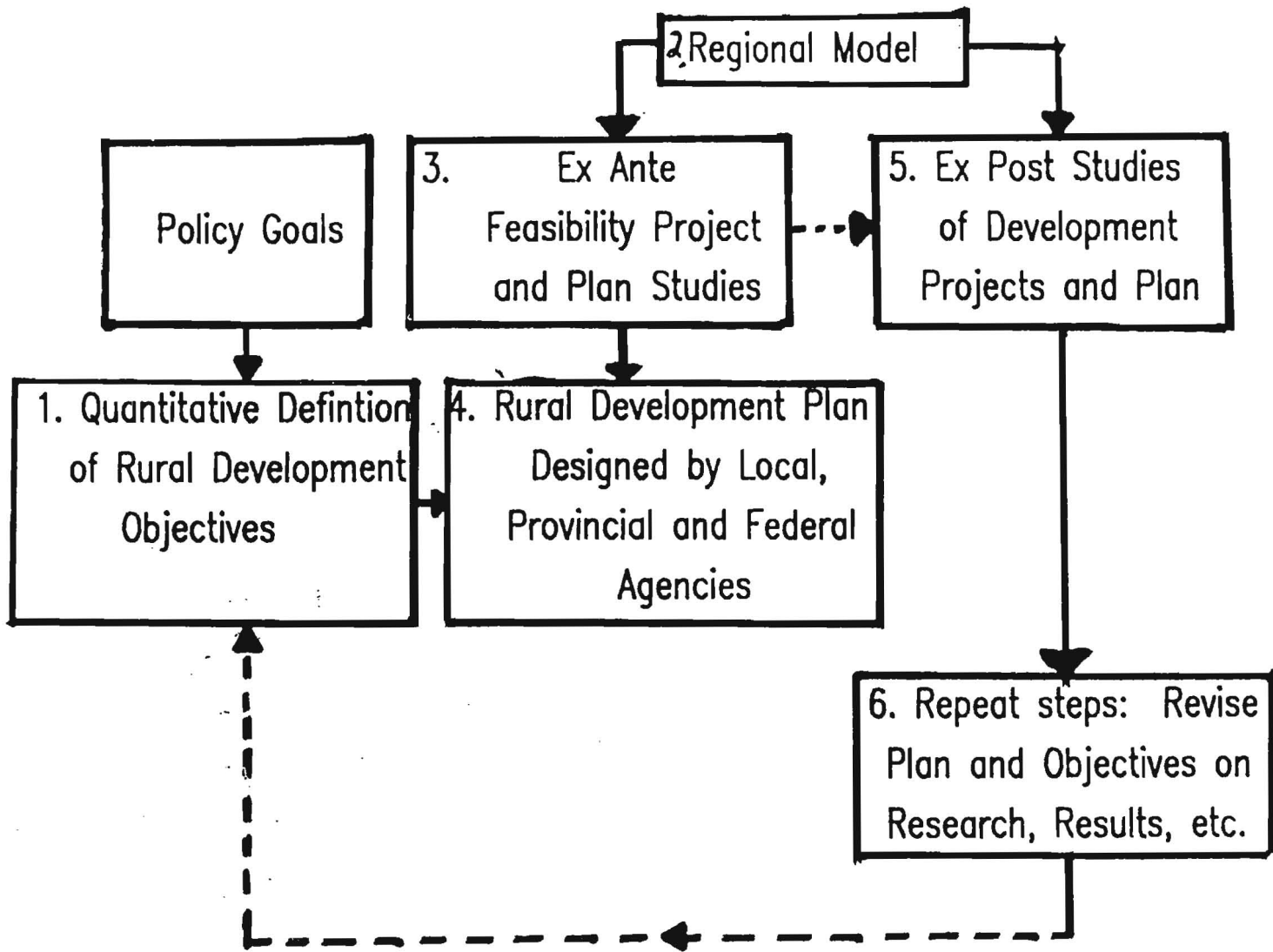

Source: James A. MacMillan and J.D. Graham, "Rural Development Planning a Science?" American Journal of Agricultural Economics 60(5, 1978):945-49.

Figure 2  
Rural Development Planning Research Activities

framework provides a summary of the major economic forces affecting regional economic development and growth. Again using the experimental method analogy, regional accounts measure the regional economic environment within which the Plan operates. In the Interlake case, the regional accounts approach paid off significantly when the federal Department of National Defence decided to close the air base in the region. The regional model substantiated the conclusion that the annual negative impacts of the air base closure were very close to the total annual FRED Plan impacts. Efforts were made to offset the air base closure with industrial incentives to stimulate nonfarm job opportunities in the region.

Another major benefit of the regional accounts approach is the documentation of linkages and "spillover benefits" to other provincial regions, other provinces and the national economy. For example, in a Manitoba context, the 1979 value of farmgate production was \$1.4 billion which is directly linked to \$1.4 billion of food processing activities (60 percent of this food processing activity is located in Winnipeg). In addition, every dollar of farm income in rural regions stimulated by rural development is associated with indirect and induced economic activity in western Canadian regional centers, Ontario and Quebec in Eastern Canada. The critical feature of linkages relative to rural development is that spillover benefits from agricultural and resource development programs occur in major regional centers and national regions. However, "spillover benefits" to rural regions from development of regional centers and national regions are minimal.

The specification of local, provincial and federal inputs and agreement on the Plan's programs and projects is consistent with modern management principles which advocate participation by workers in business decisions as a means of ensuring success as opposed to the difficulties associated with autocratic management methods. It is not reasonable to expect rural people to collaborate in the achievement of rural development objectives imposed by authorities outside the region. In fact, it is to be expected that local groups would initiate actions to ensure the Plan fails if their participation is not included in the Plan.

### 3. Rural Development Program Evaluations and Impact Analysis

The FRED Plan for the Interlake Region of Manitoba can be viewed as an experiment in comprehensive rural region economic development planning. The broad objectives of the Plan were to promote economic development of the Interlake, to increase income and employment opportunities, and to raise the standard of living of the people. Programs were implemented in areas of education, manpower, agriculture, fisheries, transportation and recreation. A total of \$85 million was allocated to the FRED Plan over the 1967-77 period: adult education (\$27.3 million), schools and education (\$26.7 million), resource improvement (\$29.4 million), and administration (\$1.7 million).

The Plan was a unique experiment in management of rural development initiatives.<sup>5</sup> Co-ordination was provided by a provincial co-manager from the Manitoba Department of Agriculture and a federal co-manager from the Department of Regional Economic Expansion. The co-managers reported annually to a Canada-Manitoba Joint Federal-Provincial Advisory Board made up of senior government personnel primarily at the Deputy Minister level. The Plan expenditures were administered by eight Manitoba government departments. Local participation was formalized through Area Development Boards which were instrumental in developing local political support for specific programs and projects for several years prior to the initiation of the Plan.

The FRED Plan evaluation, as well as transportation and drought sensitivity impact analyses, are discussed as illustrative examples of rural development research in Manitoba. The synthesis of special studies and regional economic accounts was a common focus of the research. In the transportation study, the rural development policy focus was directed to an examination of the negative impacts on provinces associated with rail line abandonment and rate increases. The drought sensitivity study was directed to assessing alternative strategies to reduce negative impacts on provinces of a prolonged drought. The results and procedures used in these studies are summarized below.

---

<sup>5</sup>See R.J. Hordo and J.A. MacMillan, "An Assessment of FRED Plan Management in the Interlake Area of Manitoba," Canadian Journal of Agricultural Economics 24(No. 1, 1976):33-39.

### 3.1. FRED Program Evaluation Results and Regional Impacts

FRED program evaluation results are summarized with respect to human resources, natural resources and infrastructure expenditures.<sup>6</sup> The objectives of the human resource development program was to improve the public school system, increase job opportunities and incomes. School consolidation was completed and 610 new classrooms were constructed for primary and secondary education. Adult education was provided by the following: academic upgrading (2,578 persons), job training assistance (5,460 persons), and manpower corps (2,321 persons).

Benefit-cost analysis of the manpower services indicated: 1) graduates of the farm management, training in industry, and vocational and special training programs had the best opportunity to raise their level of income and employment; 2) upgrading programs such as manpower corps provided social benefits as well as income and employment generation; 3) substantially higher incomes were realized by those participating in the mobility and job referral programs, and 4) people who were helped by the program were primarily in the lower income categories.

For manpower corps participants, it was estimated that the unemployment rate of trainees dropped from 80 percent to 19 percent and that the average weekly earned income rose from \$82 to \$219.

---

<sup>6</sup>See J.A. MacMillan and S. Lyon, The Interlake Experience: A Description and Evaluation of a Rural Development Program, 1967-77, Department of Agricultural Economics and Farm Management, University of Manitoba, Occasional Series No. 9, December 1977.

After eight years, benefits derived were three times the training cost and after 10 years, the benefits derived were five times the cost.

The farm development program and the fisherman development program were primarily educational programs. Both programs were intended to assist lower income farmers and fishermen to raise their incomes and to achieve a greater degree of income security by increasing their management and technical skills. There were 385 participants in the farm development program and 375 in the fisherman development program during the 1972-76 period. Farmers who participated in the farm development program and increased their existing dairy and/or hog operations, recorded an increase in overall returns from livestock production. The timeframe of the data on observed clients only extends to over a one to two year period; therefore, the full impact had not been realized at the time of the study.

Under the natural resource development programs, land development, drainage and land adjustment, as well as parks and recreation facilities were initiated. Over the six years (1967-73) that the land development program was in operation, an additional 126,346 acres of land were cleared, primarily for forage purposes, at an expenditure of \$700,000. Analysis of land clearing indicated that the present value of gross receipts equalled clearing costs after three years. Eighty percent of the farmers were cropping their cleared land three years after clearing. Of those farmers participating, 70 percent had gross receipts of less than \$10,000 indicating that the land clearing program was important to small or lower income farmers.

A total of 140 miles of drainage channels were reconstructed at a total of \$7 million. Net income associated with additional acres of crops and improved pasture existing after drainage was estimated to have a present value to costs ratio of 3:1. A large proportion of drainage benefits went to the larger higher income farms.

Under the land adjustment program, 54,655 acres classified as "poor" were purchased and converted to alternate uses such as wildlife refuges and parks at a cost of \$4 million. The primary purpose was to remove low capability land out of production. Of the 324 land owners involved, most felt that they had benefited from the program. The parks recreation program was directed to the provision of construction and training jobs immediately and service jobs in the future at a cost of \$4.3 million.

Regional infrastructure was required to facilitate development under other programs. A total of 402 miles of provincial roads and highways were improved and reconstructed at a cost of \$48.8 million to facilitate school consolidation and provide an east-west link across the Interlake. Other infrastructure projects included a parks furniture construction training-in-industry plant at \$500 thousand, four veterinary clinics at a cost of \$120 thousand and a farm water services assistance of \$300 thousand to 1,923 farmers.

It is not possible to summarize the total benefits of all FRED programs in a single number such as income flow per year because the benefits of increased high school attendance and local community leadership result from all programs. In addition, it is commonly acknowledged that development program effects require a gestation

period of more than nine years. It is significant that the Interlake area is no longer one of Canada's lowest income rural areas. Impacts associated with \$20 million of the total \$85 million expenditures on agriculture and recreation were estimated using a regional simulation model (Figure 3). A comparison of forecasts for 1976 with and without the \$20 million in FRED programs resulted in: 1) a \$10.3 million total income flow to Interlake residents, about \$200 per person per year, 2) employment, 1.4 thousand person years, and 3) gross output, \$27 million.

The Interlake evaluation analysis and other program evaluations are summarized below in Table 1 in terms of the cost effectiveness of \$1 million public rural development expenditure. Care is required in interpreting the results. A proportional relationship is implied between expenditure and job creation. Initial capital expenditure costs and employment impacts are omitted for drainage, recreation, education and manpower corps projects. The food processing example is based on the assumption of a DREE grant of \$1.4 million for rapeseed processing being the sole basis of the processing employment change. The table provides the type of information required to assess the impacts of rural development expenditures. From a long-term development perspective, agricultural development expenditures and manpower corps projects have the highest job creation impacts per \$1 million public expenditure. It is also important to note that the Interlake is a relatively high moisture area with a predominance of forage and livestock production.

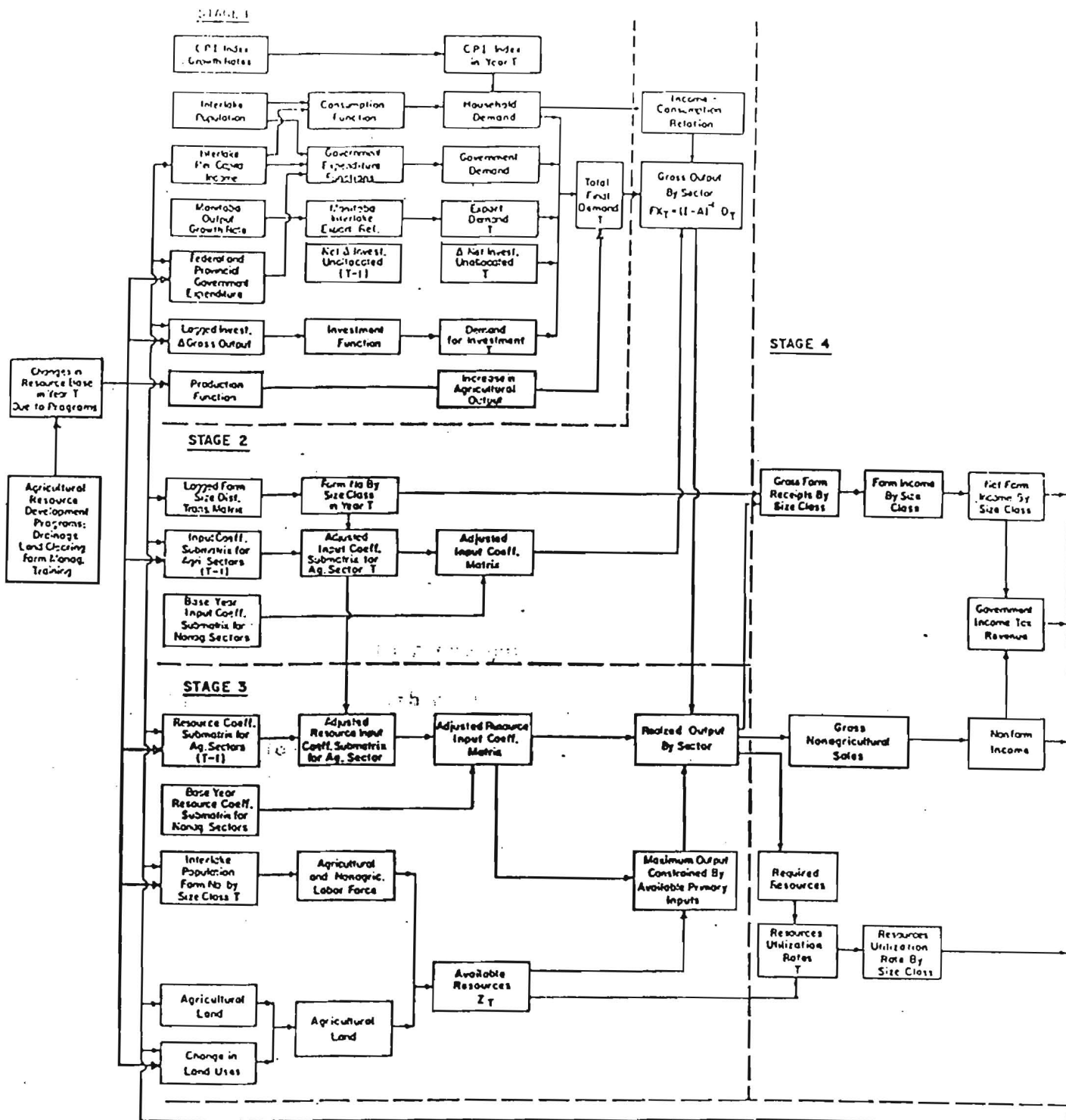

N.B. The heavy solid line indicates the second step of the simulation procedures in which the effects of agricultural resource development programs are indicated in the related stages of the simulation procedure. The light solid line presents the first step of the simulation procedures.

Source: F.L. Tung, J.A. MacMillan and C.F. Framingham, "A Dynamic Model for Evaluating Resource Development Programs," American Journal of Agricultural Economics 58(3, 1976):403-14.

Figure 3

A Diagrammatic Presentation of the Modified Simulation Model

Table 1

Job Creation Per \$1 Million in Alternative Rural Development Programs  
Interlake Region, Manitoba

Sectoral Program	Man-Years Employment Created Per \$1 Million (1968 Dollars)	Timing of Job Impact
1. Agricultural Development <sup>a</sup>	160	Perpetual or Life of Drain
2. Food Processing <sup>b</sup>	50	Perpetual
3. Education <sup>c</sup>	85	Annual Expenditure Required
4. Housing <sup>d</sup>	80	Annual Expenditure Required
5. Highways <sup>e</sup>	30	Annual Expenditure Required
6. Recreation (Annual Expenditure) <sup>f</sup>	60	Annual Expenditure Required
7. Manpower Corps <sup>g</sup>	160	For the Working Life of Trainees

20

<sup>a</sup>Estimated from analysis of agricultural development programs by F.L. Tung, J.A. MacMillan and C.F. Framingham, "A Dynamic Regional Model for Evaluating Resource Development Programs," American Journal of Agricultural Economics 58(No. 3, 1976):403-14. Drainage, land clearing and farm management training, \$8.4 million, generated 1.4 thousand man-years of employment.

<sup>b</sup>A \$1.4 million in DREE industrial incentives for a rapeseed processing plant is estimated to generate 47 plant jobs and 20 trade centre jobs. J.A. MacMillan, et al., "Parklands Region Manpower Information Study," Unpublished Report, Department of Agricultural Economics, University of Manitoba, 1974, pp. 514-21.

<sup>c</sup>The 1968 Interlake education expenditures of \$7.4 million create 635 jobs, 536 man-years of employment in the school system and 99 trade center jobs. P. Molgat and J.A. MacMillan, Education in Area Economic Development (Winnipeg, Manitoba: Centre for Settlement Studies, University of Manitoba), 1972.

<sup>d</sup>J.A. MacMillan and E. Nickel, "An Economic Appraisal of Urban Housing Assistance--Rental Supplements Versus Public Housing," Canadian Public Administration 17(No. 3, 1974):443-60.

<sup>e</sup>P.G. Douglas and J.A. MacMillan, Simulation of Economic Impacts of Highway Expenditures, Research Report No. 9 (Winnipeg, Manitoba: Centre for Transportation Studies, University of Manitoba), 1972.

<sup>f</sup>The job impact is calculated per \$1 million of operating expenditures at Hecla Provincial Park, \$700 thousand in 1976. the capital cost of \$5 million is excluded. N.Brown and J.A. MacMillan, "Recreational Program Development Impacts: A Dynamic Regional Analysis," American Journal of Agricultural Economics, November 1977.

<sup>g</sup>The \$5 million manpower corps expenditures 1967-76 increased wages from \$82 to \$219 per week and reduced the unemployment rate from 80 percent to 20 percent after training for 1,300 trainees resulting in an investment of 160 jobs. Marco Fernandez, "Evaluation of Manpower Training Programs: The Interlake Manpower Corps," Ph.D. Thesis, 1977.

### 3.2. Transportation Impact Analysis

Several models incorporating transportation, agricultural production and dynamic regional input-output accounts were synthesized as part of a study of the role of transportation in regional economic development (Figure 4). The grain handling and distribution system model included: costs of moving grain from farms to elevators, cost of operating elevators, and redistribution of farmer delivery patterns to elevators due to rail route changes. A regional linear programming model for Manitoba's agriculture incorporated a variety of crop and livestock products and intermediate demand by the livestock sector for feed grains. Farm size, soil type, regional and provincial demand for each commodity and farm transport costs in shipping commodities to various locations in Manitoba were included. Changes in the level and distribution of agricultural output, as measured by the programming model, had impacts on the regional economy. These impacts were measured through use of the dynamic input-output model for the Interlake area. Impacts associated with changing farm expenditures on trucking and rail rates, as well as decreasing expenditures by elevator and rail companies were estimated. The results (Tables 2 and 3) and the estimated regional effects provide measures of the impacts of transportation on rural economic development.

### 3.3. Drought Sensitivity Analysis

The drought sensitivity analysis was funded under the Canada-Manitoba Interim Subsidiary Agreement on Water Development for Regional Economic Expansion and Drought Proofing. The Agreement falls under the 10 year Canada-Manitoba General Development Agreement of

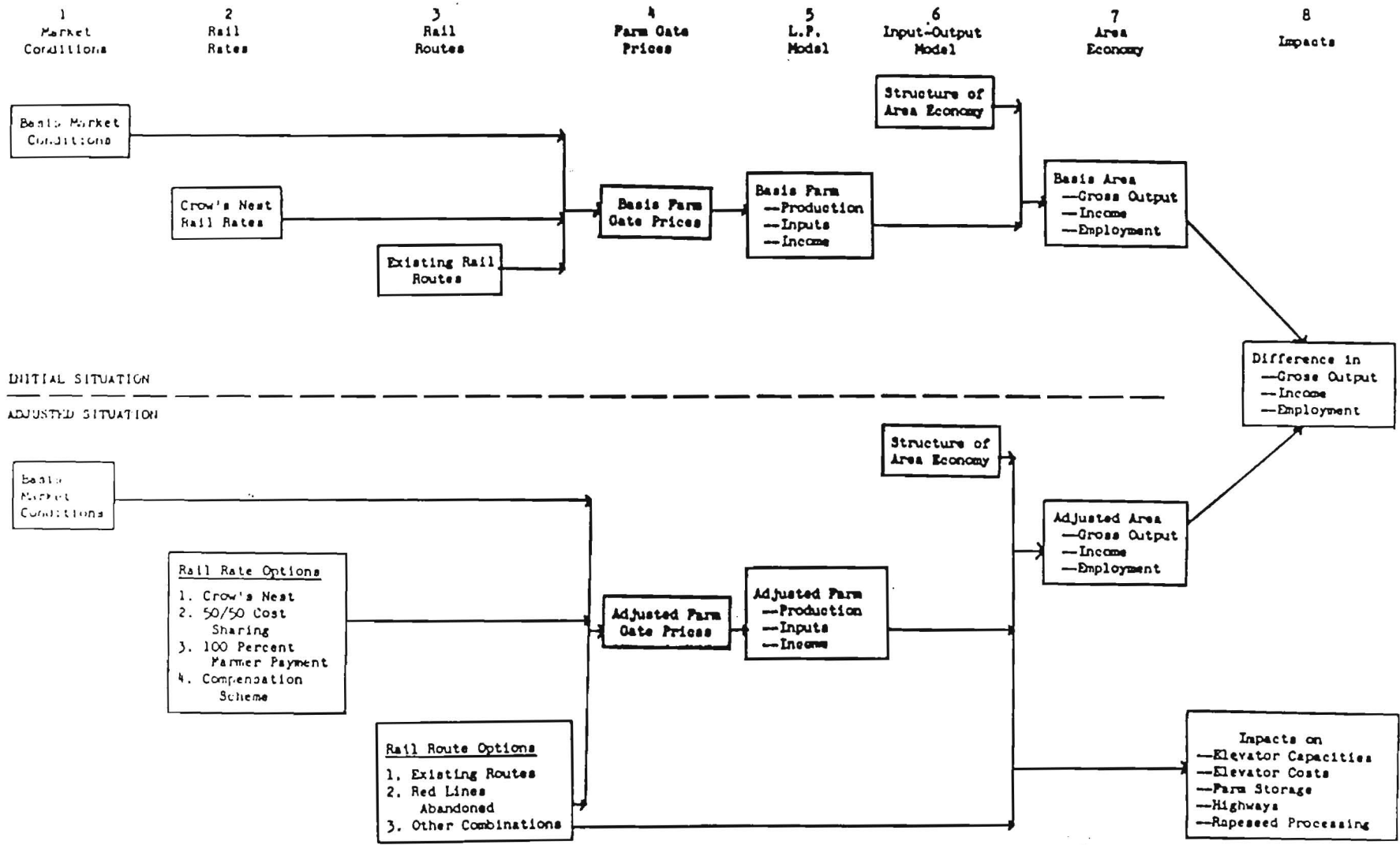

Source: E.W. Tyrczniewicz, C.F. Framingham, J.A. MacMillan and J.W. Craven, "The Abandonment of Uneconomic Branch Lines and Unremunerative Grain Rates: Effects on Agriculture and Regional Development," *Logistics and Transportation Review* 14(1978):411-31.

Figure 4

Transportation Options and Rural Development

Table 2

Effect of Changes in Rail Routes in Manitoba as  
a Result of Hall Commission Recommendations

	1973-74 Scenario	1970-71 Scenario
No. of Producers Affected	2,515	2,515
Increase in Farm Trucking Costs		
- total	\$248,511	\$165,470
- average per bushel	\$0.022	\$0.02
Increase in Trucking Cost per Producer Affected		
- average	\$99	\$66
- range	\$28 - \$198	\$12 - \$187
Loss in Elevator Capacity	3,552,500 bushels	
Average Capacity Lost per Producer Affected	1,588 bushels	
Decrease in Elevator Operating Costs	\$1,063,000	\$1,203,000
Effect of Rail Rate Changes in Manitoba From Present Statutory Rates to Compensatory Rates (Farmers Pay 100 Percent of "Snively" Costs)		
Increase in Rail Costs to Farmers		
- total for province	\$12,666,000	\$17,672,000
- per bushel	\$0.13	\$0.13
- per producer		
average	\$410	\$572
range	\$34 - \$1,242	\$47 - \$1,726

Table 3  
Effect of Route and Rate Changes Combined  
1973-74

---

Change in Farm Trucking Cost due to Route Changes	\$249,000
Change in Rail Cost due to Route Changes	-\$15,000
Change in Rail Cost due to Rate Changes	<u>\$17,672,000</u>
Change in Cost	
- total	\$17,906,000
- per bushel	13.2
- per producer	\$579
- range	\$46 - \$1,708

---

Source: E.W. Tyrchniewicz, et al. "The Abandonment of Uneconomic Branch Lines and Unremunerative Grain Rates: Effects on Agriculture and Regional Development," Logistics and Transportation Review, 1978, p. 411-31.

June 1974. Major areas and opportunities for economic development in southern Manitoba, outside Winnipeg, are identified including the diversification of agriculture, improvement of rural trade and service centers and the encouragement of employment participation. Mitigating drought impacts and improving existing water supply were considered essential to facilitate expansion of agricultural production. Considerable attention was paid to linked activities such as food processing, manufacturing of farm inputs and other farm services.

An overview of the model structure used in analyzing mitigation of drought impacts is given in Figure 5. Various scenarios were supplied by the Study Management Committee which included government representatives. Prices, transportation systems, and soil types were held constant with climate and technologies (no till, summerfallow and change in irrigation) as exogenous factors varied in the analysis. Temperature and precipitation of various weather conditions are translated into soil moisture deficits for various crops on different soil types. A second series of models determines the yield impact of the moisture deficits which were in turn modelled in the Aggregate Crop Production Model. A livestock simulator is used to determine aggregate levels of sales of livestock, nonfeed input costs, nutritional requirements and capital replacement.

Agricultural commodity production and input information was used in the input-output model to trace impacts on the nonfarm sectors in terms of indirect production and employment. The Statistics Canada inter-provincial input-output model was modified to treat agriculture as an exogenous sector determined by the linear programming production

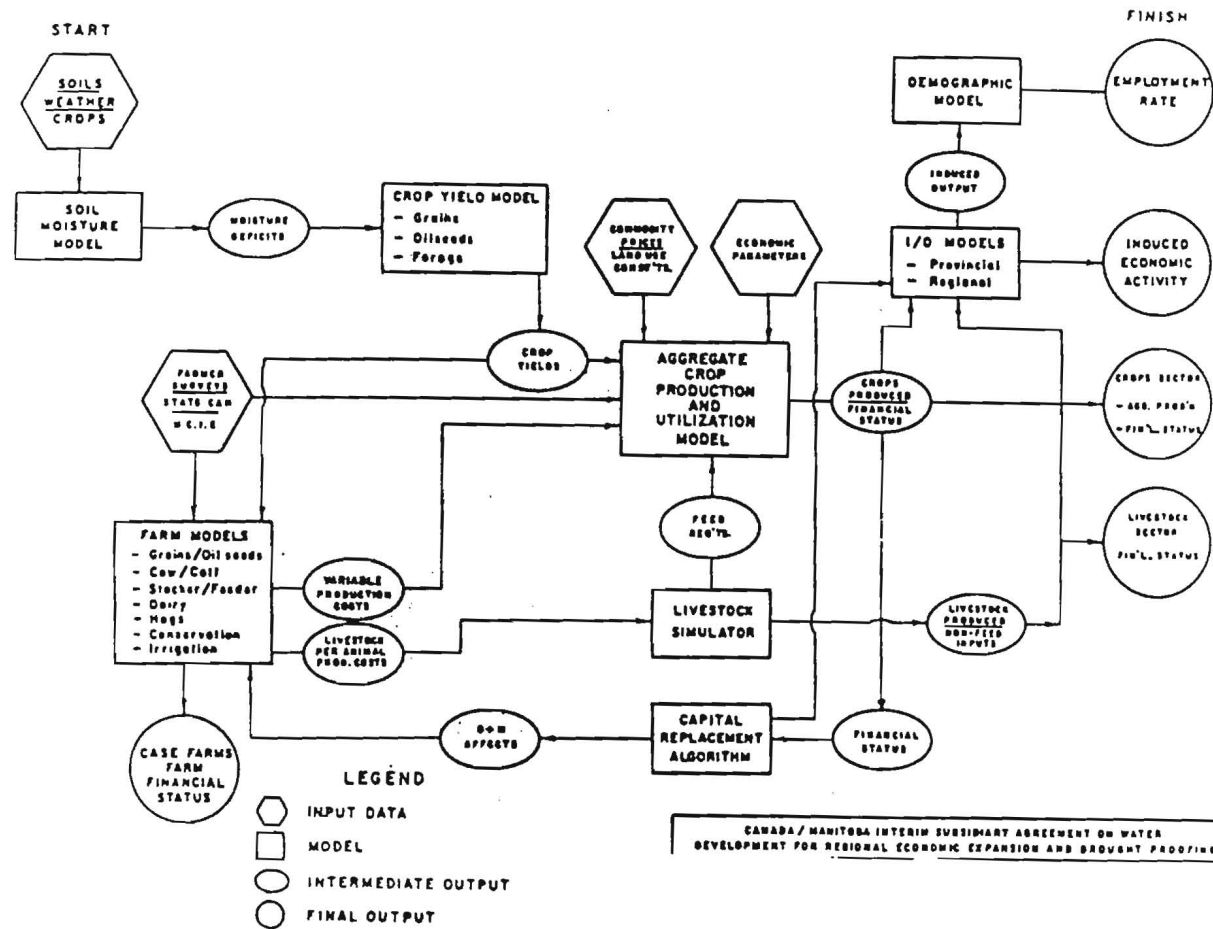

Source: L.M. Arthur and D. Freshwater, Analysis of the Economic Prolonged Agricultural Drought in Manitoba, Department of Agricultural Economics, University of Manitoba, Research Bulletin 86-2, 1986.

Figure 5  
Drought Sensitivity Analysis  
Model Array

activities. A series of farm models simulate representative farms calculating costs and returns, cash flow, balance sheets, and income statements for each type of enterprise given a set of representative management practices and initial inventory. The farm models provide information on production constraints and climate impacts on financial structure.

Drought scenarios were designed to examine alternatives for stabilizing the Manitoba economy under prolonged periods of drought. Only conservation tillage with winter wheat showed any stabilizing effect and reducing summerfallow to promote increasing production created a destabilizing effect. Irrigation provided no stabilizing effect during drought despite stability of production due to high costs of irrigating and marketing constraints on irrigated crop production. Only corn was selected by the linear programming model for irrigation. New varieties and technologies, including increased summerfallowing, have worked towards attenuating drought impacts in Manitoba. The drought sensitivity analysis illustrates a procedure for calculating rural development impacts associated with negative environmental changes.

#### 4. A Proposed Framework for Rural Development Analysis in Manitoba

Rural development policies in Manitoba have evolved from a period of minimal public expenditures on agriculture in the early 1960's to the current situation of massive income transfers to farmers. In the mid 1960's, a co-ordinated comprehensive effort at rural development planning in the Interlake was initiated. In the late 1970's and

1980's to date, rural development and analysis has been characterized by an extreme absence of co-ordination. Policy responses have been to provide subsidies on a reactive basis in response to major rural problems of transport system rationalization, droughts and current problems of financial difficulty and low grain prices. A proposal is outlined which highlights the opportunity for achieving rural development objectives by reallocating some public farm subsidy expenditures to economic development initiatives.

#### 4.1. A Proposed Framework

The first requirement in rural economic analysis is to establish a set of measures for assessing progress with respect to rural region economic development. Three broad groups of indicators are suggested in Figure 6: 1) income growth, 2) percent of families below poverty income "cut-offs," and 3) public service quality and access (e.g., education, health, recreation, etc.). The framework suggests that there are three major categories of rural economic development expenditures and initiatives: 1) economic development programs, 2) direct subsidies, stabilization and financial rescue policies to low income rural groups, and 3) public service expenditures which can be used to achieve improvements in rural economic development indicators. Major economic benefits result from co-ordinating expenditures and reallocating expenditures to high "pay-off" programs as analysis and evaluation information accumulates.

The major political benefit of using direct farm subsidies is the speed of delivery. Economic development programs require a substantial start-up and delivery period. The major disadvantage of

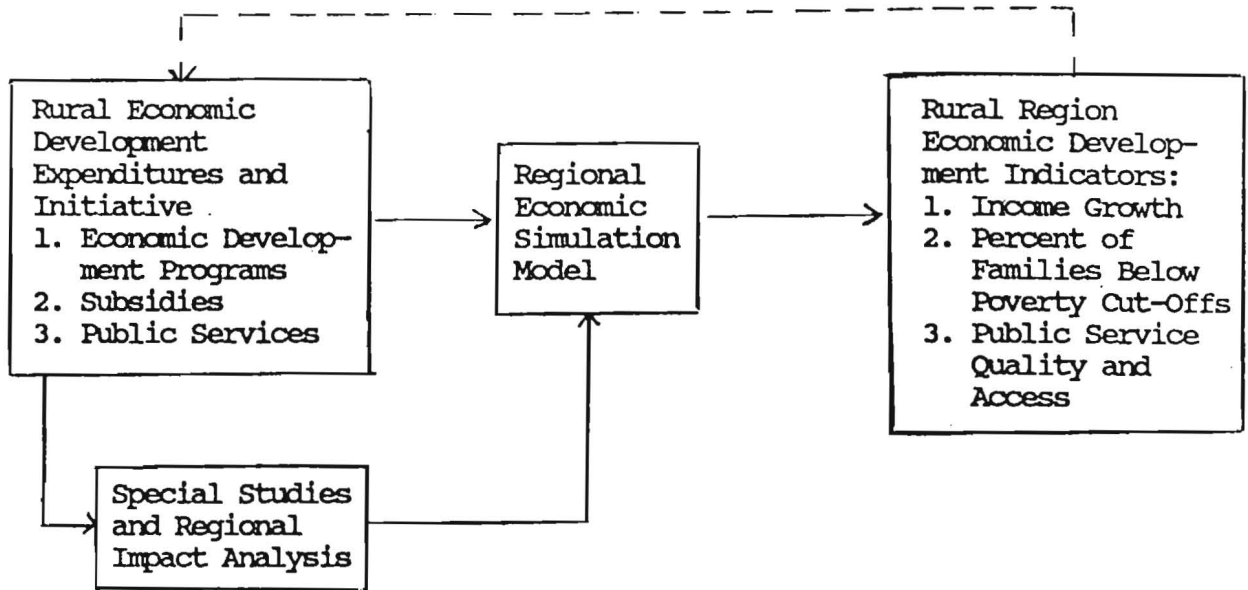

Figure 6

A Proposed Framework for Rural Economic Development Analysis

current subsidies is the waste of public funds on recipients who are "well off" and treat the subsidy as a windfall income receipt to be spent on consumption expenditures instead of investments which will lead to future rural regional income growth. An improvement would result if payments were "targeted" solely to low income farmers.

A critical problem with the rural economic development framework is that policy makers and rural development analysts are not experienced in the selection of profitable rural region investment opportunities. A high degree of economic efficiency illiteracy exists with respect to the selection of public projects which would qualify as superior investments, hence creating increasing future income and employment opportunities in rural areas. Clearly, the research and economic procedures for examining alternative programs and projects relative to the quantitative measures of rural region economic development are available. To accurately assess the productivity impact of "subsidies" versus economic development projects, estimates of the investment expenditures if any associated with subsidies are required. One missing essential critical ingredient is the institutional framework representing federal, provincial and local interests required to achieve co-ordinated comprehensive rural development planning and implementation. In the FRED Plan context, the co-ordinating responsibility at the policy level came from politicians through the FRED Board and administrative co-ordination was achieved by federal and provincial co-managers in collaboration with line departments of the Manitoba government and local Area Development Boards in the Interlake.

#### 4.2. Rural Region Economic Development Indicators

A list of rural region economic development indicators is outlined in Table 3. Income growth requires a broad range of income generating profitable investment opportunities which can be transformed into development programs and projects. Two other categories of development indicators can also be viewed as constraints to development. Depending on the composition of the rural region's export base commodities, income growth can be characterized by wide swings associated with export commodity price cycles and general economic recessions. The classification of the FRED programs under human and natural resource development implies that the public investments in training, land development and drainage have a "pay-off" in terms of future regional income growth. Economic analysis will permit a ranking of projects relative to their future "pay-off" measured in terms of future income growth.

A fourth major indicator of rural development is the level of rural "poverty" which indicates the necessity for welfare assistance. Lastly, public service access and quality can be viewed as "quality of rural living" indicators. Everyone would like to have ready access to the "better" medical and recreational facilities and services.

#### 4.3. Rural Economic Development Expenditures and Initiatives in Manitoba

Rural economic development expenditures and initiatives in Manitoba are summarized in Table 4. Three major categories of programs exist: 1) subsidy programs, 2) economic development programs, and 3) public service programs. Estimates indicate that the

Table 4

Rural Economic Development Expenditures  
and Initiatives in Manitoba

---

---

1. Subsidy Stabilization and Financial Rescue	Special Canadian Grains Program Western Canadian Grains Program Crop Insurance Dairy Income Support Other Commodity Stabilization Programs Drought Assistance Subsidized Credit: FCC and MACC Manitoba Farm Family Protection Act (including farm debt adjustment subsidies)
2. Economic Development Programs	Prairie Farm Rehabilitation Act Economic and Regional Development Agreement: Agriculture and Trade and Technology Agricultural Research and Demon- stration: Manitoba Department of Agriculture, Agricultural Experiment Stations, Agriculture Canada, University of Manitoba, Faculty of Agriculture, Agri- business Canada Employment Commission: Training and Mobility Assistance and Rural Transition Program Transportation Programs and Policies
3. Public Services	Health, Welfare, Education, Recreation, Municipal Affairs and National Defense

---

---

1986 level of transfers to farmers in Manitoba is in the range of \$300 to \$400 million (Figure 7) which is many times the level of economic development programs. The \$1.9 billion "receipts" measure of gross market returns to farmers is estimated by subtracting stabilization, crop insurance, etc., from the standard total farm revenue measure which includes transfer payments. The market measure is overstated to the extent marketing board "rents" are not deducted. The market oriented "net income" is calculated by subtracting transfers from receipts. Transfers in 1987 will be about \$150 million larger with the special Canadian Grains Program. In contrast, rural economic development programs are in the range of \$30 million.

There is an obvious opportunity to increase the future level of rural economic development in Manitoba by increasing rural economic development expenditures as a substitute for some subsidy expenditures. The FRED Plan evaluation, drought sensitivity and transportation studies illustrate the type of analysis required. The policy trade-off is between nonproductive transfer subsidies versus rural economic development programs such as farm management training, nonagricultural training and mobility assistance, resource development, agricultural research, etc., which, if effectively planned, have a potential to improve future income levels in Manitoba's rural regions. To the extent "spillover benefits" are greater for productive rural economic development projects than nonproductive subsidies future income flows to Winnipeg and the economies of Ontario and Quebec will be enhanced.

Manitoba, 1984 - 1986

35

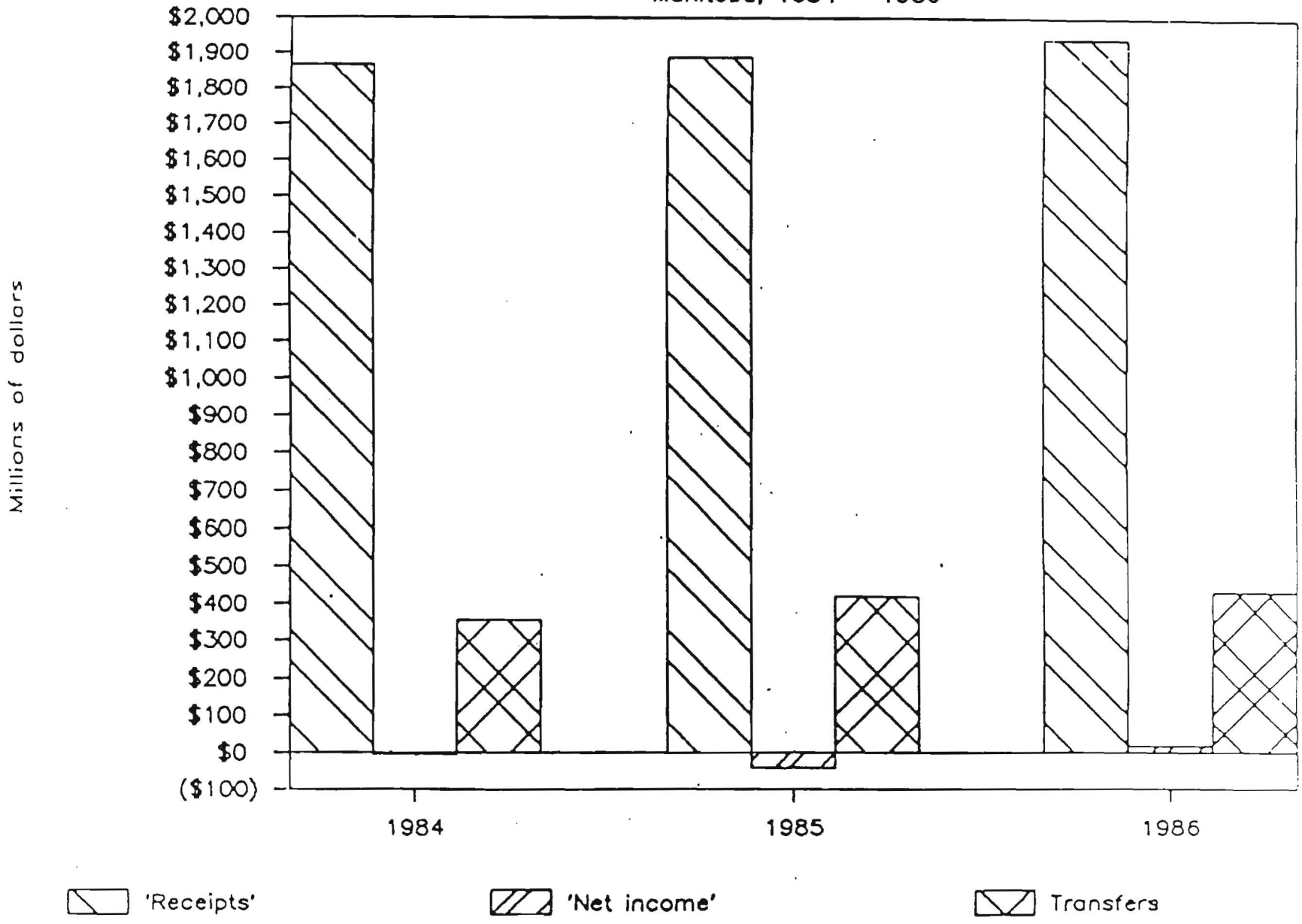

Source: Agriculture Canada, Winnipeg, Manitoba.

Figure 7  
Market Returns Versus Government Payments

