



AgEcon SEARCH

RESEARCH IN AGRICULTURAL & APPLIED ECONOMICS

The World's Largest Open Access Agricultural & Applied Economics Digital Library

This document is discoverable and free to researchers across the globe due to the work of AgEcon Search.

Help ensure our sustainability.

Give to AgEcon Search

AgEcon Search

<http://ageconsearch.umn.edu>

aesearch@umn.edu

*Papers downloaded from **AgEcon Search** may be used for non-commercial purposes and personal study only. No other use, including posting to another Internet site, is permitted without permission from the copyright owner (not AgEcon Search), or as allowed under the provisions of Fair Use, U.S. Copyright Act, Title 17 U.S.C.*

No endorsement of AgEcon Search or its fundraising activities by the author(s) of the following work or their employer(s) is intended or implied.

Sustaining Surface and Groundwater Resources

**PROCEEDINGS OF
THE INTERNATIONAL WORKSHOP ON**

**Conjunctive Water Management for
Sustainable Irrigated Agriculture in South
Asia**

**April 16-17, 2002
Lahore, Pakistan**

Asad Sarwar Qureshi, Ayesha Bhatti & Waqar A. Jehangir, editors



International Water Management Institute

IWMI receives its principal funding from 58 governments, private foundations, and international and regional organizations known as the Consultative Group on International Agricultural Research (CGIAR). Support is also given by the Governments of Ghana, Pakistan, South Africa, Sri Lanka and Thai Land.

The conjunctive water management project aimed to identify combinations of institutional and technical strategies to manage surface and groundwater at regional scale to promote environmental sustainability and maximize agricultural productivity of water ('crop per drop'). Two major semi arid irrigated areas, Rechna Doab in Pakistan and Murrumbidgee Region in Australia were chosen for this study. This project was funded by ACIAR, and executed with the technical collaboration of CSIRO, Australia. The local collaborators in Pakistan were Pakistan Council for Research in Water Resources (PCRWR), Soil Salinity Research Institute (SSRI) and Ayub Agricultural Research Institute (AARI).

The editors: Asad Sarwar Qureshi is Acting Director for IWMI Regional Office for Pakistan, Central Asia and Middle East. Ayesha Bhatti is technical editor and Waqar A. Jehangir is senior agricultural economist. Both also belong to the International Water Management Institute.

Qureshi, A. S., Bhatti, A. and Jehangir, W. A. 2002. Managing Surface and Groundwater Resources: Proceedings of the International Workshop on Conjunctive Water Management for Sustainable Irrigated Agriculture in South Asia. Lahore: International Water Management Institute.

IWMI gratefully acknowledges the secretarial support of Muhammad Iqbal Khan in the preparation of the proceedings.

Keywords: water management / conjunctive use / water resources / water quality / waterlogging / salinity / private sector / groundwater development / land resources / intensive cropping / productivity / returns / surface water / agriculture / environmental sustainability / crops / irrigated farming / geology / sedimentation / tube wells / crop yield / Rechna Doab

ISBN: 92-9090-492-5

Please direct inquiries and comments to: iwmi-pak@cgiar.org or IWMI 12 Km, Multan Road, Chowk Thokar Niaz Baig, Lahore 53700 Pakistan

Copyright © 2002, by IWMI. All rights reserved.

CONTENTS

Foreword	iii
PART I - INAUGURAL SESSION.....	1
Welcome Address	3
Dr. Asad Sarwar Qureshi	
IWMI's Global Research Themes	5
Dr. Hammond Murray-Rust	
ACIAR Research Priorities and CSIRO Land and Water Irrigation Research	9
Dr. Evan Christen	
Inaugural Address by the Chief Guest	11
Dr. Badruddin Soomro	
PART II - MODELING ASPECTS OF CONJUNCTIVE WATER MANAGEMENT	17
Conjunctive Water Use and Conjunctive Water Management	19
Hammond Murray-Rust	
Conjunctive Water Management for Sustainable Irrigated Agriculture in Rechna Doab: An Overview and Progress of Research Work.....	25
Waqar A. Jehangir	
Role of Surface and Groundwater in Meeting Crop Water Demand in Intensive Agriculture Systems Using a Nodal Network Approach	29
M. Kaleem Ullah, Shahbaz Khan, Evan Christen, and H. M. Nafees Ahmad	
Modeling Approaches to Quantify the Water Balance in Groundwater-Dominant Irrigation Systems - An Example of Rechna Doab Pakistan.....	45
S. Khan, M. Kaleem Ullah, E. Christen and H. M. Nafees Ahmad	
Controlling Groundwater Tables Through Localized Sub-Surface Evaporation Basin: A Case Study of Rechna Doab	61
H. M. Nafees Ahmad, M. Kaleem Ullah and Asad S. Qureshi	
Modeling the Effects of Conjunctive Water Management on Secondary Salinization.....	73
Asad Sarwar Qureshi and Ilyas Masih	
PART III - TECHNICAL ASPECTS OF CONJUNCTIVE WATER MANAGEMENT	83
Conjunctive Use of Water Resources for Integrated Water Resources Management (IWRM) –Integrating Spatial Analysis and Innovative Geomatics Techniques.....	85
Wolfgang-Albert Flügel	

Soil Salinity / Sodicity and Ground Water Quality Changes in Relation to Rainfall and Reclamation Activities	91
Nazir Hussain, Fakhar Mujeeb, Ghulam Sarwar, Ghulam Hassan and M. Kaleem Ullah	
Requirements and Constraints for Sustainable Shallow Groundwater Pumping for Salinity Control in Irrigated Areas	101
Evan Christen and Shahbaz Khan	
Artificial Recharge Basin Siting: Verification of GIS Approach Through Geophysical Investigations	109
G. M. Shah, H. M. Nafees Ahmad, Asghar Hussain and Abdul Razzaq	
Remote Sensing and GIS Based Analysis of Conjunctive Water Use in the Rechna Doab, Pakistan.....	119
Mobin-ud-Din Ahmad and Wim G.M. Bastiaanssen	
Conjunctive Use of Water: Impact on Soil and Crops	133
Muhammad Ramzan Chaudhry and Muhammad Nawaz Bhutta	
PART IV - ECONOMICAL/INSTITUTIONAL ASPECTS OF CONJUNCTIVE WATER MANAGEMENT.....	147
Water Institutional Arrangements Under Water Scarcity.....	149
Vilma Horinkova	
Trade-Offs Between Gross Farm Income, Groundwater and Salinity at Irrigation Sub-Divisional Level	157
Waqar A. Jehangir, Muhammad Ashfaq and Kashif Majeed Salik	
Use Of Poor Quality Groundwater Through Conjunctive Water Management	167
Mushtaq Ahmad Gil, Bashir Ahmad Solehria, Nisar H. Bukhari and Maqsood Ahmad	
Technical Constraints to Deep Groundwater Pumping for Conjunctive Water Management in the Coleambally Irrigation Area, Australia	175
Evan Christen and Shahbaz Khan	
Improving Institutional Arrangements for Conjunctive Water Use in Australia: A Case Study of the Shepparton, Coleambally and Burdekin Irrigation Areas.....	187
Evan Christen, Shahbaz Khan and Ilja van Meerveld	
PART V - GROUP DISCUSSIONS	217
Reports of group Discussions	221
PART VI - OPEN DAY & MODEL DEMONSTRATION.....	225
LIST OF PARTICIPANTS	231

Foreword

Increasing demand and decreasing water quality has put enormous pressure on the agriculture sector to use its available water resources more efficiently and to improve the productivity of water. These pressures are a result of the increasing demand for food and ever limited opportunities for the extension of irrigation to other areas due to scarcity of land and water resources and costs of development. Increasing the productivity of water and the sustainability of existing water resources is central to fight poverty, to reduce competition of water and to ensure that there is enough water for nature. Therefore, there is every motivation to designate more capital and efforts for the management of surface and groundwater resources with respect to quantity and quality in view of rapidly diminishing land and water resources.

Groundwater is now the largest source of irrigation (50-60%) in South and Southeast Asia and North China, and its use for cities is also rising rapidly. The extent of groundwater development in South-Asia can be gauged by the fact that in 1960 there were less than 100,000 irrigation pumps. Today it has over 20 million and agricultural use of groundwater has shot up from a fraction of 1 Km³ in 1960 to over 230 Km³/year. The exploitation of useable groundwater provided an opportunity for the farmers of these areas to supplement their irrigation requirements and to cope with the vagaries of the surface supplies. As a result, in major food baskets of Asia, groundwater is the heart of booming local economies, and the mainstay of agriculture, food security and rural livelihoods. But the current rates of groundwater use in most of these regions are unsustainable. Rapidly falling water tables and increasing salt contents in the pumped groundwater attest that more expensive and poor quality groundwater will have to be used for irrigation in future. This impairs the region's capacity to feed its growing population.

Conjunctive water management is a potential solution that ensures environmental sustainability and financial viability of irrigated agriculture. Conjunctive water management is good in theory, but has not worked well in practice. In addition to technical constraints, the means for actually carrying out effective and sustainable conjunctive water management have not been established. In many places, management tools have been developed, such as water resources models, but they are seldom used for many reasons, including lack of needed data. More importantly, combination of institutions and management tools needed to effectively integrate management of surface and groundwater is lacking, particularly in developing countries. Despite this recognition of the problem and the research, no success in solving these problems is reported from South-Asia.

In order to address these issues, a three-year project on 'conjunctive water management for sustainable irrigated agriculture in South-Asia' was initiated in 1999. The main objective of this project was to identify combinations of institutional and technical strategies to manage surface and groundwater resources at a regional scale to promote environmental sustainability and maximize productivity of water. The project was funded by the Australian Center for International Agricultural Research (ACIAR) and was carried out jointly by International Water Management Institute (IWMI) in collaboration with Pakistan Council of Research in Water Resources (PCRWR) and CSIRO Land and Water, Griffith, Australia.

The project was conducted in two major irrigation areas, Rechna Doab in Pakistan and Murrumbidgee Region in Australia. The Rechna Doab, the interfluvial area between the Chanab and Ravi Rivers covering a gross area of 2.9 million ha including 2.3 million ha of cultivated lands, is the most intensively developed irrigated area in Pakistan. The Murrumbidgee Region is over 0.5 million ha and the largest irrigation are in Australia. As in the case of Rechna Doab, irrigated

agriculture in the Murrumbidgee Region is also facing two major challenges, mainly, limited surface water supplies and land degradation due to salinity and waterlogging. Nearly 165,000 ha in Murrumbidgee irrigation area and 190,000 ha in the Rechna Doab now have water tables within 1.5 – 2.0 m. Due to capillary upflow, salt move with water into profile and are deposited near the soil surface. As a result areas under salinity are increasing continuously. Both areas are within semi-arid environment and have access to surface and groundwater supplies. Due to flat topography, natural drainage is restricted and the environmental consequences of irrigated agriculture – salinity and waterlogging – are the same in these two regions.

To share the findings of this project with different stakeholders, policy makers and water resources managers, a two-day international workshop was organized in Lahore, in April 2002. This book contains the full text of 17 papers presented in this workshop and outputs of working groups, developed during the workshop.

In South-Asia lack of financial resources and infrastructure are the biggest limiting factors in the choice of technologies. Moreover there is a little knowledge about the use of management tools for planning and control of water resources, such as groundwater models and information systems. There are about ten papers focusing on the modeling and technical aspects of conjunctive water management both for Pakistan and Australia. These papers discuss the potential technical strategies appropriate for the local conditions of Rechna Doab and Murrumbidgee regions for the management of surface and groundwater resources in conjunction, with the objective of increasing the sustainable productivity of the limited land and water resources.

Sustainability of irrigated agriculture through conjunctive water management also demands the existence of effective institutional arrangements and long-term on-farm financial and economic benefits for the farmers to ensure that conjunctive water management leads to increased farm incomes and alleviate poverty. There has been a great deal of discussion on conjunctive water management in South-Asia. However, most prior work has focused on the identification of either economic or institutional issues but not both. In many places around the world, the success in the effective conjunctive water management has been reached through combinations of economical, institutional and management tools. About 4 papers in this book, addresses the economical and institutional aspects of conjunctive water management. These papers describe specific experiences of Australia where some degree of success has been reported in the Murray-Darling Basin.

The workshop was attended by about 80 scientists and water resources engineers, coming from major national institutes involved in the management of surface and groundwater resources. Experts from CSIRO, Australia and IWMI-Colombo made special presentations to share their experiences on different aspects of conjunctive water management. On the second day of the workshop technical models and management tools developed during this project were demonstrated to the participants and a full session of on-hand training of these tools was arranged for the water resources managers of various national organizations. Taking the advantage of the presence of a large number of water resources experts three working groups were formulated to discuss a range of widely felt conjunctive water management issues and to prepare guidelines and recommendations for farmers, policy makers and managers for sustainable management of surface and groundwater resources. The reports of these working groups are assembled in the latter part of the book.

Dr. Asad Sarwar Qureshi
Acting Regional Director

Part I

Inaugural Session



Chief Guest, Dr. Buddruddin Somroo, Chairman Pakistan Agricultural Research Council (PARC) addressing in the Inaugural Session of the workshop.

Welcome Address

Dr. Asad Sarwar Qureshi
Acting Director
IWMI Regional Office for
Pakistan, Central Asia & Middle East

Honorable Chief Guest Dr. Badruddin Soomro, Chairman PARC; Dr. Hammond Murray-Rust, Principal Researcher and Theme Leader for integrated water resources management; Dr. Evan Christen, Senior Scientist, CSIRO; Distinguished Guests, Ladies and Gentlemen.

It is a matter of great pleasure for me to welcome you all to this highly significant and important workshop on "Conjunctive Water Management for Sustainable Irrigated Agriculture in South Asia". I am grateful to you, Sir, for sparing your valuable time, despite your heavy official engagements, to inaugurate this workshop. Your presence amongst us is a source of great encouragement and demonstrates the importance, which the present government attaches to the solution of problems of waterlogging, soil salinity and water management. Your valuable advice and guidance would certainly provide food for thought on how to deal with the problems of surface and groundwater management, which are being faced by Pakistan and spreading the world over, eating away the fertility and productivity of our lands. I extend my warm welcome to the distinguished engineers, scientists and other guests who have graced this occasion by their presence.

Sir, irrigated agriculture produces about 40 percent of the agricultural outputs and 60 percent of the world's grain production. To meet the increasing demand for food, irrigated agriculture will have to keep pace, and therefore, expand by 20 to 30 percent in area in the next 25 years. However, it is perceived that due to decreased investments in irrigation sector combined with environmental and ecological threats, the expansion in irrigated area will be limited to the 5 to 10 percent only. This strong reduction in irrigation expansion will lead to serious food shortages and rising food prices. Pakistan is also one of the countries that could face severe food and water crises in the 21st century. Water availability per capita will reduce to less than 600 cubic meters per capita in year 2025. As opportunities for development of new water resources diminish and costs rise, increasing the productivity of existing water resources becomes a more attractive alternative. Therefore, there is every motivation to designate more capital efforts to increase the productivity of present surface and groundwater resources and the sustainability of our lands and environment.

Due to the inadequacy, variability and unreliability of the surface irrigation supplies, the farmers have turned more and more to the use of groundwater without a full awareness of the hazard represented by groundwater quality. The massive development of groundwater from the Indus Basin aquifer started about thirty years ago. At present, total groundwater contribution is estimated as approximately 30 to 40 percent of the total irrigation water available at the farm gate. Although recent IWMI studies in Pakistan have shown that the share of groundwater in agriculture is much more than these estimates and is constantly increasing.

The exploitation of useable groundwater has provided an opportunity for the farmers of these areas to supplement their irrigation supplies and to cope with the vagaries of the surface supplies. However, the present uncontrolled and unregulated use of groundwater is replete with serious consequences as it is depleting the fresh groundwater. This is leading to excessive lowering of groundwater and intrusion of saline groundwater into fresh groundwater aquifer. This is not only deteriorating the quality of groundwater but also increasing the pumping costs. This means more expensive and poor quality groundwater will have to be used for irrigation in future.

Sir, the problems of the Indus Basin are very complex and a straightforward solution seems impossible. An integrated water management approach could be useful to manage available surface and subsurface water resources with respect to quality and quantity in view of increasing demands, limited resources, rising groundwater tables and soil salinization.

That is all this workshop is about. In this project, IWMI has developed tools and strategies for the sustainable conjunctive water management in the Rechna Doab area. The study is carried out with the technical and financial support of the Australian Centre for International Agricultural Research (ACIAR), Australia. The scientists from Australia are also here to share their knowledge and research findings with their Pakistani counterparts.

In the end, once again I thank you for your kind presence in the Workshop. I hope you would be kind enough to overlook any shortcomings in arrangements made for the workshop. I am confident that the present workshop would prove a milestone for education and training of the farmers, policy makers and scientists, and they would take steps to share responsibilities for the management of surface and groundwater resources with regard to increasing crop production without compromising on environmental degradation. Once again, I welcome distinguished participants, engineers, scientists and hope that your stay with us here will be useful and enjoyable.

Thank you.

IWMI's Global Research Themes

Dr. Hammond Murray-Rust

Theme Leader for Integrated Water Resources Management for Agriculture
IWMI-HQ, Colombo

The International Water Management Institute (IWMI) was initially established in 1984 as the International Irrigation Management Institute (IIMI). It is one of the 16 international agricultural research centers under the umbrella of the Consultative Group on International Agricultural Research (CGIAR). The CGIAR centers are divided into two groups: those that deal with specific crops or cropping patterns, such as International Rice Research Institute in the Philippines and the International Wheat and Maize Research Center in Mexico, and natural resource centers that focus on management of water, aquatic resources, forests, policy and agricultural training. IWMI's mandate has been the management of water resources for agriculture.

The change in name from IIMI to IWMI in 1995 was the result of an increasing recognition that we cannot solve all of our water related agricultural problems by looking solely at irrigation management. In many countries we have experienced a changing balance between people and water that has led to growing concerns about water scarcity in the years to come. In Pakistan, for example, water was not a scarce resource at the time of independence: some 30 million people shared approximately 130 million acre-feet of water. Now the same volume of water is shared by 130 million people, meaning roughly each person has one acre-foot of water each year. To use more modern terminology, this comes out to be roughly 1250 cubic meters per person per year, which is close to the threshold value for water scarcity. Pakistan's population is projected to rise to over 300 million people, so that each person will have less than 500 cubic meters per person per year, way below the amount needed to be self-sufficient in food grains. Under conditions of impending water scarcity several things combine that help IWMI shape its research. During the past year we have revised our strategy to focus on five main issues that we feel will help water short countries like Pakistan address these challenges into the first quarter of this century.

The first research area is integrated water management for agriculture, an evolution from the research program of the original IIMI. We recognize that agriculture draws upon all sorts of water resources, including canals, groundwater, rainfall and drainage, and we also recognize that there is intense and growing competition between different sectors, all of which want to have access to more, and better quality, water. Within this research area the main interest is in increasing the productivity of water. While crop-based research focuses on output per unit of land, yield per hectare, IWMI is concerned with maximizing the value of water. This may be yield per cubic meter but because most irrigation systems actually have multiple uses for water it is useful to express water productivity in value per cubic meter.

A second part of this research program looks at using models to examine what the interrelationships are between different parts of the hydrologic system. Water scarcity means that a change in any one use of water automatically affects all other users. We still need to examine what these interactions are because some of them are complex and unexpected. For example, the traditional concept of "losses" in an irrigation system does not hold true in most river basins because the "losses" either end up as groundwater, which is now widely used throughout the world, or as drainage flows that are used further downstream. In the Indus Basin, for example, we use up all the water that comes to the rim stations because of use of groundwater and drainage water, a marked contrast to the image of wasteful irrigation practices that need to be avoided. Of course we continue to undertake research on proper operation of irrigation system operation and maintenance that tries to make sure water is delivered where it is needed when it is needed because this leads to higher confidence by water users, who in turn make better use of more reliable and timely water supplies.

The second IWMI research area is entitled small-scale water and land management systems. Increasing population pressure means increasing pressure on both water and soil resources. If these resources are degraded, either through deteriorating water quality or reduced soil fertility and soil structure, then production will inevitably decline. Every extra gram of salt in either soil or water reduces the productivity of those resources. We therefore look for improved management practices to be undertaken at farm and community level that can help lead to more sustainable production systems. These can be within large-scale irrigation and in peripheral areas, looking at cost-effective ways of conserving resources into the future. We have seen a decline in both water quality and soil conditions in Pakistan over the past two or three decades, and it is important to ensure that this decline be checked and wherever possible, be reversed. We also focus on the refinement and development of small water harvesting systems that can be used to supplement more traditional sources of water, again either in or outside large-scale irrigation systems.

The third research theme looks specifically at sustainable groundwater management. Part of the research covers technical issues related to development and adoption of cost-effective ways of accessing groundwater, such as manually operated pumps and other more sophisticated technologies that aim primarily at poor and disadvantaged groups who cannot afford more expensive pumps and wells. Another part of the research looks at the organizational and regulatory issues that are required to ensure proper groundwater rights and protection of aquifers from irreversible overpumping. The third focus is on the relationship between pumping and energy expenditure. Throughout Pakistan and India, pumping of water consumes a large percentage of total energy produced, and any effort to reduce energy requirements will have a direct impact of government expenditures. Because groundwater pumping now plays a significant role in agricultural production in Pakistan, a marked contrast to the days when pumping was almost exclusively focused on vertical drainage, this is a crucial research area for our staff in Pakistan.

Fourthly, IWMI undertakes research in the area of water resources institutions and policies. The past 30 years have seen huge changes in the way in which government and donors manage and finance water-related projects. These include such familiar things as institutional reform packages, changed attitudes to cost-recovery from water users, greater participation of water users in water resources operation and management, new legislation about water rights and water quality, new regulatory frameworks, and so forth. Pakistan is no stranger to these changes.

We can confidently predict that change will continue. We do not always know what these changes will be, and we do not know what their impacts could be. So research looks at the whole process of

changes in management institutions and policies towards the water sector. In some places IWMI also looks at these issues in a transnational context because water knows no political boundaries.

Finally, but by no means least, IWMI undertakes research that looks at the interaction between water, health and environment. Water scarcity is almost always first recognized when there are major environmental impacts: rivers dry up, ecosystems are damaged, biodiversity is reduced, and so forth. These are familiar to all of us and yet it is only within the past ten years that these have really started to be recognized in most countries. Certainly when IIMI started in Pakistan these were not the issues that were under discussion. To date much of the arguments over environmental issues are emotional, with few hard data available to tell us how much water we really need to maintain a healthy environment and keep river and drainage water at standards that are acceptable to us.

Water is a major factor in our health. Insufficient water means we have lower levels of hygiene, more disease, degraded water quality, increased diarrhea epidemics, and greater infant mortality. Too much stagnant water leads to vectors that transmit malaria, encephalitis, river blindness, and so forth. IWMI works on the relationship between water management and health. A major focus is on addressing problems associated with use of untreated domestic and industrial wastewater for irrigation, and tries to find ways to reduce risks to irrigators and consumers alike. To accomplish these global research programs IWMI has established regional offices in Sri Lanka, alongside our headquarters, in Pakistan, in South Africa to cover all of Africa, in Bangkok to serve Southeast Asia, in Hyderabad in India, and a subregional office in Tashkent for the Central Asian Republics. Next year we intend to open a regional office in China.

Finally, we recognize the need for increased partnership with national programs and agencies. Within the CGIAR system we have commenced a program called Comprehensive Assessment that links research by groupings of CGIAR centers and national partners. At a wider scale we are about to commence on a Challenge Program that links partners across the worlds. This is done in part through the Global Water Partnership and its affiliated national Water Partnerships such as the one in Pakistan, and in part through the Dialogue for Food, Water and Environment, which is hosted by IWMI in Sri Lanka. The Dialogue is the forum by which national partners express their priorities to the world community, and forms the basis for new research and program initiatives.

Finally, IWMI would like to express its deep gratitude to the Government of Pakistan for its support for our program here in Pakistan. When I helped establish the office and the program here in Lahore in 1986 we had no idea how it would end up. All we hoped for was that there would be a productive and mutually beneficial relationship with agencies, institutions and people involved in improving water management in the country. Looking back over these last 16 years I see many ways in which our initially modest expectations have developed. While this could not have been done without our own committed and dedicated staff, it has also required the full support and commitment from many government departments and agencies. The Pakistan Agricultural Research Council has been our official sponsor since the beginning, but the support has been much wider than this and it is impossible to name every group that has helped us and worked with us during this period.

The challenges that face us in the future require even greater effort and greater partnership, and on behalf of IWMI I would like to thank all those who have made the past 16 years a rich and productive collaboration, and look forward with high hopes to continued collaboration into the future.

ACIAR Research Priorities and CSIRO Land and Water Irrigation Research

Dr. Evan Christen

Irrigation and Drainage Engineer (Research), CSIRO, Land and Water, Griffith, NSW, Australia

Assalaam o Alaykum - Good morning – Mr. Chairman, colleagues, ladies and gentlemen. It gives me great pleasure to be here representing CSIRO at this International Workshop arranged by IWMI. The subject as we have heard is conjunctive water management. Water management is one of the most important issues facing many countries around the world, including Australia.

I recently heard the phrase “Water is power”. This is very true, it has the power to bring great benefits – initially to ensure food security by irrigation, and furthermore, to generate wealth from cash crops. This has occurred where I come from in Australia; by the power of irrigation the land is able to economically support 1000 times more people than prior to irrigation. Obviously this truth is demonstrated even better in Pakistan.

However, water also has the potential to bring great misery primarily when the water supply is reduced in either volume or quality. This is one of the key issues that we will discuss in this workshop. Water can also bring misfortune when it is used unwisely, causing waterlogging and salinisation, which results in economic pain for those affected. It is for these reasons that Australia is investing heavily in water research. Water is Power, and as with any source of power we must ensure it is used wisely.

I have been asked to give a brief overview of the activities of ACIAR, the Australian Centre for International Agricultural Research, who have funded the joint IWMI CSIRO project on conjunctive water management.

On behalf of Ian Willett, the ACIAR program leader for Land and Water Resources, I will briefly describe the ACIAR program for you. ACIAR is funded by the Australian Federal government as part of its overseas assistance program. Its aim is to develop collaborative research between Australian institutions and research institutions in developing countries.

ACIAR has nine research programmes including:

- Animal and crop sciences
- Land and Water Resources
- Post Harvest Technology
- Economics and Policy
- Fisheries and Forestry.

The goal of the Land and Water Resources programme is "to contribute to food security and wealth by enhancing long term productivity, management and conservation of land and water resources in developing countries and Australia". In this there are four themes:

1. Land and Cropping systems
2. Soil management
3. Water management
4. Agriculture and environmental quality

Priority setting with each partner country is undertaken by seeking matches between partner country and Australian research priorities. For Pakistan, this was undertaken in 1995 for the Land and Water Resources programme. Nearly all of these priorities are directed at problems of salinisation of irrigated regions. For example:

- development and use of salt tolerant crops,
- management and reuse of saline drainage water, &
- aquaculture.

A full list of priorities can be found at the ACIAR website.

Finally I would like to pass on what Ian Willett sees as the biggest challenge to the Land and Water Resources programme, that is, although it is recognized that land and water resources research has great potential benefits it has been difficult to translate them into tangible (real) benefits to ACIAR's target communities. To compete against demands from other areas of agricultural research we must produce new ideas that will have definite community impacts"

Now a few words regarding my organization, CSIRO. This is the Commonwealth Scientific and Industrial Research Organisation, Australia's premier research institution. It employs more than 4000 people across all spheres of science – from Agriculture, to Human health to Nanotechnology.

In my division, CSIRO Land and Water, we have a large investment in irrigation research. This is co-ordinated under the new banner of "Irrigated Catchment Systems". This group is based in Griffith, NSW with nodes spread across the country. As the name implies we are interested in irrigation (& drainage) at paddock, farm, catchment and even basin scales.

Our group has internationally recognized expertise in undertaking:

- modeling at all scales;
- linking economic and bio-physical issues;
- drainage design and management, and
- safe use of urban wastewater for irrigation.

In these endeavours we hope to have continued collaboration with our colleagues in Pakistan and rise to the ACIAR challenge 'to undertake research that leads to real change on the ground'.

I hope that we can manage to do this for the future. Thank you very much.

Inaugural Address by the Chief Guest

Dr. Badruddin Soomro
Chairman, Pakistan Agricultural Research Council

In the name of Allah, the Beneficent, the Merciful, Dr. Hammond Murray-Rust, Principal Researcher, IWMI, Dr. Asad Sarwar Qureshi, Acting Regional Director, IWMI, Distinguished Delegates and Guests, Ladies and Gentlemen.

It is indeed a matter of immense pleasure for me to inaugurate the International Workshop on "Conjunctive Water Management for Sustainable Irrigated Agriculture in South Asia". The workshop is of great significance to us in view of the importance of irrigation in the agricultural economy of Pakistan. On behalf of the Government of Pakistan, Ministry of Food, Agriculture and Livestock may I extend to you our sincere and good wishes on the occasion of this workshop. I am pleased to welcome the distinguished speakers, who are presenting valuable papers in this workshop.

In the past decade, there has been increasing evidence of problems in the management of surface water and groundwater in the Indus Basin. It is now acknowledged that water delivery targets in most secondary or distributory canals cannot be met during much of the cropping seasons, especially during the period of peak water demand. Consequently, growing numbers of farmers in these canal commands, particularly those located in the tail reaches, must turn to marginal or poor quality groundwater to save their crops, reduce their crop area, or temporarily abandon their farms entirely.

Seemingly, agricultural productivity has leveled off as well, with yield per unit area of all major food and fibre crops continuing to be well below potentials. However, there are some reasons to believe that agricultural productivity per unit of water for many crops remains reasonably high as farmers stretch their irrigation water over a maximum area. The trade-off, as a result has increased salinity risk. Because salinity remains a continuing threat to agricultural productivity and is a condition typically aggravated by low irrigation efficiencies, arresting the decline in canal system performance is an irrigation sector priority. Undoubtedly, some of the present problems of canal system performance are a consequence of deteriorating physical facilities; those conditions, however, are aggravated by inadequate system operation and management.

The major binding limitation in adding to the area of land is the scarcity of good quality water. The existing agriculture land is confronted with many problems too, including waterlogging, salinity, seawater intrusion, and lax management both at the canal and farm level. Other causes frequently cited are an institutional setting where the pressure and interference of influentials must be accommodated, as well as increasing water theft by farmers. Solid wastes and non-saline pollutants in the Indus Basin water are a cause for concern. Seawater intrusion affects substantial portions of the coastal lands.

In Pakistan the system management “blows up” in the distributories. Three social parameters interact: 1) political interference; ii) rent-seeking, which is payment by the beneficiaries for unauthorized services; and iii) farmer anarchy. These social problems distort the water distribution between distributories and among watercourses along each distributory. For instance, wheat yield is 50 percent higher on head reaches as compared to tail enders. The value added per cubic meter of irrigation water is 2-3 times more at the head farms as opposed to tail farms. The only plausible mechanism to overcome inequity is to empower the irrigators so that they can play an effective role in managing the water supplies in their distributories, minors and watercourses.

Poor drainage has been identified as a serious impediment to increased agricultural productivity. Pakistan has been confronted with the menace of waterlogging and salinity since independence. With the construction of each canal, the groundwater recharge in its command due to infiltration from various sources caused a rise of water table. Many of the waterlogging and salinity conditions are created or aggravated by the excessive use of water in irrigation. Poor drainage has also resulted in gradual soil deterioration and subsequent reduction in productivity. If perennial irrigation had been accompanied by a more effective drainage system, agricultural productivity would have been higher.

The need to conserve water and reduce wastage has been put off for so many years that a crisis in water supply will be here before the long process of improvement could be fully implemented. In Pakistan, Indus water is supplied at negligible cost to irrigators. This makes it difficult to adopt irrigation practices that treat water as a precious resource. Water will become increasingly scarce in the future and the Indus riparian provinces will soon face critical water shortages. Conservation of water will be a critical element in the water management strategies of the country. Unfortunately, the nature of water shortages is that they often are not felt until the crisis is severe, making conservation strategies difficult to implement.

The variability of irrigated agriculture in the Indus Basin is threatened by waterlogging and soil salinization. These problems are result of a multitude of factors, including seepage from unlined earthen canals, system, and inadequate provision of surface and subsurface drainage, poor water management practices, insufficient water supplies and use of poor quality groundwater for irrigation. Optimal management of available surface and groundwater resources with respect to quantity and quality in view of rapidly diminishing land and water resources per capita is necessary.

Ladies and gentlemen, I am pleased to note that the workshop will cover a wide range of topics related to the development of strategies for the sustainable management of surface and groundwater resources and institutional arrangements required for the effective implementation of developed strategies and tools. You would, over the next two days, listen to your peers from various organizations that are experts in their respective fields. I am sure you will tell us what the future holds for the Indus Basin sector, which will obviously guide us in chartering the future course of action for better strategies for sustainable agriculture. I have gone through the list of topics on which you are going to dwell in the next couple of days and enlighten yourself with each other's experience. I wish the workshop a success.

Thank you.

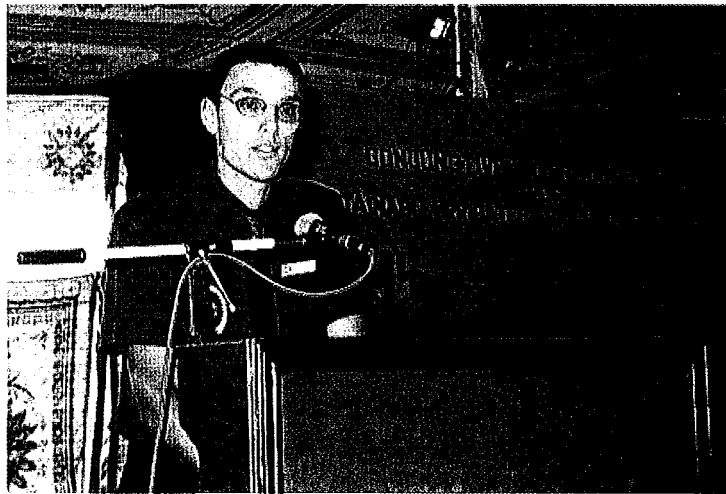

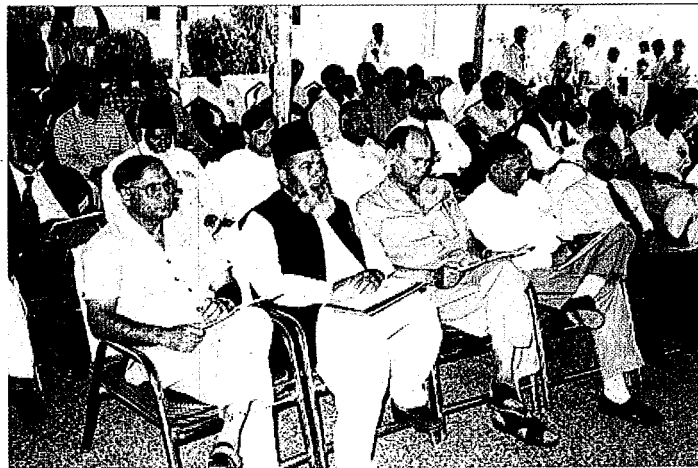
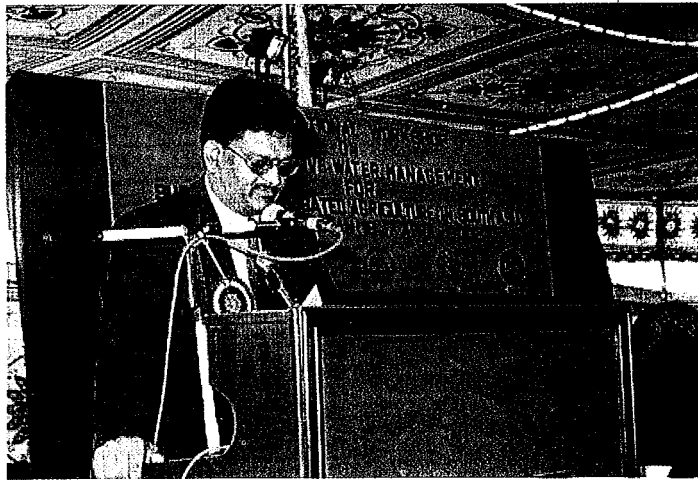
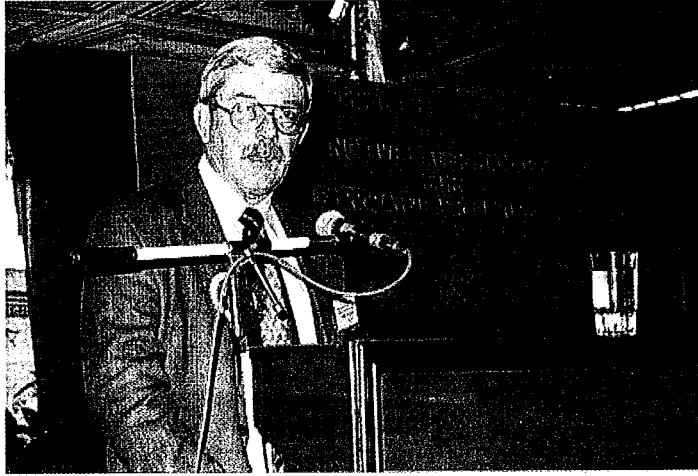

Part II

Modeling Aspects of Conjunctive Water Management



Dr. Buddruddin Somroo, (center), Chairman of the Session
Dr. Hammond Murray-Rust, (right), Keynote Speaker
Dr. Shahid Ahmed, (left), Rapporteur.

Conjunctive Water Use and Conjunctive Water Management

Hammond Murray-Rust¹

INTRODUCTION

Conjunctive use of water from different sources for the purpose of crop production adds a new set of usage and management issues compared to single-source use of water. It requires that a set of decisions be made both at the application level and the water resource level that enable water users to make the best possible use of all available water.

To help clarify a discussion of conjunctive water use, the following division is made in terms of scale and the actors involved:

Conjunctive Use is defined as the actions of an individual, working in isolation to apply water from more than one source to meet crop water requirements, while

Conjunctive Management is the management of water resources either by a group of water users or by some external agency that affects a large group of water users simultaneously.

In many respects it is difficult to control individual use but we can learn and understand a lot from observing how individuals take advantage of multiple water sources to maximize their water productivity or farm level production. Conjunctive management, on the other hand, allows incorporation of water rights and water allocations to be added to the underlying pattern of water use by individuals so that wider ranging goals of equity, production and protection of water resources can be accomplished.

Underlying all of this, however, is the basic condition that a water user wants to increase production or productivity by being able to substitute or supplement the primary source of water. Typically, it is a strategy to minimize the risk of reductions in output due to shortfalls in either water quantity or quality of the primary source when the water user has no capacity to improve the reliability of the primary water source directly.

DIFFERENT TYPES OF CONJUNCTIVE USE

The term "conjunctive use" is an umbrella term that covers a wide range of combinations of water sources, the way in which they are combined, and indeed the purpose of combination. A brief review of these different categories is present below:

¹ Theme Leader, Integrated Water Management for Agriculture, IWMI, Colombo, Sri Lanka

Water Sources for Conjunctive Use

The majority of people will see conjunctive use as a combination of surface water supplies through canals and use of groundwater through pumping. However, this is just one of the several different categories of conjunctive use, and it is useful to remember that conjunctive use can potentially access four different water sources: canal water, groundwater, rainfall, and drainage water. Conjunctive use can cover any combination of two, three or even four of these water sources, and it is, therefore, important to be quite clear as to the nature of water sources involved, particularly when issues of conjunctive management are discussed. Examples are given in Table 1.

Table 1: Examples of Conjunctive Use Systems in South Asia

Primary Source	Secondary Sources	Selected Examples
Canal Water	Groundwater Groundwater + Rainfall	Western Indo-Gangetic Plain (Rabi) Western Indo-Gangetic Plain (Kharif)
Groundwater	Canal Water Drainage + Rainfall	Tail end of many systems Deltas in E. and S. India, Bangladesh
Rainfall	Canal Water Groundwater Drainage	Sri Lanka/S. India (wet season) Eastern Gangetic Plain (Kharif) Bangladesh, E. India
Drainage	Groundwater Canal Water	Deltas in E. and S. India, Bangladesh Deltas in E. and S. India, Bangladesh

In almost every case it is possible to identify the primary water source and the secondary source or sources available to individuals that they can also use. The primary source is not necessarily the single largest use, but the one that determines the basic cropping pattern decided upon by an individual. For example, there are many parts of the Punjab in Pakistan where farmers use more groundwater than canal water, but it appears that the majority of farmers base their cropping decisions on the reliability of canal water supplies.

Combining Different Sources of Water

The way in which water from different sources is combined is also of critical importance to understanding opportunities for conjunctive management. Normally one of two different approaches can be adopted:

- Simultaneous use of water from different sources, so that water from different sources is mixed before application to the crop, and
- Separate use of water from the different sources, relying for a single source of water for each water application.

Simultaneous use is normally found when there are particular technical constraints present. They are normally either because the total flow of water from the primary source is inadequate to allow for proper irrigation and needs to be complemented with water from a secondary source to provide the required discharge, or because either the primary or secondary water source is of poor quality and needs dilution before it can be applied to the crop.

Separate applications are more common when there are significant fluctuations in the primary supply, often rotations in canal irrigation systems or breaks in the rainfall in rain-fed systems. In such cases an individual can manage the secondary source to maintain adequate soil moisture when there are deficiencies in the primary source.

We probably also need to distinguish between conjunctive use as a normal set of practices, where the water user expects to depend on at least two sources of water, and occasional use where there is a primary source on which the water user can depend for the majority of the time but may need access to a secondary source at unpredictable intervals.

Figure 1: Examples of different conjunctive use system

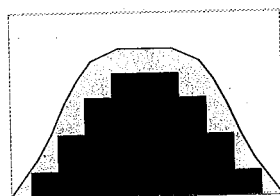

Canal and Groundwater

Canal flow is continuous but less than requirement. Difference made up by continuous pumping of groundwater

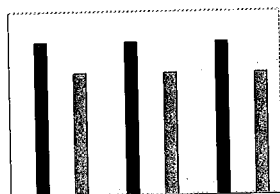

Alternate Canal and Groundwater

Canal flow is on rotation but less than requirement. Difference made up by periodic pumping of groundwater in between surface water flows

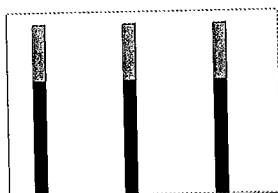

Mixed Canal and Groundwater

Canal flow is on rotation but less than requirement. Difference made up by simultaneous pumping of groundwater when canal water is flowing

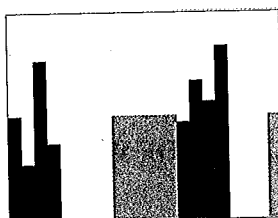

Rainfall and Groundwater

Primary source is rainfall, but during dry periods groundwater is pumped to maintain adequate soil moisture. Pumping stops as soon as rainfall starts again

■ CANAL WATER ■ GROUNDWATER ■ RAINFALL

If these differences in the total range of water sources and the way in which they are combined are not fully understood it becomes very difficult to design and apply a more broadly based conjunctive management strategy. Schematic examples of different types of conjunctive use are shown in Figure 1, indicating the complexity of broader-scale management of water resources in conjunctive use environments.

Threats Arising from Uncontrolled Conjunctive Water Use

In the Pakistan context, we already see a number of consequences of uncoordinated management of water resources that are leading either to sub-optimal use of scarce resources or to threats to the sustainability of land and water resources. In large measure this has resulted from technological

developments that have enabled large numbers of farmers to purchase individual pump sets for exploitation of shallow groundwater.

Table 2 lists some of the more immediate threats that are currently being experienced, and where coordinated management of both surface and groundwater resources is needed. The threats can be seen as either the result of deliberate actions by water users, notably where inequity of access to water has developed or where farmers in fresh groundwater areas are overexploiting the available resources, or they can be indirect threats created by changed physical and hydraulic relationships in soil and groundwater.

Table 2: Threats arising from uncontrolled conjunctive use of surface and groundwater resources in Pakistan

Threat	Main Causes
Groundwater Depletion	Unregulated growth of shallow tubewells in areas of fresh groundwater
Soil Salinization	Excessive recycling of shallow groundwater leading to salt accumulation in upper layers of soil Pumping of poor quality groundwater to compensate for deficiencies in surface water supplies
Deterioration of Groundwater Quality	Leaching of salt accumulation into groundwater Depletion of shallow freshwater overlying saline groundwater Lateral intrusion from saline groundwater
Inequity of Access to Water Resources	Tail end water users forced to pump excessive amounts due to excessive use of surface water resources by head end farmers

Indirect threats are much more difficult to deal with because water users may not immediately perceive the negative impacts of their actions, or may even be unaware of such impacts because the symptoms are experienced by other water users in other locations. They normally have some element of soil or water quality involved which are harder for water users to accurately identify, and which may have a long-term cumulative effect rather than the more dramatic effects of physical water deficits.

THE NEED FOR CONJUNCTIVE MANAGEMENT OF WATER RESOURCES

The diversity of approaches to conjunctive use at field level presents a significant challenge for water resources managers at higher levels in the water management sector. Policy makers in the water sector have a responsibility to ensure that water resources are managed in such a way that there is a high level of effectiveness of resource use while still ensuring broader goals of equity of access to water by as many water users as possible, ensuring the sustainability of the water resource and protecting the environment from undesirable side-effects.

This multi-objective approach does not fit well into an environment where individual water users are only concerned with maximizing their individual objectives of production, profitability and food security. Nevertheless, it is important to try to match both local and national objectives as far as possible.

A significant weakness in the current institutional set up within Pakistan is that no single agency deals with all aspects of conjunctive use, and there are only weak mechanisms for coordination among the diverse range of agencies within the water sector. Yet conjunctive management is as much an institutional issue as a technical challenge.

If we examine the various threats indicated in Table 2, we see that not only are different conjunctive management systems required in different locations, depending on hydrology and geology, but also that in many locations management strategies need to be differentiated between wet and dry seasons.

Single-focus measures are unlikely to be particularly effective in an environment as complex as the ones we actually find. While there are advocates for several single-purpose measures such as groundwater regulation, reallocation of canal supplies to areas of poor quality groundwater, water pricing to restrict demand, or crop zoning to stabilize demand, none of them by themselves address the need to manage at least two different water resources simultaneously.

There is now considerable urgency for integrated conjunctive management in Pakistan. Water is increasingly short, and indeed some believe it is already allocated, the whole of it, between different sectors. Under these conditions each change in water use by one sector will automatically result in a direct impact on all other water users.

In Pakistan some conjunctive management techniques are used, notably response to rainfall involving reductions in canal supplies. By minimizing releases during wet periods maximum use is made of rainfall and some water is conserved for use at a later stage. But opportunities for major savings during wet periods are limited due to the length of canals and the lack of intermediate surface storage systems.

One area for fruitful investigation is to try to use the excessive surface supplies to recharge aquifers in those areas where there is a favorable recharge zone and canal supplies can be diverted when irrigation demand is less. To date this has not been investigated in a systematic manner.

Another opportunity is to make a thorough investigation of the minimum amount of canal water required in fresh groundwater areas, and try to divert the balance to areas where groundwater is of poorer quality. This requires careful modeling to ensure that reductions in good quality surface water supplies will not lead to soil salinization.

But the major step required at present is to develop an integrated database that allows all water resources managers, irrespective of their agency, to see what surface and groundwater conditions are, both in terms of quality and quantity, so that integrated planning of surface and groundwater resources can be made in light of actual conjunctive use patterns at field level.

Only when such an open database exists and is used by managers and planners can an effective conjunctive management strategy be developed. Through its "Benchmark Basin" program, IWMI, in collaboration with several agencies, is developing a prototype database for the Rechna Doab that will demonstrate the utility of shared access to a common database (Figure 2). This can lead to more effective decision-making both by managers and planners that will help lead to sustainable use of fragile water resources.

Figure 2: Front Page of the Integrated Database Under Development by IWMI Pakistan

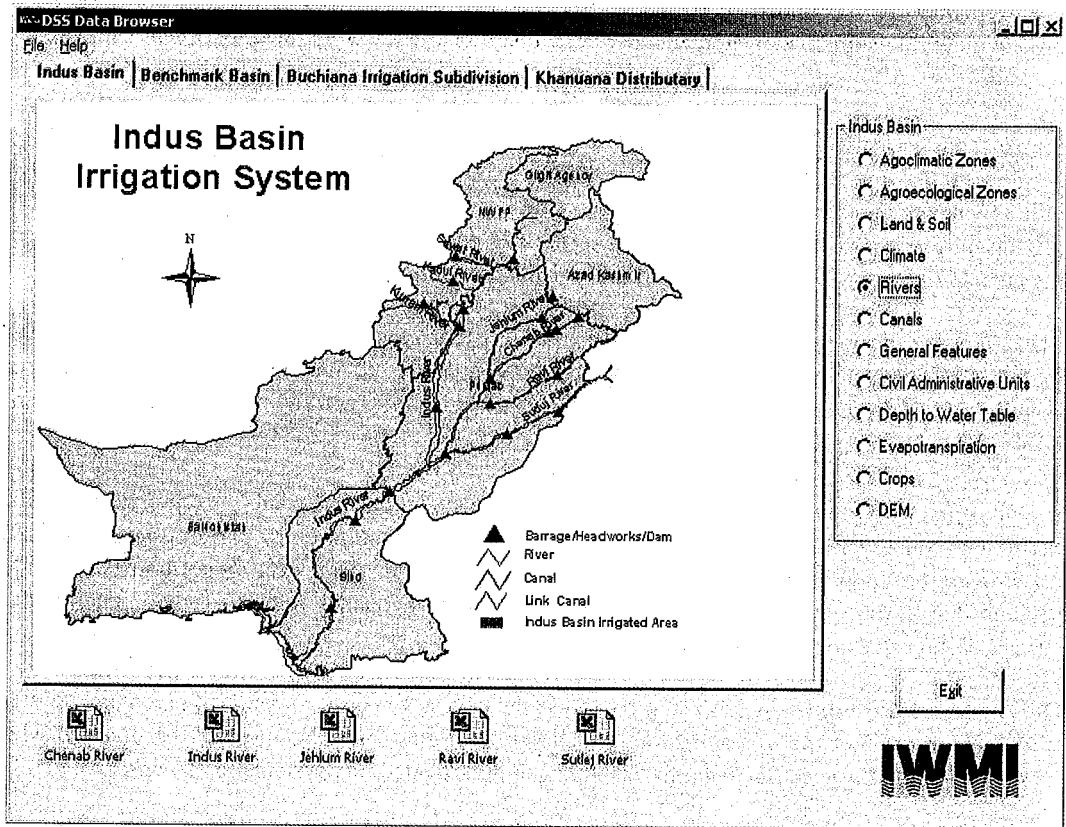

Conjunctive Water Management for Sustainable Irrigated Agriculture in Rechna Doab: An Overview and Progress of Research Work

Waqar A. Jehangir¹

BACKGROUND

The conjunctive water management project aimed to identify combinations of institutions and technical strategies to manage surface and groundwater at regional scale to promote environmental sustainability and maximize agricultural productivity of water ('crop per drop'). Two major semi-arid irrigated areas, Rechna Doab in Pakistan and Murrumbidgee Region in Australia are chosen for this study. Both areas have access to surface and groundwater supplies, but overall water is the limiting factor for agricultural production. Both areas lack in the availability of natural drainage due to flat topography, and the environmental consequences of irrigated agriculture (salinity and waterlogging) are also similar in these two regions. The project was started officially on January 1999 and would end by June 2002. This project is funded by ACIAR, and executed with the technical collaboration of CSIRO, Australia. The local collaborators in Pakistan are Pakistan Council for Research in Water Resource (PCRWR), Soil Salinity Research Institute (SSRI) and Ayub Agricultural Research Institute (AARI).

OBJECTIVES

The primary objectives of the project are to develop and test methods of controlling waterlogging and salinity through effective conjunctive management of surface and groundwater supplies. The components and specific objectives as per approved project are listed below:

PROJECT COMPONENTS AND PROGRESS

A: Identification of combinations of institutional and technical strategies that promote sustainable conjunctive water management at the regional scale:

Specific objectives of this component are to:

1. Identify combinations of technical strategies and institutional arrangements and rules that promote sustainable conjunctive water management in irrigated areas.
2. Identify institutional constraints in Rechna Doab that impede effective conjunctive water management.

Research Output:

Four country reports have already been published.

¹ Senior Agricultural Economist, IWMI Regional Office, Lahore

B: Evaluation of the technical feasibility of providing irrigation water of acceptable quality from multiple sources in a timely manner across an irrigated region and their environmental and economic/financial consequences.

Objectives of this component:

1. Identify technical constraints in Rechna Doab and in Coleambally Irrigation Area (CIA) in the Murrumbidgee Region that impedes effective conjunctive water management.
2. Determine sustainable levels of groundwater and surface water use in Rechna Doab and CIA, Murrumbidgee Region.
3. Determine strategies to induce recharge in parts of Rechna Doab where groundwater levels are falling.
4. Evaluate effective drainage management strategies at the distributary level in Rechna Doab and farm level in the Murrumbidgee Irrigation Area (MIA), Murrumbidgee Region.
5. Identify technical solutions for encouraging effective conjunctive water in Rechna Doab and the Murrumbidgee Region.
6. Assess on-farm financial/economic effects of alternative technical solutions aimed at increasing optimal and sustainable conjunctive use of water in Rechna Doab.

C: Design and transfer of knowledge and technology to stakeholders in the CIA and in Rechna Doab

Objectives:

1. Design and communicate technical and institutional guidelines for policy makers and Area Water Boards within Rechna Doab.
2. Design and communicate technical guidelines for policy makers in the Murrumbidgee Region.

Research Activities

Research activities under component (A1) and (B1) are already finished and the output to that effect has been reported in the 1999 progress report. The description for activities under environmental and financial component (B2-B6) and design and transfer of knowledge to stakeholders (C) are provided against the specific objective.

B2: Determine sustainable levels of groundwater and surface water use in Rechna Doab and Identify technical solutions for encouraging effective conjunctive water in Rechna Doab

In the Rechna Doab, in order to formulate an optimal conjunctive water management system for irrigated agriculture in the area, nodal network water balance approach was used to access the available water resources and estimation of recharge to groundwater aquifer. The various activities, which were completed during the year 2001, were comprised of comprehensive data base development, water balance study, and conjunctive water management modeling study. The objective of the conjunctive water management model for Rechna Doab was to maximize utilization of surface supplies and the extraction from groundwater, which will be environmentally friendly. The constraints considered were: surface water availability, capacity of the surface water distribution system, water rights, groundwater levels, groundwater quality, water demands for ensuring environmentally sustainable conjunctive water management in Rechna Doab.

B3: Artificial/managed recharge basin siting strategy: A GIS based approach and Geophysical investigations

The objective of this activity was to prepare a framework for citing artificial recharge zones in Rechna Doab by evaluating soils, hydrogeology, water, land use and general conditions applying modern techniques of geographical information system. A set of criteria acceptable for sighting a recharge basin was established for transmitting layer and storing layer. The transmitting layer was the unsaturated soil profile in the basin area having conditions for infiltrating and conveying acceptable quality water to the aquifer system. Its evaluation was based on soil texture and salinity. The storing layer was the aquifer system having capability of storing percolated water and recovery by wells. This layer was evaluated on the basis of history of depth to water table, aquifer parameters and groundwater quality. It was proposed that a reach of the storm water drain traversing the potential recharge zone might be developed to fulfill the purpose of reducing, stopping, or even reversing declining levels of groundwater. The secondary information on storing layer was analyzed in terms of history of depth to water table, aquifer parameters and groundwater quality. Five areas were identified in lower Rechna Doab in the vicinity of Chenab and Ravi Rivers; from two to eleven thousand hectares in size have been delineated fulfilling the requirements. The availability of excessive water and conveyance to the delineated site were of prime consideration. A surface drainage network in Rechna Doab constructed to carry storm water runoff and canal escape water was superimposed. Four out of five sites were located close or within the course of a drain system. Two sites traversed by and close to reaches of main drains were proposed for potential development as an artificial recharge area. Geophysical investigation at two locations was carried out by PCRWR. For Geophysical investigations, sixteen and twelve Vertical Electrical Soundings (VES) were established in Kamalia and Mamun Kanjan areas of Rechna Doab respectively. Following conclusions were drawn from the geophysical investigations done at two sites:

- Generally sand formation was found in the area.
- Geophysical investigations support the findings of GIS.
- Depending upon the geophysical conditions of two sites, water spreading and pit techniques can be useful for artificial recharge in the Kamalia area site whereas dug well up to 10m depth can serve the purpose in Mamun Kanjan area.

B4: Evaluate effective drainage management strategies at the distributary level in Rechna Doab and farm level

A subsurface evaporation basin (SEB) trial as a combination of biological, engineering and agronomic measures was established in Rechna Doab under this activity in the year 2000. Monitoring and evaluation activities regarding depth to water table data, groundwater quality, soil salinity, climatic and hydrological data were continued during this year.

The objectives were:

- To apply an innovative approach for drainage and reclamation of land and redress the problem.
- To ensure tree growth and increase discharge from the water table due to transpiration.
- To encourage pre monsoonal plowing of abandoned land to increase infiltration of rainfall and to provide leaching.

ESTABLISHMENT OF SUBSURFACE EVAPORATION BASIN (SEB)

The SEB trial was established to reclaim the abandoned waterlogged and saline soils. The system relies upon groundwater flow into the SEB. Due to the drought conditions from 1998 to 2000, the water table went down about 1m below the bed depth of SEB in June 2001. Dr Shahbaz Khan and

Dr Evan Christen from CSIRO visited the SEB site during the first half of the year 2001. After discussing SEB with the CSIRO experts, following activities were carried out.

- Plantation of rice crop adjacent to SEB (southern and eastern side) to raise the water tables to normal levels. Full amendments were used in growing the rice crop.
- Depth to water table data were analyzed for hydraulic gradients along the north south and east west transects for monthly intervals.
- Water quality parameters were plotted over time for each piezometer. These piezometers then grouped from nearest to farthest from SEB.
- Piezometer levels were plotted against rainfall events.
- Spatial and temporal changes in soil salinity are plotted over time.
- A relief hole of 1.2m diameters and 0.9m deep was dug to penetrate into sandy layer below. This SEB site is a two-layer system. The top 2m layer is clay loam below which there is sand aquifer. Thus the lower layer is more transmissive and has more potential for water to move towards SEB. So to see the movement of water towards SEB, the relief well was dug.
- SEB Modeling exercise by using MODFLOW is completed. Different scenarios are developed to determine conditions under which SEB approach may be applicable.

B5: *Identify technical solutions for encouraging effective conjunctive water in Rechna Doab and the Murrumbidgee Region.*

The discussions were held with stakeholders to finalize the modeling scenarios for conjunctive water management.

B6: *Assess on farm financial/economic effects of alternative technical solutions aimed at increasing optimal and sustainable conjunctive use of water in Rechna Doab.*

The information was collected from the field by using pre-tested questionnaires. The primary data were collected from 544 farms on distribution of soils with in the farm, potential land uses, economic returns from potential land uses, farm land use practices / particular cropping intensity, optimum/ maximum economic return to farmer. The secondary data sources were used for the data on crop evaporative requirements, current irrigation practices, leaching requirements, annual rainfall, leakage to deep aquifer, depth to water table, capillary up flow from shallow water table, salt concentration of irrigation water and ground water, acceptable net recharge, acceptable gain of salt in root zone. The data were processed and analyzed by using the SWAGMAN Farm model developed by CSIRO. This model identified environmentally sustainable levels of irrigated agriculture and has been modified and adapted for 28 sub divisions within the Lower Rechna Doab. The initial results of the model were presented in the workshop during April 16-17, 2002 and the research report will be finalized with the help of Dr. Shahbaz Khan by June 2002.

C1: *Design and communicate technical and institutional guidelines for policy makers and Area Water Boards within Rechna Doab.*

A workshop on Institutional Aspects of Conjunctive Water Management was held on July 6, 2000 in Lahore, Pakistan. All the stakeholders were invited to contribute in the workshop. The researchers from IWMI, PCRWR, University of Punjab Lahore, and other members from Steering Committee/PIDA/NDC/PDC participated in the meeting. The workshop provided important input for the institutional and legal aspects of water management in the Rechna Doab.

Role of Surface and Groundwater in Meeting Crop Water Demand in Intensive Agriculture Systems Using a Nodal Network Approach

M. Kaleem Ullah¹, Shahbaz Khan², Evan Christen³, and H. M. Nafees Ahmad⁴

ABSTRACT

Over the years the cropping intensities and cropping patterns have changed for meeting the increased demand of food and fiber in the Indus Basin of Pakistan. Cumulative effect of rainfall, river irrigation and groundwater resulted in the high cropping intensities in the Basin. In the recent dry years rainfall and river supplies have failed to meet irrigation water requirements in some areas where there had been traditionally no surface water shortage for irrigation. Such conditions of drought in water scarce areas have increased pressure on groundwater, which has variable potential across the Indus Basin in terms of quality and quantity. Farmers are forced to increase their groundwater abstractions to fill the gap between crop demand and surface water supply.

The number of private tubewells has increased more than three-fold in the last 15 years. This increasing trend of tubewell installation in the basin, along with the uncontrolled groundwater abstraction has started showing aquifer stress in certain areas. In some parts, especially along the tail of canal systems, water levels are showing a steady rate of decline and hence - the mining of aquifer storage. Tubewell density is higher in areas having fresh groundwater as compared to saline groundwater zones. Even in fresh groundwater areas, uncontrolled groundwater abstraction may lead to the deterioration of groundwater quality. Under such aquifer stress conditions, there is a need to regulate and manage groundwater in agricultural context.

In this paper the contribution of groundwater in the irrigated agriculture of Rechna Doab, Punjab, Pakistan is explored using a nodal network approach and water balance. In the same paper, crop water demands, rainfall, and surface water are calculated to estimate the groundwater abstraction in different sections of canal commands of Rechna Doab to understand its usage patterns from 1997 to 2000. This work is also aimed at evaluating surface water availability and the assessment of spatial distribution of groundwater abstractions by considering the present crop water demand patterns.

INTRODUCTION

Water is the most vital resource for human existence from its drinking water requirements to the production of food and fiber. Since Pakistan lies in a sub-tropical continental lowland semi-arid region where the rainfall is untimely and not enough to support agriculture. To meet ever increasing

¹ Junior Civil Engineer, International Water Management Institute (IWMI), Lahore, Pakistan

² Senior Research Scientist, CSIRO, Land and Water, Griffith, NSW, Australia

³ Irrigation and Drainage Engineer (Research), CSIRO, Land and Water, Griffith, NSW, Australia

⁴ Research Officer, Pakistan Council of Research in Water Resources (PCRWR)

food and fiber requirements of a massive (>130 million) and growing population (growth rate ~ 3%) Pakistan has to rely on irrigation from surface and groundwater. In many parts of Pakistan the irrigation supplies do not meet the crop needs for better yield. The aggregate shortage of surface water is estimated to be about 40 percent of crop potential consumptive use (Ahmad, 1988).

During the recent dry years the surface water supplies have failed to meet irrigation water requirements in areas where there was traditionally no surface water shortage for irrigation. It has resulted in reduction in crop yields and dependence on import of agricultural commodities to feed masses. Since late 1970's the shortfall in surface water supplies has been fulfilled by groundwater, which has variable potential across the Indus Basin in terms of quality and quantity. Presently, farmers are increasing their groundwater abstraction to fill the gap between demands and supply as the surface water supplies are already fully committed and cannot cope with the crop water demand. Tubewell density is higher in areas that have fresh groundwater, and vice versa. Intensive groundwater pumping in certain areas has started showing stress on the aquifer in some parts especially in tail areas, water levels are already showing decline. Uncontrolled groundwater abstraction may lead to the mining of aquifer and/or deterioration of groundwater quality. As the rate of groundwater use is approaching its potential availability, there is need to define role of surface and groundwater in meeting the crop water demand.

The Rechna '*Doab*' (*land between two rivers*) as shown in Figure 1 is selected for present study. It is the interfluvial sedimentary basin of the Chenab and Ravi rivers which lies between longitude 71' 48' to 75' 20' East and latitude 30' 31' to 32' 51' North. The gross area of Rechna Doab is 2.97 million ha. with a longitudinal extent of 403 km and maximum width of 113 km and comprises of 2.3 million hectares of prime cultivated land. The Rechna Doab is a sub-tropical, continental lowland best described as a semi-arid region. The climate is characterized by large seasonal fluctuation of rainfall and temperature. Average annual precipitation varies from 290mm in Shorkot (extreme south) to 1046mm in Sialkot (Extreme North) within the Doab. The highest rainfall occurs during the monsoon circulations in the month of July and August and accounts for about 60 percent of annual rainfall. It is one of the oldest, agriculturally richest and most intensively populated irrigated areas of Punjab, Pakistan. The area falls in the rice-wheat and sugar cane-wheat agro-climatic zones of the Punjab province, with rice, cotton and forage crops dominating in summer season (*Kharif*), wheat and forage in winter season (*Rabi*). In some parts sugarcane is also cultivated which is an annual crop.

In this paper spatio-temporal trends of surface water shortage and groundwater demand are estimated from 1997 to 2000 on monthly bases. For analysis purpose supply model of Rechna Doab is developed by dividing the area into a series of nodal networks consisting of channel segments, demand nodes and lumped production areas based on connectivity and on surface water flows. Major research contribution is to evaluate surface water availability and provide an assessment of groundwater abstractions by using Canal Water Availability Ratio (CWAR) concept.

Figure 1: Physical Layout of Canal Network in Rechna Doab

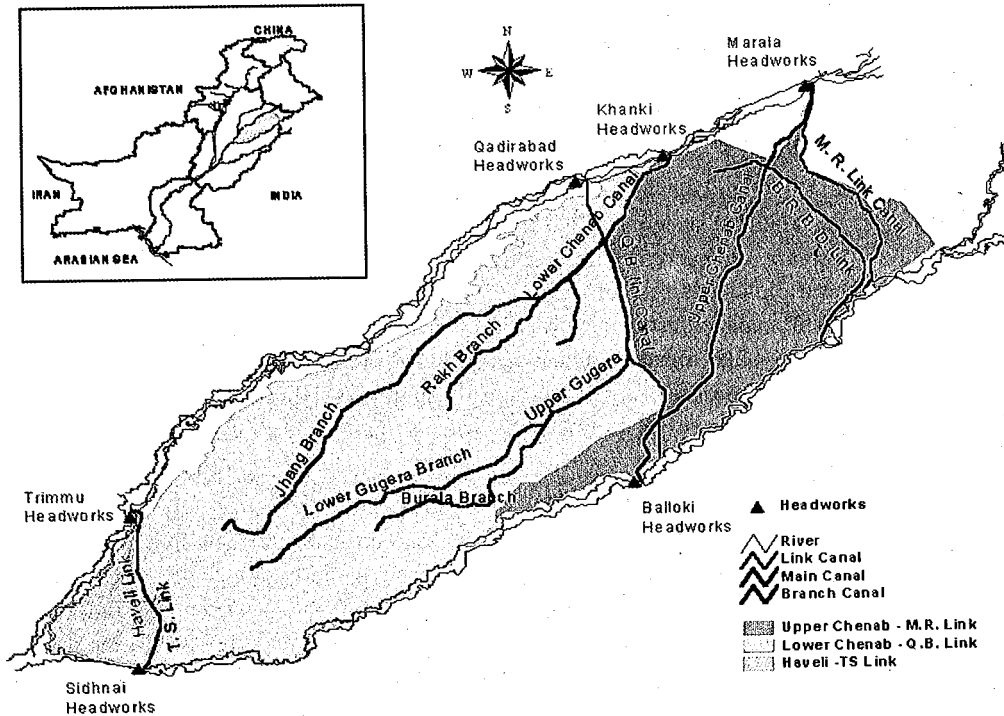

CONCEPTUALIZATION OF NODAL NETWORK APPROACH

In Rechna Doab, the canal irrigation system was introduced in 1892 with the construction of the Lower Chenab Canal (LCC). With the passage of time few other canals were constructed to irrigate the area of Doab. At present the flows of the Chenab and Ravi rivers are regulated at six major headworks (four on the Chenab River and remaining two on the Ravi river). These headworks ensure diversions to the main and link canals. All these head works were constructed in late 19th and early 20th century except Qadirabad headworks, which was constructed after Indus Basin Treaty with India in 1960. Rechna Doab comprises of two main canals and five link canals. The Upper and Lower Chenab Canals are the main canals, off taking at the Marala and Khanki Headworks, respectively. The five link canals are Marala-Ravi (MR), BRBD (Bambanwala-Ravi-Bedian-Depalpur), Qadirabad-Balloki (QB), Trimmu-Sidhnai (TS), and Haveli.

At the time of construction the canal network was designed for supporting low cropping intensities. However, the cropping intensities have been drastically increased (up to 150%), in the last two to three decades, with the rapid development of public and private tubewells. Nevertheless the quality of groundwater is not comparable with canal water. Presently, canal water availability is known and the contribution of groundwater to meet crop water demand is identified by water balance analysis.

For water balance analysis, depending on the direction of flow and connectivity of canals between Chenab and Ravi rivers the system has been divided into three sub-systems or sub nodal networks

(Figure 2). Nodes are the points where flows or command areas are known between different reaches of the channels.

- Upper Chenab and Marala Ravi Link canal (UCC-MR)
- Lower Chenab and QB Link canal (LCC-QB)
- Haveli and Trimu Sidhnai Link canal (H-TS)

Nodal Network Model of Upper Chenab and Marala Ravi Link Canal (UCC-MR)

Nodal network model of Upper Chenab and Marala Ravi Link canal consists of three canal systems as shown in Figure 2a. The first system is MR Link canal, an unlined channel of 101 km length and flows into Ravi upstream of Lahore. The second system is Upper Chenab canal, which was constructed under the triple canals project in Punjab, and by 1915, was completed. Upper Chenab canal also serves as link canal transferring water from Chenab to Ravi and is discharging above Balloki in Ravi River. At 40269 m from its head it is divided in three channels i.e. Nokhar branch, BRBD and Upper Chenab Main Line Lower. The third system is BRBD canal off taking from UCC and its length in Rechna Doab is 86128 m; this portion also irrigates some area in Rechna Doab.

Nodal Network Model of Lower Chenab and QB Link Canal (LCC-QB)

This is the biggest nodal network model in the Rechna Doab consisting of one link canal and one main canal from which number of branches are off taking as shown in Figure 2b. The LCC takes off from the Chenab River at the Khanki Headworks. It covers entire area between QB and TS Link Canals, some area above the QB Link Canal along the Chenab River and area below the TS Link Canal. The Lower Chenab canal at Sagar head regulator is divided into two branches: Main Line Lower and Gogera branch. The Main Line Lower is further divided into three branches Jhang branch, Mian Ali and Rakh branch. Similarly the Gogera Branch is divided into two branches: Burala and Lower Gogera. The QB Link Canal off-takes from the Qadirabad Headworks on the Chenab River. It was constructed and opened in the mid-1960s to transmit water to the Ravi River at Balloki Headworks. After 24 km from its head, LCC feeder takes off to add water into LCC-Jhang Branch.

Nodal Network Model of Haveli and Trimu Sidhnai Link Canal (H-TS)

This nodal network model consists of two canals (Haveli and TS Link) and one feeder (Koranga) canal. Haveli canal was formally opened in 1939 (Figure.2c). This canal off takes from Trimu Headworks on the Chenab River below confluence of the Chenab and Jhelum. The TS Link was the first canal under the Phase-1 of the Indus Basin settlement Plan and was aligned parallel to the Haveli canal. Both the canals were relocated and had a combine regulator. The feeder is off taking from LBDC system and entering in the Rechna Doab through an aqueduct at Sidhnai Barrage.

Figure 2a: Nodal Network Model of UCC-MR

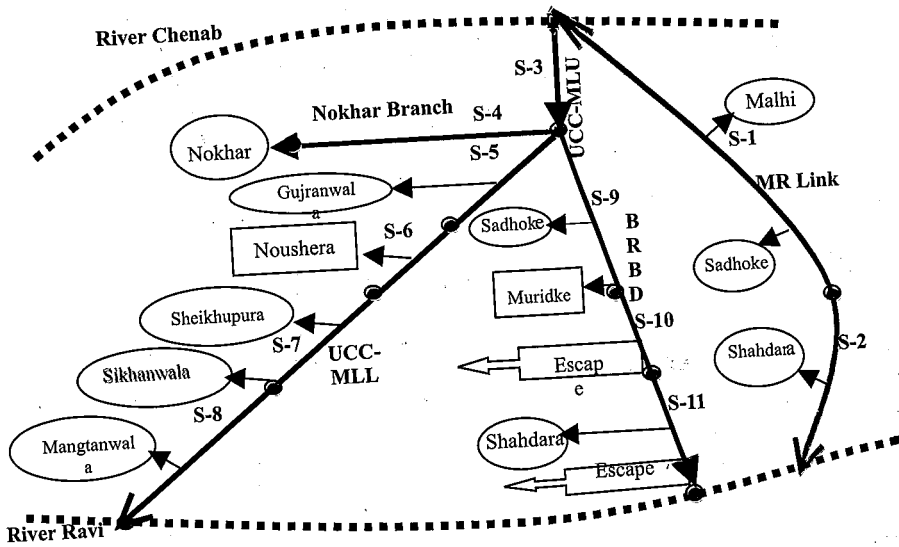

Figure 2b: Nodal Network Model of LCC-QB

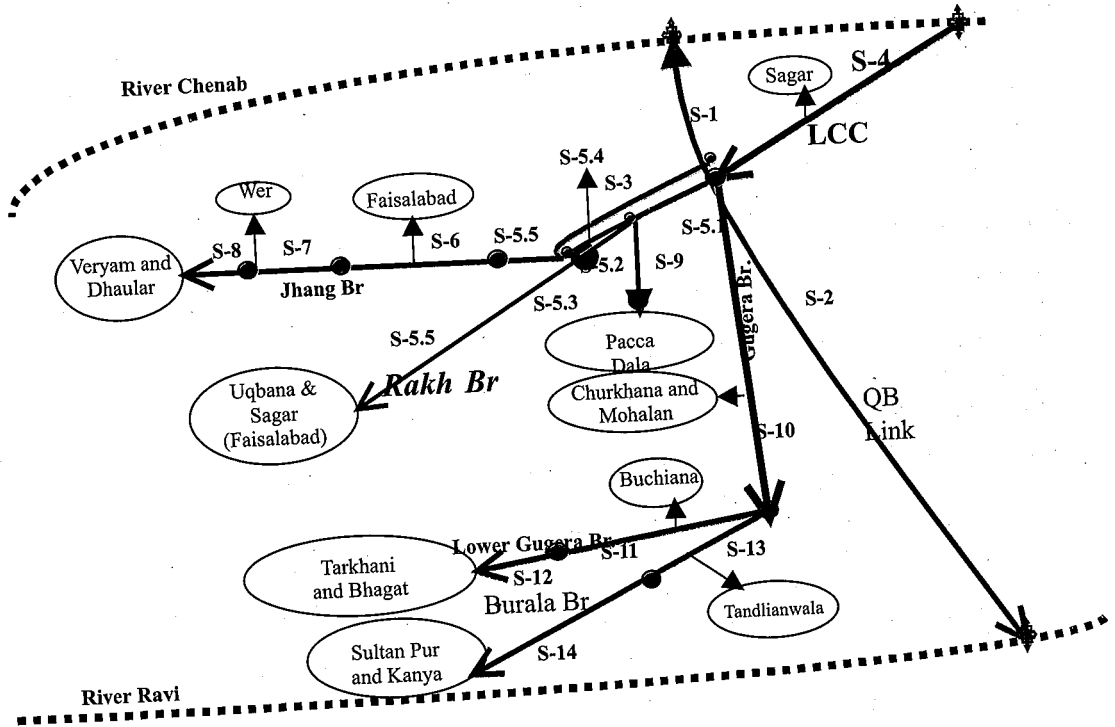
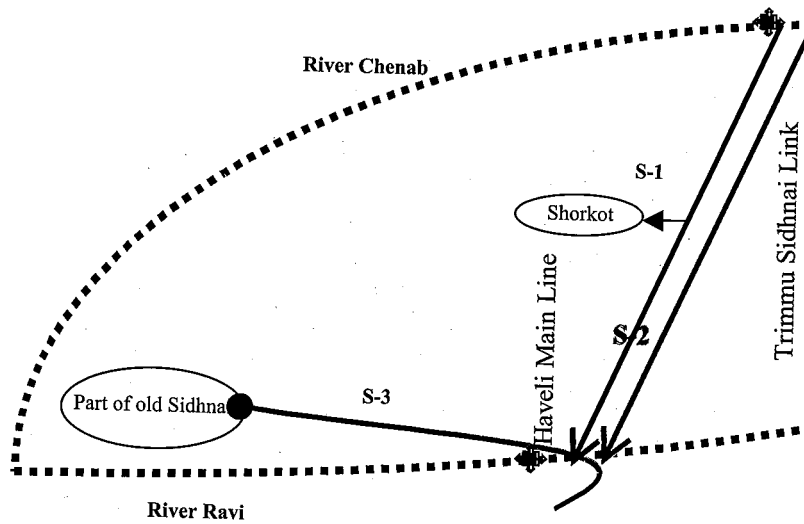

Figure 2c: Nodal Network Model of H-TS



METHODOLOGY FOR COMPUTATION OF WATER BALANCE ALONG THE NODAL NETWORKS

The following methodology was used for developing spreadsheet model of the monthly water balance for each production area of all three individual nodal network models:

- Crop water demand of each production area
- Surface water availability to the crops
- Canal water availability ratio
- Estimation of groundwater demand

Crop water demand of each production area

Many factors influence water demand by plants and it may differ with locality and fluctuate from year to year. Based on these factors the process of crop water requirement is divided into 5 sections:

1) Computation of Reference Evapotranspiration 2) Selection of Crop Coefficients 3) Potential water demand of different crops 4) Net water demand of different crops 5) Estimation of crop water demand of production area.

- Reference evapotranspiration was computed by FAO CROPWAT model based on Penman-Monteith equation. The key climatic parameters used for the estimation of reference evapotranspiration are temperature, humidity, wind speed and sunshine hours. Data on all climatic parameters were available for climatic stations within the Rechna Doab on long-term basis (20 to 30 years from 1960-1995). The data for different climatic factors was pre-processed to meet the model requirement.
- The Rechna Doab lies in rice wheat and sugarcane wheat agro-climatic zone. These agro-climatic zones exhibit different cropping patterns and crop-periods within the zone. For the selection of Kc value, Rechna Doab is divided into five different zones and for each zone the periods of planting and harvesting, crop duration and crop growth stages for different groups of areas were determined on the basis of primary and secondary information (WAPDA 1979, IIMI 1996, GOP 1997, PARC 1982, PPSGDP 1998, FAO, 1977 and FAO

1998) about cropping practices in the Doab. For most of the crops, the planting and harvesting period is extended over a couple of weeks.

- Potential water demand of different crops was computed by multiplying reference evapotranspiration of that production area with crop co-efficient selected for different crops in respective production area.
- The net water demand for a given crop is the depth of irrigation water, exclusive of effective rainfall from crop water requirement. It is the quantity of irrigation water required to keep the soil moisture at readily available water (RAW) level in the crop root zone. To compute the net water demand of different crops, the effective precipitation was estimated by using relationship developed by U.S. Bureau of Reclamation. The effective precipitation for climatic stations within and close to the Rechna Doab was estimated and delineated for each production area associated with each segment of nodal network model. The net demand of water for different crops was water determined by subtracting effective rainfall from the water demand.
- Water demand of production areas was estimated by multiplying net crop demand of different crops with the area under each of these crops and summed for each production area of nodal network models.

Canal Water Availability for Crops

Canal water available to crops for irrigation of production areas of various segments of nodal network model was estimated by subtracting losses (seepage and evaporation) from available flows. These flows were measured at different locations in the irrigation network. For the estimation of canal water available to crops losses were considered at main canal or branch canal, distributary, watercourse and field level. The description of each type of losses is discussed below:

Main Canal or Branch Canal Losses: For main canal, seepage and evaporation losses are calculated separately by method given below:

- Seepage Losses: Patten et al. 1963 attempted to statistically correlate canal seepage with the canal discharge. Similar to Patten's original relationships the following relationship has been used (PPSGDPC, 1998):
$$S = 0.052Q^{0.658}$$

Where s is seepage loss in cfs/mile and Q is canal discharge in cusecs. For present study, main and branch canal seepage losses are estimated by this method.

- Free Surface Evaporation Losses: For different segments of nodal network models the evaporation value of nearby station is used. These losses were calculated by multiplying free surface evaporation with area of channel.

Distributary losses: Distributary losses were assumed 6 percent by considering the work of Khunger (1946) in Punjab (Ahmad, 88). Percolation and evaporation losses were considered 95 percent and 5 percent respectively.

Watercourse losses: These losses were calculated by using Maasland (1968) approach (Ahmad, 88), which was developed during recent years; he worked out 10% losses employing different assumptions, half of these losses consist of percolation and the rest are evaporation.

Field Losses: For present study Maasland assumption of 20 percent loss of water delivered to the field is used. 25% of which is lost as evaporation and remaining is recharged to groundwater.

Canal Water Availability Ratio (CWAR)

This is simply the ratio of available canal water for crops to meet crop water demand of production area. If this ratio is less than 1 then there will be shortage of canal water supply and groundwater contribution is required to meet crop demand. Otherwise, if it is greater than 1 then surface water supply is more than crop water demand resulted in over irrigation of that production area. To visualize the role of surface water in meeting crop demand, monthly canal water availability ratios (CWAR) are determined for each of the production area using Equation-1.

$$CWAR = (VCH - VL) / VNCWR \quad (1)$$

Where

$$VL = VMCL - VDL - VWCL - VFL \quad (2)$$

$$VNCWR = \Sigma(ET_o \times K_c) - \text{Effective Rainfall} \quad (3)$$

VCH = Volume Water at Head of Canal

VL = Volume all Water Losses

VMCL = Main canal Losses (seepage and evaporation)

VDL = Distributary Losses (seepage and evaporation)

VWCL = Water Course Losses (seepage and evaporation)

VFL = Field Losses (seepage and evaporation)

VNCWR = Volume of net crop water demand for production area

Estimation of Groundwater Demand

Canal water supplies and groundwater are the only resources to fulfill net crop demand in each production area. On the bases of estimation of monthly canal water supplies available to crops and net crop water demand, groundwater contribution can be calculated by finding the gap between demand and supply. The simple equation 4 was established for the estimation of groundwater for each production area, which is given below:

$$VRGW = VNCWR - (VCH - VL) \quad (4)$$

Where

VGW = Volume of Required Groundwater Contribution

RESULTS AND DISCUSSIONS

The water balance analysis was carried out for the all production areas of three nodal network models of Rechna Doab. This analysis will help in understanding surface and groundwater interaction along the supply network. In this paper, to illustrate the usefulness of this technique, results of three production areas are discussed from each nodal network model. The general features of these production areas are given in Table 1:

Table 1: Salient Features of Selected Production Areas

Name of Production Area	Nodal Network Model	Off-taking Segment Number	GCA	CCA	No. of Channels	No. of Outlets
			(Hectares)			
Muridke	UCC-MR	IX	74548	73813	10	314
Veryam and Dhular	LCC-QB	VIII	206051	160936	51	761
Shorkot	Haveli-TS	II	78805	74936	15	325

The results of different components of water balance analysis of these production areas for period 1997-00 are presented one by one in the following section:

Crop water demand of selected Production Areas

Reference Evapotranspiration

Monthly reference evapotranspiration for the climatic stations within and close to Rechna Doab are computed by using model indicated in previous section. The computed values of reference evapotranspiration for each climatic stations are delineated at different production areas of segments of nodal network models. The temporal variation of ET_0 in selected production areas is shown in the Figure 3.

Figure 3: Variation of Reference Evaporation Over the Year for the Selected Production Areas

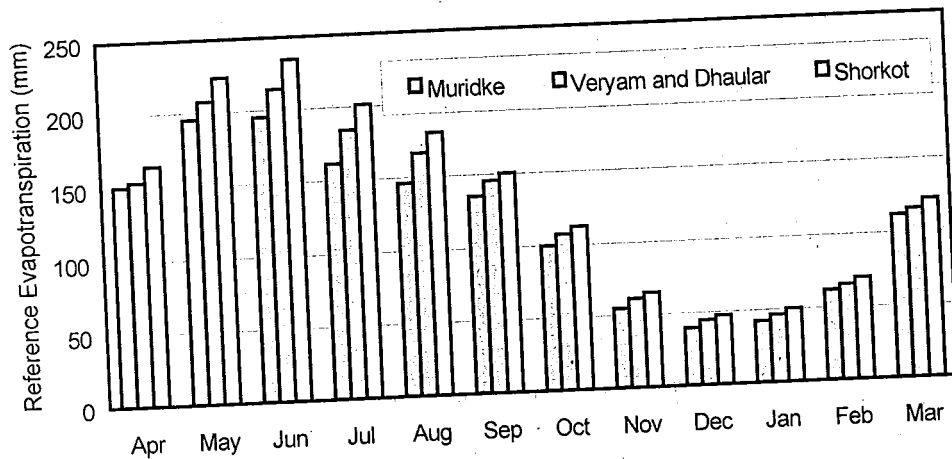

Figure 3 shows that ET_0 increases from north to south- Muridke located in Upper Rechna (extreme North), has minimum ET_0 value of 1396 mm/year whereas Shorkot which is located in Lower Rechna (extreme South) has maximum value of 1622 mm/year. Temporally, minimum and maximum ET_0 values are found in December and June respectively. The main factors influencing this spatio-temporal variation are temperature, humidity, wind speed and altitude.

Selection of Crop Coefficient

The reference evapotranspiration generally increases from North to South in Rechna Doab. This variation of reference evapotranspiration along with different landforms resulted in diversified agriculture with respect to crop calendar and period. In Rechna Doab the cropping seasons vary for individual crops but are generally defined as "Rabi" and "Kharif". Rabi crops (wheat and fodder) are sown after the rainy season in October and November, and harvested in spring in April and May. Kharif crops including cotton, rice, maize, sorghum and fodder are sown between April and June and harvested in October and November. The crop duration of major seasonal crops varies from 3 to 6 months. Sugarcane is a perennial crop. The Kc values developed for seven individuals (Sugarcane, Cotton, Rice, Maize, Kharif fodder, Wheat and Rabi fodder) and two groups of minor crops (kharif and Rabi). For the selection of crop period, longer period and high starting value is considered to accommodate preparation of land.

Potential Water Demand of different Crops

Monthly water demand of all individual and group of minor crops is estimated for three production areas. Total water demand is presented in Figure 4, which indicates water demand for most of crops increase from North to South e.g. for sugarcane it varies from 1407 and 1667 mm/year for Muridke and Shorkot production area. It is mainly due to the differences in reference evapotranspiration (Figure 3).

Figure 4: Variation in Water Demand of different Crops in Selected Production Areas.

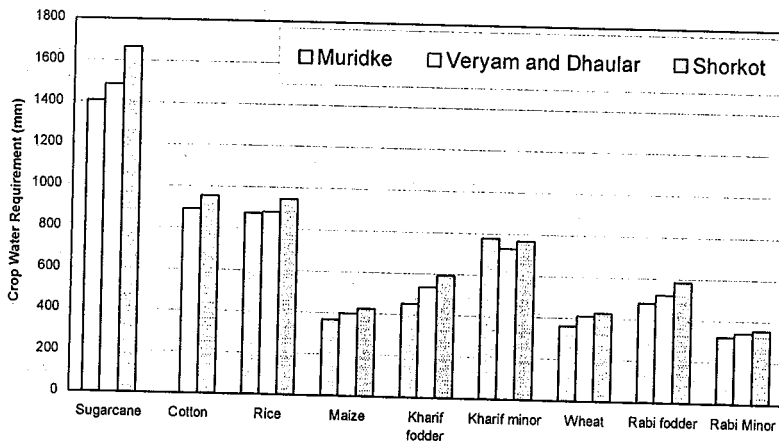

Net Water Demand of Different Crops

Monthly effective precipitation is calculated by USBR method to estimate the net water demand of different crops. The effective precipitation for the period April 1997 to March 2000 is presented in Figure 5. The effective rainfall shows decreasing trend in the last three years due to semi drought conditions in the area. Figure 5 shows that effective precipitation is highest in kharif 1997 and for Kharif 1999 the effective precipitation is almost equal to Rabi 1997-98 in most of areas. Similar to reference evapotranspiration rainfall is also higher in northern part as compared to southern part. For the past three years impact of lower effective rainfall is observed for all crops in area, which ultimately resulted in increased net demand of water. For example, water demand for sugarcane in Shorkot in last three years is shown in Figure 6. It has increased from 1238 mm/year in 1997-98 to

1531 mm/year in 1999-00. This increase of 297 mm is due to less rainfall during this period. Similar effect is also observed for all the selected crops in production area.

Figure 5: Temporal Variation of Effective Rainfall in Selected Production Areas

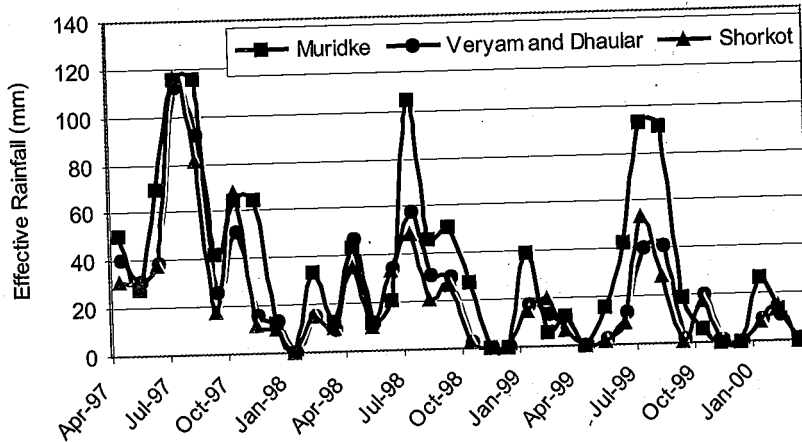
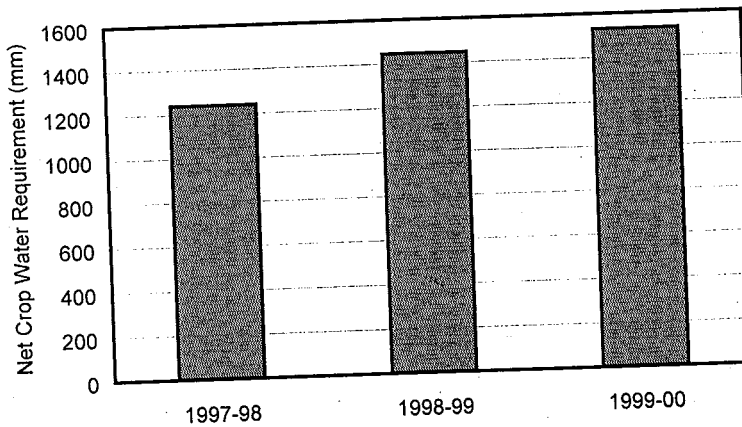

Figure 6: Annual Net Crop Water Demand for Sugarcane in Shorkot



Water Demand of Production Areas

For the estimation of net water demand of production area, spatial data for land use under different crops in each area was not available due to smaller land-holdings and mixed cropping patterns. The reported annual cropping intensities by Irrigation Department during 1997-2000 vary from 30 percent to 150 percent in upper and lower Rechna Doab respectively. This huge difference is due to the reason that upper Rechna Doab has fresh groundwater aquifer. The irrigation Department is supplying water only to a limited area in Kharif season. In the rest of the year the farmers have to depend on groundwater. To overcome this limitation, crop data on the intensity and pattern during Rabi and Kharif at canal command level was taken from the IWMI-Pakistan survey of 443 farms in the Lower Rechna Doab in 1997, and from another survey of about 400 farms in the Upper Rechna

Doab. The intensities of different crops are depicted from these sample surveys in selected production areas are given in the Table 2.

Table 2: Intensities of Different Crops in Selected Production Areas

	Sugar-cane	Cotton	Rice	Maize	Kharif Fodder	Kharif minor	Wheat	Rabi Fodder	Rabi minor
Muridke	0	0	75	0	10	2	57	21	2
Veryam and Dhaular	13	24	16	13	19	0	61	20	0
Shorkot	15	26	16	0	15	0	55	17	0

- Muridke has annual cropping intensity of 167 % with rice, wheat and rabi fodder are dominant crops.
- Veryam and Dhaular have annual cropping intensity of 166% with mixed cropping pattern in both seasons.
- Shorkot has annual cropping intensity of 126% with sugarcane, cotton, rice and fodder in Kharif and wheat with fodder in rabi.

The crop water demand for the production area is determined by using above-mentioned cropping intensities. The net monthly water demand for the existing cropping intensities for production areas is presented in Table 3. Water demand pattern for all three areas is more or less same - more demand in Kharif due to high evapotranspiration rate and less demand during Rabi due to low evapotranspiration rate.

Canal Water Availability to Crops

Canal water available to crops is calculated by subtracting all losses (main canal, distributary, water course, field losses with equation and assumptions discussed in methodology). This calculated volume of water on monthly basis for the selected production areas is given in the Table 4 and briefly discussed below.

- Muridke –a non-perennial system, the canal water was only supplied from May to October during the study period. The canal water available to crops had increasing trend in this period from 114 Mm³ in 1997-98 to 139 Mm³ in 1999-00. This excessive availability of canal water was to overcome the drought conditions during that period.

Table 3: Monthly Crop Water Demand (Mm³) for Selected Production Areas

Month	Veryam and Dhaular	Shorkot	Muridke	Month	Veryam and Dhaular	Shorkot	Muridke
Apr-97	68	34	13	Oct-98	139	87	40
May-97	99	58	35	Nov-98	93	40	32
Jun-97	171	91	85	Dec-98	68	32	23
Jul-97	88	46	39	Jan-99	41	22	3
Aug-97	83	53	29	Feb-99	73	28	35
Sep-97	126	66	60	Mar-99	131	56	55
Oct-97	51	25	11	Apr-99	137	55	39
Nov-97	66	32	0	May-99	124	70	42
Dec-97	48	25	16	Jun-99	199	107	102
Jan-98	65	32	26	Jul-99	169	77	52
Feb-98	69	32	19	Aug-99	141	75	43
Mar-98	128	54	55	Sep-99	158	74	73
Apr-98	59	32	15	Oct-99	100	73	65
May-98	116	66	45	Nov-99	92	40	32
Jun-98	175	94	116	Dec-99	68	32	23
Jul-98	145	79	45	Jan-00	53	26	10
Aug-98	154	78	69	Feb-00	76	32	31
Sep-98	121	62	55	Mar-00	143	61	63

Table 4: Monthly Canal Water Available (Mm³) to Crops in Selected Production Areas

Month	Muridke	Veryam and Dhaular	Shorkot	Month	Muridke	Veryam and Dhaular	Shorkot
Apr-97	0	52	26	Oct-98	15	58	32
May-97	9	57	42	Nov-98	0	59	22
Jun-97	28	61	43	Dec-98	0	50	24
Jul-97	32	59	46	Jan-99	0	0	3
Aug-97	24	57	34	Feb-99	0	37	11
Sep-97	13	45	34	Mar-99	0	56	30
Oct-97	9	55	26	Apr-99	0	59	32
Nov-97	0	64	26	May-99	4	58	45
Dec-97	0	55	18	Jun-99	27	55	38
Jan-98	0	8	6	Jul-99	35	55	46
Feb-98	0	53	22	Aug-99	27	58	47
Mar-98	0	59	32	Sep-99	33	53	46
Apr-98	0	60	37	Oct-99	13	57	16
May-98	13	53	41	Nov-99	0	34	24
Jun-98	30	51	40	Dec-99	0	51	38
Jul-98	33	55	45	Jan-00	0	26	9
Aug-98	18	57	45	Feb-00	0	51	14
Sep-98	29	55	44	Mar-00	0	61	15

- Veryam and Dhauhar-a perennial system, the canal water was supplied throughout the year. The canal water available to crops decreased during the study period, as the amount of water available to crops was 625, 590 and 618 Mm³ for the years 1997-98, 1998-99 and 1999-00 respectively. This was due to the fact that this system is located at tail of LCC-QB link nodal network model and upstream users consumed more water to combat drought conditions.
- Shorkot –a perennial system, the canal water was supplied during the whole period of study. The canal water available to crops increased from 354 Mm³ in 1997-98 to 376 Mm³ in 1998-99 and again decreases to 369 Mm³ in 1999-00. This fluctuation in water available to crops was due to operation plan of irrigation canal for that area.

Canal Water Availability Ratio (CWAR) and Groundwater Requirement

Based on analysis presented in the previous section, Canal Water Availability Ratio and groundwater requirement to meet crop water demand was calculated for the production areas selected from three nodal network models. The variability of CWAR and groundwater requirement is presented below for each selected production unit.

Muridke

Figure 7 shows the relationship between CWAR and groundwater requirement on monthly bases for 3 years. The CWAR ratio during the entire period of analysis is less than 1 as shown in Figure 7. This means that groundwater is required for each month to meet the crop water demand. As this area is non-perennial and water is available only from May to October, and even during these months CWAR is less than 0.5, which indicates that more contribution from groundwater was required than canal water. From November to April no canal water was available, so farmers fulfilled their needs only from groundwater. Figure 7 also shows that the maximum 86 Mm³ groundwater abstraction was required in June 1998 to meet demand of 116 Mm³ (Table 3) and the contribution of canal water to crops was only 30 Mm³ (Table 4). It also indicates that only in November 97, crop water demand was fulfilled by the excessive rainfall and no canal water as well as groundwater was required.

Figure 7: Water Balance in Muridke for the UCC-MR Nodal Network.

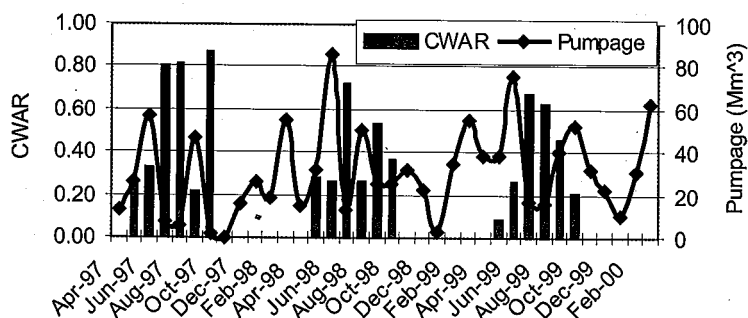

Veryam and Dhaular

The monthly relationship between CWAR and groundwater is presented in Figure 8. It indicates that October 1997, December 1997 and April 1998 were the only months that have CWAR more than 1, and in the remaining period contribution from groundwater was required. Overall CWAR is more in Rabi than in Kharif as shown in Figure 8. The monthly volume of water required to meet the crop demand varies from 41 Mm³ in January 1999 to 199 Mm³ in June 1999 (Table 3). In January 1999 there was no contribution from canal supplies and all demand was fulfilled by groundwater abstraction and in June 1999 canal supplies contributed 55 Mm³ (Table 4) and for remaining amount of 144 Mm³ the farmers had to depend on groundwater. In Kharif although more canal water was supplied but the demand was also more due to high evaporative requirement. This high demand increased the significance of groundwater contribution.

Figure 8: Water Balance in Veryam and Dhaular for the LCC-QB Nodal Network.

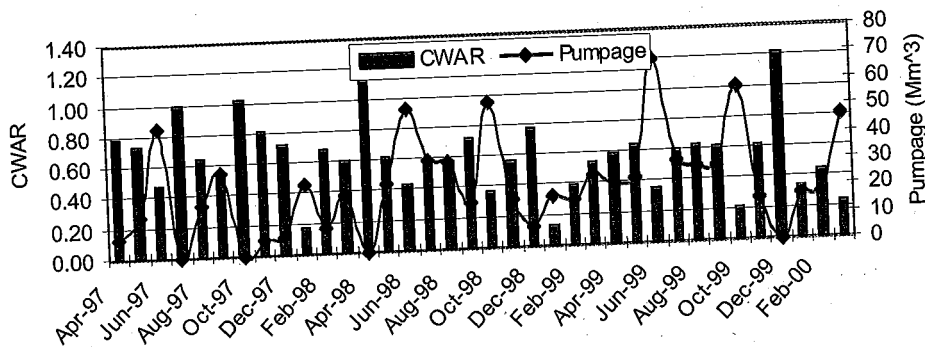

Shorkot

Figure 9 shows the variation of CWAR and required groundwater contribution during the study period from April 1997 to March 2000. There were only four months when canal water was sufficient to meet the crop water demand as shown in Figure 9. Except these four months, the farmers fulfilled their demand by supplementing irrigation through groundwater abstraction. Overall CWAR remained more than 0.5 for most of the time during the entire period of study and major contribution was from canal water in this production area. Figure 9 also indicates maximum required abstraction to meet crop demand was found 69 Mm³ in June 99 against the crop water demand of 107 Mm³ (Table 3) and the canal water available for crops during that month was only 38 Mm³. Similarly, even in January 1999 crop water demand of 22 Mm³ (Table 3) was estimated for which only 3 Mm³ (Table 4) of canal water was available to crops and remaining demand of 19 Mm³ (Figure 8) was assumed to be fulfilled by groundwater contribution.

Figure 9: Water Balance in Shorkot for the H-TS Nodal Network

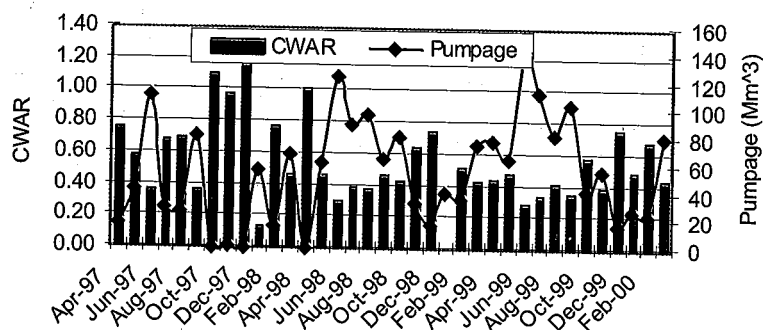

CONCLUSIONS

Based on above analysis in three production areas of nodal network models following conclusions are drawn:

- Low rainfall in past few years has been substituted with groundwater for better production of food and fiber.
- Surface water supplies are not enough to meet net crop water demand in most areas.
- Temporal variability in surface supplies has increased reliance on groundwater. Therefore, groundwater serves as a capacitor of the agriculture system.
- In non-perennial areas having canal water supplies from May to October, crop water demand during the remaining months was fulfilled completely from groundwater
- This strong spatio-temporal groundwater demand variability necessitates development of groundwater management zones, based on dynamic analysis.

REFERENCES

- Ahmad, N., 1988. Irrigated Agriculture of Pakistan. 61-B/2, Gulberg-III, Lahore, Pakistan.
- FAO, 1975. Crop Water Requirement, Irrigation and Drainage Paper No.24, Rome.
- FAO, 1998. Crop Evapotranspiration, Guidelines for Computing Crop Water Requirements, FAO Paper No. 56, Rome.
- GOP, 1997. Irrigation Agronomy, On Farm Water Management Field Manual, Volume IV, Federal Water Management Cell, Ministry of Food, Agriculture & Livestock, Islamabad.
- PARC, 1982. Consumptive Use of Water for Crops In Pakistan, Pakistan Agricultural Research Council, Islamabad.
- RAP, 1979. Revised Action Programme for irrigated Agriculture, WAPDA, Pakistan
- PPSGDPC, 1998. Crop water Requirements, Technical Report No. 26, PPSGDP, PMU, P&DD, Government of Pakistan
- Wayjen, E. G. Van., 1996. Study of Water and Salt Balances for Eight Sample Watercourse Commands in Chishtian Sub-Division, Punjab, Pakistan, IIMI Pakistan

Modeling Approaches to Quantify the Water Balance in Groundwater-Dominant Irrigation Systems - An Example of Rechna Doab Pakistan

S. Khan¹, M. Kaleem Ullah², E. Christen³ and H. M. Nafees Ahmad⁴

Abstract

Irrigated agriculture in alluvial basins is characterized by high seepage losses from rivers, channels and irrigated fields to the aquifer systems. Water accounting at the farm or management unit level tends to underestimate the productive use of water since losses from the supply system can be reused for irrigation through downstream groundwater pumping. In areas having less canal water supplies, pumping can mobilize poor quality groundwater and can cause overall loss of good quality ("blue") water supplies. Increased groundwater pumping also causes enhanced seepage losses from irrigation channels and watercourses. This situation demands understanding of spatial and temporal variation of surface and groundwater interactions and salt movements under variable scenarios of surface water availability.

This paper describes details of hydrological studies carried out during the past couple of years in Rechna 'Doab' (land between two rivers) in Pakistan. The gross area of Rechna Doab is 2.97 million ha, with a longitudinal extent of 403 km and maximum width of 113 km, comprises of 2.3 million ha of prime cultivated land. It is one of the oldest, agriculturally richest and most intensively populated irrigated areas of Punjab. The area falls in the rice-wheat and sugar-cane wheat agro climatic zones of the Punjab province, with rice, cotton and fodder crops dominating in summer (Kharif), wheat and fodder in winter (Rabi). In some parts sugar cane is also cultivated as an annual crop.

A top down nodal network approach was developed to determine irrigation water balance for the individual administrative units within Rechna Doab. The spatial groundwater recharge estimates obtained from the nodal network framework were used as sanity checks for the water balance estimates for a more distributed bottom up approach. The bottom up approach utilized a distributed dynamic model, which could simulate surface and groundwater interactions at the desired level of interest. The distributed nature of the surface-groundwater interaction model enabled performance assessment of individual administrative units by taking into account downstream beneficial use and quality variation of lost surface water resource. This water and salt balance approach has highlighted

¹Senior Research Scientist, CSIRO Land and Water PMB 3, Griffith, NSW 2680, Australia

²Junior Civil Engineer, International Water Management Institute (IWMI), Lahore, Pakistan

³Irrigation and Drainage Engineer (Research), CSIRO, Land and Water, Griffith, NSW, Australia

⁴Research Officer, Pakistan Council of Research in Water Resources (PCRWR)

the need for integrated management of surface and groundwater from the administration unit to the hydrological basin level.

INTRODUCTION

In groundwater dominant irrigation systems crop water demands are conjunctively met by surface and groundwater. While it is important to ensure efficient use of surface water supplies (e.g. more grains per drop of water) by improved transmission and irrigation methods, this may cause reduced recharge to aquifers and hence lower availability of water to farmers relying on groundwater for agriculture. This problem demands a system's approach to determine water balance at different scales as deep percolation losses from one administrative or hydrologic unit may be reused in another unit (Rushton, 1999; Seckler, 1996). The water lost through deep percolation from one hydrological unit goes through geochemical changes before it becomes available as groundwater in another hydrological unit. This aspect may necessitate consideration of water quality implications in upscaling efforts in groundwater dominant systems.

Often, water rights are associated with administrative units irrespective of the hydrological interactions and boundaries of the system. This necessitates determination of water use efficiency at each of the administrative units and how it contributes to the overall system's efficiency. The quantitative assessment of water productivity or water use efficiency requires a range of methodologies which can capture system water and salt dynamics at both the hydrological and administrative scales. This paper describes two approaches for understanding the role of both surface water and groundwater in meeting crop water demand at administrative and hydrological unit levels in Rechna Doab, Pakistan.

DESCRIPTION OF STUDY AREA

The Rechna 'Doab' (land between two rivers) is the interfluvial sedimentary basin of the Chenab and Ravi Rivers in Pakistan (Fig-1). It lies between longitude 71° 48' to 75° 20' East and latitude 30° 31' to 32° 51' North. The gross area of Rechna Doab is 2.97 million ha, with a longitudinal extent of 403 km and maximum width of 113 km and comprises 2.3 million ha of prime cultivated land. It is one of the oldest, agriculturally richest and most intensively populated irrigated areas of Punjab, Pakistan. The flows of the Chenab and Ravi rivers bounding the Rechna Doab are regulated through six major headworks. Four of these headworks, Marala, Khanki, Qadirabad and Trimmu are on the Chenab River while Balloki and Sidhnai Headworks are on the Ravi River. These headworks enable diversions to the main and link canals servicing the irrigation areas. The Chenab and the Ravi River meet about 64.4 km further downstream of the Trimmu Headworks at the lower tip of the Rechna Doab area. Two main canals and five link canals take supplies from the Chenab River. The Upper Chenab Canal (UCC) and Lower Chenab Canals (LCC) are the main supply canals, off taking at the Marala and Khanki Headworks, respectively. The five link canals Marala-Ravi (MR), BRBD (Bambanwala-Ravi-Bedian-Depalpur), Qadirabad-Balloki (QB), Trimmu-Sidhnai (TS), and Haveli mainly transfer water from the Chenab River to the Ravi River. Some of these link canals were constructed after the Indus Basin Treaty in 1960s, which gave India exclusive rights on the Ravi River greatly restricting flows into the Pakistani part of this river.

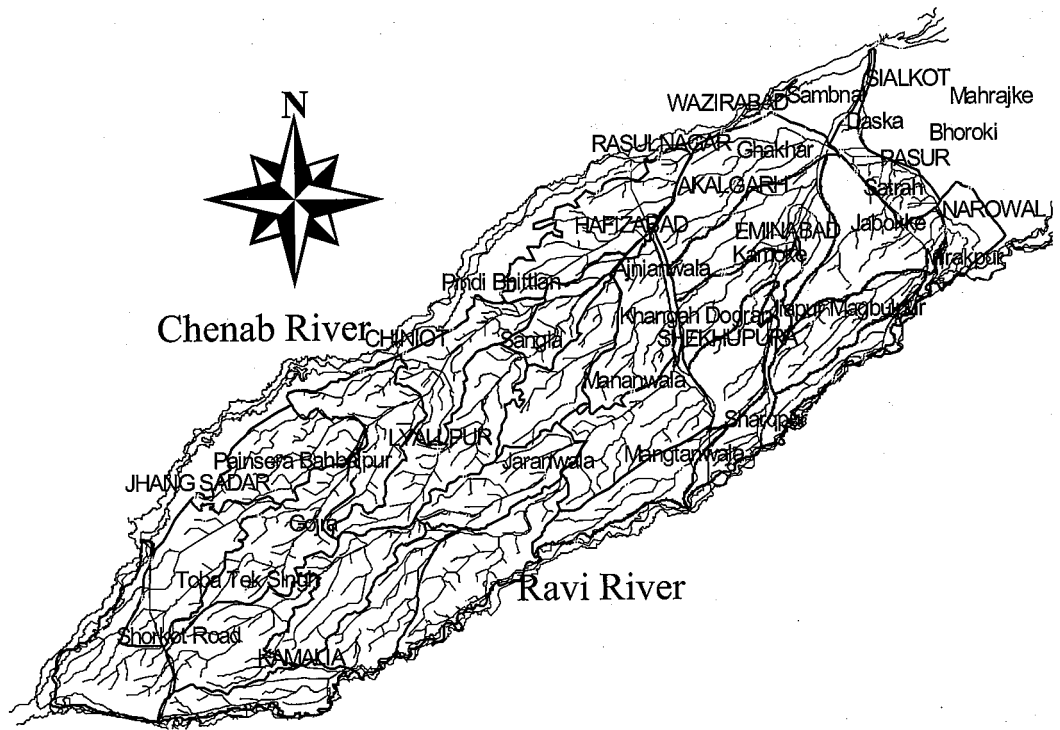

Figure 1: Rechna Doab Irrigation System

The study area falls in the rice-wheat and sugar cane-wheat agro-climatic zones of Punjab province, with rice, cotton and fodder crops dominating in summer season (Kharif), and wheat and fodder in winter season (Rabi). In some parts, sugar cane is also cultivated as an annual crop. At the time of construction the irrigation network was designed for supporting low cropping intensities; however, success of groundwater pumping to alleviate waterlogging and salinity problems in the late sixties helped increase the cropping intensities well over 150%, with the rapid development of public and private tubewells. The groundwater storage underlying the Rechna Doab has served as a vital irrigation resource to support these increased irrigation intensities.

The Rechna Doab is sub tropical, continental lowland often described as a semi arid region. The climate is characterized by large seasonal fluctuations of rainfall and temperature. Average annual precipitation varies from 290mm in the south (Shorkot) to 1046mm in the north (Sialkot) of the Doab. The highest rainfall occurs during the monsoon period in July and August and accounts for about 60 percent of annual rainfall. Due to the short time span of the monsoon, a large volume of rainfall is wasted, often causing floods. In the last three years the monthly effective rainfall (Fig. 2) available for crop production (Soil Conservation Service 1972) throughout the Rechna Doab has been very low. However, no substantial reductions in crop yields have been reported in the region. This illustrates increased dependence on groundwater resources to maintain the cropping patterns.

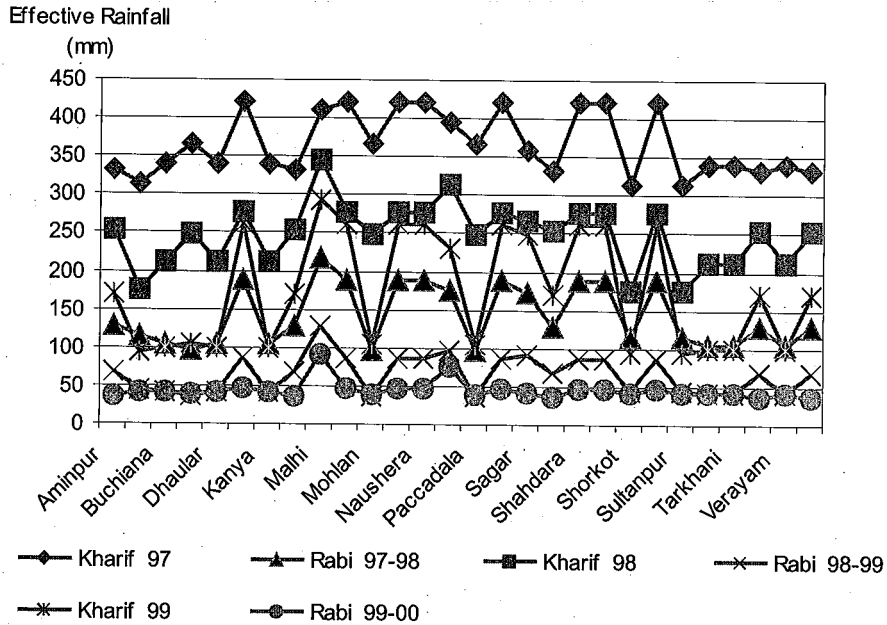

Figure 2: Effective Annual Rainfall in Rechna Doab from 1997-2000

WATER BALANCE ANALYSIS AT THE SYSTEM SCALE

Realizing the importance of surface-groundwater interactions the following two approaches were used to understand the role of groundwater to meet crop demand on both hydrological and administrative area bases:

- Top down approach using a nodal network model
- Bottom up approach using a surface-groundwater interaction model

The first approach subdivides the study area into a system of channel reaches and demand nodes linking the channel reaches, and therefore, follows the topography of the area. This approach recognizes the data limitations e.g. availability of groundwater pumping rates, and therefore, builds the desired complexity into the analysis only to answer specific questions.

The second approach subdivides the area into a number of connected square grid cells in four layers which can dynamically simulate the surface-groundwater interactions under varying depths and quality of groundwater abstractions represented by model layers. The second approach assumes better knowledge of the system and can integrate water and salt balances from individual cells up to the hydrologic or administrative unit level.

Top Down Approach

The study area was divided into three nodal networks reflecting the direction of surface water flow and connectivities of canals between the Chenab and Ravi rivers as given below (Fig-1):

- Upper Chenab Canal and Marala Ravi Link Canal (UCC-MR) Fig-3
- Lower Chenab Canal and QB Link Canal (LCC-QB)
- Haveli and Trimu Sidhnai Link Canal (Haveli-TS)

A lumped monthly water balance was determined for each of the demand nodes using monthly canal supplies, irrigation system loss estimates and net crop water requirement. This approach helped determine groundwater requirements by finding the difference between monthly water supplies and crop demand volumes in Mm^3 using Equation 1:

$$VGW = VNCWR - (VCH - VL) \quad (1)$$

where

$$VL = VMCL - VDL - VWCL - VFL \quad (2)$$

$$VNCWR = \Sigma(ET_o \times K_c) - \text{Effective Rainfall} \quad (3)$$

VCH = Volume water at head of network reach from canal flow data

VL = Volume of all water losses

VGW = Volume of groundwater required to meet crop water demand

VMCL = Main canal seepage and evaporation losses

VDL = Distributary seepage and evaporation losses

VWCL = Water course seepage and evaporation losses

VFL = Field seepage and evaporation losses

VNCWR = Volume of net crop water requirement

ET_o = Potential crop water determined using Penman Monteith equation (FAO, 1998)

K_c = Crop Factors for individual crops grown in the demand area

Effective Rainfall = Rainfall available to crop after losses determined using Soil Conservation Service (1972)

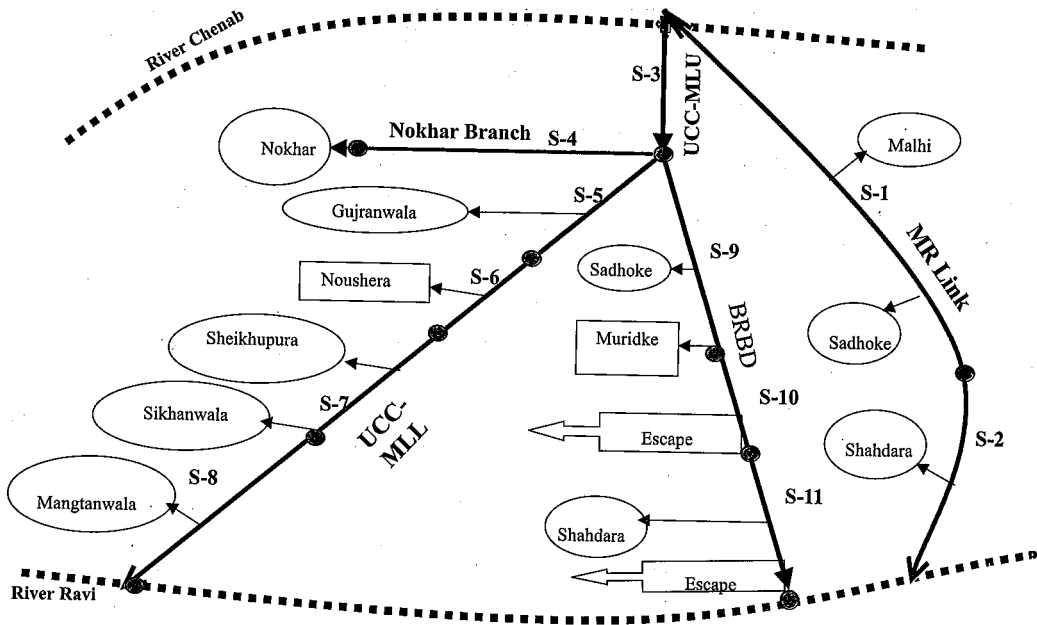

Figure 3: Upper Chenab Canal and Marala Ravi Link Canal Nodal Network

To visualize the role of surface water in meeting crop demand, monthly canal water availability ratios (CWAR) were determined for each of the demand nodes using Equation-4.

$$CWAR = (VCH - VL) / VGW \quad (4)$$

To illustrate the usefulness of this technique results at two demand nodes are presented in this paper.

WATER BALANCE FOR A NODE LOCATED IN THE UPPER PART OF THE SYSTEM

Figure-4 shows the CWAR and groundwater demand at the Nokhar demand node for 1997-2000 for the UCC-BRBD Nodal Network (Fig-3). Although the Nokhar demand area is non perennial (supplies only in summer) and is located at the upper end of the irrigation system, results show that, both during summer and winter, the canal water supplies are not enough to meet crop demand and substantial groundwater pumping is necessary throughout the year.

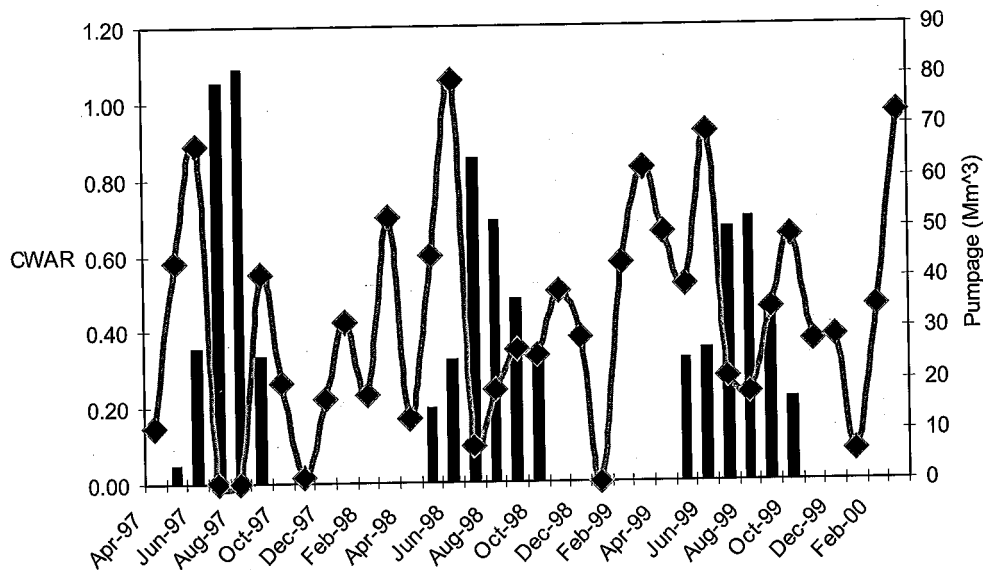

Figure 4: Canal Water Availability Ratio (CWAR; solid bars) and pumping volume (line) in the upper end of the UCC-MR Nodal Network

WATER BALANCE FOR A NODE LOCATED IN THE LOWER PART OF THE SYSTEM

Fig-5 shows the CWAR and groundwater demand at the Mangtanwala demand node for 1997-2000 located at the lower end of UCC-BRBD Nodal Network (Fig-3). Water balance shows that the surface water supplies are not enough to meet the crop water demand in both the winter and summer seasons. Similar results were obtained for the other demand areas in the Rechna Doab system, and therefore, indicating strong dependence of irrigated agriculture on groundwater.

This analysis helped to establish lumped spatial distribution of crop water demand, surface water availability, system losses and groundwater demand along with the irrigation supply system. This methodology can provide a better understanding of surface and groundwater use efficiency on a nodal area basis but failed to quantify contribution of losses from one part of the system to the groundwater gains in the other part.

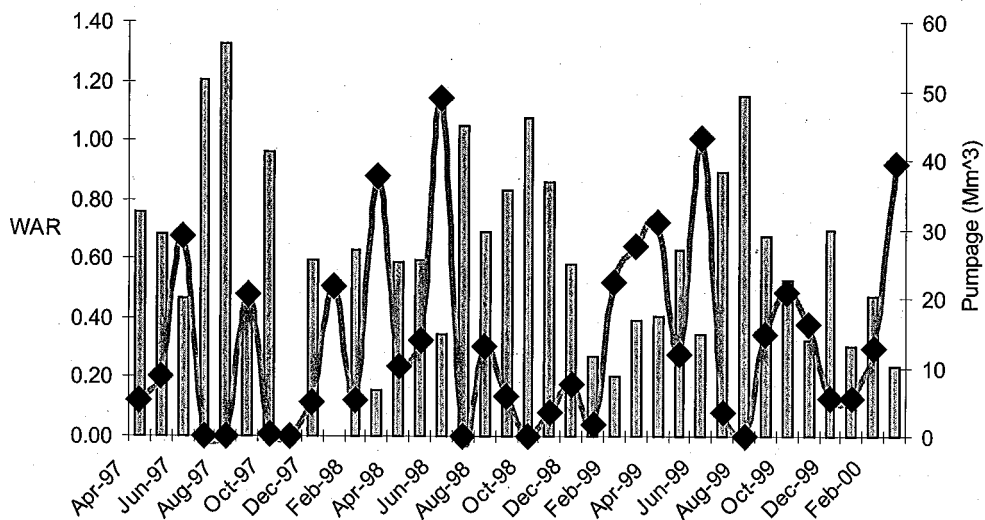

Figure 5: Canal Water Availability Ratio (WAR; solid bars) and pumping volume (line) in the lower end of the UCC-MR Nodal Network

Example of a Bottom Up Approach

In bottom up approaches the biophysical processes are scaled up to the desired level of interest using biophysical parameters and process simulation at a more detailed level. In the case of Rechna Doab the system was described using a surface-groundwater interaction model by dividing the study area into $4 \times 106 \times 132$, 2.5 km finite difference cells in four aquifer layers using MODFLOW and MT3D (Harbaugh and Macdonald, 1996; Zheng, 1996; Khan, 2001). This arrangement required aquifer lithology, surface water interaction parameters, and water quality, recharge and discharge parameters descriptions on a 2.5 km grid. This finer level of system description helped incorporate biophysical constraints to groundwater movement such as heterogeneity of alluvial aquifer properties and spatial variation in aquifer thickness.

Bennett et al. (1967) provided a detailed hydrologic description of the aquifer systems in the Rechna Doab. The Rechna Doab aquifer system has a major discontinuity due to a bedrock outcrop near Chiniot (Fig. 6) which divides it into two semi dependent basins. The spatial variation in the thickness of Rechna Doab alluvium is shown in Fig-7. The alluvial sediments mainly consist of gray and grayish-brown fine to medium sand, silty sand, silt and clay (Khan, 1978). The composite hydraulic conductivities of the alluvium range from 25 m/day to 150 m/day. The shallow groundwater quality (Fig. 8) in the upper part of the Doab has low salinity (EC less than 1000 $\mu\text{S}/\text{cm}$) whereas the lower part of the Doab has higher groundwater salinity (EC ranging from 5000-25000 $\mu\text{S}/\text{cm}$).

Using the geometrical description of the surface water network (rivers and channels) the surface-groundwater interaction parameters were defined in the model. The groundwater parameters such as hydraulic properties, recharge, water quality, evapotranspiration from the phreatic surface and groundwater pumping were described on a cell by cell basis for each of the corresponding layers in the model. The evapotranspiration from the phreatic surface depends on soil type, depth to

watertable and land use. It consists of capillary upflow caused by plant roots or suction caused at the soil surface due to evaporation. This model used water balance estimates from the nodal network approach as sanity checks for water budget outputs. The combined description of surface and groundwater systems at a finer scale helped dynamically simulate system response to changing surface-water availability and rainfall scenarios on a seasonal basis.

The model was calibrated for a seven-year period from June 1993 to June 2000 at 190 piezometric locations throughout the Rechna Doab.

To illustrate the usefulness of this bottom up approach, model results for a 10-year simulation (June 1993 to June 2003) are presented here. These include a historic simulation period from June 1993 to June 2000 (calibration period) and a forecast period from October 2000 to June 2003 using year 2000 climate and an increased groundwater pumping regime due to recent dry weather conditions. Fig-9 shows simulated and observed piezometric levels at a representative location in the middle of the Doab. The cyclic nature of the simulated and observed hydrographs in the initial five years shows that groundwater in the aquifer is stored during the summer period due to excessive recharge from the rivers, channel network and field losses and is used during the winter period. During the last two years of the historic simulation period the watertables show a declining trend. The declining groundwater trend continues for the forecast simulation period due to increased groundwater pumping and lower surface water supplies (caused by lower than average rainfall). This situation demands careful groundwater management in the Doab as over exploitation of groundwater can make pumping operations expensive, and can also mobilize saline groundwater.

Figs-10 and 11 show the groundwater balance scaled up to the Doab level for the Rabi (winter) 1996 and Kharif (summer) 1996 periods respectively. This water balance helps visualise the relative magnitudes of groundwater pumping (WELLS), and evapotranspiration from watertable (ET) and groundwater recharge (RECHARGE), river and channel seepage and change in groundwater storage on the entire Doab basis. The positive storage terms indicate that during Rabi groundwater demand is partly met from aquifer storage component and negative storage terms show that during Kharif excessive groundwater recharge is stored in the aquifer.

Fig-12 shows the predicted June 2003 groundwater levels in the Rechna Doab. Due to strong dependence on groundwater lower parts of the Doab develop watertable depressions with depths greater than 15 meters, which can make groundwater pumping uneconomical for the farmers due to many fold increase in the capital and operating costs. These watertable depressions can also cause mobilization of saline groundwater from adjacent regions and from deeper groundwater. An example of degrading water quality with increased groundwater pumping under continued dry climate conditions for the lower part of the Doab (Haveli Division L-03/3) is given in Fig-13.

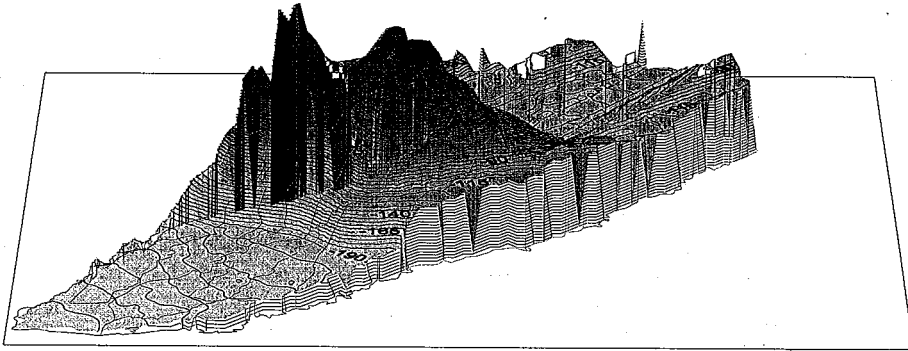

Figure 6: Shape of the Bedrock Surface Under the Rechna Doab [numbers indicate depth from mean sea level]

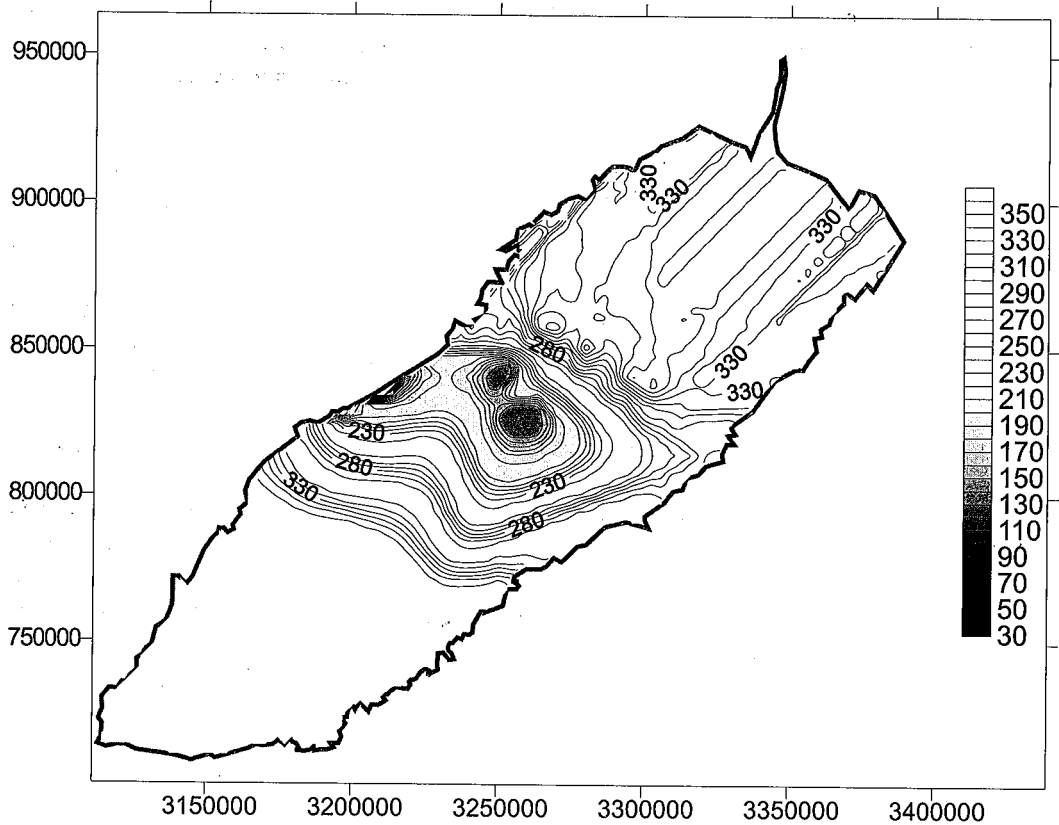

Figure 7: Thickness of Aquifers under the Rechna Doab in m, horizontal and vertical axis show UTM coordinates

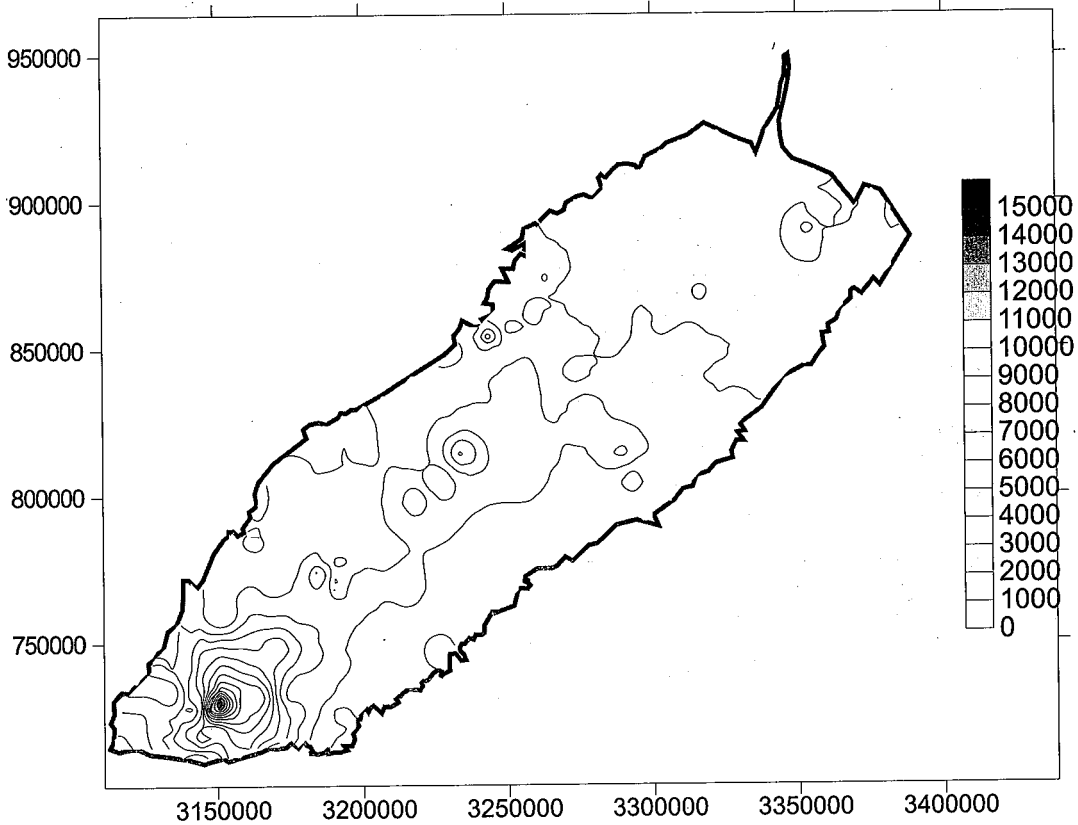

Figure 8: Groundwater Salinity under the Rechna Doab ($\mu\text{S}/\text{cm}$) horizontal and vertical axis show UTM coordinates

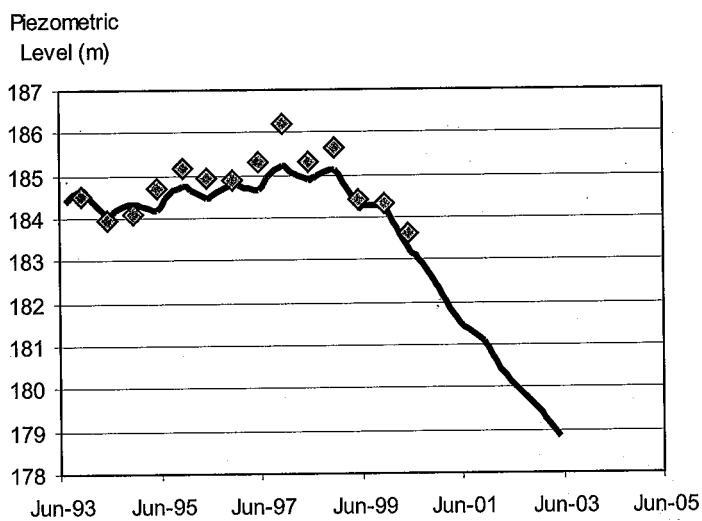

Figure 9: Observed (dots) and Predicted Groundwater Levels (line) at Piezometer L-28/11 located in the middle of Doab

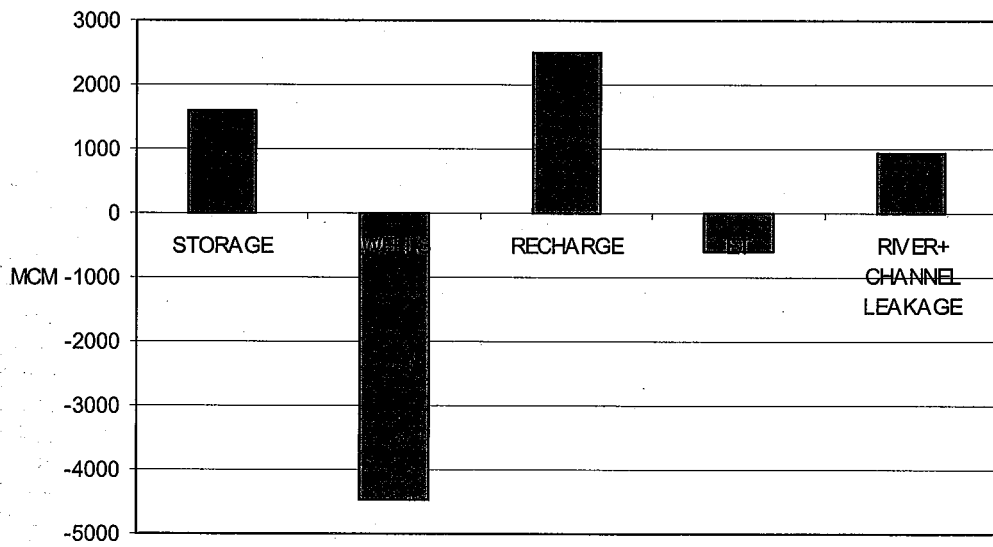

Figure 10: Rabi 1996 Groundwater Balance for Rechna Doab, (MCM=Million Cubic Meter)

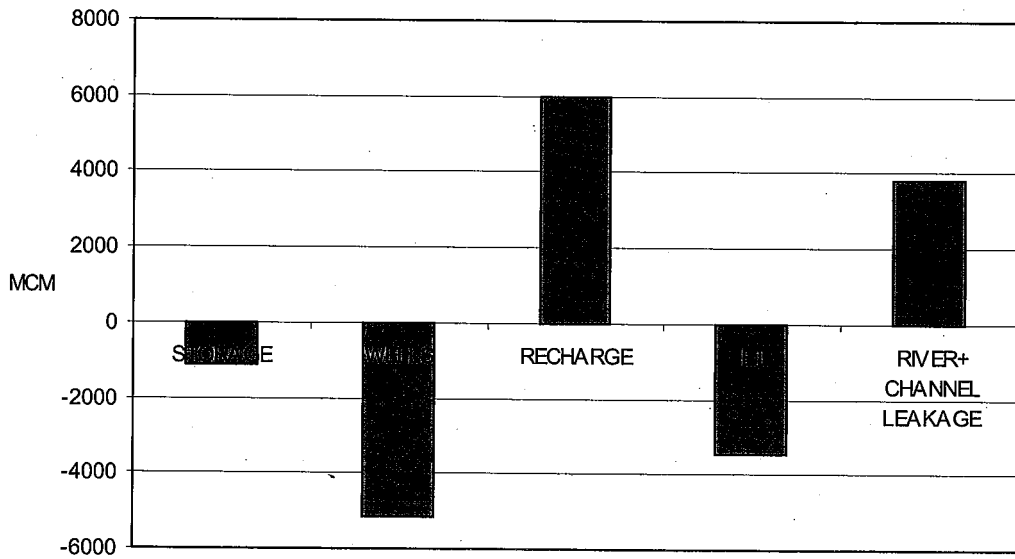

Figure 11: Kharif 1997 Groundwater Balance for Rechna Doab (MCM=Million Cubic Meter)

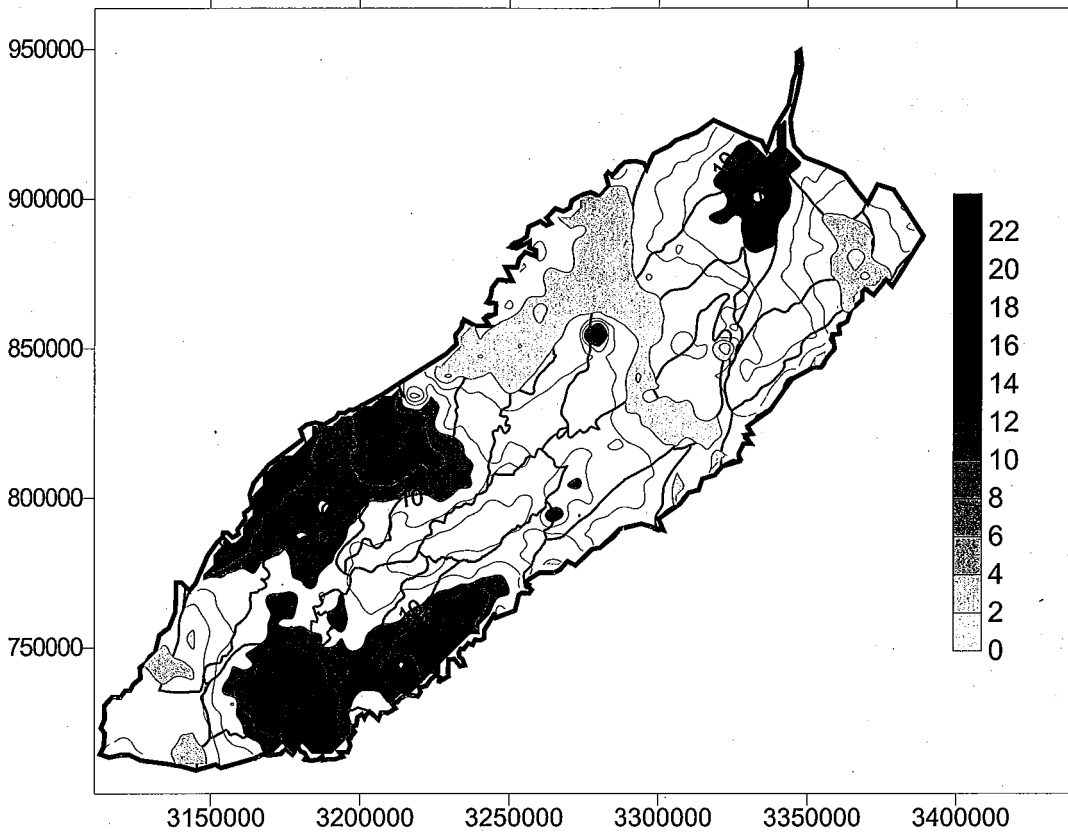

Figure 12: Predicted Depth to Watertable for June 2003 under the Rechna Doab in m below soil surface, horizontal and vertical axis show UTM coordinates

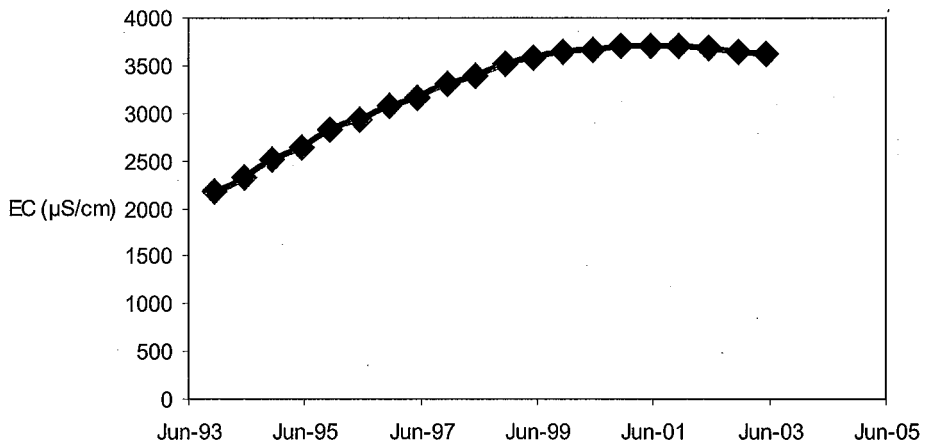

Figure 13: Predicted Salinity Trends in the Shallow Aquifer under the Haveli Division L-03/3

CONCLUSIONS

This paper has demonstrated two approaches for quantifying surface and groundwater balance in groundwater dominant systems. The top down approach is useful in situations where data on the distributed features of the system are scarce, while the bottom up approach is more suitable for data rich environments. The top down approaches can help get a handle on relative quantities of different hydrologic components distributed along the supply system. This type of methodology is recommended for rationalization of resource allocations along supply networks. However, this approach fails to quantify how losses from one demand node can become gains to other demand nodes in the system and how water quality transformations take place in this process.

The bottom up approaches offer integration of information from a lower level to any desired level of detail but demand huge data sets and intellectual investments. Their distributed nature can help represent system discontinuities and heterogeneity. These approaches can easily couple with water quality accounting methods and add the vital water quality dimension to the water balance debate.

The distributed nature of bottom up approaches facilitates lumping of water balance at the desired hydrologic or administrative units. The ability to link groundwater balance with water quality dynamics offers a tremendous tool for policy makers for defining rational productive use of surface water and groundwater without compromising the environmental conditions.

The water balance studies for Rechna Doab have shown that during Rabi crop water demand is partly met from mining of aquifer storage and while during Kharif excessive groundwater recharge is stored in the aquifer. Because of strong dependence on groundwater lower parts of the Doab, long term sustainability of this vital resource is threatened due to development of watertable depressions with depths greater than 15 meters, which can make groundwater pumping uneconomical for the farmers due to manifold increase in the capital and operating costs. These watertable depressions cause mobilization of saline groundwater from adjacent regions and from deeper groundwater.

ACKNOWLEDGEMENTS

The authors wish to acknowledge Shamshad Gohar and Ahmed Nawaz of National Engineering Services of Pakistan (NESPAK) and Akhtar Hussain Shah of the Punjab Irrigation Department (PID) for the data sets used in this work. Project funding from Australian Centre for International Agricultural Research (ACIAR) is highly appreciated. Review comments from Dr Liz Humphreys helped improved the quality of manuscript.

REFERENCES

- Bennett, G. D., A. Rehman, I. A. Sheikh, and S. Ali. 1967. Analysis of aquifer tests in the Punjab region of West Pakistan. US Geological Survey Water Supply Paper 1608-G, 56p.
- FAO (Food and Agriculture Organisation). 1998. Crop evapotranspiration - Guidelines for computing crop water requirements - FAO Irrigation and drainage paper 56.
- Harbaugh, A.W. and M. G. McDonald. 1996. User's documentation for MODFLOW-96, an update to the U.S. Geological Survey modular finite-difference ground-water flow model, USGS Open-File Report 96-485.

- Khan, M. A. 1978. Hydrological data, Rechna Doab, Volume I. Lithology, mechanical analysis and water quality data of testholes/testwells. Publication Number 25, Project Planning Organization (NZ), Pakistan Water and Power Development Authority, Lahore.
- Khan, S. (2001) Hydrological economic models for developing policies for irrigated agriculture. In: Donna Brennan editor. Water Policies Reform: Lessons from Asia and Australia. Proceedings of the International Workshop held in Bangkok, Thailand, 8-9 June 2001. Australian Centre for International Agricultural Research (ACIAR) Proceedings No. 106. 269-280.
- Rushton, K.R., (1999) Groundwater aspects: losses are inevitable but re-use is possible? Agricultural Water Management 40,111-116
- Seckler, D., (1996) The new era of water resources management: From 'dry' to 'wet' savings. Research Report No. 1, International Irrigation Management Institute, Colombo.
- Soil Conservation Service (1972) National Engineering Handbook, Hydrology. Section 4.
- Zheng, C., 1996, MT3D Version DoD_1.5, a modular three-dimensional transport model, The Hydrogeology Group, University of Alabama.

Controlling Groundwater Tables Through Localized Sub-Surface Evaporation Basin: A Case Study of Rechna Doab

H. M. Nafees Ahmad¹, M. Kaleem Ullah² and Asad S. Qureshi³

ABSTRACT

In the Indus basin, under valley movement of groundwater is very limited due to its flat topography. However, the micro relieves provide some natural gradient for groundwater to flow in the low laying areas within the basin giving rise to watertable and inducing soil salinity. Drainage of these areas is complex as there is no outlet to dispose of the drainage effluent. This necessitates the need for exploring alternative localized drainage solutions for the reclamation of these lands. One approach could be to use these low laying areas as permanent discharge sites for providing drainage to the abutting areas. By digging sub-surface evaporation basins (SEB), the shallow groundwater of these areas can be directly exposed to the atmosphere. This will increase the rate of groundwater evaporation equivalent to the open water evaporation. Due to difference in gradient, the influx of groundwater to the sub-surface basin will increase resulting in watertable declines in the adjoining areas. This paper presents the results of field study carried out in the Rechna Doab of Pakistan to evaluate the effectiveness of sub-surface evaporation basin to reclaim shallow watertable soils. The field data collected over thirteen months indicate that gradient has been developed towards SEB from all sides, after nine months. The field data is also used to calibrate the groundwater flow model MODFLOW. The calibrated model is then used to calculate number of scenarios to study different design parameters of the sub-surface evaporation basin and their effect on groundwater flow regimes.

INTRODUCTION

Pakistan has one of the loftiest irrigation systems in the world. This irrigation network is mainly confined to Indus Basin, which is irrigating an area of about 16 million hectare. At the time of introduction of this large-scale irrigation system, provision of subsurface drainage as a part of irrigation system was not felt because the groundwater table depth was ranged between 20 to 30 m below the soil surface in different canal command areas (Sarwar, 2000). The operation of the Indus Basin irrigation system is based on a continuous water supply and is not related to actual crop water requirement. Thus, due to inadequate drainage system and continuous seepage over the years from unlined earthen canals and from a large network of distributing channels and percolation losses from irrigated fields, the groundwater table increased rapidly within the crop root-zone (1.5 m). This

¹ Research Officer, Pakistan Council of Research in Water Resources (PCRWR), Lahore, Pakistan

² Junior Civil Engineer, International Water Management Institute (IWMI), Lahore, Pakistan

³ Acting Regional Director, IWMI Regional Office, Lahore, Pakistan

created the environmental problems like waterlogging and salinity that have badly affected the agricultural productivity. Mirbahar and Sipraw (2000) reported that Pakistan has 37.5% of gross command area (GCA) as waterlogged (watertable shallower than 3m below the surface) of which 15% is severely waterlogged (watertable shallower than 1.5m).

Due to flat nature of the Indus Basin, natural subsurface drainage through down-valley movement of groundwater is very limited. However, the micro relieves provide some natural gradient for groundwater to flow in the low laying areas within the basin giving rise to watertable and inducing soil salinity. Disposal of drainage water from these areas, specially the isolated farms, which have no setup of surface/subsurface drainage, is a serious problem. To dispose of the drainage effluent from these areas it is important to explore some alternative drainage solutions for the reclamation of these lands at farm level. One option could be to use these low laying areas as permanent discharge sites for providing drainage to the abutting areas. By digging sub-surface evaporation basins (SEB), the shallow groundwater of these areas can be directly exposed to the atmosphere. This will increase the rate of groundwater evaporation than the bare soil evaporation. Due to difference in gradient, the groundwater will move towards the sub-surface evaporation basin and thus declining watertable in the adjoining areas (Figure 1). Singh and Christen (2001) reported different options being practiced in Australia, for the removal of saline effluent from irrigated areas. According to the authors, evaporation basins are accepted as a viable, short and long-term disposal option among the other options like: river disposal, disposal bores, pipeline to the sea, and desalination. Thus, a field experiment was done in Rechna Doab area to check this approach. The main objective of this study was “to evaluate the effectiveness of sub-surface evaporation basin for watertable control in low lying areas”.

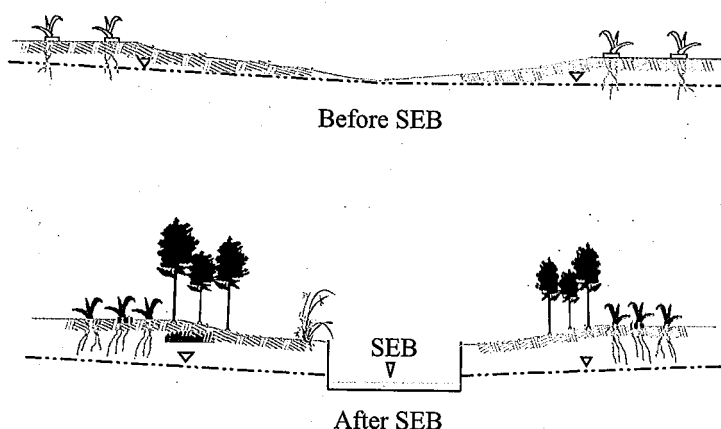

Figure 1: SEB conceptual framework.

EXPERIMENTAL DESIGN

The subsurface evaporation basin (SEB) experiment was conducted at Soil Salinity Research Institute (SSRI), Pindi Bhattian. An area of four hectares, left abandoned due to waterlogging and salinity, was selected for this experiment. The area had sandy clay loam texture with the loam surface. SEB was constructed in the center of the experimental area. On the western side of the study area, there was guava orchard, have mixed cropping with rice-wheat rotation in kharif and rabi, respectively.

The dimensions of SEB were $36.58 \times 36.58 \times 1.83 \text{ m}^3$ ($120 \times 120 \times 6 \text{ ft}^3$). Slope of 1:1.5 was given to all four sides of SEB. To check runoff into SEB from rainfall or from irrigation to adjacent fields, a $3.05 \times 0.61 \text{ m}^2$ ($10 \times 2 \text{ ft}^2$) bank was constructed around the SEB. Perforated pipe of 10.16 cm (4 inch) diameter was installed at east and north side of SEB, to measure the water level within the evaporation basin.

To see the effect of SEB on groundwater levels in the vicinity area, a network of sixteen piezometers was planned at 1.52, 15.24, 30.48, and 45.72 meter (5, 50, 100 and 150 ft respectively) distance from each corner of SEB. The schematic diagram of piezometers network is shown in Figure 2.

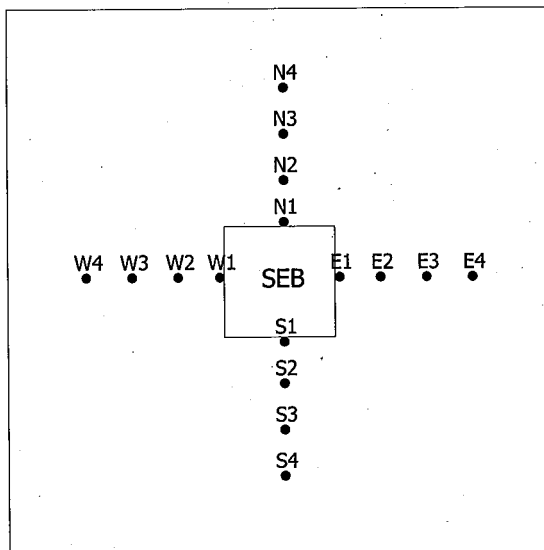

Figure 2: Schematic diagram of piezometer network at experimental site.

EXPERIMENTAL MEASUREMENTS

The experimental measurements aimed to see the effect of SEB on water tables in the area. The groundwater piezometric level was monitored using piezometers network made of 38 mm PVC pipe 3.96 m deep, with 0.91 m screen covered with cloth. After lowering the piezometer pipes in the boreholes, concrete structures were made for leveling as well as security purposes. The concrete structure was made in 38.7 cm^2 shape from top and 10.16 cm in depth. The length of blind pipe above this structure was about 15-20 cm. Thus the total length of the piezometric pipe in the ground was 3.66 m. The piezometers were sealed from the bottom by bail plug. The water level indicator (WLI) was used to collect the groundwater levels data. The WLI consists of a probe, a graduated cable or tape, and a cable reel with built-in electronics. The probe was lowered down in the piezometer until the buzzer indicated contact with water. Depth-to-water measurement was read from the tape. The water level in the piezometers was monitored on weekly basis for thirteen months. Drawing lithological logs at piezometer sites, lithological information was also collected. Rainfall was measured on the site with rain gauge.

One of the key components for the evaluation of SEB is evaporation. It is a useful tool to identify any significant change in the basin performance. Daily pan evaporation was measured using the

four-foot diameter Class-A evaporation pan. The pan water level reading was adjusted when rainfall was measured, to obtain the actual evaporation. Figure 3 shows the weekly average values of pan evaporation during the study period.

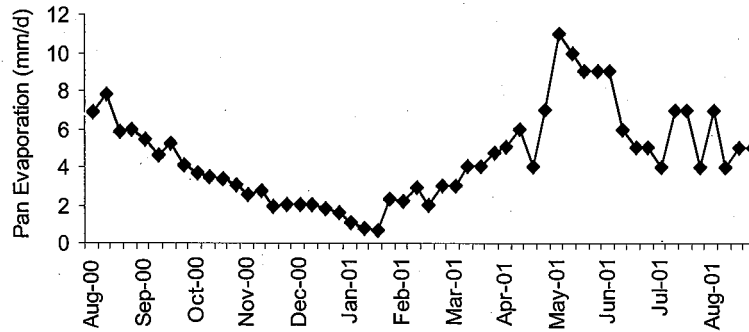

Figure 3: Weekly averages (mm/d) of pan evaporation during the study period.

GROUNDWATER LEVEL FLUCTUATIONS

Figure 4 shows the well drain-ability of the soil. Whenever there is rain, it has quick impact on groundwater levels of the study area. In this figure, groundwater

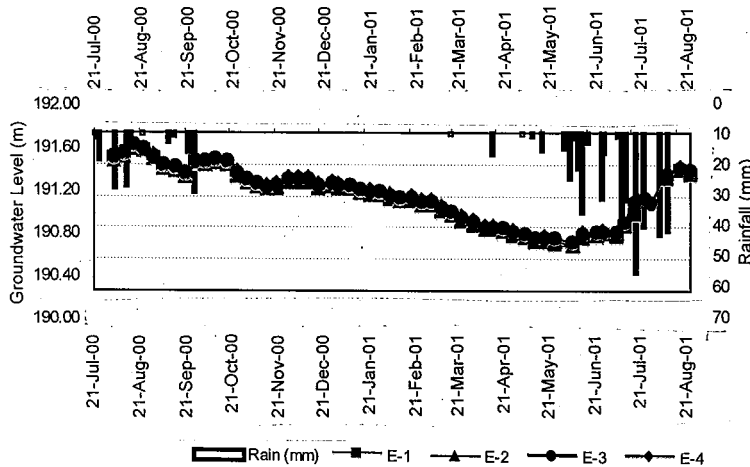

Figure 4 Effect of rainfall on groundwater fluctuations.

fluctuations data for all piezometers located in eastern side of SEB were plotted. Maximum water level of 191.82 m with a minimum value of 190.60 m was observed in the piezometer E-3 over the study period. Similar trend was also observed for the piezometers on northern, southern and western sides of the evaporation basin.

MODEL APPLICATION

Mathematical modeling is commonly used for simulating groundwater systems with complex behaviors as it permits the predictions of the response of the aquifer to applied stresses and presents alternative suggestions for its use. In this study PMWIN (Chiang and Kinzelbach, 1996), which is a complete simulation system for modeling groundwater flow (with MODFLOW of McDonald and Harbough, 1988), was used.

The MODFLOW, a modular three-dimensional finite-difference groundwater flow model, can simulate and predict the hydraulic behavior of groundwater systems. This model uses different iterative solutions to solve the finite-difference equation for groundwater flow. Hydrogeological layers can be simulated as confined, unconfined, or a combination of confined and unconfined. External stresses such as wells, can also be simulated. Boundary conditions include specified head, specific flux, and head-dependent flux. The partial differential equation describing three-dimensional movement of groundwater through porous material can be written as:

$$\frac{\partial}{\partial x} \left(K_x \frac{\partial h}{\partial x} \right) + \frac{\partial}{\partial y} \left(K_y \frac{\partial h}{\partial y} \right) + \frac{\partial}{\partial z} \left(K_z \frac{\partial h}{\partial z} \right) - W = S_s \frac{\partial h}{\partial t}$$

where K_x , K_y , K_z are values of hydraulic conductivity along x , y , and z coordinate axes. W is the volumetric flux per unit volume and represents sources and/or sinks of water. S_s is the specific storage of the porous material, h is the piezometric head, and t is the time.

The MODFLOW has been applied to study groundwater flow pattern under the SEB. Data collected from the field is used to calibrate and validate the model. Subsequently, the sensitivity with reference to SEB depth, width and rain is determined.

DOMAIN DISCRETIZATION

The SEB catchment is considered as 4-hectare command area. The area has been divided into 20 rows and 20 columns with each cell of 10m × 10m dimensions. The SEB is located in the center of the simulation network. The simulation domain of 13m in the vertical perspective is divided into three layers. The top layer is considered unconfined and second layer is considered convertible between unconfined and confined with varying hydraulic conductivity, whereas the third layer is considered confined. The piezometers are placed in the second layer as shown in Figure 5.

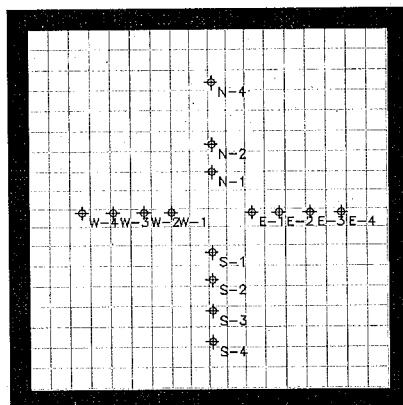

Figure 5 Model Domain

INITIAL AND BOUNDARY CONDITIONS

The initial groundwater levels are taken as per the data collected during the 1st week of August 2000, and are shown in Figure 6. No effect of groundwater recharge and pumping is considered from the catchment vicinity. No flow boundary conditions are considered; and groundwater level at the boundary is taken equal to the initial groundwater conditions.

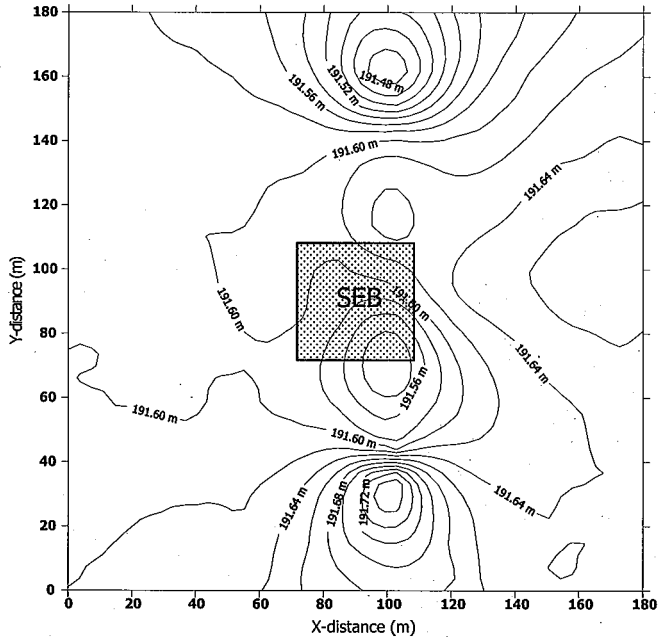

Figure 6 Groundwater levels during the first week of August 2000 (initial conditions).

CALIBRATION AND VERIFICATION

Calibration and verification refers to matching of observed and simulated hydraulic heads. Observed hydraulic heads of all observation wells except N-3 are used to calibrate the model. Calibration was done by using a composite value of hydraulic conductivity under no flow boundary conditions and transient flow in the modeled area. The comparison of the simulated and known heads for observation well N-1 is shown in Figure 7. The figure shows good agreement between the observed and simulated hydraulic heads. Agreement between simulated and measured values was quantified by the root mean square error (RMSE). The RMSE represents how much the simulation overestimates or underestimates the actual field measurements (Sarwar, 2000):

$$RMSE = \left[\frac{\sum_{i=1}^n (M_i - S_i)^2}{n} \right]^{1/2}$$

where M_i and S_i are the measured and simulated values at the day i and n is the number of days of observation.

The RMSE for N-1 was 1.28 cm. The RMSE values for all the other piezometers are given in Table 1. The comparison shows that the discrepancies in the measured and simulated groundwater table depths were small with the $RMSE \leq 3$ except N-4 and S-4, who have root mean square error values of 4.49 and 4.4 respectively.



Figure 7 Calibration of observation well N-1.

Table 1 Root Mean Square Error for each piezometer over the study period.

OW ID	RMSE (cm)	OW ID	RMSE (cm)
E-1	1.06	N-1	1.28
E-2	1.82	N-2	1.18
E-3	2.25	N-4	4.49
E-4	2.37	S-1	3.00
W-1	0.95	S-2	2.66
W-2	0.88	S-3	1.72
W-3	0.84	S-4	4.40
W-4	0.94		

GROUNDWATER FLOW PATTERN

The results of the modeling study show that the gradient starts developing towards SEB after 4 weeks. The complete gradient is developed towards SEB from all sides after nine months (39 weeks), lowering the water table up to 0.94m. It became steeper after 43 weeks, showing a difference of 12.31 cm between the extreme cell of the catchment and the center of SEB. Figure 8 shows the different stages of gradient development towards SEB.

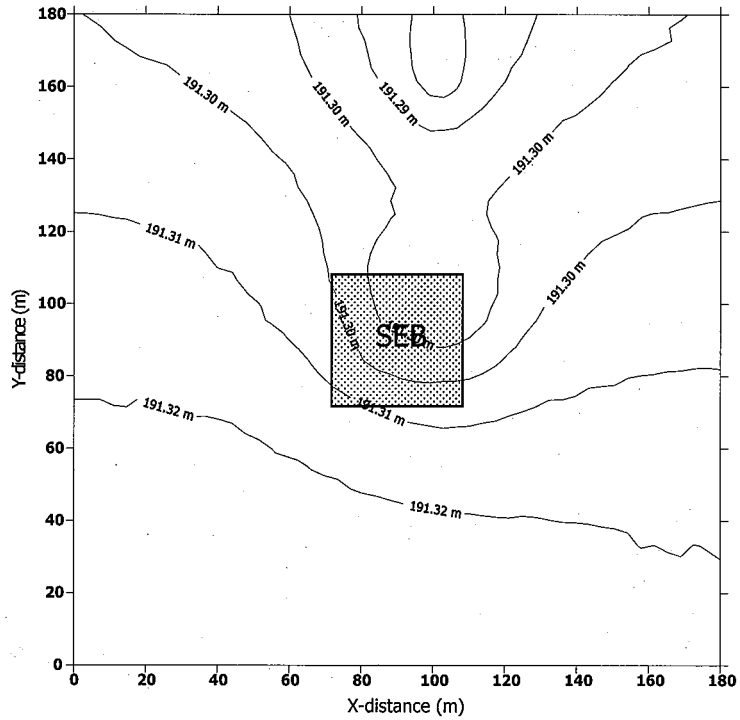

Figure 8a Different stages of gradient development towards SEB (a) after 16 weeks (b) after 42 weeks.

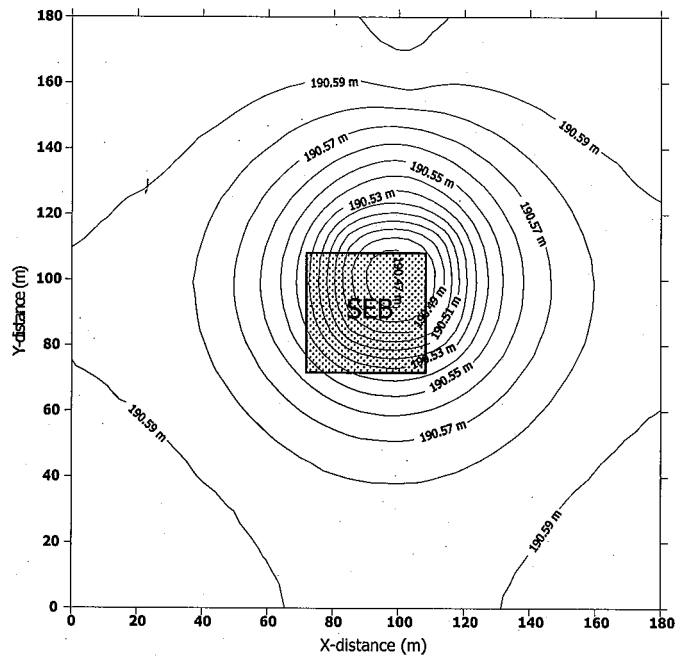

Figure 8b Different stages of gradient development towards SEB (a) after 16 weeks (b) after 42 weeks.

OPTIMIZING THE DESIGN OF SEB

The calibrated model (MODFLOW) was used to optimize the different design parameters of SEB. The sensitivity of the following variables was studied:

- Depth of SEB
- Cross-section of SEB
- Rainfall probability

A total number of 14 runs were executed for simulating different scenarios. Run 1 was executed as the base run. The remaining simulation runs were executed by changing only one parameter in the base run. A summary of runs is given in Table 2.

Table 2 Summary of model runs

Run No.	SEB Depth (%)	SEB Area (%)	Rainfall (%)*
1	100	100	Actual
2	100	50	Actual
3	100	75	Actual
4	100	125	Actual
5	100	150	Actual
6	50	100	Actual
7	75	100	Actual
8	125	100	Actual
9	150	100	Actual
10	100	100	25
11	100	100	50
12	100	100	75
13	100	100	100
14	No SEB		Actual

* Rainfall probability of last 30 years (1970-99) rainfall data of Faisalabad meteorological station

DEPTH OF SEB

Figure 9 shows the relationship between the change in the actual depth of SEB (1.8 m = 100%) and water elevation difference. The water elevation difference shows the gradient towards the center of SEB from the boundary of the catchment. Figure 9 is based on the results of model runs 1 to 5. The data are analysed for two scenarios i.e. dry spell (pre-monsoon) and wet spell (post-monsoon). In pre-monsoon high values of gradient are observed because there is no recharge in the catchment area from surface and water moves towards SEB due to topographic difference. In this case water moves towards SEB and evaporates at higher rate than the bare soil evaporation. Thus, during the dry spell (pre-monsoon) the gradient towards SEB becomes steeper as there is increase in evaporation basin depth. With the decrease in SEB depth water elevation difference also becomes less. But the overall graph trend shows the increase in gradient with the increase in SEB depth. There is apparent change in gradient up to 125% of actual depth, and after this depth there was no noticeable change in the gradient. In post monsoon the water level goes up in all the catchment as well as ponding in the SEB. This may be the reason for non-development of gradient towards SEB.

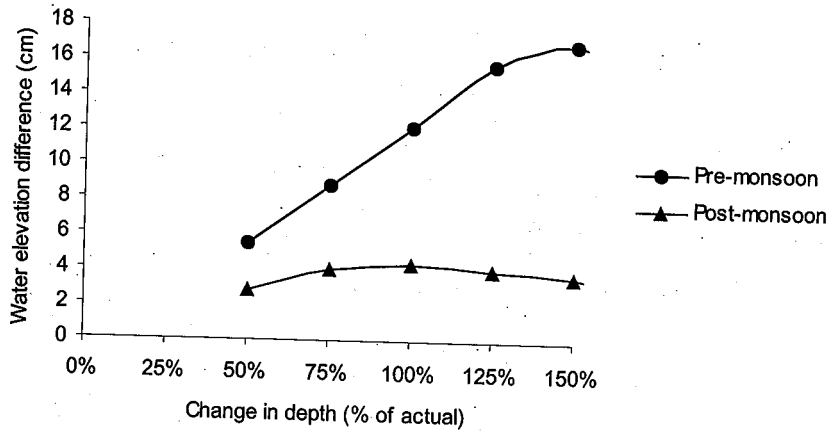

Figure 9: Effect of depth change in gradient development towards SEB.

CROSS-SECTION OF SEB

Figure 10 shows the relationship between the SEB cross-section and resulted changes in water elevation differences. Hundred percent cross-section represents the SEB dimensions as 36.5 × 36.5m. Thus, the cross-section of SEB is changed for different scenario calculations and it is kept in square shape in all the cases. A linear relationship is observed between the SEB cross-sections and resulted gradient (Figure 10). On the average 1.75 cm change in gradient is calculated in pre-monsoon, with 25% change in SEB cross-section. These results are based on the model runs 1, 6, 7, 8 and 9. In post monsoon conditions the trend is same but change is not so apparent. The reason is same as in case of SEB depth.

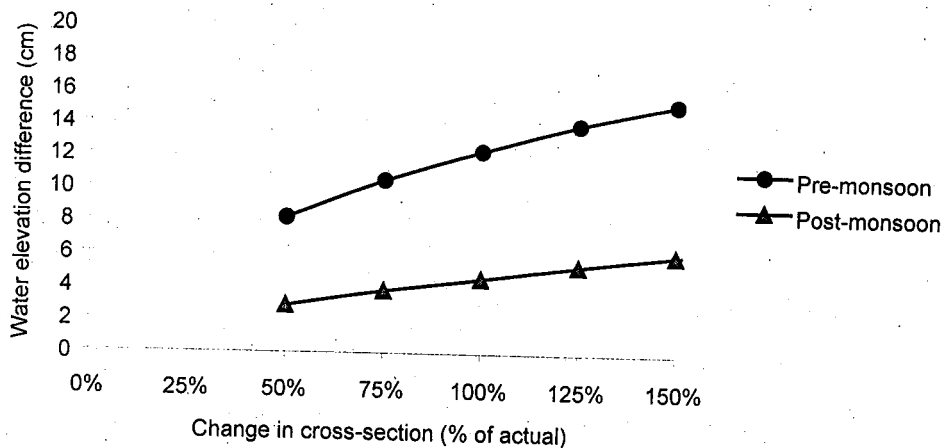

Figure 10: Effect of cross-section change in gradient development towards SEB.

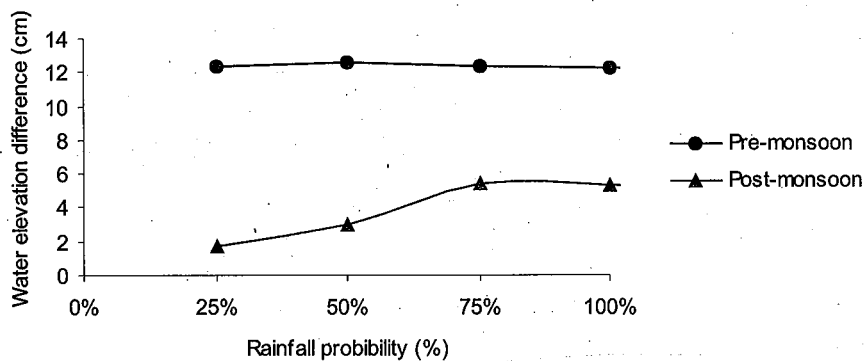

Figure 11: Effect of rainfall probabilities in gradient development towards SEB.

RAINFALL PROBABILITY

Rainfall data of last 30 years (1970-1999) from Faisalabad meteorological station is analysed for this scenario calculation. For this purpose monthly data are sorted out in ascending order. The values available in the first row are said to be 100% (04 mm) probability. The values in seventh, fifteen and twenty-second row are taken as 75% (134 mm), 50% (278 mm) and 25% (475 mm) rainfall probability, respectively. These rainfall probabilities are used as model inputs. Figure 11 is based on the model runs 10, 11, 12 and 13 for these probabilities. No clear impact of rainfall was observed in this special case, under pre-monsoon conditions. Some gradient has been developed towards SEB after monsoon at 75% rainfall probability, which is not so apparent and is comparable with the values of gradient developed after monsoon in case of depth and cross-section scenarios.

From the above discussion it can be concluded that under the existing Hydrogeological conditions, the changes in SEB depth show better impact on gradient development as compared to SEB width. Changes in rainfall have no clear impact on gradient development towards SEB.

CONCLUSIONS

- Following conclusions are drawn from this study:
- Complete gradient is developed towards SEB after nine months.
- Under the existing Hydrogeological conditions, increasing depth of SEB is more effective than increasing width.
- SEB may possibly be more useful in the areas with high horizontal hydraulic conductivity (K_h) and low vertical hydraulic conductivity (K_v), predominantly saline and waterlogged soil conditions.

REFERENCES

Chiang, Weh-Hsing and W. Kinzelbach, 1996. PMWIN: Processing MODFLOW for WindowsTM – A simulation system for modeling groundwater flow and pollution. Distributed by C Vision Pvt Ltd. 185 Elizabeth St Suite 320, Sydney NSW 2000, Australia.

- McDonald, M.C., and A.W. Harbough, 1988. MODFLOW: A modular three-dimensional finite difference groundwater flow model. U.S. Geological Survey, Open-File Report 83-875, Chapter A1.
- Mirbahar, M.B. and A.M. Sipraw. 2000. On-farm tile drainage with farmers' participation: Past experience and future strategies. Proceedings of National Seminar on Drainage in Pakistan held at Mehran University of Engineering & Technology, Jamshoro, Pakistan. August 16-18, 2000.
- Sarwar, A. 2000. A transient model approach to improve on-farm irrigation and drainage in semi-arid zones. Ph.D. Thesis. Wageningen University and Research Center, Wageningen, The Netherlands.
- Singh, J., E.W. Christen. 2001. Evaporation basins: Opportunities for cost minimisation in siting, design and construction. *Irrigation and Drainage*, 50(1):19-29.

Modeling the Effects of Conjunctive Water Management on Secondary Salinization

Asad Sarwar Qureshi¹ and Ilyas Masih²

ABSTRACT

The shortage of good quality water for irrigation is becoming an important issue in the arid and semi-arid zones. For this reason, the availability of water resources of marginal quality such as saline groundwater has become an important consideration. Saline groundwater is used for irrigation both in isolation and in conjunction with good quality canal water. Due to lack of proper knowledge of management of different quality waters for irrigation, large tracts of irrigated lands are already salinized or under threat. To avoid the process of secondary salinization of soil, irrigation with saline water requires a comprehensive analysis to ensure long-term sustainability of irrigated agriculture. This paper presents the results of a modeling study carried out to evaluate the long-term effects of different quality irrigation water on root zone salinity.

Keywords: Groundwater quality, secondary salinization, modeling, irrigation water quality, conjunctive water use.

INTRODUCTION

In the Indus Basin, inadequacy and unreliability of surface irrigation supplies have turned the farmers more and more to the use of groundwater without the full awareness of the hazard represented by its quality. The massive development of groundwater from the Indus Basin aquifer started about 30 years ago. At present, total groundwater contribution is estimated as approximately 40-50 % of the total water available at the farm gate. This source is exploited by the use of 20,000 public and over 500,000 private tubewells. About 70 % of the private tubewells are located in the canal command areas where groundwater is used in conjunction with canal water, the rest provides irrigation based on groundwater alone. The quality of groundwater is highly variable ranging from fresh ($EC \leq 1.0$ dS/m) to extremely saline ($EC \geq 3.0$ dS/m) and is a main factor in the salinity development in the root zone.

The exploitation of groundwater provides an opportunity for the farmers of these areas to supplement their irrigation requirements and cope with the vagaries of the surface supplies. However, the uncontrolled and unregulated use of groundwater is replete with serious consequences as it is aggravating the problem of secondary salinization. As a result, salt affected soils have become an important ecological entity in the Indus Basin of Pakistan. It is estimated that nearly six million hectares area is already affected with this menace, of which about half is in irrigated areas (WAPDA, 1989). Out of this estimated area, about two million hectare are abandoned due to severe

¹ Acting Regional Director, IWMI Regional Office, Lahore, Pakistan

² Junior Hydrologist, IWMI Regional Office, Lahore, Pakistan

salinity (Wolter & Bhutta, 1997). The extent keeps on changing due to dynamic nature of the problem.

Over the past three decades, numerous efforts have been made to solve the problem of soil salinization and improve water use efficiency at farm level. In spite of huge investments, the success has been limited. The reasons are that the research conducted to advice farmers on appropriate practices of using different quality irrigation water was generally based on field scale experiments and was not tested for their long-term consequences on crop production and environmental degradation. The results were, therefore, regarded as local and short-term solutions and could not get the attention of the farming community. An integrated water management approach could be useful to manage available surface and subsurface water resources with respect to quantity and quality in view of crop production and soil salinization.

Dynamic simulation models that can calculate soil water and solute transport originating from all water resources in combination with crop growth, are best tools to provide a rapid, flexible and relatively inexpensive means of estimating the effects of various irrigation management practices on crop production under a variety of climatic and physical conditions (Bradford and Latey, 1992; Teixeira et al, 1995). The main objective of this study was to evaluate the long-term effects of different quality irrigation water on soil salinity for the conditions prevailing in the wheat-cotton agro-climatic zone of Rechna Doab, of Punjab, Pakistan. For this purpose, soil water flow model SWAP (Feddes et al, 1978; Belmans et al, 1983) calibrated by Sarwar et al. (2000) for Rechna Doab was used.

MODEL DESCRIPTION

SWAP (Soil, Water, Atmosphere and Plant) simulates vertical transport of water, solutes and heat in the unsaturated/saturated soils. The program is designed to simulate the transport processes at field scale level as well as during entire growing seasons (Van Dam and Feddes, 2000; Kroes et al., 1999). SWAP employs the Richards' equation for the soilwater movement in the soil matrix, subject to specified initial and boundary conditions and with known relations between soil water content, soilwater pressure head and unsaturated hydraulic conductivity. Rootwater extraction at various depths in the root zone is calculated from potential transpiration, root length density and possible reductions due to wet, dry, or saline conditions. Solute transport is simulated using governing equations of convection, diffusion, and dispersion, non-linear adsorption, first order decomposition and root uptakes of solutes. Different processes simulated by SWAP model are shown in Figure 1.

Crop growth is simulated by using a detailed model WOFOST, which explains crop growth on the basis of processes, such as rate of phenological development, interception of global radiation, CO₂ assimilation, biomass accumulation of leaves, stems, storage organs and roots, leaf decay and root extension. The assimilation rate is affected by water and/or salinity stress in the root zone. SWAP can use simple crop model, when sufficient data is not available or crop growth simulation is not needed. In this case, leaf area index, crop height and rooting depth as function of development stage are prescribed by the user. Basic daily meteorological data are used to calculate daily, potential evapotranspiration according to Penman-Monteith.

Irrigation applications (irrigation timing, depth and water quality) can be prescribed at fixed times or user may choose various timing and depth criteria in order to optimize irrigation application. The scheduling options allow the evaluation of impact of different irrigation scenarios on crop growth

and salinity development. The SWAP model can also be used to evaluate drainage design and surface water systems.

Figure 1: Processes incorporated in the SWAP model

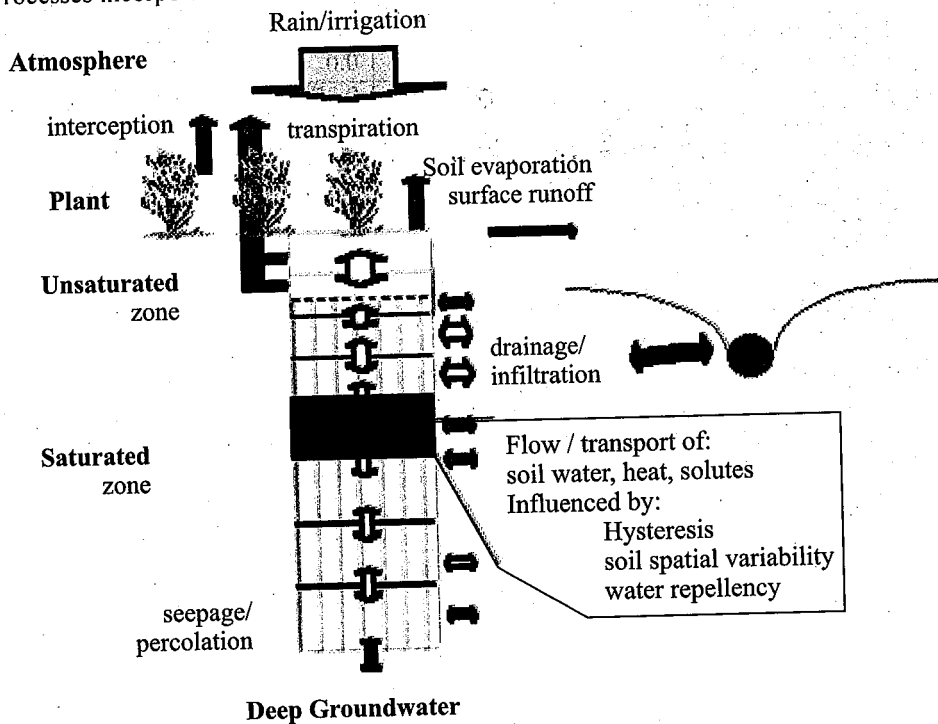

Model Calibration and Application

SWAP model was calibrated for the lower Rechna Doab. The area is part of an alluvial plain between the rivers Ravi and Chenab (31°N and 73°E). The climate is continental, sub-tropical and characterized as semi-arid with large seasonal fluctuations in temperature and rainfall. The average annual rainfall is about 350 mm and the class A Pan evaporation is about 2000 mm. The soils of the area are mainly loam to silt-loam underlain by highly conductive aquifer of loamy sand to sandy loam. The model was calibrated for the field conditions on the bases of actual soil, crop, climate and irrigation data (Sarwar, 2000). Wheat-cotton rotation was used for the simulations. Different soil and crop parameters used as input for SWAP calibration are given in Table 1 & 2. The validated model was used to simulate the scenarios to investigate the impact of different quality groundwater either alone or in conjunction with good quality canal water on soil salinity build up.

Table 1: Input parameters used in the SWAP model. The h_1 to h_4 values refer to the sink term theory of Feddes et al. (1978).

Input parameters	Wheat	Cotton
Boesten parameter, β (cm ^{1/2})	0.63	0.63
k_c -value for full crop cover	1.15	1.15
Maximum rooting depth (cm)	110	160
Limiting pressure heads (cm)	$h_1 = -0.1; h_2 = -1.0;$ $h_3 = -500; h_3' = -900;$ $h_4 = -16000$	$h_1 = -0.1; h_2 = -1.0;$ $h_3 = -500; h_3' = -900;$ $h_4 = -16000$

Table 2: Calibrated Van Genuchten-Mualem (VGM) parameters used to describe soil hydraulic properties in the SWAP model.

Parameters	Layer 1	Layer 2	Layer 3
Depth of Layer (cm)	0-30	30-280	>280
Soil Texture	loam	Silt loam	loamy sand
Residual moisture content θ_{res}	0.0	0.0	0.028
Sat. moisture content θ_{sat}	0.384	0.509	0.40
Sat. hyd. cond. K_{sat} (cm d ⁻¹)	60	40	72
Shape parameter α (cm ⁻¹)	0.0085	0.0090	0.014
Shape parameter n (-)	1.35	1.45	2.663
Shape parameter λ (-)	1.0	1.0	0.5

SCENARIOS STUDIED

In Rechna Doab area, groundwater quality varies from North to South (Figure1). In the upper part of the Doab, groundwater is relatively fresh (EC < 1.0 dS/m) and it keeps on deteriorating as we go to the downstream end of Rechna Doab. In middle, there are several pockets where groundwater quality is marginal (EC = 1.5 – 2.7 dS/m) and in lower part of the Doab groundwater is highly saline (EC > 2.7 dS/m). This ranking of groundwater quality is based on the criteria developed by WAPDA (Latif and Lone, 1992) (Table 3).

Figure 1: Groundwater quality in Rechna Doab.

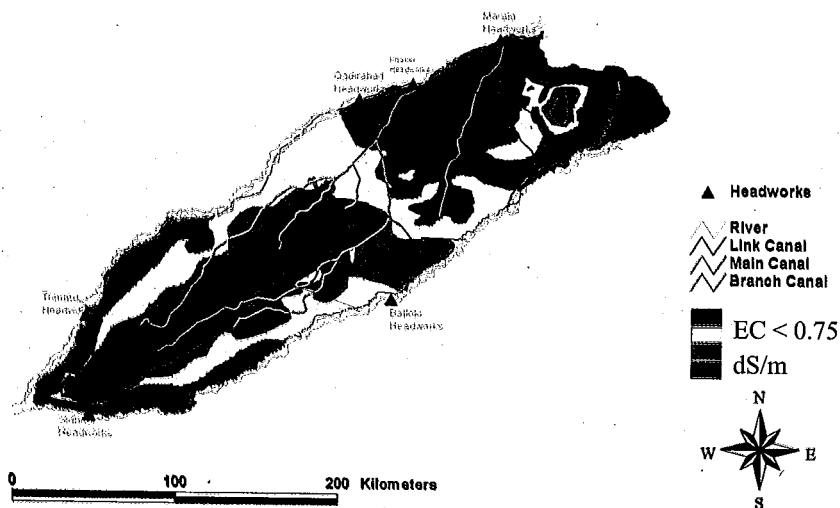

Table 3: Water quality standard for irrigation based on electrical conductivity.

Category	EC (dS/m)
Fresh	< 1.5
Marginal	1.5 – 2.7
Hazardous	> 2.7

In order to develop conjunctive water use strategies for the Rechna Doab, 12 different scenarios considering three groundwater qualities and 3 mixing ratios of surface water (EC = 0.3 dS/m) and groundwater were examined (Table 4).

The effect of these water management scenarios was evaluated on salinity development in the root zone.

Table 4: Scenarios studied using different quality groundwater with combinations of canal water.

Ground-water Quality	Combination 1			Combination 2			Combination 3			Combination 4		
	GW (%)	CW (%)	EC (dS/m)	GW (%)	CW (%)	EC (dS/m)	GW (%)	CW (%)	EC (dS/m)	GW (%)	CW (%)	EC (dS/m)
Fresh	100	0	1.0	80	20	0.86	50	50	0.65	20	80	0.44
Marginal	100	0	1.5	80	20	1.26	50	50	0.90	20	80	0.54
Saline	100	0	3.0	80	20	2.46	50	50	1.65	20	80	0.84

RESULTS AND DISCUSSIONS

Figure 2 shows the salinity development in the root zone when fresh groundwater is used for irrigation in different ratios with canal water. The EC_e values represent the average root zone salinity calculated at 1.0 m deep root zone at the end of each simulation year. Irrigation with fresh groundwater alone does not guarantee the long-term sustainability as the year with below average precipitation enhances soil salinization in the root zone immediately, which also affects the water uptake by the roots (less crop transpiration). However, mixing fresh groundwater with 20 % canal water will keep the root zone salinity below the threshold value of 4 dS/m, although a slightly increasing trend may be witnessed. The value of 4.0 dS/m is usually considered for non-saline soils in Pakistan (Mulk, 1993).

Figure 3 further explains the process of profile salinity built up in the root zone. Irrigation with fresh groundwater alone accumulates salts in shallow depths (i.e., 90 – 150 cm). During the dry years leaching of salts due to monsoon rains become low. Increased soil temperatures forced the salts to move in the upper layers due to capillary action. This phenomenon is much more strong in the areas where watertables are shallow. Mixing fresh groundwater with canal water will keep the salts well below the root zone making it almost impossible to come at the surface even in dry seasons.

Figure 2: Long-term impact of irrigation with fresh groundwater (EC = 1.0 dS/m) on soil salinity

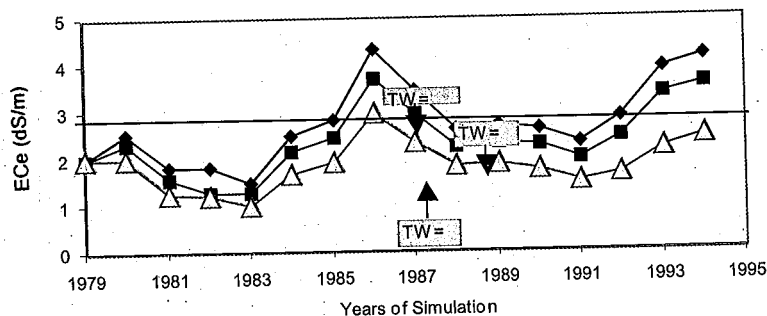
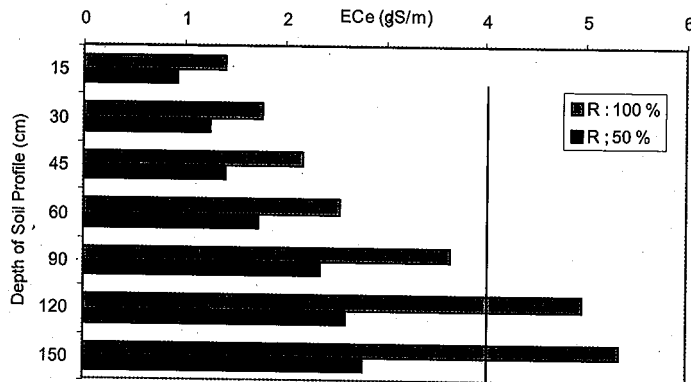

Figure 3: Soil profile salinity with depth after 15 years of simulations, with fresh groundwater irrigation



In the marginal groundwater areas, long-term sustainability can only be achieved by equitable mixing of canal water (Figure 4). By applying marginal groundwater for irrigation alone, the root zone salinity increases sharply in the first 5-6 years and crosses the threshold value of 4 dS/m (Figure 4). Then this salinization process reaches to certain equilibrium with small variation in the salt storage over the years, which can be ascribed to difference in annual precipitation. Figure 5 shows the distribution of salts in the root zone when marginal quality groundwater is used for irrigation alone or in different proportions with canal water. The graph shows that ideally more canal water should be mixed to keep the salts well below the root zone depth. However under water shortage environment 1:1 mixing ratio will at least be required for keeping root zone free of undesirable salt accumulation.

Figure 4: Long-term impact of irrigation with marginal quality groundwater (EC = 1.5 dS/m) on soil salinity

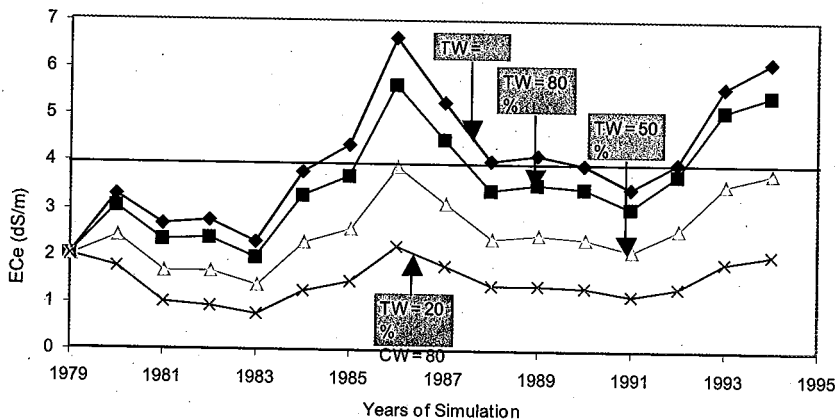
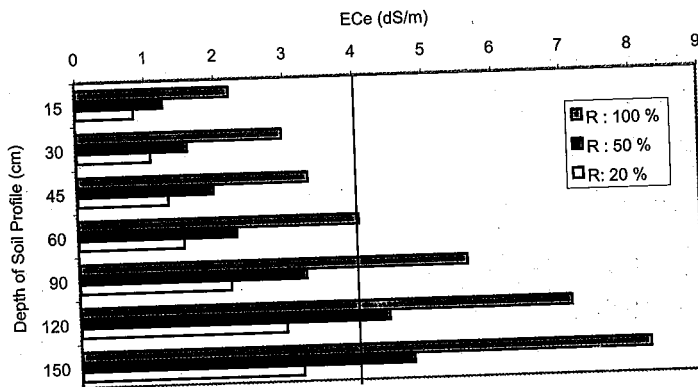

Figure 5: Soil profile salinity with depth, after 15 years of simulations, with marginal groundwater irrigation



The combined analysis of Figures 6 & 7 shows that irrigations with saline water will be a complete disaster. The only scenario, which is slightly sustainable, is that of 80% of canal water mixed with the saline groundwater. Mixing canal water with ratios less than that will not help and lands will go out of production due to salinity in 2-3 years time. Therefore for these areas, other options like growing more salt tolerant crops, eucalyptus or phreophyles should be adopted.

Figure 6: Long Term Impact of Irrigation with Saline Groundwater (EC = 3.0 dS/m) on Soil Salinity

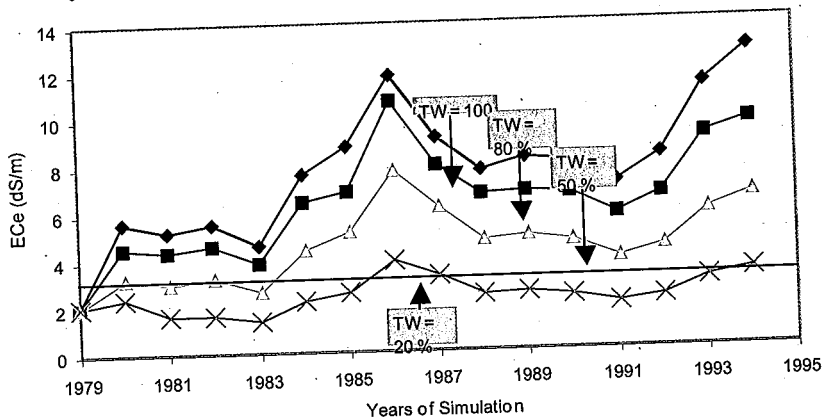
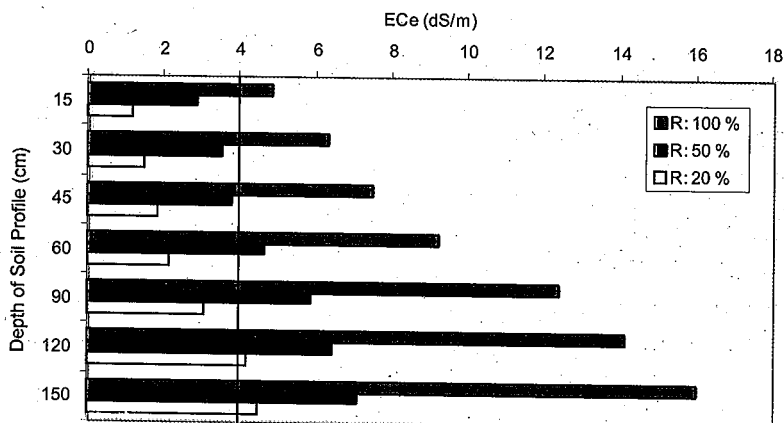

Figure 7: Soil profile salinity status with depth after 15 years of simulations, with saline groundwater irrigation



CONCLUSION

Simulation models such as SWAP are efficient and strong tools to understand and analyze the dynamics of soil salinity in the long run, as influenced by conjunctive use of groundwater with canal water. The following specific conclusions can be drawn:

- In fresh groundwater areas ($EC = 1.0$ dS/m), the use of groundwater alone for irrigation will build up salinity in the root zone. Occasional leaching will be required for long-term sustainability.
- In marginal groundwater areas ($EC = 1.5$ dS/m), mixing groundwater and canal water in 1:1 ratio will keep the soil salinity within acceptable limits, however, special leaching would be needed in relatively dry years.
- Irrigation with saline groundwater ($EC = 3.0$ uS/cm) will be a complete disaster. Mixing this groundwater with canal water will not help in reducing the danger of soil salinization.
- Farmers' present irrigation practices of applying more frequent irrigations with saline water do not help in getting away salts from root zone and this management scenario is not sustainable.

REFERENCES

- Belmans, C., J.G. Wesseling and R.A. Feddes., 1983. Simulation of the water balance of a cropped soil: SWATRE. *J. Hydrol.* 63:217-286.
- Bradford, S. and J. Letey, 1992. Simulated effects of water table and irrigation scheduling as factors in cotton production. *Irrigation Science*, Vol. 13: 101-107.
- Feddes, R.A., P.J. Kowalik, and H. Zaradny, 1978. Simulation of water use and crop yield. *Simulation Monogr*, PUDOC, Wageningen, 188 pp.
- Kroes, J.G., J.C. van Dam, J. Huygen, and R.W. Vervoort, 1999. User's Guide of SWAP version 2.0. Simulation of water flow, solute transport and plant growth in the Soil-Water-Atmosphere-Plant

environment. Technical Document 53, DLO-Winand Staring Centre, Wageningen, Report 81, Department of Water Resources, Wageningen Agricultural University, the Netherlands.

Latif M and Lone M. I. 1992. Modeling salt distribution and assessing water quality parameters. Centre of Excellence in Water Resources Engineering, U.E.T., Lahore, Pakistan. CEWRE/Publication/85.

Mulk, S., 1993. Water Resources of Pakistan. Report for World bank, Washington, USA.

Sarwar, A. and W.G.M. Bastiaanssen, TH.M. Boers and J.C. Van Dam, 2000. Evaluating drainage design parameters for fourth drainage project, Pakistan by using SWAP model: Part I – Calibration. Journal of Irrigation and Drainage Systems 14 : 257-280.

Teixeira, J.L., R.M. Fernando and L.S. Pereira, 1995. Irrigation scheduling alternatives for limited water supply and drought. ICID Journal, Vol. 44, No. 2:73-88.

Van Dam, J.C. and R.A.Feddes, 2000. Numerical simulation of infiltration, evaporation and shallow groundwater levels with the Richards' equation. J. Hydro. (in press).

Water and Power Development Authority (WAPDA), 1989. PC-II performa for monitoring Salinity Control and Reclamation Projects, SCARPs for the period 1989-93. SMO Publication No. 100. Lahore, Pakistan. 60 pp.

Wolters, W. and M.N. Bhutta, 1997. Need for integrated irrigation and drainage management, example of Pakistan. Proceedings of the ILRI symposium, Towards Integrated Irrigation and Drainage Management, Wageningen, The Netherlands.

Part III

Technical Aspects of Conjunctive Water Management

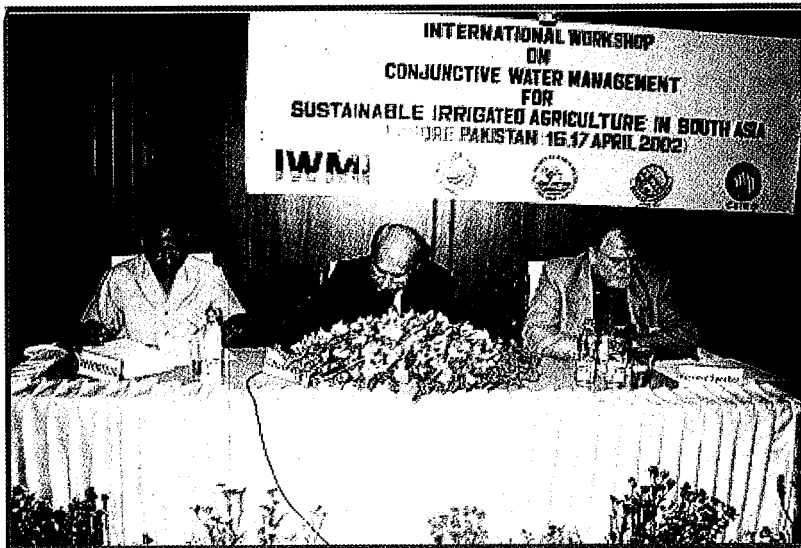

Mr. Mirza Hamid Hassan, (center), Chairman of the Session
Prof. Wolfgang Flugal, (right), Keynote Speaker
Dr. Mehboob Alam, (left), Rapporteur

Conjunctive Use of Water Resources for Integrated Water Resources Management (IWRM) – Integrating Spatial Analysis and Innovative Geomatics Techniques

Wolfgang-Albert Flügel¹

INTRODUCTION

Conjunctive use of water resources may be defined as the sustainable management of different water resources, which vary in availability, quantity and quality over time and space to optimize productivity and minimize the risk of failure.

A balanced management decision system demand the following prerequisites:

1. Sufficient information must be available to the manager about the quality, quantity and availability of the water resources in question. The probability of availability of these resources must be known with a certain level of significance to ensure the reliability of the concept.
3. Quantity and quality of the water resources must be predictable and the dynamic process generating their variability of both must be understood.
4. The processes controlling the regeneration of the respective water resource must be appreciated to avoid overexploitation.
5. The water resource must be part of an integrated systems balancing approach.

The main objective of the integrated approach is to promote the management of conjunctive use of water resources as a vital component of a holistic systems approach towards *integrated water resources management (IWRM)* within a *dynamic human framework*.

REQUIRED METHODOLOGY AND TOOLSET:

In order to achieve the integrated objectives, the required methodology and toolsets are:

- A user-friendly integrated geo-relational database management system (DBMS) comprising data from different sources to support the information requirement of the holistic systems approach. A distributed regional hydrological model using the DBMS as an information base to simulate the “real world” water resources balance dynamics integrating “state-of-the-art” Geomatic techniques. A distribution model simulating “what-if?” scenarios to use the different water resources most efficiently.

¹ Principal Researcher, Hydrology, IWMI, Colombo, Sri Lanka

- A user-friendly decision support system (DSS) integrating the various components mentioned above and evaluating various “real world” management scenarios. The following figures explain how integrated and innovative geomatics techniques can be used in conjunctive use

Multi-Tier structure of IRIBAS

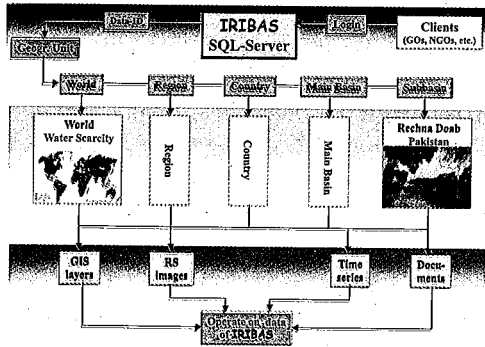

The Figure indicating a multi-tier structure of integrated river basin management showing the data bases, geographical integrity and utility of integrated river basin management.

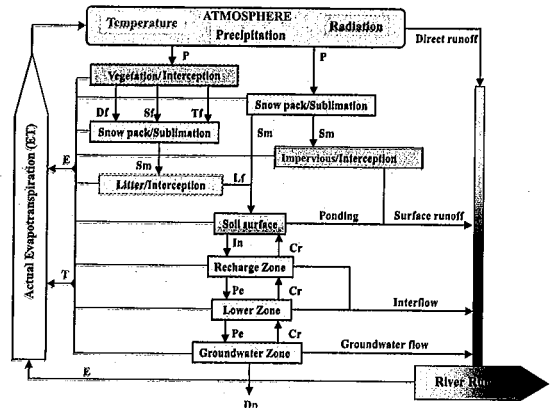

The Figure explains the conceptual design and storage oriented cascading structure of the regional catchment models. These models could be used to study the hydrological dynamics of river basins.

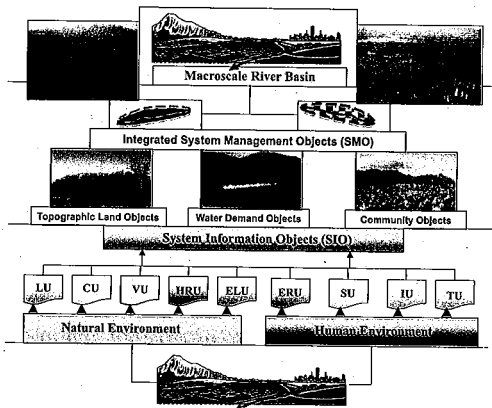

The Figure depicts the distribution of river basin using generic response units (RU) concept, which represents the basin heterogeneity in terms of its natural and human environment.

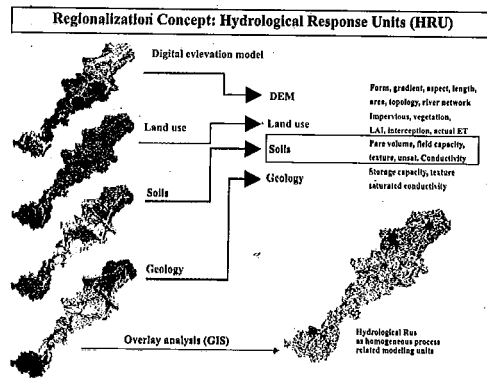

The Figure shows the regionalization concept of hydrological response units using remote sensing (RS) and GIS integration

of water resources for integrated water resources management

The following Figures represents the schematics of the topological connectivity of HRU-subareas for routing water, solute and erosion material to the corresponding adjacent river segment

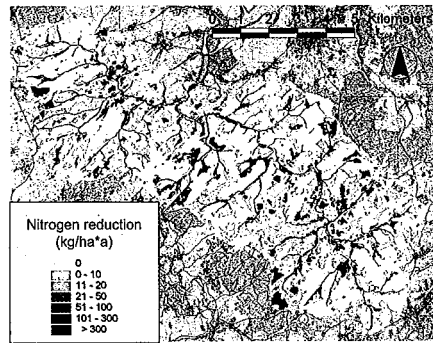
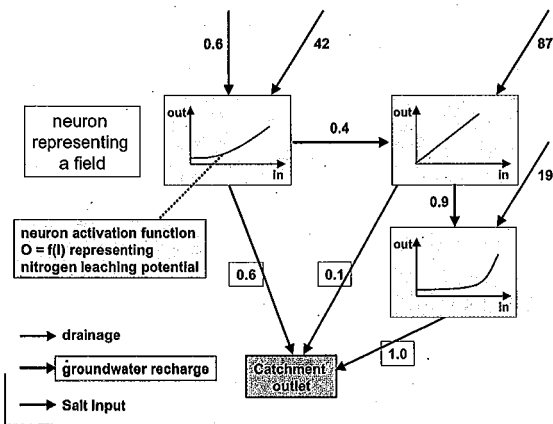
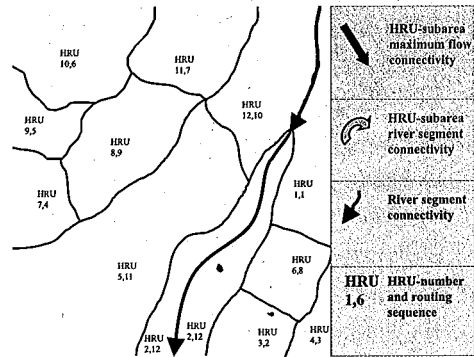
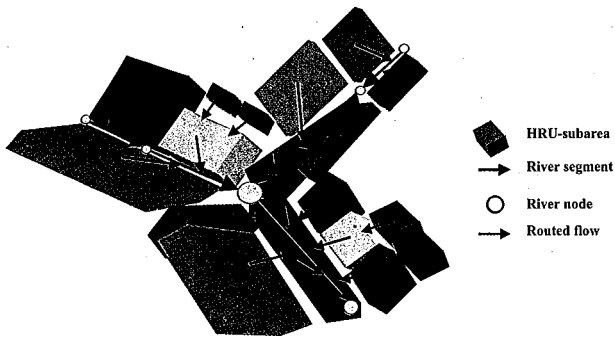

The Figure given below indicates the conceptual model of water resources response units (WRRUs) representing the resource routing and distribution within a command area.

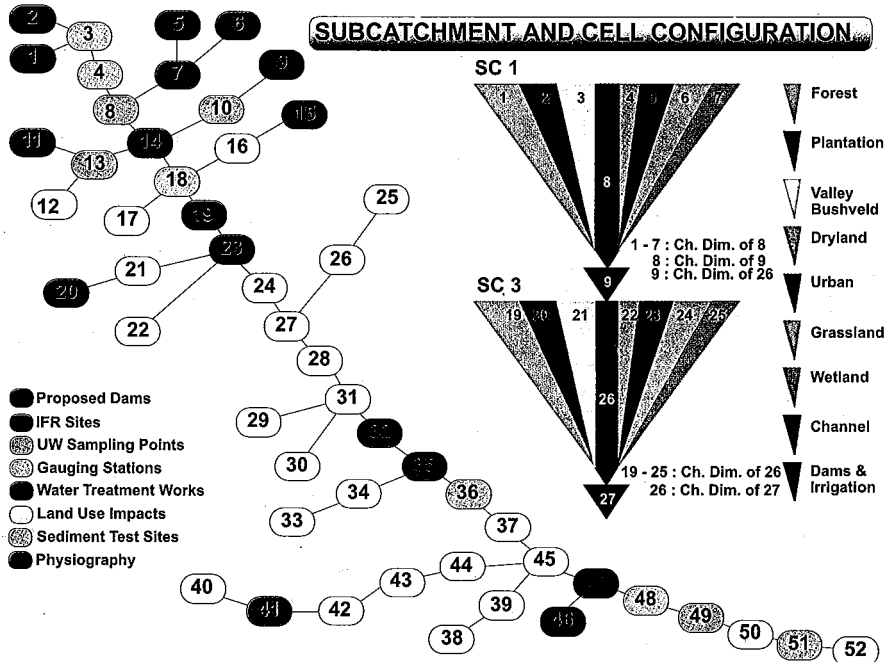

Water allocation model (WAM) using GIS network analysis: Elevating various “what if” scenarios of water allocation in a command area.

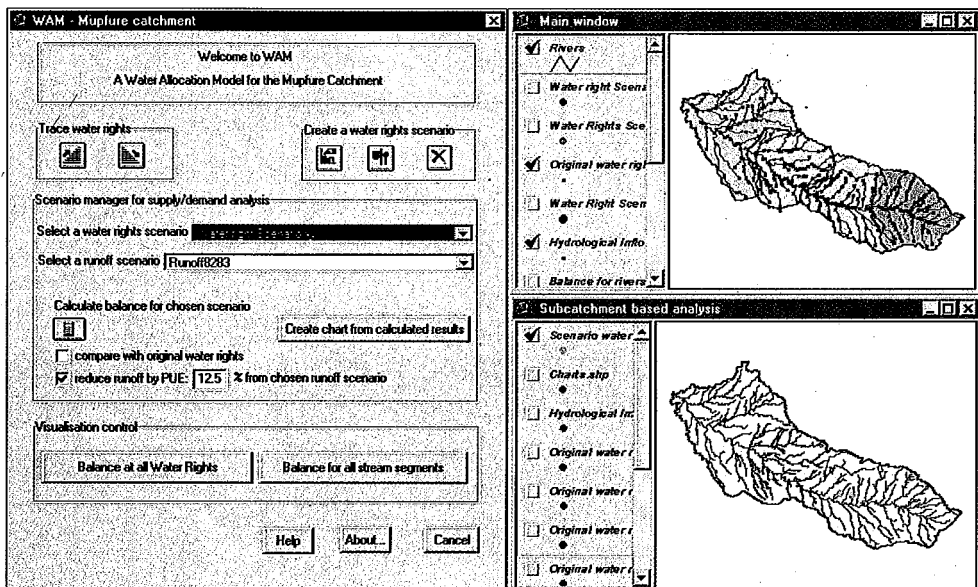

CONCLUSION AND FUTURE RESEARCH

A primary task for conjunctive water use must be the establishment of a user friendly DBMS which provides the required information to users of the concept.

Regional hydrological modeling must be carried out to analyse the recharge and balance of the respective water resource as a base of a sustainable IWRM on a basin level.

A DSS must be available to support managers and decision makers integrating the DBMS and the systems modeling for the design of "real world" management scenarios for decision support.

The concept of conjunctive use of water resources must be disseminated and implemented as a common management approach and a strategy to sustain the use and availability of the respective water resource.

Conjunctive use of water resources requires a sophisticated and collaborative approach and this cannot work in an isolated and overburdened environment.

Soil Salinity / Sodicty and Ground Water Quality Changes in Relation to Rainfall and Reclamation Activities

Nazir Hussain¹, Fakhar Mujeeb¹, Ghulam Sarwar¹, Ghulam Hassan¹ and M. Kaleem Ullah²

ABSTRACT

The agronomic, chemical and engineering approaches for reclamation of saline sodic soil were investigated at the research farm of Soil Salinity Research Institute, Pindi Bhattian, Pakistan. A catchment area of nine acres was selected, sampled and analyzed for salinity parameters. A sub-surface evaporative basin (SEB) of 0.3 acre size having depth of six feet was dug in the center of the catchment area. Piezometers network on all the directions and in the SEB were installed to record the water levels weekly. The groundwater quality was monitored quarterly. The soil analysis of catchment area was conducted pre and post-monsoon. Rain and pan evaporation data were also recorded.

It was observed that during the dry spell the surface accumulation of salts increased many times. The intensive rains of monsoon season reverted the cycle and salts started leaching into lower depths. However, the quantity of total precipitation in the two years was not ample to sequester the salts into SEB because the groundwater level was consistently going downwards. Hence, in spite of deep ploughing and cultivation of the catchment area, the land reclamation was nominal. But when chemical amendments were applied, mixed into the soil, irrigation water provided and subsequent rice crop was grown in selected two acres adjacent to the SEB, the salts moved into the SEB. The groundwater of SEB Piezometers installed in the directions of cropping area (East and South) was having significantly higher EC, pH, SAR, CO_3^{-2} HCO_3^{-2} and Na^{+1} as compared to Northern and Western sides without crops. Each irrigation attempt caused a substantial movement of salt into the SEB. The SEB bed was having EC, pH and SAR of 6.33 dSm^{-1} , 9.98 and 150.6 respectively. There have been no conspicuous changes in groundwater quality in two years except through soil reclamation and crop growing activities, which resulted in appreciable increase of EC, SAR and RSC of it.

INTRODUCTION

There are different approaches for reclamation of salt-affected soils. The prominent ones are chemical, biological, hydro-technical, physical and engineering approaches. The synergistic approach is the combination of any two or more approaches. (Hussain *et al.* 1990). In the conventional approach, the salts are not removed from the hydro-cycle. Recently, it has been emphasized by the scientists that such ways and measures should be devised in which the salts are

¹ Senior Researchers, Soil Salinity Research Institute (SSRI), Pindi Bhattian, Pakistan

² Junior Civil Engineer, International Water Management Institute (IWMI), Lahore, Pakistan

removed from the cycle. Subsurface evaporation basin (SEB) is the technique which has been proposed to find answer to the current question. Under this technique, a bigger sized basin is excavated at a low-lying point in the topographical configuration of the affected area. The salts dissolved in the rainy water or irrigation water move ultimately to this basin. Resultantly, the salts are removed from the hydro-cycle and accumulate in the basin. The catchment area is kept clean and cultivated so as to harvest the maximum benefits of the rainfall, especially in the monsoon season. The ripping (deep ploughing) has been reported to ease the leaching of salts into the profile (Hussain et al. 2000).

In arid and semi-arid regions of the world, salinity / sodicity is a permanent problem inherited due to climatic conditions (high temperature and low rainfall). The net movement of water is upwards. The salts dissolved in the water accumulate slowly and gradually in the surface of the soil as the water evaporates. Hence, the soil salinity / sodicity pattern, changes with variations in the frequency and intensity of rainfall as well as temperature regime. Mostly, salts accumulate on the surface in the winter and dry season and wash down into the lower profile with rainfall. The alternating dry spell and intensive monsoon rainfalls in some of the years are very common. Soil salinity increases through capillary rise from the saline water table and from concentration of irrigation water in the field. Desalinization may occur through vertical percolation of salts and surface drainage. Changes in salinity with time are usually rapid depending upon management practices or abandoning the land (Cauppens et al. 1997). The reclamation activities in which water is applied in excess to the salt affected soils also favor leaching of salts downwards.

To find a scientific answer to the above-mentioned questions, present investigations were conducted. The variations in soil salinity / sodicity with respect to time span and climatic conditions (rainfall and evaporation) as well as reclamation activities were monitored. The resultant changes in the quality of water were also assessed. The probability of salt mobility towards the SEB was evaluated as well. Hence, the current burning issues were included in this research study.

MATERIALS AND METHODS

A soil reclamation experiment employing synergistic approach combining agronomic, biological, chemical and engineering measures was conducted at the research farm of Soil Salinity Research Institute, (SSRI) Pindi Bhattian, Pakistan (Figure 1).

These investigations were conducted by collaborative efforts of SSRI, International Water Management Institute (IWMI), Lahore, Pakistan Council for Research in Water Resources (PCRWR) and CSIRO, Australia under the project, "Conjunctive Water Management for Sustainable Agriculture in South Asia". A catchment area of nine acres, highly saline sodic, barren and bald for last three decades was selected. A topographic and lithological survey was undertaken to locate a low-lying area within the catchment area. A six feet deep basin of 0.33 acre was excavated at the located point in May 2000.

A network of 18 observation wells (Piezometers) was installed in all the four directions to monitor the changes in groundwater level and quality in relation to climatic conditions and agricultural practices. A schematic lay out has been indicated in Figure 2. The groundwater level was recorded weekly and its quality was assessed quarterly. Rainfall data was noticed at the event of occurrence while pan evaporation was observed daily.

Figure 1: Location of Study Site.

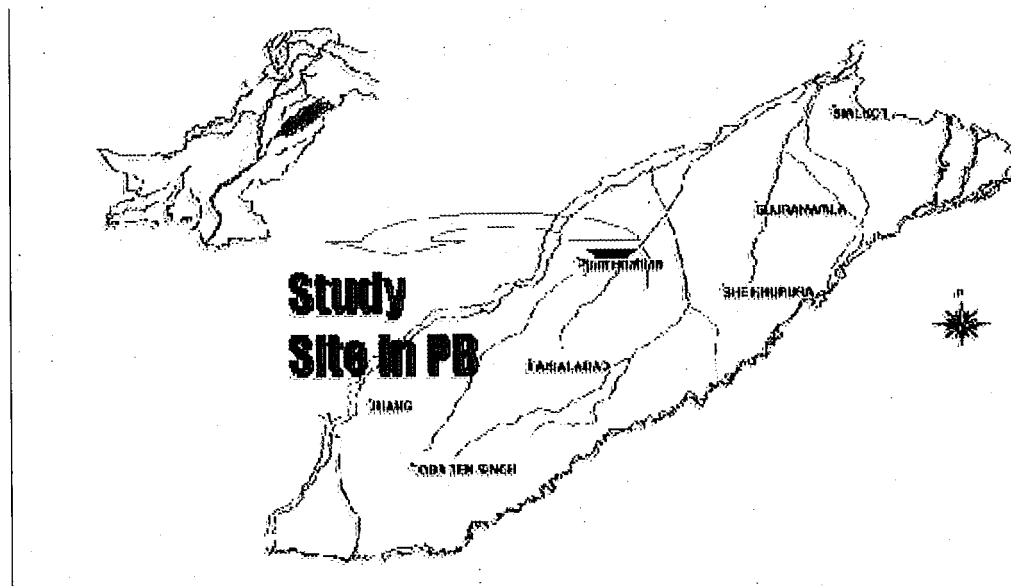
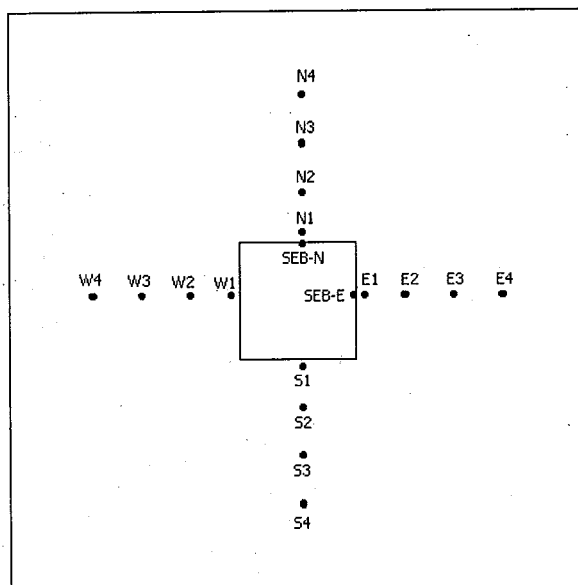

Figure 2: Schematic Lay Out of Piezometers in the Surrounding Area of SEB.



The detailed soil analysis of catchment area was conducted pre and post-monsoon. Composite soil samples were obtained up to the depth of 165 cm for analysis. The deep ploughing and disking operations in the catchment area were also completed pre and post-monsoon. Agricultural practices being carried out in the catchment and vicinity areas were recorded.

In the second year, 2 acres area adjoining to SEB on Eastern and Southern sides were selected for the growing of crops after reclaiming soil. Soil samples were obtained and gypsum requirement was

determined (Richard, 1954). After ploughing these fields, gypsum @ 100 % of the requirement was applied and mixed into the 15-cm surface soil. Subsequent leaching for 10 days was provided to sequester the salts into SEB. Rice crop was grown subsequently. Soil samples were obtained at the time of crop harvesting. Water samples of piezometers installed in the SEB were collected 3 times during irrigation of the crops for quality assessment. The climatic data was related to the variations in the soil characteristics and groundwater quality.

RESULTS AND DISCUSSIONS

Results of the data (2000-2001) on rainfall, evaporation, soil salinity / sodicity status and quality of ground water are discussed as under:

Rainfall

It was observed that monsoon season 2000 did not cause significant rainfall because a total of 140 mm (Figure 3) were received with four events above 20 mm and only one event above 10 mm. The period from September to December, 2000 and January to May 2001 was extremely dry except for only one event of 8 mm rainfall in May, 2001.

Figure 3: Seasonal Fluctuation of Rainfall.

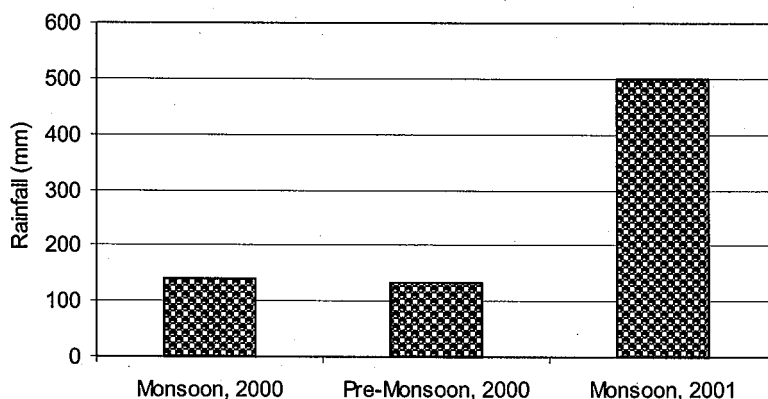

The dry spell continued up to first week of June 2001. The monsoon season started earlier in the year 2001 when rainfall of 20 mm was received in the second week of June, 2001. This season proved fruitful and a total 499 mm rainfall was conceived during the period of June to September. This period was followed by a consistent dry spell up to December 2001 and not a single mm of rainfall was received.

Pan Evaporation

The pan evaporation data indicated very wide variable pattern during various months of the year (Figure 4). As low as 1 mm/day pan evaporation was recorded in the month of January, while maximum magnitude of this parameter was noticed in the month of May with an average value of 9.7 mm/day. The months of December, January and February had very low pan evaporation, where as April, May, June, July and August were having maximum values. The other months of the year were conducive to cause intermediate level of this parameter. It may be concluded that under high

temperature and dry conditions, the pan evaporation was maximum and the low temperature and the fog prevailing in the months of December and January caused a significant decrease in it.

Figure 4: Monthly variation of Pan Evaporation.

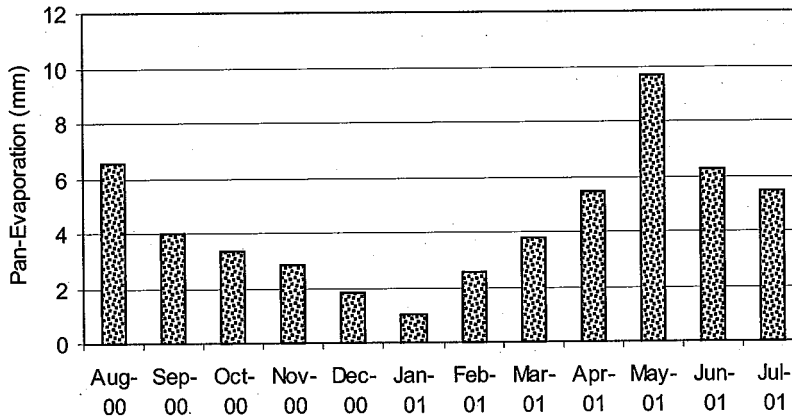

Natural changes in groundwater Quality

The groundwater was assessed 6 times during the study period after a span of 3 months. It was observed that the parameters of EC, SAR and RSC were comparatively higher in piezometers of Northern side than the Southern, and on Eastern side than the Western. The magnitude of EC was the highest in the Western side. No wide spatial differences were found in case of RSC whereas Northern land configuration was having maximum SAR. The piezometer N3 was mostly assessed with the highest values of EC, SAR and RSC throughout the study period and indicated the exceptional behaviour. The piezometers installed in the SEB (SEB-E & SEB-N) were mostly found with higher values of the studied parameters indicating a slight salt movement of salts from the catchment area towards the SEB.

The quality of groundwater remained fairly consistent during the first four quarters with only spatial variations discussed as above. When this period was correlated with the rainfall pattern of this time span, it could clearly be inferred that non-significant changes in quality of groundwater could be attributed to the consistent dry spell with no intensive rainfall in monsoon season 2000 (Figure 4). The enhanced intensity and quantity of rainfall in monsoon 2001 indicated its impact on groundwater quality, which was resultantly diluted. The magnitude of parameters in quarter five supported this inference (Figure 5). The recorded values of SEB-E piezometer increased highly indicating a clear salt movement into the SEB with intensive rains. Similar behavior was also observed for other piezometers close to SEB. The subsequent dry spell from October to December caused a reversion of the dilution effect into concentration impact and observed values of EC, SAR, and RSC again went low.

Figure 5 Temporal Variation of different Water Quality Parameters in SEB-E Piezometer.

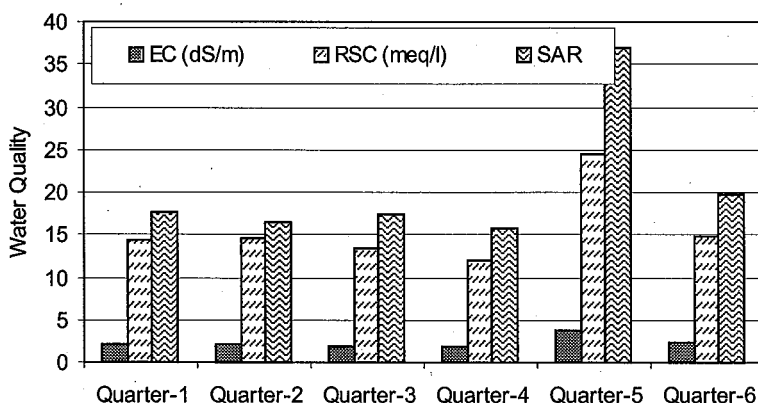

Natural soil salinity / Sodicity changes

Horizontal and vertical variations of salinity and sodicity parameters (EC, SAR and pH) were observed in the catchment area at the time of initiating this study. The surface with 0-15 cm depth of the soil was saline sodic with magnitude of EC, SAR and pH more than critical values of 4 dSm⁻¹, 15 and 8.5 respectively. The degree of salinity / sodicity decreased downwards into lower profile but the subsoil up to 165 cm depth was not found to be normal. Rather, it was assessed as saline sodic or sodic. The spatial variations within the catchment area were very clear in respect of EC, pH and SAR e.g. for top 0-15 cm layer SAR varies from minimum 43.65 (acre 12/4) to maximum 77.25 (acre 11/88).

The consistent dry spell of April 2000 to April 2001 with nominal monsoon rains caused concentration of salt in the surface and subsurface soil and degree of salinity / sodicity was enhanced many times. The impact was very much pronounced in the surface 0-15 cm depth as shown in Figure 6 and 7.

Figure 6: Impact of Rainfall on EC in Top 15 cm. of Soil for Acre NO. 11/16.

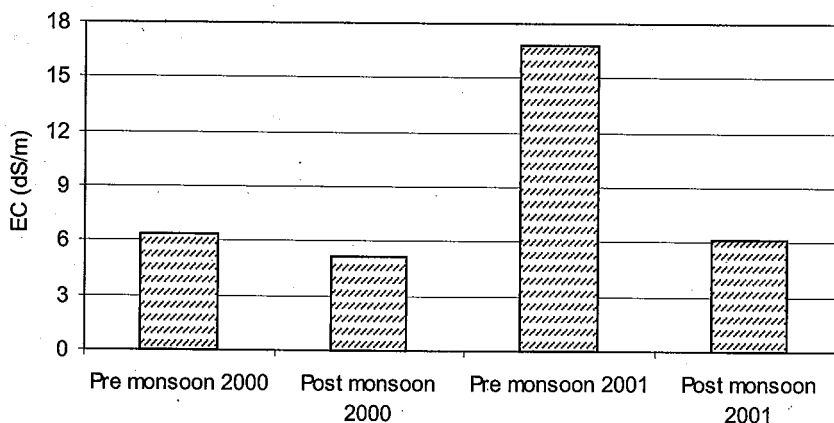
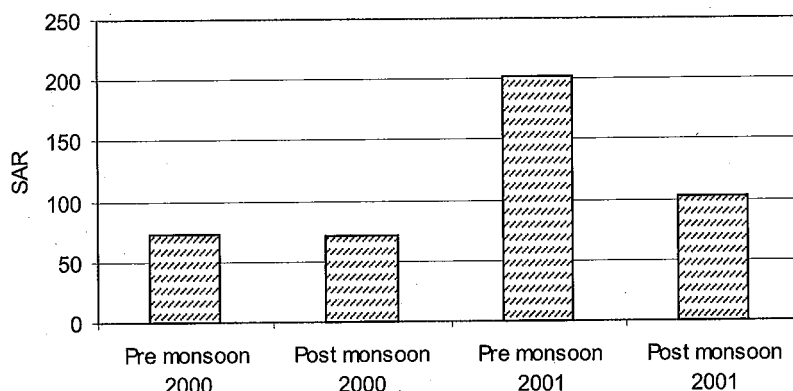

Figure 7: Impact of Rainfall on SAR in Top 15 cm. of Soil for Acre NO. 11/16.



It indicates that EC of acre No. 11/16 increased from 6.42 to 16.8 dSm^{-1} , which was calculated as 161 % or 2.6 times increase. The SAR of this very acre was enhanced from 72.45 to 202.29, which was about 2.79 times more than the original one. This trend was found in whole of the catchment area with variable impact of severity in different parts. However, the intensive rains of monsoon reverted the situation and the concentration process was converted in to dilution and leaching. The EC and SAR of the same acre (11/16) was decreased respectively from 16.8 dSm^{-1} and 202.29 (pre-monsoon, 2001) to 6.12 dSm^{-1} and 102.36 (post-monsoon, 2001). The effect on soil pH was observed as slightly deviating. The extreme soluble salt concentration in dry season decreased the soil pH, which was further decreased in monsoon 2001 as a result of appreciable reduction in SAR.

Changes of Soil and Groundwater Salinity / Sodicity in Relation to Reclamation Activities

Significant changes are brought in the soil characteristics when reclamation activities are started. Natural variations do not remain valid and soil health start improving rapidly. To compare the natural and man-initiated changes, reclamation activities (gypsum application, mixing, leaching and subsequent growing of rice crop) were started in acre number 11/25, 12/4 and 12/5 of the catchment area. The soil surface EC (0-15 cm) decreased to permissible limits, of less than 4 dSm^{-1} , in all these acres after growing only first rice crop subsequent to application of amendments and leaching (Table 1). There was very pronounced decrease in pH and SAR but values were still higher than the critical limits of 8.5 and 15. Gypsum requirement was also reduced. Hence, it can be concluded that reclamation activities proved positive and clearly conducive towards improving soil health compared with simple cultural operation and leaving the salt affected soil prone to natural climatic conditions.

Table 1: Effect of Reclamation Activities on Soil Properties (0-15 cm Depth).

Acre #	EC (dSm^{-1})		pH		SAR		Gypsum requirement (t/acre)	
	Before rice	After rice	Before rice	After rice	Before rice	After rice	Before rice	After rice
-								
4	17.19	3.24	9.82	9.01	92.2	28.8	4.64	1.72
5	8.6	3.87	9.93	8.07	193.5	30.3	8.94	3.44
25	15.64	3.45	9.81	8.90	183.2	39.6	6.71	2.58

The reclamation activities also affected the groundwater quality. It was observed that EC, SAR and RSC of piezometer S₂ and S₃ (installed in area No. 4) were very high at the end of fifth quarter in which reclamation was started. Similar trend was also found in E₂ and E₃ (installed in acre 25) but somewhat later (quarter six). The higher magnitude of values in SEB-E compared with SEB-N not only supported this point but also indicated the flow of salts towards the SEB as a result of reclamation process. To ascertain this fact a new piezometer SEB-S was installed during the reclamation activates, which were going on in the adjacent Southern acre to SEB. The two times analysis of the groundwater collected from this piezometer clearly proved this viewpoint. All the determinations (EC, SAR, RSC, CO₃, HCO₃, Ca + Mg and Na) here were higher than the SEB-N where no reclamation operations were being carried out (Table 2). A critical consideration of the water constituents showed that carbonates and bicarbonates of Na were moving towards the SEB of along with the irrigation or rainy water.

Table 2 Effect of Reclamation Activities on Groundwater Quality.

Sampling Dates	Piezo-meters	EC (dS m ⁻¹)	CO ₃ (meL ⁻¹)	HCO ₃ (meL ⁻¹)	Ca+ Mg (meL ⁻¹)	Na (meL ⁻¹)	SAR	RSC (meL ⁻¹)
May 28, 2001	SEB-E	1.8	5.0	9.0	2.1	16.1	15.7	11.9
May 28, 2001	SEB-N	1.5	3.0	9.5	1.6	13.2	14.8	10.9
Aug. 28, 2001	SEB-E	3.8	4.0	22.0	1.9	36.5	37.1	24.1
Aug. 28, 2001	SEB-N	1.1	1.0	10.5	1.5	9.7	11.2	10.0
Oct. 3, 2001	SEB-E	3.1	4.0	19.0	1.3	29.5	36.6	21.7
Oct. 3, 2001	SEB-N	1.2	1.0	11.5	1.4	10.1	12.1	11.1
Oct. 15, 2001	SEB-E	3.0	2.0	20.5	2.0	27.7	27.7	19.5
Oct. 15, 2001	SEB-S	2.0	2.0	10.5	2.4	17.4	16.1	10.2
Oct. 15, 2001	SBE-N	1.2	1.0	9.5	1.5	10.4	11.9	9.9
Nov. 28, 2001	SEB-E	2.3	-	17.0	2.2	20.5	19.8	14.8
Nov. 28, 2001	SEB-S	1.5	-	12.0	1.2	13.9	17.7	10.7
Nov. 28, 2001	SEB-N	1.3	-	12.0	2.1	10.7	10.6	9.9

CONCLUSIONS

- Monsoon season of 2000 did not bring significant rainfall (140 mm) but monsoon, 2001 was very much fruitful with total rainfall of 499 mm. There was consistent dry spell in post monsoon of 2000 and 2001.
- Pan evaporation varied in between 1-9.7 mm. The period (November to February) was having minimum while the period (April to August) indicated maximum values of this parameter.
- Groundwater quality did not change during dry spell. Salts diluted after intensive rainfall and concentrated as result of reclamation activities.
- Soil salinity/sodicity parameters increased during dry spell and decreased due to intensive rainfall. Reclamation activities (application of amendments, leaching and rice growth) rapidly decreased soil EC, pH and SAR.
- No significant movement of salts was observed under natural conditions except under very intensive rainfall. However, the reclamation process caused sequestering appreciable amount of salts in SEB.

REFERENCES

- Ceuppers, J., M.C.S. Wopereis and K. M. Miezán, 1997. Soil salinization processes in rice irrigation schemes in the Senegal River delta. *Soil Sc. Soc. Am. J.* 61: 1122-30
- Hussain, N., A. Ali, M. Saleem & A. R. Nasim, 2000, Management of saline sodic soil with brackish ground water employing gypsum and soil ripping. *Int. J. Agric. Bio.* 2 (1-2) P. # 69-73
- Hussain N., G. D. Khan, G. Sarwar & M. S. Dogar, 1990, Studies on various approaches for restoring physical properties of sodic soil. *Proc. Indo- Pak Workshop on Salinity and Water Management.* Feb. 10-14, 1990, Islamabad, Pak. PP. 107-117
- Richards, L.A. 1954. *Diagnosis and improvement of saline and alkali soils.* USDA-SCS Agric. Handbook No. 60. U. S. Govt. Print. Office Washington, DC.

Requirements and Constraints for Sustainable Shallow Groundwater Pumping for Salinity Control in Irrigated Areas

Evan Christen¹ and Shahbaz Khan²

ABSTRACT

Many irrigation areas are facing the problems of high watertables and soil salinity. This paper shows how generalised assessment can be made of the drainage requirement as well as the assessment of the drainage timing. For the case study area (Coleambally Irrigation Area) this showed a requirement of 0.25 – 0.5 ML/ha/yr over the past ten years. Assessment of where drainage is required can be undertaken by analysis of the spatial distribution of the groundwater mound and depth to watertable. Whether reuse is possible or disposal is required depends upon the groundwater salinity. Using these assessments the target areas for pumping can be determined. The fact that whether groundwater pumping can occur or not, depends upon the presence of adequate shallow aquifers. Analysis of the Coleambally area found that the potential areas for pumping were not evenly distributed. This requires planning to ensure those areas that cannot undertake pumping are not adversely affected by those that do. This is likely to occur if the water pumped is disposed of into irrigation or drainage channels. In the area studied in Coleambally the areas most likely to have potential for groundwater pumping were at the head end of irrigation channels and the areas least likely to be able to implement pumping on the tail end. This means that area wide planning is required before any sort of drainage is implemented to ensure the productivity and sustainability of all areas in an equitable fashion.

INTRODUCTION

In the Riverine plains the aquifer system consists of three formations (Figure 1). The top layer, which extends from the surface to about 70 m deep, is known as the Shepparton formation. It consists of a matrix of clay, silt and silty clay, with lenses of fine to coarse sand and gravel. Due to differences in hydraulic properties within the Shepparton formation, it has been further subdivided into two layers. The upper layer, roughly the top 20 m is known as the Upper Shepparton (US) and the lower layer is known as the Lower Shepparton (LS). The transmissivity of aquifers in the Shepparton formation is very low and varies in the range of 10-500 m²/day. The formation below the Shepparton formation is known as the Calivil formation. It extends between 70-130 m from the surface and comprises extensive sand and gravel layers interspersed by kaolin-type clay layers. The deepest aquifer layer at 130-200 m is known as the Olney or Renmark formation. It consists of extensive sand and gravel deposits with layers of lignites.

¹ Irrigation and Drainage Engineer (Research), CSIRO, Land and Water, Griffith, NSW, Australia

² Senior Scientists, CSIRO, Land and Water, Griffith, NSW, Australia

Figure 1: North to south transect through Easting 396348(m)

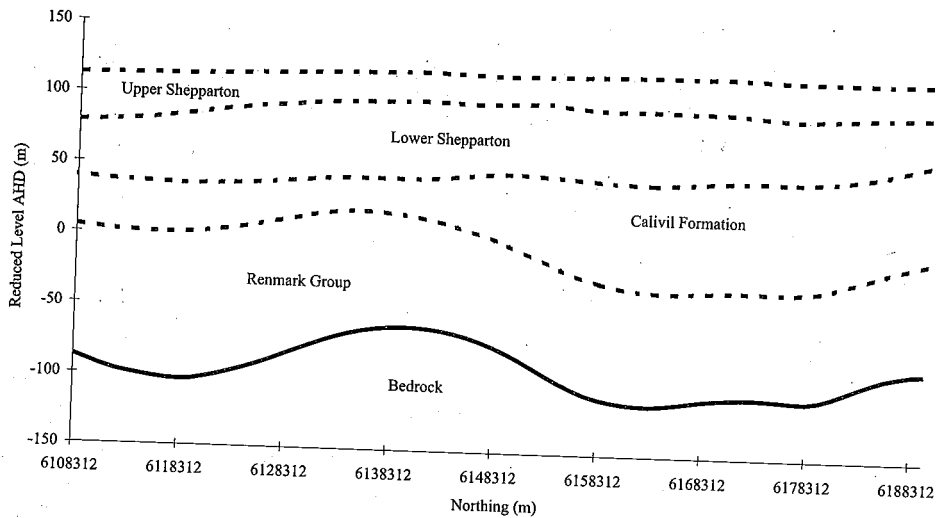

The deeper aquifers (Calivil and Renmark formations) have high transmissivities in the order of 1000-3000 m²/day. Private pumping by irrigators have established that good salinity groundwater, <0.5 dS/m, exists in these deeper aquifers. There may also be reasonable quality water available in shallow aquifers (Shepparton formations), which have not been previously assessed. Shallow groundwater pumping is important for the following reasons:

6. Scenario analysis using groundwater model of the Coleambally Irrigation Area (Prasad et al. 2001) and the Coleambally deep bore project (Lawson and van der Lelij 1992) have shown that there is little drawdown in shallow aquifers due to pumping from the deeper aquifers and the drawdowns observed tend to be localized.
7. Pumping of the shallow aquifers can reduce waterlogging and salinisation by lowering pressure levels in the shallow aquifer.
8. Shallow pumping may make additional water available in times of reduced allocations.
9. At present licensing provisions in New South Wales for groundwater allow unrestricted pumping from shallow aquifers.

For the above-mentioned reasons it is useful to identify the potential requirement for shallow groundwater pumping and the potential constraints. The Coleambally Irrigation Area is used as a case study.

METHODS AND RESULTS

Coleambally Irrigation Co-operative Ltd (CICL) maintains and monitors a network of 605 piezometers inside the boundary of the CIA. These piezometers are read twice a year during February/March and August/September. Piezometric data for the period 1985 - 1999 were available. In 1998 CICL also undertook a salinity survey of these piezometers. The data were analysed to assess the trends in watertables over time and evaluate the suitability of the groundwater resource for conjunctive reuse.

Pumping Requirements

Groundwater Conditions and Drainage Requirement

Groundwater conditions in the Shepparton formation have been extensively reported (van der Lely et al 1987, van der Lely 1992; CICL 1998, 1999). Watertables in the CIA were 20 m deep before the start of irrigated agriculture in the mid 1960s and rose dramatically until reaching their peak in 1996 (CIC 1998) when the watertable was within 2m of the surface over 31% of the CIA. It is reported that piezometric levels have risen since 1986, but they have fallen from 1996-1998. Figure 2 shows an area-wide hydrograph of the geometric mean of piezometric readings for the period 1990-1999 for both March and September. The March values are always higher than the average September readings and display less variation. This is because irrigation takes place during September to March, which causes recharge and hence piezometric levels increase. The final piezometric level does not vary greatly as there is a biophysical constraint in the amount of groundwater discharge, and as irrigation intensity does not vary greatly from year to year the level of recharge is maintained.

Figure 2: March and September hydrographs of geometric mean of piezometric readings

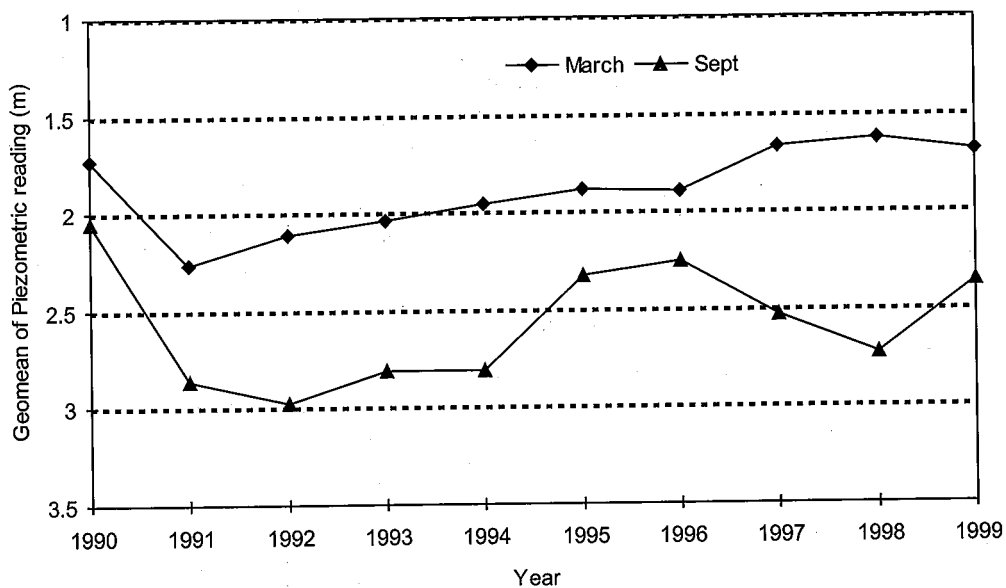

The September readings display greater variation depending upon rainfall during the non-irrigation period. These trends indicate that shallow groundwater pumping is feasible towards the end of the irrigation season for reuse or during Autumn/Winter if the water is not reused.

Conceptually the use of shallow groundwater pumping is to remove excessive water from the shallow aquifer, thus lowering watertables and hence controlling salinity in the root zone. The lowering of watertables reduces discharge from the watertable by capillary up flow and evaporation, which causes salts to accumulate in the upper layers, and provides the opportunity for salts to be flushed down out of the root zone to the watertable. Thus, there are two aims: preventing discharge and thus salt accumulation, and providing adequate flushing after periods of salt accumulation in the root zone. In September watertable levels are deep (Figure 2) and thus as irrigation occurs there is opportunity for salts to be flushed from the rootzone. As the irrigation season progresses watertables rise and the opportunity for salt leaching is reduced. At the end of the irrigation season watertables are at their highest and the application of water at the surface is stopped. This is the period of greatest risk for root zone salinisation as watertables are shallow and there is no downward

movement of irrigation water to balance the upward movement. Thus for shallow groundwater pumping, the most effective period for pumping will be at the end of the irrigation season. The aim is to prevent groundwater discharge by evaporation that leaves salt in the root zone and provides the opportunity for leaching by winter rainfall. By analyzing the watertable surface at different times the change in storage in the upper aquifer can be estimated. Figure 3 shows the area wide net recharge (positive values) and discharge (negative values) for the irrigation season (September to March) and non-irrigation season (March to September). This shows that net discharge occurs in the winter period, varying from 20 to 60 GL per year. If this were evenly distributed over the CIA this would be the equivalent of 0.25 – 0.5 ML/ha/year.

Figure 3: Net change in US aquifer storage for winter and the following summer (Christen et al. 2000)

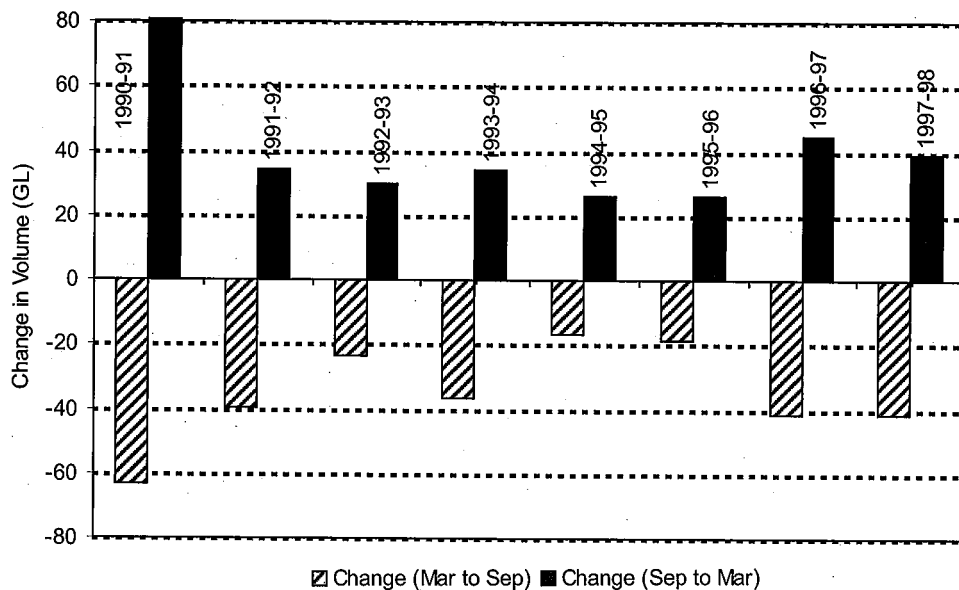

Some of this discharge may occur as downward leakage to the deeper aquifers; however, the majority will be lost to evaporation from the watertable or as discharge into drains and swamps. As well as controlling soil salinity it would be useful to prevent this discharge into surface features by groundwater pumping. Pumping in the autumn period would be useful; however, reuse of the groundwater for irrigation at this time will be less feasible. Groundwater pumping during the peak irrigation season would allow maximum dilution and hence conjunctive reuse, yet this is not the most efficient period for pumping for salinity control. This leads to the need for storage of groundwater and/or off site disposal. The timing of shallow groundwater pumping with respect to efficiency of salinity control and reuse/disposal options is an area that requires further investigation.

SPATIAL ANALYSIS OF REQUIREMENTS FOR SHALLOW GROUNDWATER PUMPING

The criteria for suitability for shallow pumping adopted were that there should be a high water table ≤ 2 m and that the salinity of the groundwater should be ≤ 5 dS/m. These criteria were determined on the basis of potential shallow groundwater pumping of 1ML/ha/year, surface irrigation supply water salinity of 0.2 dS/m, target salinity for conjunctive use of 0.8 dS/m and total irrigation

application of 8 ML/ha/year. However, if 0.5 dS/m is taken as the combined salinity then only groundwater up to 3.5 dS/m may be used.

Figure 4 shows the top of the groundwater mound (>122m AHD), the areas where watertable depths were within 2 m of the land surface in September 1999 and where shallow groundwater salinity is less than 5 dS/m. The peak of the groundwater mound is important as this is a high recharge area and is likely to spread an impact on adjoining areas. Where the peak of the groundwater mound and the shallow watertables (<2m deep) overlap will be key target areas for shallow groundwater pumping. The groundwater salinity indicates potential for reuse and need for disposal, generally the eastern margin of the CIA has relatively good quality shallow groundwater, with some more restricted areas of good quality water in the middle and western areas.

Figure 4: Shallow watertables, groundwater mound and areas of salinity less than 5 dS/m (5000 EC) for 1999 in upper Shepparton

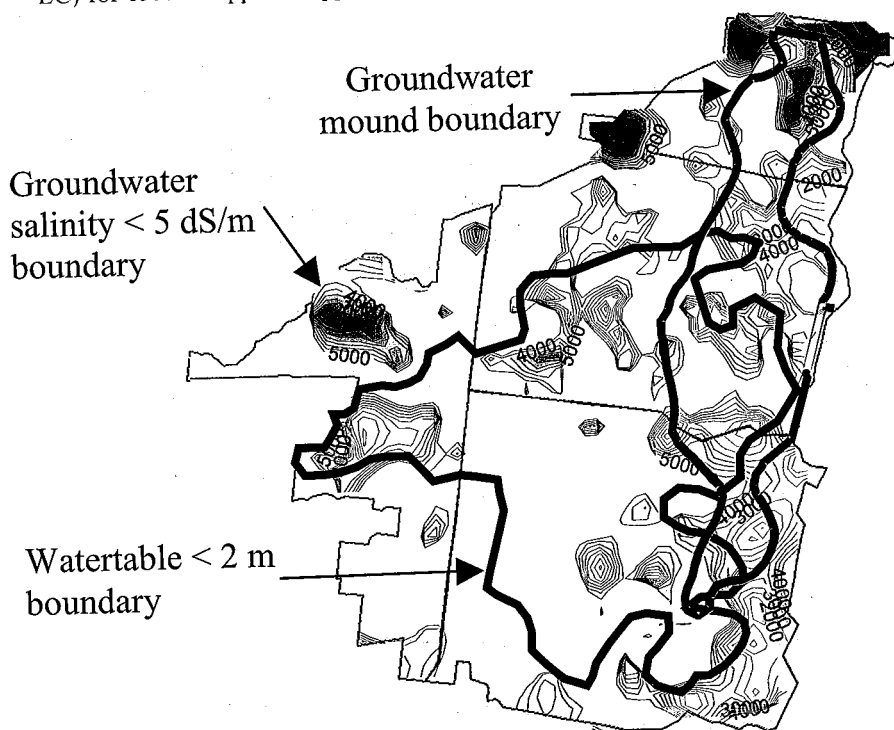

Using this information four areas can be distinguished for shallow groundwater pumping, Figure 5, providing an area-wide first estimate. Obviously site-specific investigations will be required to determine the actual shallow aquifer quality and site suitability for shallow groundwater pumping.

PUMPING CONSTRAINTS

For implementation not only is a detailed understanding of the site specific aquifer geology required but also an assessment of the potential impacts of reuse of more saline water on the local area and downstream water users is needed. This becomes extremely important if saline groundwater is disposed of by dilution into irrigation channels or directly or indirectly (by farm run off) into drainage channels. In this situation the increased irrigation or drainage water salinity will affect the

downstream users, thus threatening their productivity and sustainability. This is especially so if the downstream users are restricted in their access to groundwater pumping to control salinity. Restriction to shallow groundwater pumping is due to the absence of suitable aquifers. Figure 6 shows the southeastern section of the CIA with the areas where potential aquifers exist in the background. This is overlain by the channel supply network, over which there are two shaded areas, one being where aquifers for groundwater pumping are generally likely to be present and the other where aquifers are generally less likely to be present.

Figure 5: Potential areas and classes for shallow groundwater pumping

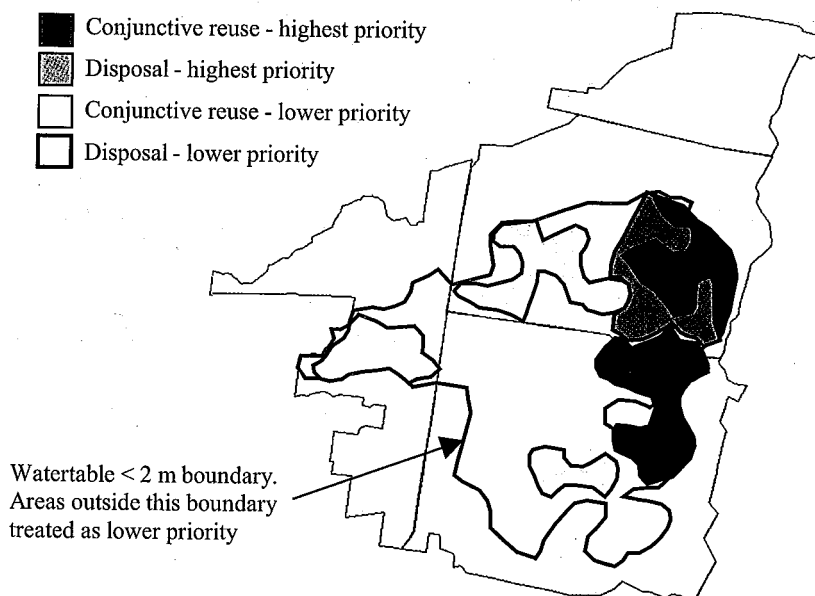

The area where there are poor prospects for finding suitable aquifers is generally at the tail end of the irrigation supply channels. This means that if saline water is disposed of into the supply channel it will be delivered to downstream users who have little opportunity of implementing groundwater pumping themselves. This being the case, careful consideration is required of the equity issues associated with disposal of drainage water by dilution in irrigation channels. Even where the drainage water is reused on farm there is potential for the water to move off farm as surface runoff and thus increase the salinity of the drainage system. This will adversely affect downstream users of the drainage water, who are being encouraged by irrigation companies to reduce the drainage from irrigated areas, especially where there are contaminants in the drainage water.

Figure 6: Potential upstream pumping areas and respective downstream receiving areas (Rogers and Christen 2001)

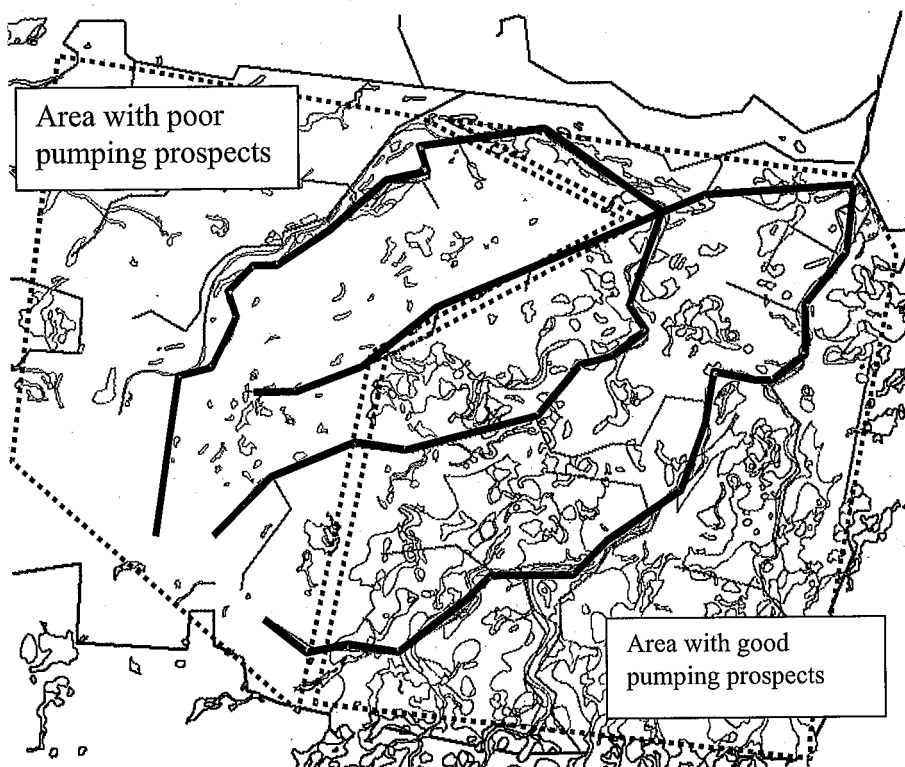

These complex factors mean that analysis of the potential for all areas to undertake groundwater pumping or some other form of drainage is required before initiating pumping or drainage anywhere. This means that a systematic planned approach to groundwater pumping is required which recognizes that the interests of downstream irrigators have to be protected.

CONCLUSIONS

The area-wide drainage requirement for the CIA was found to be 0.25-0.5 ML/ha/year. The timing of this drainage would be best suited to autumn, thus reducing evaporative loss and discharge to surface features and allowing increased leaching by winter rainfall.

By analysis of the groundwater mound, depth to watertable and shallow aquifer salinity the first estimate of where shallow groundwater pumping needs to be targeted can be made and the opportunity for reuse or the need for disposal can be identified. It was found that there is a groundwater mound along the eastern edge of the CIA, which needs to be reduced as a priority to assist in controlling shallow watertables in the area. Shallow groundwater pumping for conjunctive use can only occur in a small portion of the CIA, as the areas of low salinity water are restricted. Most of the water from shallow pumping will have to be disposed of.

Analysis of the spatial distribution of possible shallow aquifers, and hence, probable pumping sites have shown a very uneven distribution. This requires that area-wide planning to be undertaken before the commencement of pumping to ensure that those in areas with restricted opportunities for drainage are not adversely affected. In the case study area most of the potential pumping area was at the upper end of the irrigation channel network, the tail end areas would have very restricted opportunity for groundwater pumping. Thus serious consideration is required before allowing any increases in irrigation or drainage channel water salinity from upstream pumping and disposal (or runoff) as this may have severe impacts on the downstream users.

ACKNOWLEDGEMENTS

We acknowledge funding from Coleambally Irrigation Co-operative Ltd. and the Australian Centre for International Agricultural Research. Thanks also to all those at Coleambally Irrigation Co-operative Ltd. and the Department of Land and Water Conservation, Leeton for providing the data.

REFERENCES

- Christen, E.W., Prasad, A. and Khan S. (2000). Annual net recharge analysis for the Coleambally Irrigation Area using piezometric data. Technical report 01-01. CSIRO Land and Water, Griffith, NSW 2680.
- CICL (1999). Coleambally Irrigation Corporation Environmental Report 1999. Coleambally Irrigation Corporation, Coleambally, NSW. ISBN 0-646-38345-0
- CICL (1998). Coleambally Irrigation Corporation Annual Environmental Report 1998. Coleambally Irrigation Corporation, Coleambally, NSW.
- Coleambally Land and Water Management Plan (1996). Coleambally Land and Water Management Plan, Draft 1996. Anon.
- Lawson, S. and van der Lelij, A. (1992). Coleambally Deep Bore project – Analysis of long term pumping test. Water Resources Commission, Leeton, NSW.
- Prasad, A., Christen, E.W. and Khan, S. (2001). The potential for deep groundwater pumping in the control of irrigation induced salinity in the Riverine plain: A case study of the Coleambally Irrigation Area. CSIRO Land and Water Technical Report No. 01-01. Griffith, NSW, 2680.
- Rogers, M. and Christen, E.W. (2001). Aquifer identification, characterization and sustainable use for salinity control by shallow groundwater pumping: A case study of the Coleambally Irrigation Area. CSIRO Land and Water Technical Report No. XX-01. Griffith, NSW, 2680. Draft.
- Van der Lelij, A., Ellis, L. and Gee, B., (1987). Groundwater hydrology of the Coleambally Irrigation Area. August 1987. Dept. Water Resources. ISBN 7240 3740 3
- Van der Lely, A. (1992). Environmental status of the Coleambally Irrigation Area and guidelines for future environmental management. Preliminary discussion paper. Dept Water Resources, Murrumbidgee Region.

Artificial Recharge Basin Siting: Verification of GIS Approach Through Geophysical Investigations

G. M. Shah¹, H. M. Nafees Ahmad², Asghar Hussain³ and Abdul Razzaq⁴

ABSTRACT

Water is an essential commodity to mankind. The largest source of fresh /reusable water lies underground. Due to limited availability of surface water the demand of usable groundwater is increasing day by day. This demand includes the requirements of domestic, drinking, agricultural and Industrial needs. The exploitation of fresh groundwater in bulk, without any planning/program, has resulted in lowering of groundwater level in many areas. This lowering of water level has alarmed the mankind to think and act for providing the artificial recharge to groundwater. Rechna Doab area is one of those areas where water level is going down rapidly. To maintain its level, it was felt to select a suitable piece of land that could be used as artificial recharge basin on the availability of excessive surface water, especially during the monsoon period. This paper discusses the results of electrical resistivity survey – a geophysical technique that was conducted at two different sites (identified through GIS) in the project area to demarket the presence of clay layer(s) between the land surface and water level for using the appropriate methods for artificial recharge. The interpretation of field data has helped in selection of artificial recharge basins. The results show good agreement between the GIS approach and geophysical investigations.

INTRODUCTION

Excessive exploitation of groundwater at a rate greater than replenishment causes declining groundwater levels over the long term and, if not corrected, lead to contamination and eventual mining of groundwater. Haider (2000) reported 59 billion m³ as annual groundwater pumpage in the year 1999. Due to the increasing water demand, in Punjab province alone, more than 500,000 tube wells have been installed by the private sector (PPSGDP, 2000). To maintain the groundwater levels and to prevent contamination of groundwater, artificial recharge of groundwater is becoming increasingly important in groundwater management and, particularly, in the conjunctive use of surface and groundwater resources.

The purpose of artificial recharge to groundwater is to reduce, stop, or even reverse declining levels of groundwater; to protect underground freshwater aquifer against saltwater intrusion/ upconing, and to store surface water, including flood or other surplus water and imported water, for future use. Three common methods of managed recharge are water spreading basins, pits, and wells. The main

¹ Director, PCRWR, Lahore, Pakistan

² Senior Researcher, PCRWR, Lahore, Pakistan

³ Spatial Data Analyst, International Irrigation Management Institute (IWMI), Lahore, Pakistan

⁴ Deputy Director, PCRWR, Lahore, Pakistan

theme of this paper is to evaluate the artificial recharge basin sites, which were identified through GIS approach, by electrical resistivity survey at the spot. In respect of site selection through GIS, a set of criteria acceptable for siting a recharge basin was established for transmitting layer and storing layer. A transmitting layer is defined here as the unsaturated soil profile in the basin area having conditions for infiltrating and conveying acceptable quality water to the aquifer system. Its evaluation is based on soil texture and salinity. The storing layer is the aquifer system having capability of storing percolated water and recovery by wells. This layer is evaluated on the basis of history of depth to water table, aquifer parameters and groundwater quality. The physiography, irrigation subdivision and storm water drainage network maps covering Rechna Doab were superimposed to determine the adequacy of siting of the artificial recharge basin.

Five areas (Figure 1) were identified in Lower Rechna Doab in the vicinity of Chenab and Ravi rivers, ranging from two to eleven thousand hectares in size. These areas fulfil the set of developed criteria/requirements i.e. water level should be more than six meters and subsoil should have porous texture.

Figure 1: Suitable sites identified through GIS for artificial recharge. Geophysical investigations – electrical resistivity survey

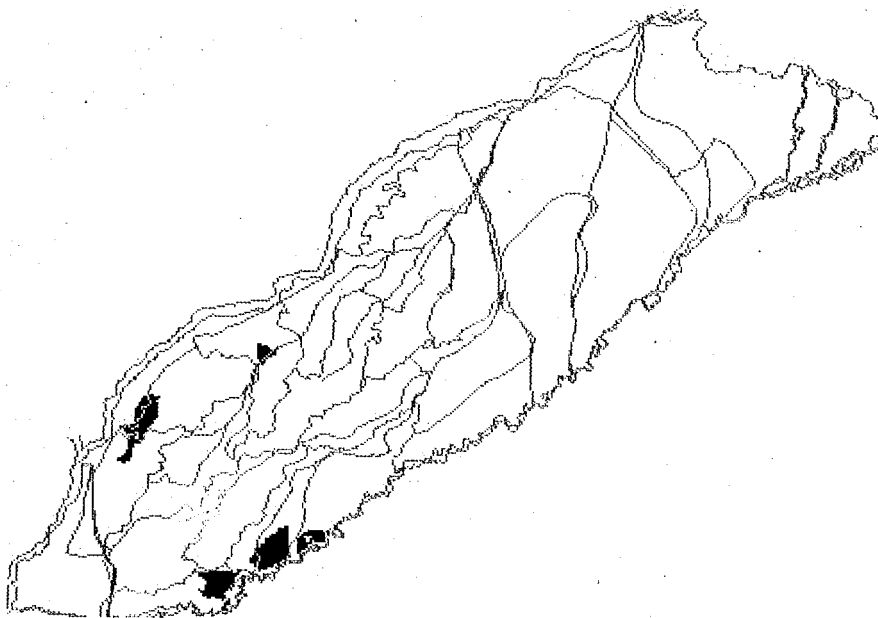

Geophysical investigations involve the measurement of the apparent resistivity of soils and rock as a function of depth or position to study the sub-surface hydrological set up of the area. The objective of electrical resistivity survey is to map the sub-surface changes in earth resistivity and correlate them with the hidden geological formations. The resistivity of any formation is mainly dependent on two factors, viz. the porosity of the formation and the salinity of the solution held in the pores. In water bearing formations the current is carried entirely by the dissociated ions of the salt held in solution.

Electrical Resistivity Survey can be used profitably for solving various groundwater problems such as:

- i. To determine qualitatively the type of water bearing formation, e.g., clay, sand, sandstone or gravel provided conditions are favorable and not complicated by abrupt lateral changes in lithology.
- ii. To differentiate between saline and fresh water aquifers, provided the lithology of the aquifer is uniform.

Terrameter SAS 300 B was used in the area to collect the field data. This instrument works on the basis of Ohm's law. SAS stands for single averaging system, a method whereby consecutive readings are taken automatically and results are averaged continuously until the Geophysicist is satisfied with the stability of the results. SAS results are more reliable than those obtained using single short systems. SAS comprises of a battery powered deep penetration resistivity meter. Ratio of potential and current (V/I) is calculated automatically and displayed in kilo-ohms, ohms or milli-ohms.

FIELD PROCEDURE

On the basis of recommended basins by GIS, geophysical investigations through electrical resistivity survey were done at two sites i.e. Jamal Pahar near Kamalia and Chak No.55 Mamu Kanjan. The sites were selected having dimension of 300×300 meters (9 ha) and 300×200 meters (6 ha). The field performa was so designed that maximum field data should be collected to get information on subsurface set up of formations within twenty five to thirty meters. The Spacing between Vertical Electrical Sounding (VES) was kept 100 meters. In all, twenty-eight VES were established in the two areas Fig-2 & 3.

Figure 2: Geophysical survey (probe location map) of Jamal Pahar area, Kamalia

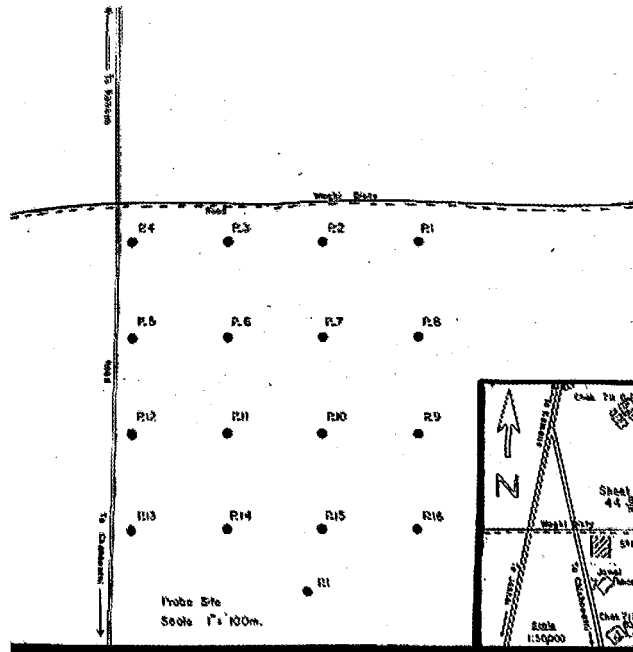
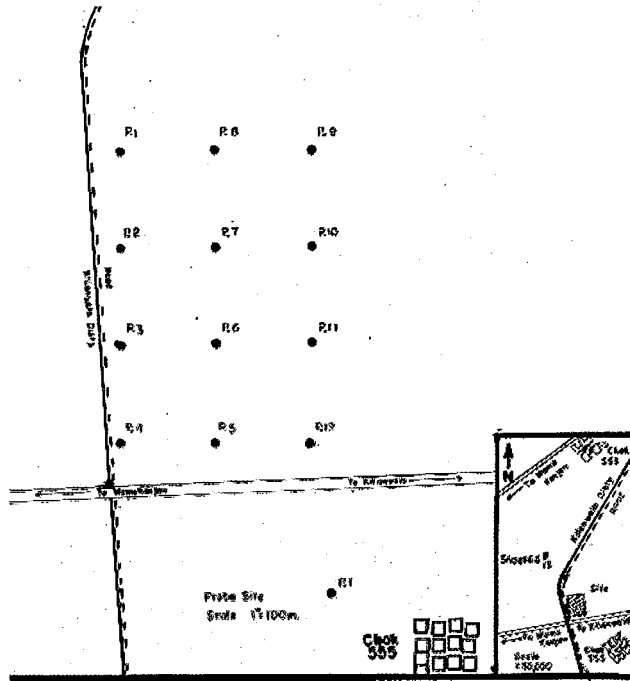
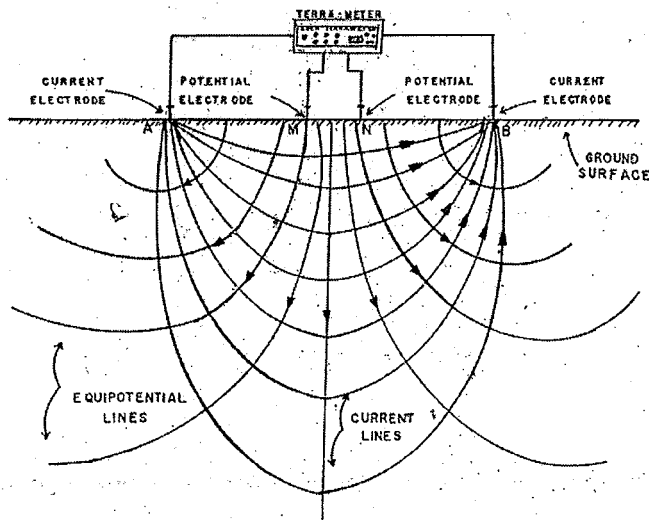

Figure 3: Geophysical survey (probe location map) of Chak 555, Mamun Kanjan.



The Schlumberger electrode configuration (Figure 4) was used during fieldwork for conducting the electrical resistivity survey keeping $AB \geq 5 MN$. The earth was energized by using the battery pack at various electrode spacing at one VES station. The instrument displayed value of V/I when multiplied by the constant

Figure 4: Setting of current and potential electrodes by Schlumberger electrode configuration.



'K', the apparent resistivity value for each electrode spacing was obtained. To know the true resistivity of various sub-surface layers field curves were plotted for further analysis. Apparent resistivity values were plotted against corresponding current electrode spacing i.e. AB/2 on log-log graph paper (base 62.5 mm) for further processing the field data.

INTERPRETATION

The aim of geophysical interpretation (Qualitative and Quantitative) of resistivity sounding data is to determine the thickness and resistivity of different horizons from a study of the VES field curves and to use these results for obtaining a picture of subsurface hydrogeological set up of the investigated area.

QUALITATIVE INTERPRETATION

In this regard, apparent resistivity contour maps at the value of AB/2 = 3 & 8 meters in respect of two areas have been prepared (Figure 5 & 6) to know the existence & trend of clay layer above the water level. It reveals that clay layer(s)/lens are present in the area and its thickness varies & disappears after reaching the depth of nine meters.

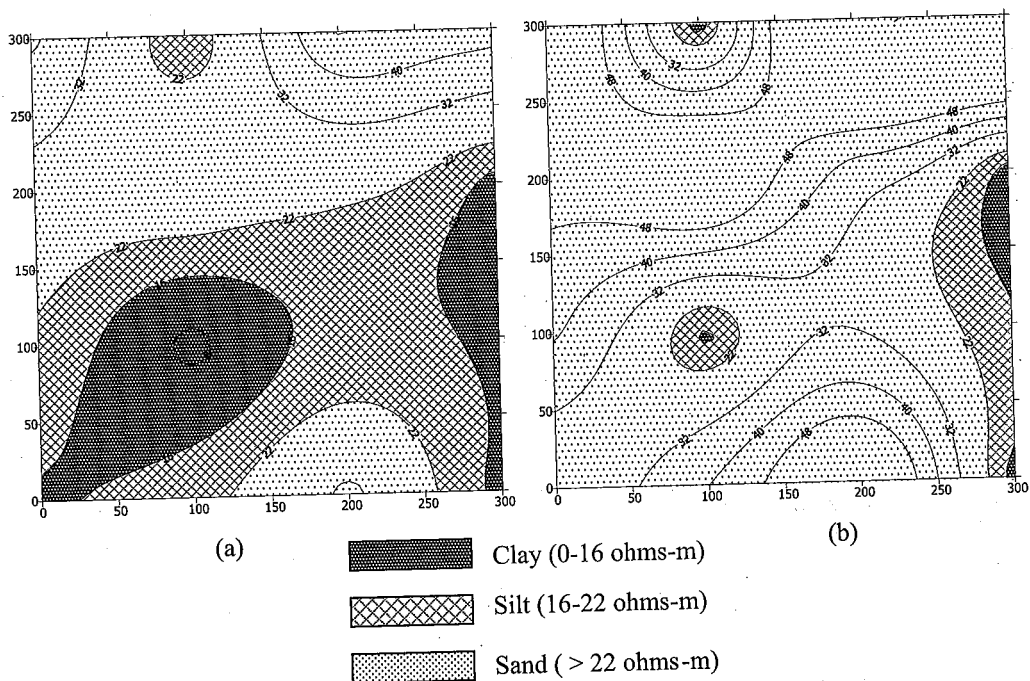

Figure 5: Apparent resistivity contour map at (a) AB/2 = 3m & (b) AB/2 = 8m Jamal Pahar, Kamalia

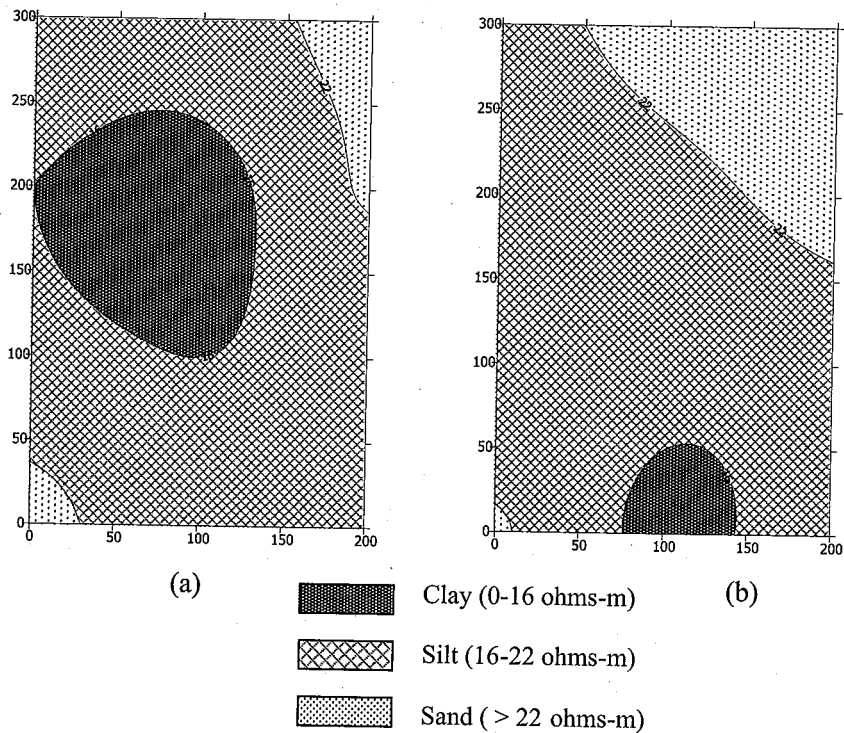

Figure 6: Apparent resistivity contour map at (a) $AB/2 = 3m$ & (b) $AB/2 = 8m$ Chak 555, Mamun Kanjan

QUANTITATIVE INTERPRETATION

Field curves were matched with the curves made by the computer for each VES and final interpretation was made. Lithological columns based on this interpretation are drawn and presented in Figures 7 & 8 for Kamalia and Mamun Kanjan areas respectively. The subsurface formations on the basis of electrical characteristics are classified into four distinct zones:

- | | | |
|------|----------------------------|------------------|
| i. | Low Resistivity Zone | 0-15 Ohm-meter |
| ii. | Medium Resistivity Zone | 16-40 Ohm-meter |
| iii. | High Resistivity Zone | 41-100 Ohm-meter |
| iv. | Very High Resistivity Zone | > 100 Ohm-meter |

LOW RESISTIVITY ZONE

This zone reveals the presence of impervious material like clay and silty clay with minor sand.

MEDIUM RESISTIVITY ZONE

This is interpreted as the presence of thin alternate layers of impervious and pervious material like clay and sand or sand with poor to marginal quality of water.

Figure 7: Lithological columns showing quantitative interpretation based on VES data for Kamalia area.

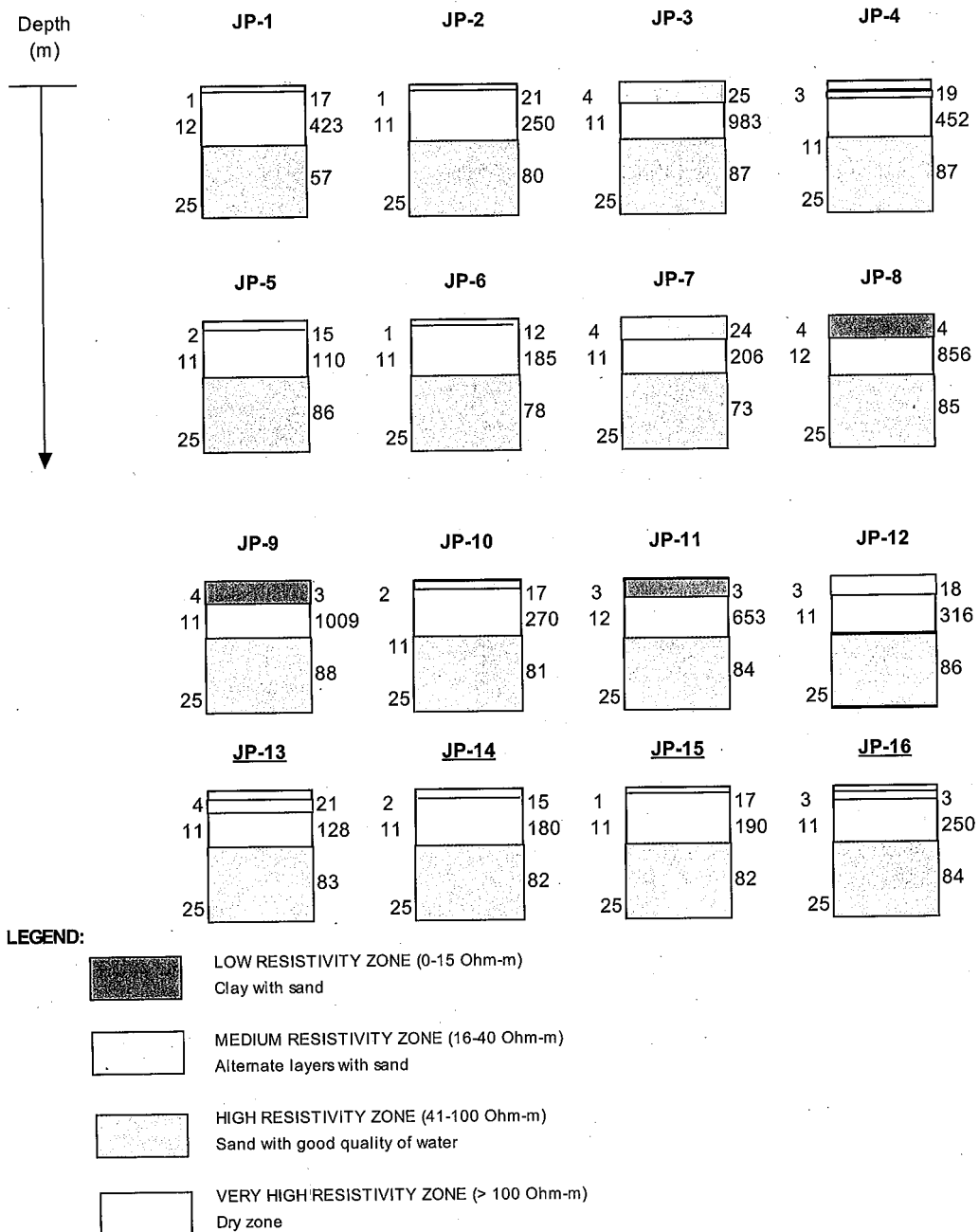
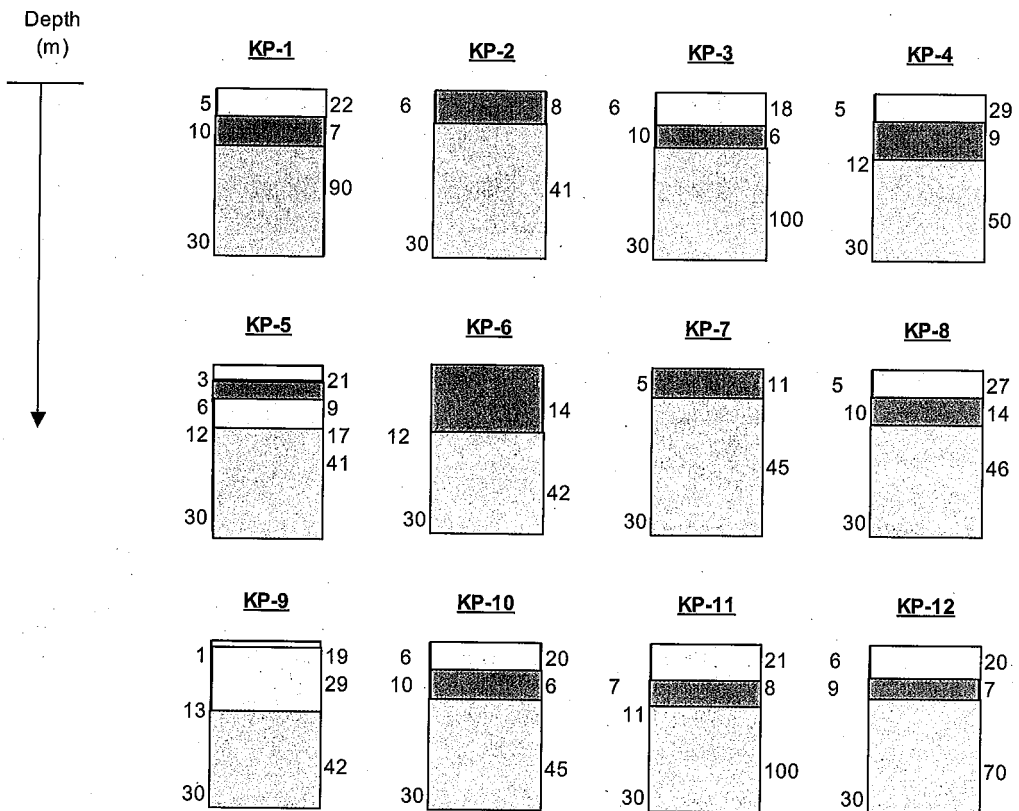

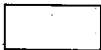



Figure 8: Lithological columns showing quantitative interpretation based on VES data for Mamun Kanjan area.



LEGEND:

-  LOW RESISTIVITY ZONE (0-15 Ohm-m)
Clay with sand
-  MEDIUM RESISTIVITY ZONE (16-40 Ohm-m)
Alternate layers with sand
-  HIGH RESISTIVITY ZONE (41-100 Ohm-m)
Sand with good quality of water
-  VERY HIGH RESISTIVITY ZONE (> 100 Ohm-m)
Dry zone

HIGH RESISTIVITY ZONE

This zone reveals the existence of pervious material like sand, gravel and kankres with rare impervious material like clay/silty clay having good quality of water.

VERY HIGH RESISTIVITY ZONE

This zone represents the existence of dry zone.

Based on the interpretation results it is concluded that Jamal Pahar area comes under medium to high resistivity zone with increasing depth whereas Mamun Kanjan area has very high to high resistivity zone. The groundwater level in Jamal Pahar, Kamalia area is about thirteen meters where as in Mamun Kanjan area groundwater depth is about seventeen meters. The apparent resistivity contour maps at the value of $AB/2=3$ & 8 meters show that there are clay lenses starting from 3m depth and disappearing almost at the depth of 8m at both the sides.

CONCLUSION AND RECOMMENDATIONS

Following conclusions are drawn from this study:

- The electrical resistivity survey results supplement/support the findings of GIS.
- In general, sand formation exists in the area.
- There are thin clay lenses, which start from 3m depth and almost disappear at 8m depth at both the sites.
- The groundwater level exists within thirteen and seventeen meters in Kamalia and Mamun Kanjan areas respectively.
- Keeping in view the existence and extend of sand formation, Northern part of Jamal Pahar - Kamalia and southern part of Mamun Kanjan investigated areas are recommended to be used for recharge basins.
- Water spreading and pits techniques be applied in Jamal Pahar area, whereas dug well (up to 10 meters depth) technique be applied in Mamun Kanjan area for recharge purpose.

REFERENCES

- Haider, Ghulam, 2000. Environmental impacts of groundwater use for agriculture. Proceedings of Regional Groundwater Management Seminar. Organized by Pakistan Water Partnership, Oct 9-11, 2000. Islamabad.
- PPSGDP, 2000. Institutional framework for groundwater management and regulation in Punjab. Technical Report No. 38. Punjab Private Groundwater Development Project Consultants.

Remote Sensing and GIS Based Analysis of Conjunctive Water Use in the Rechna Doab, Pakistan

Mobin-ud-Din Ahmad¹ and Wim G.M. Bastiaanssen²

ABSTRACT

Irrigation is practiced in the fresh groundwater quality areas in the Indus river basin with both canal and groundwater resources, i.e. conjunctive use. The total groundwater abstraction is unknown and this is a disadvantage for strategic groundwater resources management planning. The availability of satellite images gives a new opportunity to describe more comprehensively soil moisture in the root zone and actual evapotranspiration from irrigated crops. Knowledge on evapotranspiration has the advantage that it describes the real water depletion, which in water scarce conditions can differ significantly from the crop's maximum consumptive use obtainable from theoretical crop water requirement calculations. The resulting satellite based maps of actual evapotranspiration and soil moisture have been validated at two experimental fields. A detailed physically based agro-hydrological model (SWAP) is used to compute the water fluxes in the – sometimes deep – unsaturated zone. The combined use of the transient model output on soil water storage and moisture fluxes together with the remote sensing estimates has been used to obtain the seasonal soil water balances and net groundwater use of irrigated crops.

INTRODUCTION

Growing food and fibre demands require more effective use of the limited land and water resources, or to produce more yield with less resources (Guerra et al., 1998). The knowledge of existing land and water use patterns is of prime importance for natural resources managers; especially in developing countries where consumption in rural areas swallows the bulk of the water resources. The irrigation sector withdraws an estimated 80 percent of freshwater resources in developing countries (FAO, 1994). Although the public perception is that the irrigation sector wastes freshwater resources, this opinion is not necessarily correct. Vast volumes of canal water that initially missed the crop can be recaptured in the irrigation system by pumping groundwater from shallow aquifers, downstream capillary rise to crops, and return flow into tributaries or the main river itself. Recycling irrigation water considerably increases the overall irrigation efficiency and productivity of water (Bastiaanssen 2002a).

The development of evaluating irrigation systems has undergone major modifications during the last 20 years from classical irrigation efficiencies (Bos and Nugteren, 1974; Jensen 1977) to

¹ Ph. D. Fellow, International Water Management Institute (IWMI)

² Professor of Remote Sensing, International Institute for Geo-information Science and Earth Observation (ITC), Enschede, The Netherlands

performance indicators (Bos et al., 1994; Clemmens and Bos, 1990) and, more recently, into the framework of water accounting and regional scale water depletion processes (Molden, 1997; Burt et al., 1997; Clemmens and Burt, 1997). These analytical frameworks help in describing and understanding the flow path of water. One of the prerequisites to the application of those frameworks is accessibility to water balance data. This paper describes how total water use in an irrigated river basin can be evaluated through the quantification of the crop evapotranspiration and evaporative fraction by means of the surface energy balance. Since there is a direct link between the actual evapotranspiration and the soil water availability at various stages in the growing season, behaviour of evapotranspiration is information on soil moisture at the same time.

Evapotranspiration is usually estimated by conventional techniques based upon routinely collected data. This data is then used to compute the reference evapotranspiration, which differs considerably from the actual evapotranspiration and is not meaningful for the description of actual soil moisture status, or for soil water balance determinants. Note that the reference evapotranspiration can be as large as 10 mm d^{-1} and the actual evapotranspiration of the same land use classes, 1 mm d^{-1} .

Actual evapotranspiration can nowadays be estimated from satellite remote sensing (Engman and Gurney, 1991; Kustas and Norman, 1996; Bastiaanssen et al. 1999). Emerging developments in the field of remote sensing make it possible to overcome information limitations on soil water status and the actual evaporative depletion. As surface energy balances and crop water stress are directly linked to conjunctive use, variations in space and time are thought to be highly indicative for adequacy, reliability and equity in water use.

The objective of this paper is to create awareness about the technical feasibility of estimating net groundwater use at a multitude of scales up to the tertiary unit systems with the use of remote sensing and GIS data. To combat the 21st century's water scarcity, we have to transcend current applications and apply modern information technology creatively. The objective of this paper is to show how information technology can be applied to assess net groundwater use.

DESCRIPTION OF THE STUDY AREA

This research work was carried out in the Rechna Doab area of the Indus Basin irrigation system. The Rechna Doab is the interfluvial area between the Chenab and Ravi Rivers (Figure 1). It lies between longitude $71^{\circ} 48'$ to $75^{\circ} 20'$ East and latitude $30^{\circ} 31'$ to $32^{\circ} 51'$ North. The gross area of this Doab is 2.97 million ha, with a maximum length of 403 km and maximum width of 113 km, including 2.3 million ha of cultivated land. It is one of the oldest and most intensively developed irrigated areas of Punjab, Pakistan. The area falls in the rice-wheat and sugarcane-wheat agro-ecological zones of the Punjab province, with rice, cotton and forage crops dominating in summer season (*Kharif*), wheat and forage in winter season (*Rabi*). In some parts sugarcane is also cultivated which is an annual crop. Time series data hydrological and meteorological data has been collected from Water and Power Development Authority (WAPDA), Pakistan Meteorological Department and International Water Management Institute (IWMI).

For detailed analysis and understanding of different components at a field level, two sites Pindi Bhattian and Faisalabad were selected. The experimental site from where field scale data was collected is at Soil Salinity Research Institute (SSRI), Pindi Bhattian, which is located on the western border of Rechna Doab (co-ordinates: $73^{\circ} 20' 50.2''$ eastern longitude $31^{\circ} 52' 34.2''$ northern latitude). The site is flat and situated at an altitude of 212 m above sea level. The average

precipitation is approximately 500 mm yr^{-1} . Rice-wheat rotations are common practice. The phreatic surface is approximately 2 m deep from the soil surface.

Figure 1: Location of Rechna Doab in Punjab, Pakistan

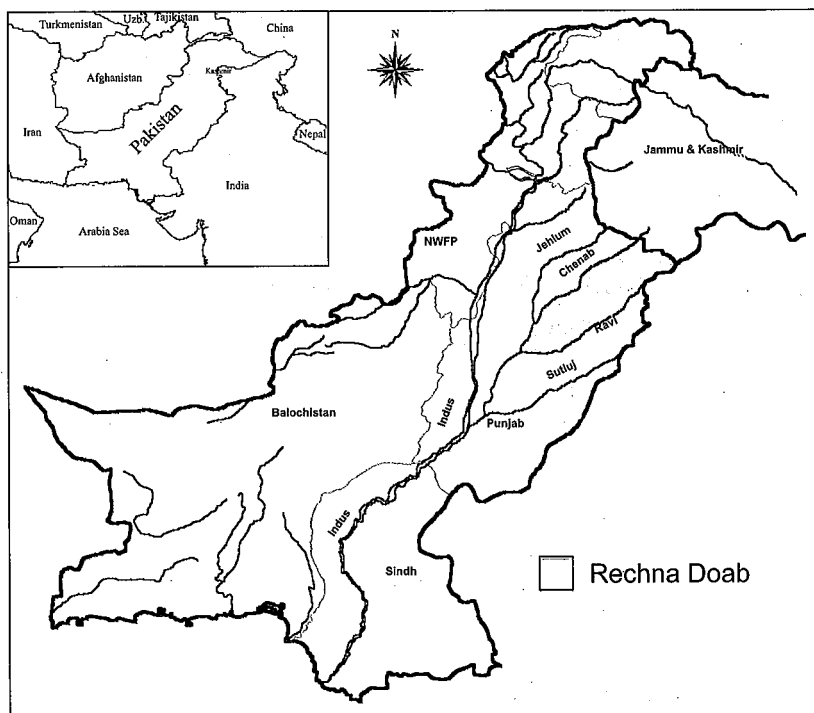

The second site is the experimental field of the Cotton Research Institute of Ayub Agricultural Research Institute (AARI), Faisalabad, which is situated in the centre of Rechna Doab (co-ordinates: $73^{\circ} 2' 49.8''$ eastern longitude $31^{\circ} 23' 26.2''$ northern latitude). The flat area lies at an altitude of 130 m above sea level. The climate is drier than in Pindi Bhattian with an average annual precipitation of 360 mm. Cotton-wheat rotations are practiced in this area and phreatic surface fairly deep, approximately 10 m below the surface.

Field data on various agronomic aspects and water balance components were collected for two growing season, *Kharif* (summer season) 2000 and *Rabi* (winter season) 2001. Bowen ratio towers were installed and operated from, June 21, 2000 to March 21, 2001, at both experimental plots. Near-surface atmospheric profiles of temperature, humidity and wind speed were measured along with precipitation and incoming solar radiation. For missing days, climatic data of nearest meteorological stations was collected. The irrigation regime was monitored with the help of cut-throat flumes and a current meter. Daily phreatic surface was recorded precisely in piezometers with *Diver* (automatic recorders) and manual measurement with sounding devices. Soil moisture content in the root zone (up to 100 cm) was monitored in the field with the help of a theta probe based on the frequency domain technique. The theta probe measures the volumetric soil moisture content by measuring changes in the dielectric constant.

FIELD SCALE METHODS AND RESULTS

In this study, the one-dimensional physically based Soil-Water-Atmosphere-Plant (*SWAP*) model is used. The *SWAP* model is based on the Richard's equation, which combines the Darcy's law and continuity equation, for moisture transfer and the advection-dispersion equation for solute transfer. *SWAP* predicts the dynamic interaction between soil, water, atmosphere and plant on a daily time step (Van Dam et al. 1997). It has been tested for a number of hydrological studies related under a wide range of climate and agricultural systems (e.g. Feddes et al., 1988). *SWAP* has been applied and validated for the irrigation conditions in Pakistan and India before (Bastiaanssen et al., 1996; Van Dam and Feddes, 1996; Smets et al., 1997; Beekma et al., 1997 and Sarwar et al., 2000).

In the present study, special consideration is given to divergence of the vertical soil moisture fluxes in the unsaturated zone. The *SWAP* model is calibrated and validated with *in situ* measurement of root zone θ and actual evapotranspiration ET_a for cotton-wheat and rice-wheat cropping system under deep and shallow phreatic surface condition respectively, which is unique to have them available under Pakistani conditions. The root mean square error (RMSE) between measured and simulated soil moisture content is found 0.021 and 0.027 $\text{cm}^3 \text{cm}^{-3}$ and for evapotranspiration 1.073 and 0.99 mm d^{-1} for Faisalabad and Pindi Bhattian respectively (Ahmad et al., 2002).

TEMPORAL PATTERN OF RECHARGE AND GROUNDWATER USE

Not all the water for irrigation is consumed by evapotranspiration. A fraction of the water infiltrated through the surface is reaching the groundwater system (figure 2).

Figure 2: Schematisation' of different water fluxes in vertical unconfined aquifer (I_{cw} is canal water irrigation, P_n is net precipitation, ET_a is actual evapotranspiration, I_{tw} is tubewell irrigation).

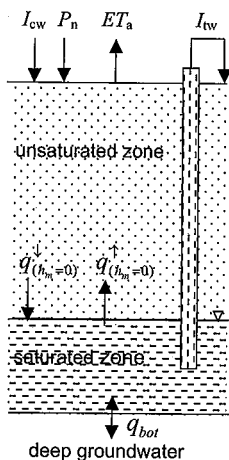

In order to assess sustainable groundwater pumping rates, the recharge as a result of irrigation returns flow/system losses in the cotton-wheat (table 1) and rice-wheat (table 2) cropping system to the phreatic surface (where matric head $h_m = 0$) has been quantified. The total irrigation in Table 1 and 2 is, therefore, broken down into canal water and groundwater irrigation. The net-groundwater use I_{ngw} ($I_{ngw} = I_{tw} + q_{(h_m=0)}^{\uparrow} - q_{(h_m=0)}^{\downarrow}$) is substantially less than the groundwater use I_{gw} ($I_{gw} = I_{tw} + q_{(h_m=0)}^{\uparrow}$) in both cases, which implies that recharge is a significant process.

Table 1: Net-recharge and net-groundwater use in cotton-wheat system at Faisalabad (Year 2000-01) with a deep phreatic surface.

Month	Recharge $q_{(h_m=0)}$ (cm)	Capillary Rise $q_{(h_m=0)}$ (cm)	Net Recharge q_{nr} (cm)	Canal Irrigation I_{cw} (cm)	Ground water Irrigation I_{tw} (cm)	Ground- water Use I_{gw} (cm)	Net ground- water use I_{ngw} (cm)	Groundwater recycling fraction ν (-)
May	1.36	0.00	1.36	7.62	0.00	0.00	0.00	0.00
Jun	1.35	0.00	1.35	0.00	0.00	0.00	0.00	0.00
Jul	1.17	0.00	1.17	0.00	0.00	0.00	0.00	0.00
Aug	1.73	0.20	1.53	19.28	0.00	0.20	0.00	0.00
Sep	2.42	0.42	2.00	0.00	8.63	9.05	6.63	0.19
Oct	1.93	0.69	1.24	5.28	0.00	0.69	0.00	0.00
Nov	3.00	1.12	1.88	0.00	0.00	1.12	0.00	0.00
Dec	0.89	0.46	0.43	10.00	0.00	0.46	0.00	0.00
Jan	1.32	0.91	0.41	0.00	0.00	0.91	0.00	0.00
Feb	2.84	0.50	2.34	0.00	8.44	8.94	6.10	0.28
March	2.79	0.09	2.70	14.88	3.76	3.85	1.06	0.14
April	2.45	1.30	1.15	0.00	6.51	7.82	5.36	0.08
Annual	23.26	5.70	17.56	57.06	27.34	33.04	19.15	0.16

Table 2: Net-recharge and net-groundwater use in rice-wheat system at Pindi Bhattian (Year 2000-01) with a shallow phreatic surface.

Month	Recharge $q_{(h_m=0)}$ (cm)	Capillary Rise $q_{(h_m=0)}$ (cm)	Net Recharge q_{nr} (cm)	Canal Irrigation I_{cw} (cm)	Ground- water Irrigation I_{tw} (cm)	Ground- water Use I_{gw} (cm)	Net ground- water use I_{ngw} (cm)	Ground- water recycling fraction ν (-)
May	0.00	2.56	0.00	0.00	0.00	2.56	2.56	0.00
Jun	0.00	2.68	0.00	5.00	5.00	7.68	7.68	0.00
Jul	2.62	0.78	1.84	4.07	4.08	4.86	2.24	0.13
Aug	16.93	0.32	16.61	9.15	23.16	23.48	6.55	0.41
Sep	9.63	0.00	9.63	0.00	14.52	14.52	4.89	0.52
Oct	2.37	0.06	2.31	0.00	0.00	0.06	0.00	0.00
Nov	0.92	0.85	0.07	0.00	8.09	8.94	8.02	0.00
Dec	1.04	0.38	0.66	0.00	0.00	0.38	0.00	0.00
Jan	2.21	0.25	1.96	0.00	6.98	7.23	5.02	0.27
Feb	1.29	0.12	1.17	0.00	6.41	6.53	5.24	0.17
March	1.24	0.18	1.06	0.00	6.10	6.28	5.04	0.16
April	0.66	0.26	0.40	0.00	6.75	7.00	6.35	0.05
Annual	38.91	8.44	30.48	18.22	81.09	89.52	53.59	0.23

There is more recharge in Pindi Bhattian than in Faisalabad. The monthly rate of recharge ranges between 0.89 to 3.00 cm at Faisalabad and 0 to 16.93 cm at Pindi Bhattian respectively. In Pindi Bhattian, 81% of the annual recharge occurs during the *Kharif* season. Such high range of recharge in Pindi Bhattian area is attributed to rice crop and shallow phreatic surface conditions. A sharp decline in phreatic surface is observed during the rice-growing season. This is the result of a high rate of groundwater extraction for irrigation. The annual groundwater resource ratio has been found to be 0.24 and 0.60 at Faisalabad and Pindi Bhattian respectively, i.e. the fraction of the total water supply results from groundwater irrigation. This reflects that the rice-wheat systems of Pindi Bhattian rely more on groundwater irrigation than the cotton-wheat area of Faisalabad. But an

appreciable amount of groundwater is recharging the aquifer as a result of percolation. The monthly rate of recycling varies between 8% to 28% at Faisalabad and 5% to 52% at Pindi Bhattian. This suggests that less groundwater can be pumped in February (Faisalabad), August and September (Pindi Bhattian). The net groundwater use in wheat-cotton system is with 19 cm for better than the 53 cm for rice-wheat systems.

SOIL MOISTURE STORAGE

The estimation of unsaturated soil moisture storage W_u is not straightforward from satellite imagery, as satellites cannot measure soil moisture content θ below the root zone. Field measurements of W_u for very large depths are practically cumbersome to achieve, especially under rice basins. Transient moisture profiles from SWAP have been used instead to get this daily information for larger depths. The results of the SWAP model has been used to develop a new simple parameterisation of matric pressure head distribution to calculate W_u in an alternative way. For this, the unsaturated zone is divided into two zones: 100 cm deep from the surface representing a root zone of constant depth and a variable intermediate zone i.e. between root zone and phreatic surface. In the root zone soil moisture storage W_{rz} can be obtained from satellite imagery with reasonable accuracy for large areas as demonstrated by Scot et al. (2002). Two conditions need to be considered with respect to phreatic surface: up to 750 cm and below 750 cm from ground surface. The areas where the phreatic surface is within 750 cm from ground surface, linear decrease in matric pressure head (h_m) is plausible from phreatic surface ($h_m=0$) to the bottom of root zone with maximum value of $h_m = -650$ when phreatic surface is at 750 cm. For very deep phreatic surface areas (greater than 750 cm), the intermediate zone is further sub-divided into two layers: one layer with a fixed depth of 650 cm above phreatic surface and one layer representing the remaining part. The depth of the upper part of intermediate zone is variable and equal to the difference between phreatic surface depth and 750 cm. In the lower layer of the intermediate zone, a linear decrease in absolute h_m is considered from phreatic surface, whereas in the upper part average value of h_m is calculated from h_m of the root zone and lower layer, which is -650 cm (as shown in Fig. 3).

Figure 3: Schematic diagram showing the new simple parameterisation scheme for matric pressure head distribution in the unsaturated zone.

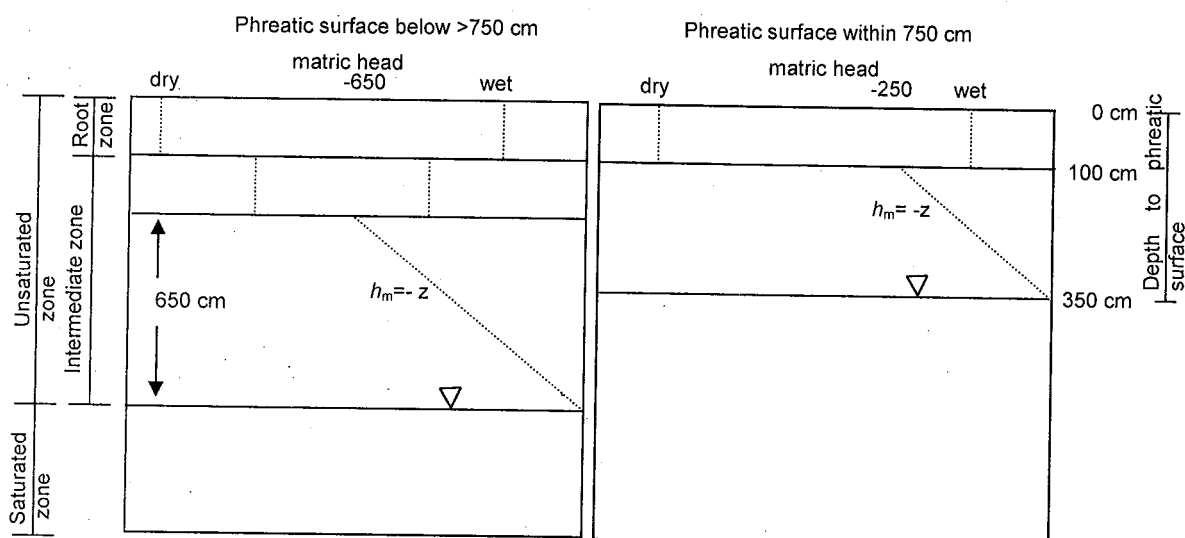

To verify the accuracy of the new simple parameterisation of matric pressure head distribution, daily model output of W_u from SWAP is compared with the result of the new parameterisation using soil moisture in the root zone and a value for the phreatic surface. A good agreement with an absolute RMSE of 7 cm is found. No systematic deviations between shallow and deep phreatic surface conditions were noticed (Ahmad and Bastiaanssen 2002).

For practical purposes, it is important to know the absolute error, which could occur at different levels of probability of exceedance. The absolute deviation in daily W_u of the new parameterisation from the SWAP model is computed for a year for both shallow and deep phreatic surface conditions and plotted against its probability of occurrence. The maximum error that could occur in W_u estimation is 18.24 cm d⁻¹ with the new parameterisation. However there are 85% chances that error in W_u estimation will be within the range of 0-10 cm d⁻¹. The average error is less than 5 cm d⁻¹.

REGIONAL SCALE METHODS AND RESULTS

In this study, the Surface Energy Balance Algorithm for Land (SEBAL) proposed by Bastiaanssen et al. (1998) is used for the computation of actual evapotranspiration ET_a in the study area. The annual period October 1993 to September 1994 was taken because additional water balance information was available for this period. NOAA AVHRR images covering the complete growing annual cycle (October 93 to September 1994) are processed surface albedo, solar radiation, the vegetation index and surface temperature. This data is applied to obtain radiation and energy balances at a spatial resolution of 1.1 km. Evapotranspiration is calculated from the instantaneous evaporative fraction, Λ , and the daily averaged net radiation, R_{n24} (Figure 4).

Validation in the Indus Basin was realized through a field scale transient moisture flow model, in situ Bowen ratio measurements and a water balance residual analyses for an area of 2.97 million ha of Rechna Doab. The accuracy of assessing time integrated actual evapotranspiration was found to vary from 0 % to 10 % at field scale to 5 % at the regional scale (Bastiaanssen et al. 2002b). The monthly ET_a in Rechna Doab is presented in Figure 5.

From these evaporative fraction maps Λ (latent heat flux/net available energy), the relative soil moisture content θ / θ_{sat} (-) in the root zone is computed for the Rechna Doab. The soils of the Rechna Doab are predominantly coarse to moderately coarse. An average value of θ_{sat} 0.35 cm³cm⁻³ is used to compute the root zone θ for all 18 images of Rechna Doab. The soil moisture storage in the root zone W_{rz} (cm) is determined from root zone θ considering a constant depth of 1 meter. Using the matric pressure head distribution approach explained in Fig. 3, soil moisture storage in complete unsaturated zone is obtained for the Rechna Doab (Figure 6).

Figure 4: Annual actual evapotranspiration (ET_a) for the Indus Basin: Year October 1993 to October 1994.

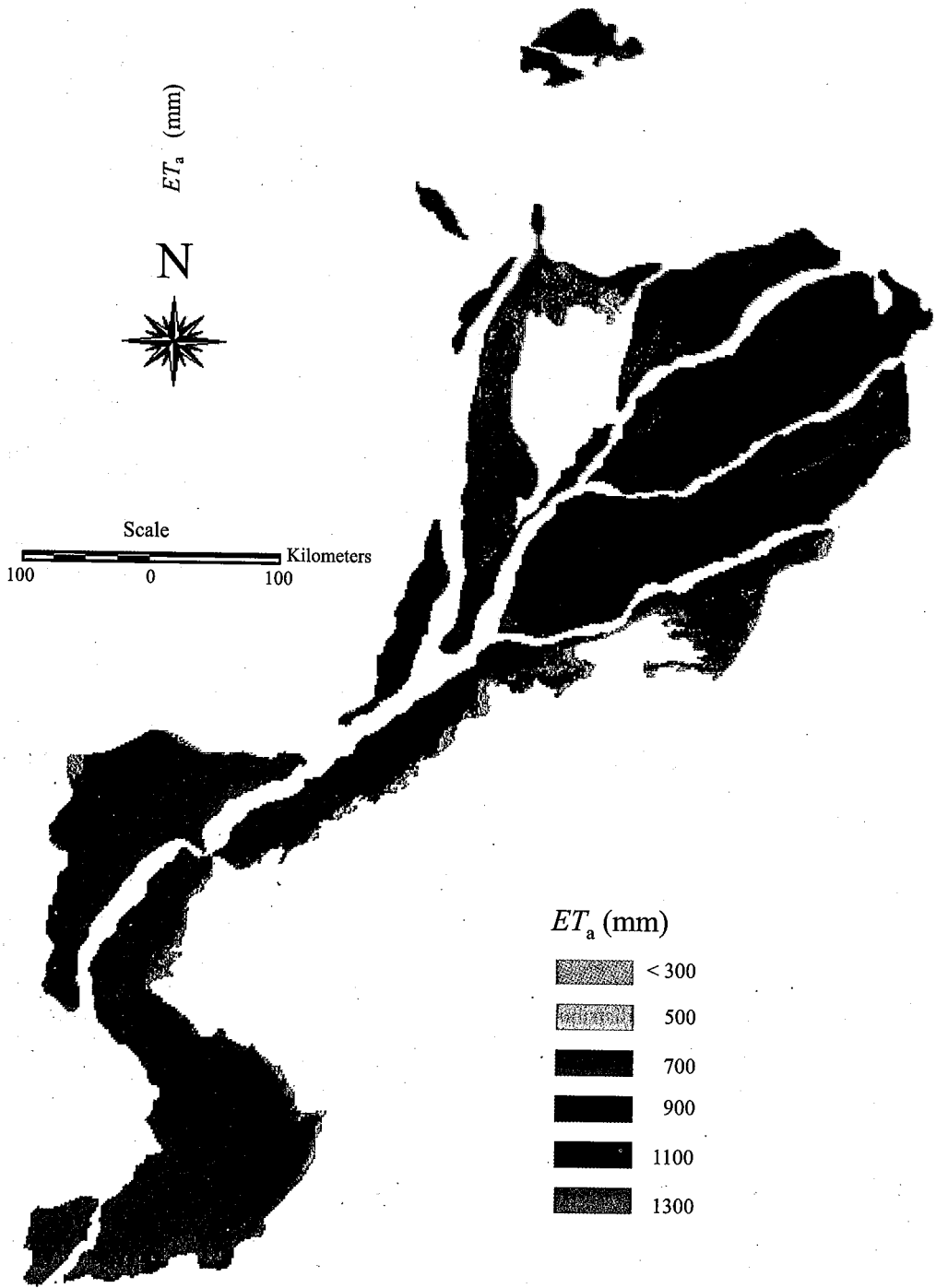

Figure 5: Monthly actual Evapotranspiration (ET_a) in the 2.97 million ha of Rechna Doab.

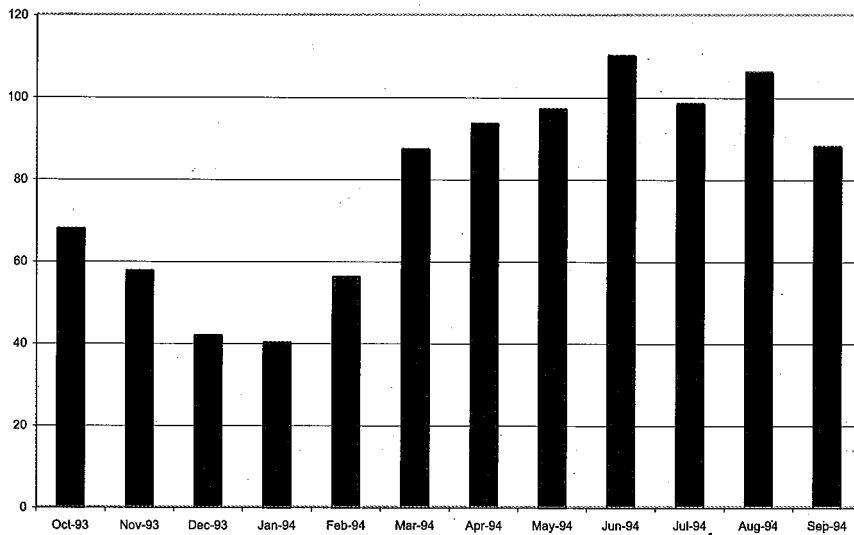
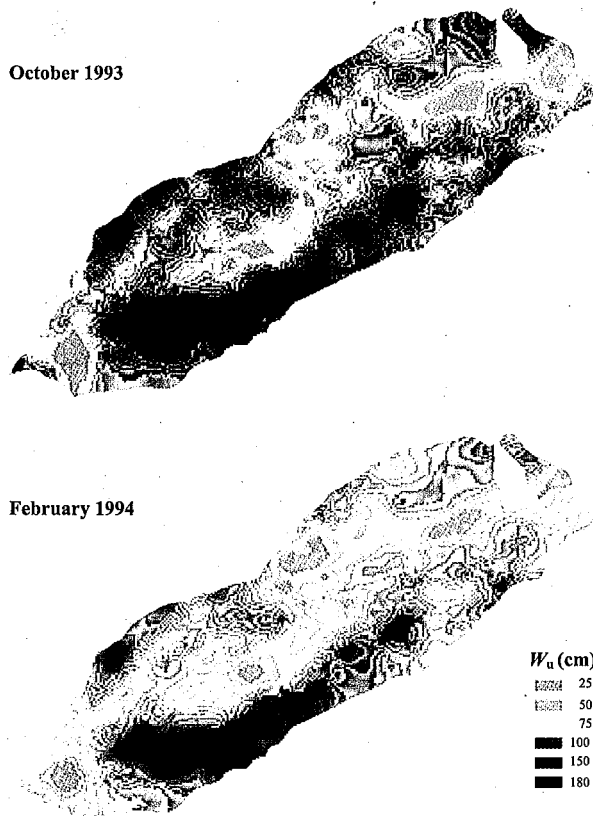

Figure 6: Spatial variation in soil moisture storage W_u of the entire unsaturated zone in the Rechna Doab.



The monthly changes in phreatic surface Δh and unsaturated soil moisture storage ΔW_u for shallow and deep phreatic surface areas are summarized for two locations in table 3. A considerable change in monthly W_u has been observed during May: result of end of *Rabi* and start of *Kharif* season.

Table 3: Monthly changes in phreatic surface and unsaturated zone storage in the shallow and deep phreatic surface areas in Rechna Doab.

Month	Shallow phreatic surface Pixel (100 ha) at latitude 73.32 longitude 31.78				Deep phreatic surface Pixel (100 ha) at latitude 72.59 longitude 30.90			
	Depth to phreatic surface (cm)	Change in phreatic surface (cm per month) Δh	Unsaturated zone storage (cm) W_u	Change in unsaturated zone storage (cm per month) ΔW_u	Depth to phreatic surface (cm)	Change in phreatic surface (cm per month) Δh	Unsaturated zone storage (cm) W_u	Change in unsaturated zone storage (cm per month) ΔW_u
Oct. 93	184.2		65.9		1040.5		154.4	
Nov. 93	191.3	7.1	64.6	-1.3	1030.8	-9.7	139.1	-15.3
Dec. 93	198.2	6.9	63.2	-1.4	1021.4	-9.4	129.2	-10.0
Jan. 94	205.4	7.1	57.5	-5.7	1011.7	-9.7	122.5	-6.7
Feb. 94	212.5	7.1	52.0	-5.5	1002.0	-9.7	115.7	-6.8
Mar. 94	218.9	6.4	51.7	-0.3	993.2	-8.8	131.5	15.8
April 94	226.0	7.1	71.5	19.8	983.5	-9.7	129.9	-1.6
May 94	232.9	6.9	58.8	-12.7	974.1	-9.4	96.1	-33.8
June 94	231.4	-1.6	65.4	6.6	959.4	-14.7	109.9	13.8
July 94	229.8	-1.5	65.7	0.3	945.2	-14.2	108.8	-1.0
Aug 94	228.2	-1.6	65.4	-0.3	930.4	-14.7	100.0	-8.9
Sep 94	226.7	-1.6	65.1	-0.3	915.7	-14.7	93.4	-6.6

The average change in phreatic surface and soil moisture storage for the 2.97 million ha area is presented in table 4. The change in soil moisture storage ΔW_u ranges between -12.1 to +7.1 cm month⁻¹ but cumulative change in storage is in the order of -8.06 cm from Oct. 93 to Sep 94 (table 4) thereby indicating that the phreatic surface is net rising. There are both negative and positive changes in monthly W_u for the Rechna Doab as one total system. The positive and negative variations in W_u are the result of rainfall and different irrigation and agronomic practices.

Table 4: Average monthly changes in phreatic surface and unsaturated zone soil moisture storage in the 2.97 million ha area of Rechna Doab.

Month	Depth to phreatic surface (cm)	Change in phreatic surface (cm month ⁻¹) Δh	Unsaturated zone storage (cm) W_u	Change in unsaturated zone storage (cm month ⁻¹) ΔW_u	Cumulative change in unsaturated zone storage (cm)
Oct. 93	464.3		93.6		
Nov. 93	472.8	8.4	91.4	-2.3	-2.3
Dec. 93	480.9	8.2	91.7	+0.3	-1.9
Jan. 94	489.3	8.4	88.3	-3.4	-5.4
Feb. 94	497.8	8.4	84.1	-4.2	-9.5
March 94	505.4	7.6	91.2	+7.1	-2.4
April 94	513.8	8.4	89.2	-2.1	-4.5
May 94	521.9	8.2	77.1	-12.1	-16.5
June 94	515.4	-6.6	83.9	+6.8	-9.7
July 94	509.0	-6.4	83.7	-0.2	-9.9
Aug 94	502.4	-6.6	84.5	+0.7	-9.2
Sep 94	495.8	-7.6	85.6	+1.1	-8.1

NET-GROUNDWATER USE

The fraction of irrigation with groundwater, which is not replenished by recharge is called as net groundwater use and can also be estimated as the residual of the soil water balance:

$$I_{ngw} * \Delta t = (ET_a - I_{cw} - P_n + \frac{\Delta W_u}{\Delta t}) * \Delta t$$

Using the spatial data seasonal and ignoring the precipitation interception losses, a net groundwater use I_{ngw} is estimated for selected canal commands in the Rechna Doab. The preliminary results are presented in Table 5. The higher values of net groundwater use during *Rabi* in the BRBD and UCC canal command is the result of non-perennial canals (i.e. less water is diverted from canal for irrigation).

Table 5: Seasonal net groundwater use in 4 selected canal command areas

Canal Command	Rabi 1993-94					Kharif 1994				
	P_n (mm)	I_{cw} (mm)	ET_a (mm)	W_u (mm)	I_{ngw} (mm)	P_n (mm)	I_{cw} (mm)	ET_a (mm)	W_u (mm)	I_{ngw} (mm)
Gugera	25	222	356	-49	60	270	338	604	-88	-92
Jhang	25	131	344	-52	136	284	119	565	-58	104
BRBD	53	24	345	-42	226	444	263	618	65	-24
UCC	26	55	346	-33	232	410	281	633	33	-25

Note: only +ive values of I_{ngw} represent net-groundwater use.

CONCLUSIONS

The aim of the present endeavour was to develop a methodology, which relies heavily on the use of remotely sensed information and geo-informatics techniques, to estimate net groundwater in large irrigated river basin.

Quantitative insight of field level water balance terms and water fluxes in the sub-soil, including groundwater recycling and changes in soil moisture storage in the unsaturated zone has been obtained using transient SWAP model. SWAP shows that a considerable fraction of groundwater irrigation is returning back to the same groundwater system in both the rice-wheat and cotton-wheat systems of Rechna Doab. Consequently, tubewells extractions do not give a good picture on the amount of groundwater extracted. Using SWAP results a new and simple parameterisation of matric pressure head distribution is developed which can estimate the unsaturated zone storage from root zone storage and depth to phreatic surface data with sufficient accuracy.

Seasonal and annual actual evapotranspiration and soil moisture storage is estimated using the satellite imagery. Seasonal and spatial variation in groundwater use in selected canal commands within Rechna Doab has been found. Net groundwater use in *Rabi* is much more than in *Kharif*, during which the aquifers are net recharged (except Jhang canal command area). This innovative approach can be applied in data scarce environment for better planning and management of conjunctive use.

REFERENCES

- Ahmad, M.D. and W.G.M. Bastiaanssen 2002, Retrieving soil moisture storage in the unsaturated zone from satellite imagery and bi-annual phreatic surface fluctuations. *Irrigation and Drainage Systems* (submitted).
- Ahmad, M.D., W.G.M. Bastiaanssen and R.A. Feddes 2002, Recycling and sustainable use of groundwater in irrigated fields: a numerical analysis of the subsoil water fluxes. *ICID Journal of Irrigation and Drainage*, John Wiley & Sons Ltd (submitted).
- Bastiaanssen, W.G.M., R. Singh, S. Kumar, J.K. Schakel and R.K. Jhorar 1996. *Analysis and recommendations for integrated on-farm water management in Haryana, India: a model approach*. Report 118. DLO Winand Staring Centre for Integrated Land, Soil and Water Research, Wageningen, The Netherlands. pp 152.
- Bastiaanssen, W.G.M., M. Menenti, R.A. Feddes and A.A.M. Holtslag, 1998. A remote sensing surface energy balance algorithm for land (SEBAL), part 1: formulation, *Journal of Hydrology*. 212-213: 198-212.
- Bastiaanssen, W.G.M., R. Saktivadivel and A. van Dellen, 1999. "Spatially delineating actual and relative evapotranspiration from remote sensing to assist spatial modeling of non-point source pollutants, in (eds.) Corwin et al."; *Assessment of non-point source pollution in the vadose zone*. *Geophysical Monograph 108*, American Geophysical Union: 179-196
- Bastiaanssen, W.G.M., M.D. Ahmad and Z. Tahir 2002a. Upscaling water productivity in irrigated agriculture using remote sensing and GIS technologies. Forthcoming proceeding of the *Water Productivity Workshop*. International Water Management Institute (IWMI), Colombo. Nov. 15-16, 2001.
- Bastiaanssen, W.G.M., M.D. Ahmad and Y. Chemin 2002b. Satellite surveillance of evaporative depletion across the Indus Basin. *Water Resources Research*, American Geophysical Union (submitted).
- Beekma, J., T.J. Kelleners, TH.M. Boers, M.R. Chaudhry and J.C. Van Dam, 1997. Recharge from irrigated lands. In: I. Simmers (Ed.), *Recharge of Phreatic Aquifers in (Semi-) Arid Areas*. A.A. Balkema, The Netherlands: 115-127.
- Bos, M.G. and J. Nugteren, 1974. On irrigation efficiencies, *International Institute for Land Reclamation and Improvement (ILRI)*, Wageningen, The Netherlands: 138 pp.
- Bos, M.G., D.H. Murray-Rust, D.J. Merrey, H.G. Johnson and W.B. Snellen, 1994. Methodologies for assessing performance of irrigation and drainage management; *Irrigation and Drainage Systems* 7: 231-261
- Burt, C.M., A.J. Clemmens, T.S. Strelkoff, K.H. Solomon, R.D. Bliesner, L.A. Hardy, T.A. Howell and D.E. Eisenhauer, 1997. Irrigation performance measures: efficiency and uniformity; *Journal of Irrigation and Drainage Engineering* 123(6): 423-442

- Clemmens, A.J. and C.M. Burt, 1997. Accuracy of irrigation efficiency estimates; *Journal of Irrigation and Drainage Engineering*, vol. 123(6): 443-453
- Clemmens, A.J. and M.G. Bos, 1990. Statistical methods for irrigation system delivery performance evaluation; *Irrigation and Drainage Systems* 4: 345-365
- Engman, E.T., and R.J. Gurney, 1991. Remote sensing in hydrology; Chapman and Hall, London
- Feddes, R.A., P. Kabat, P.J.T Van Bakel, J.J.B. Bronswijk and J. Halbertsma 1988. Modelling soil and water dynamics in the unsaturated zone—State of the Art. *Journal of Hydrology*, 100 (1988) 69-111.
- Food and Agricultural Organization of the United Nations, 1994. Water for life, *FAO*, Rome, Italy
- Guerra, L.C., S.I. Bhuiyan, T.P. Tuong and R. Barker, 1998. Producing more rice with less water from irrigated systems, *SWIM paper no. 5; International Water Management Institute*, Colombo, Sri Lanka.
- Jensen, M.E., 1977. Water conservation and irrigation systems: climate tech. sem. proc., Columbia, MO
- Kustas, W.P. and J.M. Norman, 1996. Use of remote sensing for evapotranspiration monitoring over land surfaces; *Hydr. Sci. J.* 41(4): 495-516
- Molden, D., 1997. Accounting for water use and productivity, *SWIM Paper 1; International Water Management Institute*, Colombo, Sri Lanka: 16 pp.
- Sarwar, A, W.G.M. Bastiaanssen, J.C. van Dam and M.Th. Boers, 2000. Evaluating drainage design parameters for the fourth drainage project, Pakistan by using SWAP model: Part I – calibration. *Irrigation and Drainage Systems*. 14, 257-280.
- Scott, C.A, W.G.M. Bastiaanssen and M.D. Ahmad, 2002. Mapping root zone soil moisture using remotely sensed optical imagery. *ASCE Irrigation and Drainage Engineering* (submitted).
- Smets, S.M.P., M. Kuper, J.C. Van Dam, R.A. Feddes, 1997, Salinization and crop transpiration of irrigated fields in Pakistan's Punjab. *Agr. Water Management* 35 (1997) 43-60.
- Van Dam, J.C. and R. A. Feddes, 1996. Modelling of water flow and solute transport for irrigation and drainage. In: L.S. Pereira et al., (Eds.), *Sustainability of Irrigated Agriculture*, Kluwer Academic Publishers, The Netherlands: 211-231.
- Van Dam, J.C., J. Hygen, J.G. Wesseling, R.A. Feddes, P. Kabat, P.E.V. van Walsum, P. Groenendijk and C.A. van Diepen, 1997. Simulation of water flow, solute transport and plant growth in the Soil-Water-Atmosphere-Plant Environment Theory of SWAP version 2.0. Report 71. Department of Water Resources, Wageningen Agricultural University, Technical Doc. 45 DLO Winand Staring Center, Wageningen. Agricultural University. 167pp.

Conjunctive Use of Water: Impact on Soil and Crops

Muhammad Ramzan Chaudhry¹ and Muhammad Nawaz Bhutta²

ABSTRACT:

The economy of Pakistan is closely linked with agriculture and about 75% population of the country is directly or indirectly dependent on agriculture. Half of the GNP also comes from this sector, but unfortunately, this sector is badly confronted with the problems of waterlogging, salinity/sodicity and inadequate availability of good quality irrigation water. The problems are not only affecting agriculture but they are also affecting the country as a whole and its people's socio-economic conditions.

To augment the inadequate water supplies of good quality water the only alternative is groundwater that is generally of poor quality, and as such its use may degrade the scarce land resources. To control the problems of waterlogging and salinity many Salinity Control and Reclamation Projects (SCARPs) were constructed by installing high capacity tubewells. The water quality of these tubewells varies considerably ranging from fresh to hazardous. The water of these tubewells was used in conjunction with canal water and the impact of this conjunctive use on soil, crops etc. was monitored regularly.

The salt affected (saline/sodic) area decreased in almost all the SCARPs due to additional groundwater supply and its conjunctive use with good quality canal water. This decrease in salinity/sodicity varied considerably in different SCARPs depending upon the extent of initial soil salinity/sodicity, volume of additional water provided through tubewell construction and the management practices adopted by the farming community. Waterlogging was also controlled significantly in the SCARPs area. The control in waterlogging and reduction in salt affected area due to SCARPs and conjunctive use of brackish drainage water has also resulted in the increase of crops yield and the improvement in the socio-economic status of the farmer communities. The gross value of production (GVP) of SCARPs has also been enhanced substantially. The results of research studies carried out in the farmers' field depicted the decrease in EC_e and SAR of soil when conjunctive use treatments were compared with pure tubewell water use treatment. The crop yield was not much affected with conjunctive use of water when compared with canal water irrigation treatment only. The conjunctive/cyclic use of brackish water can be adopted for bringing more area under cultivation for meeting the food and fiber requirements of the increasing population of the country.

¹ Director, IWASRI, Lahore

² Director General, IWASRI, Lahore

INTRODUCTION

Most of the productive area in the country falls in the arid and semi-arid climate. Rainfall is inadequate, uncertain, and scanty and is mostly during monsoon months (June September), which cannot be fully utilized. The success of agriculture is mainly dependant on irrigation through one of the biggest contiguous unlined irrigation systems, which due to excessive seepage resulted in the problem of waterlogging and salinity. During early sixties this problem became so serious that it was considered the top problem for the sustainability of irrigated agriculture in the country. To control this problem the Government of Pakistan launched Salinity Control and Reclamation Projects (SCARPs) by installing big capacity tubewells.

The quantity of good quality water is not sufficient to meet the crop water requirement and to augment this inadequate water supplies of good quality water the only alternative is groundwater. The quality of groundwater varies considerably ranging from fresh to highly saline. This water from the SCARPs tubewells was conjunctively used for irrigation purposes. The impact of tubewell water used in conjunction with canal water was monitored on soil salinity/sodicity, cropping intensities and crops yield. The main objective of this paper is to evaluate the impact of conjunctive use of water on soil properties and crop yield.

WATER RESOURCES

Most of the public tubewells, in fresh and marginal quality zone have been installed on the outlets in order to augment the inadequate water supplies. The water from tubewells mixes with canal water and then is used by the farmers. Some times, the farmers use even poor quality water to meet the crop water requirement. The availability of water from 1997-98 to 2002-3 is presented in Table 1.

Table 1: Water Availability from (1997-1998 to 2002-2003) at farmgate Million Acre Feet (MAF)

Source (K+R)	1997-98	1998-99	1999-2000	2000-2001	2001-2002	2002-2003	Increment
Surface Water	81.95	83.16	84.88	85.62	86.20	86.79	4.84
Groundwater	51.33	51.69	52.05	52.41	52.77	53.14	1.81
Total (S+G Water)	133.28	134.87	136.93	138.03	138.97	139.93	6.65

Reduction storage @ 0.15 MAF per year for Tarbela, Mangla and Chashma combined (2.25 MAF) / (One MAF = 1.234 BCM) Source: GOP, 1997.

GROUNDWATER QUALITY

In Pakistan a huge quantity of groundwater is available but its quality is highly variable in different parts of the country both vertically and horizontally, from completely fresh to extremely saline. Generally groundwater is fresh in strips along the rivers due to seepage of fresh water but deteriorated in the center of the Doabs.

The data presented in Table 2 depict that 49.4% area is with fresh groundwater, 11.8% is with marginal quality water and 38.8% is with hazardous water. The major part of the fresh and marginal water from the public tubewells is being used in conjunction with canal water.

Table 2: Groundwater Quality in Indus Plain

Province	Area underlain by different groundwater/salinity levels (Mha)			Total Area
	< 1500 mg/l	1500-3000 mg/l	> 3000 mg/l	
Punjab	6.84 (69%)	1.34 (14%)	1.66 (17%)	9.84
Sindh	0.94 (16%)	0.55 (9%)	4.46 (75%)	5.95
NWFP	0.35 (87%)	0.05 (13%)	-	0.40
Balochistan	-	-	0.28 (100%)	0.28
Total Area	8.13	1.94	6.40	16.47
% Area	49.4	11.8	38.8	

Source: Ahmed (1993) (Figures in parenthesis are percentages of the total)

LAND RESOURCES

Total geographical area of Pakistan is 79.61 mha and out of this area 59.28 mha during 1999-2000 falls under total reported area which is a sum of forest area, cultivated waste land, uncultivated area and the area under cultivation but not available (Table 3). The major cultivated and productive areas, in fact, lie in the Indus Basin.

Table 3: Land Use Statistics of Pakistan (area in Million Hectare)

Years	Geographical Area	Total reported Area (4+5+6+7)	Forest Area	Not Available for Cultivation	Cultural Waste	Cultivated Area col. (8+9)	Current Fallow	Net area	Area Sown More than Once	Total Cropped Area (9+10)	% Increase over 1971-72
1971-72	79.61	53.49	2.27	20.43	11.25	19.09	4.75	14.34	2.26	16.60	-
1975-76	79.61	53.92	2.84	20.63	10.62	19.83	4.77	15.06	2.96	18.02	9
1979-80	79.61	55.09	2.84	21.02	11.93	20.30	4.82	15.48	3.32	18.80	13
1985-86	79.61	57.59	3.12	24.52	9.47	20.68	4.91	15.77	4.51	20.28	22
1990-91	79.61	57.61	3.46	24.34	8.85	20.96	4.85	16.11	5.71	21.82	32
1994-95	79.61	58.50	3.60	24.44	8.91	21.55	5.42	16.13	6.01	22.14	33
1997-98	79.61	59.32	3.59	24.55	9.14	22.04	5.35	16.69	6.35	23.04	39
1999-00	79.61	59.28	3.66	24.50	9.13	21.99	5.67	16.32	6.44	22.76	37

Source: GOP, (1980 and 2000)

The total cropped area, either irrigated or barani, in Pakistan constitute 16.60 mha during 1971-72, which has increased up to 22.76 mha during 1999-2000. Similarly, the area under forest has increased from 2.27 mha during 19971-72 to 3.66 mha during 1999-2000. However, the culturable waste has been reduced from 11.25 mha to 9.13 mha during the same period of time. The increase in the total cropped area and percent increase over 1971-72 is presented in Figure-1.

Figure 1: Total Cropped Area and Percent Increase Over 1971-72 of Pakistan.

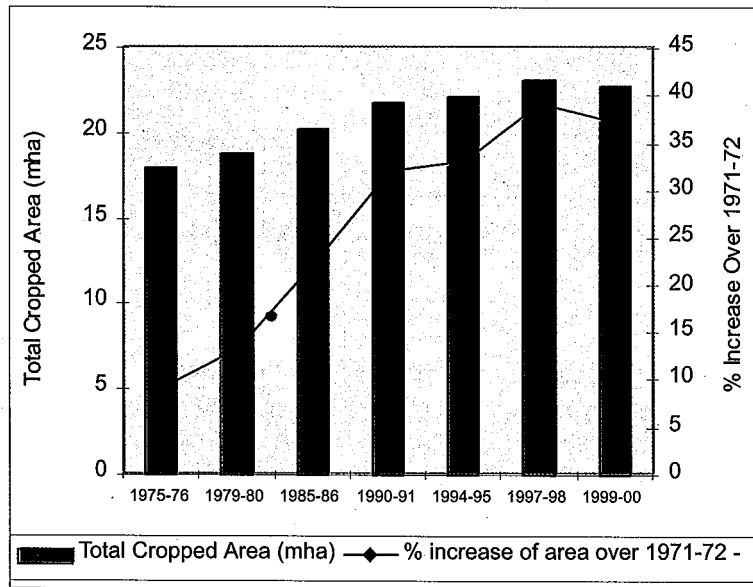

5. WATERLOGGING PROBLEM

The flat topography, seepage from the canal system, poor water management practices, inadequate provision of drainage and poor operation, and maintenance of the irrigation and drainage systems resulted in severe problem of waterlogging. From 1978 to 2000, the area under less than 1.5 m watertable ranged between 3.3 to 18.3%. Similar variations were also observed in watertable between 1.5 to 3.0 m and greater than 3.0 m area. It is clear from the data present in Figure. 2 that during 2000, the area under less than 1.5 m depth to watertable is only 3.3% which is due to dry spell and less canal water supplies.

Figure 2: Area (%) Under Different Watertable Depths (April – June)

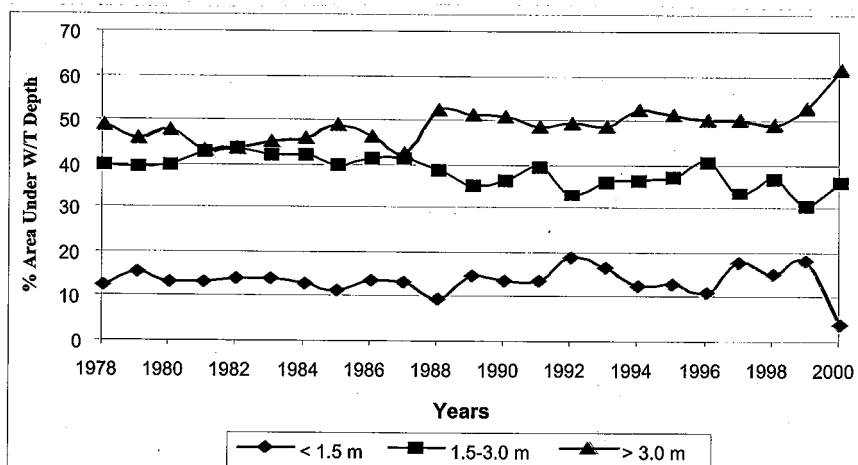

SALINITY/SODICITY PROBLEM

The first salinity survey was conducted during 1953-75 and the second one during 1977-79 in Pakistan. The extent of salinity/sodicity is briefly described as under:-

Surface Salinity

The survey conducted by WAPDA during 1977-1979, brought out the true status of soil salinity in the canal commands. This survey, indicated that in terms of slightly, moderately, and strongly saline soils, about 25 percent of the area (16.72 mha) is affected by surface salinity. The province-wise position of surface salinity in the country is presented in Table 4. Comparison with past survey has indicated that the land affected by surface salinity has decreased from 42% in the early 60s to about 25% in 1977-79. This reduction in surface salinity was primarily due to increased irrigation water supply from surface and groundwater sources, its conjunctive/cyclic use and other measures taken. A contributory factor to this reduction may also be the incidence of exceptional rainfall during 1973-75, a few years before the survey.

Table 4: Province-wise Surface Salinity Status (% of area surveyed/16.72 mha)

Province	Survey Period	Salt Free S1	Slightly Saline S2	Moderately Saline S3	Strongly Saline S4
N.W.F.P.	1977-79	78	8	2	2
	1971-75	75	10	4	2
Punjab	1977-79	84	7	4	3
	1953-65	72	15	5	6
Sindh	1977-79	50	19	10	18
	1953-54	26	28	17	27
Balochistan	1977-79	74	17	5	4
	1953-54	69	15	7	9
Pakistan	1977-79	72	11	6	8
	1953-75	56	20	9	13

Source: WAPDA (1980)

Profile Salinity/Sodicity (Chemical Status)

The non-saline non-sodic (normal), saline, saline sodic and sodic soils were 55, 6, 27 and 11% according to the survey of 1962-65 but these were 61, 11, 24, 3%, respectively during the later survey of 1977-79 indicating the overall improvement in salt-affected area (Table 5). It is evident from the data that most serious problem of profile salinity/sodicity exists in Sindh province followed by Punjab. A soil salinity survey is being carried out under National Drainage Program, which will show the latest status of soil salinity/sodicity in the country.

Table 5: Province-wise Chemical Status of Soil Profiles (% of Profiles)

Province	Survey Period	No. of Profiles	NSNS*	Saline	Saline Sodic	NSS**
N.W.F.P.	1977-79	1958	79	11	7	2
	1971-75	314	27	50	23	-
Punjab	1977-79	39963	73	7	14	5
	1962-65	23662	55	6	27	11
Sindh	1977-79	20543	38	17	42	2
Balochistan	1977-79	1402	35	26	38	1
Pakistan	1977-79	63866	61	11	24	3
	1962-65	23976	55	6	27	11

* Non-Saline Non-Sodic ** Non-Saline Sodic
Source: WAPDA (1980)

CONJUNCTIVE USE/SCARPS IMPACT

The impact of Salinity Control and Reclamation Projects and conjunctive use was considerably significant. However, specifically, impact of SCARPs/ conjunctive use on waterlogging, salinity/sodicity and improvement in the socio-economic conditions of the people of some of the SCARPs is discussed as under:

Waterlogging

A network of 5000 observation points has been established in irrigated areas of Pakistan by SMO, WAPDA to monitor the behavior of watertable. The effect of SCARPs/Conjunctive use of water on ground watertable is given in Table 6 indicating reduction in waterlogged area.

Table 6: Impact of SCARPs/Conjunctive Use on Waterlogging

SCARP	Total Area (000 ha.)	Pre-Project			Post-project							
		Year	Area	%age	1987		1988		1989		1998	
					Area	%age	Area	%age	Area	%age	Area	%age
I	493	1961	66.4	13.5	10.5	2.2	2.0	0.4	6.9	1.4	1.2	0.3
II	667	1964	73.2	11.0	47.4	7.1	8.0	1.2	34.0	5.1	32.0	4.8
III	461	1969	189.9	41.0	106.0	23.0	69.0	15.0	119.4	25.9	119.0	25.8
Khairpur	154	1960	45.7	29.7	68.1	44.2	32.8	21.3	52.4	34.0	32.5	21.1
N. Rohri	278	1966	30.6	11.0	10.8	3.9	17.2	6.2	15.6	5.6	27.2	9.8
Fourth Drainage Project, Faisalabad	143	1985	42.9	30.0	-	-	-	-	-	-	32.9	23.0

Source: SMO, (1994) and SMO, (1998 Unpublished).

Soil Salinity/Sodicity

The data presented in Table 7 depict that soil environment has been improved with the reduction of soil salinity at the surface as well as in the profile. The extent of reduction in surface and profile salinity was different but in almost all the SCARPs this surface/profile salinity was considerably decreased.

Table 7: Impact of SCARPs/Conjunctive Use of Water on Surface and Profile Salinity

SCARPs	Surface salinity (% of area)				Profile salinity (% of profiles)			
I	34 (1962-65)	12 (1977-79)	23 (1981-82)	15 (1986-88)	59 (1962-63)	28 (1977-78)	39 (1981-82)	37 (1986-88)
II	44 (1962-65)	22 (1977-79)	12 (1983-85)	-	42 (1962-63)	22 (1977-80)	21 (1983-85)	-
III	35 (1953-65)	14 (1977-80)	12 (1982-83)	-	51 (1962-65)	28 (1977-78)	36 (1982-83)	-
IV	63 (1953-65)	30 (1976-80)	23 (1986-87)	-	75 (1962-65)	37 (1977-78)	37 (1986-87)	-
Fourth Drainage Project, Faisalabad	44 (1985)	31 (1990)	-	-	50 (1985)	39 (1990)	-	-

Source: Pakistan ICID Country Report, (1991) and SMO, (1994 and 1998)

Socio-economic Impacts

The socio-economic status of the farmers' communities has tremendously improved due to waterlogging and salinity remedial measures. Farmers are getting more return from their lands. Increase in gross value of production (GVP) for some selected SCARPs is provided in Table 8. The data showed that the construction of these projects has enhanced the GVP of the project substantially, and consequently, the socio-economic status of the farming community and allied people has been improved. The graphical presentation of increase in gross value of production is shown in Figure 3.

Table 8: Impact of SCARPs/Conjunctive Use of Water on Gross Value of Production (M.Rs.)

SCARP/Base year	Pre-project	Achieved		% Increase in 1988-89 over Base Year
I (1959-60)	191	452 (1987-88)	476 (1988-89)	149
II (1964)	462	816 (1987-88)	841 (1988-89)	82
III (1969)	181	444 (1987-88)	444 (1988-89)	145
IV (1968-69)	93	225 (1987-88)	208 (1988-89)	124
Khairpur (1966-67)	91	164 (1987-88)	162 (1988-89)	78
North Rohri (1972-73)	319	650 (1987-88)	684 (1988-89)	114

Source: Pakistan National Commission of ICID, (1991)

Figure 3: Impact of SCARPs/Conjunctive Use of Water on Gross Value of Production.

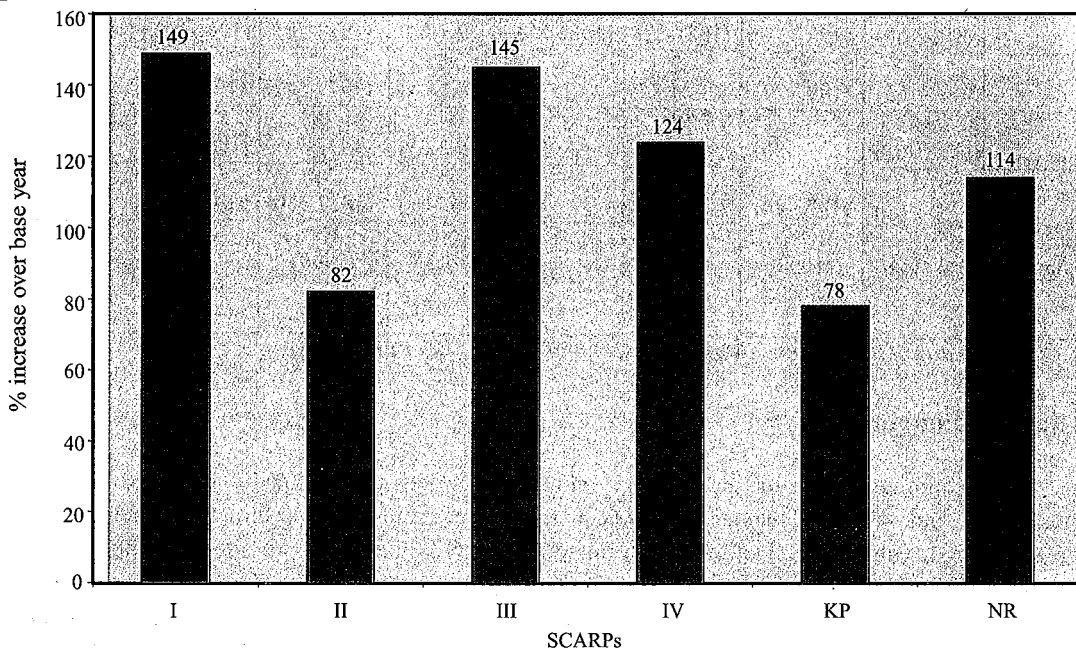

EFFECT OF CONJUNCTIVE USE OF WATER IN COMPARISON WITH OTHER TREATMENTS

The effect of conjunctive use of saline water with canal water in comparison with other treatments on soil properties and crop yield is discussed as under:

Effect on Salinity (EC) and Sodicity (SAR) of soil

The effect of different treatments on the EC_e and SAR of soil is presented below:-

Salinity of Soil (0-15 cm)

Data presented in Table-9 showed that with the exception of the plots irrigated with undiluted tubewell water, the EC_e decreased significantly after a period of three years. The EC_e measurements at the end of the experiment (S7) compared to those taken initially showed reductions of 67, 48, 55, 38 and 47 percent in treatments 1, 2, 3, 4 and 5, respectively. Such reductions were due to the combined leaching effects of scattered rainfall (155 cms) and irrigation applications (369 cms). Where only canal water was used for irrigated, the EC_e was reduced by 67 percent. Contrarily, an increase of 18% was observed where pure tubewell water was applied for irrigation. A considerable reduction was observed where saline water was used in conjunction with canal water or cyclic use was adopted.

Table 9: Effect of Different Treatments on EC_e of 0-15 cm Soil Depth

Treatments	Pre-Wheat 1989-90 S-1	Post Wheat 1989- 90 S-2	Post Rice 1990 S-3	Post Wheat 1990-91 S-4	Post Rice 1991 S-5	Post Wheat 1991-92 S-6	Post Rice 1992 S-7	Mean	% decrease/ Increase in S-7 over S-1
T1 Canal Water	5.5	4.3	3.1	3.3	2.3	3.2	1.8	3.4	-67
T2 Alternate irrigation with canal water and T/Well Water	4.2	3.5	3.3	3.4	2.8	3.2	2.2	3.2	-48
T3 Canal and T/Well Water (1:1)	5.5	5.2	3.2	3.8	2.9	2.8	2.5	3.7	-55
T4 First irrigation with canal water and later irrigations with saline water	5.3	4.7	3.2	3.6	3.0	3.5	3.3	3.8	-38
T5 Canal and T/Well Water (1:3)	6.0	6.1	3.2	4.0	3.4	3.5	3.2	4.2	-47
T6 Tubewell Water	3.4	4.2	3.9	4.1	3.6	3.6	4.0	3.8	+18
Mean	4.98 (a)	4.67 (a)	3.32 (b)	3.7 (b)	3.0 (b)	3.3 (b)	2.83 (b)	-	

LSD (samplings) 1% = 0.93

Mean followed by different letters differ significantly.

Source: Sidhu et al. (1996)

In all cases except the tubewells irrigated plot which initially had the lowest soil salinity than the plots under all the other treatments, the most significant reduction in EC_e occurred up to the first post-rice sampling (S3) i.e. within about one year period. The results clearly indicate the importance of leaching by growing a high delta rice crop.

Sodium Adsorption Ratio of Soil (0-15 cm depth)

There was no significant effect of different irrigation treatments on the SAR of soil. However, a reduction of 43, 35, 41, 34, 31 and 6 percent in Treatments 1, 2, 3, 4, 5 and 6 respectively over a three-year period was observed (Table-10). Treatments 1 and 3 showed the best improvement where canal water and canal plus tubewell water in the ratio of 1:1 was applied. However, the initial SAR in Treatment-3 was higher than all others, as expected to show a proportionally larger reduction than Treatments 2, 4, 5 and 6. Application of good quality water reduced soil SAR considerably. The SAR decreased slightly also in Treatment 6 where pure tubewell water was applied. Under the conditions of continuous irrigation with tubewell water, a gradual increase in SAR would be expected; however, the canal water application to the rice crop has provided sufficient leaching to prevent the sodicity build-up and the addition was not sustainable. The SAR was significantly affected during different sampling periods. The SAR was significantly higher in Sampling 1 and 2 as compared to the SAR of other samplings. The minimum SAR of 7.1 was observed in Sampling 5. At the final sampling the SAR again increased which may be due to high watertable (1.25 m) and evaporative conditions under the wheat crop. A sharp reduction in the SAR of soil was observed during rice 1990.

Table 10: Effect of Different Treatments on SAR of 0-15 cm Soil Depth

Treatments	Pre-Wheat 1989-90 S-1	Post Wheat 1989-90 S-2	Post Rice 1990 S-3	Post Wheat 1990-91 S-4	Post Rice 1991 S-5	Post Wheat 1991-92 S-6	Post Rice 1992 S-7	Mean	% decrease/ Increase in S-7 over S-1
T1 Canal Water	14.8	13.8	8.5	9.0	5.1	8.7	8.5	9.77	-43
T2 Alternate irrigation with canal water and T/Well Water	13.9	13.4	9.0	10.2	7.2	9.9	9.0	10.37	-35
T3 Canal and T/Well Water (1:1)	15.7	14.8	9.2	9.9	7.6	9.7	9.3	10.88	-41
T4 First irrigation with canal water and later irrigations with saline water	14.2	13.5	9.2	9.8	8.0	8.7	9.4	10.40	-34
T5 Canal and T/Well Water (1:3)	13.7	13.9	9.6	10.5	7.1	9.9	9.5	10.60	-31
T6 Tubewell Water	11.2	13.2	11.1	12.9	11.7	9.2	10.5	11.40	-6
Mean	13.92 (a)	13.77 (a)	9.43 (b)	10.38 (b)	7.78 (b)	9.35 (b)	9.37 (b)	-	

LSD (samplings) 1% = 0.93

Mean followed by different letters differ significantly.

Source: Sidhu et al. (1996)

EFFECT ON CROP YIELD

Wheat and rice crops were harvested on the whole plot basis, threshed and weighed separately to assess crop production, and the treatment effects are discussed as below:

Wheat Grains Yield

Wheat grain yield was affected significantly by various irrigation treatments (Table-11). Maximum average wheat grain yield of 3815 kg ha⁻¹ was recorded in Treatment 1 where all irrigations were applied with canal water, which was significantly higher than the yield obtained in Treatments 6. The difference among the first four treatments was non significant. On an average, the minimum yield of 3139 kg ha⁻¹ was recorded in Treatment 6 where tubewell water was used. Low grain yield in Treatment 6 where tubewell water was applied is attributed to the salt additions through saline irrigations (Figure-4). Wheat grain yield differed significantly season-wise. It was the highest during 1989-90 and then reduced during subsequent years. Reduction may be due to seasonal variation, insufficient NPK or plant water stress between irrigations at critical physiological stages of growth.

There was 13% reduction in wheat grain yield during 1990-91 and 21% reduction during 1991-92 over 1989-90.

Table 11 Effects of Different Treatments on Wheat Grain Yield (kg ha^{-1})

Treatments	1989-90	1990-91	1991-92	Mean	% decrease over T-1
T1 Canal Water	4142	3694	3610	3815 (a)	-
T2 Alternate irrigation with Canal and Tubewell Water	4036	3422	3163	3541 (ab)	-7
T3 Canal and Tubewell Water (1:1)	3993	3438	3146	3526 (ab)	-8
T4 First irrigation with canal water and later irrigations with saline water	3993	3553	3094	3480 (abc)	-9
T5 Canal and T/Well water (1:3)	3773	3388	3116	3426 (bc)	-10
T6	3741	3207	2470	3139 (c)	-18
Mean	3946 (a)	3417 (b)	3100 (c)	-	-
% Decrease over 1989-90		-13	-21	-	-

LSD (Treatments) 5% = 367.80 *LSD (Years) 5% = 260.08*

Means followed by different letters differ significantly.

Source: Sidhu et al. (1996)

Figure 4: Effects of Different Treatments, on an Average, on Wheat Grains Yield.

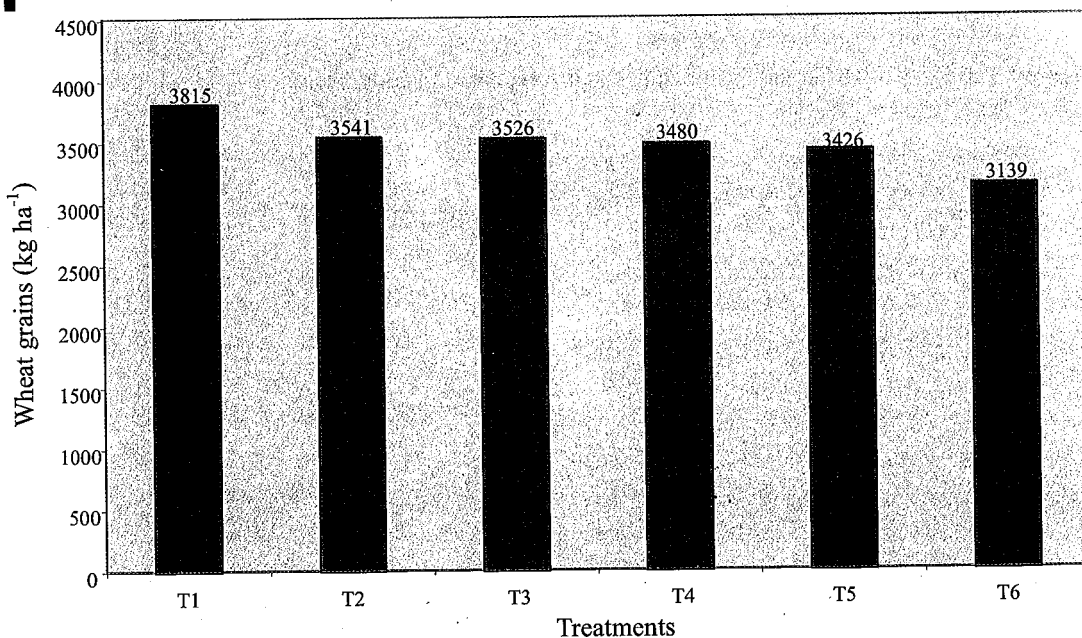

Paddy Yield

The paddy yield was also affected significantly with different treatments and the yield obtained in Treatments 1 and 2 was significantly higher as compared to the yield of Treatments 5 and 6, but based on the percent decrease there was not much reduction in paddy yield (Table. 12). On an

average, the highest yield of 1949 kg ha⁻¹ was found in Treatments 2, where alternate irrigations with fresh and saline water were applied (Figure 5) but it did not differ significantly from Treatment 1 where canal water was applied.

Paddy yield also differed significantly between seasons. In the first season the yield was higher compared to the following two other Kharif seasons. The data further revealed that there was 35% decrease in paddy yield during 1991 over 1990 and 23 % during 1992. This was possibly due to timely non-availability of adequate canal irrigation water and salt accumulation in the soil.

Table 12: Effects of Different Treatments on Paddy Yield (kg ha⁻¹)

Treatments	1989-90	1990-91	1991-92	Mean	% decrease over T-1
T1 Canal Water	2349	1548	1848	1921 (ab)	-
T2 Alternate irrigation with canal and Tubewell Water	2447	1553	1848	1949 (a)	+1
T3 Canal and Tube/well Water (1:1)	2287	1492	1799	1859 (bc)	-3
T4 First irrigation with canal water and later irrigations with saline water	2312	1512	1826	1883 (abc)	-2
T5 Canal and T/Well water (1:3)	2291	1466	1727	1828 (c)	-5
T6	2312	1523	1705	1847 (c)	-4
Mean	2333 (a)	1516(b)	1795 (b)	-	-
% Reduction over 1989-90		-35	-23	-	-

LSD (Treatments) 5% = 65.50

LSD (Years) 1% = 65.88

Means followed by different letters differ significantly.

Source: Sidhu et al. (1996)

Figure.5: Effects of Different Treatments, on an Average, on Paddy Yield.

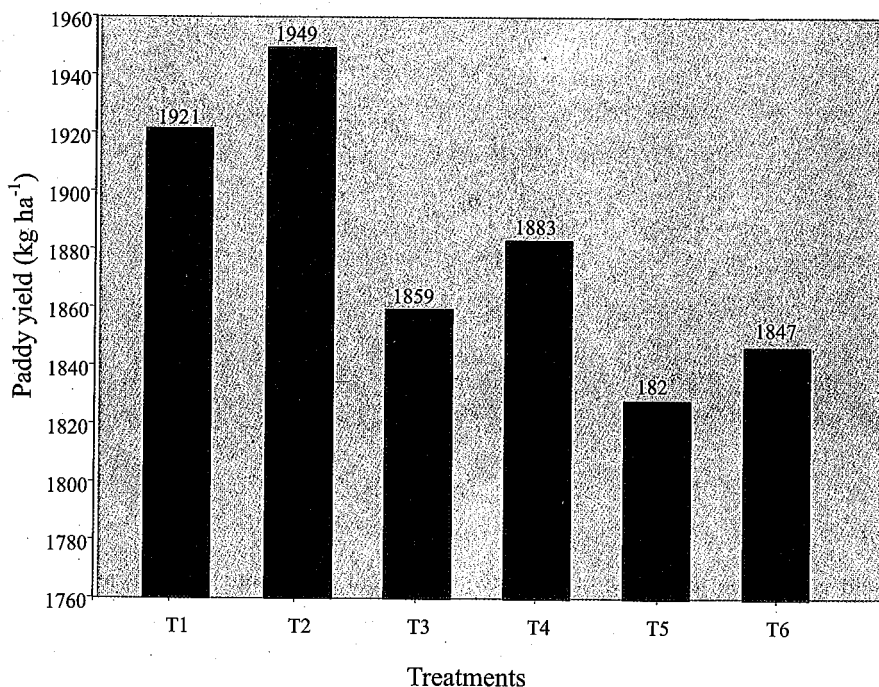

CONCLUSIONS

- Conjunctive use of water in SCARPs resulted in the decrease of soil salinity/sodicity.
- Installation of public and private tubewells helped in controlling waterlogging.
- Gross value of production significantly increased with conjunctive use of water/SCARPs.
- Conjunctive use of canal and T/Well water in 1:1 and even 1:3 ratios reduced the soil salinity/sodicity of upper 15 cm soil considerably.
- Slight decrease in wheat grains and paddy yield was observed with the conjunctive use of canal and brackish tubewell water compared with canal water.

RECOMMENDATIONS

- If need prevails for use of brackish water it should be applied in conjunction with good quality water or its cyclic use be adopted.
- High sodic water should only be applied after amending with some proper treatment/ amendment.
- Available technology, in simple language, should be transferred to end users especially the farmers.
- Experiments should be conducted under different soil and climatic conditions to have technology for site-specific conditions in the country.

REFERENCE

- Ahmed, N.1993. Water Resources of Pakistan. Published by Shahzad Nazir, 61-B/2, Gulberg III, Lahore.
- Chaudhry, M.R; A. Hameed; M.A Chaudhry and M.Q. Channa.1997. Soil properties and crops yield as affected by drainage water and management. proc.Int. Sym. Water for the 21st Century: Demand, Supply, Development and Socio-environmental Issues, from June 17-19, 1997, CEWRE, Lahore: 403-409.
- GOP. 1980. Agricultural Statistics of Pakistan 1980, Govt. of Pakistan, Ministry of Food, Agriculture and Cooperatives, Food and Agriculture Division (Planning Unit) Islamabad: pp. 372.
- GOP.1997. Ninth Five Year Plan (1998-2003) Report of the working group on Water Resources Development, Vol.1, Main Report, Govt. of Pakistan, Planning Commission, Islamabad, pp-65.
- GOP. 2000. Agricultural Statistics of Pakistan 1999-2000. Govt. of Pakistan, Ministry of Food, Agriculture and Livestock, Food, Agriculture and Livestock Division (Economic Wing), Islamabad. PP: 302.
- Pakistan National Commission of ICID. 1991. Irrigation and drainage development in Pakistan. Country Report. Asia Year 1991.
- Sidhu, M; M.R.Chaudhry and Ihsanullah.1996. Conjunctive use of fresh and saline water for irrigation . IWASRI Publ. No.168, pp-58.
- SMO. 1994. Summary evaluation and monitoring statistics of SCARPs (1987-88 and 1998-89). SCARPs Monitoring Organization, Canal Bank, Moghalpura, Lahore. Publ. No.SM-232, PP.291.
- WAPDA. 1980. Soil Salinity Survey, Data Reports, Planning Division, WAPDA, Lahore.
- WAPDA.1981. Soil Salinity Survey Vol.II.S&R Organization, Planning Division, WAPDA Lahore.

Part IV

Economical/Institutional Aspects of Conjunctive Water Management

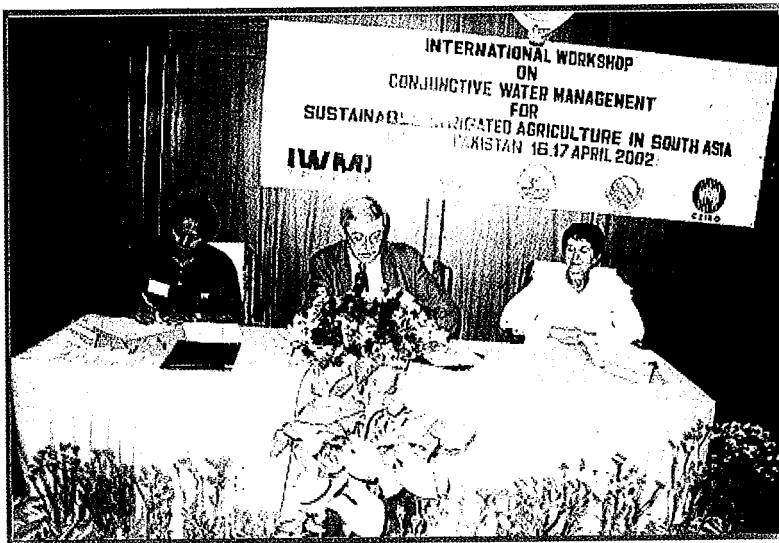

Dr. Hammond Murray-Rust, (center), Chairman of the Session
Ms. Vilma Horinkova, (right), Keynote Speaker
Dr. Muhammad Aslam, (left), Rapporteur

Water Institutional Arrangements Under Water Scarcity

Vilma Horinkova¹

THE VALUE OF WATER

Water means life. If we take a historical view of use of water, we can see that water was always connected to the religion – it “came from God” and its use was free. Anybody had a right to water and could use as much of it as needed if it was available. Individuals in communities were taking turns and used river water as a run of the river for irrigation, sharing the high and low flows in rotation. This took place without any written rules or laws.

With technological and economic development towards the end of 20th century water started to change its value, often leading to competition between different sectors of the economy that used water as well as amongst water users in agriculture. As such, water had changed its value and became a commodity, with an economic value and a price attached to it. Societies started to develop rules and laws for different types of water use, assigning priorities for its allocation. During the nineties, and somewhat under pressure of the multilateral donors for privatization, water became a tradable, profitable economic good, to be marketed, exploited (and at times overexploited) by those who could afford to pay for it. The trend towards privatization in water and irrigation sector increased the price of water, therefore, making fresh drinking water less accessible to the world poor, causing the poverty levels dramatically increased. Globally, the projections show that by 2010 there will be 2.5 billion of people lacking access to safe drinking water.

With the world population growing, industrialization increasing and areas of irrigated agriculture expanding, water sources in many countries have become polluted affecting millions of people's lives. Water resources have become scarce and quality of both groundwater and surface water seriously impacted. Competition for water between uses and users has led in some areas of the world to disputes and conflicts, making water definitely a matter of political choices and debates. This is markedly evident in basins concerning trans-boundary waters, where water needs for economic development of each country must be harmonized with the environmental needs of the region or basin.

WATER SCARCITY AND CONJUNCTIVE WATER MANAGEMENT

Water scarcity, either permanent or seasonal, exists when the country water resources base cannot satisfy the multiple needs of the population for domestic use, industry and agriculture as well as the environment. The scarcity can be caused not only by natural phenomena, such as an inadequate

¹ Director, IWMI Central Asia and Caucasus Office

rainfall, low snowfall and snowmelt, but could also be induced by human activities and actions resulting from institutional problems and mismanagement. Therefore, from time to time, the link between water demands and the country water resources base spawns a need for changes and reforms in the water institutional arrangements even in the well-developed countries. Such changes embody the necessary institutional adjustments, so that an adequate amount of water is made available for agriculture to produce food for growing population and for sustaining of quality environment.

Problems with water quantity and quality have become the key global issues in water management during the last decade and they are expected to continue for decades to come. Countries are finding their own ways of how to cope with the scarcity of water resources, resorting to different strategies for changes in their water institutions³, applying innovative technologies and techniques, adopting new laws and regulations, privatizing services and making organizational changes. There are no blue prints for perfect institutional arrangements, but there are guiding principles that are applicable to make the regulation and operation of the water sector most effective for each particular situation.

One of the best ways to address the needs of the ever-increasing population and associated demand for food is to utilize all available sources that are acceptable in water quality, and practice conjunctive⁴ water management for irrigation (CWM). The CWM refers to the management of water resources and water sources, generally at the basin scale. The water sources may include all types of water sources - rivers, dams, canals, groundwater, surface runoff, agricultural drainage, municipal sewage, and industrial effluent. Naturally, such an approach places high demand on the legal and regulatory framework for water allocation, development of planning and operational policies and design of suitable organizational arrangements. In other words, the CWM or integrated water resource management (IWRM) should support a prudent use of all water sources and water resources to secure food and enhance environmental sustainability. The basic tenet germane to the IWRM or CWM can be described below as:

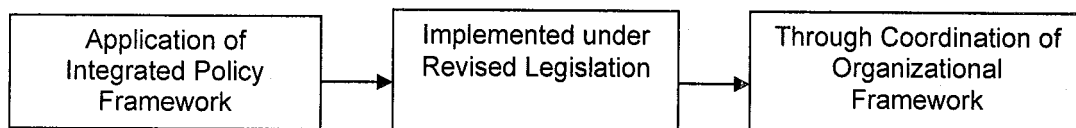

The principle of CWM lies in adopting institutional changes coupled with technical innovations, to minimize the negative impacts (e.g., salinity, water logging, pollution of aquifers) by utilizing research methods, new approaches and concepts for management. It can be said that the conjunctive water management is relatively simple in theory but difficult in practice.

REFORMS IN INSTITUTIONAL ARRANGEMENTS

The major institutional changes in water resource management envisaged would be leading towards IWRM or CWM and would constitute reforms in sectoral allocation of surface and groundwater,

³Under water institutions, in the broad sense, we understand not only organizations, agencies, and entities involved in some way in water resources management, but also formal arrangements and instruments such as laws, rules, regulations, written agreements, as well as informal mechanisms (traditions, religious or ethnic, or community customs), as they all comprehensively contribute to the way water is managed.

⁴The term 'conjunctive' water management can also be understood in a broader context as integrated or comprehensive water resources management and in this paper it will be used interchangeably.

which is generally embodied in the supporting legal and regulatory framework. The reforms would also include the setting up of an effective water rights system that is equitable and flexible and encompasses all water sources. Reforms are also needed when the infrastructure is deteriorated and gaps in the organizational aspects for water use planning, delivery, and distribution exist. The problems with infrastructure and water quality and quantity, as well as minimizing negative impacts of soil salinity and water logging present enormous challenges for the water users, managers and indirectly for all water stakeholders.

Besides the formal institutional arrangements concerning primarily the legal and regulatory framework and policies, there are the informal arrangements that help to accomplish various water management processes; these can be traditions, religious customs and cultural norms – being often a strong catalyst for program implementation. Similar to the outcome of informal arrangements, the concept of participation of key water stakeholders has been regarded as an effective means for making changes more sustainable. Such a participatory process may take on a variety of forms – meetings, workshops, informal gatherings, committees, and public media. For the best, it should be considered at all levels of the system – local, regional (basin), and national (federal).

The integrated framework of policies and legislative instruments need to reflect the growing demand for water, securing the water supply from variety of sources, meeting the operational demand and the costs of water delivery, distribution and maintenance, and assuring equity in water distribution.

PAKISTANI SYSTEM – RECHNA DOAB

Implementation process of the ongoing water reforms in Pakistan is confirming the complexity of the Pakistani irrigation system. From the total irrigated 16 Mln ha of land, Rechna Doab represents about 1/7 with its 2.3 Mln ha. The area is home to about 14 Mln people, of which about half is living in rural areas. The majority of farmers (about 85%) have relatively (for Pakistan) small land holdings, approximately 5 ha. The authority and responsibility for the irrigation water management is fragmented and it is distributed amongst different departments and agencies, which is a paradigm that is not easily dealt with. The water supply for irrigation at the federal level rests with the Indus River System Authority (IRSA) and its regulatory arm - Water and Power Authority (WAPDA), which has two wings - power and water. WAPDA is responsible for the construction of large infrastructure and operation of dams, head works, and large primary and link canals. In Rechna Doab area the WAPDA was also made responsible for tile drainage projects and planning and installation of tube wells, drilled under various salinity control and reclamation projects (SCARPs), starting during the sixties. The basic aim of these projects was to reduce waterlogging and salinity problems, by engaging vertical drainage and augmenting water supplies with good quality of groundwater through deep tube wells. Some of the SCARPs were successful, but some have caused damage to the groundwater.

Considering the need of irrigated agriculture within the Indus River Basin, an increase of productivity of land and water are the key issues to be addressed by combination of technological advances and institutional arrangements. The Rechna Doab area was marked as a suitable study area to identify combinations of technological and institutional strategies to manage conjunctively surface and groundwater at a regional scale and promote an environmental sustainability, while maximizing the yield per unit of water.

REFORMS TO STREAMLINE ORGANIZATION OF WATER MANAGEMENT

In Pakistan the land is abundant and water resources are scarce. The irrigated agriculture is the backbone of the country's economy. The government has embarked on various reforms in irrigated agriculture during the eighties, more followed in 1997 and during the last few years. First, reforms were proposed at the regional - provincial level to affect the system at top and bottom. At the higher level of the system the changes addressed primarily some legal and regulatory aspects towards streamlining of the irrigation and drainage system and changes in administrative aspects - replacement of the set up and procedures with more transparent arrangements. At the lower level the changes were of operational nature, to achieve more economical and effective operation and maintenance of the irrigation, drainage and flood control in the province. These changes also introduced participation of beneficiaries in the operation and management of the systems.

It has been recognized that within the Indus River Basin, apart from the surface irrigation system, a sizeable reservoir of groundwater is formed that can be used to supplement the canal water. Good groundwater water quality can be found in the upper reaches, and slightly more saline in the center and lower parts of the Doab. Shallow aquifer has generally good water quality because of being recharged by the canal water; water at depths, more than 30 m, is more saline. Many public and private tube wells have been dug under several Salinity Control and Reclamation Projects (SCARPs), which were started during 1960s. The numbers of private wells were estimated as over 193,000 in 1997 (Rehman et al). The annual pumping volume was estimated as 1.173 Mln ha-m from the private wells and 0.303 Mln ha-m from public wells, respectively. The use of private tube wells proved to have good results in lowering the water table and reclaiming the land, as well as increasing cropping intensity. Seven SCARP projects were initiated, some of them achieving good results in alleviating or reducing waterlogging and helping to replenish canal water supplies. Others became a failure and caused undesirable effect on groundwater quality and groundwater over-use, resulting in serious environmental problems.

In conditions of impaired quality of groundwater the tube wells can only worsen the environmental situation. When the groundwater quality is good, the tube wells can indeed help to reduce water logging and increase irrigation water supply. However, in maintaining good groundwater quality, monitoring and regulation play an important role. Due to the lack of control of drilling, licensing, and other aspects of groundwater management, the number of private tube wells has increased and the groundwater have been mined and over exploited, resulting in up-coning of saline water in many areas.

A number of legal instruments were adopted in all four provinces (Punjab, Sindh, Baluchistan, and Northwest Frontier Province), but the implementation has progressed most in Punjab, where also a number of land and water reclamation projects were organized. Initially, the legal reform consisted of passing of a bill for creating a Provincial Irrigation and Drainage Authority (PIDA), transformed from Provincial Irrigation Departments in each province; they became autonomous bodies responsible for policy formulation and supervision of the entire management of irrigation and drainage network. Therefore PIDAs became responsible for the operation and maintenance of the system from the head works via the main and distributaries canals to the outlets of watercourses. Under the reforms and hierarchy for operation and maintenance (O&M), some responsibilities

would be passed on to farmers that were to be organized into Water Users Associations (WUAs)⁵ at the water course level and Farmers organizations (FOs) - to take over the operation and maintenance of the minor canals and distributaries at the level of minors and distributaries.

The Punjab On Farm Water Management (OFWM) Department became active in establishing informally WUAs in the late seventies, and later - providing subsidies and training in the on-farm water management. However, this development of WUAs has not taken root very well over the entire province, perhaps because the farms are small (less than 5 ha) and the area serviced by a watercourse is also small (average about 250 ha)⁶. The OFWM program is now focused more on creating FOs. The establishment of FOs has progressed relatively well so far, taking into account that it is a lengthy process requiring many meetings and consultations with farmers. The size covered by an FO can range from 5,000 to 20,000 ha.

Additionally, under the reform activities, specific arrangements were made to create Area Water Boards (AWB), receiving water from PIDA as an intermediate level entity. In Punjab, a pilot AWB has been established covering about 400 000 ha, and supplying about 100 distributaries where FOs are in the process of creation. The AWB should operate through management board, on which also farmers should participate. This process of developing AWBs, however, seems to be stagnating, and therefore can be rated only as being in its infancy, needing reinforcement and stronger government commitment and support.

During the late nineties the Punjab PIDA enacted different Acts to address rules and regulations concerning PIDA farmers' organizations - in terms of organization, elections, registration, financial regulation, conduct of business, management, and transfer of irrigation schemes. Apart from these legislative instruments, a few administrative instruments were prepared; these relate to notification of AWB and Agreements between PIDA and Revenue Department for Collection of the revenues as well as PIDA and Punjab Irrigation Department (PID) for O&M of the infrastructure. Additional administrative instruments include guidelines and standards for the FOs and procedure for collecting water charges. For the purpose of Irrigation Management Transfer (IMT), the FOs must sign an agreement with the PIDA.

The arrangements for water management and O&M in the provinces and therefore also in Rechna Doab, are still somewhat fragmented and do not respond to the needs required for utilization of surface and groundwater and other sources with more marginal water quality to fully institutionalize the CWM. Typically, the technical solutions call for evolution of the institutions and dictate the needs for the adjustments and changes in scope of the managing entities, as well as the devising of new legal and supporting regulatory framework.

The only law dealing with groundwater stems from 1952 and was intended merely for land reclamation purpose - improvement of waterlogged areas, controlling operation of state tube wells and monitor boring of private tube wells. The Punjab Soil Water Reclamation Board was formed, but dissolved twenty years later to merge with the Provincial Irrigation Department. Some functions, especially for controlling the groundwater have become convoluted when the board was absorbed

⁵ WUA ordinance in Punjab was issued in 1981, however, providing only opportunity to farmers to join into a WUA, with no powers to the organization itself.

⁶ The literature and experience tells us that only WUAs large enough, approximately 2000 ha and larger can be sustained financially as farmers' water managing organizations.

into the department and others became cumbersome to execute; some rules for water supply seemed redundant, complicated by the former, somewhat ambiguous power of the board.

TARGETING GROUNDWATER UNDER IRRIGATION SECTOR REFORMS

The basic and urgent need for improvement of the legal and regulatory framework in Punjab is groundwater management and view of the water use and management in a conjunctive manner. With the introduction of a participatory process into the reform process the chance for improving the land and productivity and preventing soil degradation is much increased. The participation of relevant stakeholders is a supporting element for the sustaining of the environment, resulting in better O&M and improvement of rural livelihoods and socio-economic situation. This can further be strengthened by establishing farmers support services, such as agricultural and water management extension.

In general, water institutional reforms in agriculture are connected to changes in governance of rural development. The broader framework of integrated policies for planning and management of water resources aims to assure that environmental features do not deteriorate and integrated surface and groundwater use and management is adopted. This relates to permitting of groundwater withdrawals, licensing of wells and well drillers, and enforcing the rules. Further, monitoring and data base development, research development and research management would be an integral part of the local and/or basin governance.

Within the context of groundwater development policies the protection of certain aquifers or prohibition of abstraction, associated with organizational powers and legal framework, should be addressed. Water rights and regulations for groundwater development and its use must be clear and equitable. Moreover, implementing entities and organizational linkages must be assigned so that decentralization of administration and decision-making processes can offer substitutes for centralized structures. An impact of this kind has been felt in Sindh and in Hakra 4 in Punjab at the lower level of the system, but referring mainly to surface water management.

SHORT TERM PROSPECTS FOR BETTER CONTROL OF GROUNDWATER

In regard to better control of groundwater use a five-year project called Punjab Private Sector Groundwater Development Project (PPSGDP) was initiated in 1997. The project, covering both fresh and saline groundwater areas, intended to redefine the Government's role in groundwater development, and provide assistance to facilitate changes, as well as develop regulatory framework to ensure sustainable use of groundwater resources.

Additional progress in groundwater management can be expected from the Framework for Action according to the vision of 2025, derived by the Pakistan Water Partnership. In the least, the action for groundwater calls for the enforcement of legislation at the provincial level, defining rights to groundwater and limiting its extraction, as well as introducing administrative arrangements for effective enforcement of groundwater laws - in three years from 2002.

The Framework for Action includes another significant aspect of water management - criteria for allocation of the available water resources for different uses. It can be envisaged that under the relevant studies for the most productive use more studies would be undertaken to evaluate a problem with disposal of drainage and use of the marginal water quality, making it pertinent for adjusting

and devising the appropriate infrastructure as well as institutional arrangements. Such step would further aid in the efforts to adopt Conjunctive Water Management.

IMPROVEMENT OF GOVERNANCE FOR WATER MANAGEMENT IN AGRICULTURE

To achieve effective O&M of irrigation and drainage systems in all provinces and step up the water management towards more integrated and conjunctive water resources management, the objectives of an institutional development program have to be clearly defined and country's commitment shall be secured.

Particularly important in the context of improving governance of water and institutions is the time dimension. It involves the staff at all levels of the implementing body as well as staff of the other relevant agencies and entities. Therefore, full commitment to the institutional development is necessary, behind which, of course is a host of political and social factors, as well as complex interplay of different political and social elements, that are endemic to each situation.

In countries with successful management of water resources the guiding element is a National Water Resources Policy, that addresses management of fresh and brackish water, applies to surface and groundwater and takes a comprehensive approach of CWM, recognizing the needs of different water uses as well as different sectors' needs.

The following principles can guide successfully water resource management: (i) ownership (covering surface and groundwater; (ii) sustainable management (covering economic, social, financial, and environmental considerations; (iii) openness and participation; (iv) assurance and flexibility of water allocation (water rights); (v) equitable cost sharing; (vi) sectoral emphasis; (vii) management of information and sharing amongst agencies; and (viii) gender (low income, female headed households).

PROCESS OF CHANGE

The change of water institutional arrangements is a process that needs to be advocated, championed and managed, as well as planned, designed, and implemented. Therefore, leadership and roles of individuals and organizations in such a process need to be assigned and the process monitored. Given that the government is supportive and committed to make the changes happen, an advocate and champion of the reform have to come from a higher government level. Then the agents of the reform process execute activities and implement different tasks at the lower level of the system. Managing and monitoring of the process is essential. Also, collaborating of all organizations (including scientific and research institutes) having a special interest in water resources management is imperative for any reform to succeed, because it will create and reinforce broad-based partnerships in rural institutional development.

Trade-Offs Between Gross Farm Income, Groundwater and Salinity at Irrigation Sub-Divisional Level

Waqar A. Jehangir¹, Muhammad Ashfaq² and Kashif Majeed Salik³

ABSTRACT

This paper represents a part of study where the SWAGMAN Farm Model has been used to evaluate the financial and environmental trade-offs for effective conjunctive water management in the Rechna Doab. The data used in this study were collected from 544 sample farms located in twenty-eight irrigation sub-divisions of Rechna Doab. The SWAGMAN Farm Model was developed by CSIRO (Australia) and was adapted for 28 sub-divisions in the Rechna Doab. Among 28 sub-divisions this paper reports the results from three sub-division namely, Shahdra, Aminpur and Wer. The optimization results showed that it is possible to increase the total gross margins while keeping the salinity levels and the changes in depth to water table in the acceptable limits through conjunctive water management at the sub-division level. The model estimated an increment in the total gross margins to the tune of Rs. 25.41, 2.26 and 31.31 millions for Aminpur, Shahdra and Wer sub-divisions, respectively.

INTRODUCTION

The international literature is filled with the studies on conjunctive water management and its impact on crop productivity and related issues [O'Mara (1988); Bredehoeft and Young (1988); Shah (1988); Gangwar and Toorn (1987), Datta and Dayal (2000), Lingen (1988), Gorelick (1988), Brewer and Sharma (2000) and Raju and Brewer (2000)]. In Pakistan, the literature review shows that all of the previous studies conducted in the area of water management reported the management problems leading to the inefficiencies in irrigation application and reduction in crop productivity, [Kijne and Velde (1991); Mustafa (1991) and Siddiq (1994)]. None of these studies have taken into consideration the trade offs between gross farm income, groundwater and salinity at irrigation subdivision level. To answer the issues of spatial differences in the trade offs between gross farm income, groundwater and salinity at irrigation subdivision level this paper reports the results of the optimization modeling at the sub-divisional level in the Rechna Doab. The Rechna Doab is comprised of 2.98 million hectare (Mha) and is located between the rivers Ravi and the river Chenab (Figure 1). In arid and semi-arid climate of Rechna Doab, water availability plays an important role in determining the gross farm output/income along with other resources. Like other areas of Pakistan, the Rechna Doab is also facing the shortage of canal water supplies. About 57 percent of the farmers keep part of their lands fallow due to shortage of canal water. To meet the

¹ Senior Agricultural Economist, IWMI Regional Office, Lahore, Pakistan

² Agricultural Economist, IWMI Regional Office, Lahore, Pakistan

³ Junior Researcher, IWMI Regional Office, Lahore, Pakistan

crop water requirement, farmers use groundwater along-with canal water. Therefore, where soils are suitable for specific crops, the presence of good quality groundwater helps in enhancing the productivity of crops. In Rechna Doab, out of the total surveyed area of 1.95 Mha, about 1.63 Mha of the area has fresh and useable groundwater supplies but 0.321 Mha has saline groundwater (Rehman et al. 1997). Thus the farmers with the area of saline groundwater have little opportunity to utilize groundwater alone in the critical periods of crop growth. The huge increase in population, low rainfall, and decreasing capacity of fresh water reservoirs, demands for devising the methods to fulfill the increasing demand of fresh water for the crops. Moreover, the presence of bad quality groundwater in the lower reaches of the Rechna Doab also calls for finding out the optimal solutions in conjunctive water management, which may help the farmers to raise the crops in a profitable way and at the same time also keep the hazards of salinity/sodicity to the lowest levels.

Figure 1: Locations of Aminpur, Shahdara and Wer Sub-divisions in Rechna Doab, Punjab Pakistan

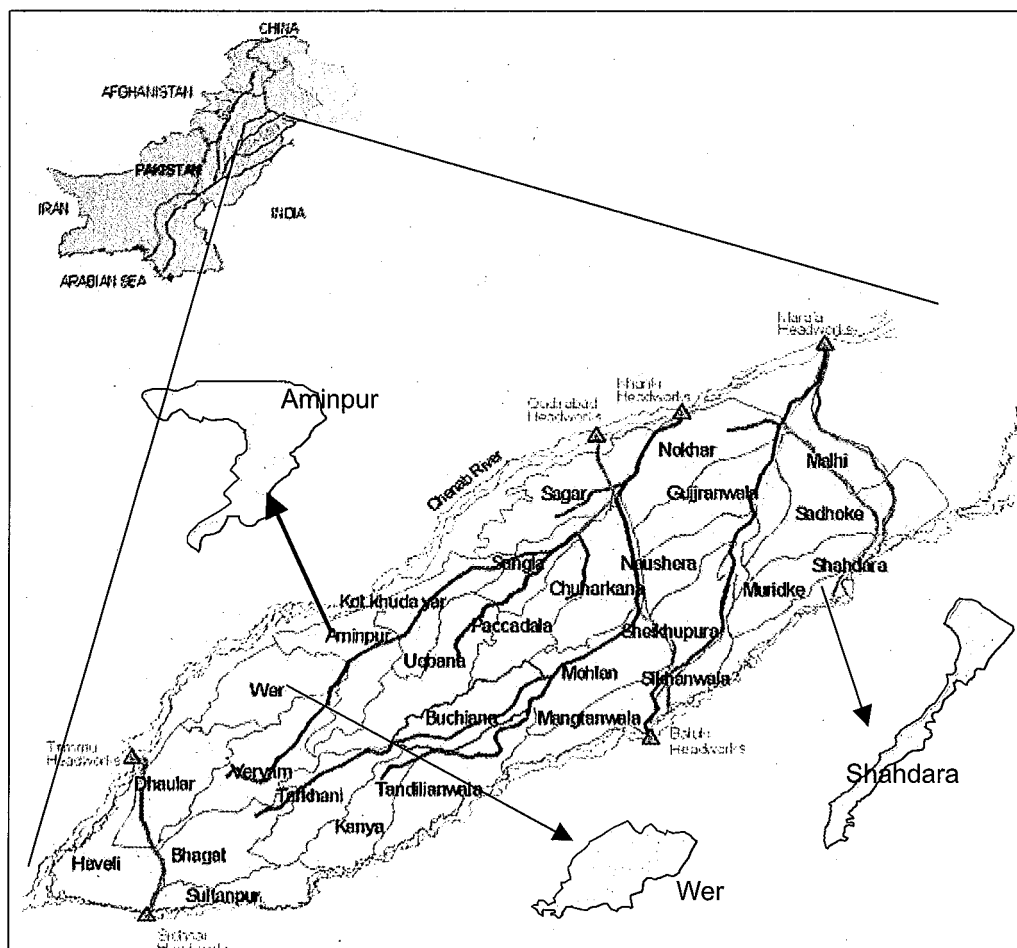

The SWAGMAN Farm Model provides an opportunity to evaluate the financial and environmental trade-offs between gross farm income, groundwater level and salinity at the sub-division level. This paper describes the result of the Model for Shahdara, Aminpur and Wer irrigation sub-divisions. The

objectives of this paper were to determine the possibilities of increasing total gross margins by taking optimal mix of crops; to determine the ways of best use of conjunctive water for irrigation and to estimate the impact on gross margins with respect to optimal crop mix, depth to water table and soil salinity. The paper is divided into five major sections. The section II explains the methodology, which is followed by results and discussion in section III. The conclusions are given in section IV and the model limitations and way forward are discussed in the final section of the paper.

METHODOLOGY

Study Area

The Shahdra, Aminpur and Wer sub-divisions are located in the upper, middle and the tail parts of the Rechna Doab (Figure 1). These sub-divisions had about 42.28, 77.27 and 63.67 thousand hectares of cultivated area, respectively. The water table depths were reported to be 3.42, 6.09 and 6.78 m in Shahdra, Aminpur and Wer sub-divisions respectively. Water allocation for the Shahdra, Aminpur and Wer sub-divisions was 0.73, 6.26 and 5.1 million mega liters (ML), respectively. The 25 years average of annual rainfall was reported to be 631, 325 and 314 mm in Shahdra, Aminpur and Wer sub-division, respectively.

Data Collection

The primary data sets were collected through a well-designed pre-tested questionnaire, which were used to collect the information from 544 sample farms located on 188 sample sites in the Rechna Doab. Physical and meteorological data were collected from secondary sources comprised of Punjab Irrigation and Power Department (PID), Salinity Monitoring Organization (SMO) and Meteorological Department. Physical data includes soil texture, area under different soils, textural classes and water quality. The meteorological data included information about rainfall, humidity, sunshine, wind speed and temperature. The data about irrigation, infrastructure and the designed discharges were collected from irrigation department.

Model Specification

The SWAGMAN Farm Model is an annual model that allocates land to different crops on annual basis, based on distribution of soils on farms within sub-divisions. Potential land uses, crop evaporative requirements, current irrigation practices, leaching requirements, annual rainfall, leakage to deep aquifer, depth to water table, capillary inflow from shallow water table, salt concentration of irrigation and groundwater and taking into consideration the economic returns from potential land uses, it maximize total gross margins for the sub-divisions subject to the given economic and environmental constraints. In the Rechna Doab, the crops sown during the Rabi and the Kharif seasons were taken in to account. The major crops during the Kharif season were Rice, Cotton and Kharif Fodder while in during the Rabi season the major crops were Wheat and Rabi Fodder. The sugarcane was an annual crop so it was treated as such in the Model. The specification of the model is given as follows

$$TGM = \sum_c \sum_s X_{c,s} (GMLW_c - IRRN_{c,s} \times WPRICE)$$

Where:

TGM	= Total gross margin (Rs.)
X	= Area under land use C and soil type S (ha.)
GMLW	= Gross margin of a land use less cost of irrigation water (Rs./ha.)
IRRN	= Irrigation water used for land C and across soil types S (ML/ha.)
WPRICE	= Price of water (Rs./ML)
C	= Land uses under various cropping patterns in the sub-division
S	= Soil types across the farms in the sub-division

The model was subjected to the constraints namely, area, salt balance, net water balance, pumping of groundwater and water allocation. As far as the area constraint was concerned the model specified that the rice crop could not be grown on sandy loam and loam soils and cotton was not allowed to grow on clay-loam and silt-clay soils. The second constraint considered in model was salt balance. The salt accumulation due to irrigation, rainfall and capillary up-flow within the root zone required to be removed by leaching and drainage practices, so that the amount of salt in the root zone should be less than the specified level of salinity. The third constraint considered in the model was net recharge. Net recharge or water balance level was defined as the allowable rise in the groundwater-table. Net recharge included both, recharge and discharge mechanisms. The fourth constraint in model was pumping of groundwater. If pumping was allowed in the model then the new depth to water table was determined by taking the difference between initial depth to water table and the change in the depth to water table after optimization. If there has been no pumping option then the model calculate the water required to maintain the water table at the present level. The last constraint taken in the model was water allocation. The total water requirements were not allowed to exceed the annual water allocation to the respective sub-divisions. The water allocation for a specific subdivision was calculated by multiplying area under specific crops on different soil types and irrigation requirements on farms. The objective function was solved by using the integer programming solver GAMS, subject to given constraints.

RESULTS AND DISCUSSIONS

Figures 2-13 provide the model results computed through SWAGMAN Farm Model for the optimal land use, total gross margins, impact on salinity and depth to water table with respect to Shahdra, Aminpur and Wer subdivisions in the Rechna Doab. With respect to the location of these subdivisions the Shahdara subdivision was located in the Upper Rechna Doab and was comprised of a total culturable command area of 42279 hectares. Figure 2 shows that the optimized gross margins of Rs. 574.736 million could accrue through the changed cropping pattern as compared to the actual gross margins of Rs. 552.111 million calculated for existing cropping pattern in the Shahdra subdivision. It shows that there is a possibility to increase the gross margins by Rs. 22.625 million by adopting the cropping pattern proposed by the model. The model proposed to reduce the area under rice-wheat rotation from 32.22 thousand hectare (Tha) to 8.40 Tha and to increase the area under maize-wheat rotation from 0.03 Tha. to 28.38 Tha. Similarly, the model proposed not to grow any crop-under Rabi fodder-rice rotation and under sugarcane, which currently was practiced on 4.41 and 2.07 Tha, respectively in the Shahdra sub-division. The major reason for this proposed change in the cropping pattern was due to the fact that the objective function of the model tried to maximize the total gross margin by taking into consideration the crop mix and soil mix which are suitable for specific cropping patterns. The decrease in area under rice-wheat cropping pattern was mainly due to soil limitation described in the model. As specified in the model, the rice crop cannot be grown in loam and sandy loam soils that constitute the major part (about 29 Tha) of the Shahdra subdivision,

thus, led the model to propose the reduction in area under rice-wheat rotation. On the other hand, these soils were suitable for the cultivation of maize crop thus model has proposed a rise in area under maize-wheat cropping pattern to 28.38 Tha. This re-adjustment of area under proposed cropping pattern as compared to the current situation led to generate additional gross margins of Rs. 22.625 million in the Shahdra sub-division as already mentioned above. The proposed cropping pattern not only enhanced the gross margins but also had some positive impacts on environment in the Shahdra sub-division. The model results showed that the groundwater would go down by 10 cm from 3.42 meters to 3.52 meters (Figure 4) and the salinity would be reduced to about 0.66 dS/m (projected salinity level 0.90 dS/m salt as compared to the current salinity level of 1.56 dS/m) (Figure 5).

Figure 2. Total Gross Margin in Shahdara Subdivision

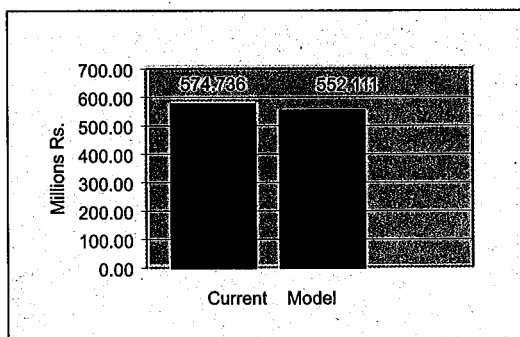

Figure 3. Land Use in Shahdara subdivision

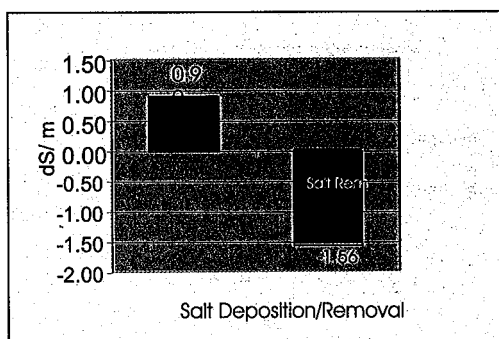

Figure 4: Depth to Watertable in Shahdara subdivision

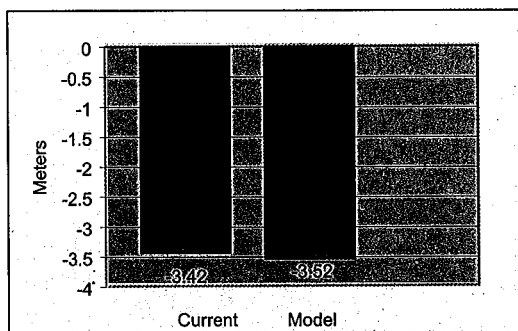
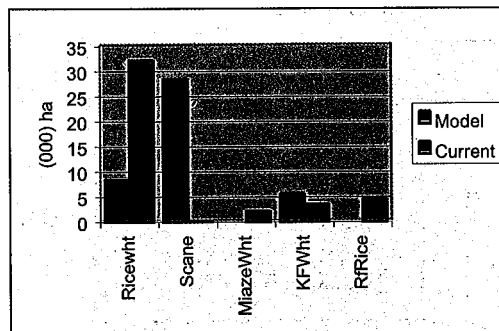

Figure 5: Impact on Salinity in Shahdara subdivision



The execution of the model for Aminpur sub-division led to the results indicating 11 percent increase in the gross margins from the proposed optimized cropping patterns in Aminpur sub-division as compared to the existing cropping patterns. The optimized cropping patterns raised the gross margins from Rs. 2050 million to Rs. 2304 million (Figure 6). The model proposed an increase in area under sugarcane and maize-wheat rotation from 22.97 to 46.38 and from 9.57 to 10.5 Tha, respectively. The model also proposed to reduce the area under cotton-wheat, kharif-fodder-wheat and rabi fodder-cotton rotation from 14.35 to 1.8, from 16.75 to 13.62 and from 13.64 to 4.98 Tha, respectively (Figure 7). This major shift was due to high gross margins in the sub-division from sugarcane crop as compared to the cotton but it increases the crop water requirement. The soils in Aminpur subdivision mainly comprised of moderately coarse soils (Rehman, G. *et al.*

1997). These soils are having mainly loam and sandy loam texture. Main crops in this subdivision are sugarcane, cotton, wheat and fodder. As the coarse texture of Aminpur soils do not allow the cultivation of rice therefore it remains invisible both in existing and proposed situation. The model results indicated that the groundwater table might rise by 9 cm and come up to surface from 6.09 meter to 6 meter (Figure 8). The model showed that salinity level in the Aminpur subdivision would rise from 1.28 to 1.41 dS/m (Figure 9) and this increase in soil salinity might be due to use of saline groundwater. The conjunctive use of saline groundwater with the canal water for production of high value crop might increase gross margins in the short run but increasing use of groundwater in the long run might result in the waterlogged conditions if high delta crops like sugarcane would be continuously grown in the Aminpur sub-division.

Figure6: Total Gross Margin in Aminpur subdivision. Figure 7 : Land Use in Aminpur subdivision

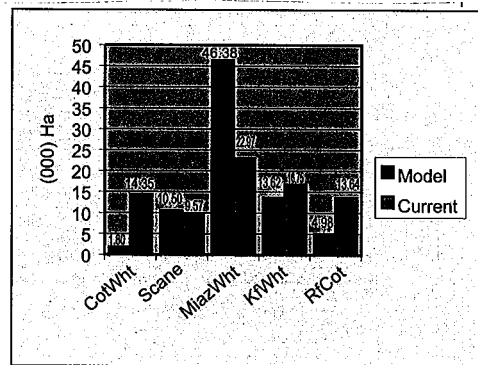
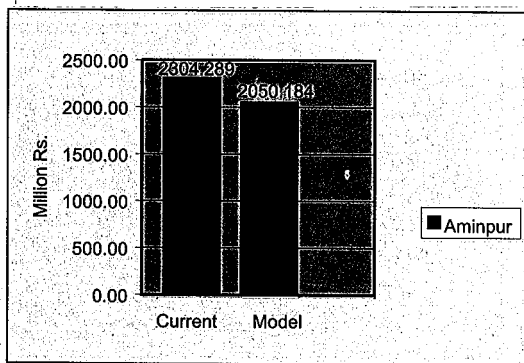

Figure 8 : Depth to Water Table in Aminpur Subdivision

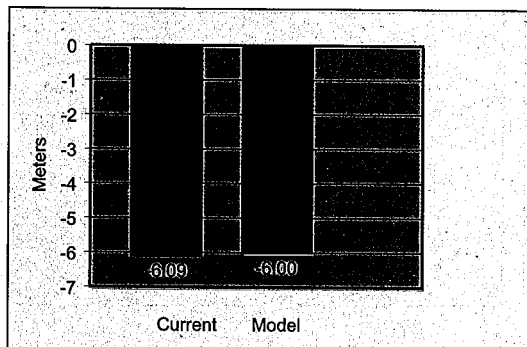
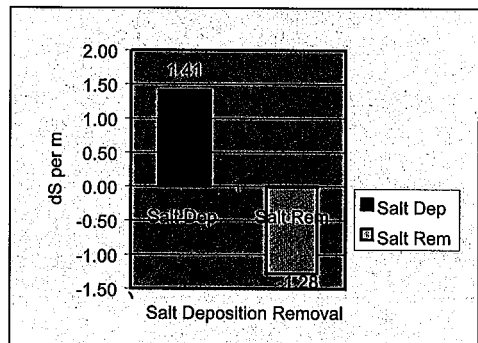

Figure9: Impact on Salinity in Aminpur Subdivision



In the Wer subdivision, where the soils have a balanced mix between moderately coarse sandy loam and fine sandy loam to medium textured loam, silt loam soils, the optimization of SWAGMAN Farm Model resulted in the changes for the cultivated areas under different crops being raised in the Wer sub-division. This redistribution of area under different cropping patterns provided 23.59 percent increase in gross margins; raising it from the current level of Rs.1013.92 millions to optimized level of Rs.1326.99 millions (Figure 10). The model allocated 30.5, 16.63 and 16.55 Tha of the cultivated areas to sugarcane, Kharif fodder-wheat, and Rabi fodder-cotton rotation respectively (Figure 11). The presence of the moderately coarse to medium textured soils in the Wer sub-division constrained the model to allow the cultivation of rice and thus the model proposed not

to grow crops under Rabi-fodder-rice rotation; currently this rotation is being followed on 15.41 Tha. of land in the Wer sub-division. The model also reduced the area under Kharif fodder from 32.35 to 16.62 Tha in the Wer sub-division without considering its impacts on the livestock population in the area. Basically, this flaw was due to the fact that the model only considered the gross margins from the crops sector and then related them to the soils, water requirements and the other environmental conditions. It did not take into consideration the livestock sector as such because it was not included in the model. The excessive extraction of the groundwater for sugarcane might result in lowering of water table by 10 cm in the Wer subdivision as the new depth to water table was estimated to be 6.88 m as compared to the original water table depth of 6.78 meters in this sub-division (Figure 12). The model results showed that the proposed cropping pattern would not only increase the gross margins but it would also help to reduce the salinity levels to about 0.17 dS/m (Figure 13).

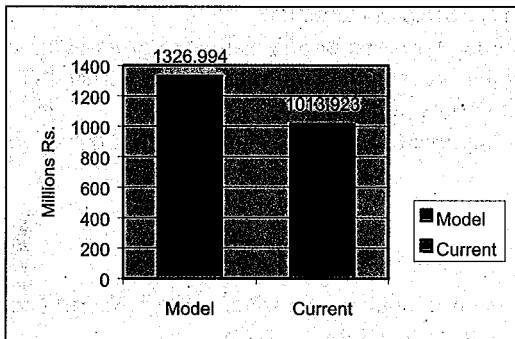

Figure 10: Total Gross Margin in Wer Subdivision.

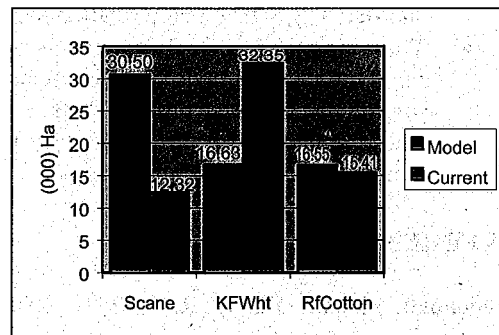

Figure 11: Land Use In Wer Subdivision.

Figure 12 Depth to Water Table in Wer Subdivision.

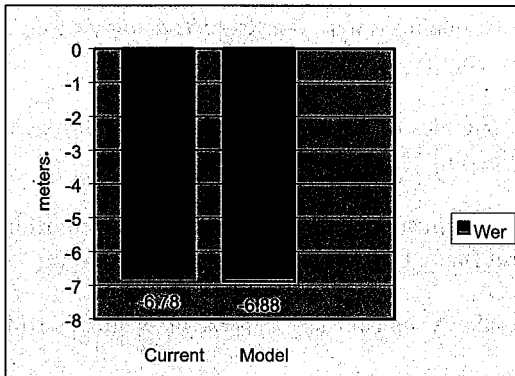
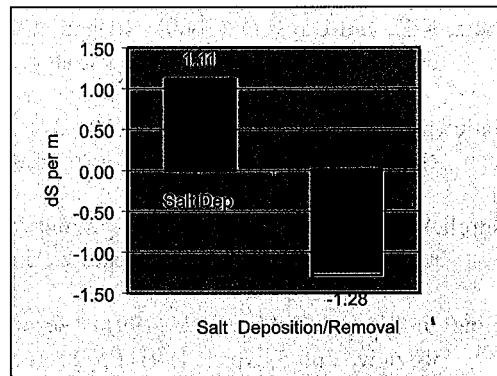

Figure 13: Impact on Salinity in Wer



CONCLUSIONS

The paper revealed that it is possible to increase the gross margins to the tune of Rs. 25.41, 2.26 and 31.31 million in the case of Shahdra, Aminpur and Wer sub-divisions, respectively by changing the crop mix across farms in these sub-divisions. The model provided the estimates about the new

depths to water table which show that in the case of Shahdra and Wer sub-divisions the use of tubewell would lead to increase the depth to water table by 10 cm while in the case of Aminpur sub-division the depth to water table would rise by 9 cm. With respect to the salinity conditions in these sub-divisions the salinity level would decrease in the Shahdra and Wer sub-divisions by 0.66 and 0.17 dS/m, respectively while the results showed an increase in the salinity level by 0.2 dS/m in the case of Aminpur sub-division. These results are constrained by the model limitations that are listed below.

LIMITATIONS OF THE MODEL AND WAY FORWARD

The limitations of the SWAGMAN Farm Model are enlisted below:

- The model takes into consideration the gross margins coming from different crop mix on the farms with in the sub-divisions.
- The model is annual and did not take into account the single crop grown on the farms in the sub-division, rather a crop rotation has been specified in the model.
- There was no live stock component and the model based on the estimated gross value of the fodder have proposed not to include fodder crops in the crop rotation but farmers have to grow the fodder in order to sustain their livestock population.
- These limitations in the model need to be improved to get better optimization out of the simulation results from the model.

REFERENCES

- Bredenhoft, J.D. and Young, R.A.(1988), 'Risk aversion in conjunctive water use', A World bank Symposium on Efficiency in Irrigation, series 2, The World Bank, U.S.A
- Brewer, J.D and Sharma, K.R. (2000), 'Conjunctive management in the Hardinath Irrigation System,, Nepal, International Water Management Institute, Nepal. Report No. R-94.
- Datta, K.K. and Dayal,B. (2000), 'Irrigation with poor quality water : An empirical study of input use, economic loss, and coping strategies', Ind. Journal of Agri. Econ. Vol.55, No.1.
- Gangwar, A.C. and Toorn, W.H.V.(1987), 'The economics of adverse groundwater conditions in Haryana state, Ind. Journal of Agri. Economics. Vol.42, No.2
- Gorelick, S.M. (1988), 'A review of groundwater management models', A World Bank Symposium on Efficiency in Irrigation, Series 2, The World Bank, U.S.A.
- Kijne, J. W. and Velde, E. J. (1991) 'Secondary salinity in Pakistan Harvest of Neglect'. IIMI Review, Vol. 5, No. 1. 1991. Pp. 15-16.
- Lingen, C. (1988), 'Efficient conjunctive use of surface and groundwater in the People's Victory Canal, A World Bank Symposium on Efficiency in Irrigation, series 2,The World Bank, U.S.A.

- Mustafa, U. (1991), 'Economic impact of land degradation (Waterlogging and salt effected soils) on rice production in Pakistan's Punjab'. Unpublished Ph.D. dissertation, University of Phillipines at Las Banos, (1991).
- O'Mara, G.T. (1988), 'The efficient use of surface water and groundwater in irrigation: An overview of the issues', A World bank Symposium on Efficiency in Irrigation, series 2, The World Bank, U.S.A.
- Raju, K.V. and Brewer, J.D. (2000), 'Conjunctive management in the North Bihar,, India, International Water Management Institute , India. Report, No. R-95.
- Shah, T. (1988), 'Managing conjunctive water use in canal commands: Lessons from the analysis of the Mahi right bank canal,Gujrat' , Research paper 3, Institute of Rural Management, Anand, India.
- Siddiq, A. (1994) 'Sustainability of Indus Basin: impact of tertiary salinity on wheat productivity, damage assessment and future public policy'. Ph.D. Dissertation, University of Illinois, Urbana-Champaign, U.S.A.

Use Of Poor Quality Groundwater Through Conjunctive Water Management

Mushtaq Ahmad Gil¹, Bashir Ahmad Solehria², Nisar H. Bukhari and Maqsood Ahmad³

ABSTRACT

Water is a limiting factor for agricultural production in arid and semi-arid climatic conditions. The main source of irrigation in Pakistan is derived from vast canal system. The amount of available surface water is, however, inadequate to meet crop water requirements. The deficiency is supplemented with groundwater, which is often of poor quality and unfit for irrigation purposes. Its continuous use leads to soil degradation. There is a shortage of 1.5-acre feet of water per cropped acre in the culturable command areas, which affects the crop yield and creates serious problem of salinization of productive lands.

Pakistan has 55 million-acre feet of groundwater reserves. Half of this water can be used for crop production by adopting appropriate technologies while the remaining half is hazardous and cannot be used for crop production without treatment. Poor quality groundwater can, however, be utilized for crop production in conjunction with canal water in light textured soils. Although conjunctive use of fresh and saline water results in improvement of infiltration rate and reduction of salinity and sodicity of upper soil layers but its continuous use causes accumulation of sodium ions in lower layers leading to reduced permeability.

Poor quality groundwater can be better utilized through its cyclic use i.e. alternate irrigation of canal and tubewell water, which causes less built up of salts in soil profile than conjunctive water application. Both rice and wheat give better yields by cyclic use of saline water with canal water than conjunctive use as irrigation with fresh water flushes the salts added by preceding irrigation of poor quality water. In areas of acute water shortage, wheat can be grown with tubewell water whereas canal water can be used for growing rice during the abundant water supply period. The water so applied for rice crops also flushes down the salts. Saline-sodic and sodic groundwater can also be successfully utilized for crop production through its treatment with Sulfurous Acid and Gypsum. This technology is also helpful in reclaiming sodic/saline-sodic soils for better crop yields. Adopting furrow and bed planting technology in poor water quality areas may further ensure crop growth. Similarly, by adopting other Resource Conservation Technologies such as reducing canal irrigation losses at primary secondary and tertiary level, precision land leveling and Zero tillage Technologies may enhance crop productivity using poor quality groundwater along with canal water.

¹ Director General Agriculture (Water Management) Punjab, Lahore

² Assistant Director (CD) Water Management, Shahdara Lahore

³ Deputy Director (Hqs) and Assistant Director (Tech) DGA(WM) Lahore

INTRODUCTION

The need for more efficient water management is gaining recognition due to the increased cost of water supply, the growth in the demand of water, and greater environmental and social impacts of water programs. "Conjunctive use" of surface and groundwater resources provides opportunities for increasing net benefits to the water users. The concept of conjunctive use of groundwater and surface water resources was originated in the late 1940s in the arid Western United States in response to the water problems of that period. Today, the conjunctive use concept is widely accepted by water resource planners and is considered prerequisite to optimal water utilization.

Conjunctive use may be implemented in a number of ways as well. One of the examples is of a situation where good quality surface water is available in limited quantity, whereas poor quality groundwater is relatively plentiful. The concept of "conjunctive use" would blend waters from the two sources of differing qualities to obtain more water of poor, but acceptable quality [1]. The blending should vary with the relationship between yield and water quality for a particular crop and soil.

Adequate food production is a pressing need in many less developed countries. In Pakistan, the production of food can potentially be increased several times over the present supply. The land resources of the Indus Basin agricultural system far exceed its related water resources. It is, therefore, of paramount importance that the scarce water resources be optimally developed and managed. Chaudhry et al. (1974) discussed an optimal conjunctive use model for the Indus Basin, Pakistan [2].

Due to drought conditions prevailing since 1997 to date, the surface and groundwater reservoirs were depleted which resulted into destruction of vegetation and orchards. The animals and human beings suffered from severe food and water shortages. It is, therefore, the need of the hour to adopt Water Management Techniques like conjunctive water management using poor quality groundwater being treating with Sulfurous Acid and adopting Furrow and Bed planting for augmenting inadequate surface water and saving available water through other resource conservation techniques such as reducing canal irrigation losses (at primary, secondary and tertiary level), precision land leveling and Zero tillage technology.

USE OF POOR QUALITY WATER THROUGH CONJUNCTIVE WATER MANAGEMENT AND TREATING WITH SULFUROUS ACID (H₂SO₃)

Water is a limiting factor for agricultural production in arid and semi-arid climatic conditions. The main source of irrigation in Pakistan is from vast canal system. The total water diversions from the rivers and streams are estimated to be 142 million acre feet/year and the amount diverted to canals is 103 million acre feet per year; 39 million acre feet of water enters into the Arabian Sea without any proper management. The conveyance and other losses from canal head to the field comprise about 50% resulting in net diversions of only 51.5 million-acre feet. Given that the cultural command area is 34.6 million acres, indicates that the water supply to the field is only 1.5-acre feet. The optimum requirement for crops is 3-acre feet per acre. This means that there is a shortage of 1.5-acre feet per cropped acre in the culturable commanded area [3]. This shortage of water is affecting the crop yield and creating serious problem of salinization of productive lands. The amount of available surface water is, however, inadequate to meet crop water requirements. The deficiency is supplemented with groundwater, which is often of poor quality (unfit for irrigation purposes). Its continuous use

leads to soil degradation. Pakistan has 55 million-acre feet of groundwater reserves [4]. Half of this water can be used for crop production by adopting appropriate technologies while the remaining half is hazardous for irrigation. Poor quality groundwater can, however, be utilized for crop production in conjunction with canal water in light textured soils. Although conjunctive use of fresh and saline water results in improvement of infiltration rate and reduction of salinity and sodicity of upper soil layers but its continuous use causes accumulation of sodium in lower layers leading to reduced permeability. Area irrigated by different sources in Pakistan is given in table 1.

Pakistan has 55 million-acre feet of groundwater reserves. Half of this water can be used for crop production by adopting appropriate technologies while the remaining half is hazardous and cannot be used for crop production with out treatment. Poor quality groundwater can, however, be utilized for crop production in conjunction with canal water in light textured soils. Although conjunctive use of fresh and saline water results in improvement of infiltration rate and reduction of salinity and sodicity of upper soil layers but its continuous use causes accumulation of sodium ions in lower layers leading to reduced permeability.

Table 1: Area Irrigated by Different Sources (Million Hectares) in 1999-00

Data Type	Punjab	Sindh	NWFP	Baluchistan	Total
Total Area	13.85	2.52	0.92	0.80	18.09
Water Allocated (BCM)	68.8	59.97	10.80	4.76	144.33
Govt. Canals	3.93	2.39	0.39	0.40	7.11
Private Canals	-	-	0.37	0.08	0.45
Tube wells	2.65	0.13	0.09	0.23	3.10
Wells	0.12	-	0.04	0.02	0.18
Canal & Tube-wells	6.99	-	-	-	6.99
Canal & Wells	0.09	-	-	-	0.09
Tanks	-	-	-	-	-
Others	0.07	-	0.03	0.07	0.17

Data Source: Agricultural Statistics of Pakistan-1999-00

Poor quality saline groundwater can be better utilized through its cyclic use i.e. alternate irrigation of canal and tube well water, which causes less built up of salts in soil profile than conjunctive water application. Both rice and wheat give better yields by cyclic use of saline water with canal water than conjunctive use as irrigation with fresh water flushes the salts added by preceding irrigation of poor quality water. In areas of acute water short supply, wheat can be grown with tube well water, and canal water can be used for growing rice during abundant supply period. The water so applied for rice growing also flushes down the salts. Management of saline-sodic and sodic groundwater by mixing with canal water is one cost-effective option. If availability to canal water is limited then such waters can also be successfully utilized for crop production through its treatment with Sulfurous Acid Generator or Gypsum. Such chemical treatments can also be helpful in reclaiming sodic/saline-sodic soils for better crop yields. Crop growth may further be ensured by adopting furrow and bed planting technology in poor water quality areas, which helps in crop establishment during early growth stages. Adoption of proper water management technologies can help for sustainability of irrigated agriculture without degrading the soils.

There are about 7,00,000 tube wells in Pakistan. Rapid development of groundwater by the private sector is giving rise to the danger of excessive lowering of water tables, impeding threat of secondary salinization due to use of groundwater of marginal quality and intrusion of saline water

into fresh water aquifer. It has been estimated that over 60 percent tube wells in the Pakistan are pumping sodic/saline sodic water.

A profile of groundwater quality is given below:

Qureshi, R.H. and Barrett-Lennard E.G. 1998. Saline Agriculture for Irrigated Agriculture in Pakistan

"About 70% of tubewells in the Indus Plain pump sodic water"

Javaid, Azhar M. 2002. Groundwater Monitoring for Resource Management (Dawn of 11 March 2002)

"About 70 per cent discharge of existing wells is saltish and is playing havoc with soil by developing salinity and sodicity front in fertile soils"

Punjab Directorate of Soil Fertility (PAD)

Total Samples: 75, 737

Fit: 32.4%

Unfit +Marg. Fit: 69.6%

Unfit: 55.2--unfit due to: EC (36%), RSC (11.7%), SAR (3.3%), EC+RSC (12.3%), EC+SAR (13.3%), RSC+SAR (3.5%), EC+SAR and RSC (19.9%)-- total RSC "infected unfit" =47.4%

Recent (2002) Tube well Water Quality Survey of Village Bughiana along Ravi River,

Total Tube well =75: Fit water quality Tube-wells=26, Unfit water quality Tube-wells=49.

Fit Tube wells=34.7, Marginally fit due to RSC=18.7% and unit due to RSC=46.7%

Marginally unit and unfit tube wells due to RSC=65.3%

Unfit due to SAR=84%, unfit due to EC=94.7%

Punjab Soil Fertility Directorate (March, 2002)

(Village near Khudian, Chunian) Middle of the Ravi and Satluj Rivers)

100% unfit-- all Tube wells pump unfit water for irrigation--EC from 158 to 2660 US/cm, SAR from 9.6 to 17.9 and RSC from 4.4. To 9.7

Due to acute shortage of good quality irrigation water for crops, sweet water is becoming a scarce resource because of its decreasing availability. Dependence upon marginal/poor quality groundwater has been increased due to shortage of canal water for the last three years. Application of saline-sodic/sodic water results in accumulation of salts in soil, increased soil pH, and affects soil fertility through reduced availability of essential nutrient elements.

Use of sulfurous acid generator is an appropriate measure on site treatment of sodic/saline sodic water. It takes small quantity of saline-sodic/sodic water from intake pipe, treats it with sulfurous acid in its mixing chamber, and then discharge treated water through outlet pipes. The water so treated can be applied directly to the fields. The Sweet Water Farming Inc, USA, has fabricated the Sulfurous Acid Generators that have been tested extensively in U.S.A., Mexico, Morocco, Saudi Arabia and Pakistan. In Punjab, Sulfurous Acid Generator was tested for rice, wheat, and sugarcane crops. The results of different studies conducted world-over identified following benefits of the Sulfurous Acid Generator:

- Reduces pH of irrigation water and soil
- Decreases the degree of sodicity in irrigation water
- Reduces build up of salts in soil profile
- Increases infiltration rate of soil
- Improves physical condition of soil
- Activates soil Calcium to replace Sodium from clay complex

- Makes Calcium available as nutrient
- Eliminates the necessity of deep plowing, mixing and abundance of freshwater associated with gypsum application
- Provides faster way of reclamation of soils

Sulfurous Acid Generators are now being manufactured in Pakistan under the license of the Sweet Water International, Inc., Utah, USA near Lahore. The water treated with the sulfurous acid can treat alkaline water (sodic or saline sodic) and or having pH value above 7 and Residual Sodium Carbonates (RSC) more than 1.25. Irrigation with treated water helps in managing root zone salinity for utilization of these soils for crop production.

With Sulfurous Acid Generator treatment, sodic/saline-sodic groundwater resources can be utilized for higher crop production besides reclamation of sodic and saline sodic soils as given in table 2. Its use can be promoted through participatory approach, whereby farmers may share cost incurred on procurement of plant, its installation, operation, and maintenance.

Table 2: Impact of Use of Sulfurous Acid Generator Treated Water on Yield of Crop

	Y1	Y2	Yield Increase Y1 to Y2
WHEAT			
Irrigated with untreated water:	1042	1095	5%
Continuous Irrigation with SSG-treated water:	1417	1855	31%
Yield Improvement-Treated vs.non treated:	36%	69%	
RICE			
Irrigated with untreated water:	931	977	5%
Continuous irrigation with SSG-treated water:	1673	2035	22%
Yield Improvement-Treated vs. non treated:	80%	108%	

It is suggested that we should use Resource Conservation Technologies such as Bed and furrow planting, W/C rehabilitation/lining, Laser Land Leveling and zero tillage as ways to create conducive conditions for an effective conjunctive use of ground and surface water resources.

BED AND FURROW SYSTEM

Technology of raising row crops on beds and furrows is gaining popularity amongst the progressive farmers, mainly because the cost of crop production is considerably reduced as a result of water saving and other benefits. Bed shapers are used behind the tractors to form furrow-beds to sow row crops. Some of the advantages associated with furrow-bed-irrigation technology of crop production are:

- Minimum tillage/seed bed preparation reduces over all energy requirements;
- Savings of about 40 percent irrigation water;
- Reduced chances of plant submergence due to excessive rain or over irrigation;
- Lesser crusting of soil around plants and, therefore, more suitable for saline and sodic soils;
- Adaptable for various crops without changing basic design/layout of farm;
- Enhanced fertilizer use efficiency due to local application; and
- Minimum chances of lodging of crops

In view of the above benefits, Bed and Furrow planting of cotton has gained acceptance and popularity amongst farmers in the Punjab during the recent years. Adoption of cotton with bed and furrow shaper has been increased from 500 acres in 1997-98 to 2.00 million acres in 2000-01.

Bed and Furrow plantation technology for wheat has been introduced in the country with the assistance of PARC, Massey University, New Zealand and CIMMYT through Rice-Wheat Consortium of the Indo-Gigantic Plains and was successfully tested during last years in Punjab at different sites on farmers' fields. M/S Green Land Engineering, Daska, has locally fabricated and further refined the planter and equipment has since been released for sowing of wheat, rice, maize, sunflower and vegetables. This technology will be helpful to enhance water productivity and reduce the cost of production of wheat. It is, therefore, imperative to refine this technology and disseminate amongst the farming community to cope with current water crisis.

REDUCING CANAL IRRIGATION LOSSES

The rehabilitation/lining of canals/distributaries and minors come under the purview of provincial Irrigation and Power Departments, whereas rehabilitation of watercourses at farm level is being carried out by the Water Management wings of Agriculture Departments in the provinces.

The results of different studies carried out on irrigation systems of the Indus basin have shown that the major part of the water, which is delivered at canal outlet (mogha), is not fully consumed by the crops. The combined effects of leakage, wastage, and seepage amount to about 40 percent losses of water in the watercourse system. To curtail these huge losses in the watercourses, government of the Pakistan launched country wide On Farm Water Management Program during 1976-77. So far, about 42,000 watercourses comprising more than 150,000 kilometers of earthen improvement, 30,000 kilometers of brick lining, and installation of over 1.5 million water control structures have been improved under the program.

Different evaluation studies regarding OFWM projects indicate significant benefits accruing from implementation of OFWM activities. Measurements have determined reduction in water losses up to 53 percent and increases in delivery efficiency to the tune of 38.5 percent. The resulting increases in cropping intensity have been reported nearly 20 percent, and overall increases in crop yields have been estimated around 24 percent. According to an estimate, 243-Acre Feet of water are saved with improvement of a watercourse per year. As such, about 10 Million-Acre Feet (MAF) of water is being saved annually through rehabilitation/lining of 42,000 watercourses.

PROMOTION OF LASER LAND LEVELING SERVICES

Abdul Sattar et al., 2001 reported that precisely leveled fields at cotton research station, Vehari have shown about 27% saving in irrigation water. They also observed that precision land leveling minimizes the deep percolation and uneven storage of irrigation water in soil profile. Hence, it should be adopted to contain drainage problem and to save precious water resources and foreign exchange involved in drainage installations [5]. Different other studies have indicated that a significant (20 to 25%) amount of irrigation water is lost during its application due to uneven fields and poor farm designing. This leads to over-irrigation of low-lying areas and under-irrigation of higher spots, which results in accumulation of salts in such areas. Over-irrigation leaches soluble nutrients from the crop root zone, makes the soil less productive, and degrades groundwater quality. Moreover, lay out of most of the farms is based on traditional flood basins (Khal-Kiari System)

comprising of a number of unwanted dikes and ditches covering a length of over two kilometers in each square. The fields being not properly leveled, cause wastage of land, result in low irrigation efficiencies, and ultimately lesser yields are resulted than the potential. By providing appropriate land farming services to the farmers i.e. surveying, farm planning, farm designing/layout, precision land leveling, introducing improved irrigation methods e.g. borders/furrows, water scheduling etc., it has been observed that such a package [6] can:

- (i) Reduce the time of irrigation and amount of water required by up to 50 percent, results in uniform seed germination, and even distribution of soil moisture and fertilizer to the crops;
- (ii) Reduce the number and length of field borders and ditches and can, accordingly, increase the irrigated area by about 2% and reduce watercourse length up to 60 percent; and
- (iii) Can increase yields as much as 25 percent.

ZERO TILLAGE

With the help of zero-tillage technology, wheat crop in the rice-harvested fields can be best established. It allows utilization and conservation of antecedent soil moisture, time saving due to early planting, and minimize yield losses attributed to soil structural break down under continuous cropping practices. Moreover, it results in water savings, reduction in production costs, and increased wheat yields. The technology has been successfully tested in the paddy areas of the country. Impact assessment of conservation tillage technology (zero tillage) was accordingly conducted by IWMI Pakistan during Rabi 1998-99[7] and it was observed that conservation tillage technology:

- Saves the cultivation cost to the tune of Rs. 500-800 per acre in case of small farmers and Rs 1000-1500 per acre in the case of medium to large farmers.
- Assists early sowing of the wheat crop.
- Saves 30-50 percent irrigation water in the case of first irrigation after sowing and 15-20 percent in subsequent events.
- Reduces weed germination up to a certain extent.
- Improves soil fertility.
- Enhances water and fertilizer use efficiency.
- Accelerate decay process of rice stubble, which improves soil microbial activities.
- Increase wheat productivity in the range of 15-20 percent, if properly implemented.

The popularity of zero tillage technology can be recognized with the broad acceptance of farmers under OFWM activities. During 1996-97 with the help of five zero tillage drills fifty acres of wheat was sown with zero tillage at farmers' fields. While during the last six years 1100 zero tillage drills have been bought by farmers and wheat has been sown on 1,93000 acres during Rabi 2001-2002. It means, On Farm Water Management has succeeded to save rupees two hundred millions farmers' money as input in wheat cultivation through zero tillage technique during 2001-2002 only in one year. In Pakistan five million acres are sown under rice wheat cropping pattern. The goal of On Farm Water Management is to approach 45 thousand villages and five million farmers for introducing the zero tillage technology and saving about 50 billion rupees per annum.

RECOMMENDATIONS FOR THE USE OF POOR QUALITY GROUNDWATER THROUGH CONJUNCTIVE WATER MANAGEMENT

Conjunctive water management using treated poor quality groundwater with sulfurous acid and by adopting furrow and bed planting may enhance crop productivity.

Reducing irrigation losses at canal, distributory and Water course level, promotion of zero tillage and Precision land leveling should be accelerated for augmenting inadequate surface water and using poor quality groundwater.

Research, education, extension and water resource management institutions have to be further strengthened for efficient resource conservation, management and development of water resources.

Existing laws, rules and regulations, if rigorously enforced, can help in resource conservation. Legislative measures can, however, work properly in an educated society. Till that time, more emphasis should be on mass awareness and participatory approach to planning and decision making for a sustainable agriculture.

Resource Conservation Technologies including sulfurous acid generator, furrow and bed planting, watercourse improvement, precision land leveling and zero tillage need to be highly emphasized. Government should provide technical assistance and backup support for their adoption amongst the farmers.

REFERENCES

Abdul Sattar, A. R. Tahir and F. H. Khan, 2001. Impact of precision land leveling on water saving and drainage requirements. Proceedings of the 2nd National Seminar on " Drainage in Pakistan" UAF. April 18-19, 2001.pp 91-97.

Bhasker, R.K., Calvin G. Clyde and Rangesan Narayanan.1983. Conjunctive Water Use Planning with Water Quality Constraints in Tooele Valley, Utah. Water Resources Planning Series UWRL/P-83/07.

Chaudhry, M. T., J. W. Labadie, W. A. Hall, and M. L. Albertson. 1974. Optimal conjunctive use model for Indus Basin. Proc. Amer. Soc. Civil Engineers, J. Hydraulic. Div. 100(HY5): 667-687.

Halcrow Rural Management 1991. Minutes April 1991, OECF assisted OFWM Project. Ministry of Food, Agriculture and Cooperative, Government of Pakistan.

Impact of Resource Conservation (zero tillage) Technology on Wheat Production. Directorate General Agriculture (Water Management), Punjab, September-1999.

Ramzan, M.Ch. 2000. Groundwater Quality Variations in Pakistan. Proceedings of Regional Groundwater Seminar held at Islamabad, October 9-11, 2000.

Water and Power Development Authority 1996. Conjunctive Use of Fresh and Saline Water for Irrigation. International Waterlogging and Salinity Research Institute. Publication No. 168.

Technical Constraints to Deep Groundwater Pumping for Conjunctive Water Management in the Coleambally Irrigation Area, Australia

Evan Christen¹ and Shahbaz Khan²

ABSTRACT

Coleambally Irrigation Area (CIA) of Australia has a complex multi-layered aquifer system. The upper shallow aquifers consist of discontinuous sand units, which are inter bedded with sequences of silts and clays. The shallow aquifer salinity is ranges 1,000 to more than 20,000 $\mu\text{S}/\text{cm}$. The silt and clay sequences act as aquitards overlying the deeper, more permeable aquifers, which contain fresh water with salinity less than 1,000 $\mu\text{S}/\text{cm}$.

The conjunctive management of water involves efficient use of surface water, additional irrigation supplies from the deep aquifers, and possible management of shallow watertables through shallow or deep pumping. The major constraint to pumping from the deep aquifers is the risk of enhanced leakage of the overlying saline waters from the shallow aquifers through aquitards into the deep aquifers. A groundwater modelling investigation was undertaken to assess safe deep bore locations and rates of pumping to supply additional irrigation supplies without increasing the deep aquifer salinity. The study also analysed whether deep pumping could play a significant role in watertable and salinity control at the surface. The results found that judicious pumping could be undertaken with only small increases in the deep aquifer salinity; however, the impact on watertables was negligible. Thus deep groundwater pumping can provide additional suitable water supplies but cannot be an effective watertable/salinity control measure in the CIA.

INTRODUCTION

Coleambally Irrigation Area (CIA) is part of the Murray Darling Basin and is located within the lower part of the Murrumbidgee River Catchment in southeastern Australia (Figure 1). The CIA comprises of an area of 79,000 ha south of the Murrumbidgee River in the Lower Murrumbidgee region of NSW. The area was originally settled in the 1840s and was predominantly used as pastoral land (Coleambally Land and Water Management Plan 1996). The groundwater pressures in the CIA remained relatively unchanged until the advent of irrigation in the 1960s when 333 farms were allocated 79,000 ha to form the CIA. The main irrigated enterprises in the area are rice, sheep/annual pastures, winter crops, soybeans and some horticulture. By far the most prevalent land use is rice. Rice is grown under pounded conditions, thus use of much larger volumes of water per hectare (~14 ML/ha) than other crop types (Wheat 3.6 ML/ha, Soybeans 9.5 ML/ha). Average total

¹ Irrigation and Drainage Engineer (Research), CSIRO, Land and Water, Griffith, NSW, Australia

² Senior Scientists, CSIRO, Land and Water, Griffith, NSW, Australia

annual rainfall in the Lower Murrumbidgee region decreases slightly from east to west and lies in the range of 400-450mm/yr. The annual evaporation varies between 1500-2000mm.

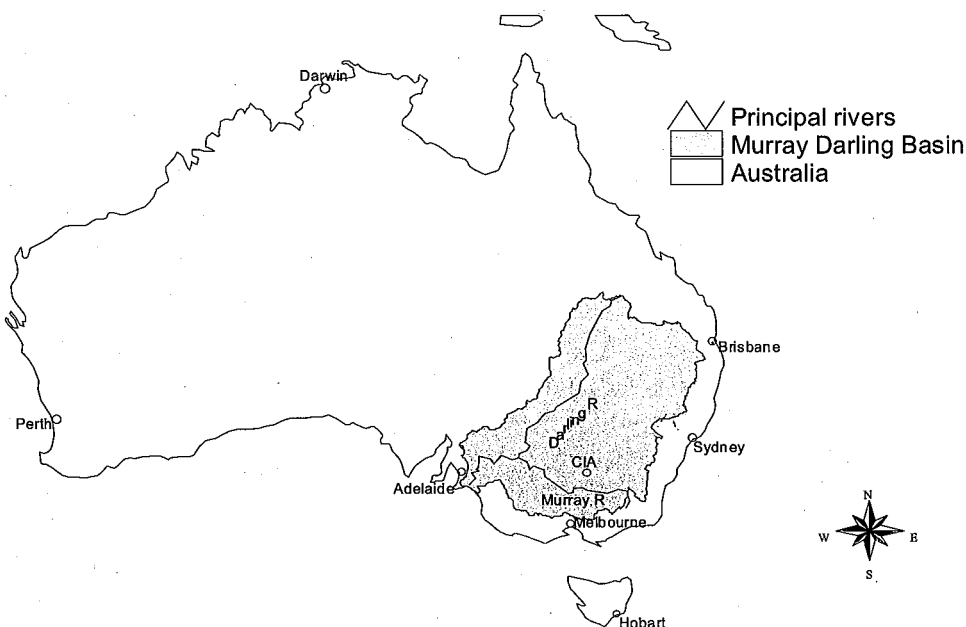

Figure 1: Location of Coleambally Irrigation Area

The average surface water supplies to the CIA are around 400 GL/yr. The water balance estimates for CIA (Coleambally Land and Water Management Plan 1996) suggest that the total amount of water entering the shallow groundwater system is about 54 GL/yr (average over 1985-1995). Of this, 14 GL/yr moves away from the area laterally, and 26 GL/yr flows downwards into the deep groundwater system. The remaining 14 GL/yr is the volume assumed to cause rising groundwater levels. The downward flow to deeper aquifers may result in higher groundwater potentials in deeper aquifers (in the absence of significant pumping) and therefore reduced potential gradients between shallow and deeper aquifer systems. The reduced groundwater gradients between the shallow and deep aquifers may result in decreased downward flows in future and therefore a greater rate of watertable rise for similar recharge.

Prior to irrigation development, water tables in the area were around 15-20 m below the ground surface. Since irrigation began water levels have risen at rates up to 1m /year with the effect that now a large groundwater mound exists beneath the CIA. In 1999 around 2/3rd of the CIA had water tables within 2 m of the ground surface. Rising water tables with their associated effects of waterlogging and soil salinization are threatening the agricultural productivity and environmental sustainability of the area. Conjunctive water management in CIA can involve measures, which can reduce recharge (efficient use of irrigation water) or can induce discharge (e.g. shallow or deep groundwater pumping) from the groundwater. Groundwater pumping and reuse is a possible way of water table control. One major constraint in the groundwater use is its quality. Water quality in the shallow aquifers is extremely variable (1,000-30,000 $\mu\text{S}/\text{cm}$), and in general, shallow groundwater is

of too poor a quality to be considered as a resource. Deep groundwater, however, are generally of a good quality (500-700 $\mu\text{S}/\text{cm}$). Deep groundwater pumping thus can serve both as resource and water table/salinity control. The deep groundwater can be used conjunctively with the surface water to improve the environmental sustainability of the CIA. This paper describes a modelling study undertaken to explore the feasibility of deep groundwater pumping for conjunctive water management in the CIA.

HYDROGEOLOGY OF CIA

The apex of the Murrumbidgee alluvial fan is situated near Narrandera (Wooley and Williams, 1978). The sediments of this fan increase in thickness in a westerly direction from the eastern flank of the basin. Brown and Stephenson (1991) categorised these sediments based on age and type of deposition into three distinct units, these being Renmark, Calivil and Shepparton formations.

The Renmark formation is the oldest stratigraphic unit and directly overlies the pre-Cainozoic bedrock. It was deposited during the Palaeocene to Middle Miocene ages. The base of the Renmark formation consists of light brown quartz sand (Warina Sand), the upper sequence consists of more argillaceous and carbonaceous sediments (Olney Formation). It is estimated that 30 to 50% of the Renmark formation is comprised of sand. The horizontal hydraulic conductivity of the Renmark formation averages between 10 and 30 m day^{-1} but it can be as high as 100 m day^{-1} .

The Calivil formation was deposited during the late Miocene to Pliocene ages and consists predominantly of pale grey coarse to granular quartz sand, with lenses of kaolin and carbonaceous clay. It is estimated that this formation consists of 50 - 70% sand and gravel. The average hydraulic conductivity of the Calivil formation estimated at Darlington point is approximately 130 m day^{-1} .

The Shepparton formation was deposited from the Pliocene age until present day. It consists of a matrix of clay, silt and silty clay, with lenses of fine to coarse sand and gravel. The clay is silty, variegated, mottled and red brown, yellow or white in colour. The proportion of sand in this formation is highly variable, but typically in the range of 10 - 30%. The geology of the Shepparton formation is complicated due to prior stream deposition, which resulted in localised concentrations of coarse grade sands and connections to deeper aquifers. Due to the discontinuous nature of Shepparton sand lenses the average hydraulic conductivity is around 2 to 3 m day^{-1} but it may be 25 to 100 m day^{-1} in the more sandy parts.

MODELING METHODS

Sustainable conjunctive water management is constrained by surface and groundwater availability and quality. If too much water enters the groundwater system then the land could be waterlogged, if too much water is removed from the groundwater system then the groundwater resource would be depleted and may be degraded by salt intrusion. The objective of sustainable conjunctive water management is to find an optimal combination of groundwater and surface water use that augments irrigation supply and also controls salinization and waterlogging.

In order to determine sustainable levels of surface water and groundwater use at a regional scale, the response of the groundwater system to changes in recharge rates and groundwater pumping rates needs to be determined. The best method of determining how a variable groundwater system will behave under variable conditions is to model the system. The MODFLOW (McDonald and

Harbaugh, 1988) model of the CIA, already developed by CSIRO (Enever, 1999, Khan et al, 1999), was improved by refining its calibration and adding solute transport options. Historical water salinity data was collected, collated and analysed and a MT3D (Zheng, 1990) solute transport model was developed and linked with the regional groundwater model. This combined regional groundwater and solute transport model was used to predict the response of the groundwater system to the deep pumping in terms of head and salinity changes. With the constraints of acceptable drawdowns and salinity changes a number of scenario were run to decide the possible location (s) of deep bore(s).

Figure-2 shows the layout of the finite difference grid used for the CIA model. The grid consists of 60 columns and 66 rows (1.25 km square mesh) and encompasses an area of 6,187.5 km². The eastern edge of the grid was set parallel to the bedrock. The southern edge was positioned to include Yanco Creek. The northern edge of the grid was set to include the Murrumbidgee river and was positioned far enough north of the Murrumbidgee to include the areas around Darlington Point to incorporate groundwater pumping over the last ten years. The western edge of the grid was set several kilometres outside the western limit of the CIA to minimise effects of boundary conditions on the groundwater regime in the CIA.

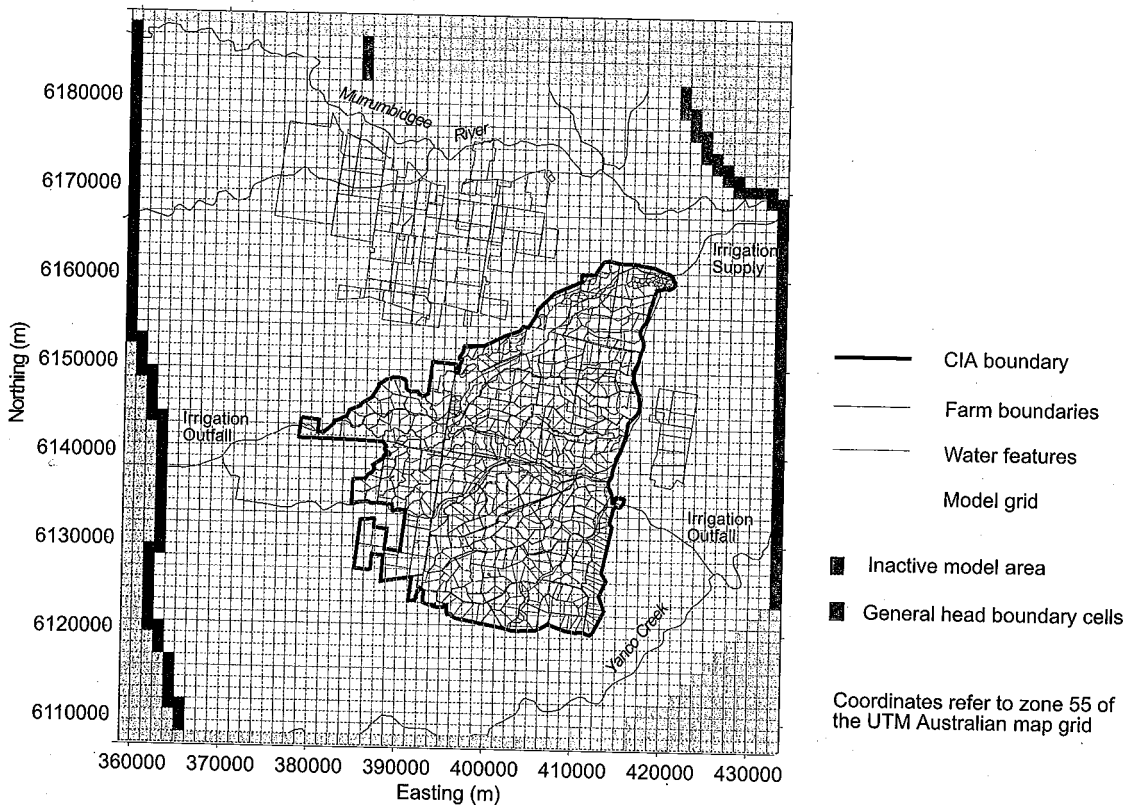

Figure 2: CIA model grid

The four layers represented in the CIA model were defined by the stratigraphic breakdown shown in Figure-3. The Shepparton formation was further divided into two separate model layers in order to improve the model's treatment of the vertical flow processes in the shallow aquifers. Kriging was

used in the interpolation of all spatial data sets in the CIA model, using Surfer (Golden Software, 1994).

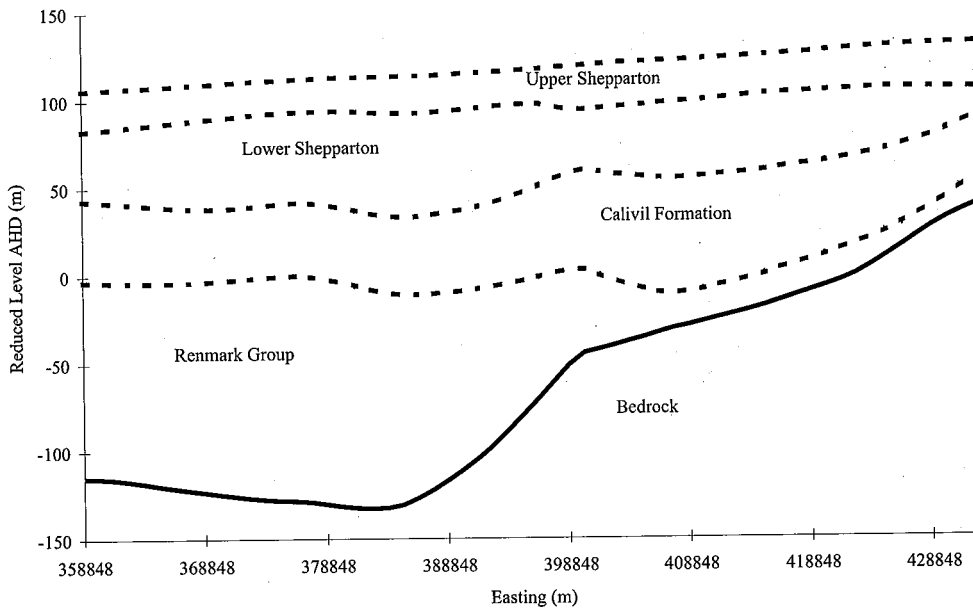

Figure-3 East to west transect through Northing 6149562 (m)

The CIA model simulation period was March 1985 to March 1995 using monthly stress periods and 10-day time steps. A trial and error procedure was adopted to calibrate the hydraulic parameters and recharge to match piezometric water level hydrographs. Forty-three hydrographs were used to calibrate the CIA model, 14 in the Upper Shepparton, 12 in the Lower Shepparton, 8 in the Calivil and 9 in the Renmark. Figure-4 shows old and new calibration of the model at one of piezometers in the Calivil formation. Details of model recalibration can be found in Prasad et. al. (2001).

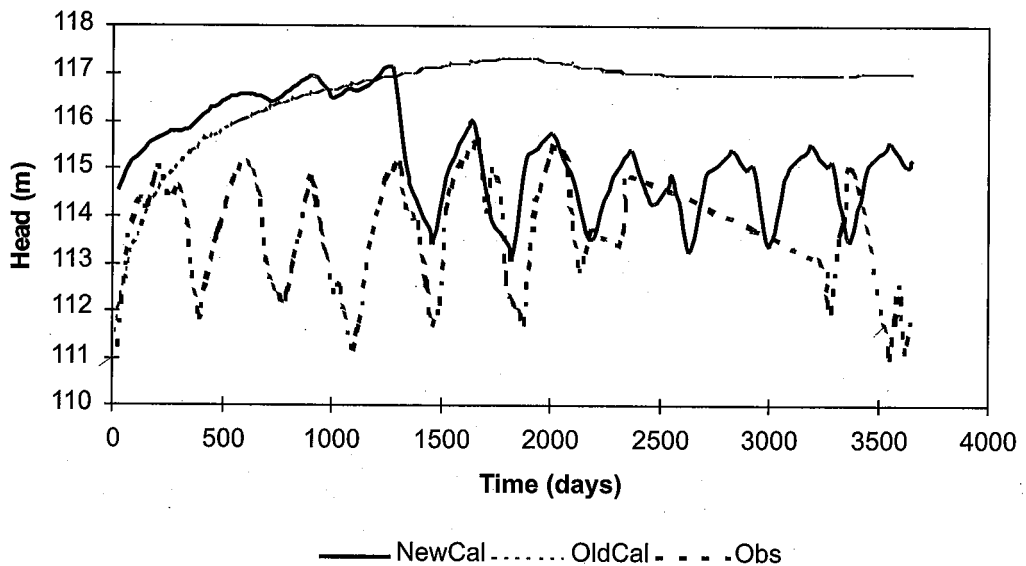

Figure 4 Old and new calibration at Piezometer GW030282_2 in Calivil Formation

Salinity Data Used in Transport Model

In 1973, major part of the CIA had shallow groundwater salinity less than 4000 $\mu\text{S}/\text{cm}$, which increased up to 8000 $\mu\text{S}/\text{cm}$ over more than half of the CIA with some pockets showing salinity as high as 12000 $\mu\text{S}/\text{cm}$. Salinity in 1984 appears higher than in 1987, which might be more due to sampling different piezometers than any physical trend. The increase in salinity in the Lower Shepparton Aquifer is attributed to gradual rise to water table due to increase in recharge caused by irrigation.

The data in the Calivil formation is very scarce and are not really representative of the year, which they apparently refer to. As compared to the shallow layers, the water quality in the Calivil Aquifer is very good (around 700 $\mu\text{S}/\text{cm}$) and has not changed much.

The 1985 salinity level (< 650 $\mu\text{S}/\text{cm}$) shows that the Renmark Aquifer salinity is lower than that for the Calivil Aquifer.

Initial Conditions for the Solute Transport Model

As the flow model has been developed and calibrated for the period March 1985-March 1995, the March 1985 salinity was chosen as the initial conditions for the solute transport model. The initial condition for all layers was generated by Krigging the 1985 salinity data by the SURFER (Golden Software, 1994) software.

DEEP GROUNDWATER PUMPING SCENARIOS

Around 46000 ML /year is currently being pumped from the deeper aquifers in the modelled region. This volume includes approximately 6000 ML /year being pumped by a deep bore located within the CIA and owned by the Coleambally Irrigation Cooperative Limited (CICL). The CICL has an additional allocation of around 4000 ML/year from the deeper aquifer. The long-term impact of pumping from this additional allocation of water from deeper aquifers on salinity levels and drawdown in deeper aquifers and on drawdown in shallow aquifers is determined to help decide suitable location(s) of deep bore(s). The regional flow and solute transport model were run a many times to evaluate a number of feasible pumping scenarios. The aim was to maximize the drawdown in shallow aquifers with the constraint that quality of water coming from the deep groundwater well does not deteriorate excessively and also the instantaneous drawdown in deeper layers remains within some permissible limits. The flow and solute transport models were run in a forecast mode for 20 years starting 1995, with the new bore(s) introduced in August 2000 and operating for 8 months between August and March every year. Instead of using modelled output of 1995 as initial condition, the actual piezometric heads and salinity data (where ever available or combination of nearby years) were used to generate initial conditions. This was done to avoid the accumulation of computation errors. The recharge cycle between 1985-1995 was repeated twice assuming similar irrigation practices and meteorological conditions.

Figure 5 describes the locations of well (s) used for different scenarios. Table-1 shows the proportion of discharges assigned to the well from the Calivil and Renmark formations in a particular scenario. In all scenarios the total pumping volume remained constant at $Q = 4000$ ML/year. In scenario 1, one well was placed in the Calivil layer at around the centre of the southern district of the CIA. In scenario 2 the well was located at the same place as in scenario 1 but the pumping volume ($Q = 4000$ ML/year) was distributed between the Calivil and Renmark layers in the 30:70 ratio. In scenarios 3 and 4, the well was located near the eastern boundary of the CIA in the southern district. The difference between the scenario 3 and 4 was in pumping percentages from the Calivil and Renmark, whereas in scenario 3, the total pumping (100%) was from the Calivil layer alone. In scenario 4 pumping was distributed between Calivil and Renmark layers in the ratio of 50:50. In scenarios 5 and 6, two wells, one in the middle of the Southern CIA (at the same location as scenarios 1 and 2) and another near the northwest corner of the southern CIA were used. Both wells were assigned half of the total volume of annual allocation ($Q = 2 \times 2000 = 4000$ ML/year). The difference between scenario 5 and 6 was that the abstraction volume distribution at both locations between the Calivil and Renmark was in the ratio of 30:70 in scenario 5, and it was in the ratio of 50:50 in the scenario 6. All these scenarios were developed by trial and error approach to achieve desired drawdown in upper aquifers and keep salinity changes within acceptable limits.

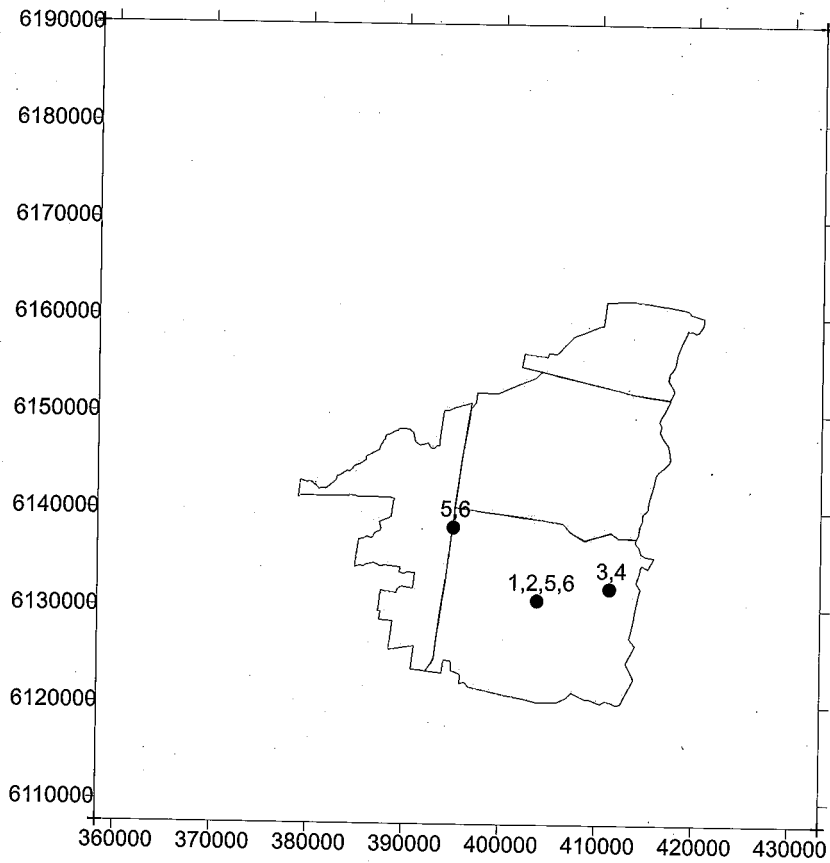

Figure-5 Location of deep well in different scenarios

Table 1. Percentage volumetric contribution of Calivil and Renmark in different scenarios. For * marked wells, volumes are equally distributed between two locations.

Scenario number	No. of wells	Q (ML/year)	Contribution (%) of Calivil	Contribution (%) of Renmark
1	1	4000	100	-
2	1	4000	30	70
3	1	4000	100	-
4	1	4000	50	50
5	2*	4000	30	70
6	2*	4000	50	50

RESULTS

In this section only a brief description of results is provided. Detailed results can be found in Prasad et al (2001).

Scenario-1

The hydrograph in the Calivil showed that there was an excessive local drawdown fluctuation (> 100 m) in the Calivil formation and the deep groundwater quality rapidly deteriorated (Figure 6). This scenario was considered infeasible.

Scenario 2

The spatial distribution of drawdown in the Calivil and Renmark formations showed that almost the entire CIA would have a minimum relative drawdown of 0.2m. The maximum relative drawdown at the well in these two layers was between 30-38 meters. The drawdowns, however, in these layers were cyclic i.e. aquifers more or less tend to fully recover as evident from their hydrographs. The residual drawdowns in these layers were less than 2 m at the end of 15 years of pumping. Thus aquifers were not getting mined. The residual drawdown in shallow aquifers at the end of 15 years of pumping was around 0.2 m. The effect of deep pumping on the drawdown in the shallow aquifers was although small but was indicative of a favourable long-term outcome i.e. enhanced downward leakage.

The temporal variation of salinity showed that the salinity of Calivil Aquifer would increase as a result of pumping at a rate of around $33 \mu\text{S}/\text{cm}/\text{year}$. Given the availability of surface water for dilution, this increase may be acceptable from irrigation point of view.

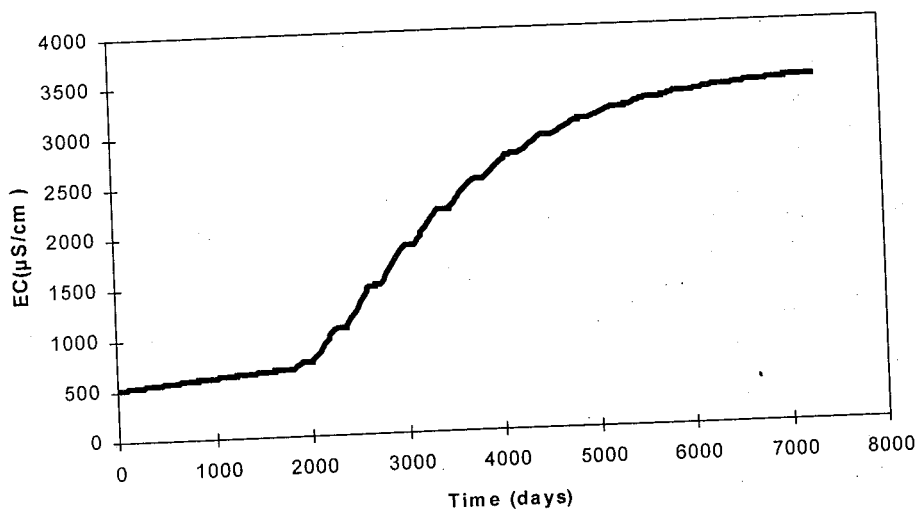

Figure-6 Temporal variation in Calivil Salinity at the pumping site for scenario-1.

Scenario 3

Almost the entire CIA would be within the area of influence of a minimum relative drawdown of 0.2m in the Calivil and Renmark at the end of 15 years of pumping. However, the area of influence is smaller compared with the scenario 2. The residual drawdown in the Calivil Aquifer would be less than 2 m at the end of 15 years of pumping. The drawdowns in the shallow aquifers are concentrated around the eastern boundary of the CIA. The maximum shallow aquifer drawdown at the end of 15 years of pumping was between 2-5 m. The salinity of deeper aquifers would increase

as a result of 15 years of pumping by around 450 $\mu\text{S}/\text{cm}$ giving a moderate increase rate of around 30 $\mu\text{S}/\text{cm}/\text{year}$.

Scenario 4

Results of scenario 4 were similar to that of scenario 3.

Scenario 5

The Calivil and Renmark layers would experience a minimum relative drawdown of 0.2m over almost the entire CIA. The majority of areas in the southern and western CIA would experience 2-5 m drawdown. The maximum relative drawdown at the first well location in the deeper aquifers was between 17-20 meters and at the second well location was between 17-20 meters. These drawdowns were cyclic, as aquifers more or less tend to fully recover. The maximum drawdown in the shallow aquifers after 15 years of pumping was between 1-2 m. At the first well location, net increase in groundwater salinity over 15 years of pumping was around 120EC and at the second well location was around 160 $\mu\text{S}/\text{cm}$. The net rate of increase in salinity due to the pumping was small 8-11 $\mu\text{S}/\text{cm}/\text{year}$.

Scenario 6

Results of scenario 6 were similar to those of the scenario 5.

Relative Upper Aquifer Drawdowns

A summary of cumulative drawdown and area of influence in shallow aquifers is given in Figure-7. The drawdown area curves shown on these graphs are the spatial average values. It is evident that scenarios 3 and 4 are causing greater lowering of water table over a smaller area than scenarios 5 and 6, which are identical. The scenarios 5 and 6 tend to lower water table by smaller amounts but over much larger area. The scenario 2 is placed in between the two extremes.

Figure-7 Shallow aquifer drawdown versus area affected for different scenarios

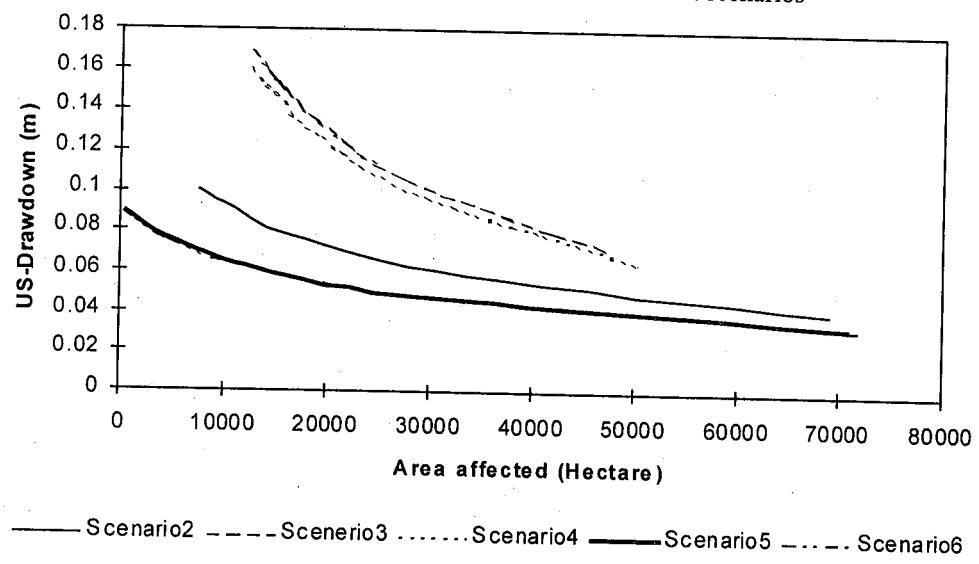

CONCLUSIONS

Groundwater pumping from two well locations (Scenario 5) appears to provide best option for the long-term sustainability of water quality in deep aquifers but offers little advantage in terms of water table control. Total pumping from one well (scenarios 3 and 4) appears to be more effective in controlling water table over a smaller area, but it can result in greater degree of quality deterioration. The scenarios 5 and 6, where two wells are employed, have more operational flexibility than any other scenario, which employ only one well. A better quality of water was obtained in case of pumping from both the Calivil and Renmark formations rather than pumping from the Calivil alone. Though the scenarios 5 and 6 result in a very little water table control, it is recommended, because of the long term quality sustainability of the deeper aquifers, that pumping from the deeper aquifers should be treated as additional irrigation supply rather than a true water table control measure. The water table can be better controlled by improving water use efficiency and exploring shallow drainage options.

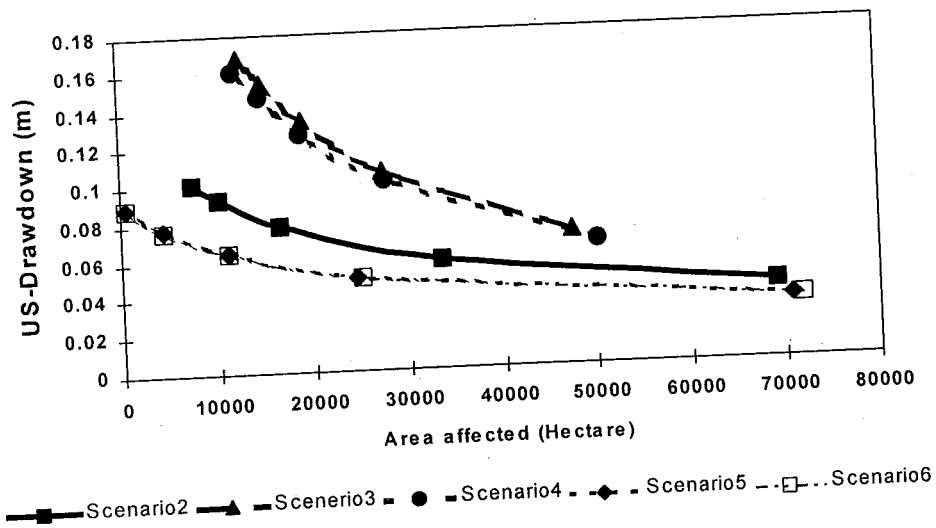

REFERENCES

- Brown, C. M and Stephenson, A. E., 1991. Geology of the Murray Basin Southeastern Australia. Bureau of Mineral Resources, Australia, Bulletin 235.
- Chiang, W. & Kinzelbach, W., 1996. Processing Modflow: A simulation system for modelling groundwater flow and pollution.
- Coleambally Irrigation Corporation (1996) Land and Water Management Plans.
- Enever, D. (1999). Coleambally groundwater simulation model, CSIRO Land and Water Consultancy Report.
- Golden Software. (1994). Surfer version 5. Golden Software, Golden, Colorado.

- Khan, S., Merrick, N. P., Christen, E. and Tiwari, A., 1999. Review of Regional Groundwater Model of CIA in Proc. Murray Darling Basin workshop, Griffith, 179-185.
- McDonald, M.G. & Harbaugh, A.W. (1988). MODFLOW: A modular three-dimensional finite-difference groundwater flow model. U.S.G.S., Scientific Publications, Washington.
- Prasad, A, Christen, E.W. and Khan, S. (2001). The potential role for deep groundwater pumping in the control of irrigation induced salinity in the Riverine Plain: A case study of the Coleambally Irrigation Area. Technical Report 01-01.
- Wooley, D. R. and Williams, R. M., 1978. Tertiary Stratigraphy and Hydrogeology of the eastern part of the Murray Basin, NSW in Hydrogeology of the Riverine Plain of SE Australia, ASSS Conf. Griffith.
- Zheng, C., 1990. MT3D a modular three-dimensional transport model, S. S. Papadopoulos & Associates, Inc., Rockville, Maryland.

Improving Institutional Arrangements for Conjunctive Water Use in Australia: A Case Study of the Shepparton, Coleambally and Burdekin Irrigation Areas

Evan Christen¹, Shahbaz Khan² and Ilja van Meerveld³

ABSTRACT

This paper attempts to determine the institutional arrangements required to make effective implementation of conjunctive water management possible to limit salinity problems and to maintain the economic viability of irrigated agriculture in Australia. The institutional arrangements in three irrigation regions in Australia were compared, being the Shepparton Irrigation Region in Victoria, the Coleambally Irrigation Area in New South Wales and the Burdekin Irrigation Region in Queensland. The research was based on literature studies and discussions with people involved in the management of the irrigation areas.

In all three irrigation areas, water is used conjunctively to mitigate or prevent salinity problems and increase the total volume of water available. It can, therefore, increase the production and profitability of irrigated agriculture. Conjunctive water use also improves the timing of water supply in all three areas, as groundwater is also available during periods of channel maintenance. In the Shepparton Irrigation Region and the Burdekin region conjunctive use also increases the quality of irrigation water.

INTRODUCTION

Continued productivity and environmental sustainability of irrigation areas are threatened by both poor water management practices and increasing competition for irrigation water. The long-term productivity in irrigated areas is threatened by a number of environmental sustainability issues, which include over-pumping of groundwater resulting in aquifer depletion and up-coning of the fresh-saline water interface, over-irrigation of surface water resulting in water-logging and salinisation, and the use of marginal to poor quality water resulting in soil salinisation and sodification (IIMI and ACIA, 1997). It is estimated that globally, the irrigation area going out of production each year due to land degradation is approximately equal to new areas brought under irrigation (Ministry of Foreign Affairs, The Netherlands, 1998).

In Australia, problems of rising watertables and soil degradation emerged soon after the establishment of the first irrigation schemes. Now, few irrigation areas are free of problems and all

¹ Irrigation and Drainage Engineer (Research), CSIRO, Land and Water, Griffith, NSW, Australia

² Senior Scientists, CSIRO, Land and Water, Griffith, NSW, Australia

³ Graduate student, University of Greenwich, Australia

indications show that, without major remedial measures, they will get worse (Hallows and Thompson, 1995).

Salinity problems related to irrigation can be addressed through conjunctive management of surface water and groundwater. Conjunctive management is the combined and integrated management of surface and groundwater for optimal productivity and allocation efficiency. Conjunctive water use was developed in the 1960s as a resource management objective to maximise water availability. Other objectives of conjunctive water use as found by Vincent & Dempsey (1991) covers improved availability of water, environmental objectives to reduce waterlogging and salinity, increased production, equity and poverty alleviation objectives, and fiscal objectives to optimise expenditure on rehabilitation and state disengagement from canal irrigation management. It is claimed that conjunctive use of water can contribute to improved agricultural performance, sustainability and equity (Prasad and Verdhen, 1990).

Conjunctive management of multiple sources of water is good in theory, but has not worked well in practice (Vincent and Dempsey, 1991), as there are many difficulties for its implementation. The main difficulty is that the means for actually carrying out effective and sustainable conjunctive water management have not been established. Effective conjunctive water management requires: Effective technologies for controlling surface water applications, waterlogging, groundwater withdrawal, and artificial recharge of aquifers.

Institutional arrangements and rules to control the use of the surface water and groundwater. Institutions include laws and policies, water allocation rules and principles, water markets, management organisations and regulatory organisations.

Information and management tools to enable water managers to manage multiple sources of water (IIMI and ACIA, 1997).

In addition, conjunctive use demands the integration of surface water and groundwater management systems under one planning authority or user group, but in practice, separate authorities often govern surface water and groundwater, and consequently rivalries and poor co-ordination may result. Furthermore, surface water may be owned and managed by the government while groundwater pumps may be privately owned. Hence, regional authorities may have better control over surface water management and pricing than over groundwater, and policies may be ineffective (Vincent and Dempsey, 1991). Moreover, data on different water resources in irrigated areas, where it exists, is often fragmented among various entities, so that effective conjunctive water management is not possible (e.g. Raju et al., 1994 and Murray-Rust and van der Velde, 1994).

THE AUSTRALIAN STUDY AREAS

Three irrigated regions in Australia were chosen for analysis of their conjunctive water management practices. These regions are the Shepparton Irrigation Region (SIR) in the State of Victoria, the Coleambally Irrigation Area (CIA) in the State of New South Wales and the Burdekin region in the State of Queensland (Figure 1). The selection of the regions in three different states was due to the different laws and policies in each state, as under Australian law natural resource management comes under State jurisdiction.

Figure 7. Locality map of the study areas.

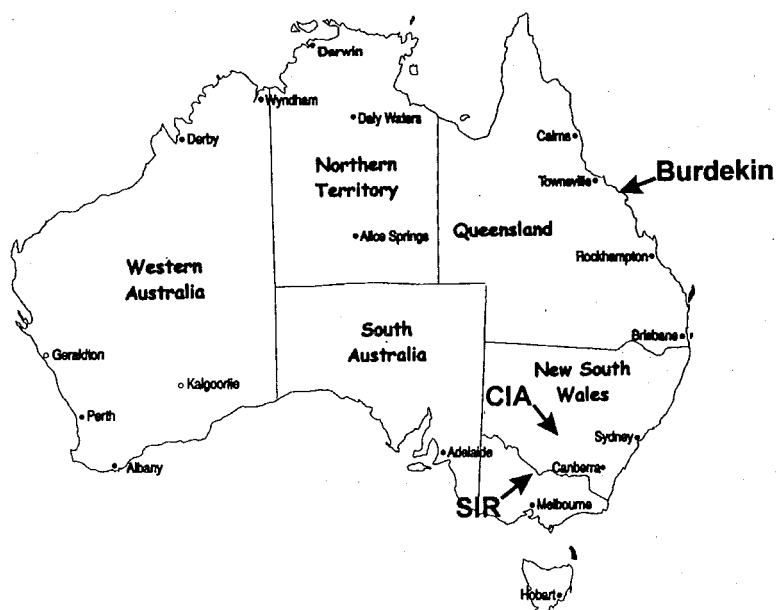

Summaries of the biophysical characteristics of each region are given in Table 1.

Table 1. Characteristics of the study areas:

	Shepparton	Coleambally	Burdekin
State	Victoria	New South Wales	Queensland
Average annual rainfall (mm)	500	400	1,000
Total area (ha)	500,000	85,000	~96,000
Area irrigated (ha)	280,000	~50,000	~70,000
Main crop	Pasture	Rice	Sugar cane
Surface water use (ML/yr)	1,400,000	480,000	300,000
Groundwater use (ML/yr)	45,000	45,698	In the BRIA: 20,000 In the Delta: unknown
Number of inhabitants	98,000	1,384	18,957
Major environmental problem	Waterlogging and salinity	Waterlogging and salinity together with drainage water quality	Sea water intrusion, potential for waterlogging and salinity, impact of drainage water on the wetlands
Type of conjunctive water use	Salinity control and additional supply	Salinity control and additional supply	Additional supply, alkalinity mitigation and prevention of salinity problems and seawater intrusion

Conjunctive water use in the Shepparton Irrigation Region (SIR) is the combined use of surface water and shallow (< 20 m) groundwater. This is promoted by the Shepparton Irrigation Region Land and Water Salinity Management Plan as a salinity remediation measure. The shallow groundwater is saline and has to be shandied with surface water before it can be used. The reuse of groundwater leads to an increase in soil and aquifer salinities and thus may threaten the long-term sustainability of the area.

In the Coleambally Irrigation Area (CIA) deep (>100 m) groundwater is used in conjunction with surface water and is pumped by Coleambally Irrigation Co-Op (CIC), and individual farmers. The Coleambally Land and Water Management Plan promotes deep aquifer pumping as this increases vertical leakage from the shallow more saline aquifer to the deep aquifer and thus helps in providing salinity control. Water pumped by Coleambally Irrigation is mixed with surface water in the supply channel. The deep aquifer is already over-allocated (Personal communication S. Lawson, DLWC). Therefore, an increase in deep groundwater pumping will lead to mining of the finite resource. It is planned that shallow groundwater pumping will take place in the future as well. Part of this water will be reused and another part will be disposed of to the surface drainage system.

The Burdekin region is divided in three management areas; the delta north of the Burdekin river managed by the North Burdekin Water Board (NBWB), the delta south of the Burdekin river managed by the South Burdekin Water Board (SBWB) and the Burdekin River Irrigation Area (BRIA) managed by State Water Projects (SWP).

Conjunctive water use in the BRIA is needed to prevent watertable rise and salinity problems. Conjunctive water use is promoted by SWP by allocating 1 ML of groundwater for each 8 ML of surface water. This 1 ML is the average deep drainage loss. Conjunctive use of surface water and more saline groundwater also prevents soil surface crusts formation caused by the high alkalinity and low salinity of the surface water. Water use on the edge of the irrigation area close to the bedrock increases the inflow of salts from the bedrock and causes groundwater salinisation. Excessive groundwater use in the northern part of the BRIA can also lead to seawater intrusion.

The Burdekin delta is an older irrigation area and used to be dependent on groundwater. In the 1930s and 1960s excessive groundwater pumping led to seawater intrusion events. In 1965 and 1966 the North and South Burdekin Water Boards respectively were established as Underground Replenishment Boards to utilise a part of the flow of the Burdekin River to replenish the delta aquifer and to thereby increase the quantity and improve the quality of groundwater supply. Since the completion of the Burdekin Falls Dam in 1986 surface water is available all year round and the area has become less dependent on groundwater. The water boards now experience problems in obtaining water of low turbidity that can be used for artificial recharge. They promote surface water use because this reduces the need for artificial recharge, as less groundwater is pumped and surface water use spreads recharge over a large area. The use of surface water on the coastal margins pushes the saltwater wedge to areas that did not experience salinity problems before. Conjunctive use in areas near the bedrock leads to an increase of saline flow from the bedrock and groundwater salinisation.

ANALYSIS OF CONJUNCTIVE WATER MANAGEMENT IN THE IRRIGATION AREAS

Bio-physical Conditions

Shepparton Irrigation Region

The Shepparton Irrigation Region is located in northern Victoria at the confluence of the Goulburn and the Broken Rivers. It is one of the largest irrigation areas in Australia both in area irrigated and volume of water used.

The SIR totals about 500,000 ha with some 487,000 ha of farm holdings. Of this, 430,000 ha are suitable for irrigation and about 280,000 ha is irrigated any year. Of the irrigated area, the largest proportion is used for pasture production for dairying (80%) and a small proportion is used for high value perennial horticulture crops (3%). The size of properties and water use varies widely. The impact of waterlogging and salinisation is not uniform over the landscape but is dependent upon the landform, which affects soil type and natural drainage conditions. The implemented solution to waterlogging and salinity problems include the development of a surface drainage network, tile drains for horticulture and shallow groundwater pumping for pasture and horticulture also. Water from groundwater pumping is disposed of, if it is of low quality or, used conjunctively with surface water if it is of good quality.

Evidence so far is that only a small part of the local recharge finds its way, by deep seepage, to the deeper aquifers. Most of the local recharge is dissipated as watertable rises and groundwater discharges associated with flows in the shallow aquifer. Prior to irrigation, watertables in the Shepparton Region were some 25 metres below the surface. In 1997, the long-term watertable trend for the region was still upward (Goulburn-Murray Water, 1997a). The area where the groundwater table is within 2 m from the soil surface was about 160,000 ha in 1989; this is predicted to increase to an estimated 247,000 ha in the year 2025. This would have serious impact upon the productivity of the region. To combat this problem, the Shepparton Irrigation Region Land and Water Salinity Management Plan (SIRLWSMP) was developed in the late 1980s and had the government's endorsement for implementation in 1990.

Water right available per irrigated hectare averages 3.57 ML/ha. Average actual application rate of surface water supplies is around 5.5 ML/irrigated ha/yr or about 3.5 ML/ha/yr of land commanded. Total deliveries to the region average about 1,400,000 ML/yr. There are some 1,100 licensed bores in the region with allocations in excess of 2,600,000 ML annually. Most of this (75%) is allocated against the Upper Shepparton Formation (shallow aquifer <20m). The lower Shepparton Formation (deeper aquifer 20-40m) has limited development across the region, accounting for 2% of licensed groundwater usage. Licensed extraction from the Calivil/Renmark aquifer (deep lead >100m) is the remaining 23% of total groundwater allocation (Goulburn-Murray Water, 1997b). Various surveys suggest that average groundwater irrigation usage is 20% to 50% of allocation but usage increases markedly in dry years. The reuse of surface drainage water is significant, totalling about 77,500 ML/yr or 6.5% of the surface water allocation. This occurs in about 52% of the area with groundwater extraction (Personal Communication K. Sampson, Institute of Sustainable Agriculture, Tatura).

The quality of surface irrigation supply water is very good, in the order of 0.05-0.13 dS/m, as it originates from the alpine areas of eastern Victoria. The groundwater quality is not that good or highly variable, 0.8 dS/m being typical of the best quality, generally being around 2 dS/m, but ranging to an excess of 15 dS/m. The quality of groundwater requires mixing with the fresher surface water before use. Generally on-farm use of groundwater is restricted to groundwater with salinities less than 3.5 dS/m. Groundwater, more saline than this, is only pumped for salinity control and is disposed of into major surface irrigation supply channels or directed to surface drains which flow to the river system.

Coleambally Irrigation Area

The Coleambally Irrigation Area (CIA) is a relatively small irrigation area. Farming is dominated by rice production. Other irrigated enterprises in the CIA are rice, sheep/annual pastures, winter crops (mainly wheat), soybeans and some horticulture (grapes, fruit, and potatoes).

In 1996, with average rainfall conditions, 27,000 ha or 34% of the area was underlain by shallow watertables. Shallow watertables are concentrated in the central and southern part of the CIA, the northern part does not seem to be affected at this stage. From hydrological modelling results (Van der Lely, 1994) it is found that the area with watertables within two metres below the surface will increase from about 27,000 ha in 1993, to about 60,000 ha by the year 2023. Especially the southern and central part of the CIA part will be affected.

Deep groundwater pumping lowers the pressure in the deep aquifer promoting vertical leakage from the shallow aquifer. The main Coleambally Irrigation bore pumping about 3,000ML/year induced a lowering of the groundwater level by 20-40 cm over a radius of several kilometres (Lawson and Van der Lely, 1992). Therefore, deep groundwater pumping is seen by Coleambally Irrigation Co-Op as a measure to combat salinity problems. However, studies by Prasad et al. (2001) show that deep pumping has to be carefully controlled to prevent salinisation of the aquifer. Salinisation will occur if deep pumping induces excessive movement of the saline water in the upper aquifers downward.

Water allocation within the CIA averages 6.7 ML/ha. The total surface water allocation for the CIA amounts to 480,000 ML/yr. Annual consumption ranges between 380,000 ML/yr and 600,000 ML/yr. There are 23 bore licences for privately owned and operated pumps by the landholders in the CIA. Coleambally Irrigation Co-Op operates one deep bore and mixes water from this bore with surface water in the supply channel. During 1997/98, 2,800 ML of water was pumped from the Coleambally deep bore and sold to irrigators in the CIA. The private pumpers within the CIA pumped a total of 45,698 ML. This is about 10% of the surface water allocation.

Irrigation water diverted to the CIA is considered to be of uniform high quality of 0.15 dS/m (Coleambally Land and Water Management Plan 1996 Draft). Salinity of the shallow groundwater ranges from 1dS/m to >20 dS/m. Salinity of deep groundwater increases from 0.5 dS/m in the northern part of the CIA to around 1.0 dS/m in the southern area.

Burdekin Irrigation Region

The Lower Burdekin is a large irrigation area dominated by sugarcane production. Salinity problems occur on the coastal margins due to seawater intrusion and on the border areas adjacent to the bedrock because of salt inflow from the bedrock.

In 1986, the Burdekin Falls Dam was built, allowing the development of the Burdekin River Irrigation Area (BRIA). In the BRIA there is potential for the development of high watertables and salinity problems. To prevent this situation, groundwater pumping is promoted by allocating groundwater volumes equal to average deep drainage losses, i.e. 1ML/ha/yr.

Water use in the Lower Burdekin is given in Table 2. Groundwater use in the delta is not metered and therefore not known.

Table 2 Water use in the different parts of the Burdekin region

	BRIA		NBWB		SBWB	
	(ML/yr)	(ML/ha)	(ML/yr)	(ML/ha)	(ML/yr)	(ML/ha)
Surface water	200,512	6	60,841	3	38,124	3
Groundwater	20,000	1	Not measured / unknown		Not measured / unknown	
Total	220,512	7	105,570	5	67,432	5

The North Burdekin Water Board diverted 105,570 ML from the river in 1997/1998 of which 60,841 ML were directly used as surface water (NBWB, 1998). Within the Northern delta, there are areas where only groundwater is used because the farmers do not have access to surface water. There are also areas where only surface water is used because there is no access to groundwater or because the groundwater is of poor quality.

In the southern delta, 67,432 ML of water was pumped from the river in 1997-98 of which 38,124 ML was used directly by the farmers. The remaining went to groundwater replenishment via pit recharge and in channel intrusion (SBWB, 1998a). In the southern delta, all land has sufficient groundwater supply and no land solely depends on surface water.

In practice, artificial recharge takes place from May to July and surface water is used directly by the farmers from August to February.

Surface water quality is low in salinity and high in alkalinity. This sometimes leads to crust formation and reduced infiltration. Mixing with more saline groundwater increases the infiltration characteristics. Groundwater quality in most areas is good with salinities generally lower than 1.0 dS/m. Higher salinities occur on the coastal margins and adjacent to the bedrock (more than 3.0 dS/cm) (Sinclair Knight Merz, 1997).

Watertable levels in the delta vary considerably with the dominant influence being climate. The peaks associated with floods and other major recharge events tend to fall away reasonably quickly (within a year), suggesting a higher rate of discharge to the sea at these times, and/or the movement of groundwater to deeper aquifers (Sinclair Knight Merz, 1997).

Examination of the salinity of bores over time indicate a trend to marginally increasing salinity of water through the period 1974 to 1987, followed by a sharp reduction in salinity relating to the flood of 1991. It appears that salinity levels increase during dry seasons but there is a considerable diluting and flushing effect from major flood events, reducing salinity (Sinclair Knight Merz, 1997). Maximum salinity levels in the bores further away from the river have not increased over time, although reductions in salinity have not reached the lowest recorded levels, suggesting that there may be an overall increasing level of salt input (Sinclair Knight Merz, 1997).

The history of seawater intrusion in the delta is not well known. The extent of seawater intrusion in 1996 suggests that the toe of the seawater wedge is being actively moved inland. In the northern delta the use of surface water for irrigation pushes the salt-water wedge to areas that had no salinity problems before (Personal communication J. Tait, James Cook University, Freshwater Research Center).

Institutions

Introduction

In Australia water resources management normally falls entirely within the jurisdiction of the States with no Federal government involvement. The Federal government of Australia does not have power to intervene in natural resource management issues unless they affect international obligations. The management of waters and rivers that are shared between states are usually covered under identical legislation enacted in the two states sharing the resource. The SIR and CIA are located within the Murray Darling Basin and are, therefore, also influenced by the policies of the Murray Darling Basin Commission, which is a multistate, plus Federal government organisation.

Shepparton Irrigation Region

There are many and varied organisations that have jurisdiction or influence in the allocation and use of water resources in the SIR. These organisations range from local community groups to the water provider to the Catchment Management Authority to State government. Also, since the SIR is within the Murray Darling Basin it is influenced by the policies of the Murray Darling Basin Commission, Figure 2. The main controlling bodies in the SIR are the Catchment Management Authorities and Goulburn Murray Water.

Figure 2. Schematic representation of the institutional arrangements in the SIR.

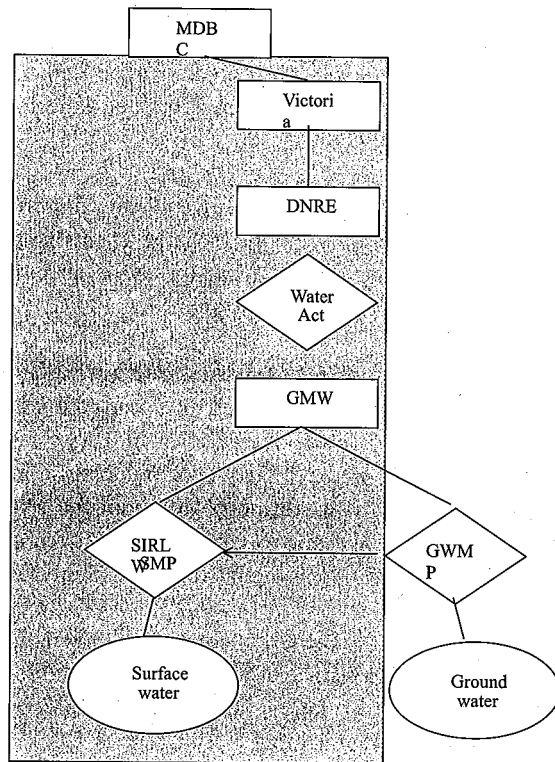

The Shepparton Irrigation Region is located in the areas of two Catchment Management Authorities, the Goulburn Broken Catchment Management Authority and the North Central Catchment Management Authority. The Implementation Committees of the Catchment Management

Authorities tackle the catchment issues identified in the Regional Catchment Strategies of the Catchment Management Authorities. The Implementation Committees act as a link between the board and the people of the catchment ensuring natural resource management reflects the views and concerns of the community. The Irrigation Committee is the Implementation Committee of both the North Central and the Goulburn Broken Catchment Management Authority for the Shepparton Irrigation Region; as it is the key institutional body in the region. The Irrigation Committee is responsible for the implementation of the SIRLWMSMP but has delegated the responsibility for most of the on-ground implementation to Goulburn Murray Water, the Rural Water Authority in the area. During the implementation of the SIRLWSMP, Goulburn Murray Water identified the need for a groundwater management plan to compliment the SIRLWSMP, and as such, is also responsible for administering and enforcing the groundwater management plan.

Goulburn-Murray Water is responsible for the management of the major water systems within its boundaries, provision of bulk supplies to (Non-Metropolitan) Urban and Rural Water Authorities and the delivery of irrigation water, domestic and stock supplies and drainage services and has been delegated responsibility by the Catchment Management Authority for most of the on-ground implementation of the SIRLWSMP. During the implementation of the SIRLWSMP Goulburn Murray Water identified the need for a groundwater management plan to compliment the SIRLWSMP, and as such, is also responsible for administering and enforcing the groundwater management plan.

The local governments realising the long-term economic threat of salinity to the region have formed a regional body, Municipalities Against Salinity in Northern Victoria (MASNV), and appointed a Municipal Salinity Liaison Officer to co-ordinate local government participation in the SIRLWSMP. The municipalities have developed uniform planning regulations for the implementation of drainage works under the SIRLWSMP. Furthermore, the local governments pay 17% of the annual costs of public salinity works constructed under the plan and have used provisions of the Local Government Act to support community salinity control projects (surface and sub-surface drainage) (Sampson, 1996).

Coleambally Irrigation Area

There are varied organisations that have jurisdiction or influence in the allocation and use of water resources in the CIA. These organisations range from local community groups to the water provider to the Catchment Management Committee to State government. Also, since the CIA is within the Murray Darling Basin, it is influenced by the policies of the Murray Darling Basin Commission. The main controlling bodies in the CIA are Coleambally Irrigation, an independent company that controls the allocation of surface water and the implementation of the Land and Water Management Plan and the Department of Land and Water Conservation (A State department that controls groundwater allocation), Figure 3.

Coleambally Irrigation (CI) was formed on 1st July 1997 under the Irrigation Corporations Act, 1994. The NSW Government Ministers for Treasury and for Regional Development and Rural Affairs are shareholders of Coleambally Irrigation. CI is responsible for supplying water to farms in the CIA. CI is also the single entity to implement the Coleambally L&WMP. CI is, therefore, responsible for both the commercial and environmental aspects of irrigated land use.

Figure 3: Schematic representation of the institutional arrangements in the CIA.

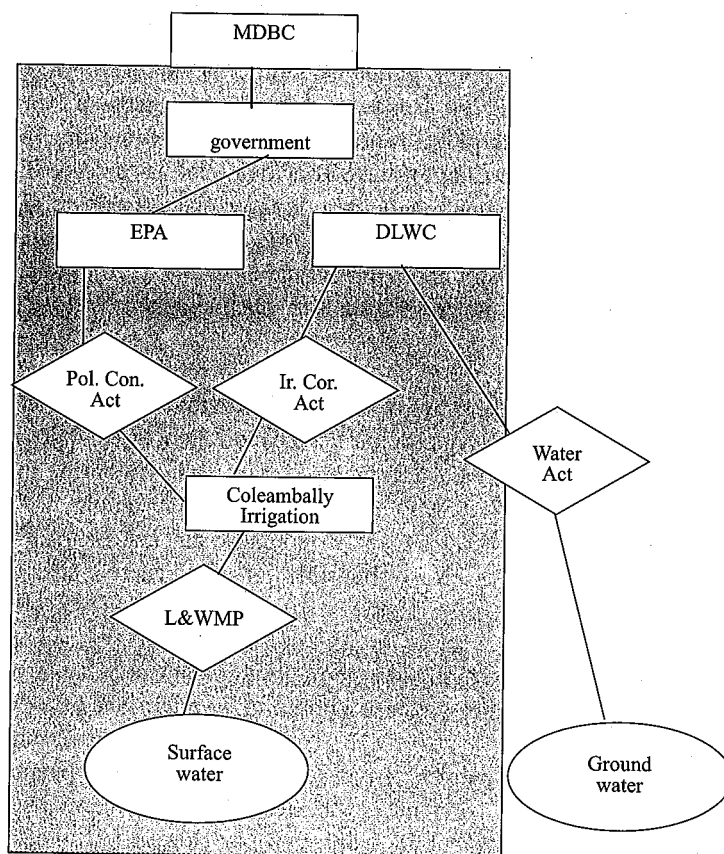

Burdekin Irrigation Region

The main controlling body in the Burdekin irrigation region is the Department of Natural Resources as this department controls both the water boards and SWP. The most important water allocation bodies are the North Burdekin Water Board, the South Burdekin Water Board and State Water Projects. SWP is the most important water provider as SWP delivers water to the farmers in the BRIA and the water boards, Figure 4.

State Water Projects was gazetted as a business activity of the Department of Natural Resources under the Queensland Competition Authority Act and operates in accordance with Treasury guidelines. State Water Projects is responsible for the management of state owned water infrastructure.

The North Burdekin Water Board and South Burdekin Water Board are structured under the provisions of the Water Resources Act. The Boards were constituted as underground replenishment Boards. The initial concept was to supplement the aquifer by diverting natural river flows into flood overflow channels in the delta. Artificial recharge was affected by natural percolation through the bed and banks of these natural watercourses in addition to intake through artificially constructed soakage pits. Today, artificial recharge and natural percolation still play an important but somewhat diminished role in the mode of operation, as the emphasis has shifted from pure recharge to aquifer management via conservation.

Figure 4: Schematic representation of the institutional arrangements in the Burdekin Region.

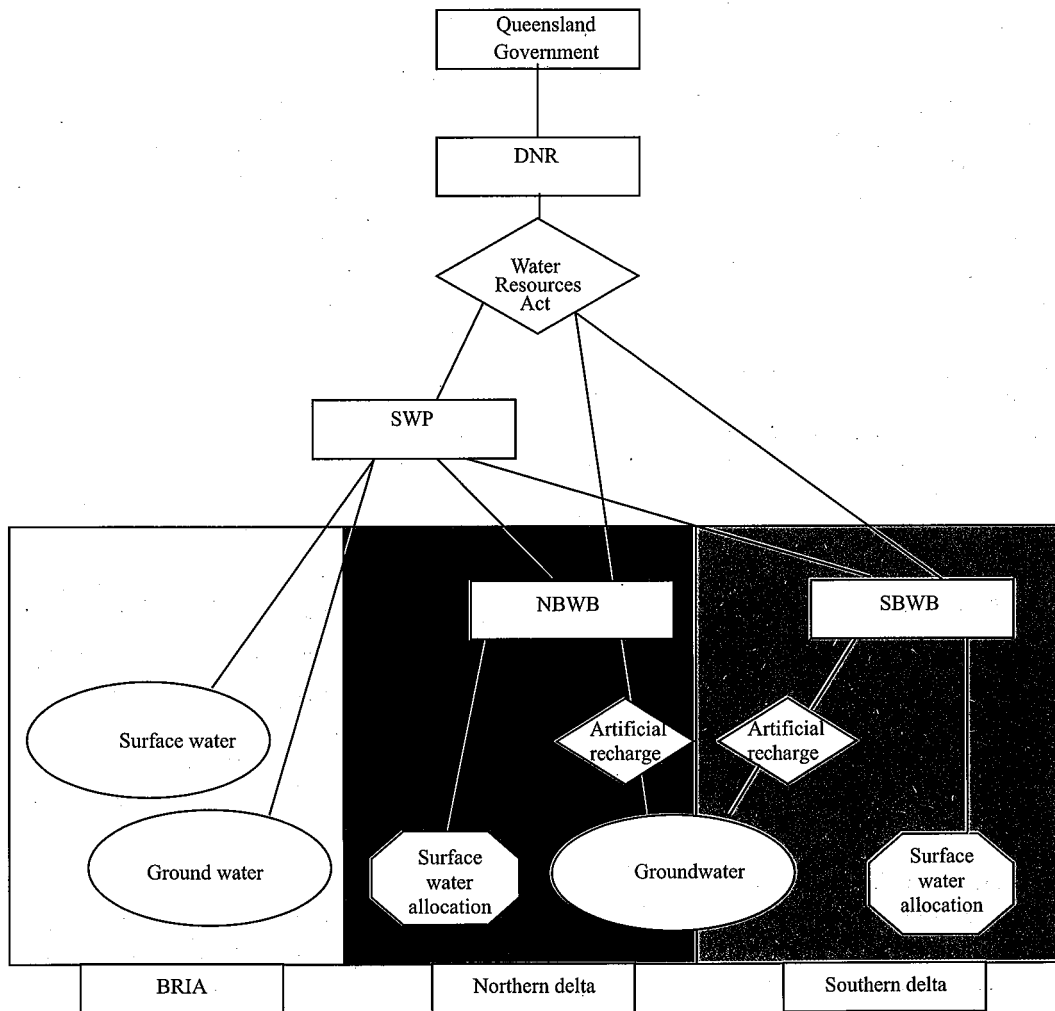

This is achieved by encouraging growers to take surface water directly from the Board's distribution system (NBWB, 1998). The water boards hold an allocation from SWP and decide to either use this water for artificial recharge or to supply it directly to farmers. The water boards have to report annually to the Minister (Department of Natural Resources).

There is no Catchment Management Authority or Committee that provides integration of the irrigation region with the upper catchment or the integration of water management with other environmental issues.

Plans and Policies

Shepparton Irrigation Region

In the SIR there are two key policy instruments, the SIR Land and Water Salinity Management Plan (SIRLWSMP) and the Groundwater Supply Protection Management Plan (GSPMP).

The SIRLWSMP was initiated in late 1980s due to community and governmental concern about increasing salinisation in the area. The local community, especially farmers have been intimately involved in the development of the SIRLWSMP from the outset.

The Groundwater Supply Protection Management Plan (GSPMP) is a more recent initiative. Goulburn Murray Water initiated the GSPMP after considering their role in implementing the SIRLWSMP. They found that the management of groundwater allocation and pumping in the region was inadequate in terms of meeting the SIRLWSMP objectives. They have used the GSPMP to bring groundwater resource management under their control and to align it with the SIRLWSMP objectives. Another development are the Regional Catchment Strategies, which are catchment wide strategies that have adopted the SIRLWSMP as their Irrigation Program.

The policies of the Murray Darling Basin Commission have a large influence upon the policy directions and socio-economic conditions of the region. New initiatives including "The Cap", which put a limit on surface water use and water market reform have the potential to fundamentally change the resource allocation system and the price for water. They can create a period of rapid change and structural adjustment. These factors may have a great impact upon the socio-economic position and viability of the region.

The Shepparton Irrigation Region Land and Water Salinity Management Plan

Victoria's Salinity Program has been a major ongoing initiative of the community and the State Government since 1986. In 1988 "Salt action: Joint Action", a state strategy for managing land and water salinity in Victoria was released. The principal long-term goal of the program was: " *...to manage the salinity of the land and water resources throughout Victoria in order to maintain, and where feasible, improve the social well being of the communities and the environmental quality and productive capacity of the regions*".

The strategy divided the state into nine catchment-based salinity control regions. It also defined a need for 20 sub-regional salinity management plans or regional salinity strategies covering those irrigation and dryland regions affected by salinity or contributing to salinity damage in Victoria or downstream within the Murray Darling Basin. The SIRLWSMP was one of the first sub-regional plans endorsed by the Victorian government.

The goal of the SIRLWSMP is: "To manage the salinity of land and water resources and the quality of water in the Shepparton Irrigation Region in order to maintain, and where feasible, improve social well-being, environmental quality and productive capacity of the Region". The original SIRLWSMP is now an integral part of the Regional Catchment Strategies of the North Central and Goulburn Broken Catchment Management Authorities. The Irrigation Committee of the Catchment Management Authorities is charged with the implementation of the SIRLWSMP (SPACC, 1989). Goulburn Murray Water has been delegated the responsibility for most of the on-ground implementation.

The farm program of the SIRLWSMP has the goal of reducing groundwater accessions, soil salinisation and waterlogging on farms. The main components of this program include whole farm planning, irrigation re-development, improved water management, environmental enhancement, tree growing and improved productivity.

The sub-surface drainage program has the goal of, where possible and justified, protecting and reclaiming the region's land and water resources from salinisation through management of the region's groundwater. Sub-surface drainage will be provided by activities of individual farmers under the farm program and by community activity in priority project areas where pump operation will be managed to provide seasonal watertable control in conjunction with regulated disposal of salt both within the region and to the river Murray. The main components of this program are installation of groundwater pumps, tile drains and low capacity pumps, and disposal. The groundwater pumps can be either private if the groundwater salinity is less than 3.5 dS/m or public when the groundwater salinity is more than 3.5 dS/m. Private groundwater bores are used for irrigation after dilution with surface water to a salinity of 0.8 dS/m. Irrigation water quality of 0.8 dS/m has been adopted as the critical level, as research in the area has shown that it does not cause any productivity loss for pasture (Heuperman, 1988). This program is one of the most readily adopted parts of the SIRLWSMP, especially the private pumps. This has been due to the great support for this aspect of the plan, including a previous waiving of all statutory charges on groundwater use by the Minister and the attraction of a supplementary water supply to farmers. The public pumps have not been as readily adopted, as they cannot be used for water supply. However, in recent times the demand for public pumps has increased as the community becomes more aware of and educated about the threat of salinity. At present the demand for both private and public pumps outstrips the funds available and hydrological investigation capacity of Goulburn Murray Water.

During both the preparation of the SIRLWSMP and the subsequently implementation, particular emphasis has been placed on ensuring broad community input into its development and on-going refinement, and ensuring continued community support for its implementation. This has been a major strength of the Plan. The key to success of the plan is to include the community through a framework of community education and supports.

Coleambally Irrigation Area

In the CIA the key policy instrument is the Land and Water Management Plan (L&WMP). The Coleambally community prepared and endorsed a Draft L&WMP in March 1994. The 'Final Draft' was issued in March 1996 (Coleambally Irrigation, 1999). The L&WMP addresses the increasing salinity problems in the area and is also used by Coleambally Irrigation to satisfy the EPA Pollution Control License with respect to the level of nutrients and pesticides in the drainage system.

A more recent development is the Murrumbidgee Catchment Action Program (MCAP), which is a catchment wide strategy. The MCAP supports L&WMPs and their priorities but does not incorporate it. The actions proposed by the MCAP apply to all irrigation enterprises and do not replace the detailed actions of the LWMPs.

At state level the NSW water reform package has been developed and will influence the allocation and price of water. It also provides regulations for environmental flows. The policies of the Murray Darling Basin Commission have a large influence upon the policy directions and socio-economic conditions of the region. New initiatives have the potential to fundamentally change the resource allocation system; the price and availability of water can create a period of rapid change and structural adjustment and may have a great impact upon the socio-economic position of the region.

The Coleambally Land and Water Management Plan

The objective of the Coleambally Land and Water Management Plan is stated as follows: "To ensure the Coleambally Irrigation Area remains a sustainable irrigation area and will address specifically the control of watertables and salinity, downstream effects of the Coleambally Irrigation Area and future research needs for the area, and to ensure that the final plan is acceptable to the Coleambally Irrigation Area landholders, townspeople of Coleambally, residents of those areas serviced by water from the Coleambally Irrigation Area and any government instrumentalities associated with the Coleambally Irrigation Area" (Coleambally Irrigation, 1999).

To achieve the objectives, the L&WMP has been organised into two major implementation components: net recharge management and drainage water quality control (Coleambally Irrigation, 1999). These two components are linked and facilitated by an Education component.

The Community Environmental Committee is responsible for assessing the progress of the various projects being conducted and the overall progress of implementation of the L&WMP. It is their role to maintain community ownership of the plan and to identify priority issues and the needs of the community with regard to implementation of the plan.

A reduction in accessions of 29 GL/yr is believed to be required to achieve sustainability. Consequently, a 29 GL/yr reduction in accessions was adopted as a tentative target for integration of the options. Furthermore, it was agreed that overall areas affected by soil salinity should not exceed 15% of the area over the longer term and has to be achieved in all of the four main parts of Coleambally – North, Central, South and West.

The key to farmer adoptions of most of the on-farm proposals is incentive schemes. The incentive schemes aim to encourage a community mind-set that acknowledges the importance of farm planning (especially in respect of drainage) and farmer education (particular in the environmental implications of farm management). From a conjunctive water use perspective, deep bore pumping and shallow groundwater pumping is important. It is expected that up to 75% of the deep bore volume can be sold by auction to landholders outside the CIA (Coleambally Land and Water Management Plan 1996 Draft). Shallow groundwater pumping is not required immediately but increases to a maximum by year 30 of the plan. It is supposed to take place in the southern parts of the Coleambally Irrigation Area only.

Burdekin Irrigation Region

There are no integrated policies for the whole Burdekin Irrigation Region and there are no Land and Water Management Plans for the region. The allocation policies of the water boards and SWP are, therefore, the most important policies.

Allocation Rules and Policies

Shepparton Irrigation Region

Under the Water Act the Department of Natural Resources and the Environment (DNRE) gives a bulk water entitlement for both surface water and groundwater to Goulburn Murray Water, which redistributes this water to the farmers who hold an individual allocation. New allocations can only be obtained through purchases from other farmers.

Coleambally

Surface water is allocated by Coleambally Irrigation, which holds a bulk water entitlement from DLWC. An allocation scheme has been based on historical usage rather than seasonal crop usage provides a distribution of water resources to all users.

The Department of Land and Water Conservation allocates groundwater. Groundwater allocations are based on the property area and the amount of surface water allocated to that property; the higher the surface water allocation, the lower the groundwater allocation (Personal communication S. Lawson, DLWC). At this time there is a statewide moratorium on new groundwater developments. Existing entitlement holders that do not use their entitlement (sleepers) can get a new license to increase pump capacity and use the entitlement. Total groundwater use can, therefore, still increase.

Burdekin

Water licences in the BRIA are issued by DNR under the Water Resources Act but are completely based on recommendations and approval of SWP. The allocation procedure is based on a maximum allocation of 10 ML/ha. The granting of this allocation is determined by the yield of the system. The groundwater system already has its natural sustainable yield fully allocated and the only extra groundwater that is granted is 1 ML for every 8 ML of surface water allocated. This is done to minimise the effects of deep drainage losses and to encourage the use of groundwater to control watertables but it is not compulsory to use this 1 ML of groundwater. The 1 ML of recharge for every 8 ML of surface water used is an average based on the soils in the BRIA.

Anything in excess of the 8+1 ML/ha up to a maximum of 10 ML/ha of surface water has to take into account environmental constraints, usage patterns, soils, and depth to groundwater, groundwater salinity, and watertable trends. The surface water system has constraints due to design capabilities i.e. the design flow rate of a channel may restrict the delivery ability. State Water Projects does not allocate above the designed maximum flow rate for any system.

In the delta the water boards hold a surface water allocation from the Burdekin Falls Dam. This water is delivered to the water boards by SWP. The water boards decide either to use it for artificial recharge or to distribute it directly to the farmers.

All growers close to surface water supply in the delta are encouraged to use surface water. The use of surface water is encouraged as a management tool to preserve groundwater for those growers who do not have access to surface water. There are no restrictions on the maximum use of surface water by licensed users. However, usage is modified to some extent by the implementation of an excess usage charge based on the prescribed allocation for that year. This allocation is subject to board decision, depending on prevailing weather conditions influencing the availability of supply. To date this pricing index has varied from 8 to 10 ML/ha in the northern delta and 4 to 6 ML/ha in the southern delta. A grower can use surface water as required but always has to roster in advance in the southern delta and in periods when demand exceeds supply in the northern delta. Farmers in the southern delta are only allowed to pump at a maximum flow rate of 90 L/sec for a maximum of 5 days over 50 ha and can do this twice a month with a minimum 10-day gap between the two irrigation periods (SBWB, 1999).

The situation in the CIA is different. The regional authority has control over surface water while the State authorities control groundwater. Differences in opinion and poor co-ordination between the two do occur. This is limiting effective implementation of conjunctive water management and makes implementation of the L&WMP by the regional authority dependent on the State authorities to allocate groundwater for salinity control purposes. The grey area indicates the area of influence of the MBDC through the Cap. In the BRIA, surface water and groundwater are managed by SWP. This enables effective implementation of conjunctive management. Furthermore, conjunctive water use is promoted by allocating surface and groundwater conjunctively.

The water boards hold an allocation on behalf of the farmers in the delta. The water boards manage surface water and groundwater in the delta but the water boards depend on the SWP for surface water. The boards only redistribute the water that they get from their allocation from SWP. Furthermore, the two water boards manage the same aquifer; this makes efficient and effective management difficult. Poor co-ordination in the Burdekin takes place; for example, water from the dam is not always released from the top so that the water boards can use low turbidity water for artificial recharge. DNR prefers turbid water as this reduces grass and weed growth in the channels.

Other control problems in the delta are related to the allocation system. The boards have difficulties in managing the aquifers because they do not know how much groundwater is used, as there are no volumetric allocations and the bores are not metered. The SBWB measures watertables themselves and can adjust recharge consequently. The NBWB is completely dependent on DNR for groundwater data. Although these difficulties exist, the water boards have been effective in managing the watertables and reducing seawater intrusion. This is shown by increased sugarcane production since the late 1960s when the water boards were established (38).

Water allocation

It is evident that only in the SIR do the water allocation principles provide an incentive to increase water use efficiency, as water use above allocation is not allowed and all surface water is paid through the usage fee. Water savings in the CIA are not promoted as much, as a large part of the total costs is a fixed charge. Water use above allocation in the BRIA is allowed but is discouraged by the high excess rates. High losses to the aquifer are not sustainable as they lead to watertable rises, increasing the salinity risks and leaching of agricultural chemicals. Higher losses increase the need for groundwater pumping and conjunctive water use.

The allocation system in the Burdekin delta promotes water losses. This is in agreement with the board policies of recharging the aquifer but leads to off-site impacts as chemicals are leached to the aquifer as well and eventually end up in the wetlands or near shore areas causing environmental degradation. It is, therefore, recommended that the boards change their policy and no longer promote losses. Without jeopardising watertable control, this can only take place when more surface water is used.

Water trading

Water trading provides an incentive to increase water use efficiency and thus reduces accessions to the aquifer and groundwater rise and salinity problems as unused water has an economic value. It also prevents leakage of agricultural chemicals. Water trading takes place on a large scale in the SIR and CIA only. Because the Burdekin Falls Dam is not fully allocated yet, allocations for new irrigation areas can be obtained from SWP and do not have to be purchased from other farmers. It is

expected that water trading will increase when the dam is fully allocated. Under the present water allocation structure of the water boards, water trading is not possible.

Integration

In the SIR there is good integration between water management and other environmental management issues and between the irrigation area and the rest of the catchment as the land and water management plan is an integral part of the Catchment Strategy. In the CIA there is some integration between the CIA and the rest of the catchment and between water management and environmental management. However, this is only a weak link as the L&WMP is not an integral part of the Catchment Action Plan and the link between CI and the MCMC is informal. In the Burdekin there is no integration between environmental management and water management; between the three management areas; and the irrigation region and the upper catchment. Furthermore, there is no integration between SWP, the NBWB and the SBWB. Integration would prevent actions in one area have negative consequences in another area or environmental compartment and thus promotes more effective and efficient policies.

Community involvement

In all three areas, there is some form of communication between the farmers and the water suppliers and managers. In the SIR and the CIA, the community is involved in salinity management through the Land and Water Management Plans. Only in the SIR is the whole community (also the non-farmers) involved and contributing financially to salinity management.

Enforcement

In all three areas conjunctive water use is voluntary. Some enforcement is needed, as a minimum volume of groundwater has to be pumped for salinity control in dry years when additional water is not needed. In the BRIA groundwater pumping is promoted by not charging for it. This promotes conjunctive water use.

In general, farmers are willing to pump groundwater as this increases their total water allocation and increases production. The high investments needed for a groundwater pump can keep farmers from installing a pump. Only in the SIR, are incentives available for pumping groundwater.

In the CIA, CI does deep groundwater pumping under the L&WMP. This reduced the task to control groundwater pumping, as only one authority instead of all farmers has to be controlled.

Long-term Sustainability Issues

Watertable control

In the SIR, CIA, and BRIA, groundwater pumping provides watertable control. Groundwater pumping in the Burdekin delta and some places in the BRIA leads to seawater intrusion. Deep groundwater pumping in the CIA leads to lowering pressures and groundwater mining as the aquifer is already over allocated.

Aquifer salinisation

Although conjunctive water use is implemented to prevent or reduce salinity problems it can also exacerbate them. In the SIR and CIA, conjunctive water use leads to aquifer and soil salinisation but

the problems in the CIA are smaller as the aquifer is larger and groundwater is less saline than in the SIR. For the major part of the Burdekin conjunctive use of groundwater and surface water does not lead to aquifer salinisation as dilution during floods and leakage to the sea takes place. When managed in a proper way conjunctive water use does not lead to seawater intrusion. Aquifer salinisation related to conjunctive water use does occur on the margins close to the bedrock and on the coastal margins where surface water pushes the seawater wedge to other areas. Conjunctive water use does not provide a solution for salinity control on the coastal margins and the areas close to the bedrock in the Burdekin. Irrigation in these areas should, therefore, be stopped. On the coastal margins, use of groundwater leads to seawater intrusion, surface water use pushes the salt-water wedge to other areas and conjunctive water use is likely to lead to both effects. From modelling it is known that irrigation on the margins adjacent to the bedrock can not be sustainable as groundwater use leads to salinisation, surface water use leads to the movement of salts into the board area and conjunctive water use leads to both effects.

Downstream salinity effects

Salt disposal is a problem for the SIR and CIA. Discharge of salt in the river Murray leads to downstream problems and is restricted by the MDBC Salinity and Drainage Strategy. Reuse of groundwater reduces the need for salt disposal and thus provides more protection for the downstream users than groundwater pumping without reuse. The Burdekin is located close to the sea and salts can, therefore, be discharged.

Acceptance and equity issues

Conjunctive water use leads to an increased production in all three areas because of the increased supply of water and salinity benefits. This is the most important reason why farmers accept (and implement) conjunctive water use.

Community awareness programs have increased the awareness and knowledge of the environmental problems faced by the people. A high level of awareness together with the high level of community involvement and participation in the development and implementation of the land and water management plans makes the people in the SIR and CIA feel that it is their plan and they accept it.

As the land and water management plans are developed in close consultation with the community, they are developed in such a way that the community can accept and implement them. For example, groundwater pumping up to 3 ML/ha in the SIR is allowed while only 1 ML/ha is needed for salinity control. A trade off between environmental protection and community acceptance has thus been made.

Plan managers accept that some land will go out of production. In the SIR it is accepted that 10-20% of the area will be difficult to manage. In the CIA it is accepted that 15% of the land will be affected by soil salinity. This will not only lead to environmental degradation but also to production decline for the farmers in these areas. The land and water management plan thus excludes some areas.

Groundwater pumping in the SIR and CIA leads to an increase in salinity of the river Murray and thus imposes a cost on downstream users. The MDBC Salinity and Drainage Strategy address this issue by setting a limit on salt disposal.

Table 3: Comparison and summary of conjunctive water use in the three regions.

	SIR	CIA	BRIA	Burdekin Delta
Type of conjunctive water use				
Surface water	Yes	Yes	Yes	Yes
Groundwater	Yes -shallow	Yes - deep	Yes	Yes
Drainage water reuse	Yes	Yes	Yes	No
Objective of groundwater use	Salinity control and supply	Salinity control and supply	Watertable control and supply	Irrigation supply and watertable control
Water use				
Average groundwater use (ML/ha/yr)	2.16	0.6	1	Unknown-
Average surface water use (ML/ha/yr)	3.6	6.7	8	Unknown
Crop water requirement for main crop (ML/ha/yr)	10 - perennial pasture 7- horticulture	15 -rice	10 - sugar	10 - sugar
Average groundwater price (\$/ML)	20	0.60	0	10
Average surface water price (\$/ML)	21	15	36	15
Benefits of conjunctive water use				
Increased supply	Yes	Yes	Yes	Yes
Increased flexibility	Yes	Yes	Yes	Yes
Reduced costs	Insignificant	Insignificant	Yes	Insignificant
Increased quality	Yes	Insignificant	Yes	Insignificant
Institutional issues				
State owns and controls both groundwater and surface water	Yes	Yes	Yes	Yes
Groundwater and surface water same management institute	Yes	No	Yes	Yes/No(*1)
Integration with surrounding area	Good	Average	Poor	Poor
Integration with other environmental issues	Good	Average	Poor	Poor
Community involvement in environmental and water management	Good	Average	Poor	Poor
Allocation				
Metered groundwater	Yes	Yes	Yes	No
Metered surface water	Yes	Yes	Yes	Yes
Specified maximum allocation groundwater	Yes	Yes	Yes	No
Specified maximum allocation surface water	Yes	Yes	Yes	No
Excess usage of groundwater allowed	No	Yes	Yes	No
Excess usage of surface water allowed	No	Yes	Yes	No
Fixed fee groundwater	Yes	Yes	Yes	Yes(*2)
Usage fee groundwater	Yes	Yes	No	No(*2)
Fixed fee surface water	Yes	Yes	No	No(*2)
Usage fee surface water	Yes	Yes	Yes	Yes for cane(*2)
Trading surface water	Yes	Yes	Yes	No(*2)
Allocation system promotes water savings	Good	Poor	Adequate	Very poor(*3)
Long term sustainability issues				
Aquifer salinisation	Large problem	Problem	Problem on margins (*4)	Problem on the margins (*4)
Salt export	Problem	Problem	No Problem	No Problem
Acceptance and equity issues				
Increased production and profitability	Yes	Yes	Yes	Yes
Accepted by the farmers	Yes	Yes	Yes	Yes
Some land lost due to salinity	Yes	Yes	No	No
Downstream increase in salinity	Problem	Problem	No Problem	No Problem

(*1) Water boards hold an allocation from SWP and are thus dependent on SWP

(*2) In theory small crop growers can choose to pay a usage fee but in practice they choose the area fee

(*3) In agreement with Board policy

(*4) Seawater intrusion is not an inherent problem related to conjunctive water use and can be avoided by proper management of the watertable.

CONCLUSIONS AND RECOMMENDATIONS FOR THE SEPARATE AREAS

Shepparton Irrigation Region

Water is allocated, controlled and managed by the same authority. This makes effective implementation of conjunctive water use possible. The management authority is also responsible for salinity management, thus being able to combine water management and environmental management. Through the integration of the SIRLWSMP in the Catchment Strategy, conjunctive water use for salinity control in the SIR is well integrated in general environmental management and with the upper catchment. As the community is very much involved in the management and salinity mitigation program as well, it can be said that the institutions for the implementation of conjunctive water use are working well and promote effective implementation.

Conjunctive water use is the only option for salinity management in the SIR but may not provide a long-term sustainable solution as it leads to an increase in aquifer salinity. It, therefore, only buys time. At this time there is no solution that provides enough protection and is economic at the same time. Buying time may suggest waiting until scientists find a solution. It is, therefore, recommended to provide as much protection as possible to minimise the rate of aquifer salinisation as far as possible by only pumping for salinity control, not for supply and to prevent groundwater from being used in an area that is smaller than the area of influence. This will then buy as much time as possible.

Coleambally Irrigation Area

Groundwater and surface water are allocated, controlled and managed by separate authorities. This limits the effectiveness of implementation of conjunctive water use. It is, therefore, recommended that DLWC shall give control over groundwater in the CIA to CIC by allocating a bulk groundwater entitlement to CI, as it is done for surface water. This will prevent groundwater pumping having adverse effects on other groundwater users and would allow CIC to manage conjunctive water use to provide salinity control. It is not recommended to increase the area to include primarily the whole aquifer and the bore pumpers outside the CIA because CIC is not a CMA but a water delivery corporation. Integration of the CIA with the catchment and the integration of water management with environmental management could be better. It is recommended to make the L&WMP part of the Catchment Action Plan. There is another option suggested to leave the responsibility for the implementation of the L&WMP with CIC as they have more contact with the community and have greater affinity with the area than the MCMC. The MCMC is concerned with the whole catchment while the CIA is only a small part of the Murrumbidgee catchment.

Conjunctive use of deep groundwater and surface water helps in achieving a water balance but leads to mining of groundwater as the aquifer is already over-allocated. It is, therefore, recommended to further reduce the accessions to the aquifer for watertable control and introduce shallow groundwater pumping for salt balance to reduce the volume of deep groundwater that has to be pumped. Charging only usage fees will provide an incentive in reaching the goal of reduced accessions. To make effective management and implementation of shallow groundwater pumping possible, it is recommended to give CIC the authority to manage shallow groundwater.

Burdekin River Irrigation Area

Water is allocated, controlled and managed by the same authority, SWP. This makes effective implementation of conjunctive water use possible. There is no integration of water management in the BRIA with the delta or the upper catchment. Furthermore, there is no integration of water management with other environmental issues. This leads, for example, to the deterioration of wetlands as the hydrology is changed and drainage water ends up in the wetlands. It is, therefore, recommended to integrate water management in the BRIA with environmental management in the whole catchment by developing a LWMP for the irrigation region and a Catchment Strategy for the Burdekin catchment. To be able to develop and implement the catchment management a Catchment Management Authority is needed.

It is recommended to cease the practice of farmers using more water than allocated to them or to increase the price of water above allocation so that it becomes unattractive. Furthermore, it is recommended that it becomes obligatory to pump 1 ML of groundwater for every 8 ML of surface water to ensure that farmers do pump in wet years when the additional supply is not needed and watertables do not rise.

Burdekin Delta

The water boards manage groundwater and surface water but as water is not allocated, the boards do not have the exact information about its use. This limits effective management. Furthermore, the two boards try to manage the same aquifer. There is no integration between the northern and southern delta; between the delta and the BRIA; between the delta and the rest of the catchment; and between water management and other environmental issues. It is, therefore, recommended to create one management body for the irrigation areas (see also below) and to create a Catchment Management Authority to promote the integration of water management with other environmental issues and the integration of the floodplain with the hinterland. It is recommended that a Land and Water Management Plan be developed for the Lower Burdekin. This should be the local implementation plan of the Catchment Strategy.

Some conjunctive water use is needed to increase the infiltration capacity and to prevent a crust formation caused by the high alkalinity and low salinity of the surface water. Installing a central bore in the area to mix surface water with some groundwater before it goes into the supply channels, would be a good way to control groundwater use and prevent over pumping. Conjunctive water use might also be needed on the less permeable soils. It is recommended to change to an allocation system with a fixed maximum and a usage fee to promote efficient use when only surface water is used.

It is recommended that only one authority manage the Lower Burdekin because three different authorities in one area lead to ineffective measures as they all deal with the same aquifer but have no control over the actions of others. It is also suggested that SWP manages the area and gives all farmers their own allocation for both surface and groundwater instead of a combined allocation to the water boards.

RECOMMENDATIONS REGARDING INSTITUTIONAL ARRANGEMENTS FOR CONJUNCTIVE WATER MANAGEMENT

A state needs to own and control all water within the state. The state, via a Natural Resources Agency should then redistribute water to the inhabitants by allocating bulk water entitlements for surface water and groundwater to a Local Water Management Authority (LWMA) like G-MW, CIC, or SWP. A Catchment Management Authority (CMA) needs to be responsible for the environment in the catchment. An Irrigation Committee (IC) of the CMA is required to ensure oversights of the environment in the irrigation area. An outline of the possible key institutions for improved conjunctive water management of surface water and groundwater is given in Figure 5.

The community should be involved in the development and review of the catchment management plan through a Catchment Community Panel (CCP) that is made up of catchment members who are elected by the inhabitants of their region and representatives of the peer groups (agriculture and environment). The environment would need to be represented on the Catchment Board, Catchment Community Panel and the Environmental Committee. The possible make up of these institutions is given in Table 4.

Table 4. Analysis of appointment to, and make up of key institutions in the ideal situation.

	Appointed by	Elected by	Reports to / responsible to	Role is communication to the public	Peer group representation	Peer group Lobby	Local*
Catchment Management Authority							
Board	Minister	-	Minister**	-	X	-	C
IC	CMA Board	-	CMA Board	X	X	-	R
CCP		Inhabitants	CMA Board	X	X	-	R
Local Water Management Authority							
Board	Minister	Water users	Minister	-	-	X	R
Water Users Committee	-	Water users	LWMA Board	X	-	-	R
Environmental Committee	Local government	Inhabitant	LWMA Board	X	X	X	R

*C = from the catchment, R = from the region

**The community nominates the board members of the CMAs for appointment by the minister.

The LWMA will divide the bulk entitlements it receives for both groundwater and surface water to the users in the area. To ensure alignment with state or national policies, the LWMA would be controlled by the government departments responsible for the management of natural resources and the environment.

The LWMA should be responsible for allocation and delivery of water and environmental management in the region. The authority, therefore, needs to be divided into two sections: Water Delivery and Environmental Management in order to minimise the possibility of conflict of interest. Half of the board members could be elected by the water users in the area and the other half could be appointed by the management of the LWMA or the responsible state department for their expertise in agriculture, environmental and resource management, financing, fisheries, etc. This ensures that local people who have affinity with the region manage the local authority and that enough expertise is available on the board as well. The board members would need to communicate

with the water users in the area through a water users committee whose members are elected by their peers. The board can communicate with the community on environmental issues by establishment of an environmental committee made up of community members, local government and environmental representatives.

Figure 5: Possible institutions for improved conjunctive water management

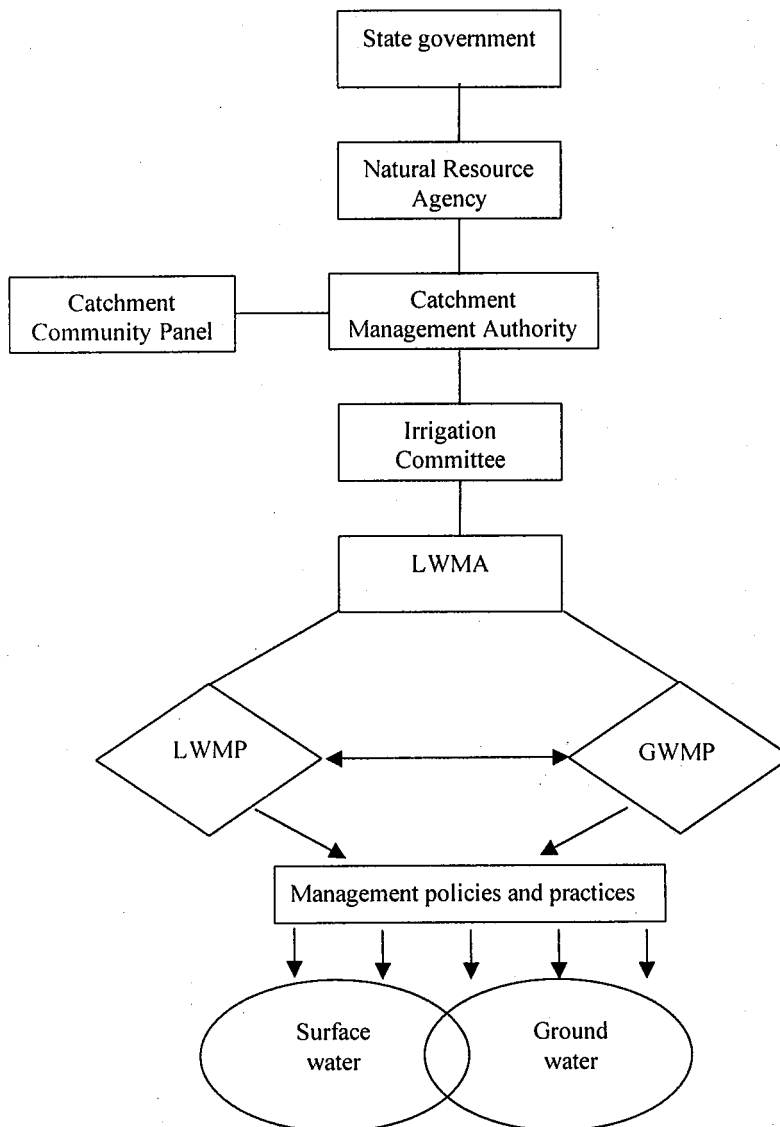

Allocations for surface water and groundwater need to be volumetric and must contain an absolute maximum. To promote conjunctive use, surface water and groundwater could be allocated conjunctively. Allocations also need to set a minimum usage for groundwater when pumped for salinity control. Water usage must be measured and paid for by the users. Water prices could be tried to provide incentive to save water but keeping the price for an average water user at the same level and thus enable him to invest in measures that improve water use efficiency.

Water trading of surface water within a river system needs to be encouraged as it provides an incentive to increase water use efficiency. However, a minimum volume should be kept within a certain area or on a farm to avoid steep rises in the delivery costs for other farmers. A central body (the State Natural Resource Management Department) needs to regulate water trading. Transfers would only be allowed after approval from the local water management authority to ensure compatibility with environmental management objectives and channel capacity.

Land and Water Management and Groundwater Management Plans (LWMP & GWMP) have been powerful tools in the past and are recommended to address the environmental problems related to land and water management in the region. The community needs to be involved and play a major role in the development and review of such plans. General community ownership of the plans must be ensured through the Environmental Committee of the LWMA. The LWMA will be responsible for the implementation of the plans. The farmers and the federal, state and local government who provide the funding subsidies will finance implementation of the plans. However, the whole community should contribute to the implementation through a general levy as everyone benefits from the implementation of the plan. This is on the basis that land and water management is not a problem facing farmers alone; it affects the whole community in one way or another.

Land and Water Management and Groundwater Management Plans are an integral part of the Catchment Strategy to ensure integration of the irrigation region within the whole catchment and integration of water management with environmental management. The Catchment Management Authority can pass responsibility for implementation of environmental programs in the irrigation area to the Irrigation Committee but keeps overall control on the implementation of the Catchment Strategy. The irrigation committee will delegate responsibility for on ground works of the plans to the LWMA. This provides better adjustment to the local or regional situation and increased community participation. This is especially important in large catchments where an irrigation area only forms a small part of the catchment and the catchment board members have less affinity with the irrigated region. A member of the LWMA should also be member of the catchment management board in order to provide better communication between the two. The Catchment Management Authority should be funded by state and federal government and by all inhabitants of the catchment through a catchment-tax. All inhabitants contribute because all inhabitants are beneficiaries. The landholders in the catchment could also pay a landholder-tax based on the size and value of the land, as they are the direct beneficiaries.

How these institutions sit within the greater picture of basin management and local government and how these should communicate is outlined in Figure 6.

Implementation of conjunctive water use should be mostly voluntary, based on farmer initiatives and incentive schemes to reduce the need for legislative enforcement. Extensive community education and awareness campaigns are required to make all farmers aware of the subsidies available and the benefits of conjunctive water use. Subsidies are only given to farmers with the whole farm plans to optimise expenditure. Enforcement, where necessary is dealt with using the licensing system, this specifies minimum and maximum water use. Non-compliance may result in a withdrawal of the license.

Figure 6. Required formal linkages between authorities and the community

Communication between the different authorities

- Formal direct link
- Indirect link through elections
- R Representation of agricultural and environmental groups
- L Lobby of agricultural and environmental groups

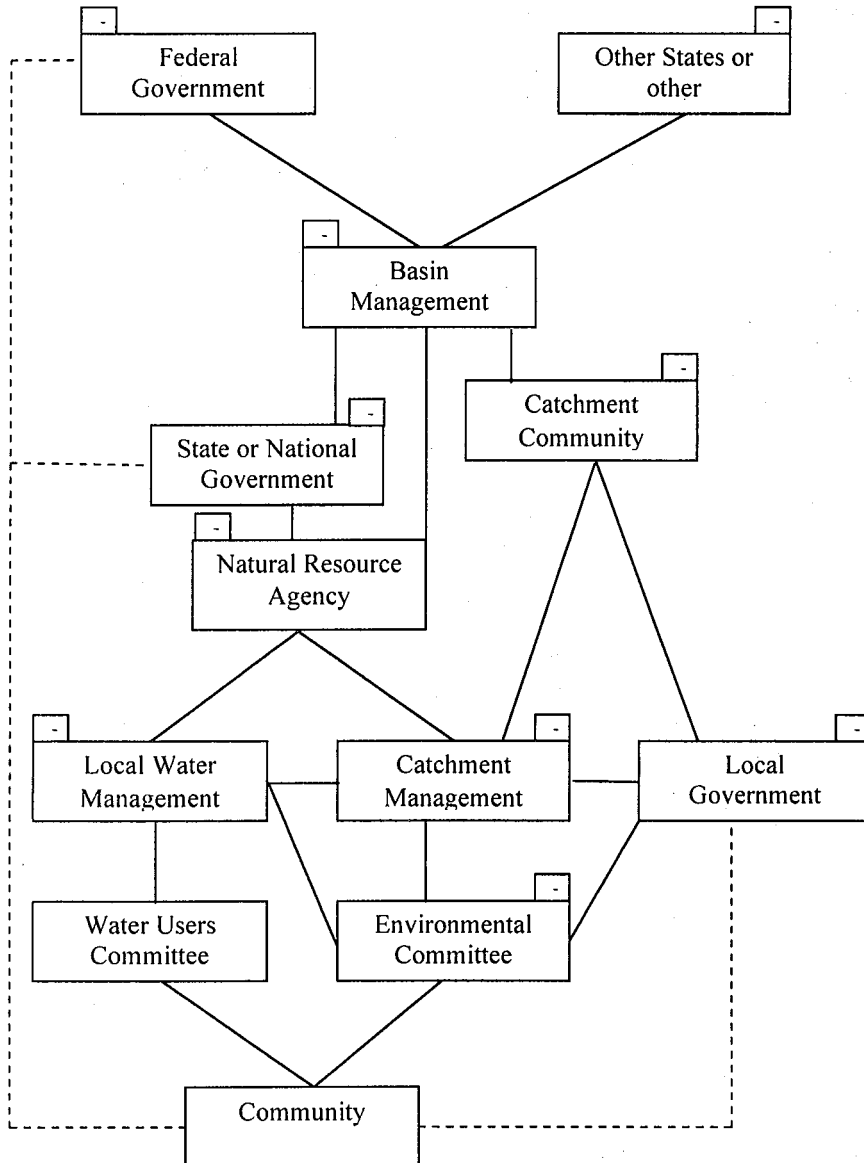

ACKNOWLEDGEMENTS

This research was jointly funded by CSIRO Land and Water, Griffith, Australia and the Australian Center for International Agricultural Research (ACIAR), Canberra.

REFERENCES

- Coleambally Irrigation (1999), annual environmental report 1998
- Doherty (1997) Processes affecting salinity in groundwater entering the South Burdekin Water Board area
- Goulburn Murray Water (1997a) The Underground Flood
- Goulburn-Murray Water (1997b) Groundwater Management Plan – Background Paper
- Hallows, P.J. & Thompson (1995) The History of irrigation in Australia, ANCID, Victoria Vincent and Dempsey (1991) Conjunctive water use for irrigation; good theory, poor practice, ODI, 51 p.
- Heuperman, A.F. (1988) The Tongala groundwater pumping/re-use project: A pilot study for groundwatertable control in the Shepparton Region in Northern Victoria, *Agricultural Water Management*, 14: 513-523
- IIMI and ACIA (1997) Project proposal: Conjunctive water management for sustainable irrigated agriculture in South Asia, Project LWR1/97/16 of IIMI and ACIAR
- Lawson and Van der Lely (1992) Coleambally deep bore report: Analysis of Long term pumping test, NSW Department of Water Resources, Technical Services, Leeton
- Ministry of Foreign Affairs, The Netherlands (1998) Sustainable Irrigated Agriculture, Policy and Best Practice document
- Murray-Rust, D.H. & E. van der Velde. (1994) Conjunctive use of canal and groundwater in Punjab, Pakistan: Management and policy options, *Irrigation and Drainage Systems* 8 (4): 201-232.
- NBWB (1998) Profile of the North Burdekin Water Board, 1965-1998, information brochure
- Prasad, T. & Verdhen, A. (1990) Management of Conjunctive Irrigation in Alluvial Regions-Issues and Approaches, AIT
- Prasad, A, Christen, E.W. and Khan, S. (2001) The potential role for deep groundwater pumping in the control of irrigation induced salinity in the Riverine Plain: A case study of the Coleambally Irrigation Area. Technical Report 01-01. CSIRO Land and Water, Griffith, NSW, 2680
- Raju, K.V., J.D. Brewer, and R. Sakthivadivel (1994) Farmer-Managed Groundwater Irrigation with the Eastern Gandak Irrigation System in Bihar, India, vol. 6 of the Final Report of the Program on Farmer-Managed Irrigation Systems and Support Services Phase II, International Irrigation Management Institute, Colombo.
- Sampson, K (1996) Irrigation with saline water in the Shepparton Irrigation Region, *Australian Journal of Soil and Water Conservation*, Vol. 9: 29-33

SBWB (1998a) South Burdekin Water Board 97-98 Annual Report

SBWB (1998b) South Burdekin Water Board Information Pamphlet July 1998

SWBW (1999) South Burdekin Water Board Ratebook for the year 1999-2000

Sinclair Knight Merz (1997) North and South Burdekin Water Boards, Burdekin River Issues

SPACC (1989) Shepparton Irrigation Region Land and Water Salinity Management Plan Draft

Trewhella, B. (1993) Meeting notes of the sub-surface drainage technical workshop- 28 September 1993

Van der Lely, A. (1994) Coleambally L&WM Plan Regional options, NSW Department of Water Resources, Technical Services, Leeton

Part V

Group Discussions



Dr. Asad Sarwar Qureshi, (center), Chairman of the Session
Dr. Hammond Murray-Rust, (right), Facilitator
Ms. Vilma Horinkova, (left), Rapporteur

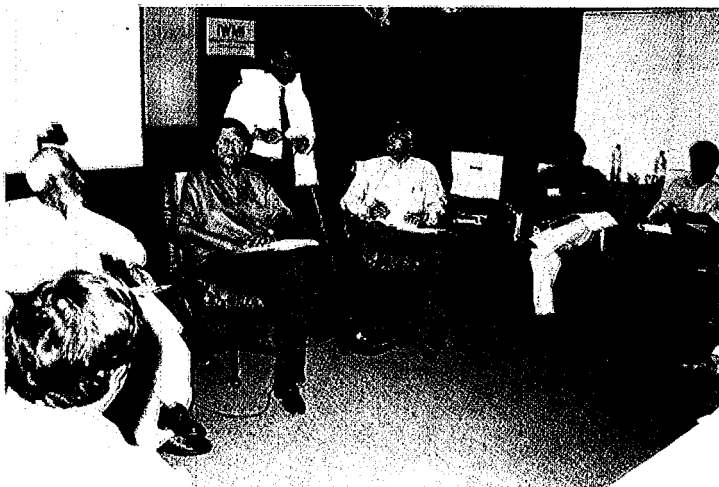

Reports of Group Discussions

GROUP I: MODELING ASPECTS OF CONJUNCTIVE WATER MANAGEMENT

This group focused its discussion on the development and use of simulation models as a management tool for the management of surface and groundwater resources. They identified three specific challenges:

1. Purpose for which models should be used.
2. Scaling of the model.
3. Availability of needed data.

The group noted that models could play an important role in the development of following scenarios:

- Estimation of safe yield for different hydrogeological conditions. Inverse modeling can be used to find sustainable ranges and spatial and temporal variability of safe yields.
- Evaluation of the impact of the use of different quality water for irrigation on soil salinization. It should also cover recycling issues and response of shallow groundwater aquifers.
- Crop irrigation requirement and sustainable exploitation rates.

To translate the modeling results for large-scale applications, following factors may be considered:

- Externality effect
- Socio-economic consideration of different locations
- Situation analysis of different agro climatic conditions
- Long-term effects of different interventions on groundwater behaviour, surface flow variations, crop production etc.

The group considered a proper database as the foremost requirement for successful model application. The data will be needed to define various model input parameters. Further data collection may also be needed to validate model results and refine interpretations. Another important requirement is the capacity building of scientists from local national organizations. The essential data requirements for conjunctive water management modeling may include:

- Spatial and temporal variation in groundwater quality particularly with depth
- Hydrogeological conditions of the area
- Digital elevation points (Drainage System and canal distribution system points)
- Surface water monitoring
- Water use practices at farm level

The group stressed the need for a comprehensive review of work already done on conjunctive water management and shall delineate the results in terms of different groundwater quality zones for irrigation use, domestic use and industrial use. This review should also identify the knowledge gaps

and thrust for future research. The results of the modeling studies should be translated into messages for easy understanding of farmers, policy makers and water managers. This information should be disseminated and discussion should be promoted about proposed and possible measures among users, local authorities and other stakeholders. Criteria should be developed for selection of intervention measures. This is a key but difficult process.

GROUP II: TECHNICAL ASPECTS OF CONJUNCTIVE WATER MANAGEMENT

This group considered two questions:

1. What are the main technical issues for effective conjunctive water management?
2. What are the knowledge gaps and thrust areas for future research?

The technical issues identified by the group include:

- Cyclic use of saline groundwater.
- Mixing of sodic groundwater.
- Use of amendments (i.e. gypsum) for management of sodic water and soils.
- Minimize redistribution of salts in shallow groundwater by improving skimming of fresh water – technology and operation.
- Translate research finding into useable package.
- Mechanism for transferring of groundwater management knowledge.
- Rational distribution of canal water.
- Managing abstractions and rainwater.

The group discussed all these issues one by one, reviewed the existing knowledge and identified areas where further research is needed for effective conjunctive water management. This includes both farm and regional level needs. The key future research areas include:

- Comparative advantage of different amendments in terms of cost-effectivity and stability. The amendment may include chemical, biological and microbiological.
- Further refinement of skimming well technology and tube well operation strategies.
- Survey to document effects of drought on salinity and waterlogging – drought and conjunctive water use.
- Monitoring to refine water quality criteria / standards.
- Review and analysis of past work done on technical aspects of conjunctive water use and synthesis of research results and finding for transfer and identification of gaps for future research thrust.
- Impact of interventions / projects in irrigated agriculture.
- Recharge potential studies in collaboration with irrigation department.
- Database development and management.

GROUP III: ECONOMICAL/INSTITUTIONAL ASPECTS OF CONJUNCTIVE WATER MANAGEMENT

The task of this group was to highlight socio-economic and institutional issues affecting conjunctive water management and make recommendations, for achieving the twin goals of increasing

agricultural productivity and poverty alleviation. The main socio-economical and institutional issues identified by the group include:

- Increase in pumping costs due to declining groundwater tables – mining of groundwater as in upper Rechna Doab.
- Scarcity of canal water, which is forcing farmers to extract poor quality groundwater to supplement their irrigation supplies. This is adding huge amount of salts in the rootzone and aggravating the problems of soil salinization.
- Selection of crops is not according to the quantity and quality of available water.
- Ineffective institutional arrangements to control and regulate surface flows and groundwater abstraction.

The group spent some time in discussion on conjunctive water managements, its linkages with poverty and need for institutional reforms to make following recommendations:

- Canal water allocation should be reconsidered on the basis of groundwater quality zones. In the areas where groundwater quality is fresh and enough reserves are available, canal water allocations can be reduced. This saved water can be diverted to the saline groundwater areas. While doing so, new mechanisms need to be developed to satisfy different sections of the society.
- Crop diversification should be introduced and should be based on economic, ecological and social comparative advantage. For saline groundwater zones, new income generating crops should be introduced and marketing strategies should be developed. Individual entrepreneurs must be developed, targeted to the poor.
- Planned investment should be directed to capacity building and human – resource development initiative in poor rural communities. Farmer organizations should be empowered to take lead in managing and regulating surface and groundwater resources. Mechanisms should be developed to support farmer organizations to undertake these tasks.
- New institutional models need to be forged to link poor smallholder communities with more dynamic sectors of the economy.
- Coordination between different water management institutes need to be strengthened.

Part VI

**Open Day
&
Model Demonstration**

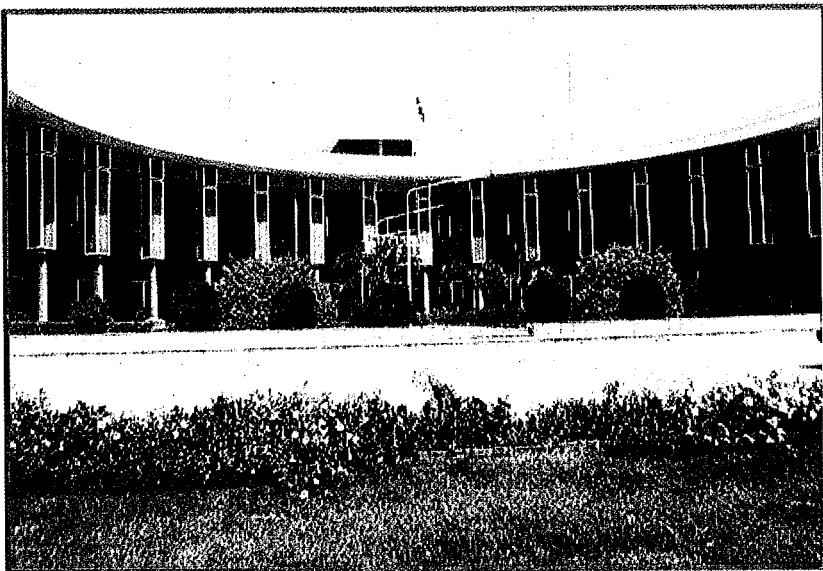

IWMI – Regional Office Lahore, Pakistan

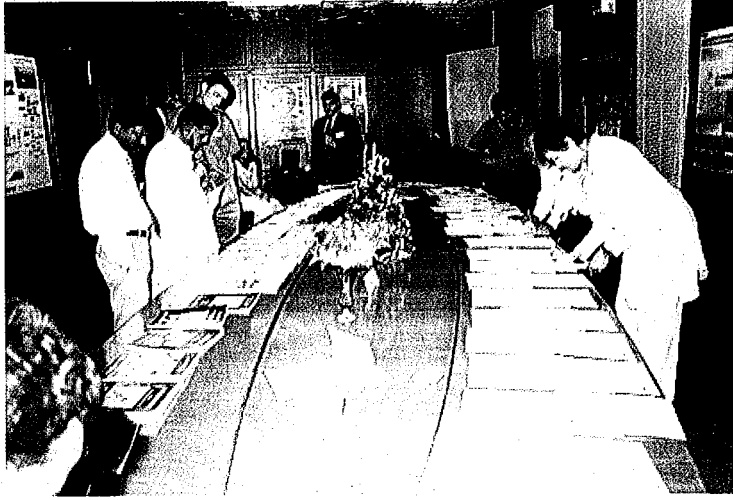

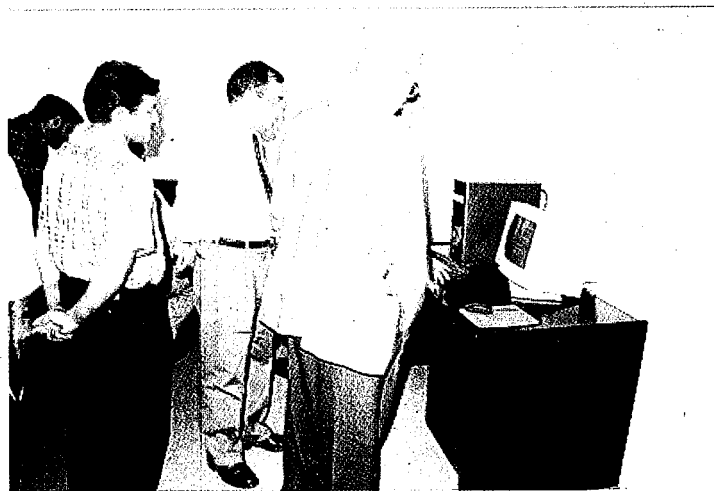
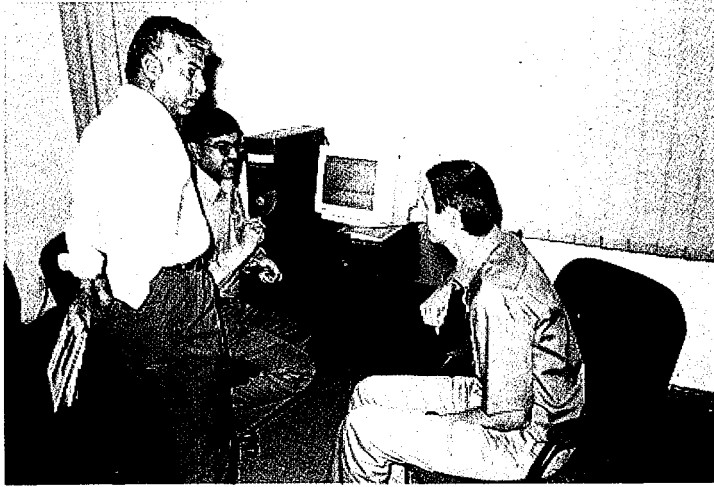

List of Participants

S.#.	Name	Designation	Organization	Phone / Fax	Email
1	S. B Hassan	Advisor	M M Pakistan	5721054	
2	M. Iqbal Chaudhry	Team Leader	M M Pakistan	5721054	
3	Dr. Ahmad Saeed	MMP	Consultant	5721054	
4	Abdul Hamid	Social Scientist	IWMI	723331	a.hamid@cgjar.org
5	Nazim Ali	Agri. Economist	IWMI	723331	n.ali@cgjar.org
6	Ch. M. Ramzan	Chief Agronomist	NESPAK	5884655	
7	Syed Akhtar Hussain	Chief Engineer	CRBC, I&P Dept.	5884655	
8	Waqar Ahmed Farooqi	Sr. Hydrologist	ACE	5759417	aceron@brain.net.pk
9	Muhammad Sadiq	Director	SMO WAPDA	6810471	
10	Dr. M. Latif	Director	CEWRE	6822558	
11	Ahmed Nawaz	Pr. G	NESPAK	7842986	
12	Dr. G. Saeed Khan	Director	SSP	7831010	
13	Niaz Ahmed	Hydrologist	NESPAK	5867235	
14	Ijaz Ahmed Humayun	CE	BARQAAB		
15	Badruddin Soomro	Chairman	PARC		
16	Shaid Ahmed	M (NR)	PARC	9202136	
17	Dr. Zahid Hussain	Director	WRI	9255022	
18	Arshad Khan Niazi	CE	Irrigation Dept.	9200273	
19	Muhammad Yasin	PSO	WRI, NARC	9255022	
20	Yawar Hamid	DTL	PDC/NDP	9202424	
21	Dr. M. Mehboob Alam	PD	MONA Project	0455-42756	
22	Gul Muhammad Shah	Project Manager	COMSATS	9203103	
23	Abdul Rauf	Regional Director	PCRWR	5430484	
24	Dr. W. Flugel	PR	IWMI		
25	Nasar I. Dody	Consultant	World Bank	5863244	
26	Amanullah Qureshi	PD (WRPO)	WAPDA	9202690	
27	Muhammad Aslam	Water Quality Spec.	NESPAK	5160500	
28	Ghulam Nabi Aziz	D (CA)	WAPDA	9202587	
29	Gauhar Rehman	Reg. Manager (N)	MMP	5725474	
30	Abdul Rehman	Director	WAPDA	9202211	
31	Dr. M. Ashfaq	Agri. Economist	IWMI		
32	Fouzia Shahin	Social Scientist	IWMI		
33	M. Rafiq Khan	Social Scientist	IWMI		
34	Mushtaq A. Gill	DG	OFWM	9200703	mushtaqgill@hotmail.com
35	Rashid Khan	RO	GEA Lahore	5421378	Rashid_66pk@yahoo.com

S.#	Name	Designation	Organization	Phone / Fax	Email
36	M. Rshid	Director	SAWER	0573-569365	
37	Dr. M. Bhutta	DG	IWASRI		bhutta@brain.net.pk
38	Vilma Horinkova	Director	IWMI (Central Asia)		
39	Dr. A. b. Sufi	Director	IWASRI	5303061	
40	Dr. M. Ramzan Cahudhry	Director	IWASRI		
41	M. Mazher Saeed	Asst. Prof.	CEWRE, UET	6822024	
42	Ghulam Nabi	Asst. Prof.	CEWRE, UET	6822024	
43	Ghulam Hassan	Director	Soil Salinity Inst.	531376	
44	Dr. Masil Khan	Project Officer	WWF-P	5862360	mkhan@wwf.org
45	Dr. Nazir Hussain	Agri. Chemist	SSRI	0438-531376	
46	Samia Ali	RS/GIS Spec.	IWMI		
47	Karamat Ali	DLR Ph.	I & P Dept.	6823025	
48	Jafar Kabir Ansari	CE	I & P Dept.	9212092	
49	Ghulam Qadir	Director (Hyd)	I & P Dept.	9212092	
50	Dr. Rai Niaz Ahmed	Associate Prof.	UAF	649858	niazrai@yahoo.com
51	Dr. M. Akhtar Abbas	A. P.	UAF	628371	Akhtar6@yahoo.com
52	Dr. Allah Bukhsh	Assist. Prof.	UAF	645150	
53	Z. A. Bukhari	Executive			
54	Farah Rafiq	Representative	Raasta	6667659	raasta@brain.net.pk
55	Salman Latif		Met. Dept.	4587964	
56	Waqar Ahmed		Met. Dept.		
57	Abdul Muzeeb	Director	ISRIP	6823275	
58	Syed Riaz Ali Shah	Sr. Engineer	ISRIP		
59	Syed Qasim Ali Shah	Asstt. Prof.	Govt. Eng. Academy	5421593	
60	Dr. M. Javed	R.S.	I & P Dept.	6823025	
61	Dr. Riaz Mann	SSO	PARC	7981974	riazmann@hotmail.com
62	Dr. Shahzad Afzal	RO	I & P Dept.	9210776	Iri_lhr@yahoo.com