



AgEcon SEARCH

RESEARCH IN AGRICULTURAL & APPLIED ECONOMICS

The World's Largest Open Access Agricultural & Applied Economics Digital Library

This document is discoverable and free to researchers across the globe due to the work of AgEcon Search.

Help ensure our sustainability.

Give to AgEcon Search

AgEcon Search

<http://ageconsearch.umn.edu>

aesearch@umn.edu

*Papers downloaded from **AgEcon Search** may be used for non-commercial purposes and personal study only. No other use, including posting to another Internet site, is permitted without permission from the copyright owner (not AgEcon Search), or as allowed under the provisions of Fair Use, U.S. Copyright Act, Title 17 U.S.C.*

No endorsement of AgEcon Search or its fundraising activities by the author(s) of the following work or their employer(s) is intended or implied.

Planters and their Components

Types, attributes, functional requirements,
classification and description

J R Murray, J N Tullberg and B B Basnet

School of Agronomy and Horticulture, University of Queensland, Australia



Australian Centre for International Agricultural Research
Canberra 2006

The Australian Centre for International Agricultural Research (ACIAR) was established in June 1982 by an Act of the Australian Parliament. Its primary mandate is to help identify agricultural problems in developing countries and to commission collaborative research between Australian and developing country researchers in fields where Australia has special competence.

Where trade names are used this does not constitute endorsement of nor discrimination against any product by the Centre.

ACIAR MONOGRAPH SERIES

This series contains the results of original research supported by ACIAR, or material deemed relevant to ACIAR's research and development objectives. The series is distributed internationally, with an emphasis on developing countries.

© Australian Centre for International Agricultural Research, 2006

Murray, J R, Tullberg, J N and Basnet, B B. 2006. Planters and their components: types, attributes, functional requirements, classification and description. ACIAR Monograph No. 121.

ISBN 1 86320 462 8 print

1 86320 463 6 online

Edited by Anne Burgi, Substitution, Melbourne, Australia

Cover design, Sam Highley, Clarus Design, Canberra, Australia

Printing, Elect Printing, Canberra, Australia

Table of Contents

Section 1: Introduction.....	7
Section 2: Crop establishment.....	8
2.1 Overview of crop establishment.....	8
2.2 The agronomic requirements for crop establishment.....	10
2.2.1 Agronomic requirements for germination.....	10
2.2.2 Agronomic requirements for emergence.....	15
2.2.3 Agronomic requirements for establishment.....	19
2.3 Planter functional requirements for crop establishment.....	24
2.4 Planter classification and description.....	25
Section 3: Planter classification.....	26
3.1 Classification parameters.....	26
3.1.1 The number of rows planted.....	26
3.1.2 The method of attachment to, and the type of, power source.....	26
3.1.3 The type of planter.....	27
3.2 Examples of planter classification.....	29
3.2.1 A broadcast planter.....	29
3.2.2 A drill planter.....	29
3.2.3 A precision planter.....	30
3.2.4 A dibble planter.....	30
Section 4: Planter component parts.....	31
Section 5: Planter soil-engaging components.....	32
5.1 Group 1 – Soil and residue cutting devices.....	34
5.1.1 Functional requirements of soil and residue cutting devices.....	34
5.1.2 Operational requirements of soil and residue cutting devices.....	35
5.1.3 The types of disc coulters soil and residue cutting devices.....	36
5.2 Group 2 – Row preparation devices.....	40
5.2.1 Functional requirements of row preparation devices.....	40
5.2.2 Operational requirements of row preparation devices.....	41
5.2.3 The types of row preparation devices.....	42
5.3 Group 3 – Furrow opening devices.....	51
5.3.1 Functional requirements of furrow openers.....	51
5.3.2 Operational requirements of furrow openers.....	51
5.3.3 Types of furrow opener.....	52
5.4 Group 4 – Seed firming devices.....	81
5.4.1 Functional requirements of seed firming devices.....	81
5.4.2 Operational requirements of seed firming devices.....	81
5.4.3 Types of seed firming devices.....	82
5.5 Group 5 – Seed covering devices.....	84
5.5.1 Functional requirements of seed covering devices.....	84
5.5.2 Operational requirements of seed covering devices.....	84
5.5.3 Types of seed covering devices.....	85
5.6 Group 6 – Row specific seedbed firming devices.....	93
5.6.1 Functional requirements of row specific seedbed firming devices.....	93
5.6.2 Operational requirements of row specific seedbed firming devices.....	94
5.6.3 Types of row specific seedbed firming devices.....	94
5.7 Group 7 – Non row specific seedbed firming/levelling devices.....	102
5.7.1 Functional requirements of non row specific firming/levelling devices.....	102
5.7.2 Operational requirements of non row specific firming/levelling devices.....	102
5.7.3 Types of non row specific seedbed firming/levelling devices.....	103

Section 6: Planter furrow opener depth control components	106
6.1 Functional requirements of furrow opener depth control mechanisms.....	107
6.2 Operational requirements of furrow opener depth control mechanisms.....	107
6.3 Types of furrow opener depth control mechanisms	108
6.3.1 ‘Frame section gauging systems’ for furrow opener depth control	108
6.3.2 ‘Individual row gauging systems’ for furrow opener depth control.....	111
Section 7: Planter seed metering components	118
7.1 Functional requirements of seed metering devices.....	118
7.2 Operational requirements of seed metering devices.....	118
7.3 Types of seed metering devices	119
7.3.1 Mass flow seed metering devices	120
7.3.2 Precision seed metering devices	127
7.4 Selection of seed meter type	141
Section 8: Planter seed delivery components.....	142
8.1 Functional requirements of seed delivery systems	142
8.2 Operational requirements of seed delivery systems	143
8.3 Types of seed delivery systems.....	144
8.3.1 Gravity drop seed delivery systems	144
8.3.2 Mechanically assisted seed delivery systems.....	145
8.3.3 Pneumatic seed distribution and/or delivery systems	147
Section 9: Examples of planter description.....	153
9.1 Example 1 – A broadcast planter.....	154
9.2 Example 2 – A drill planter	155
9.3 Example 3 – A precision planter	156
9.4 Example 4 – A dibble planter.....	157
Section 10: Planter classification and description keys	158
A key for planter classification.....	158
Section 11: Conclusion	165
Section 12: Further information	166
Section 13: Bibliography	167
Index.....	171

Foreword

Sustainable improvement in the livelihoods of poor farmers in developing countries depends largely on the adoption of improved, resource-conserving cropping systems. These systems will often be based on methods involving zero tillage bed planting, but adaptation is usually needed to suit local soils, crops and conditions. It is vitally important that this technology, already used in many parts of the world, be adapted easily to the low-resource situation.

A major constraint to adoption of improved resource-conserving cropping systems in developing countries is the lack of simple planting equipment. While most of the necessary components already exist, information on the availability, attributes and performance of equipment is lacking and effective communication between scientists can be difficult.

ACIAR is publishing this compendium to help address the problem. The authors combined the extensive planting equipment experience of Mr J R Murray from the School of Agriculture and Horticulture at the University of Queensland with the machinery systems knowledge of Dr J N Tullberg and the database skills of Dr B B Basnet.

An immediate obstacle to developing the manual was the absence of adequate, comprehensive and uniform terminology to describe both planting machines and their components. For example, all machines used for crop establishment from seed are referred to here as 'planters', although in some parts of the English-speaking world they are usually referred to as 'seeders' or 'drills'. Machinery component terminology is even more complex, with many of the terms used meaning totally different things to different people, even within the same country. The inclusion of pictures helps solve this problem.

This manual provides a valuable reference for research and extension personnel engaged in the selection, adaptation and/or construction of complete planters appropriate to specific soil, crop, climate and residue conditions.

The manual may also be freely downloaded at www.aciar.gov.au.



Peter Core
Director
Australian Centre for International Agricultural Research

Acknowledgments

Many people have been involved in the lengthy process of initiating, encouraging, funding and executing this work. It started from a group discussion at the 2000 ISTRO conference in Fort Worth, Texas, and the subsequent formation of an ISTRO working group on the development of zero tillage bed planting equipment for lower resource areas. This involved about 20 scientists and engineers with major encouragement for a comprehensive database on planting machinery coming from Dr John Morrison (ISTRO president) and both Dr Ken Sayre and Mr Peter Hobbs of CIMMYT.

Dr Tony Fischer of ACIAR was similarly enthusiastic and arranged funding to support the work, which is closely aligned with an ACIAR objective of facilitating the introduction of more productive and sustainable cropping systems to improve the livelihood of rural communities. Dr Christian Roth subsequently took over administrative responsibility for the project and has shown considerable fortitude in the face of ongoing delays in bringing it to completion.

Contributions by way of constructive comments from Dr Willem Hoogmoed (Wageningen Agricultural University, the Netherlands) on the structure and from Dr Jack Desboilles (University of South Australia) on the content of this book are acknowledged.

A major aspect of this work was the capture, editing and enhancing of photographs to support the identification and classification of planter components. The authors acknowledge the significant assistance provided by Heather Murray (Lockyer Catchment Centre) in this regard.

The authors hope that this work makes a useful contribution to the ultimate purpose of facilitating discussion on, and the development of, improved planting equipment, particularly for more sustainable and productive cropping in low resource areas.

SECTION 1

Introduction

The planting operation is one of the most important cultural practices associated with crop production. Increases in crop yield, cropping reliability, cropping frequency and crop returns all depend on the uniform and timely establishment of optimum plant populations.

There are two broad areas in optimising plant establishment. First, plant breeders, seed growers and seed merchants have a responsibility to provide quality seed. Second, farm managers must be aware of the agronomic requirements for optimum plant establishment and be able to interpret this information in a meaningful way so as to assist with the selection, setting and management of all farm machinery, especially planters.

In this book, the agronomic requirements for plant establishment are reviewed and their implications for planter selection and management noted. On the basis of this information, the functional requirements of a complete planting machine are listed, with elaboration of the soil-engaging, depth control, seed metering and seed delivery components. The types of devices used to accomplish these functional requirements are then described and their relative attributes for crop establishment discussed. Throughout the book, the emphasis is on planter components for crop rather than pasture production.

SECTION 2

Crop establishment

2.1 Overview of crop establishment

In biological terms, crop establishment is the sequence of events that includes seed germination, seedling emergence and development to the stage where the seedlings could be expected to grow to maturity.

Establishment depends on the complex interaction – over time – of seed, soil, climatic, biotic, machinery and management factors (Wood, 1987).

Considering machinery and management (as inputs), climatic constraints (as risk) and the duration of establishment (as rapid or protracted), Gramshaw *et al* (1993) postulate a family of establishment probability curves for Australian crop and pasture production systems (Figure 1). This illustrates that the nature of planting system changes from ‘low input – high risk – protracted establishment’ to ‘high input – low risk – rapid establishment’. Extensive dryland (high risk) pasture establishment (protracted) using over-sowing without seedbed modification or seed treatment (low input) is near the origin (curve 1). Intensive, irrigated (low risk) crop establishment (rapid), using precision planters and water injection (high input) represents the other extremity (curve 6). The intermediate curves (curves 3 and 4) are typical of the establishment outcomes for dryland, broadacre sorghum and sunflower production in the major grain growing areas of Queensland, Australia (Radford and Nielsen, 1985).

The consequences of sub-optimal crop establishment on farm profitability include yield reductions, replanting costs, foregone sowing opportunities, reduced weed suppression, and the direct and indirect effects of secondary germinations (Blacket, 1987).

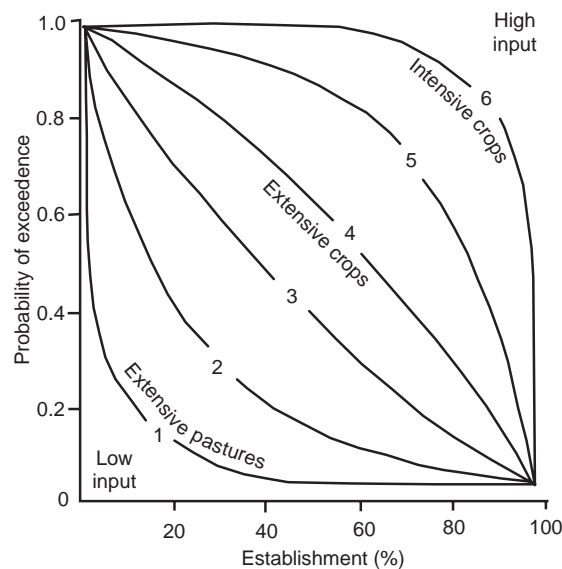

Figure 1: Generic family of probability curves for plant establishment
(Source: Gramshaw *et al.*, 1993)

The variables influencing plant establishment can be broadly grouped as:

- seed/species characteristics;
- the external physical, chemical and biotic environment; and
- management.

The environmental and management variables are closely interlinked. Many management actions (e.g. irrigation, fertiliser application, pesticide application, etc) modify the environment and some (e.g. harvest technique, seed storage method, pre-plant seed treatments, etc) may directly modify seed properties (Gramshaw *et al.*, 1993). The selection, setting and operation of planting machinery directly influence seedbed conditions and may modify seed properties through, for example, mechanical damage.

In crop production systems, establishment potential is primarily dependent on the conditions prevailing immediately prior to planting (essentially, the quality of the seed lot to be used and the seedbed environment as determined by the interaction of soil, climatic and biotic factors) and weather influences during the establishment period (Wood, 1987; Miller *et al.*, 1993). The planting machinery is usually critically important in crop establishment. Planting machines modify the pre-existing seed and soil conditions, and dictate seed placement within the seedbed. The pre-existing conditions can be improved or impaired as a result.

An essential requirement of effective machinery management is to identify the main components of these machine-soil-seed interactions. By understanding these relationships, those responsible for the planting operation can select, set and operate the machines to best meet the agronomic requirements for establishment (Tessier *et al.*, 1991a).

The following section discusses the agronomic requirements for crop establishment. The purpose is not to make an exhaustive study but rather to identify the principal machine-seed/soil interactions so as to provide a basis to:

- identify the functional/operational requirements of planting machinery;
- select machine components in relation to cropping system requirements; and
- set and manage planting machines.

2.2 The agronomic requirements for crop establishment

Establishment involves a continuum of phases and processes. In the broadest sense, the continuum starts with seed production and ends when the next generation is established (Gramshaw *et al.*, 1993). Dividing the continuum into the distinct phases of germination, emergence and establishment oversimplifies the establishment process. It is done here partly because germination and emergence are readily identifiable points in the continuum and partly for convenience of discussion. A limitation of this approach is that seed factors, in particular, exert a major influence over all phases (Fenner, 1992).

2.2.1 Agronomic requirements for germination

Germination is the stage of seedling development when active growth first becomes evident. The germination process begins with the uptake of water by the seed (imbibition) and culminates with the start of elongation of the embryonic axis, usually the radical (Bewley and Black, 1982). In practice, a seed is considered to have germinated when the radical has emerged 2–3 mm from the testa (Wood, 1987). Seeds initially absorb water by a physical process and, while oxygen demand increases towards the latter stages of the germination phase, no soil-derived nutrients are required (Collis-George, 1987). Both germination and the rate of water uptake are temperature dependent. The major agronomic requirements for germination can be grouped as either seed factors or as environmental factors influencing water and oxygen availability and temperature.

Seed factors

Seed quality and pre-sowing seed treatments are the major seed factors influencing germination.

Seed quality

Purity, viability, vigour and health are the four facets determining seed quality for planting (Brocklehurst, 1985). Purity, the proportion by weight of intact seeds of the species to be planted, (Perry, 1982) and seed health, the freedom from pests and disease, (Brocklehurst, 1985) have obvious effects on germination. In addition to a potential reduction in viability, damaged seed is more likely to be invaded by pathogens while in storage or in the field because one of the important barriers to infection – the seed coat – is not intact (Murray *et al.*, 1987). Cracked testae can reduce germination because of the leakage of electrolytes from the seed during imbibition (Brocklehurst, 1985).

Viability is a measure of the percentage of seeds in the seed lot that are capable of producing normal seedlings under optimum conditions. Viability is quantified by a standard germination test conducted under laboratory conditions. However, there is often a poor correlation between germination test results and subsequent field performance. Heslehurst and McDonald (1987) conclude that germination tests could provide a good basis for legislation in the seed trade, but their role in production agriculture is largely restricted to assessing whether or not a seed lot is worth sowing.

Seed vigour is defined as the sum total of those seed properties that determine the potential level of activity and performance of the seed or seed lot during germination and seedling emergence (Perry, 1992). Vigour testing provides information that can be used to help manage seed lots in storage and under specific sowing conditions (Heslehurst and McDonald, 1987). Research has shown that seed vigour is influenced by a myriad of factors, including the planting date of the parent plant, the environmental conditions during seed development, harvest date, harvest technique, seed storage

conditions, age of the seed and pre-sowing seed treatments (Brocklehurst, 1985; Perry, 1982; Adam *et al.*, 1989). While predictive vigour tests are still being developed, seed size is known to have an important influence on seed vigour (Brennan and Henry, 1987).

Most species show considerable variation in seed size and shape and many studies have shown that the larger seeds exhibit marked establishment advantages. The reviews of Benjamin (1990) and Fenner (1992) show that, within species, larger seeds tend to produce bigger, more competitive seedlings that emerge earlier, establish faster and often produce more seed at maturity. Large seeds have enhanced likelihood of emergence because of their ability to successfully establish from a greater sowing depth.

Pre-sowing seed treatments

A diverse range of pre-sowing seed treatments are used to remove several soil, climatic and hydrological constraints. Physiological treatments that improve or enhance seed performance are based primarily on seed hydration, with or without the addition of chemicals. Non-physiological treatments can remove mechanical, soil and environmental constraints and they directly or indirectly improve seed germination and plant establishment. Such treatments include seed scarification, pelleting and treatment with bioactive chemicals (Khan, 1992). In all cases, these treatments aim to mobilise the seeds' own resources or to augment them with external resources to maximise establishment outcomes.

As a group, these seed and seed-related factors dictate the potential for, and influence the rate of, germination. As environmental conditions for germination deteriorate, the rate of germination has a significant influence on the final outcome because the intervention of pests, diseases and, in many situations, low moisture availability are all time dependent.

Environmental factors

For successful germination the microenvironment around the seed must provide a suitable temperature regime and adequate supplies of both water and oxygen. Light is a requirement for germination in only a few plant species (Unger and Stewart, 1976).

The seed must imbibe water at a sufficient rate to reach critical water content before other environmental stresses, such as soil drying or insect/disease infestation, affect the germination process (So, 1987).

The oxygen requirement for germination varies among plant species. Those with a low surface-to-volume ratio (e.g. peas) are the most susceptible to low concentrations (Unger and Stewart, 1976; Cannell and Jackson, 1981). Initially, the oxygen requirements are low and can be supplied from air retained in the seed tissue or the soil, even under waterlogged conditions. Just prior to germination the respiration rate increases and any oxygen in the soil is quickly consumed. If adequate supplies are not replenished by diffusion, through pores connected to the soil surface, the emerging embryo or radicle will die. Nevertheless, most seedbed conditions provide adequate oxygen concentrations for rapid germination. Exceptions would include very dense or waterlogged seedbeds or seedbeds with wet surface crusts (So, 1987; Collis-George, 1987; Unger and Stewart, 1976).

The rate and duration of moisture supply to the seed are of prime importance to successful germination. The rate of supply depends on seed and soil factors as well as soil moisture content. Essentially, the rate of supply to the seed increases with increasing soil moisture content but depends on the moisture characteristic for the specific soil, i.e. the relationship between moisture content and moisture potential (Unger *et al.*, 1981). Soil density has important implications for moisture transfer in the soil. In saturated conditions, conductivity is higher at lower bulk densities due to the larger pore spaces available but, as the soil becomes unsaturated, the conductivity becomes dependent on the number of

contact points between soil particles. On this basis, So (1987) concludes that, for a particular soil type and physical condition, there is an optimum soil density that will best service the seed's requirement over the range of soil moisture expected in the field. The rate of water movement into the seed depends on factors such as its internal moisture potential (relative to that of the soil), the permeability of the seed coat and the surface area of the seed that is in contact with the soil. While the effect of seed/soil contact is still unresolved (So, 1987; Rogers and Dubetz, 1979), it is generally agreed that the transport of moisture to the seed in the liquid, rather than vapour, form is more rapid (Collis-George, 1987).

The duration of water availability to the seed will depend on the soil's initial water content in the seed zone and subsequent changes due to infiltration or drying. There are a range of strategies to extend the availability of moisture to the seed and so improve the prospects for germination, emergence and establishment. For example, reducing soil disturbance at time of planting reduces the potential for moisture loss in the seed zone. First, disturbance tends to mix the drier surface layers into the seed zone. Second, wet soil deposited on the soil surface dries rapidly due to a reduction in drying constraints. Third, disturbance reduces the bulk density of the seedbed. At low densities, i.e. loose or cloddy soil, the large surface results in high evaporative losses, but the upward flow from the underlying layers is limited by the low conductivity associated with low bulk density. When seeds are sown at a depth that corresponds to the interface between the area of high evaporative loss and the area of low conductivity, they will have limited water availability (Hayes, 1985; Wilkins *et al.*, 1981).

Residue mulches have the potential to increase infiltration and reduce evaporative losses. Their effects on both improving germination and establishment and prolonging the available planting time after an effective rainfall are well documented (Hayes, 1985; Radford and Nielsen, 1983a; Unger and Stewart, 1976; Martin and Felton, 1983). Planting techniques that enable seeds to be planted deeper in the seedbed while maintaining optimum depth of cover have also demonstrated advantages (Ferraris, 1992). The moisture content is usually greater at depth and planting deeper in the bed insulates the seed from the adverse effects of drying. Planting deeper and optimising soil density in the seed zone also improves seed/soil contact and aids in the transfer of moisture to the seed (Ferraris, 1992).

Soil temperature is a significant factor influencing all phases of crop establishment. In the broadest sense, temperature dictates crop suitability to a particular geographic region and the planting period within that region. More specifically, all stages of crop growth have a well-defined minimum, optimum and maximum temperature range for growth and development. The usual responses are an approximately linear increase in rate with increasing temperature from a threshold to a maximum, with or without a plateau, followed by a linear decline (Benjamin, 1990). During the initial stages of imbibition, the uptake of water is temperature dependent, as is the initiation of shoot and root growth (Collis-George, 1987). Temperature strongly influences the transformation of nutrients in the soil and the subsequent uptake and assimilation in the plant.

Surface mulches, tillage, irrigation, etc, form the basis of management strategies to modify soil temperature.

In practice, greater diurnal variation occurs at shallow depths and the mean temperature at depth lags behind mean surface temperature. Temperature fluctuations may be a requirement for germination in some pasture species, but have little influence on most cultivated species within the minimum/maximum acceptable range (Benjamin, 1990).

Soil strength and the presence of toxic substances in the soil can have detrimental effects on germination. For example, in soils with high bulk density in the immediate seed zone, soil strength may restrict seed expansion during the imbibition stage and reduce the rate of germination (So, 1987).

Fertiliser placed close to the germinating seed can retard the rate of germination or even kill the seedling. The main factors influencing fertiliser toxicity are the type and rate of fertiliser, proximity to the seed, soil moisture level, soil texture and the seed species (Carter, 1969; Cook and Scott, 1987).

Leachates from decomposing crop residues can also be toxic to plant growth. This phytotoxicity appears to occur when residues decompose on the soil surface close to the seed or growing seedling. Wheat sown through cereal residue is particularly susceptible. Uniform spreading of residues over the soil surface or displacement of residue away from the seeded row are sometimes recommended to reduce the adverse effects (Elliott *et al.*, 1978).

Implications for planter performance

The implications of the agronomic requirements for germination on aspects of planter performance are discussed below.

Seed factors

Seed quality has major implications for seed metering devices. Substantial increases in planting rate to compensate for low seed viability can impair the performance of seed meters, particularly precision seed metering devices (Norris, 1982; Halderson, 1983; Agness and Luth, 1975).

Variations in seed size and shape can also influence planter performance. Some precision seed metering systems (e.g. plate type) require uniformity in both size and shape for optimum performance; others (e.g. vacuum disc type meters) will tolerate a range of seed size and shape without a significant reduction in metering performance (Heyns, 1989; Zulin *et al.*, 1991). Large and/or fragile seeds may be more easily damaged by seed metering devices. For example, Fenner (1992), discussing the advantages of large seed with respect to vigour, etc, reports that the largest 10% of bean seeds often suffer mechanical damage so the mid 80% are the most productive. Evaluating rotary cone, inclined plate, vacuum disc and finger pick-up metering systems for peanut production, Norris (1982) concluded that:

- seed damage increases with meter speed and/or seed size;
- seed meter performance is reduced as meter speed and/or seed size increases; and
- the maximum recommended operating speed of vacuum and finger pick-up units severely limits operating speed when planting large seeds, such as peanuts, at the recommended spacing.

Pre-sowing seed treatments can improve or impair seed metering performance. Pelleting small or light seed to increase their size or weight can improve performance and is particularly useful for precision planting (Scott, 1989). Pre-sowing treatments can be used to improve the seed metering performance when planting 'chaffy' seeds (Lock, 1993). However, pre-soaking seed before planting may impair metering performance if the seeds tend to cling together or become more susceptible to mechanical damage (Radford, 1983b). Some material used in seed treatment may directly reduce the performance of seed metering units. For example, residue accumulation in the holes or cells of the metering plates or discs may increase friction, accelerate wear or simply reduce the efficiency of seed selection/pick-up.

Environmental factors

Planter soil-engaging components have a major influence on optimising environmental factors for germination. The discussion here is restricted to the influence of planter components on the soil immediately adjacent to the seed.

To optimise moisture availability to the germinating seed, the planter must open a furrow, place the seed in the furrow, cover the seed and firm the seedbed. Opening a furrow enables the seed to be planted at a depth where moisture conditions are generally more favourable than those at the soil surface. It is of particular importance in regions where high evaporation rates after rainfall promote rapid drying of the surface layer (Maiti and Carrillo-Gutierrez, 1989). Covering the seed and firming the soil around it helps to stabilise temperature and moisture availability conditions, and protects the seed from predators such as birds and ants.

The degree of soil disturbance in the seed zone during the furrow opening process has a major influence on moisture availability to the germinating seed. The nature and degree of disturbance is largely a function of furrow opener design (Wilkins *et al.*, 1981). When crop establishment is the first priority, the degree of disturbance should be restricted to that necessary to obtain sufficient tilth to help cover the seed, ensure sufficient seed/soil contact, and, where necessary, ameliorate the growth-retarding effects of hard soil (McLeod *et al.*, 1992; Mead *et al.*, 1992; Payton *et al.*, 1985). In general, smaller seeds require finer seedbed tilth for optimum germination and establishment (Hadas and Russo, 1974). Disturbance in excess of these requirements increases the potential for:

- moisture loss from the seed zone through increased evaporation (McLeod *et al.*, 1992);
- mixing of wet and dry soil in the immediate seed zone (Wilkins *et al.*, 1981); and
- reduction in water conductivity from lower in the profile (Hayes, 1985).

In deep, loose seedbeds, the opener can be selected so as to firm the base of the furrow, as this tends to confine seed to a narrower vertical band and improve the prospects for the upward movement of water from the subsoil.

Opener design should be such that:

- the seed is placed in or on the moist soil at the base of the furrow; and
- dry soil is not placed immediately on the top of the seed during the covering phase.

When planting through crop residues, the furrow opener and/or covering device should not incorporate residue in the seed furrow. The incorporation of residue in the furrow can reduce the degree of seed/soil contact (Unger and Stewart, 1976), interfere with the seed-covering process and increase the possibility of phytotoxic effects.

Seedbed firming devices should be selected and set so as to optimise soil density in the seed zone for seed/soil contact, the movement of water to the seed and the minimisation of net moisture loss from the seed zone (Hayes, 1985; Radford and Nielsen, 1985; Schaaf *et al.*, 1981). Firming the seedbed can also reduce the incidence of insect damage (Murray *et al.*, 1987) and prevent the seeds from being pushed out of the soil by the elongating radicle (Unger and Stewart, 1976).

Major disturbance to the seedbed occurs when full-width cultivation is needed for weed control at the time of planting. To avoid sowing the seed at the interface between the tilled and untilled layers, the tillage and planting functions should be separated by depth. The ground tools acting as furrow openers should be modified or set slightly deeper than those performing tillage only (Blacket, 1987). This ensures that the seed is placed below the tillage depth and in relatively undisturbed conditions. The general concept of separating tillage and seeding depth is illustrated in Figure 2.

From research to date, it would appear that opener design has little direct effect on temperature in the seed zone (Tessier *et al.*, 1991a; Wilkins *et al.*, 1981).

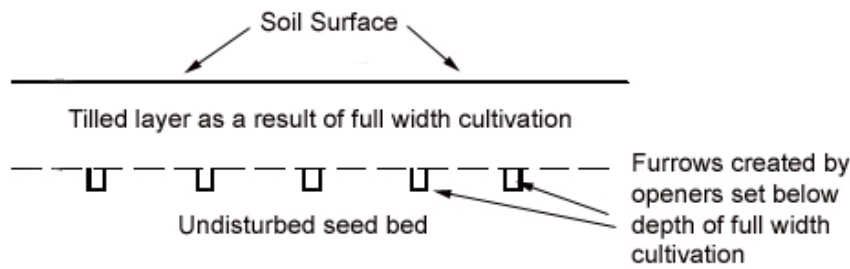

Figure 2: The concept of separating tillage and seeding functions

2.2.2 Agronomic requirements for emergence

Emergence, when the developing seedling emerges through the soil surface (Wood, 1987), is one of the most easily observed events in crop development (Benjamin, 1990). Between germination and emergence, the seed must contain enough stored mineral nutrients to sustain growth until the developing root system has made sufficient contact with the soil to take over the nutrient supply function. The seed must also contain enough stored carbon assimilates to sustain growth until the shoot has emerged and an effective photosynthetic area has been established (Asher, 1987).

Many of the agronomic requirements for germination continue to play an essential role in this and subsequent stages and are included in discussions below. The dominant features of this stage are root and shoot growth and development. Factors influencing the growth and movement of roots and shoots in soil adjacent to the seed zone become important, as do factors influencing nutrient supply to, and uptake by, the developing root system.

Root development/elongation

Radical and root development/elongation are subject to a similar range of limiting factors as germination. Even if temperatures are suitable and nutrients adequate (given the importance of seed reserves), there may be limitations as a result of inadequate supply of water and oxygen, excessive soil strength and the presence of toxic substances (So, 1987).

Soil structure is known to influence the size and shape of roots (Braunack and Dexter, 1989) but there are few correlations between crop performance and soil structure. This is because root systems do not respond to changes in bulk density or porosity unless they are associated with changes in water content, air content, soil temperature or root impedance (Brown, 1970; Braunack and Dexter, 1989).

Once germination is completed, the pattern of water use changes. The moisture potential of the seed has approached that of the adjacent soil and the rate of imbibition has reduced (Asher, 1987). The water required for shoot and root growth is now largely obtained via the seminal, and subsequently nodal, roots. As the demand for water and nutrients increases, the roots have to explore new soil. To move in the soil, the roots exploit existing soil pores of suitable size or create new pores by overcoming soil strength as the growing tip moves forward. In general, under all but favourable conditions, the survival of the developing seedling depends on root elongation proceeding faster down the soil profile than the drying front. Soil properties known to restrict root growth include mechanical resistance, coarse dry layers, inadequate aeration and extreme acidity (Heinonen, 1985). Under field conditions, mechanical impedance or a dry layer of soil are the more common restrictions to root growth. Mechanical resistance, or soil strength, increases with bulk density and this increase is more rapid at lower water

contents. Therefore, decreasing water content in the soil affects root growth indirectly, largely through the effect of increased soil strength (So, 1987). The incidence of high soil strength and dry soil layers has significant implications for the selection and management of planting machinery.

Shoot development and emergence

Elongation of the shoot towards the soil surface is subject to limitations similar to those for root elongation. Shoots are, however, more sensitive to soil mechanical resistance (So, 1987) so depth of planting and soil strength are major factors affecting both the rate of emergence and the final emergence percentage.

Until the seedling has emerged and developed an effective photosynthetic system, growth depends on seed reserves. If planted too deep, the seed reserves are depleted before emergence can occur and the seedling dies. Further, as the length of the developing shoot has to increase with the depth of planting, the combined effects of a reduced cross-sectional area and the increased tendency to buckle, reduce the effective axial force the seedling can exert. Limited by both energy reserves and the reduced capacity to exert axial force, seeds planted at depth have little chance of emergence through high strength soil surface layers.

The ability of seeds to emerge from depth and/or of seedlings to penetrate high strength soil layers is somewhat dependent on the type of organs present in the embryo. Emergence results from either coleoptile or mesocotyl elongation in the monocotyledonous species or by epicotyl or hypocotyl elongation in dicotyledonous species (Brennan and Henry, 1987).

The post-germinal processes in, for example, barley and wheat involve the extension to the surface of the coleoptile, the protective cover over the first leaf. If the coleoptile fails to reach the surface before splitting, to allow leaf emergence, the prospects of emergence are small because the leaf has little ability to penetrate soil. Coleoptile length is genetically controlled and is correlated to established plant height (Brennan and Henry, 1987). Emergence failure with short wheat varieties has been widely reported and attributed in many cases to excessive planting depth (Blacket, 1987; Radford, 1982; Riethmuller, 1990).

In sorghum, the coleoptile is less well developed and extension of the mesocotyl is the important emergence method. Sorghum genotypes show a large variation in mesocotyl length and therefore their ability to emerge from greater planting depths (Maiti and Carrillo-Gutierrez, 1989). Further, mesocotyl elongation is sensitive to soil temperature, a reduction in length occurring at higher temperatures. Higher seedbed temperatures can therefore influence final emergence percentage, particularly in the case of deeper plantings (Brennan and Henry, 1987).

In dicotyledonous species, the developing seedling reaches the surface through elongation of either the epicotyl (hypogeal emergence) or the hypocotyl (epigeal emergence). In the former, the cotyledons remain below the surface and in the latter, they are pushed through the soil surface during emergence. Pushing the cotyledons through the surface of higher strength soils is difficult for the establishing seedling and is a recognised limitation to the establishment of crops such as soybean (Brennan and Henry, 1987).

Loose soil over the seed can, by virtue of light penetration, promote sub-surface leaf emergence (Blacket, 1987). Once the coleoptile splits and the leaves are exposed, emergence failure is common because of the inability of the leaves to exert sufficient force to penetrate the surface layer.

Particular problems arise where soils have a tendency towards hard-setting or surface crusting.

Hard-setting is a condition associated with soils with high silt and fine sand fractions and low organic matter (So, 1987). Aggregation is weak and, on wetting, these soils tend to slake or disperse, the fine particles filling the pore spaces between bigger aggregates to form a dense matrix. On drying, the surface quickly develops high strength and this impedes or restricts emergence and subsequent infiltration.

Crusting is a similar condition generally resulting from aggregate breakdown due to raindrop impact. On drying, a hard, thin crust develops on the soil surface.

When hard-setting and crusting conditions set in before emergence, poor plant stands usually result (Awadhwal and Thierstein, 1985; So, 1987). A stratified seedbed with finer aggregates in the seed zone covered by coarser aggregates near the soil surface reduces both the drying rate and the hazards of surface crusts (Awadhwal and Thierstein, 1985).

Implications for planter performance

For rapid and successful germination, planting depth and soil conditions in the immediate seed zone need to be optimised, primarily to ensure moisture availability to the seed. While moisture availability remains crucial during the establishment phase, planting depth and soil conditions are important factors for root elongation and shoot emergence. The implications of these aspects for planter performance are discussed below.

Control of planting depth

Planting depth is a major determinant of seedling emergence and hence one of the most important operational requirements of a planting machine (Rainbow *et al.*, 1992). Inadequate depth control accuracy is recognised by farmers (McGahan and Robotham, 1992) and researchers (Riethmuller, 1990) as a major deficiency of current broadacre planting machines. Providing planting machines capable of maintaining uniform depth under field conditions is a major challenge for equipment designers (Thomas, 1984; Janke and Erbach, 1985), particularly under direct drilling conditions because of the greater surface roughness and variability of soil structure and residue levels (Baker, 1977; Morrison and Gerik, 1985).

Optimum planting depth has two essential components: the depth of the furrow relative to the original soil surface and the depth of soil covering the seed. The depth from the original soil surface has implications for the level and likely duration of moisture availability to the seed. The depth of soil cover over the seed has implications for emergence. When there is adequate moisture in the surface layer, furrow depth can be set to optimise depth of cover for emergence. However, when it is necessary to plant deeper to ensure seed is placed in moist soil the resultant depth of cover can limit emergence. A number of techniques can be used to resolve this conflict. For example, soil in excess of that required to optimise depth of cover can be moved into the inter-row space by a suitable device preceding the opener. Figure 3 shows the general concept of this approach.

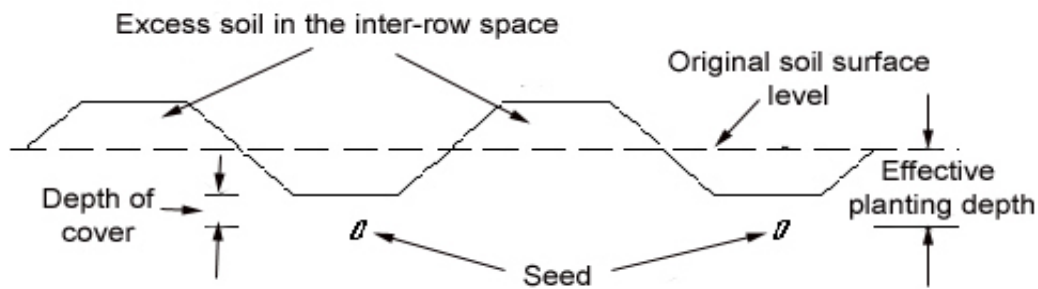

Figure 3: Alteration of soil surface profile to facilitate planting deeper to moisture

When a crop is to be planted on raised beds or ridges the ability to effectively remove dry surface layers is enhanced because the excess soil can be placed into the inter-bed or inter-ridge space. Conversely, under cold or wet conditions the ridges tend to warm up and dry earlier than would be the case with flat land planting and planting can proceed earlier than otherwise possible (Hayes, 1985).

Press wheels can also be used to modify the depth of cover in addition to firming the seedbed, particularly where full-width cultivation for weed control is performed at time of planting. Under these conditions, the press wheels substantially reduce the depth of cover and give a higher degree of uniformity in the depth of cover (Blacket, 1987; Rainbow *et al.*, 1992; Ward, 1987). The depression over the seeded row as a result of press wheel action can have an additional advantage. Where there is low-intensity, short-duration rainfall after planting, the surface profile tends to concentrate runoff in the depression immediately above the seeded row and improve the moisture status around the emerging seedling (Blacket, 1987; Ward, 1987). Where more significant rainfall events occur, the concentration of moisture above the seeded row may kill seedlings as a result of waterlogged conditions. Further, if soil is moved into the depression as a consequence of side-wall slumping or erosion, the resulting depth of cover may restrict emergence (Rainbow *et al.*, 1992).

Where full-width cultivation is practised or where close row spacings are required at planting, the interaction of soil displacement between adjacent openers can cause uneven depth of cover between adjacent rows. On a multi-bar machine, soil movement from adjacent openers on subsequent bars can influence the depth of cover over the seed sown by openers on preceding bars (Slattery and Rainbow, 1992). The use of narrow openers to reduce sideways movement of soil is one solution. Where the average planting depth and the optimum depth of cover are similar, re-levelling the seedbed surface after seed placement is another solution (Palmer *et al.*, 1988).

An additional confounding factor is the differing ability of opener designs to place seed in a defined zone relative to the base of the furrow created (Wiedemann *et al.*, 1971; Rainbow *et al.*, 1992; Choudhary *et al.*, 1985). Seed displacement or vertical scatter about the mean depth results from the shape of the furrow created and the design of the seed delivery/placement system (Agness and Luth, 1975; Norris, 1978; Norris and Ryan, 1983).

Soil conditions

The furrow opener modifies conditions in the seedbed. The aim of opener design and selection is to ensure these modifications improve, rather than impair, conditions for emergence. In most cases, this is achieved by ensuring disturbance to the seedbed is kept to a minimum.

In firm seedbeds, the opener should be selected so as not to compact the base or walls of the furrow to the extent that root extension into the adjacent soil is restricted. In wet seedbeds, particularly in soils

with high clay content, smearing of the base and walls of the furrow should be avoided. Smeared layers tend to dry quickly and form a thin layer of high strength. In extreme cases the roots of establishing plants are largely confined to soil within the bounds of the furrow (Choudhary and Baker, 1981). Without follow-up rainfall to reduce the strength of the smeared layers the prospects for plant establishment are poor.

Over-compaction of the soil covering the seed can restrict emergence (Schaaf, *et al.*, 1981), particularly where the surface layer has a tendency to set hard on drying. Press wheel design and setting, in relation to the shape of the furrow and to seed and soil type, are the major factors influencing optimum soil conditions above the seed (Ward and Norris, 1982). To obtain the maximum benefit from press wheels it is important that the wheels track the planted row (Morrison and Abrams, 1978) and have a cross-sectional profile compatible with the furrow shape created by the opener.

Where rainfall immediately after sowing causes hard-setting of the surface layer, management techniques, such as a shallow harrow operation, can minimise the effects on emergence (So, 1987).

2.2.3 Agronomic requirements for establishment

During the establishment phase the seedling becomes independent of seed reserves. A seedling's survival now largely depends on its ability to adapt to changes in its above- and below-ground environment and to compete with other plants for water, nutrients and light. The effects of prior land preparation methods can have a substantial influence on this stage of development. For example, the effects of compacted layers, induced by tillage or traffic, below the seed zone can restrict root growth and moisture movement. Soil nutrient status is dependent on fertiliser applications and previous cropping history.

Plant competition

Competition between plants for water, nutrient and light resources has important implications for establishment. In his review, Benjamin (1990) concluded that the spread in time for seedling emergence accounts for a major portion of the variation in mature plant weight because differences in emergence time have a large effect on seedling size at the point where plants start to compete for growth resources. Time of seedling emergence has the largest effect when the spread is large, the seedlings have a high relative growth rate, the plant density is high and growth to harvest time is short.

Plant population and spacing requirements

The plant population (i.e. the number of established plants/ha) influences the degree to which competition influences crop establishment. In practice, the needs of the individual plants have to be balanced against the requirement to maximise crop yield (Wollin *et al.*, 1987). Agronomic trials have shown that the yield potential of many crop species is dependent on both the established population and the uniformity of spacing of plants within that population.

Many factors have to be considered when determining the optimum population and the spacing (i.e. the distance between rows of plants and the spacing of plants within a row) for a particular crop. The factors affecting potential yield include climatic conditions, time of planting, soil type and soil moisture status. Other factors to be considered relate to the ease of performing cultural practices. For example, row spacing may affect the ease of inter-row cultivation and harvesting. Populations and row spacing may affect weed growth and control, the degree of crop lodging, the size of the seed heads, etc, all of

which may have implications for crop growth, yield and harvest. In crops such as cotton and sugar cane, the row spacing may be dictated by the design of the harvest machinery available.

With some crops (usually unicum types, e.g. sunflower and maize), there is a comparatively narrow range of plant populations from which optimum yields could be expected, given the particular climate, soil type, soil moisture, etc, conditions. For other crops (particularly those that have the ability to tiller, e.g. wheat, barley, oats) there appears to be a wider range of populations over which potential yield does not vary appreciably; the principal requirement from a yield point of view is for a population greater than the minimum value required for the particular conditions.

Spacing of plants, within and between rows, can be important. Many crops can tolerate reasonable variations in the uniformity of plant spacing without a loss in yield potential, provided the overall population is within the required range. With some crops, however, e.g. sunflower, sorghum and most horticultural crops, the yield potential can be improved with uniformity of plant spacing within the optimum population range.

Particular combinations of populations, spacing requirements and placement methods give rise to distinct planting patterns. The range of possible planting patterns used to describe the spatial orientation and placement of seeds planted in the field are briefly discussed below. They include:

- broadcast planting;
- drill planting;
- precision drill planting;
- hill drop planting;
- check row planting; and
- dibble/punch planting.

Broadcast planting

The pattern resulting from the random scattering of seeds on the soil surface (Figure 4).

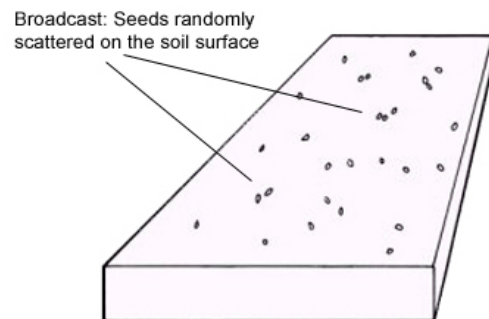

Figure 4: The 'broadcast' planting pattern

Drill planting

The pattern resulting from the random dropping (and subsequent covering) of seeds in furrows to give definite rows of randomly spaced plants (Figure 5).

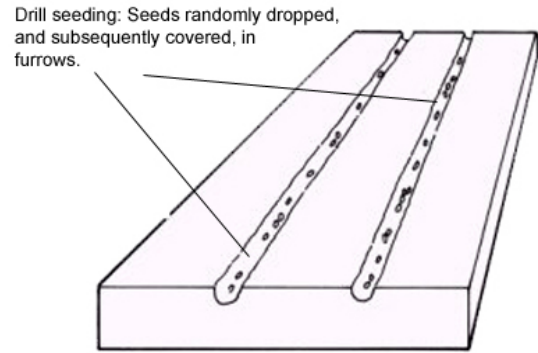

Figure 5: The 'drill' planting pattern

Precision drill planting

The pattern resulting from the accurate placement (and subsequent covering) of single seeds in furrows at about equal intervals to give definite rows of almost equally spaced single plants (Figure 6).

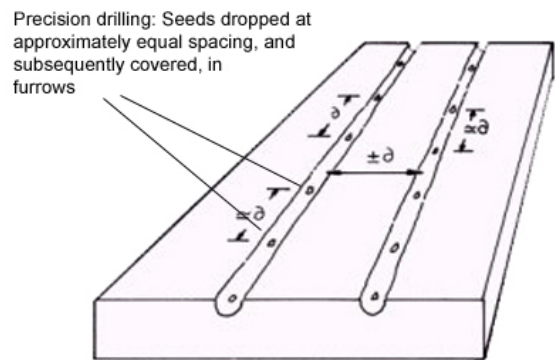

Figure 6: The 'precision drill' planting pattern

Hill drop planting

The pattern resulting from the accurate placement (and subsequent covering) of groups (or hills) of seed in furrows at about equal intervals to give definite rows of almost equally spaced groups of plants (Figure 7).

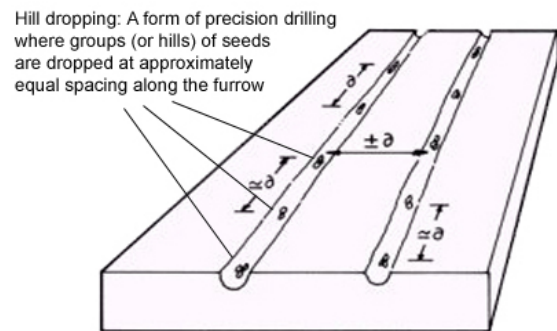

Figure 7: The 'hill drop' planting pattern

Check row planting

The square-grid planting pattern resulting from the accurate and indexed placement (and subsequent covering of seed) of individual seeds or groups of seed. Individual plants, or groups of plants, are spaced equidistant apart and aligned in perpendicular rows (Figure 8).

Check row: A particular form of precision drill seeding where seed spacing along the row is equal to row spacing, and the seeds across rows are aligned to give a symmetrical grid pattern

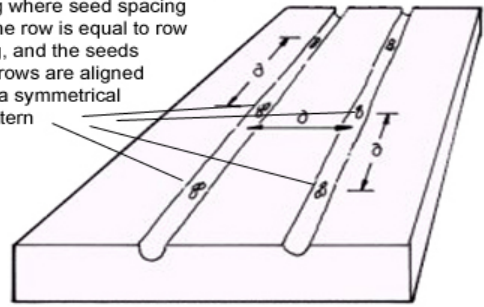

Figure 8: The 'check row' planting pattern

Dibble or punch planting

The pattern resulting from placing single or multiple seeds in individual holes that have been 'punched' or otherwise dug in the seedbed. As Figure 9 shows, the holes are usually aligned to form rows of established plants. Nevertheless, when hand, rather than machine, planting methods are used the holes may be randomly placed over the seedbed surface.

Dibble planting: One or more seeds placed in individual holes that have been punched or dug in the seed bed

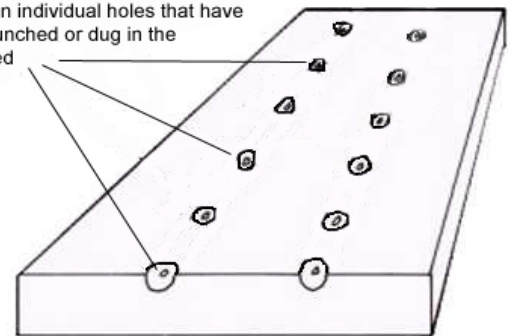

Figure 9: The 'dibble' planting pattern

The need for hill drop and check row planting patterns has diminished over time as a result of improvements in plant breeding, seed harvest and storage techniques, etc. While drill and precision drilling patterns are extensively used, considerable research and development is being directed towards the improvement of dibble or punch planting techniques. In general, this aims to exploit the potential residue-handling benefits that may be gained from punching holes, rather than digging continuous furrows, to enable seed placement within the seedbed.

Where the inter-row space is sufficient to allow cultural practices such as inter-row cultivation, side dressing of fertiliser, etc, the overall system of planting is generally referred to as 'row crop' planting. Where the rows are not this wide, the system of planting is generally referred to as 'solid' planting. Solid-planted crop stands generally result from the use of mass flow seed metering devices that give rise to the 'broadcast' and 'drill' planting patterns. Row crop stands generally result from precision seed metering devices that give rise to 'precision drill', 'hill drop' or 'check row' planting patterns.

The implications of these establishment parameters on planter design and performance are briefly discussed below.

Implications for planter performance

The major implications resulting from plant competition, plant population and plant spacing on planter performance are related to the ability of the machine to meet the inter- and intra-row spacing requirements for establishment.

Inter-row spacing requirements

Inter-row spacing depends on the effective spacing between furrow openers and the horizontal spread of seed within the furrow. Furrow shape and the design of the seed placement components are the major variables. To enable the planter to sow a range of crops it is desirable that row spacing can be adjusted. On wide drill planting machines this is usually accomplished by altering row spacing as a multiple of the overall opener spacing, e.g. blanking off the seed flow to every second opener across the width of the machine effectively doubles the row spacing. On precision type planters, the spacing of the individual openers can usually be adjusted by sliding and repositioning the furrow openers on the toolbar/frame.

Intra-row spacing requirements

Intra-row spacing is a function of the planter's seed meter, seed delivery system and seed placement device.

The seed meter selects seeds from the seed lot and discharges them at a predetermined rate (output) and spacing (accuracy). As previously discussed; the type of seed meter, the quality of the seed lot and the rate of seed metering all influence the actual metering rate and accuracy.

The function of the seed delivery tube is to convey the seed to the opener/placement device, while maintaining as much metering accuracy as possible. The length, cross-sectional shape and area, material of construction and rigidity of the delivery tube all influence the degree to which metering accuracy is maintained (Norris, 1978).

Finally, the seed placement components should place the seed on moist soil at the base of the furrow with minimum bounce/displacement so as to maintain metering and delivery accuracy.

As previously discussed, the design of the furrow opener, the soil type and condition and the speed of operation all influence the accuracy of seed placement.

2.3 Planter functional requirements for crop establishment

To successfully establish crops over the range of conditions likely to exist at planting, a planter should be able to:

- open a furrow;
- meter the seed;
- deliver the seed to, and place the seed appropriately in, the furrow;
- cover the seed in the furrow;
- firm the seedbed; and
- perform other functions as required, e.g. weed control, apply crop chemicals, etc.

These functions must be performed at an acceptable forward speed and with a high degree of reliability. Not all planting machines are capable of performing, nor necessarily need to perform, all the functions. Nevertheless, the ability to perform all functions improves planter flexibility and crop establishment prospects, particularly when sub-optimal crop establishment conditions exist at the time of planting.

The functions performed by the planter's soil-engaging components and its seed metering and distribution system largely determine its overall performance under particular conditions. The types of devices used to perform these functions, together with their functional and operational requirements, are discussed below.

The planter functions undertaken by the soil-engaging components include those associated with 'opening the furrow' (i.e. residue cutting, row preparation and furrow opening devices), 'covering the seed' (i.e. seed firming and seed covering devices) and 'firming the seedbed' (i.e. row and non row specific seedbed firming and levelling devices). Planter functions undertaken by the seed metering and seed distribution components include those associated with 'metering the seed' (i.e. seed metering devices) and 'delivering the seed to the furrow' (i.e. seed distribution and/or seed delivery devices).

2.4 Planter classification and description

Equipment for planting crop and pasture seeds can be broadly classified on the basis of:

- the number of rows planted by one pass of the machine (if applicable);
- the nature of the power source used to propel the machine;
- the method of attaching the machine to the power source (if applicable); and
- the type of planter, based on the resultant planting pattern.

To fully describe the planter, additional machine-specific information is required about:

- soil-engaging components;
- furrow opener depth control mechanism;
- seed metering system; and
- seed delivery components.

To be meaningful, the method of classifying and describing planting machinery needs to be:

- consistent in the approach adopted;
- consistent in the terminology used; and
- readily understood by all with an interest in the area.

Both the classification of planters and the description of their major component parts are discussed in the following sections and proposed 'standard' classification and description keys presented.

Wherever possible the terminology is compatible with existing, related 'standard' information, such as the various standard documents by ASAE (2005).

SECTION 3

Planter classification

Planting machinery can be broadly classified on the basis of a combination, where applicable, of:

- the number of rows planted in one pass of the machine;
- the method of attachment to and the type of power source used to propel the machine; and
- the type of planting machine based on the resultant planting pattern.

These parameters are briefly discussed below and the section concludes with an example of each type.

3.1 Classification parameters

3.1.1 The number of rows planted

The number of rows planted/holes punched per pass of the machine is directly related to how many furrow openers it has. Machines can be classified as single row, five row, 40 row, etc, depending on the number of furrow openers. On multi-row machines, the furrow openers are typically uniformly spaced across the full width of the machine.

3.1.2 The method of attachment to, and the type of, power source

On the basis of the power source used to provide the draft (i.e. the horizontal component of the force required to propel the machine through the soil), planters can usually be classified as:

- human;
- animal; or
- tractor-powered.

Methods of attachment are those that typically see the planter pulled by, pushed by or carried and pulled by the power source.

Human-powered planters

Human-powered planters can typically be categorised as being either:

- hand-held/carried; or
- pulled or pushed.

Animal-powered planters

Animal-powered planters are typically categorised as:

- pulled.

Tractor-powered planters

Tractor-powered planters can generally be categorised as being:

- trailed;
- semi-mounted; or
- front/mid/rear mounted.

Trailed planters are attached to, and pulled by, the tractor's drawbar hitch point. The machine requires its own transport/depth control wheels to provide the additional support required.

Semi-mounted planters are those that are pivotally attached to the tractor's two lower three-point linkage points but also require transport (or depth) wheels positioned towards the rear of the machine's frame to provide additional support.

Mounted planters are attached to, and are capable of being fully supported by, the tractor. Typically, these machines are attached to the tractor via a three-point linkage system located in front of the tractor's front wheels, between the front and rear wheels or behind the rear wheels (front, mid or rear mounted respectively).

3.1.3 The type of planter

Planters can be broadly classified as being:

- broadcast;
- drill;
- precision;
- dibble; or
- specialised.

Broadcast planters

Broadcast planters randomly distribute seed on the soil surface. As the seeds are deposited on the soil surface (i.e. not in furrows created by a furrow opener) an additional operation (e.g. harrowing) may be needed to cover seed. The use of a broadcast fertiliser spreader to distribute seed on the soil surface is the most common example of the broadcast planter. This type of planter is useful for establishing small seeds, particularly those with light requirements for germination (such as some pasture grasses). Broadcast planter types are not generally appropriate for cash crops because of the obvious limitations to controlling or meeting agronomic requirements.

Drill planters

Drill planters randomly drop seeds in furrows to form definite rows of established plants. This type of planter uses a mass flow type seed meter and is extensively used for the establishment of both winter and summer crops where there is no need to place plants equidistant down the rows. For example, almost all cereal crops (oats, wheat, barley, etc) are planted by drill type planters. Reasonably accurate control over the planting rate per hectare can be attained. Drill type planters are often known as solid crop planters because of the narrow row spacing typically used.

Precision planters

Precision planters accurately place single seeds or groups of seed almost equidistant apart along a furrow. They are typically used to plant crops that require accurate control of plant population, and spacing between and along the rows. Crops in this category include almost all the horticultural crops and field crops such as sorghum, maize, sunflower, soybeans and cotton. Precision seed metering systems giving a precision drill, hill drop or check row planting pattern are used on this type of planting machine.

Many of the crops requiring the use of precision planters are grown in summer, are planted in wide rows and have individual seed boxes and associated seed meters for each row. Accordingly, precision planters are often referred to as summer crop planters, row crop planters or unit planters, respectively.

Dibble/punch planters

Dibble planters place a seed or a number of seeds in discrete holes, rather than furrows, dug in the seedbed. Typically, although not necessarily, the holes are equally spaced and aligned so as to form rows. Hand-operated dibble planters are commonly used to establish crops (particularly inter-crops) in small-scale, low-resource agricultural crop production systems. Tractor-mounted, dibble type planters are commonly used in horticulture to plant seeds into seedbeds covered with plastic mulch. To date, few commercial dibble planters have been available for large-scale production systems, particularly where there are crop residues on the seedbed surface at planting. Considerable research is being undertaken to develop such machines because of the potential benefits in improving the ability of planters to handle residue and reducing planter energy requirements.

Specialised planters

Specialised planters are those that do not plant seeds but rather whole plants (i.e. seedling transplanters), plant stems (e.g. sugar cane whole stick or set type planters) or tubers (e.g. potato planters), etc. While specialised planters have many components in common with those that plant seed they are not further discussed in this book.

3.2 Examples of planter classification

The examples of planting equipment shown below are based on the classification parameters described in the preceding section. For consistency, the approach used is to identify and state, where applicable, the number of rows planted, the method of attachment to the power source, the power source then the type of planter. Not all the parameters can always be clearly identified in a single photograph.

3.2.1 A broadcast planter



Figure 10: A hand-held, human-powered, broadcast planter

3.2.2 A drill planter



Figure 11: A 14-row, trailed, tractor-powered drill planter

3.2.3 A precision planter



Figure 12: A single-row, hand-pushed, human-powered, precision planter

3.2.4 A dibble planter



Figure 13: A single-row, hand-held, human-powered dibble planter

SECTION 4

Planter component parts

Planting machines can be considered as an assemblage of components, each designed to meet a particular function, e.g. open a furrow, meter the seed, deliver the seed to the furrow, close the furrow and firm the seedbed.

Planter components can be logically grouped by function into the following categories:

- soil-engaging components;
- furrow opener depth control components;
- seed metering components; and
- seed delivery components.

Identical components can perform different functions (e.g. a disc coultter can be used to cut residue, open a furrow or close a furrow). Further, a given component may be set to achieve different outcomes while performing a specific function (e.g. open a furrow, but able to be adjusted to give varying degrees of soil disturbance). The accurate and meaningful description of planter components requires knowledge of the specific component's:

- type;
- functional characteristics/requirements; and
- operational requirements.

In the following sections, individual planter components are identified and their functional and operational requirements discussed.

SECTION 5

Planter soil-engaging components

The functions performed by the soil-engaging components include opening the furrow, placing the seed, covering the furrow and firming the seedbed.

Where there are high levels of surface residue and relatively unprepared seedbeds, devices to cut or otherwise manipulate soil and residue (row preparation devices) may be required in addition to the furrow-opening device. Similarly, firming/re-levelling the seedbed after seed placement and covering may require the use of a non row specific (i.e. full width) device (such as harrows or rollers) in addition to a row specific firming device (such as press wheels). Soil-engaging components sometimes have several functions, e.g. a single disc coultter used as a furrow opener may also perform a residue and soil cutting function.

The full range of soil-engaging components available for use on planting equipment is classified under seven functional groups:

- Group 1 Soil and residue cutting devices
- Group 2 Row preparation devices
- Group 3 Furrow opening devices
- Group 4 Seed firming devices
- Group 5 Seed covering devices
- Group 6 Row specific seedbed firming devices
- Group 7 Non row specific seedbed firming/levelling devices

The relative position or location of these soil-engaging component groups, in relation to the direction of travel of a planter, is shown in Figure 14.

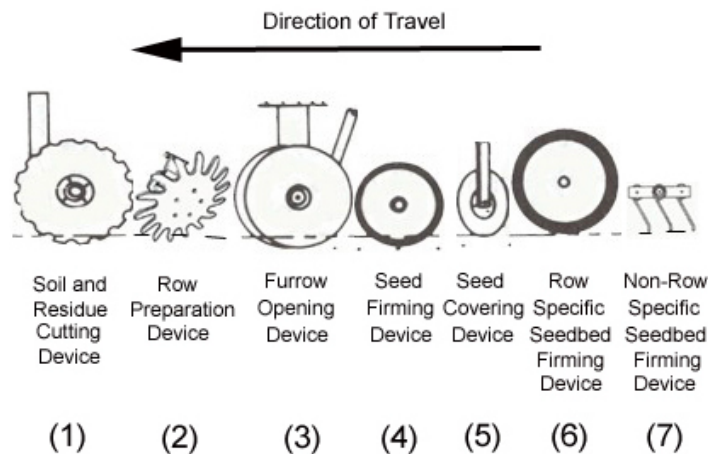

Figure 14: Planter soil-engaging component groups

Many machines are not designed to accommodate, nor have available, devices for all possible groups of components. Nevertheless, a number of more sophisticated, flexible and/or specialised planters used in conservation cropping systems do incorporate all seven groups. The horticultural planter shown in Figure 15 features five of the seven groups. In general, horticultural seedbeds are comparatively well prepared and devoid of high levels of surface residue, which overcomes the need for a dedicated soil and residue cutting device.

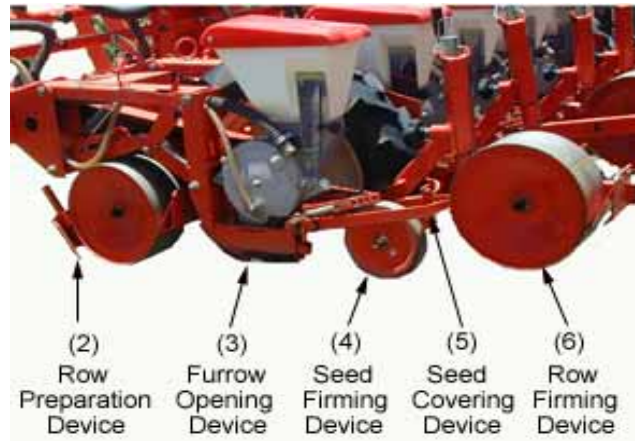

Figure 15: A horticultural planter featuring five of the seven soil-engaging component groups

The functional and operational requirements for each group and range, design and relative advantages and disadvantages of the devices commonly deployed in each group are discussed in detail in the following sections.

5.1 Group 1 – Soil and residue cutting devices

Soil and residue cutting devices are primarily designed to cut soil and/or residue in the row area without significantly disturbing the seedbed. Where required, these devices precede all other planter soil-engaging components. They may be required to orient residue or loosen soil to enhance the performance of the row preparation, furrow opening, seed covering or seedbed firming devices that follow. The nature and extent of the soil and residue manipulation required in addition to the cutting action depends primarily on device selection and, to a lesser extent, setting.

A vertically mounted disc coulters, drawn parallel to the direction of travel, is almost universally used as the soil and residue cutting device on planting machinery. These coulters are most commonly used on planters for conservation cropping systems, particularly where high levels of residue and relatively unprepared seedbed conditions are expected.

There are a range of disc coulters types; their general functional and operational requirements are briefly discussed below.

5.1.1 Functional requirements of soil and residue cutting devices

Essentially, the soil and residue cutting device facilitates the planter's overall performance by cutting and/or otherwise manipulating soil and residue in the row area ahead of the planter's other soil-engaging components.

The major *functional requirements* of disc coulters used as soil and residue cutting devices are to:

- cut crop/weed residue to enable its subsequent removal from directly over the row area or to improve the machine's ability to operate through high levels of surface residue without blockage;
- cut and/or disturb hard soil layers to assist the opener achieve and maintain optimum furrow depth or provide additional soil disturbance (tilth) to improve the operation of planter seed covering and seedbed firming devices; and
- cut soil and/or plant root material to reduce the subsequent seedbed disturbance caused by the furrow opener (particularly positively raked openers).

The residue-cutting function is particularly useful where, for example, residues are to be removed (displaced sideways) from the row area to help manipulate soil temperature or where tine type openers are used under high levels of surface residues. Under conditions where high levels of long residue exist, the performance of tine type openers can be severely restricted by the residue wrapping around, and accumulating on, the standard to which the ground tool is attached. Effective residue cutting by a disc coulters preceding the opener is one solution to overcoming this limitation of tine type openers.

The soil cutting and/or disturbance function is particularly useful where negatively raked furrow opener types (e.g. runner and double disc types) are used under high strength soil conditions or where the furrow opener action does not provide adequate tilth to permit effective soil movement back into the furrow to provide cover after seed placement. Under high strength soil conditions, negatively raked furrow openers have difficulty achieving and maintaining optimum furrow depth. Simply adding weight, i.e. increasing the vertical downwards force, to achieve penetration by such openers can result in over-compaction of both the side walls and the base of the furrow. Effective cutting and disturbance of the soil by a disc coulters preceding these openers can alleviate penetration difficulties and reduce the

potential for over-compaction of the side walls and base of the furrow. Increasing soil tilth, particularly through the use of fluted type disc coulters, can improve the ability of soil to flow or be moved back into the furrow after seed placement and the potential for the seedbed firming device to achieve adequate seed/soil contact.

Pre-cutting soil and plant root material can reduce the subsequent seedbed disturbance caused by furrow openers, particularly positively raked types. The controlled fracture of the soil can substantially reduce the sideways displacement of soil during the furrow-opening process. Pre-cutting root material reduces the possibility of the increased disturbance that may result if plant material wraps around the below-ground portion of the opener, increasing its width and reducing its scouring ability.

5.1.2 Operational requirements of soil and residue cutting devices

The *operational requirements* of disc coulters type soil and residue cutting devices include:

- The design must provide for cutting depths up to twice the optimum seed placement depth, i.e. twice the depth required to be met by the planter's furrow opening components.
- Disc coulters require adequate vertical force, a sharp cutting edge and firm, dry surface-soil conditions to effectively cut residue. In soft soil conditions there is inadequate resistance to achieve the cutting function. Residues are 'hair-pinned' or pushed into the soil rather than cut and retained on the surface. Hair-pinning is exacerbated by a blunt cutting edge and, as well as reducing the performance of the furrow opener, it may seriously reduce germination. Higher soil moisture content, particularly in clay soils, reduces the disc's scouring ability and both its cutting and disturbance performance.
- The diameter of the disc coulters needs careful thought. It is a compromise between achieving effective soil and residue cutting/manipulation and optimising the cost, vertical force and draft requirements. Essentially, the latter requirements increase with disc diameter. However, the disc's ability to perform its residue-handling and cutting ability is limited at both small and large diameters. Under heavy residue conditions, small diameter discs tend to push, rather than cut, residue and large discs have limited penetration capabilities. The compromise is to select a diameter that provides for a rake angle of about 45 degrees at the soil surface when the disc is operating at its intended depth. Optimisation of disc performance usually occurs at diameters about 450 mm.
- The type (shape) of the disc coulters largely determines the balance between the cutting and disturbance functions. In general, discs with a straight cutting edge have lower vertical force and draft requirements and tend to cut soil and residue with minimum disturbance to the seedbed. Disc coulters with a sinusoidal cutting edge have higher vertical force and draft requirements and cause greater disturbance, with an associated reduction in cutting ability.
- For optimum performance, disc coulters should usually be mounted forward of, aligned centrally with, and have provision for vertical adjustment relative to, the opener. A swivel type mounting may be required to reduce the side forces on the disc and to improve 'opener tracking' where planting machinery is not always operated in a straight line of travel.
- The performance of disc coulters can be severely restricted by soil adhesion to the disc, particularly in soils with high clay and moisture contents. While scrapers can be fitted to plain discs (i.e. flat disc coulters) there is no similar option for discs with sinusoidal cutting edges.
- The vertical force required to achieve disc penetration increases with disc diameter and should not be under-estimated, particularly under zero tillage conditions.

5.1.3 The types of disc coulters soil and residue cutting devices

Disc coulters can be broadly classified on the basis of their diameter and the profile of their cutting edge. While there is no uniformly agreed nomenclature, seven types of disc, classified on the basis of the profile of the cutting edge, have been identified: 'plain', 'notched', 'bubble', 'ripple', 'fluted', 'wavee' and 'turbo' (Figure 16).



Figure 16: Types of disc coulters soil and residue cutting devices

While all are used for soil and residue cutting and disturbance, the actual cutting edge on the first three, i.e. the plain, the notched and the bubble types, is straight and narrow in the direction of travel and their primary function is cutting. The sinusoidal cutting edge of the remaining four, i.e. the ripple, fluted, wavee and the turbo types, provides greater disturbance. The major distinction between the four is the number and overall width of the convolutions. Ripple disc coulters have numerous, narrow convolutions and wavee disc coulters have few, wide convolutions. While the cutting edge of the turbo type is fluted, it differs from conventional fluted types in that the grooves are spiralled, not radial. Figure 17 shows the typical profile of the cutting edge on each general type. Their relative merits are discussed below.

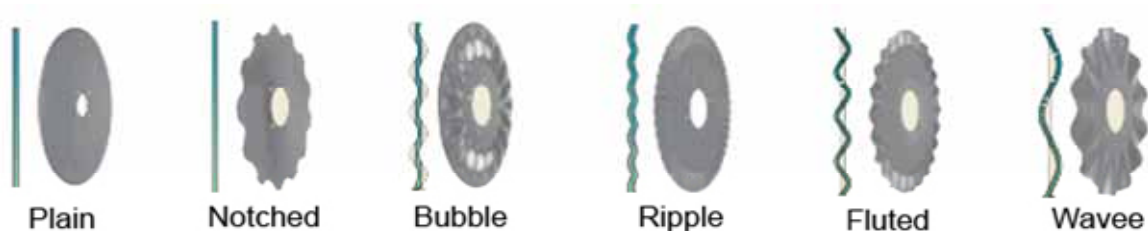

Figure 17: Typical cutting edge profiles for each general disc coulters type

Plain disc coulters

Plain disc coulters are flat circular discs with a sharpened circumference. They have good penetration and residue cutting ability and cause minimum disturbance to the seedbed. However, compared to other types they have a greater potential to stop turning and ‘bulldoze’ residue, particularly under low soil strength/high residue seedbed conditions. Figure 18 shows a plain disc coulters preceding a dedicated tine type furrow opener. The disc has a scraper attached to facilitate operation in moist clay soil types.



Figure 18: A plain disc coulters soil and residue cutting device

Notched disc coulters

Notched disc coulters are flat circular discs with a sharpened, notched circumference. They have similar characteristics to the plain disc coulters except they are arguably more suited for use in very hard soils and very heavy residue situations. Figure 19 shows a notched disc coulters preceding a dedicated tine type furrow opener.



Figure 19: A notched disc coulters soil and residue cutting device

Bubble disc coulters

Bubble disc coulters are circular discs with offsets recessed from the circumference but with a flat sharpened cutting edge. These have similar characteristics to the plain disc coulters but have reduced penetration ability and cause moderate disturbance to the seedbed. Figure 20 shows a bubble disc coulters preceding a double disc coulters type furrow opener.



Figure 20: A bubble disc coulters soil and residue cutting device

Ripple disc coulters

Ripple disc coulters are circular discs with numerous offsets extending radially inwards from the circumference providing a narrow sinusoidal shaped cutting edge. These types have good penetration and cutting ability and provide for moderate disturbance/tilting over a relatively narrow width. Figure 21 shows a ripple disc coulters preceding a narrow tine type furrow opener.



Figure 21: A ripple disc coulters type soil and residue cutting device

Wavee disc coulters

Wavee disc coulters are similar to the ripple disc except the offsets are larger and fewer so the disturbed width is greater. These discs have reduced penetration and cutting ability but cause more disturbance over a greater width compared to ripple disc coulters. Figure 22 shows a wavee disc coulters preceding a dedicated tine type opener.



Figure 22: A wavee disc coulters type soil and residue cutting device

Fluted disc coulters

Fluted disc coulters have a shape and penetration, cutting and disturbance abilities that lie somewhere between those of the ripple and wavee type disc coulters. Figure 23 shows a standard fluted disc coulters preceding a double disc coulters type furrow opener.



Figure 23: A fluted disc type soil and residue cutting device

Turbo disc coulters

Figure 24 shows the principle of operation of the ‘turbo’ type fluted disc coulters. The flute grooves enter the soil vertically and leave horizontally. This action is claimed to aid penetration on entry and provide additional tilth on exit.



Figure 24: A turbo type fluted disc soil and residue cutting device

Disc coulters and soil and residue cutting devices are considered essential for use in many conservation-cropping systems. However, they significantly add to the cost, mass and draft requirements of planting machinery. They should only be used where necessary and not simply used to compensate for poor management practices.

Implementing good soil (e.g. controlling traffic) and residue (e.g. cutting and spreading residues at time of harvest) management practices can significantly reduce the need for, and/or difficulties associated with, the use of planter soil and residue cutting devices.

5.2 Group 2 – Row preparation devices

Row preparation devices are primarily designed to alter surface residue and/or soil conditions to facilitate the operation of the planter's furrow opening device or otherwise improve the prospects for crop establishment. If required, the row preparation devices precede the planter's furrow opening device. When used in conjunction with a soil and residue-cutting device, the row preparation device is fitted between it and the furrow opener.

Row preparation devices may be used on flat, hilled or bedded field surfaces and some incorporate the ability to cut soil and residue. However, row preparation devices incorporating this function are usually capable of causing far more significant displacement of soil and/or residue from the row area than a dedicated soil and residue cutting device.

A large range of row preparation devices is available and they are commonly fitted to planting machines used in both conservation and conventional cropping systems. Their general functional and operational requirements are discussed below.

5.2.1 Functional requirements of row preparation devices

Row preparation devices assist the operation of the planter's furrow opening device or otherwise improve the prospects for crop establishment by performing one or more of the following functions:

- level and/or firm the immediate row area to facilitate furrow opener action and depth control;
- remove dry soil from the immediate row area to allow planting to moisture without excessive soil cover over the seed;
- remove residue from the immediate row area to facilitate the operation of the furrow opener or to, for example, increase in seedbed temperature; and/or
- cut and displace both soil and residue from the immediate row area to achieve a combination of these functions (i.e. the typical action of 'concave disc' type row preparation devices).

The seedbed levelling and firming function is particularly useful when planting small seeds into very friable seedbeds, e.g. a typical horticultural application. The levelling action helps improve depth control and the firming action helps reduce seed displacement (both horizontally and vertically) by closing larger voids and helping prevent soil flowing back into the furrow before seed placement. In conservation cropping systems, the application is similar but more focused on levelling rough, relatively unprepared seedbeds. 'Roller', 'blade' and 'harrow' type row preparation devices are commonly used to perform this function.

Removing dry soil to permit planting in or on moist soil is a common practice in both intensive and extensive cropping systems. This practice is often referred to as 'moisture seeking' or 'planting to moisture' and is used to improve soil water management and/or (particularly in dryland cropping systems) enable an extension of the planting window. By removing dry soil to the inter-row or inter-bed space, the furrow opener can place seed onto the moist sub-surface layer without leaving excessive soil cover over the seed. 'Blade' and 'tine' type row preparation devices are commonly used to perform this function.

Removing residues from the soil surface in the immediate row area is particularly useful in conservation cropping systems where higher levels of residues impede furrow opener performance or depress soil temperatures. Removing the residue with little seedbed disturbance can improve opener performance

and increase soil temperatures without excessive moisture loss from the seedbed. The removal of residue from the immediate row area can also reduce the potential for residue-induced phytotoxic effects in the seed zone. ‘Finger wheel’ and ‘horizontal disc’ type row preparation devices are commonly used to perform this function.

Where large amounts of long residue and/or significant levels of dry soil exist, a combination of residue cutting and soil displacement may be required to achieve similar outcomes. Single or double concave disc type row preparation devices can cut and significantly displace both soil and residue.

5.2.2 Operational requirements of row preparation devices

The diversity of row preparation devices precludes a detailed discussion on their operational requirements. Nevertheless, the following generally apply:

- adequate provision must be available to enable incremental vertical and horizontal adjustment of the device in relation to the furrow opening device and the soil surface;
- with double concave-disc and double finger-wheel types, provision is needed to adjust the discs and wheels independently of each other; both horizontally and laterally;
- with finger harrows, the ability to adjust finger rake angle provides flexibility in both the degree of soil disturbance and the ability to handle a range of surface residue conditions; and
- availability and inter-changeability of types (i.e. finger wheel, disc coulter and tine types) provides flexibility in selecting devices to meet specific soil and residue management requirements.

The ability to quickly and conveniently fit, remove and interchange types and make relatively fine adjustments to their vertical and/or horizontal position cannot be over-valued. For example, the difference between ‘residue displacement’ and ‘residue displacement and soil disturbance’ depends on being able to fine tune the device vertically. On a twin concave disc or twin finger wheel type device, the ability to align, offset or change the angle of the individual discs or wheels to the direction of travel can substantially influence their operational performance.

5.2.3 The types of row preparation devices

Based on their general form and function, row preparation devices can be broadly classified as ‘blade’, ‘concave disc’, ‘finger harrow’, ‘finger wheel’, ‘horizontal’, ‘tine’ and ‘roller’ types (Figure 25). The use of horizontal disc type row preparation devices have been investigated but not used commercially to date. The general role and design variation within each of these general types is briefly discussed below.

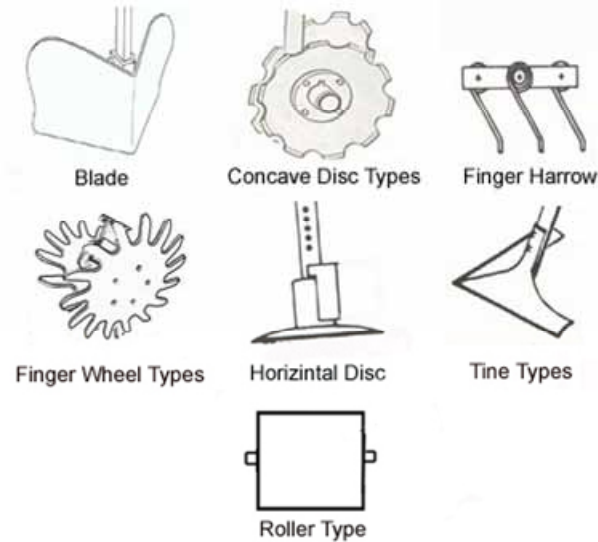

Figure 25: General types of row preparation devices

Blade type row preparation devices

Blade type row preparation devices are essentially used to either level the row area to facilitate opener depth control or remove dry soil to the inter-row space to permit planting to moisture. Most blade type row preparation devices are ‘V’-shaped in the direction of travel (Figure 26).

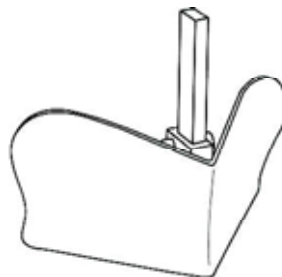

Figure 26: A blade type row preparation device

The use of blade type row preparation devices is usually restricted to intensive cropping systems where well-prepared, weed- and residue-free seedbeds exist.

The blade’s inability to cope with hard soil conditions or any significant level of surface or incorporated residue generally precludes their use in conservation cropping systems. Where there is a requirement to remove dry soil to the inter-row space in conservation tillage systems a double disc type row preparation device is usually used because of its ability to cut and displace both soil and residue.

Figure 27 shows an example of a blade type row preparation device. It shows the front view of the blade mounted in front of a double disc coulter type furrow opener.



Figure 27: Example of a blade type row preparation device

Finger wheel type row preparation devices

Finger type row preparation devices are primarily used to displace residue from the immediate row area to improve the performance of the furrow opening device, reduce the potential for residue induced phytotoxic effects or assist in raising seedbed temperature by removing the residue cover. Often referred to as ‘residue managers’ or ‘trash wipers’, these devices can be either single or double wheel types (Figure 28).

While there are diverse finger designs, the principle of operation is similar. The wheels rotate as a result of contact with the soil and the residue is displaced to one or both sides of the row.

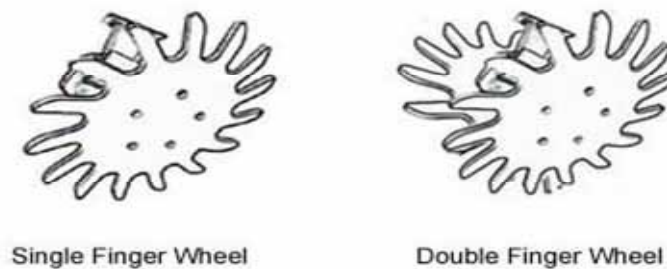

Figure 28: Typical single- and double- finger wheel configurations

While the overall capability and performance of finger type row preparation devices is largely dictated by soil and residue type and condition, the performance under specific condition depends on the particular type of finger wheel and the flexibility of the design to allow for wheel adjustment. Incremental vertical adjustment is required to ensure the optimisation between providing adequate contact with the ground to power the wheel and reducing soil disturbance. The general aim is to provide maximum residue displacement with minimum soil disturbance. For a given forward speed, the angle of the wheel to the direction of travel influences both the speed of wheel rotation and the width of residue displacement. The ability to adjust wheel angle to the direction of travel, the relative position of the wheel or wheels to the centreline of the opener and the relative position of the wheels to each other provides for maximum flexibility to suit specific conditions. The ability to adjust wheel positions on one particular design is shown in Figure 29.



Figure 29: Top views of a finger wheel row preparation device showing the optional wheel positions

The design shown in Figure 30 allows the device to be configured as a single or double wheel type as well as catering for various wheel positions within each configuration.

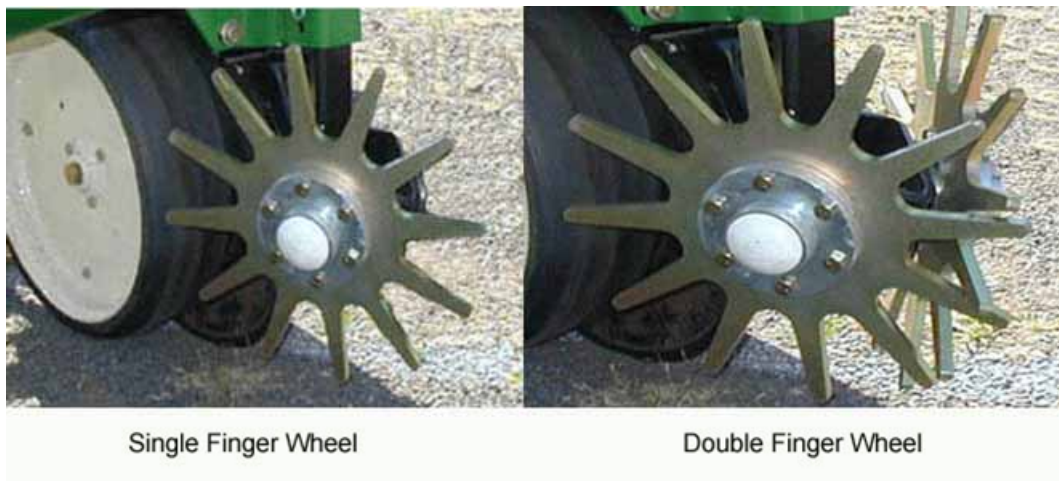

Figure 30: Examples of single and double finger wheel type row preparation devices

Both of the finger wheel types shown in Figure 30 precede a double disc coupler type furrow opener and are optional settings within the one design. While a diversity of finger shapes and sizes are available most operate in a similar fashion. The fingers on most finger wheels used as row preparation devices are rigid, however some manufacturers use spring steel rods (Figure 31).



Figure 31: Spring steel finger wheel row preparation device

To ensure adequate depth, most finger wheel row preparation devices are mounted directly to the frame that controls the depth of the furrow opener or on a separate, pivoted frame mounted forward of the opener frame (Figure 32).



Figure 32: Spring steel finger wheel row preparation device

Concave disc type row preparation devices

Concave disc type row preparation devices are used to cut and displace both soil and residue from the row area. The cutting and displacement action of the concave disc allows for the combined actions of a blade and a finger wheel type row preparation devices under a combination of hard soil and high residue conditions. While primarily used in conservation cropping systems to facilitate opener operation when planting to depth in hard soil and high residue conditions, it may be used in well-prepared seedbeds when gross soil movement is required. A typical example would be to permit a runner type opener to operate at depth, such as required when planting potatoes.

Concave disc type row preparation devices can be single or double disc units. On single units, the discs can be plain or notched (Figure 33). On double concave disc units, the discs can be plain or notched and aligned or staggered (Figure 34). A combination of plain and notched discs may be used sometimes.

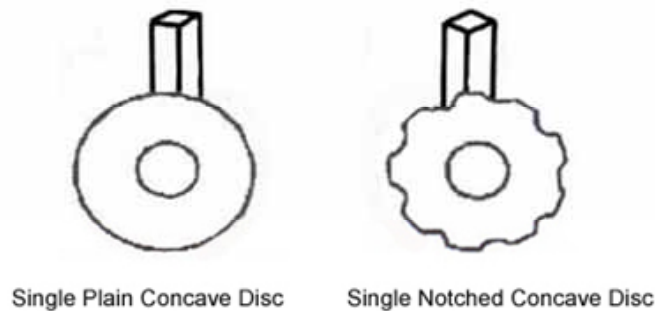

Figure 33: Types of single concave disc row preparation devices

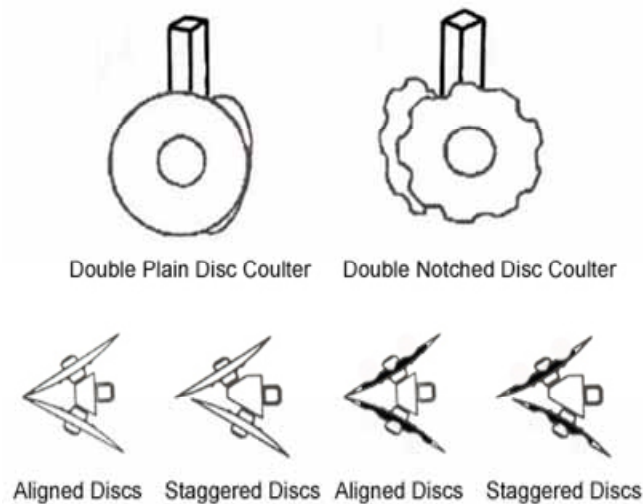

Figure 34: Disc types and alignment for double concave disc type row preparation devices

In general, while notched concave discs have better soil penetration and residue-handling ability than plain concave discs, the wear rate is greater due to the reduced length of the cutting surface in contact with the soil. Given the relatively small diameter of the concave discs used on row preparation devices, a small reduction in diameter due to wear can significantly reduce the disc's residue-handling ability.

When aligned double disc types are used, a section of uncut and undisturbed soil remains in the central row area. While this may have little consequence for the operation of a furrow opener in deep, well-prepared seedbeds, a tine type opener with a positive rake angle is better suited for use in hard soil conditions.

The adjustments required to facilitate use of concave disc coulters over a wide range of conditions are similar to those required for finger wheel types, i.e. provision for both vertical and horizontal adjustment relative to the soil surface and/or furrow opener as well as the ability to adjust double disc alignment and overlap.

Figures 35 and 36 both show examples of double concave disc type row preparation devices. The unit in Figure 35 has a pair of aligned plain discs; the unit in Figure 36 has a pair of staggered notched discs.



Figure 35: An example of an aligned, plain double concave disc coultter type concave disc coultter



Figure 36: An example of a staggered, notched double

Combination of concave disc and finger wheel types

Concave disc and finger wheel row preparation devices may be combined to achieve an action suited to a particular situation. Figure 37 is an example of a row preparation device that combines a notched concave disc and a finger wheel type.



Figure 37: An example combined concave disc and single finger type row preparation device

Finger harrow type row preparation devices

As a row preparation device (rather than a discrete machine or a tillage machine attachment, etc) finger harrows are generally narrow and mounted directly in front of the furrow opener on unit type planters.

When used in conventional cropping systems, i.e. those without surface residues, the main function is either to assist in the control of small weeds or to assist in re-levelling the seedbed to improve furrow opener depth control. In conservation cropping systems, the predominant use is to assist in breaking-up or otherwise spreading surface residues to facilitate overall planter performance. A typical three bar finger harrow unit is shown in Figure 38.

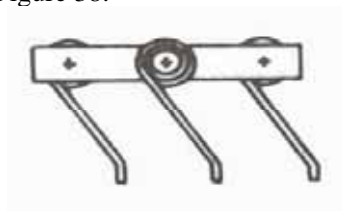

Figure 38: A typical three bar finger harrow unit

In most cases, the bars on which the finger harrow tines are mounted can be rotated to adjust the tine rake angle. Reducing the rake angle reduces soil disturbance and improves stubble handling ability. Figure 39 shows a three bar harrow type row preparation device mounted in front of a double disc coultter type furrow opener.



Figure 39: An example of a harrow type row preparation device

Tine type row preparation devices

The function of tine type row preparation devices is generally restricted to disturbing soil to facilitate the operation of a negatively raked furrow opener (e.g. runner and disc types, particularly aligned double discs); disturbing soil to facilitate weed control in the row area or displacing soil to allow planting to moisture. Because better options exist, tine type row preparation devices are usually restricted to performing these functions over a range of seedbed conditions (i.e. hard or well prepared) where there are low levels of surface residue at planting.

While a diversity of ground-tool types are available, sweep and knife types (Figure 40), are generally deployed as row preparation (as distinct from furrow opening) devices.

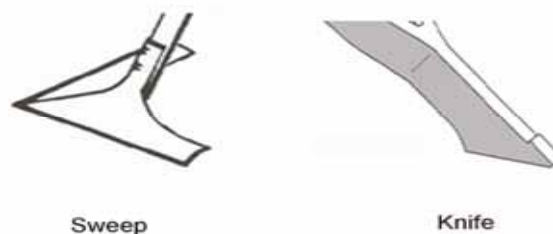

Figure 40: Typical tine type row preparation devices

The knife type is specifically used to disturb a narrow band of soil to depth, so as to allow disc and runner type furrow openers achieve and maintain depth under hard soil conditions.

Wide, low-profile sweeps may be used at a shallow depth to control weeds in the row area, while high profile sweeps can facilitate both weed control and soil displacement. In most cases, soil displacement is used to remove dry soil from the row and permit planting to moisture. Given the range of ground-tool shapes available, the major adjustment for operational performance is provision for vertical and horizontal adjustment.

Figures 41 and 42 show examples of the sweep and the knife type of tine row preparation device, respectively. The sweep precedes a narrow tine type furrow opener in Figure 41 and the knife precedes a double disc coultter type furrow opener in Figure 42.

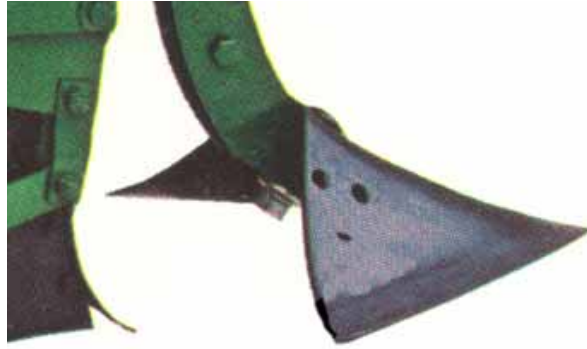

Figure 41: A tine type row preparation device preceding a double disc opener



Figure 42: A sweep type row preparation device preceding a tine type furrow opener

Roller type row preparation devices

The function of roller type row preparation devices is almost exclusively to level and firm deep, well-prepared seedbeds to facilitate opener operation and depth control. In most applications they are not used where there is any significant amount of surface residues. They are rarely used as a discrete device; in most cases the roller is used as part of the furrow opener depth control mechanism.

In the roller type row preparation device in the form of a front furrow opener gauge wheel in Figure 43, it is placed after a blade type row preparation device and precedes a runner type furrow opener.



Figure 43: An example of a roller type row preparation device

Horizontal disc type row preparation devices

The function of horizontal disc type row preparation devices is to remove surface residue and/or soil from the row area to facilitate furrow opener operation. These devices usually consist of a horizontally mounted concave disc combined with shank mounted residue deflectors (Figure 44).

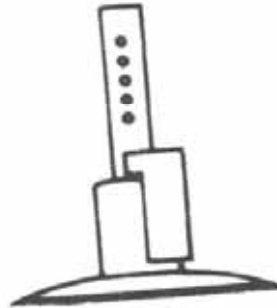

Figure 44: The general form of a horizontal disc type row preparation device

The plane of the sharpened cutting edge of the disc, which is free to rotate, is nearly parallel to the soil surface, but typically inclined at a 10 to 15 degree angle; the leading edge is lower than the trailing edge. As the machine moves forward, contact with the soil causes the disc to rotate. The path width from which residue and/or soil is removed is primarily dependent on the blade diameter, deflector settings and working depth.

The use of horizontal disc type row preparation devices has been investigated by a number of research workers but they are not readily available or frequently used on planting machines. A similar horizontal disc has been successfully used as a discrete device for cutting and removing cotton stalks from the row area. Figure 45 shows an example of one such device.



Figure 45: An example of a horizontal disc type row preparation device

5.3 Group 3 – Furrow opening devices

The furrow opener is the specific device that opens the furrow into which the seed is placed. The opener may incorporate or enclose a portion of the seed delivery system and/or the seed boot that facilitates seed placement in the furrow. Their general functional and operational requirements are discussed below.

5.3.1 Functional requirements of furrow openers

The *functional requirements* of a furrow opener are to:

- open a furrow to the required depth (consider depth in relation to seed type, seed size, soil temperature, soil moisture, light requirement, etc);
- maintain uniformity of depth along the length of the furrow and between furrows across the width of the planter (consider uniformity of furrow depth in relation to effects on rate and uniformity of germination, emergence and establishment);
- cause minimum disturbance to the seedbed (consider disturbance in relation to soil moisture loss, the mixing of wet and dry soil in the seed zone, etc);
- firm the base of the seedbed but avoid smearing or over-compaction of the base and walls of the furrow (consider firming in relation to moisture transfer and smearing and excessive compaction in relation to restriction of root growth, etc);
- prevent soil flowing back into the furrow before seed placement (consider the need to place the seed on the moist, undisturbed furrow base to maximise moisture transfer and availability); and
- promote the appropriate degree of soil flow back into the furrow after seed placement (consider the need to close the furrow to obtain good seed/soil contact, stabilise conditions and reduce the likelihood of seed loss by predators).

5.3.2 Operational requirements of furrow openers

To achieve the functional requirements, the *operational requirements* are that a furrow opener should:

- be rigidly held in its working position, although suitably protected from damage by obstructions, to maximise control over both furrow depth and seed placement;
- have provision for vertical adjustment (relative to the soil surface) to enable alteration of planting depth and horizontal adjustment (relative to adjacent openers) to allow alteration of row spacing if required;
- be suitable for the soil type and condition expected at time of planting and capable of operating successfully through the existing surface residues;
- have an effective depth control mechanism to ensure the seed is placed at a consistent depth relative to the soil surface;
- be as narrow as possible in the direction of travel because narrow openers cause less overall disturbance to the seedbed and have a lower draft requirement;
- be easily restrained or held in an effective working position;
- promote soil flow back into the furrow after seed placement; and
- reduce the potential to interfere with the operation of adjacent openers.

There are, however, limitations to the narrowness of openers because very narrow openers:

- are more prone to cause smearing of the furrow base and walls, particularly when they have large rake angles and are used in moist, high clay content soil types;
- may prevent good seed/soil contact by not allowing sufficient soil flow back into the furrow or by reducing the effectiveness of the seedbed firming device; and
- may not have sufficient strength for reliable operation.

5.3.3 Types of furrow opener

Most furrow openers can be broadly classified as ‘runner’, ‘concave disc’, ‘disc coulters’, ‘bioblade’, ‘tine’, ‘punch’ or ‘powered’ (Figure 46) or as derivatives of these types.

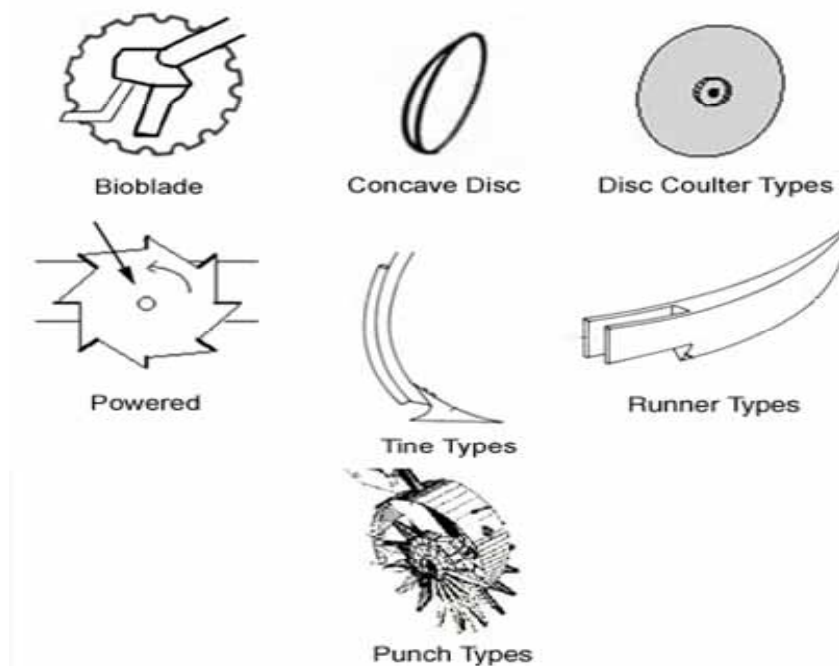

Figure 46: Common types of furrow opening devices

There is considerable design diversity within each type. The general action by which they create a furrow or a hole (into which the seed is placed) differs but can be broadly described as follows:

- runner type furrow openers tend to form a furrow by displacing soil downwards and outwards (i.e. press out a furrow);
- tine type furrow openers tend to open the furrow by displacing soil upwards and outwards on both sides of the furrow (i.e. dig a furrow);
- concave disc type furrow openers tend to open a furrow by cutting and displace soil upwards and outwards to one side of the furrow (i.e. cut and dig a furrow);
- disc coulters type furrow openers either ‘cut’, ‘cut and dig’ or ‘cut and press’ out a furrow depending on the particular type employed;
- punch type furrow openers do not create a furrow but rather ‘punch’ a series in individual holes into which the seed is placed (i.e. punch a hole by pushing small volumes of soil downward and outwards);
- powered type furrow openers tend to cut and till a narrow furrow into which the seed is placed (i.e. cut and till a furrow);

- bioblade type furrow openers tend to create a furrow by cutting and lifting soil; the soil essentially falling back into place after seed placement (i.e. cut and lift).

Quite accurate predictions in relation to the ability of the various types to successfully operate under specific seedbed conditions can be made from a general understanding of the ‘opening action’ deployed. For example, openers that press out a furrow as a result of a negatively raked opener sliding through the soil (e.g. a runner type opener) have little ability to handle less well-prepared seedbeds or seedbeds with a significant level of surface residue. Tine type openers that tend to dig a furrow by way of a positively raked tool moving through the soil could be expected to have excellent penetration ability and handle hard seedbed conditions with ease.

Knowledge of the opener type and action can allow predictions as to the likely shape of the furrow resulting from its use. Typical furrow cross-sections resulting from four opener types are shown in Figures 47 and 48.

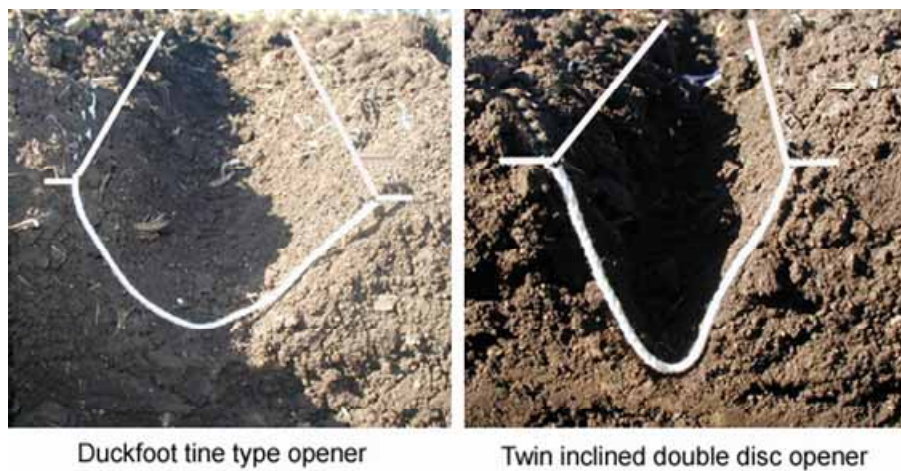

Figure 47: Typical furrow shapes made by a duckfoot and a double disc type furrow openers

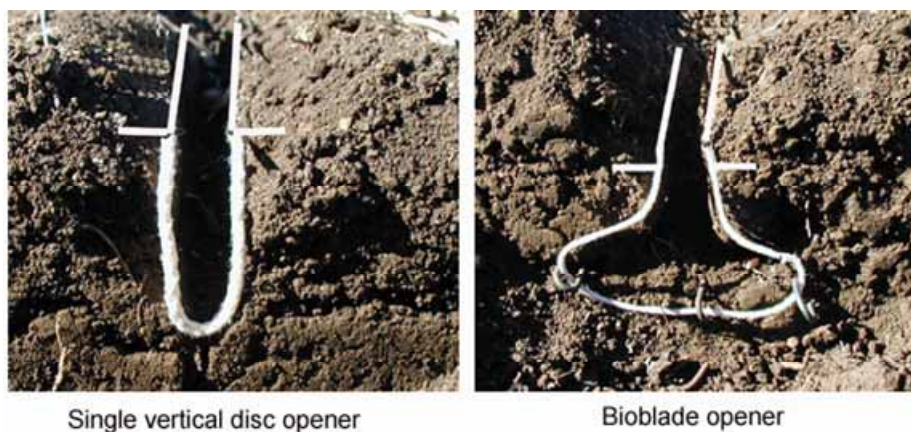

Figure 48: Typical furrow shapes made by single vertical disc and bioblade type furrow openers

The range of commonly available furrow opener types and the relative merits of particular designs within each type are discussed below.

Runner type openers

Runner type furrow openers essentially consist of a blade that gradually widens and then splits towards the rear to form a cavity through which the seeds are dropped (Figure 49).

The front section of the opener is 'V'-shaped (in transverse cross-section) and extends below the wider rear portion. As the opener is drawn forward (in a sliding action) it displaces soil downwards and outwards to form a distinctly 'V'-shaped furrow. The side plates of the wider, split rear portion of the opener helps prevent soil falling back into the furrow before the seed is placed.

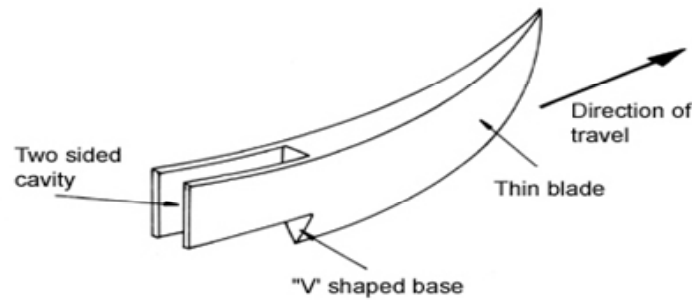

Figure 49: Full runner type opener

In general, runner openers can be classified as full runner types (Figure 49) or stub runner types (Figure 50) on the basis of the rake and included angle of the leading blade section.

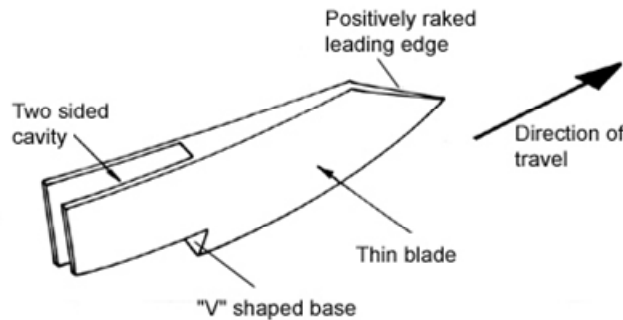

Figure 50: Stub runner type opener

Runner type openers are suited for use where deep, well-prepared seedbeds (i.e. seedbeds with good tilth to a depth below planting depth and free from weeds and residue, etc) have been created in more frictional soil types (i.e. sands to loams). As the runner travels forward, it displaces soil downwards and outwards (increasing both its strength and density) to form a neat, firm-walled furrow of uniform depth. Overall disturbance to the seedbed is slight and the seeds are placed on a firm furrow base.

The performance of runner openers is reduced or unsatisfactory when used in shallow or unprepared seedbeds or in cohesive/adhesive soil types (i.e. soils with high clay content).

In shallow or unprepared seedbeds, it is more difficult to obtain and maintain optimum furrow depth and if depth can be maintained over-compaction of the walls or base of the furrow may result. Runner openers do not operate effectively where surface residues exist unless the residue is short or cut into short lengths by a disc coultter preceding the opener. Uncut residues tend to build up around the leading

edge or are forced down into the furrow, in both cases reducing the operational and/or functional performance of the opener.

Runner openers are generally not suited for use in soils with high clay content. Under wetter soil conditions, the sliding action of the opener tends to cause ‘smearing’ along the base and walls of the furrow to the extent that it can severely restrict subsequent root development. Further, when these soils are in a ‘sticky’ condition, soil tends to adhere to, and build up on, the runner to such an extent that it will not operate satisfactorily.

The actual shape of the runner opener can affect its performance under particular conditions. The draft, vertical restraining force, uniformity in furrow depth and shape, degree of soil disturbance, etc, are all influenced by the rake and included angles of the runner opener. A stub runner (Figure 50) tends to lift surface residue rather than rather than push it into the seedbed as does a full runner (Figure 49).

Runner type openers are best suited for use where deep well-prepared seedbeds (i.e. seedbeds with good tilth to a depth greater than that of planting and free from weeds and residue, etc), are created in the more frictional soil types (i.e. sands to loams). They are ideally suited to, and used commonly in, horticultural cropping systems, particularly vegetable crops.

Over-compaction and/or smearing of the walls of the furrow and soil adhesion to the opener are recognised operational problems associated with the use of runner type openers in moist clay soils. These limitations, together with the runner opener’s inability to operate successfully through high levels of surface residues, severely restrict their use in conservation cropping systems.

Attachments to the runner opener can modify its performance under particular conditions. For example, depth gauges fitted to the sides of the opener can be used to assist in depth control in very soft soil conditions. Combining runner openers with, for example, concave disc or tine type row preparation devices may permit their use in shallow, less well-prepared seedbeds or where there are higher levels of surface residue at planting.

Figures 51 and 52 show examples of the full and stub runner types.



Figure 51: An example of a full runner type furrow opener



Figure 52: An example of a stub runner type furrow opener

While the runner openers shown in Figures 51 and 52 are typical for their respective types, a wide range of shapes and sizes are available. Most manufacturers provide a range of optional opener sizes and types to suit a particular makes and models of planting machine.

Seed placement on runner type openers is generally accomplished in one of two ways: directly dropped through the rear two-sided cavity of the opener from a seed metering unit positioned directly above or protruding into the cavity (Figure 48) or via a short dropper tube that delivers the seed from the meter to the rear cavity in the opener (Figure 53).



Figure 53: Seed delivery via a short dropper tube

The seed falls to, and tends to concentrate in, the bottom of the furrow by virtue of the usually well-formed ‘V’-shaped furrow created by this type of opener. There is no requirement for a specialised placement device; the runner opener performs both the furrow opening and seed placement functions.

Concave disc type openers

Concave disc openers essentially use a single, small-diameter concave disc that is drawn at an angle to the direction of travel to open the furrow into which the seed is placed (Figure 54).

As the disc moves forward, the soil is cut, displaced upwards and deposited to one side of the ‘U’-shaped furrow that results. The angle of the disc to the direction of travel enables a dropper tube, located towards the rear of, and protected by, the disc, to place seed before any significant amount of soil flows back into the furrow.

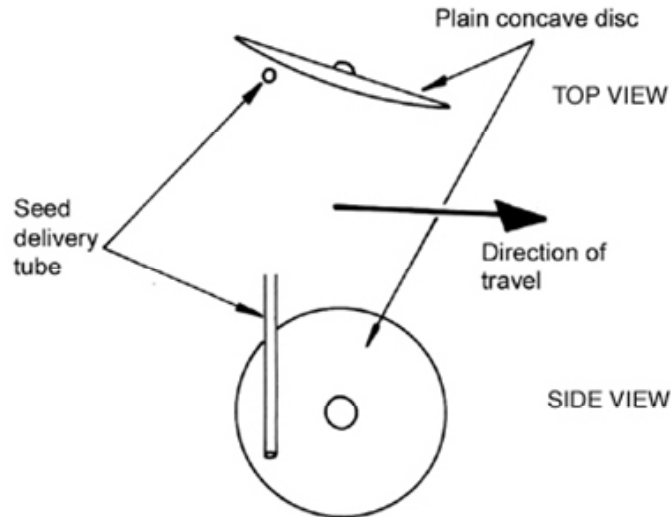

Figure 54: A concave disc type furrow opener

The cutting and digging action of the disc, as it moves forward with a rolling rather than sliding action, permits its use over a wider range of soil and residue types and conditions than the runner type openers.

Disc diameter, disc concavity, disc angle (to both the vertical and direction of travel) and forward speed of operation are the major determinants of the performance of concave disc type openers. Usually, small diameter (250 mm to 300 mm) discs with shallow concavity and fixed angles are used to reduce the cost, weight, penetration-force and seedbed disturbance. As a result, the concave disc opener is more suited for use in well-prepared seedbeds. While the concave disc opener may be used under firm seedbed conditions, the typical disc diameter and vertical restraining force available on machines with this type of opener severely restricts their use in reduced- or no-till situations, particularly when deeper furrows are required or where higher levels of surface residue exist. Figure 55 shows an example of a concave disc type furrow opener.



Figure 55: A single concave disc type furrow opener (rear side view)

Seed placement on single concave disc openers is accomplished via a dropper tube attached to a wedge shaped placement device positioned in close contact to the lower rear portion of the non soil-engaging side of the disc. In essence, this wedge follows in the shadow of the disc and is positioned such that it slightly displaces the disturbed soil and/or the furrow wall laterally and prevents this soil falling back into the furrow until the seed falls to the bottom of the furrow.

While the rear portion of this wedge shaped placement device is shown in Figure 52, its shape is similar to the seed placement devices used on single disc coulters as shown in Figure 61, except that the leading edge is moulded to suit the convex rather than flat profile of the disc.

Disc coulters type openers

Disc coulters type furrow openers utilise flat, rather than concave, discs and are available as single, double and triple disc types (Figure 56).

Although flat, plain and notched disc coulters types can be used independently as a furrow opener, they differ from soil and residue cutting type disc coulters in that they are drawn at an angle to the direction of travel so as to cut and displace soil to form a furrow.

Broadly classified as single, double or triple disc coulters types on the basis of the number of disc coulters used in the design, further classifications within each type can be made on the basis of the particular type and/or configuration of the discs used.

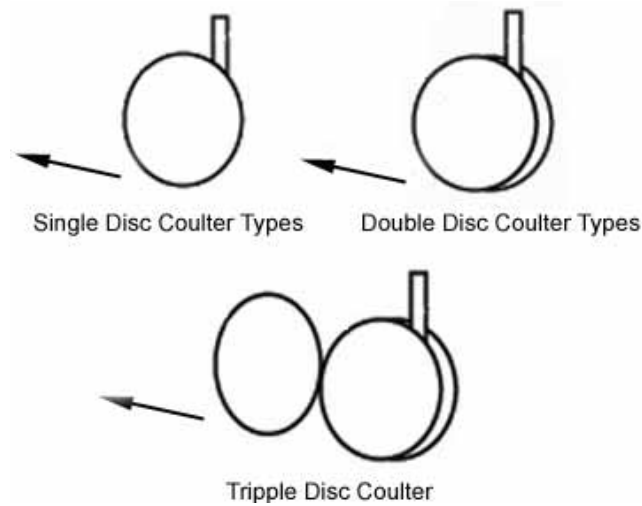

Figure 56: General types of disc coulters furrow openers

Single disc coultter types

Single disc coultter types (Figure 57) generally employ a large diameter (up to 600 mm), plain or, to a lesser extent, notched disc coultter to cut soil and residue and create the furrow into which the seed is placed. Single disc coultter type openers can be classified as aligned, single angle or compound angle types on the basis of the disc's angle to both the vertical (i.e. 'tilt' angle) and to the direction of travel (i.e. 'disc' angle).

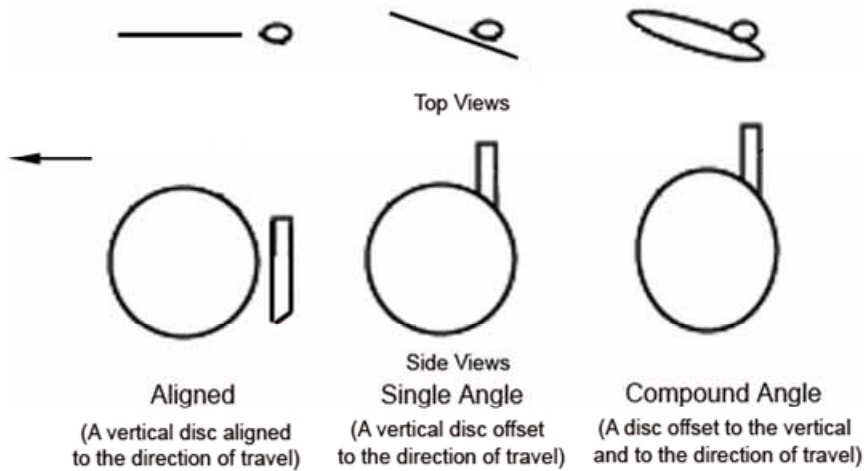

Figure 57: Types of single disc coultter furrow openers

On aligned single disc coultter opener types (Figure 58) the discs are mounted vertically and drawn parallel to the direction of travel (i.e. have neither tilt or disc angles).

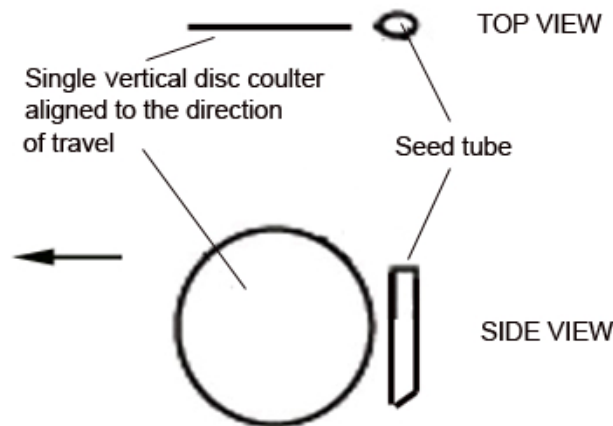

Figure 58: Single, aligned disc coultter opener type

This type of single disc coultter opener simply makes a vertical cut to the depth of seed placement then relies on the following narrow seeding boot to expand the cut to form a furrow into which the seed is placed. With this very simple opener design there is limited scope to make adjustments to suit particular soil conditions. This, together with the dependence on the sliding action of a 'wedge' shaped seeding boot to expand the furrow to effect seed placement, limits opener performance, particularly when operating under both hard soil and moist clay soil conditions.

On single-angle single disc coulters (Figure 59) the discs are mounted vertically (i.e. have no tilt angle) but are drawn at an angle to the direction of travel (i.e. have disc angle). The opener relies on the disc angle to cut and displace soil and/or residue to form the furrow. This type of opener forms a near vertical, narrow, rectangular furrow into which the seed is placed by a dropper tube and seed boot that is located behind the centre, and largely in the shadow, of the disc. Soil tends to be displaced to one side of furrow. For a given soil type and condition, the degree of disturbance and displacement depends largely on the disc size, disc angle, depth setting and speed of operation.

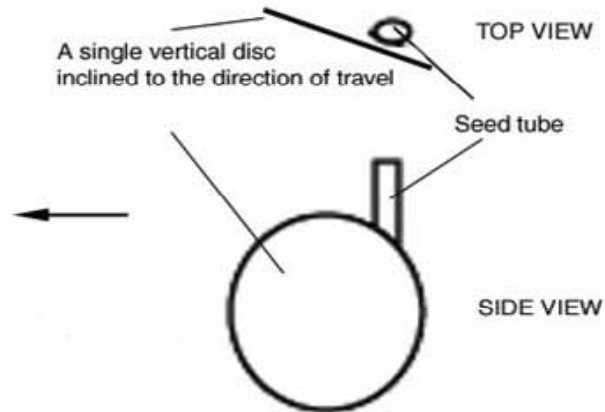

Figure 59: Single-angle single disc coulters type opener

On compound-angle single disc coulters (Figure 60) the discs are mounted so as to have both tilt and disc angles (i.e. the disc is offset to the vertical and drawn at an angle to the direction of travel). These angles alter the furrow opening process such that the soil is cut and lifted rather than cut and displaced. The degree of displacement increases with speed of operation.

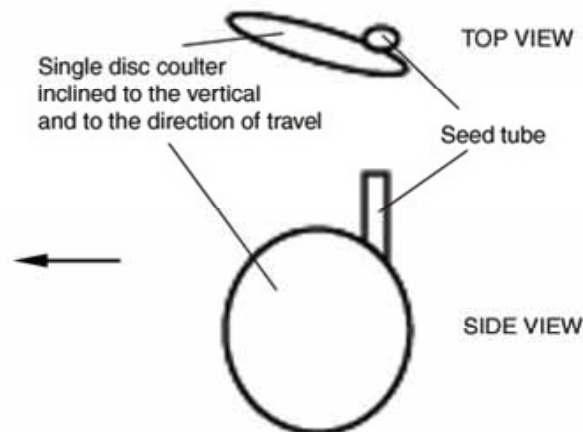

Figure 60: Compound-angle single disc coulters type opener

On both the single and compound angle types, in particular, the position of the depth or gauge wheel is significant. Apart from controlling opener depth, the depth or gauge wheel may be used to:

- assist in reducing soil displacement from the furrow;
- encourage soil flow back into the furrow after seed placement; and
- assist in cleaning the disc when operating in moist soil conditions.

While single disc coulters types have high residue cutting ability under firm soil conditions, the large rake angle can promote 'hair-pinning' of residue in wet or soft soil conditions. With adequate down pressure, large diameter disc coulters have good hard soil penetration ability, particularly in the case of

the compound angle types. The performance of single disc coulters in wet clay soils can be improved by the use of scrapers to clean the disc.

The typical layout of a planter utilising a single aligned disc coulters is shown in Figure 61.

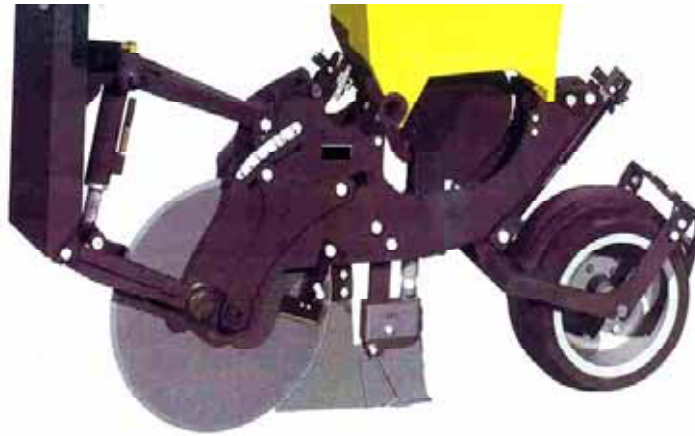

Figure 61: A planter utilising a single aligned disc coulters type opener

Figure 61 shows that the vertical aligned disc coulters is an integral component of the opener, which consists of the disc coulters, a filler plate and the seed placement device. While the disc coulters performs a similar function to those used as a discrete ‘soil and residue cutting device’ its removal would render the opener inoperable under any soil type and condition.

The more detailed views of the aligned single disc coulters opener in Figure 62 show the disc coulters, the filler plate and the seed boot that form part of the opener. The filler plate forms part of the wedge shape that expands the cut to form the furrow and has forward projections that act as scrapers to help clean the disc when operating under moist/sticky soil conditions. The seeding boot encloses the lower portion of the dropper tube and prevents soil movement back into the furrow before seed placement.



Front Side View

Rear Side View

Figure 62: The front-side and rear-side views of an aligned single disc coulters opener

Figure 63 gives the front and the side views of a typical single angle, single disc coultter type of furrow opener. In addition to the furrow opener depth control wheel (i.e. the large wheel), the front and side views show the relative position of two (optional) smaller wheels located forward of the disc centreline and on either side of the vertical disc coultter. The prime function of these wheels is to assist residue cutting. In essence, the wheels hold the residue while it is being cut by the disc. Under softer soil conditions this can improve the cutting action and reduce the potential of the disc to ‘hair-pin’ rather than to cut the residue. The position of the depth or gauge wheel can reduce the degree of soil displacement from the furrow, particularly when the machine is operating at higher forward speeds.



Figure 63: The front and side views of a single-angle disc coultter type furrow opener

Figure 64 shows similar views of a compound angled single disc coultter type furrow opener. In this case, the disc has both tilt and disc angles, i.e. it is angled to both the vertical and the direction of travel. The views also show the fitting of scrapers to assist cleaning of disc, which can be important when working in clay soils with high moisture contents. Again, the position of the depth wheel can limit soil displacement from the furrow.



Figure 64: The front and side views of a single compound angled disc coultter opener

Because of their soil-engaging action, single- and compound-angle disc coultter type openers generate considerable side forces which must be accounted for in the overall design of multi-row machines in particular. The common method of balancing the side forces is to have half the openers on the machine opening the furrow by displacing soil to the left and the other half opening the furrow by displacing soil to the right. There are a number of ways this can be achieved. One is to have all the openers on the left

hand side of the machine opening in one direction and all the openers on the right hand side of the machine opening in the opposite direction as shown on the 4-row planter in Figure 65.



Figure 65: Balancing side forces by having opposed openers on either side of the machine

Another approach is to arrange the individual openers in opposed pairs across the full width of the machine as shown on the 16-row machine in Figure 66.



Figure 66: Openers arranged in opposed pairs across the full width of the machine

In Figures 65 and 66 each row unit (i.e. opener and press wheel combination) is mounted independently on a spring-loaded trailing arm pivotally attached to the machine's mainframe toolbar. Another method of balancing the side forces generated by single and compound angle disc coulters openers is to mount them in opposed pairs on a common arm (Figure 67).



Figure 67: Opposed single compound angle disc coulters mounted on a common arm

The particular design shown in Figure 68 has been developed for twin row planting in frictional soils. Both discs share a common press/depth wheel, the operation of which is shown in Figure 67.



Figure 68: Opposed single disc coulters sharing a common press wheel

Single disc coulters have increased in popularity for use in conservation cropping systems over recent years, largely because the single disc coulters' soil penetration and residue cutting ability enables effective operation over a wide range of soil types and residue conditions without the need for a separate soil and residue cutting device (i.e. an additional vertical disc coulters positioned in front of the opener). Seed placement on vertical or compound single disc coulters is accomplished via a dropper tube attached to a wedge shaped placement device similar in position and action to that described for single concave disc type openers. Figure 69 shows a typical seed placement device attached to a single angle disc coulters type opener. In this case, the seed delivery tube is positioned behind the distinctly separate and replaceable, fixed wedge-shaped placement device.



Figure 69: A typical seed placement device for use with single disc coulters type openers

Figure 70 shows a similar view of a single angle disc coultter type opener where the fixed wedge shaped seed placement device has been replaced by a small rotary disc that protects the dropper tube and prevents soil movement back into the furrow before seed placement.



Figure 70: A rotary disc type seed placement device on a single-angle disc coultter opener

Double disc coultter type

Double disc coultter type openers usually consist of two plain, flat disc coultters arranged so that the lower leading edges of the discs touch to cut and displace soil (Figure 71). As the discs roll forward, they cut residue and soil, and displace soil downwards and outwards to form a ‘V’-shaped furrow. The seed delivery tube is fully enclosed by the discs and enables seed to be deposited into the furrow at a position slightly ahead of the point where the trailing edges of the discs leave the soil.

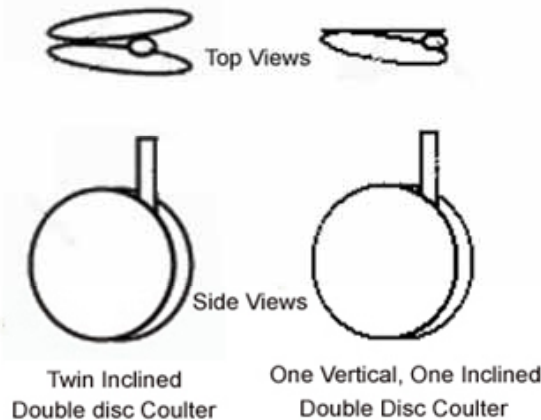

Figure 71: ‘Twin inclined’ and ‘vertical and inclined’ double disc coultter types

Double disc coultter types can be further classified on the basis of disc sizes, angles and alignment. Double disc coultter types can be classified as ‘twin inclined’ or ‘vertical and inclined’ (Figure 71).

The twin inclined disc types are symmetrical; both discs incline uniformly to the vertical as well as to the direction of travel. In the case of the vertical and inclined disc types, one disc is vertical and parallel to the direction of travel, the other inclines in both directions.

In both types, the leading edges of the two discs can be either aligned or staggered. This is sometimes achieved by using discs of different diameters. The four general design options for double disc coultter types are shown in Figures 72 and 73.

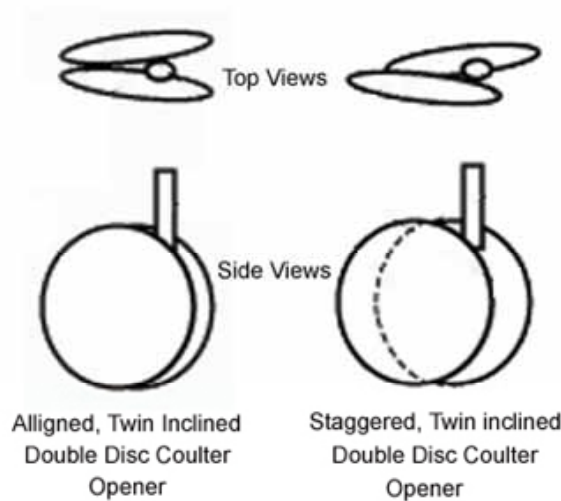

Figure 72: Design options within twin inclined types of double disc opener

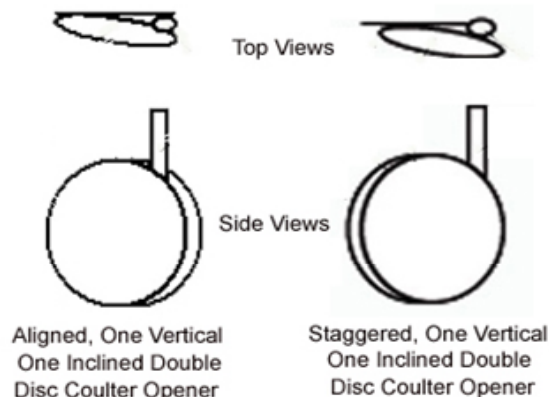

Figure 73: Design options within one-vertical one-inclined types of double disc opener

The action of the double disc coulter type openers is similar to that of runner type openers in that they press out a neat furrow with little overall disturbance. Nevertheless, the rolling and cutting action of the double discs provides better penetration and residue-handling ability. They can operate over a wider range of soil types and conditions because their rolling action assists residue cutting and causes less smearing of the base and walls of the furrow, particularly in more cohesive soil types. Three or more disc scrapers may be required to reduce the soil build-up on the discs when these openers are operating in adhesive soils with high clay contents. Over-compaction of the base and walls of the furrow can result if the double disc opener is used in shallow or unprepared seedbeds. In soft seedbed conditions, residue cutting/handling ability may be inadequate and hair-pinning of residues in the furrow may result. Staggered discs, particularly on the one-vertical and one-inclined types, are considered to have better residue cutting ability and require less vertical force for penetration. Staggering or inclining one disc complicates the design, so if the option for fitting a dedicated soil and residue cutting device is available, the aligned twin inclined double disc coulter type is perhaps the better choice. This provides the benefits of symmetry and less disturbance in well-prepared, moderate residue seedbeds. Its poorer penetration and residue-handling ability is well compensated for by the addition of the soil and residue cutting device in less well-prepared seedbeds with or without high levels of surface residue.

Where the option of fitting a dedicated soil and residue cutting device does not exist, the range of conditions over which double disc coulters can be used may be extended by the use of designs other than the aligned twin inclined types. A staggered, one vertical-one inclined double disc coulter opener

incorporating using a notched disc as the leading disc would confer the greatest residue-handling ability on double disc opener types used without soil and residue cutting devices.

Examples of the lower front views of aligned 'twin inclined' and 'one vertical-one inclined' types of double disc coulters are shown in Figure 74.



Figure 74: Aligned 'twin inclined' and 'one vertical-one inclined' types of double disc opener

Figure 75 shows examples of staggered 'twin inclined' and staggered 'one vertical-one inclined' double disc coulters.



Figure 75: Staggered 'twin inclined' and 'one vertical-one inclined' types of double disc opener

Figure 76 shows the front and side view of a staggered twin inclined disc coulters incorporating a notched and a plain disc coulters.



Figure 76: A staggered twin inclined double disc coulters with a notched leading coulters

Seed placement on double disc coulters type openers does not require the use of any specialised placement device in addition to the seed delivery tube, as the action of the discs opens and holds the furrow open until seed placement occurs. Nevertheless, dropper tube design plays an important part in the seed placement process.

Where seeds exit from a short dropper tube that terminates some distance from the furrow base (Figure 77), seeds may be distributed over a wider band and not necessarily confined to the base of the furrow. A well-designed dropper tube that extends almost to the base of the furrow provides more uniform placement. Research indicates that if such dropper tubes terminate with a rearward deflection (Figure 78), both seed placement and seed spacing (where appropriate) can be improved.



Figure 77: Seed placement via a dropper tube terminating well above the furrow base

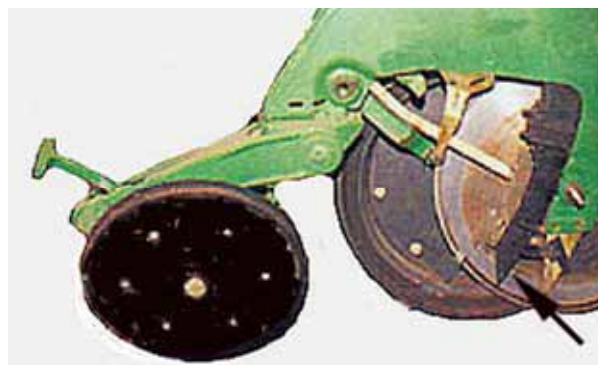

Figure 78: Seed placement via a dropper tube terminating near the furrow base

Triple disc couler types

Triple disc couler opener types have a plain, flat vertical disc couler mounted close to, and in front of, a twin inclined double disc couler assembly (Figure 79). In design, it approximates that of a twin inclined double disc couler opener used in conjunction with a disc couler type dedicated soil and residue cutting device. The leading disc makes a vertical cut in the soil and the double discs form the 'V'-shaped furrow by displacing the soil downward and outward. The leading disc assists in cutting crop residues and the resulting vertical cut tends to give more control over subsequent soil fracture. Using a flat plain leading disc couler may result in a more uniform and less disturbed furrow; using a wavy leading disc couler increases soil disturbance and tends to result in a wider furrow shape.

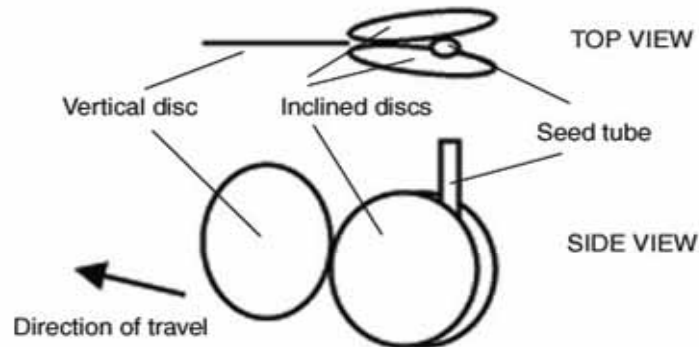

Figure 79: The layout of a triple disc couler type furrow opener

Figure 80 shows a rear side view of a triple disc couler opener. The smaller-diameter leading disc is typical of earlier designs and limits residue-handling ability. More recently, the dedicated triple disc couler type has been largely replaced by a combination of a twin inclined double disc couler opener and a separate disc couler soil and residue cutting device. This combination provides greater flexibility in the type, diameter and setting of the leading disc compared to the discrete triple disc couler unit.



Figure 80: A rear view of a dedicated triple disc couler type furrow opener

Seed placement on triple disc couler type openers is achieved in the same way to that on double disc couler types, as previously discussed.

Tine type openers

A wide range of tine type openers is used and an even wider range of names is used for particular shapes/designs within this broad grouping. In general, tine openers have rake angles (i.e. the angle made between the leading edge of the opener and the direction of travel) of less than 90 degrees. Tine type openers tend to ‘dig’ a furrow by penetrating the soil and displacing soil upward and outward to form a ‘U’ or ‘V’-shaped furrow. Under high surface residue conditions tine type openers need to be preceded by a soil and residue cutting device to cut the surface residue.

Tine openers can be broadly classified as ‘dedicated’ or ‘dual purpose’. In general terms, dedicated tine types are relatively narrow and have been specifically designed for use on planting equipment. Dual purpose types are generally wider and include those that have been selected from the range of tine type ground tools traditionally used on both tillage and planting equipment. Figure 81 gives some typical examples of types within both categories. They are discussed below.

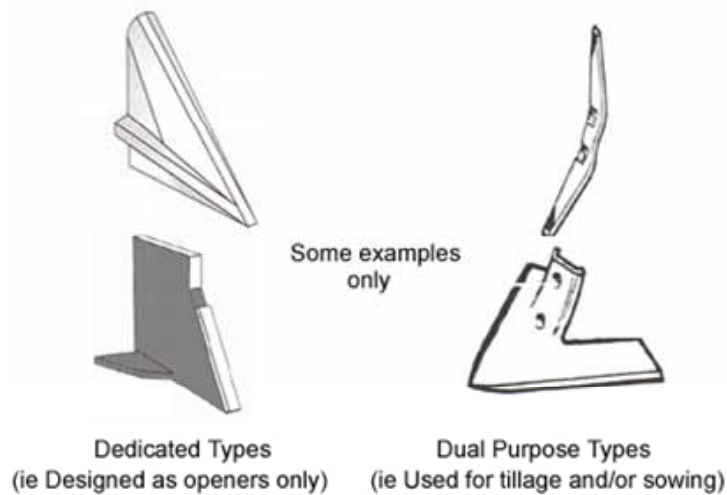

Figure 81: The two general types of tine type of furrow opener

Dedicated tine type furrow openers

Dedicated tine type openers are those developed specifically for use as furrow openers and can be broadly classified as either ‘point’, ‘knife’, ‘inverted T’ or ‘shoe’ types (Figure 82).

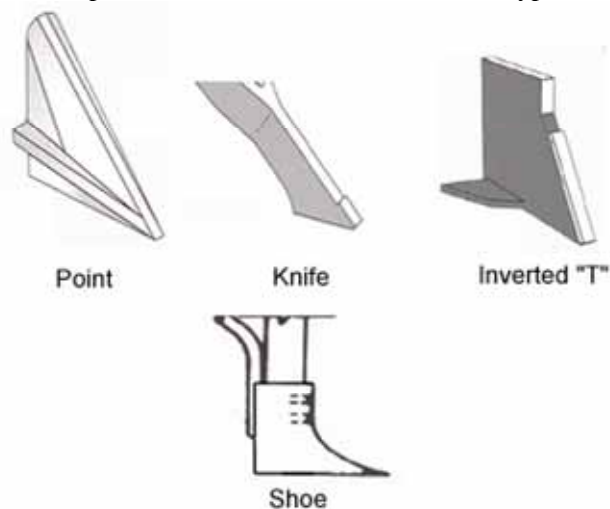

Figure 82: The general types of dedicated tine type furrow openers

Figure 83 shows the general form of point type furrow openers. Typically, they have a low rake angle (less than 40 degrees), a narrow leading edge and a pointed tip.

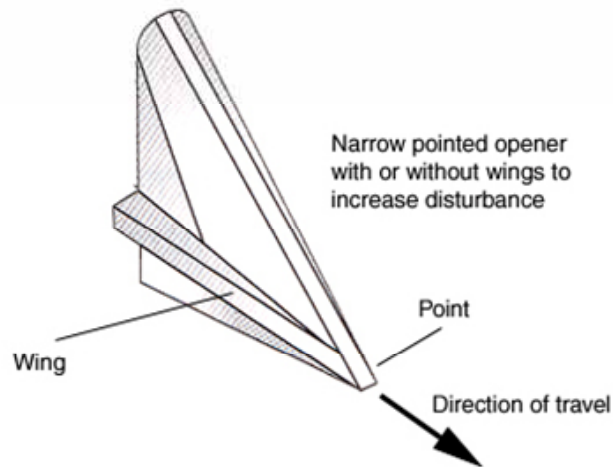

Figure 83: the general form of point type tine openers

The leading edge of point type openers may be flat, rounded or 'V'-shaped and the body of the point may have small wing extensions to help lift soil to create the furrow or otherwise disturb the soil to improve seed/soil contact. The point has heel clearance to assist with penetration and avoid compacting or smearing the furrow base. Point type openers perform successfully over a wide range of soil types and seedbed conditions but they are ideally suited for use in heavier clay soils and where there is no requirement for seedbed disturbance below the depth of seed placement. A significant advantage in using point type openers is that they are relatively inexpensive, there is a wide range of specific designs available, many are interchangeable with or without the use of adaptors and some individual points can be inverted to allow a change in rake angle, the degree of disturbance, etc.

All three types shown in Figures 84 and 85 are interchangeable via the use of a standard adaptor. Figure 84 shows two examples of point type openers. The wingless version is designed symmetrically, enabling it to be inverted when worn to extend its useful working life. The winged version is simply an adaptation of the same basic shape; one of many variations in the design available to facilitate point selection for particular conditions.



Figure 84: Winged and wingless versions of the same basic opener shape

Figure 85 shows a winged point mounted in both positions enabled by reversing (inverting) the point. The change in wing position resulting from inverting the point provides for a degree of flexibility in the nature and the extent of seedbed disturbance resulting from its use. In the ‘wings up’ position the opener creates significantly more disturbance to the seedbed.

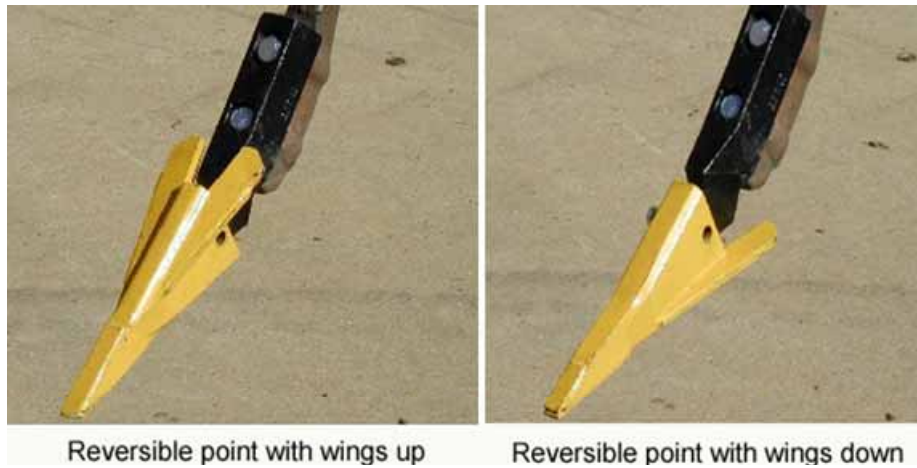

Figure 85: An example of a reversible point type opener

Knife points have the general form depicted in Figure 86. They are essentially a blade with a narrow cross-section, normal to the direction of travel, and a relatively large rake angle (60–70 degrees). Knife points create a narrow furrow by displacing soil sideways because of the low critical depth resulting from the narrow cross-section and high rake angle.

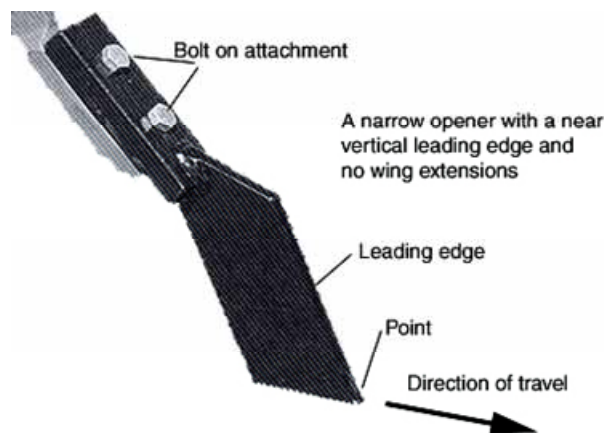

Figure 86: The general form of knife type tine openers

Knife points are ideally suited for use in well-structured loam or sandy loam soils where a narrow furrow is produced with minimum disturbance and smearing. The knife opener is not suited for use in heavier clay soil types, particularly at higher moisture content, because of the resulting compaction and smearing of the base and walls of the furrow. The knife is ideally suited to applications where soil disturbance below the seed placement depth is required provided the soil type and seedbed conditions permit its effective use. A wide range of often interchangeable designs is available and a typical example is shown in Figure 87.



Figure 87: A typical knife type tine opener

Inverted 'T' type tine openers are essentially winged knife type openers; Figure 88 shows their general form. The position of the wings varies depending on the particular design. The wings may be restricted to the lower portion of the blade section or be placed further up the trailing edge.

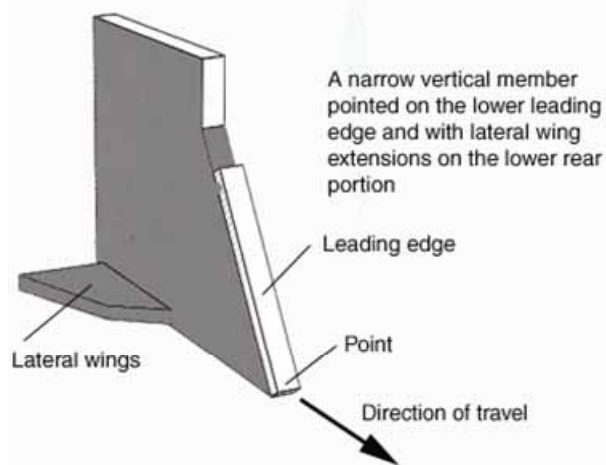

Figure 88: The general form of inverted 'T' type tine openers

Essentially, the wings tend to create disturbance within the seed zone while keeping surface disturbance to a minimum. This action enables the inverted 'T' types to successfully operate over a wider range of soil types and conditions than the knife types. Nevertheless, the action of the inverted 'T' type makes it unsuited for use in moist clay soils where smearing and soil adhesion to the opener compromises performance. The concept for the bioblade type furrow opener was largely derived from work undertaken to develop and refine the action of the inverted 'T' type opener. Figure 89 shows the front and side views of a typical inverted 'T' type tine opener.



Figure 89: Front and side views of a typical inverted 'T' type dedicated tine opener

Shoe type tine openers are taken here to include a wide range of tine mounted dedicated furrow openers that can have a near vertical, forward or rearward curved leading edge with side plates that enclose the seed delivery system or otherwise assist in preventing soil movement back into the furrow before seed placement. Figure 90 shows the general forms of this type.

Shoe type openers have been developed essentially for use in conventional, well-prepared seedbeds without significant amounts of surface residue. Given this, the diversity of furrow opening actions resulting from the various forms and their general inapplicability in modern conservation cropping systems they are not further discussed here. Typical examples of all three general forms as described are shown in Figure 91.

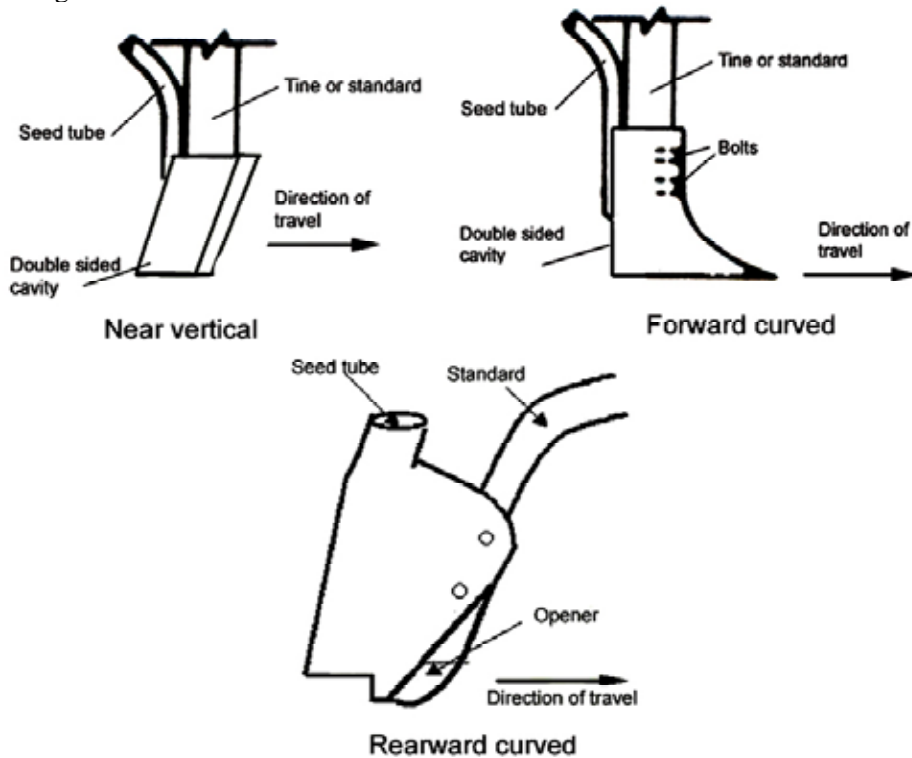

Figure 90: General form of near vertical and forward and rearward curved shoe type tine openers

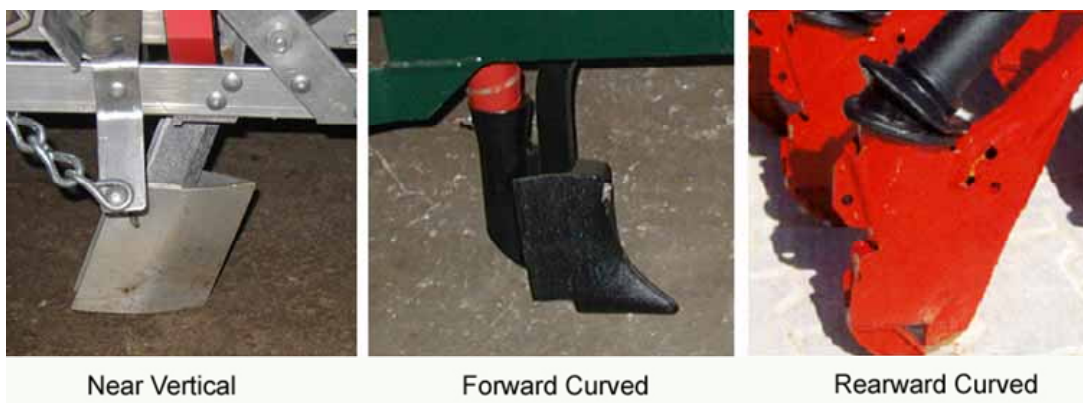

Figure 91: Typical examples of near vertical, forward curved and rearward curved shoe type tine openers

Dual-purpose tine type furrow openers

Dual-purpose tine type openers are essentially secondary tillage tools that have been selected to open furrows for seed placement. The three general forms of dual-purpose tine type furrow openers are 'points', 'sweeps' and 'duckfoot' (Figure 92).

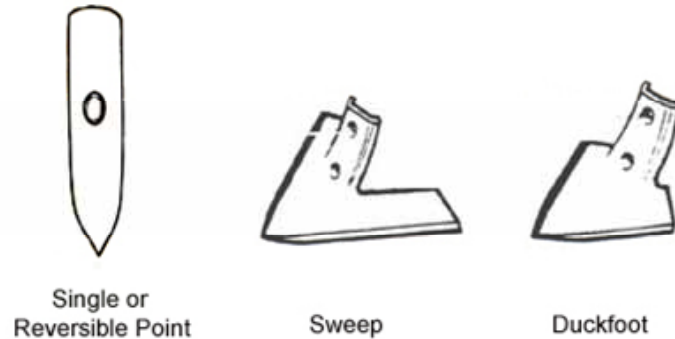

Figure 92: The general types of dual-purpose tine type furrow openers

Dual-purpose point type openers differ from dedicated point types in that the leading edge of the dual-purpose point is typically curved rather than straight and is flatter, wider and steeper than the leading edge of the dedicated point. They can be single or reversible and are generally considered inferior in their furrow opening action to dedicated point types. In general, their furrowing opening action is less controlled and gives more seedbed disturbance than their dedicated counterparts, particularly in firm to hard seedbed conditions where soil tends to be shattered rather than cut or parted.

Duckfoot and sweep type furrow openers are essentially tools designed for secondary tillage; principally cultivation for weed control. They can be described as spade-shaped, 'V'-pointed tools, but the sweep is wider by virtue of the wing extensions to both sides of the main body portion of the tool. While both can be used as a dedicated, high disturbance, furrow opener their use is primarily reserved for situations where there is a need to open a furrow and simultaneously cultivate for weed control. This compromise between tillage and furrow opening action results in a high degree of soil disturbance with an increased potential for soil moisture loss from the seedbed. Nevertheless, the endless variety of shapes and widths available does allow the use of dual purpose openers in more friable seedbed conditions where soil flow over the opener provides for adequate soil covering after seed placement. The overall action can be improved by attempting to separate the cultivation and furrow opening functions by welding a narrow cutting component to the underside of the leading 'V' point. This is often achieved by using a pointed 25 mm square section tip to cut a seed furrow in the firm soil below the interface between the tilled and non-tilled layer (see Figure 2 and related discussion).

Typical point (reversible), duckfoot and sweep opener types are shown in Figure 93.

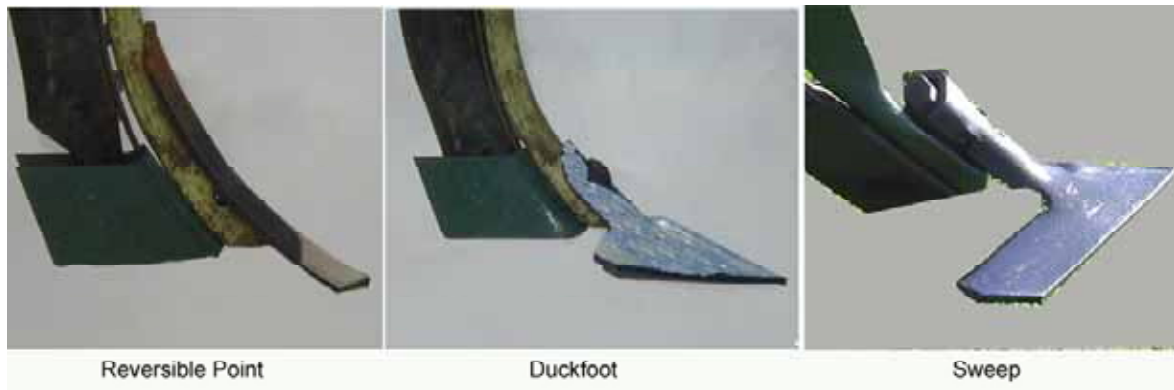

Figure 93: Typical point, duckfoot and sweep type, dual purpose tine type furrow openers

A wide diversity of seed placement devices is used with tine type openers. While they vary in complexity, most consist of a dropper tube delivering the seed via a placement device attached to the lower rear portion of the tine, standard or shank that supports the furrow opener. In most cases, the function of the device is to prevent soil movement back into the furrow before seed placement occurs.

In the case of dual purpose tine type openers (i.e. wide points, duckfoot and sweep types) the placement device is usually a very simple 'U'-shaped piece of metal attached to the rear of the tine through which the seed drops to the furrow. These placement devices (Figure 93) follow in the shadow of the opener and/or tine.

On dedicated tine openers, the placement device used for shoe types is often incorporated into the opener design (Figure 91), where the side plates that prevent soil movement back into the furrow are fully or partly formed by extensions protruding rearwards from the main body of the opener. This is also illustrated in Figure 94 where the rearward curved shoe opener is attached to and fully enclosed by the combined seed delivery and support system.



Figure 94: Rearward curved shoe type opener and seed placement device

On dedicated tine openers, the placement device for the narrow point, knife and inverted ‘T’ type openers is usually more sophisticated, often with provision for vertical, sideways and rearward adjustment (relative to the opener) to suit particular opener types, soil types and soil conditions. Figure 95 shows a fixed seed and fertiliser placement system attached behind an inverted ‘T’ type opener and an adjustable version of the same type mounted behind a narrow point type opener.



Figure 95: Fixed and adjustable seed and fertiliser placement systems for tine type opener

The bioblade opener

The Agrisystems™ cross-slot opener or bioblade furrow opener is one of the more recent developments in opener design. In essence, it combines the attributes of a soil and residue cutting disc coultter with an inverted ‘T’ type opener. Conceptually, at least, the bioblade opener was formed by splitting the inverted ‘T’ type opener lengthwise and positioning the front edges of each portion of the split opener so they rubbed on each side of a flat, notched disc coultter. As the opener (Figure 96) is drawn through the soil the disc coultter cuts residue and makes a vertical slot deeper than the intended depth of planting. The vertically adjustable, winged Bio-Blades™ make a horizontal ‘cross-slot’ at the required level below the surface into which the seed and fertiliser fall on opposite sides of the disc.

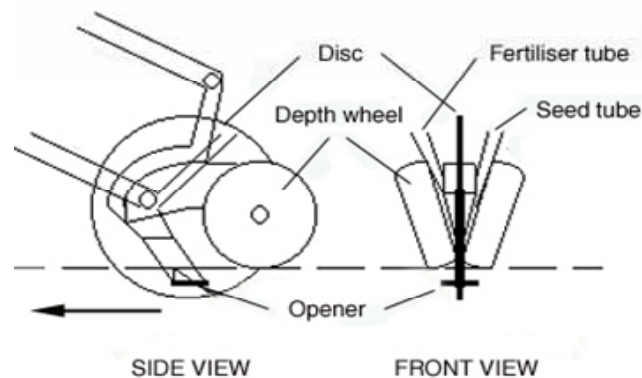

Figure 96: Diagrammatic representation of the bioblade type furrow opener

The low surface disturbance, combined residue/soil cutting and furrow opening capability, and ability to separate seed and fertiliser are key attributes of this opener type. It has shown good capability over a wide range of types and conditions, but requires significant vertical force to ensure penetration in hard soil conditions. Excessive soil cover when planting to depth and the potential to leave loose disturbed soil below the seeding depth, particularly under moist clay soil conditions, may limit performance. This – together with its high cost, complexity and wear rate – has restricted the adoption of this opener type.

Figure 97 shows front, side and rear views of the bioblade type opener. Seed placement is via a dropper feeding seed directly into the space that forms in the shadow of the ‘winged bioblades’ that not only open the furrow but also prevent soil flow back into the furrow before seed placement.



Figure 97: Front, rear and side views of the bioblade type furrow opener

Powered opener types

Powered openers were developed in the 1970s in an effort to combine herbicide application and tillage and planting requirements into a single pass operation for pasture renovation. Essentially, these openers employ a powered cutting wheel or disc to cut crop residues and produce a narrow, well-defined, non-compacted furrow of loose soil into which the seed is placed. Figure 98 gives a diagrammatic representation of the powered type opener.

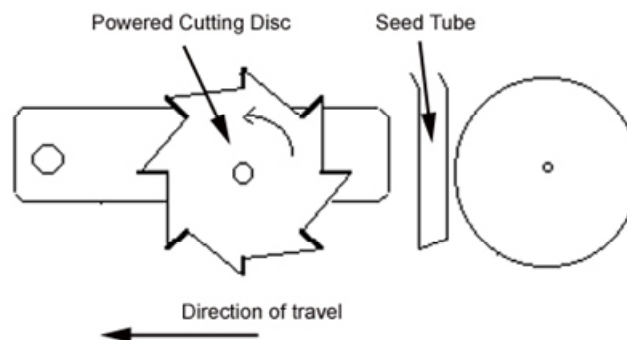

Figure 98: A diagrammatic representation of a powered type furrow opener

Seed placement into the pre-tilled furrow can be achieved directly or indirectly. Direct placement results from the appropriate positioning of the seed delivery tube (Figure 98). Indirect placement occurs when a conventional opener is used directly behind the cutting disc. In this configuration the cutting disc performs a role akin to that of a disc coultter.

Powered openers have demonstrated exceptional ability to operate over a wide range of soil types and conditions, but they have high capital and operating costs compared to most other opener types. This – together with improvements in the performance of other opener designs – has restricted adoption or further development of this opener type. Figure 99 shows a rear side view of a commercially available powered type furrow opener.



Figure 99: The rear side view of a powered type furrow opener

Punch type openers

Punch type openers do not create a furrow in which the seed is placed but rather push or dibble a series of holes into the soil into which one or more seeds are placed. While the concept of using punched or dibbled holes for seed placement has been extensively used in some conventional (particularly horticultural) cropping systems, several units have been developed for use in conservation cropping systems over more recent years.

Most units use a seed meter and an accumulator unit into which the seeds are deposited before being transferred to the ‘punch’ opener for direct deposition into the soil.

While most units use multiple punch openers mounted around a cylinder some have had single vertically reciprocating punch to effect seed placement along the row.

Examples include the single row unit developed in Africa for direct planting through crop residues (Figure 100) and a multi-row unit developed in China to plant through plastic mulch (Figure 101).

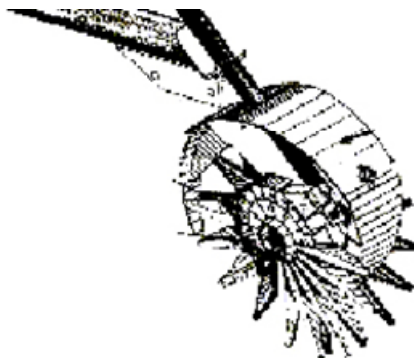

Figure 100: A punch type furrow opener for planting through residue



Figure 101: A punch type opener for planting through plastic mulch

5.4 Group 4 – Seed firming devices

Seed firming devices are designed to press uncovered seed into the soil at the base of the seed furrow to improve seed/soil contact. While seed firming devices are commonly incorporated in the design of specialised horticultural planting machines using a runner type furrow, their use in other applications has been largely confined to machines using a double disc coulter type furrow opener.

5.4.1 Functional requirements of seed firming devices

Where used, the *functional requirements* of a seed-firming device are to:

- firm uncovered seed into the moist soil at the base of the furrow to improve the prospects of rapid moisture transfer to the seed; and/or
- assist seed placement in the base of the furrow by reducing the possibility for seed bounce after initial contact with the soil.

5.4.2 Operational requirements of seed firming devices

To achieve their functional requirements the *operational requirements* of seed firming devices include:

- correctly matching the seed firming device to the width and shape of the furrow to ensure it ‘runs’ on the base of the furrow;
- positioning the seed firming device relative to the furrow opener/seed placement device to ensure it firms the seed on the base of the furrow before any seed covering (i.e. by soil falling back into the furrow) occurs;
- ensuring that (when in use) the device does not interfere with seed spacing requirements by ‘picking up’ or ‘dragging’ seed, particularly when operating under moist clay soil conditions where seed and/or soil may adhere to the device;
- making provision to easily remove or otherwise take the seed firming device out of service when not required or when seedbed conditions are unsuitable for its effective use.

It is the operational requirement that ‘the seed be firmed prior to any soil falling back into the furrow and covering the seed’ that has largely confined the use of seed firming devices to applications where ‘runner’ and ‘double disc coulter’ types of furrow openers are used.

5.4.3 Types of seed firming devices

Most seed firming devices press the seed into the base of the furrow with either a ‘rolling’ or a ‘sliding’ action and can be broadly classified as either ‘seed firming wheels’ or ‘seed firming slides’ (Figure 102).

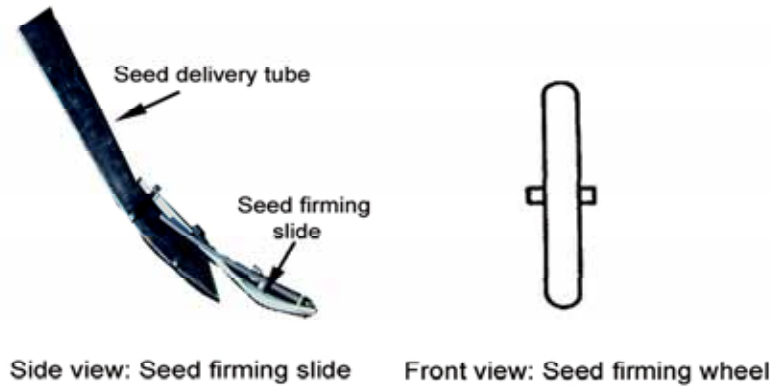

Figure 102: General types of seed firming devices

Seed firming wheels

Seed firming wheels are comparatively small in both width and diameter and firm the seed by a rolling action. Their use is largely confined to applications where they are fitted close to the rear side plates of a runner type furrow opener to restrict soil flow back over the seed before firming takes place. In most cases, the wheels are mounted on a pivoted trailing arm (Figure 103). This arrangement enables the wheel to be lifted vertically and restrained, rather than having to be removed, when not in use. While suitable for use over a wide range of soil moisture conditions in frictional soil types (sands and loams), the wheel’s tendency to pick up both seed and soil under moist, cohesive soil (clay) conditions often restricts their use.



Figure 103: A seed-firming wheel following a runner type furrow opener

Seed firming slides

Seed firming slides firm the seed by way of a 'sliding' rather than 'rolling' action and are generally directly fitted to the rear lower portion of the seed dropper tube used in conjunction with a double disc coulter type furrow opener (Figure 104). In this application, the disc coulters enclosing the dropper tube and slide prevent soil movement back over the seed before firming is effected.

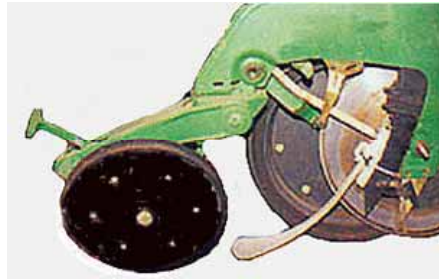

Figure 104: A slide type seed firming device fitted to the dropper tube

5.5 Group 5 – Seed covering devices

Seed covering devices are specifically designed to promote soil flow back into the furrow to cover the seed after placement and/or firming. They play an important role in promoting and stabilising conditions conducive to rapid seed germination and influencing seed emergence and establishment through the manipulation of the depth of soil cover over the seed.

5.5.1 Functional requirements of seed covering devices

The *functional requirements* of seed covering devices are to:

- assist in the transfer of displaced surface soil back into the furrow for the purpose of covering the seed with soil;
- assist in regulating the depth of soil cover over the seed (i.e. assist in regulating planting depth relative to the final seedbed surface); and
- in some cases, assist in re-levelling the seedbed surface.

Covering the seed with soil helps:

- provide and stabilise an appropriate seed environment (e.g. reduce the rate of moisture loss and provide seed/soil contact to optimise both the rate of moisture transfer and the duration of moisture availability to the seed, reduce temperature fluctuations, etc); and
- protect seed from predators such as birds, mice and insects.

5.5.2 Operational requirements of seed covering devices

To achieve the functional requirements, the *operational requirements* of seed covering devices include that:

- they can be selected and/or adjusted to enable them to operate effectively over the range of field conditions likely to exist at time of seeding;
- the depth of soil cover is uniform and appropriate for the species sown;
- seeds in the furrow are not displaced during the covering process;
- the soil covering the seed is left in a condition that does not impede shoot emergence; and
- the devices are compatible with the range of anticipated row spacings.

The need for, and the design of, the covering device on a planter depends on many factors, including:

- the soil type and condition;
- the design of the furrow opener;
- the type and amount of surface residue; and
- the speed of operation, etc.

Not all planters have or need dedicated seed covering devices. Some drill seeders, for example, rely solely on soil flow around the opener to cover the seed. In general, the success of this approach requires:

- a well-prepared seedbed – increasing soil ‘tilth’ and ‘friability’ usually improves the potential for soil to flow around the opener and back into the furrow after the seed is placed
- a narrow furrow opener operating at an appropriate forward speed.

In general, the narrower the opener and the slower the forward speed, the greater the potential for soil flow back into the furrow. Wide openers operating at high forward speeds tend to increase the sideways displacement of soil and hence reduce the potential for soil flow back into the furrow. The interaction of

adjacent furrow openers and/or cultivating tines may affect the depth/uniformity of soil cover over the seed, particularly if wide openers are used on narrow row spacings. Soil displaced by one opener may be thrown in such a way that it adds to the cover over the adjacent seeded row. In conservation cropping systems where narrow openers are used, a seedbed-firming device may be used to perform both the covering and the firming functions.

5.5.3 Types of seed covering devices

The wide range of dedicated (i.e. row specific, rather than non row specific types) seed covering devices can be generally classified as ‘chain’, ‘concave disc’, ‘finger’, ‘knife’, ‘paddle’, ‘tine’, ‘disc coultter’ or ‘finger wheel’ (Figure 105).

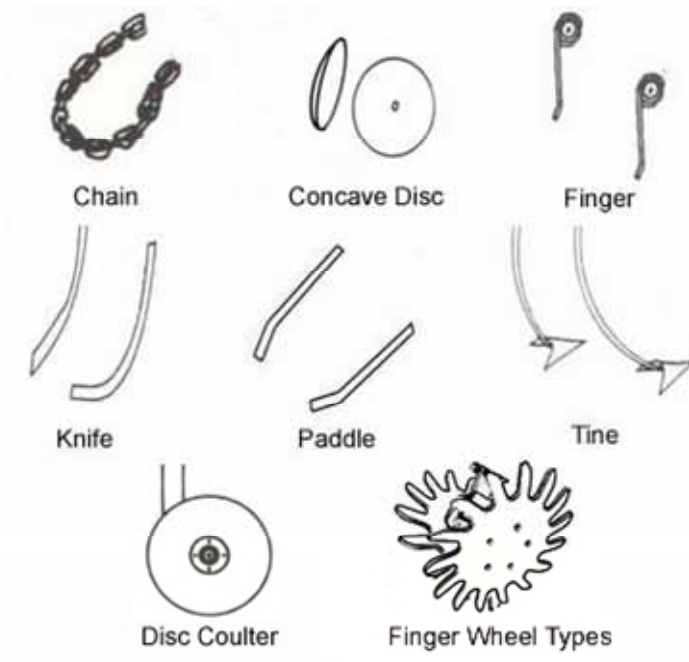

Figure 105: General types of dedicated soil covering devices

Chain type covering devices

Chain type covering devices are designed to trail behind the furrow opener and essentially drag loose soil into the furrow to cover the seed. The resulting effect depends on many factors, including the size, length and mass of the chain, and the method of attachment. For example, the chain may be looped, used in combination with a bar or simply trailed (Figure 106).

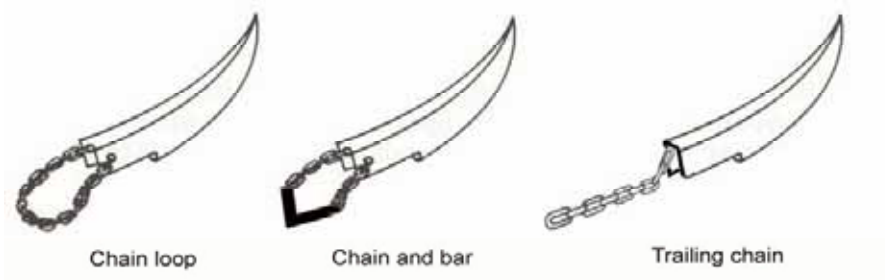

Figure 106: Options for using a chain as a seed covering device

Chain type covering devices are most easily adapted for use in well-prepared (friable) seedbeds without significant quantities of surface residue and where no significant degree of soil movement is required to fill the furrow. Figure 107 shows the chain and bar configuration attached behind a point type furrow opener and a looped chain configuration attached behind a shoe type furrow opener.



Figure 107: Examples of chain-and-bar and looped chain type covering device

Concave disc type covering devices

As seed-covering devices, concave discs can be mounted singularly or in opposed pairs behind a furrow opener to move soil back into the furrow to cover seed (Figure 108).

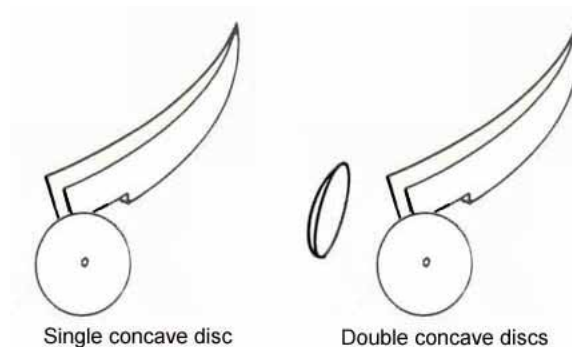

Figure 108: Single and double concave disc type covering devices

The double concave disc option is more generally used and is ideally suited when a significant amount of soil is to be moved to adequately cover the seed.

The ability to adjust the discs horizontally and vertically and to change the angle of the disc in relation to the direction of travel provides for flexibility in use and adjustment.

Figure 109 shows a rear view of a large diameter, double concave disc covering device used to fill and hill soil over the row when planting potatoes using a very wide runner type opener preceded by a double disc coulter type row preparation device (not shown).

While the cutting action of the concave disc type covering devices allow them to operate effectively under conditions where there's a significant amount of crop residue on the soil surface, a degree of residue incorporation into the furrow occurs.



Figure 109: Rear view of a double concave disc type covering device

Disc coulters type covering devices

Disc coulters can be mounted singly or in opposed pairs (double disc coulters) behind a furrow opener to move soil back into the furrow to cover seed (Figure 110).

The double disc coulters option is more generally used and is ideally suited to reduced or zero tillage planting situations where their residue cutting and soil displacement function is used to effectively move soil back over the furrow to cover the seed. The disc coulters can be aligned or staggered.

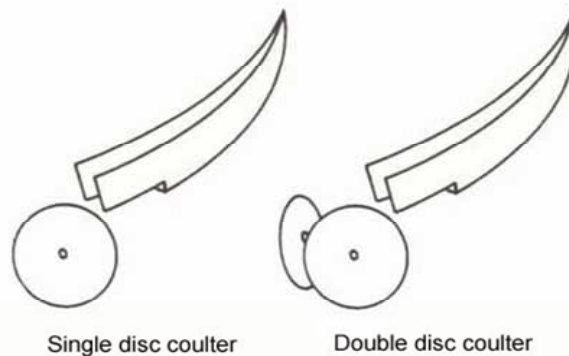

Figure 110: Single and double disc coulters type covering devices

The ability to adjust the disc coulters horizontally and vertically and to change the angle of the coulters in relation to the direction of travel provides flexibility in use and adjustment.

Figure 111 shows the side view of a double disc coulters used as a covering device. In this case, the discs are located immediately behind a seed-firming wheel. Provision for moving the discs horizontally is provided for by a simple clamp mechanism. Although not clearly shown, provision for adjusting the discs vertically and for changing their angle to the direction of travel is provided by sliding or rotating the round vertical standard to which the discs are attached.



Figure 111: Double disc coulters type covering devices following a seed-firming wheel

Figure 112 shows the rear view of a double disc coulters type covering device. In this case, the disc on the left is being used to cover the seed in a furrow created by a runner type furrow opener (i.e. located immediately behind the seed firming wheel) while the disc on the right is covering fertiliser that has been deposited into a furrow opened by a single concave disc opener.

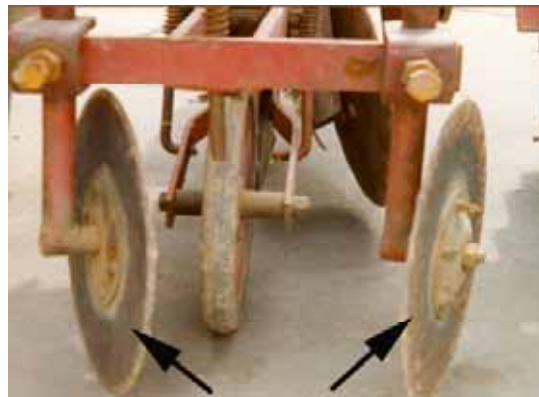

Figure 112: Double disc coulters, one covering seed the other covering fertiliser

Knife type covering devices

Knife type covering devices can be used singly or in pairs and are essentially elongated blades that are rigidly positioned upright on one or both sides of the furrow set so as to move soil back over the seed in the furrow. The knives can be straight or curved inwards and/or rearwards (Figure 113).

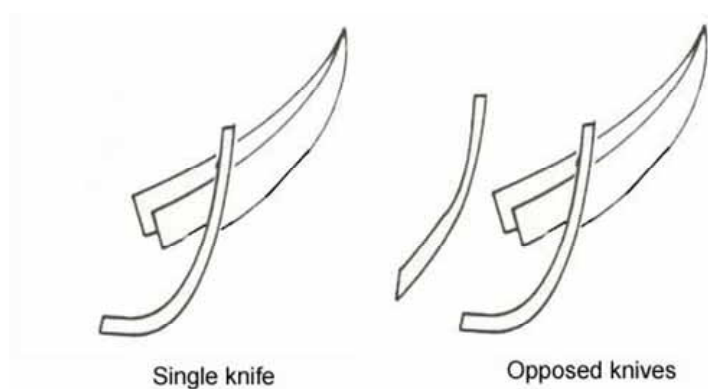

Figure 113: Knife type covering devices

Knife type covering devices need provision for vertical and horizontal adjustment as well as for rotating the knife (relative to the direction of travel) to change the degree of soil movement back into the furrow to cover the seed. They are predominately used in well-prepared seedbeds that do not have any significant surface residue. Figure 114 shows opposed knives positioned behind a seed-firming wheel. The knives are mounted independently on spring-tensioned members.



Figure 114: Opposed knife type covering devices

Paddle type covering devices

Paddle type covering devices can be used singly or in pairs and are essentially elongated blades that are positioned near horizontally on one or both sides of the furrow and have curved trailing ends that effect soil movement back over the furrow to cover the seed as shown in Figure 115.

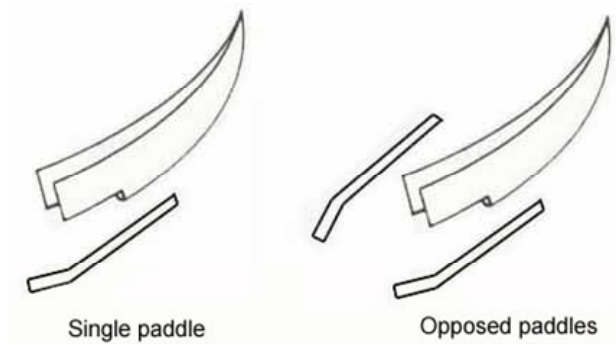

Figure 115: Paddle type covering devices

Paddle type covering devices have similar characteristics to knife types and can be used in similar situations. An opposed pair of paddle type covering devices shown in Figure 116.



Figure 116: Paddle type covering devices

Tine type covering devices

Tine type covering devices are generally used in opposed pairs and consist of tine standards mounted on either side of the furrow to which a wide variety of point, duckfoot and sweep type ground tools can be attached to effect soil movement back over the furrow to cover the seed. The typical positioning of these devices is shown in Figure 117.

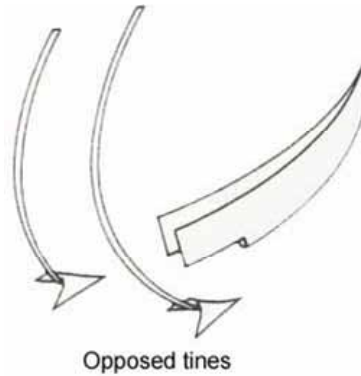

Figure 117: Tine type covering devices

Tine type covering devices are commonly used as covering devices on planting machines that have provision to effect full width (entire field surface) cultivation for weed control at time of planting. While the wide range of ground tool types available provide for a degree of flexibility, the major limitations are the high degree of disturbance caused to the seedbed and the limited residue-handling ability resulting from the close proximity of the tines.

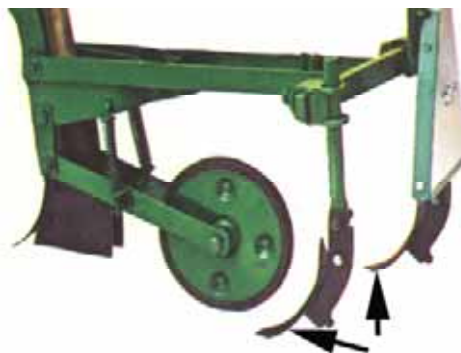

Figure 118: Tine type covering devices fitted with reversible point type ground tool

Figure 118 shows an example of tine type covering devices (fitted with a reversible point type ground tool) placed on either side and to the rear of a seed firming wheel.

Finger type covering devices

Finger type covering devices usually consist of one or more spring steel wire fingers positioned in various spatial arrangements to redistribute loose soil in the immediate row area and thereby cover the seed in the furrow (Figure 119).

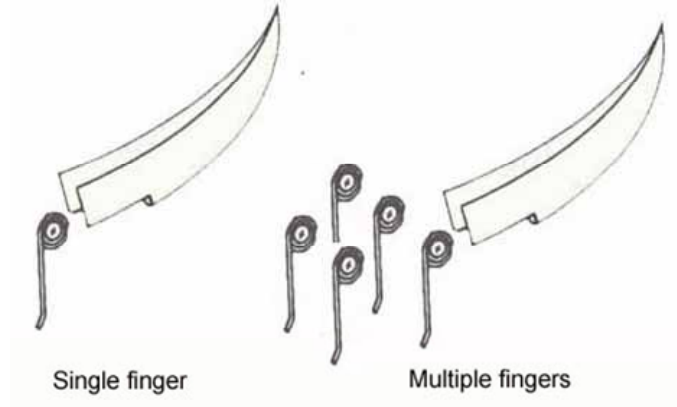

Figure 119: Single or multiple finger type covering devices

Finger type covering devices cannot cause significant soil displacement and tend to level rather than move soil. The degree of soil disturbance generally increases with increasing rake angle. However, increasing the finger rake angle to increase disturbance causes a corresponding reduction in residue-handling ability, particularly where multiple fingers are involved. Therefore, finger type devices, particularly multiple finger types, are more commonly used as entire seedbed levelling devices (see Group 7 of the soil-engaging components on page 102) rather than furrow covering devices.

A single finger type covering device is shown in Figure 120. In this application it is used to help cover fertiliser placed in a furrow created by a single disc couler.



Figure 120: A single finger type covering device

Finger wheel type covering devices

As a covering device finger wheels can be used singly or as opposed pairs (Figure 121). The range of finger wheel types used is similar, or in most cases identical, to those used as row preparation devices. However, the setting of the wheels is different. Covering finger wheels are set to engage with the soil and angled to move soil back over the row rather than set to have minimum contact with the soil and angled to move residue away from the row as is the case when used as row preparation devices.

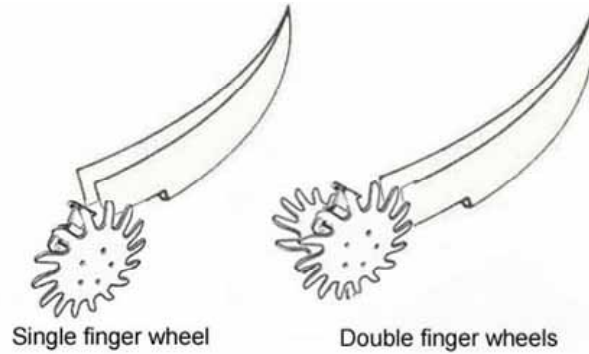

Figure 121: Single and double finger wheel covering devices

Examples of single and double finger wheels used as covering devices are shown in Figure 122.

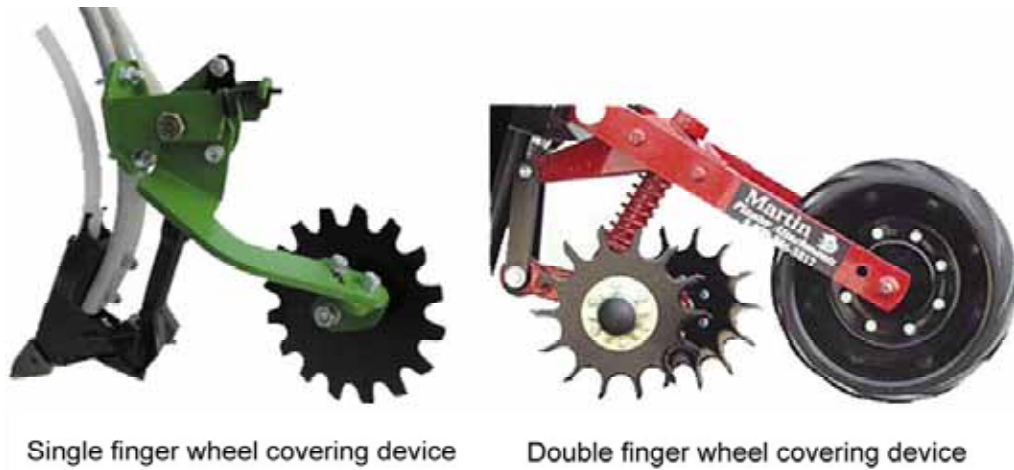

Figure 122: Examples of finger wheel covering devices

5.6 Group 6 – Row specific seedbed firming devices

Row specific seedbed firming devices are designed to firm the soil that covers the seed in a furrow. They differ from entire seedbed firming/levelling devices (i.e. Group 7 of the soil-engaging components, see page 102) in that their area of influence is the immediate row area and does not include the inter-row space. Most of the benefits attributed to row specific seedbed firming devices accrue from optimisation of soil compaction in the seed zone. However, over-compaction of the seedbed can have disastrous effects on seedling development, particularly emergence.

The optimum level of compaction is a compromise between the level that promotes beneficial effects (e.g. improved moisture status around the seed, stabilisation of conditions, etc) and the level that causes adverse effects (e.g. excessive mechanical impedance to shoot development, reduced soil aeration, etc).

The need for, and the type and setting of, a row specific seedbed firming device will be almost application specific and depend on factors such as soil type, soil condition/soil management (soil moisture, soil tilth, surface residues, etc) the type of crop to be planted, and the type and setting of the furrow opener used.

5.6.1 Functional requirements of row specific seedbed firming devices

Under almost all field conditions, firming the soil in the immediate seed zone has been shown to improve both seedling emergence and seedling growth. The significant improvement in emergence (commonly 15–20%) is attributed to a number of factors. These factors give rise to the *functional requirements* of row specific seedbed firming devices, which include to:

- assist in the general stabilisation of seedbed conditions by firming/compacting the loose soil covering the seed in the furrow;
- improve moisture availability and transfer to the seed by improving seed/soil contact;
- promote rapid and uniform emergence by manipulating both the depth and uniformity of soil cover over the seed;
- improve the prospects for emergence by reducing light penetration into the seedbed and the potential for sub-surface leaf emergence, particularly in the case of heavy clay soils;
- reduce the potential for insect damage to the seed by impeding their movement by firming the soil in the furrow;
- reduce the potential for weed seed germination by not firming soil in the inter-row space; and
- promote benefits that may result from alteration to the micro-relief of the seedbed.

In some cases, e.g. some twin inclined press wheel and finger wheel types, both the seed covering and soil firming functions can be accomplished.

Most row specific seedbed firming devices leave a depression or groove above the seeded row. This groove tends to concentrate the runoff from rainfall and has been shown to improve the moisture status in the seed zone. While this is obviously beneficial in ‘dry’ seasons, excessive accumulation of moisture in ‘wet’ seasons can be detrimental to seed germination and/or seedling emergence, establishment and growth. During heavy rainfall, soil may be washed into the groove. This may reduce emergence (due to excessive soil cover/depth above the seed) and promote the incidence of disease if it covers the stems of establishing plants.

While seedbed firming has been shown to improve emergence and establishment over a wide range of conditions, the effect is most apparent as soil conditions, particularly moisture, become limiting. The use of row specific seedbed firming devices, therefore, enables:

- crops to be established under conditions that would otherwise be called marginal or unsuitable for sowing;
- extension of the planting time available after effective rainfall.

5.6.2 Operational requirements of row specific seedbed firming devices

To achieve the functional requirements, the *operational requirements* of row specific seedbed firming devices include that:

- ideally, the shape of the device (width, profile, etc) be matched to the furrow shape so its action is not impeded by the firmer soil on either side of the top and walls of the furrow;
- the device be mounted so that it tracks directly over the centre of the furrow at all times;
- the device mounting be such that the pressure exerted on the soil can be easily adjusted and maintained to suit the particular seed type and seedbed conditions;
- the diameter of the device is such that its rolling action is not impeded by soil or residue conditions; and
- the type of device be selected or adjusted to suit the soil condition, e.g. selecting a particular type may reduce soil adhesion when working under moist clay soil conditions.

5.6.3 Types of row specific seedbed firming devices

Common row specific seedbed firming devices include press wheels, finger wheels and press coils as generally depicted in Figure 123. Press wheels are the most common type. This results largely from the diversity of types, shapes and sizes that exist. Nevertheless, the use of the finger wheel and press coil types is becoming more common. Each of these general types of row specific seedbed firming devices are discussed below.



Figure 123: Types of seedbed firming devices

Press wheel types

The large range of press wheel types precludes a detailed discussion of the attributes of each, however, most can be broadly classified as either 'over-centre', 'zero-pressure' or 'inclined' (Figure 124).

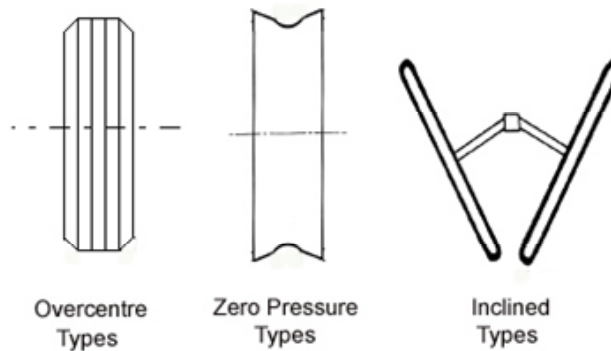

Figure 124: The three general types of press wheel

The relative merits of each type can be inferred from consideration of both their action and their reaction to:

- the type of crop planted; and
- the soil type and condition.

The ability of seedlings to emerge through compacted layers is somewhat species-dependent; the particular form of germination is a major determinant.

Monocotyledonous cereals and grasses (wheat, sorghum) which exhibit hypogeal germination (i.e. the coleoptile emerges) can emerge through compacted layers more easily than dicotyledonous plants exhibiting either epigeal germination (i.e. the hypocotyl emerges as in beans) or hypogeal germination (i.e. the epicotyl emerges as in peas). The major implications of this (in isolation from other factors) are:

- when a crop species known to be more sensitive to compaction is sown, press wheel pressure must be reduced; and
- where appropriate, the use of over-centre type press wheels should be avoided.

Soil type and condition can influence both the press wheel pressure and the press wheel type to be used. Well-prepared seedbeds in a friable condition require less pressure to give the same degree of seed/soil contact than a less well-prepared, cloddy seedbed. Where the level of soil moisture or soil structure is such that firming causes or induces a hard setting layer above the seed, press wheel pressure should be reduced and zero pressure or twin wheel systems used.

In general, over-centre type press wheels are favoured in reduced/no till situations where the seedbed conditions are generally less well-prepared and relatively high pressures over the seeded row are required to obtain good seed/soil contact. The inclined types are ideally suited for use in well-prepared or more friable seedbed conditions. The role of the zero pressure type is somewhere between the other two types. In all cases, press wheel pressure should be selected to suit the crop type and soil conditions.

The major variations within each type are further discussed below.

Over-centre press wheel types

Over-centre press wheel types generally have a flat, wedge or ribbed profile and for a given loading tend to exert maximum pressure at the soil surface directly above the seed (Figure 125).

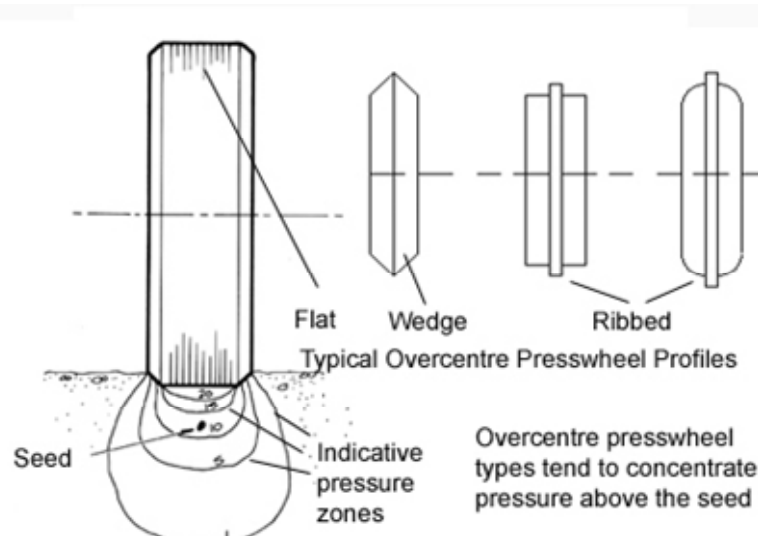

Figure 125: Typical over-centre press wheel profiles

Under reduced or zero tilled conditions, where narrow furrow openers are used, narrow wedge or rounded ribbed types may be required to match the furrow shape and so work effectively. Where wider openers are used, the flat or flat ribbed types may better suit the conditions. Metal, pneumatic and solid rubber types are available. Figure 126 shows examples of the flat, wedge and ribbed types of over-centre press wheel.



Figure 126: Some types of over-centre press wheel profiles

Zero pressure press wheel types

Zero pressure press wheel types usually have a generally concave profile resulting from a hard moulded rubber type, soft centre rubber type (i.e. moulded with hard edges and a soft flexible centre) or split packer metal types. For a given loading, these press wheel types tend to concentrate pressure above but to the sides of the seed zone (Figure 127).

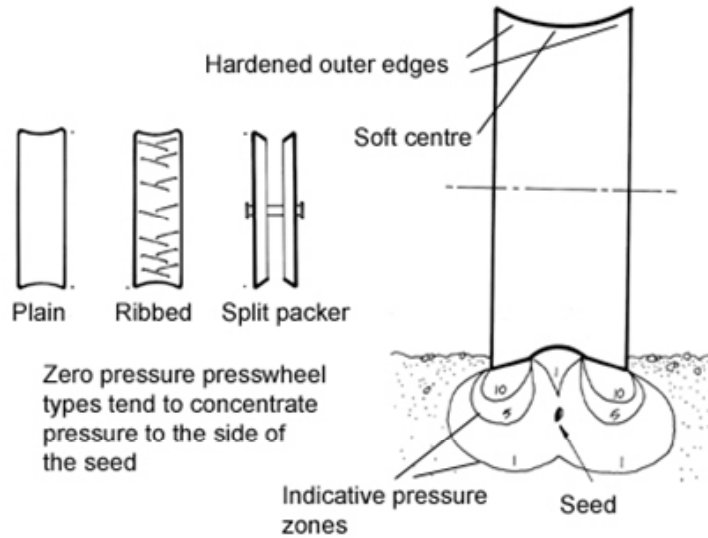

Figure 127: Typical zero pressure press wheel profiles

Zero pressure press wheels are particularly useful in friable seedbeds that have a tendency towards hard setting, particularly when more compaction-sensitive crops are grown. Soft centre rubber tyres with a ribbed surface can overcome some of the difficulties associated with hard setting soils. The impressions made by the ribs tend to dry and crack open, allowing emergence through an otherwise almost impenetrable barrier.

Figure 128 shows examples of the moulded, soft centre (plain and ribbed) and the split packer types of zero-pressure type press wheel.



Figure 128: Zero pressure press wheel types

Inclined press wheel types

Inclined press wheel types can have a variety of profiles but are generally narrow and inclined to the vertical and/or the direction of travel. Inclined press wheel types may be used individually or as twin inclined pairs (Figure 129) and are often called closing wheels because the angle of inclination assists both covering and closing the furrow.

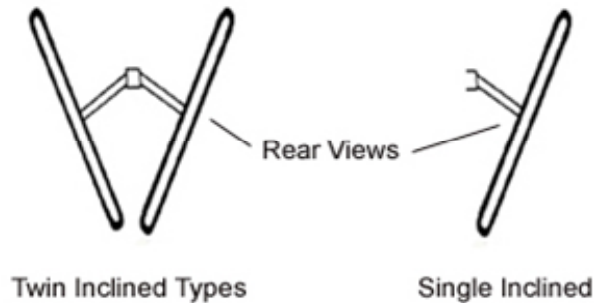

Figure 129: Inclined press wheel types

For a given loading, these press wheel types tend to concentrate the pressure around the seed but leave the surface soil above the seed relatively uncompacted as suggested in Figure 130.

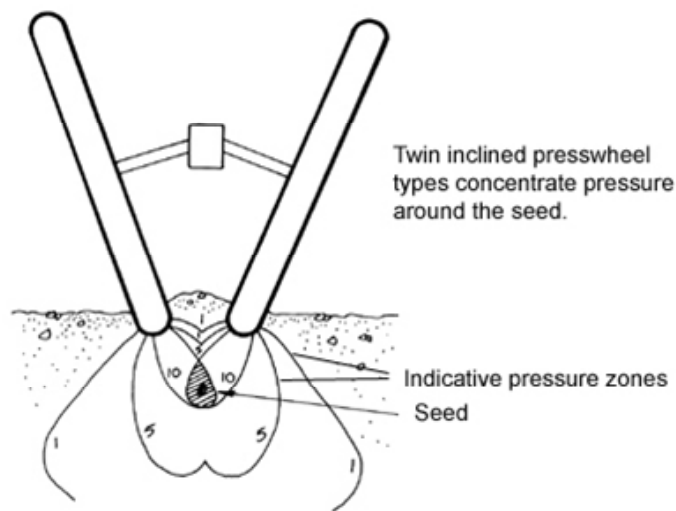

Figure 130: Indicative pressure zones for inclined press wheels

Twin inclined press wheel types can be aligned or staggered as shown in Figure 131.



Figure 131: Examples of Inclined press wheel types

Inclined press wheel types are suited for use over a wide range of soil types, soil conditions and crop types. Generally, single inclined press wheels are better suited for use with single disc coulters type furrow openers and twin inclined press wheels for use with double disc coulters type furrow openers.

Finger wheel types

Finger wheel, row specific seedbed firming devices close and compact soil around the seed with an action similar to that of twin inclined press wheels. While finger wheels used for row preparation or furrow closing may be used for seedbed firming, those specifically designed for firming differ in that their section is concave not flat, and the fingers are shorter and wider (Figure 132).



Figure 132: The typical shape of finger wheels used as a row specific seedbed firming device

The finger wheel may be staggered in the direction of travel and the angle of one wheel adjustable (Figure 133) to alter the degree of soil movement and seedbed firming.

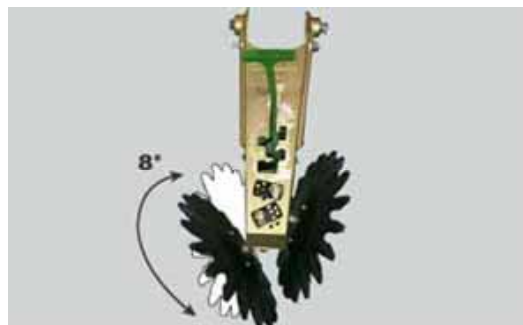

Figure 133: Finger wheel adjustment

While the soil is firmed within the immediate seed zone there is little side wall compaction and the surface soil above the seed is left loose and slightly mounded.

A finger wheel may be used in conjunction with an inclined press wheel (Figure 134).



Figure 134: A finger wheel and inclined press wheel combination

Coil press types

Each coil press, row specific seedbed firming device is manufactured from a single spring steel rod. The rod is rolled to form three coils and attached to an axle at a single central point (Figure 135).



Figure 135: A press coil seedbed firming device

When used as a row specific seedbed firming device, individual coil press units are arranged in gangs on a common shaft which is drawn at right angles or slightly offset to the direction of travel. The shaft is supported by two bearings and attached to the planter's mainframe via an adjustable spring loaded trailing arm (Figure 136).



Figure 136: A gang of coil press seedbed firming devices

The coil press is well suited for use in lighter soil types (Figure 137) where their action firms the seedbed but leaves the surface relatively uncompacted and their vibratory action reduces residue and soil adhesion to the coil.



Figure 137: Press coil unit in operation

When drawn at large angles (30–40°) to the direction of travel, the coil press unit can be used as a non row specific seedbed levelling device, as shown operating on the left hand side of the planter in Figure 138.



Figure 138: Coil press unit used as non row specific seedbed levelling device

5.7 Group 7 – Non row specific seedbed firming/levelling devices

Non row specific seedbed firming and/or levelling devices are designed to firm and/or level the entire field surface, i.e. exert their influence over both the row area and the inter-row space. When used, they usually perform the final soil working operation. These devices may be used on a planter in addition to, or as a replacement for, row specific seedbed firming devices.

5.7.1 Functional requirements of non row specific firming/levelling devices

Non row specific seedbed firming and/or levelling devices are generally used to achieve one or more of the following:

- firming the field surface to improve seed germination prospects by increasing seed/soil contact;
- levelling the field surface to facilitate uniformity in the depth of cover over the seed or the effectiveness of subsequent cultural practices, e.g. irrigation, harvesting, etc; and
- controlling small weeds at time of planting.

5.7.2 Operational requirements of non row specific firming/levelling devices

To achieve their functional requirements, the *operational requirements* for non row specific firming and/or levelling devices include the ability to:

- attach and remove the devices easily;
- adjust the aggressiveness and/or effectiveness of the firming, levelling or weed control functions;
- operate effectively over the range of field/seedbed conditions likely to exist at the time of planting; and
- not impair or otherwise restrict the manoeuvrability of the planting machine.

While non row specific firming and/or levelling devices can play an important role in the planting operation, it is generally considered that their seedbed firming action is inferior in improving crop seed germination prospects compared to that of row specific devices such as press wheels. This is because it is not generally possible to exert the correct pressure to meet the seedbed firming requirements and because non row specific devices can also improve the prospects for weed seed germination by firming the inter-row space.

5.7.3 Types of non row specific seedbed firming/levelling devices

Although a wide range of non row specific seedbed firming and/or levelling devices exist most can be broadly classified as either ‘roller’, ‘packer’ or ‘harrow’ types as generally depicted in Figure 139.

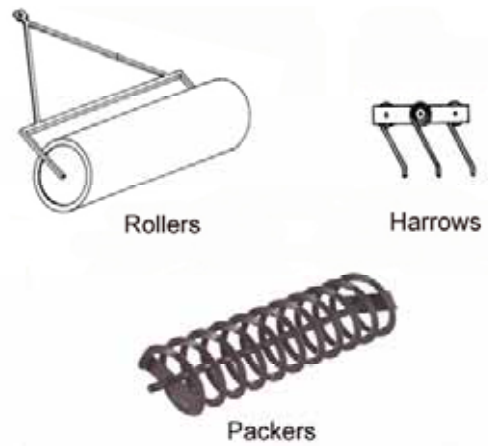

Figure 139: General types of non row specific seedbed firming/levelling devices

Roller type non row specific firming/levelling devices

Rollers firm and level the field surface by applying a vertical downwards force without any significant prior redistribution of surface soil. The uniformity of compaction and/or levelling largely depends on pre-existing soil surface conditions; hollows are removed only to the extent that the ridges can be compacted. As a result, uniform and adequate firming of soil around the seed is unlikely, particularly where the soil surface over the seeded row has been previously depressed by furrow opener and/or press wheel action.

A wide diversity of roller types, shapes and sizes exist and they are manufactured from an equally diverse range of materials including wood, metal and vehicle tyres (Figure 140).

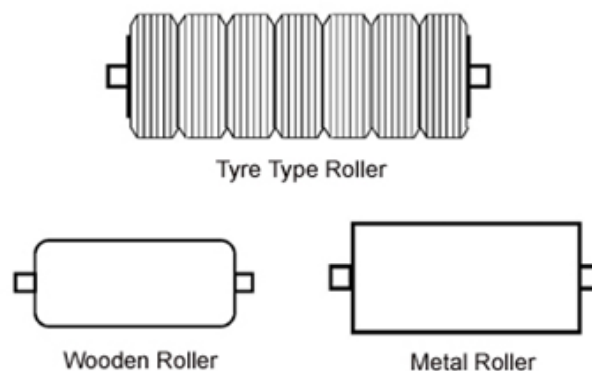

Figure 140: Some types of rollers used as non row specific seedbed firming devices

While the mass of tyre and wooden types is generally fixed, the mass of hollow metal rollers can often be adjusted by adding or removing water.

Rollers have limitations in relation to the adequacy and control of pressure exerted, but they can successfully operate over a wide range of soil types and conditions including high levels of surface

residue. Rollers are also cheaper than press wheels, so they are often preferred, particularly where seedbeds are well-prepared and level before planting. Figure 141 shows some examples of typical rollers.



Figure 141: Examples of roller types

Packer type non row specific firming/levelling devices

Packer type, non row specific firming and levelling devices have similar characteristics to roller types in that they firm the field surface by applying a vertical downwards force without any significant prior redistribution of surface soil. They differ significantly in that they usually leave the soil surface ‘rilled’ ‘dibbled’ or ‘grooved’, rather than flat, as a result of their usually discontinuous flat, round, tooth or ‘V’-shaped sectional profile. Their more aggressive action also provides for more clod pulverisation in addition to their firming and levelling action.

Spiral packers, cage rollers, toothed packers, disc packers, etc, are some of the range of packer types available. Figure 142 shows examples of flexible toothed and rigid coil type packers.

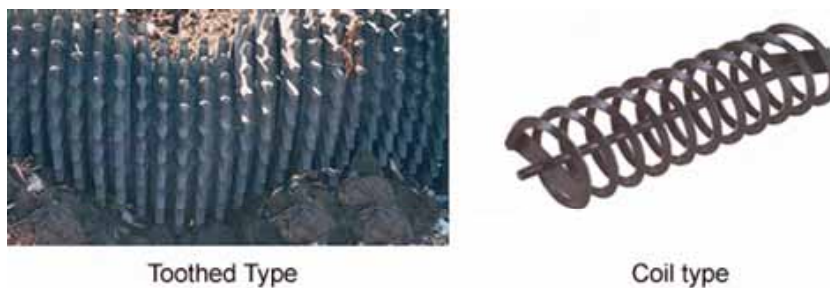

Figure 142: Examples of a coil packer and culti-packer type of firming device

Harrow type non row specific firming/levelling devices

Compared to roller and packer types that level and firm by rolling, harrows level and firm by a raking action that causes soil displacement and consolidation. This also provides for varying degrees of weed control, depending on the nature and extent of soil disturbance induced.

Peg, finger, leaf, chain and rotary are some of the wide range of harrow types available. While most are designed for use in well-prepared seedbeds with little or no surface residue, the finger and rotary types (Figure 143) are suitable for use where surface residues exist.

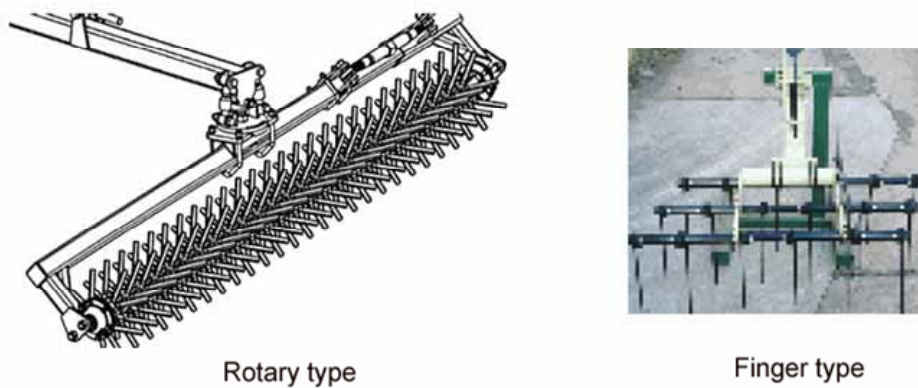

Figure 143: Examples of 'rotary' and 'finger' type harrows

There is considerable diversity within each type of harrow. For example, rotary harrows can be rigid or flexible across their working width (Figure 144) and be designed for shallow or deeper operational working depths.



Figure 144: Examples of rigid and flexible rotary harrows

In the case of finger harrows, finger spacing per bar and the number of bars (i.e. rows of fingers) vary, depending on the degree of disturbance and residue-handling ability required. Widely spaced fingers over several bars give improved residue-handling ability compared to close spaced fingers mounted on a single bar. Further, the ability to adjust the rake angle of the finger tines changes both the degree of disturbance and residue-handling ability of the harrow. In general, the degree of disturbance reduces and the residue-handling ability increases as the rake angle increases from the vertical tine position.

SECTION 6

Planter furrow opener depth control components

Effective planting depth is measured as the vertical distance from the seed to the soil surface immediately above the seed. As discussed in Section 2.2, and shown in Figure 145, there is an optimum effective depth of planting for each species and, for given conditions, this depth is typically related to seed size. Generally, small seeds (e.g. most pasture and vegetable crops) need to be planted at very shallow depths (e.g. 3–8 mm) to achieve optimum emergence percentages and the emergence percentage decreases rapidly as the effective depth of sowing increases. Larger seeds (e.g. cereal grain crops) generally need to be planted deeper (e.g. 30 to 60 mm) for optimum emergence percentages and the emergence percentage decreases with shallower or deeper effective depths.

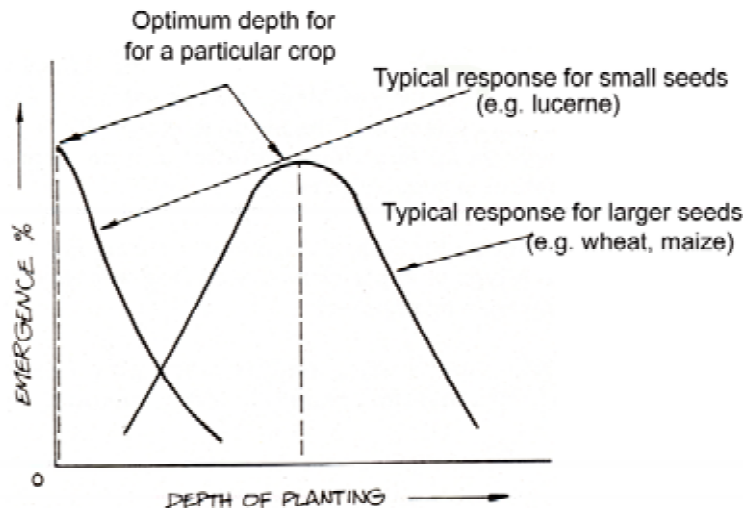

Figure 145: The typical effect of effective planting depth on crop emergence

In addition to influencing the overall emergence and establishment percentages, uniformity in effective planting depth also influences uniformity of emergence, because seeds planted at shallower depths typically emerge faster than seeds planted deeper.

Achieving the optimum effective planting depth essentially depends on two factors:

- the depth to which the furrow is opened relative to the original soil surface; and
- the depth of soil cover over the seed.

The depth of soil cover over the seed can be manipulated by many factors (including opener selection, the selection and setting of the seed covering and seedbed firming devices, etc) but the importance of the furrow opener's depth control mechanism in the initial setting and subsequent control of furrow opener depth cannot be over-stressed.

6.1 Functional requirements of furrow opener depth control mechanisms

As furrow depth is measured relative to the seedbed surface, the *functional requirements* of furrow opener depth control mechanisms include the ability to:

- open the furrow to the required depth;
- maintain uniformity of depth along the length of the furrow; and
- on multi-row machines, maintain the same depth on all openers across the width of the machine.

6.2 Operational requirements of furrow opener depth control mechanisms

To meet their functional requirements, the *operational requirements* of furrow opener depth control mechanisms include the ability to:

- maintain the required accuracy of depth control over the range of soil types and soil surface conditions likely to be encountered at time of planting; and
- easily adjust all openers to alter the furrow depth to suit particular crop requirements or soil type and conditions and the ability to adjust individual openers to compensate for wheel track depressions, etc.

6.3 Types of furrow opener depth control mechanisms

Depth is measured relative to the soil surface, so for accurate depth control, the opener depth control mechanism should be controlled by a sensor (usually a wheel or wheels) that:

- is in contact with, or otherwise senses opener depth from, the soil surface;
- is located as close as possible to the position where the opener operates; and
- has adequate flotation so as to be able to respond to variations in the soil surface elevation without excessive and/or undue variation in sinkage.

Although these principles generally apply, there is often a trade-off between accuracy of depth control and other considerations, such as overall machine cost or the compatibility of a particular depth control mechanism with other design features of the machine (e.g. opener design, residue-handling ability, row spacing). This, in turn, gives rise to a range of depth control mechanisms with varying levels of performance, particularly as field surface roughness increases.

While a large range of planter depth control mechanisms exist, most can be broadly classified as either ‘frame section gauging’ systems or ‘individual row gauging’ systems, as briefly discussed below.

6.3.1 ‘Frame section gauging systems’ for furrow opener depth control

With frame section gauging systems, the depth of all furrow openers attached to a particular frame or frame section is controlled by the height of the frame relative to the soil surface. To adjust the furrow depth, the machine frame or frame sections are raised or lowered (relative to the soil surface) by adjusting the position (relative to the frame) of the depth and/or transport wheels that support the machine frame in its working position. Figure 146 shows the side and rear view of a trailed, rigid hitch, four-bar, rigid framed cultivator/planter (seed metering and delivery equipment not shown) where:

- the dual purpose (duckfoot) tine type furrow openers are attached directly to, and are evenly spaced over, the four transverse tool bars;
- the depth/transport wheels are centrally located (relative to the bars) outside the frame; and
- the machine is working on a flat (level) seedbed surface.

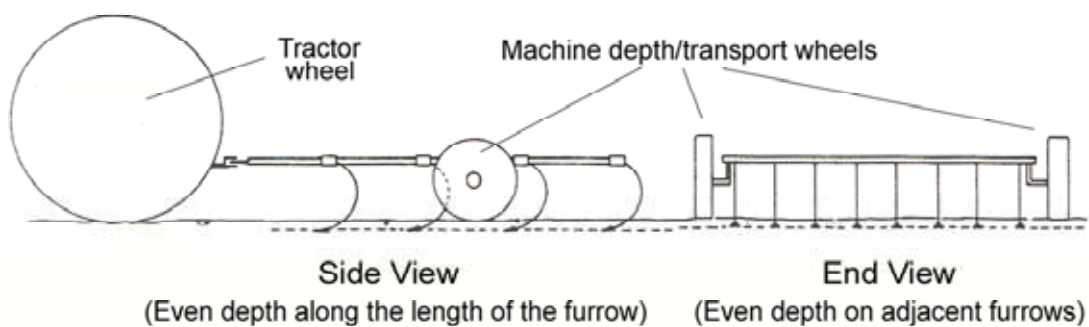

Figure 146: A trailed, rigid hitch, 4-bar, rigid frame cultivator/planter operating on a flat seedbed surface

It can be seen that:

- the position of the frame relative to the soil surface controls furrow opener depth;
- the attitude of the frame is controlled by both the depth/transport wheels and the tractor drawbar; and
- when the frame is parallel to a flat seedbed surface, depth control, both along the rows and between furrow openers across the width of the machine, is accurate.

Figure 147 shows the same machine operating on an irregular seedbed surface and clearly shows the limitations of the ‘frame section gauging’ system of furrow opener depth control. Nevertheless, it also serves to illustrate the general principles earlier outlined, i.e. the depth of the openers closer to the depth/transport wheels (i.e. those towards the outer edge of two central bars – bars 2 and 3) are more accurately controlled.

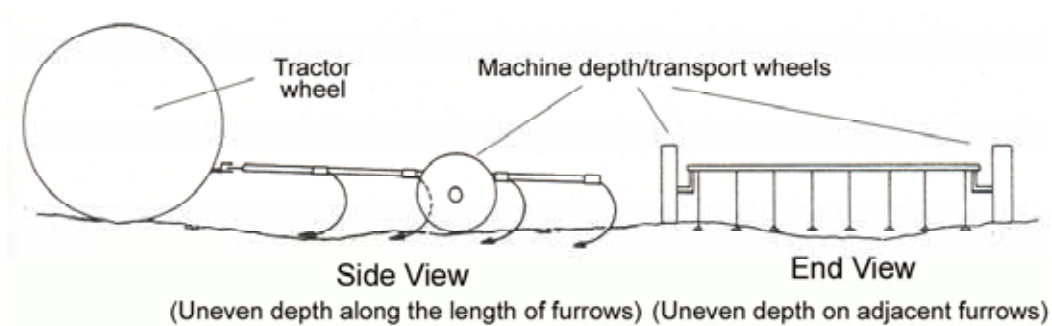

Figure 147: A trailed, rigid hitch, 4-bar rigid frame planter operating on an irregular surface

There are a number of ways to improve the accuracy of depth control on machines that use ‘frame section gauging’ systems. All involve additional cost and most involve reducing the effective width and/or length of the frame section. In essence, both approaches aim to bring the openers closer to a depth/transport wheel as shown in Figure 148.

Figure 148 shows the side and rear views of a trailed, flexible hitch, 4-bar, 3-section, flexible framed cultivator/planter working on an irregular seedbed surface. It shows the improvement gained by using a flexible hitch and a flexible frame to reduce length and width of the frame sections respectively. The flexible hitch shortens the effective length of the frame and thus improves depth control along the length of the furrow. The flexible frame divides the total width of the frame into a number of smaller individual frame sections, improving the uniformity of depth control across the width of the machine.

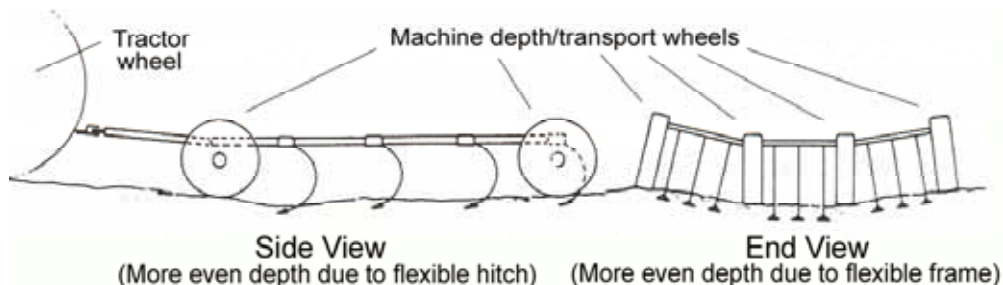

Figure 148: A trailed, flexible hitch, 4 bar, 3 section flexible-framed planter operating on an irregular surface

The frame section gauging method of depth control is often used on planters such as those commonly called ‘airseeders’ and ‘grain drills’, typical examples of which are shown in Figures 149 and 150 respectively.

Figure 149 shows a rear side view of a trailed rigid hitch, 4-bar, 3-section, flexible framed cultivator based airseeder type of drill planter. The individual furrow openers are attached via tine or standard to one of the three frame sections. The method of depth control is clearly ‘machine section gauging’, as the position of a frame section relative to the soil surface controls the depth of all openers attached to the frame section.

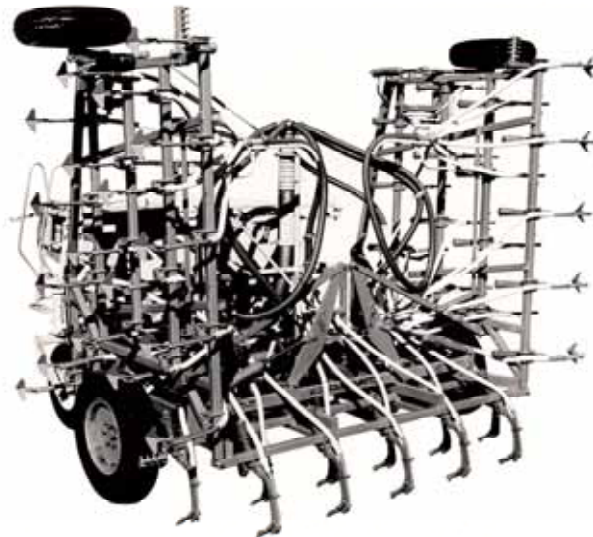

Figure 149: A drill planter utilising frame section gauging for furrow opener depth control

Figure 150 shows the rear side view of an Australian drill planter commonly known as a combine. This machine differs from some other drill planters in that it has a combination of tillage and planting ground tools attached to a rigid, 6-bar sub frame. The combination of tillage and planting ground tools provide full width cultivation for weed control at time of planting. Nevertheless, the method of furrow opener depth control is frame section gauging, as the depth of all the furrow openers is dependent on the position of the machine’s frame relative to the soil surface.



Figure 150: A drill planter utilising frame section gauging for furrow opener depth control

6.3.2 'Individual row gauging systems' for furrow opener depth control

With individual row gauging systems each opener has its own depth control mechanism, i.e. each opener is able to move independently of all others on the machine. Their movement (within a working range) is not constrained by the toolbar or mainframe to which they are attached.

There is a large range of individual row gauging depth control systems, but most can be broadly classified as either 'parallelogram' or 'trailing arm' systems. Variations within each type can be broadly sub-classified on the basis of the number and the location of the gauge wheels used.

Parallelogram systems of individual row depth control

In parallelogram systems, each furrow opener is attached to an individual frame section or unit that is attached to the machine's mainframe or toolbar by a parallelogram linkage. The parallelogram linkage allows the individual opener's frame section freedom of vertical movement, thus isolating it from variations in tool bar or mainframe height as well providing for independent movement relative to other such opener frames attached to the same toolbar or mainframe.

The height of the individual frame section relative to the seedbed surface, and hence the furrow opener depth, is controlled by a gauge/press wheel attached to the frame (Figure 151). Opener depth is changed by moving either the gauge wheel(s) or the opener up or down relative to the frame.

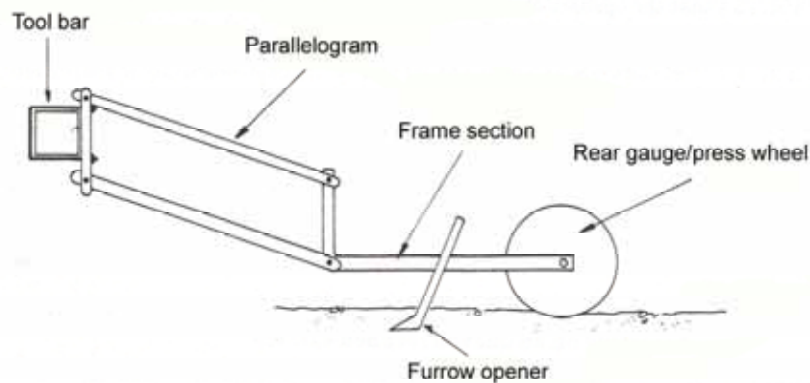

Figure 151: The parallelogram method of individual opener depth control

The position of the depth or gauge wheel(s) is important for accuracy of furrow opener depth control and these positions can be broadly classified as 'forward', 'beside' or 'behind' the furrow opener (Figure 152) or as a 'forward and behind' system (Figure 153). Depth or gauge wheels mounted 'forward', 'beside', 'behind' or 'forward and behind' the opener are generally defined as 'front', 'dedicated', 'rear' (Figure 152) and 'twin' (Figure 153) wheel systems respectively.

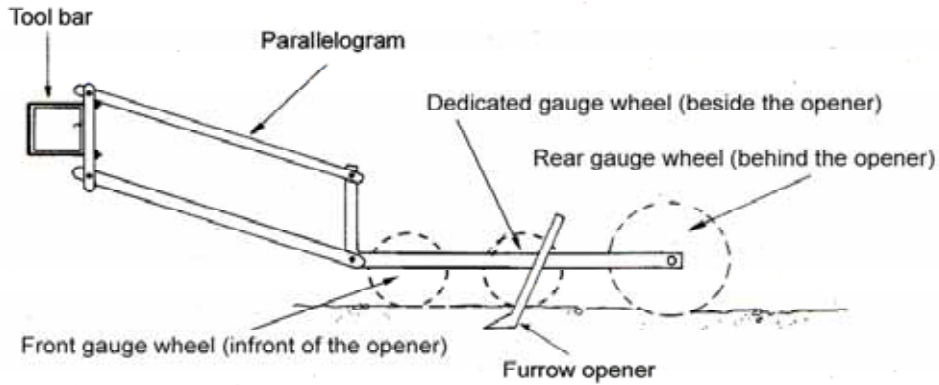

Figure 152: Gauge wheel positions for depth control on parallelogram systems

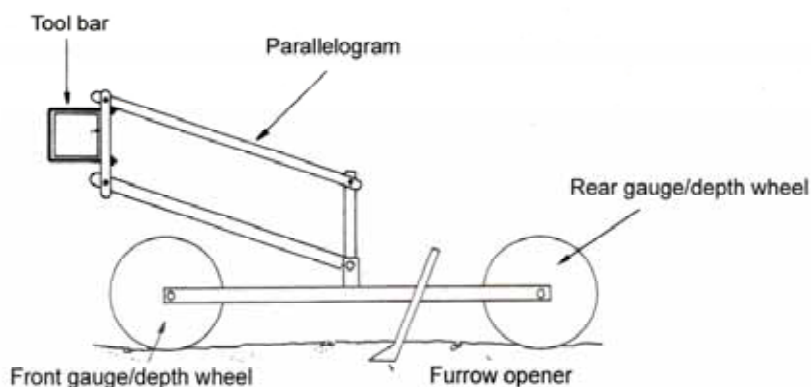

Figure 153: 'Twin' gauge wheel positions for parallelogram systems

Unlike the 'twin' wheel system in Figure 153, where the opener frame is pivotally attached to the parallelogram and its attitude depends on the relative vertical positions of the front and rear gauge wheels, the frame in Figure 152 is an extension of the parallelogram's rear vertical member. The parallelogram ensures the frame maintains the same attitude (essentially horizontal to the seedbed surface) throughout its range (arc) of vertical movement. This arrangement helps facilitate the positioning of, for example, seed boxes and seed metering systems on the frame and is typically used on unit type precision planters.

Dedicated gauge wheels (i.e. those mounted adjacent to the opener) give better depth control than either front or rear mounted gauge wheels (i.e. relative to the opener), essentially because of their closer proximity to the opener. Because of the averaging effect, the performance of the twin wheel configuration is generally considered to be somewhere between that of the dedicated and the front and/or rear wheel systems.

Nevertheless, front, rear and twin gauge wheel systems are common because, in addition to providing for depth control, they may be used for other purposes. For example, rear mounted gauge wheels can also be used as a row specific firming device, i.e. used as a press wheel. A front mounted gauge wheel could also be used as a roller type row preparation device. Further a disc coultter, with depth bands attached, may be used instead of a front mounted gauge wheel to control opener depth as well as acting as a soil and residue-cutting device.

Examples of the parallelogram method of furrow opener depth control with 'rear', 'dedicated' and 'front' and 'twin' mounted gauge wheels are shown on the following pages.

Rear gauge wheel type

Figure 154 shows the side view of a toolbar mounted unit type precision planter where the seed box, seed metering system (vacuum disc type) and runner type opener and rear gauge/press wheel are attached to a frame that is suspended from the toolbar by way of a parallelogram linkage. The depth of the furrow opener is independent of the tool bar (by virtue of the parallelogram) and controlled by the position of the rear gauge/press wheel's position relative to the frame.

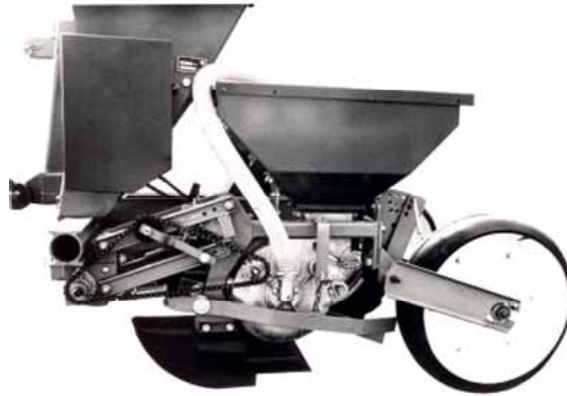

Figure 154: A unit planter utilising a 'rear gauge wheel' type of the parallelogram system

Dedicated gauge wheel type

Figure 155 shows a side view of a unit type precision planter where the seed box, seed metering system (vacuum disc), double disc opener and twin inclined press wheels are attached to a frame suspended from the toolbar by a parallelogram linkage. The depth of the furrow opener is independent of both the toolbar (by virtue of the parallelogram) and the press wheels (by virtue of the pivot point by which the press wheels are attached to the frame section) and is controlled by the dedicated gauge wheels positioned on either side of the double disc type opener.



Figure 155: A planter utilising a 'dedicated gauge wheel' type of depth control

Front gauge wheel type

Figure 156 shows the side view of a furrow opener frame mounted to a toolbar by way of a parallelogram. The frame position relative to the soil surface is controlled by the depth/gauge wheel mounted forward of the opener. Opener depth is therefore controlled by the front mounted gauge wheel and adjusted by moving the opener up or down relative to the frame.



Figure 156: A furrow opener utilising a 'front gauge wheel' type of the parallelogram system

Twin gauge wheel type

Figure 157 shows the side view of a runner opener attached to a frame which is connected to the machine's toolbar by way of a parallelogram linkage. Opener depth is controlled by the front and rear wheels supporting the frame to which the opener is attached.



Figure 157: A furrow opener utilising a 'twin gauge wheel' type of the parallelogram system

Trailing arm systems of individual row depth control

In trailing arm systems the furrow opener is connected either directly or indirectly to the machine's mainframe or toolbar by way of a pivotally attached trailing arm. This pivot point allows the opener freedom of vertical (and in some cases horizontal) movement in relation to the machine's mainframe or toolbar and to other openers across the width of the machine.

The position of the arm, and hence the opener's depth, is controlled independently by a wheel attached directly to the arm or by wheels supporting a frame attached to the arm. The position of the depth or gauge wheel(s) is important in relation to accuracy of furrow opener depth control and these positions can be broadly classified as being 'beside' or 'behind' the furrow opener (Figure 158) or as a 'forward and behind' system (Figure 159). Depth or gauge wheels mounted 'beside', 'behind' or 'forward and behind' the opener are generally defined as 'dedicated', 'rear' and 'twin' wheel systems respectively.

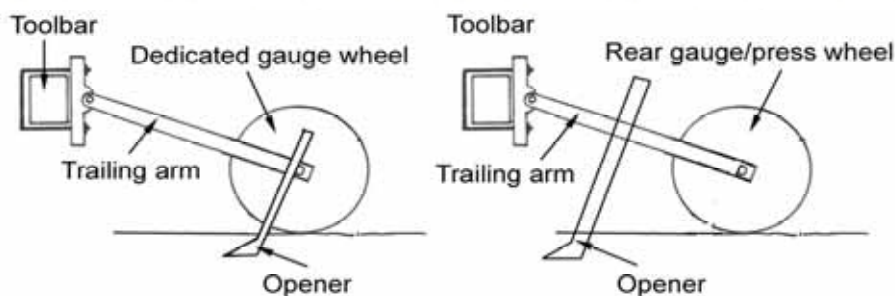

Figure 158: 'Dedicated' and 'rear' gauge wheel positions for trailing arm type depth control systems

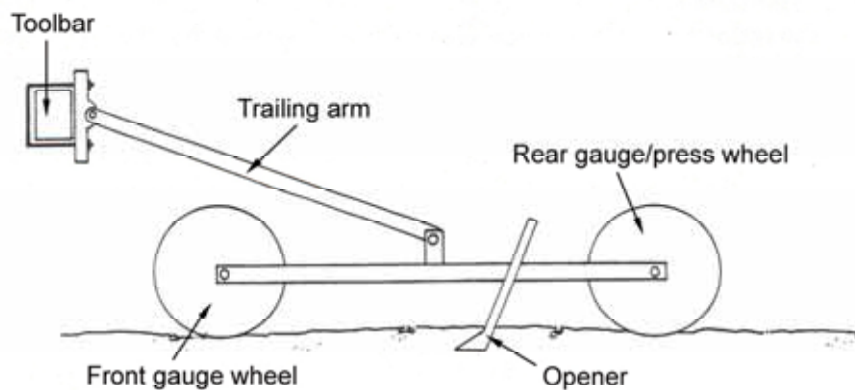

Figure 159: 'Twin' gauge wheel positions for trailing arm type depth control systems

Dedicated gauge wheels (i.e. those mounted adjacent to the opener) provide better depth control than the rear mounted gauge wheel (i.e. relative to the opener), essentially because of their closer proximity to the opener. Because of the averaging effect, the performance of the twin wheel configuration is generally considered to be somewhere between that of the dedicated and the rear wheel systems.

Nevertheless, both the 'rear' and 'twin' gauge wheel systems are commonly used because, in addition to providing for depth control, the wheels may be used for other purposes. For example, rear mounted gauge wheels can also be used as a row specific firming device i.e. used as a press wheel. The front gauge wheel in the twin wheel type could also be used as a roller type row preparation device.

Examples of the trailing arm method of furrow opener depth control with 'rear', 'dedicated' and 'twin' mounted gauge wheels are shown below.

Rear gauge wheel type

Figure 160 shows the side view of a combined seed and fertiliser placement system. The fertiliser is placed below the seed via a dropper tube behind the leading tine type opener. The seed is placed via the rearward curved shoe type furrow opener attached to the trailing arm pivotally mounted to the fertiliser tine and supported by a rear mounted gauge/press wheel.

The depth of the shoe type opener is adjusted by raising or lowering it relative to the trailing arm, the position of which, relative to the soil surface, is controlled by the rear press/gauge wheel.



Figure 160: A furrow opener utilising a rear gauge wheel type of the trailing arm system of depth control

Dedicated gauge wheel type

Figure 161 shows a single compound angle disc coultter opener mounted on a trailing arm. A dedicated gauge wheel mounted beside the disc controls the depth of the opener.



Figure 161: A dedicated gauge wheel type of the trailing arm system of depth control

Twin gauge wheel type

Figure 162 shows the side view of a narrow point type furrow opener mounted on a frame that is attached to the planter mainframe by way of a trailing arm. The twin wheels, i.e. the one positioned in front of and the one positioned behind the opener, control the position of the frame relative to the soil surface and hence opener depth.



Figure 162: A twin wheel type of the trailing arm system of depth control

SECTION 7

Planter seed metering components

Seed metering devices are those devices that meter the seed from the seed box and deposit it into the delivery system that conveys the seed for placement on or in the seedbed. The types of seed metering devices and their functional and operational requirements are discussed below.

7.1 Functional requirements of seed metering devices

The major *functional requirements* of seed metering systems are to:

- meter the seed at a predetermined rate/output (e.g. kg/ha or seeds/metre of row length);
- meter the seed with the required accuracy (spacing) to meet the planting pattern requirements (i.e. drill seeding, precision drilling, etc); and
- cause minimal damage to the seed during the metering process.

7.2 Operational requirements of seed metering devices

To meet their functional requirements, the *operational requirements* for seed metering systems include:

- the ability to meter the range of seed types to be planted by the machine (e.g. the range of summer crops or a range of both summer and winter crops);
- the ability to meter these seeds over the range of seeding rates required to meet individual crop and/or particular environmental conditions (e.g. cereal crops are generally planted at higher rates than pulse crops; planting rates for crops are usually higher when grown under irrigated rather than dryland conditions);
- the ability to maintain the predetermined rate (output) and spacing (accuracy) over the range of conditions likely to exist at planting (e.g. over the range of soil conditions, surface roughness, surface slope, etc), field speeds, levels of seed in the seed box, surface residues (that may tend to block or stall chain drives, etc); and
- a high level of operational reliability, which is important in view of the generally narrow planting window available.

In addition, the size of the seed box or boxes, the ease of filling and emptying these boxes, and the ease of calibrating, cleaning and adjusting the seed metering rate must all be considered as all affect the overall performance and efficiency of the planting operation.

7.3 Types of seed metering devices

A large range of seed metering devices exist, but most can be classified as either 'precision' or 'mass flow' depending primarily on their principle of operation and the resulting planting pattern.

Precision type seed meters attempt to select single seeds from the seed lot and deliver them from the meter at a preset time interval. If this time interval is maintained as the seed is being delivered to, and placed in, the seedbed, the seeding pattern will be one where the seeds are equidistant along the furrow, i.e. a precision drilling pattern. A precision meter plus an accumulation device enables a hill drop pattern while a precision meter plus an accumulation and an indexing device will enable a check row planting pattern. In general, precision type seed meters are used for crops that:

- are usually planted at relatively low seeding densities (typical range 10–150 seeds/m²);
- are planted in relatively wide rows (typical range 250–900 mm);
- have a relatively narrow range of plant populations from which optimum yields can be expected for a given environment; and
- usually have a yield response to evenness of plant spacing along the row.

Crops usually planted using precision seed metering devices include most horticultural crops and maize, sorghum, sunflower and beans. Typically, precision seed metering systems are used on what are generally referred to as 'row crop' planters.

Mass flow meters do not attempt to meter individual seeds but rather attempt to meter a consistent volume of seed per unit of time to give an average seed spacing equal to the desired spacing, i.e. a drill planting pattern. In general, mass flow type seed metering devices are used for crops that:

- are usually planted at higher seeding densities (typical range 150–1500 seeds/m²);
- are planted in relatively narrow rows (typical range 80–350 mm); and
- can tolerate considerable variation in both seeding rate and uniformity of seed spacing without a significant loss in yield (provided the population is above some minimum value for the existing environmental conditions).

Cereal grains and grass pastures are examples of crops planted by mass flow seed metering devices. Typically, mass flow seed metering systems are used on planters generally referred to as 'broadcast', 'drill' and 'airseeder'.

7.3.1 Mass flow seed metering devices

Common mass flow seed metering systems can be broadly classified as either ‘stationary opening’, ‘external force feed’ (fluted and peg/studded rollers) and ‘internal force feed’ (double run) types (Figure 163).

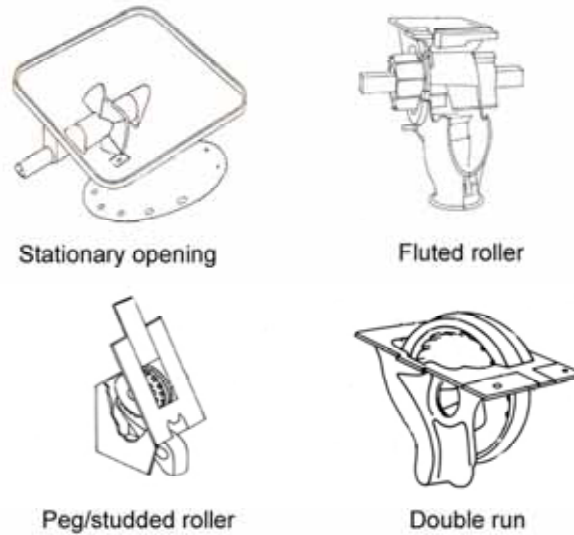

Figure 163: General types of mass flow seed metering devices

Stationary opening type seed meters

Stationary opening type seed meters are simple devices, essentially consisting of a seed box, an agitator and a variable sized outlet orifice. The orifice size is usually adjusted by sliding a plate that increases or decreases the size of an opening or by rotating a plate to expose a different orifice size.

Figure 164 shows a stationary opening type seed meter that uses a sliding plate to vary the size of the outlet(s) in the base of the seed box.



Figure 164: A stationary opening type seed meter using a sliding plate to adjust the outlet size

In Figure 164 there are two fixed size outlets in the base of the seed box. An adjustable plate with similar hole sizes is mounted below the base. It can be rotated relative to the holes in the seed box to vary the size of the outlet and hence the seeding rate. The agitator used to ensure seed does not bridge or otherwise fail to pass through the opening at a reasonably uniform rate is also clearly shown. In this case, the seed falls through the openings directly onto a spinning disc that spreads the seed over the seedbed surface in a broadcast planting pattern.

In the stationary opening type of seed meter (Figure 165) a rotating plate with varying hole sizes around its periphery is used to adjust the size of the opening in the base of the seed box.

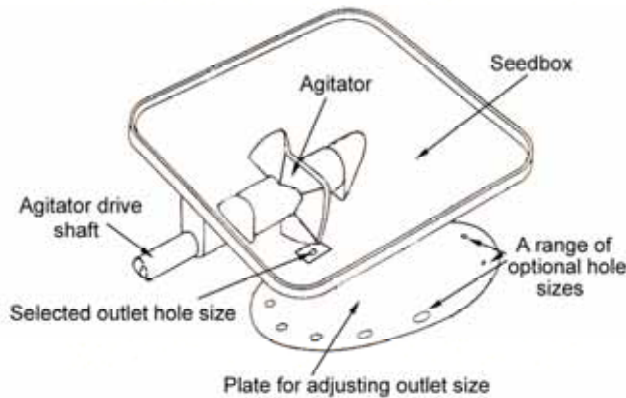

Figure 165: A stationary opening seed meter using a rotating plate to adjust the outlet size

As in Figure 164, the seeding rate is controlled by changing the size of the outlet orifice in the base of the seed box by rotating a plate with various hole sizes around its periphery until the appropriate hole size is positioned over the box outlet.

While most stationary opening types of seed meter utilise a shaft-driven agitator, some rely on a small diameter flexible spring wire that is attached to the top of the seed box then passes through the outlet orifice far enough to make contact with the ground. As the machine moves forward the spring wire ‘jiggles’ (vibrates) and so provides a degree of agitation to the seed in the box.

For uniformity in seeding rate, the outlet orifice has to be above some minimum size (in relation to seed size) and the seed lot must exhibit a high degree of ‘flowability’. If the seeds have a tendency to pack or otherwise cling together in the seed box, flow through the orifice may be irregular, intermittent or cease completely.

While stationary opening type seed meters are still extensively used on many broadcast type planters, they have largely been replaced in drill type planters. Nevertheless, because of their simplicity and low cost they are still used for specific applications. For example, they are still commonly used in vegetable and grain crop production in many small-scale, low-resource agricultural systems.

The stationary opening type seed meter is also used in some low-cost pasture improvement programs. Figure 166 shows a stationary opening type seed meter (utilising a flexible spring wire agitator) mounted on the frame of a deep ripper used for pasture renovation. The seed from the meter simply falls onto the soil surface which has been disturbed by the tine type furrow opener.



Figure 166: An example of a stationary opening type seed meter used for pasture renovation

External force feed type seed meters

External force feed seed metering systems employ a rotating member in the form of a fluted or a peg/studded roller to regulate seed flow from the seed box to the seed delivery system. In both cases, as the roller rotates the seed is moved and metered by the external surface of the roller (Figure 167).

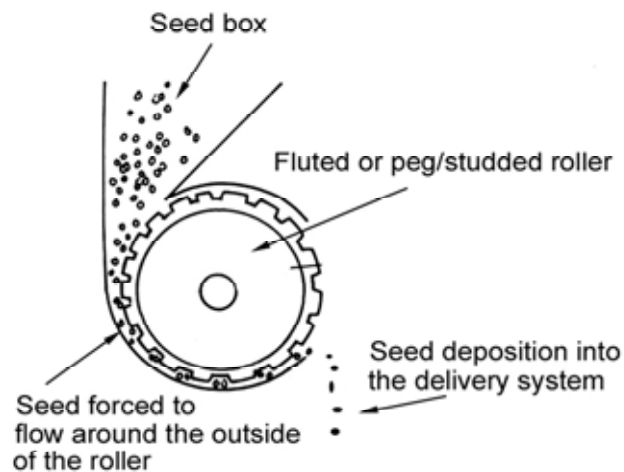

Figure 167: General principle of operation of 'external force feed' seed meter types

While the principle of operation and the application is similar for both fluted and peg/studded roller types, the method of adjusting the seeding rate differs significantly as discussed below.

Fluted roller types

Figure 168 shows the general form of the fluted roller type of external force feed seed meter. This type of meter essentially consists of a fluted roller, a sliding cut-off and an adjustable flap. The rotating fluted roller and the stationary cut-off are moved axially as a unit to change the exposure of the fluted roller to the seed. The adjustable flap can be moved closer to, or further away from, the roller to change both the cross-section area through which seed can move and the extent the seed has to be moved by the roller before it can exit the meter.

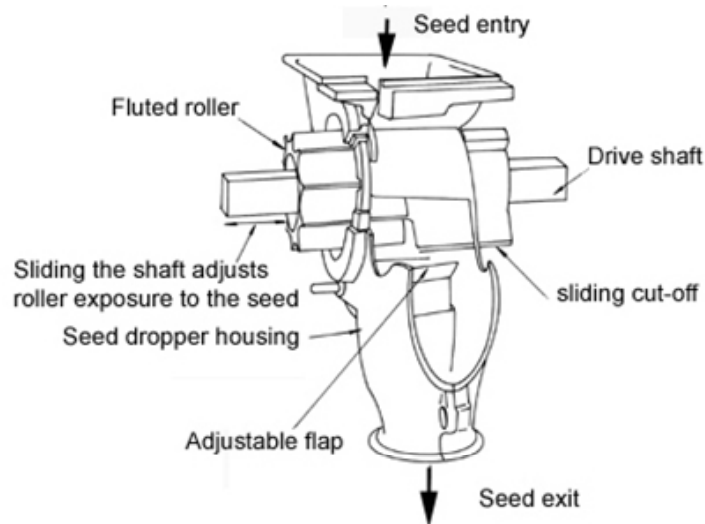

Figure 168: The general form of the fluted roller type of external force feed seed meters

The seeding rate on the fluted roller type meter can be adjusted by one or more of the following:

- adjusting the speed of rotation of the fluted roller relative to ground speed (i.e. adjust the velocity ratio);
- sliding the shaft axially to change the length of the flutes exposed to the seed; and/or
- adjusting the flap position to accommodate different seed sizes, alter the seeding rate or, when fully opened, facilitate cleaning of the meter.

Typically on a multi-row machine, there is one meter for each row and all meters are driven from a common square shaft passing through the centre of each roller and extending across the full width of the machine.

In general:

- the speed of the shaft is adjusted by a gear box located in the drive train from a ground wheel to the shaft;
- to expose more or fewer of the fluted rollers to the seed, the common shaft is moved axially via a lever at one end of the shaft; and
- the outlet flap has to be adjusted individually on all meters.

On fluted roller type meters the continuity of seed flow from the meter depends on the rotational speed of the roller. At higher (normal) speeds of rotation a continuous stream of seed is delivered from the meter. At below recommended speeds the seed flow may be pulsed as each individual flute discharges seed to the meter's outlet. Reducing the exposure of the fluted roller to the seed lot and at the same time increasing its rotational speed to give the same metering rate is one way to improve the continuity of seed flow at low seeding rates. The selection of a meter with helical rather than straight cut flutes on the roller can also be an option.

Figure 169 shows the front view of a fluted roller type of external force feed seed meter with the fluted roller moved axially so as to have no exposure to the seed.



Figure 169: Front view of a fluted roller type seed meter

Peg or studded roller types

While all external force feed meters have the same principle of operation (Figure 167), the peg or studded roller type differs from the fluted roller type in that:

- the straight-cut or the helical-cut flutes (i.e. grooves cut in the roller) that meter the seeds are replaced by raised pegs or studs (i.e. protrusions on the roller) for the same purpose; and
- the roller remains in a fixed position, i.e. the roller cannot be moved axially as a method of adjusting the seed rate.

Figure 170 shows the rear view of a peg or studded roller type of external force feed seed meter. It clearly shows the pegs or studs that replace the flutes and that the roller, while free to rotate, cannot be moved axially to change the exposure of the roller to the seed lot.



Figure 170: The rear view of a peg or studded external force feed seed metering system

Typical methods of changing the metering rate of peg or studded roller type external force feed meters include:

- adjusting the speed of rotation of the peg or studded roller in relation to ground speed (i.e. adjusting the velocity ratio);
- adjusting the flap or base plate position to accommodate different seed sizes, altering the seeding rate or when fully opened facilitating cleaning of the meter; and
- optional methods, such as using an adjustable slide to change the size of the seed entry orifice, using inserts that essentially increase the diameter of the roller and reduce the depth of the pegs or studs, and providing optional roller types.

Typically on a multi-row machine, there is one meter for each row and all meters are driven from a common round or square shaft passing through the centre of each roller and extending across the full width of the machine. The base plate position of all meters is usually adjusted by rotating a common shaft to which all base plates are attached.

Internal force feed type seed meters

Internal force feed seed metering systems, often referred to as double run seed meters, employ a rotating member in the form of a double-sided flanged disc. The width of the flange and the size of corrugations on their internal surface differ on each side of the disc, giving what is termed a fine and coarse side of the disc. As the disc rotates seed, directed to either the fine or coarse side of the disc (hence the term double run), is moved and metered by this corrugated internal surface of the flange (Figure 171).

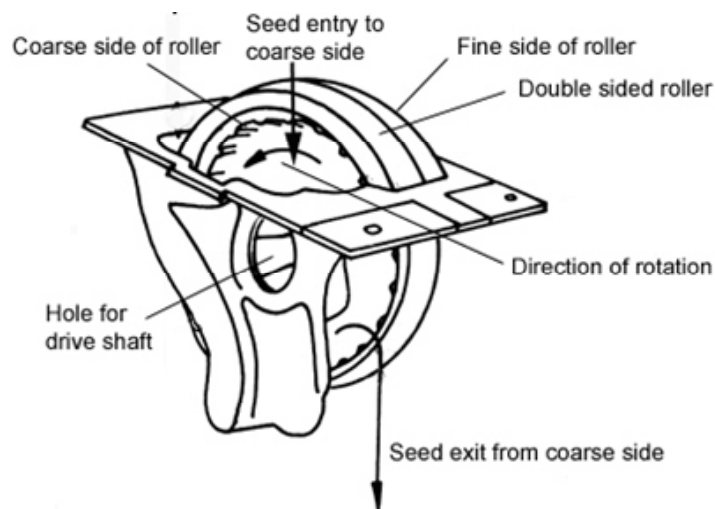

Figure 171: The path of seed movement through an internal force feed type seed meter

Seed is directed to either the fine or the coarse side of the meter by moving a slide or a flap inside the seed box. Typically, the coarse side is used to meter larger seed while the fine side is used to meter smaller seed. For very high seeding rates, small seed may be directed through the coarse side of the meter.

Typical methods of adjusting the seeding rate include:

- adjusting the speed of rotation of the roller in relation to ground speed (i.e. adjust the velocity ratio);
- adjusting the flap or the slide to direct seed to the fine or coarse side of the meter; and

- in some particular types, adjusting an insert in the lower portion of one side of the meter housing to effectively reduce the width of the flange and hence the seeding rate.

Figure 172 shows the side view of a typical internal force feed or double run seed meter while Figure 173 shows the front view of three such meters mounted under a common seed box.



Figure 172: The side view of a typical internal force feed type seed meter



Figure 173: Front view of three internal force feed seed meters under a common seed box

7.3.2 Precision seed metering devices

Unlike mass flow seed meters, precision meters attempt to meter single seeds. While there is a large range of precision metering devices, most can be broadly classified as ‘plate’, ‘belt’, ‘disc’, ‘drum’ or ‘finger’ types. Classification largely depends on the design and/or shape of the principle moving element that enables seed singulation (i.e. the selection of single seeds from the seed lot) (Figure 174). Nevertheless, considerable variation exists within each type and these are discussed below.

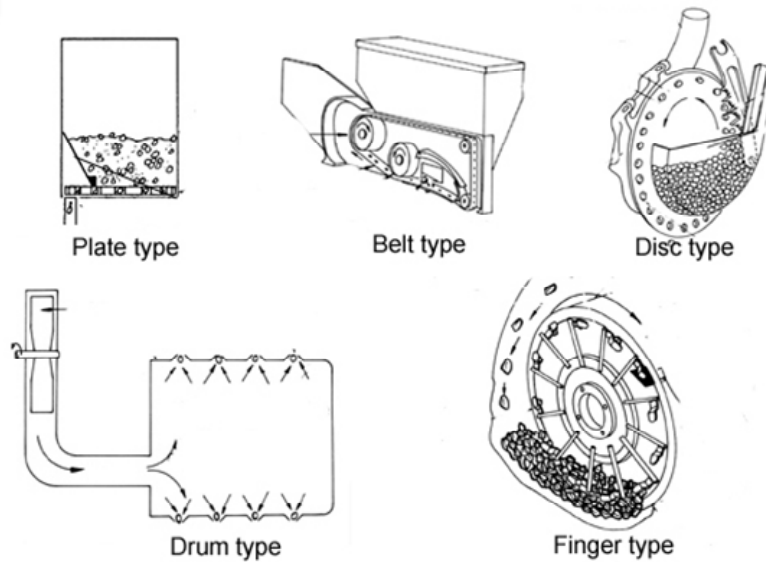

Figure 174: General types of precision seed metering devices

Plate type precision seed meters

Plate planters are taken here to be those that principally use a moving plate with indents, i.e. holes, cells or cups, around its periphery and metering performance is generally highly dependent on matching the size (length, breadth and thickness) of the indents to the size of the seed. Plate meters can be sub-classified as ‘horizontal plate’, ‘inclined plate’ or ‘vertical plate’ types (Figure 175).

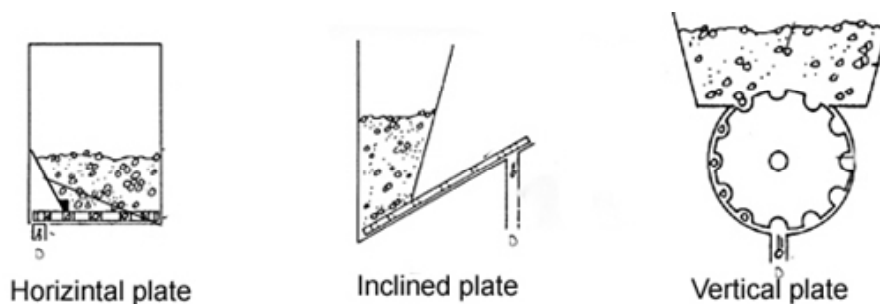

Figure 175: Types of plate seed meters

Vertical plate type meters can be further sub-classified as ‘mechanical’, ‘air assisted’ or ‘brush assisted’, depending on the method of singulation.

Horizontal plate type precision seed meter

Figure 176 depicts the typical form of a horizontal plate meter. The plate has a number of holes or cells around its periphery and a portion of the plate is exposed to the seed. If the hole or cell is of the appropriate size, a single seed will fall into it as it passes through the segment where the plate is exposed to the seed. The plate then moves the seed to the non-exposed segment, where it is ejected or falls due to gravity into the seed delivery tube. A metal pawl at the interface between the exposed and non-exposed portions ensures that no seed other than that fully enclosed in the hole or cell passes from the seed box.

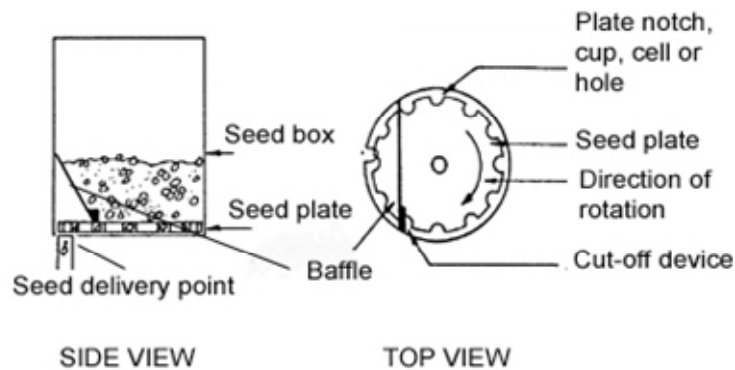

Figure 176: Side and top views of a horizontal plate meter

The seeding rate is altered by changing the velocity ratio of the plate or by changing to a plate with more or fewer holes or cells. In general, the hole or cell diameter and the plate thickness is varied to suit a particular seed size. Accurate performance depends on the use of graded seed and the selection of an appropriate plate to suit that seed size.

Figure 177 shows the top and rear view of a horizontal plate meter. The top view shows that portion of the plate exposed to the seed at the base of the seed box. It shows the cut-off pawl that ensures only the seed in the cells can exit from the seed box. The rear view shows that portion of the plate not exposed to the seed. The ejector pawl is folded back to show a cell positioned over the seed delivery tube.

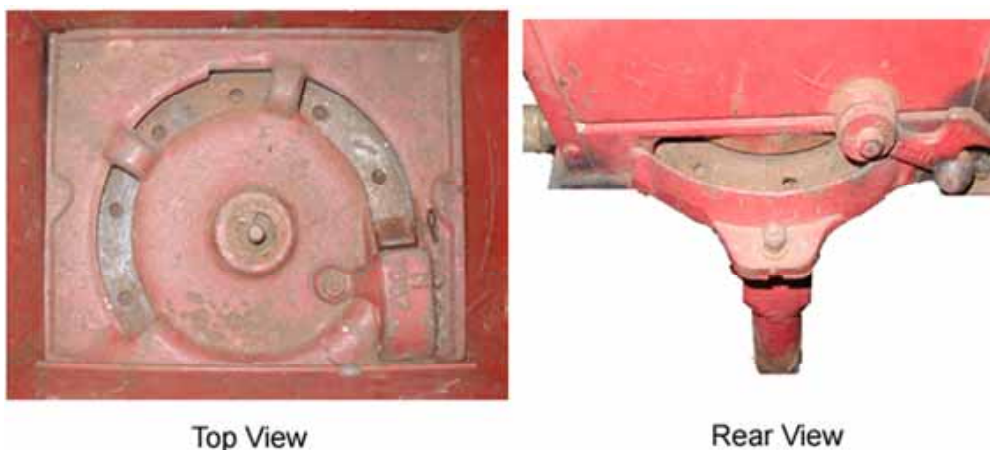

Figure 177: The top and rear views of a horizontal plate seed meter

Inclined plate type precision seed meter

Inclined plate meters have the same components and operating principle as the horizontal plate meter except the plate rotates in an inclined plane (Figure 178). In general, the segment of the plate exposed to the seed is smaller and because of the plate's inclined angle the cut-off mechanism need not be so aggressive; it is often a foam roller. While the incline plate meter has limitations in common with horizontal plates (i.e. the need to have graded seed and matched cells) they cause less damage to fragile seeds due to the less aggressive singulation process.

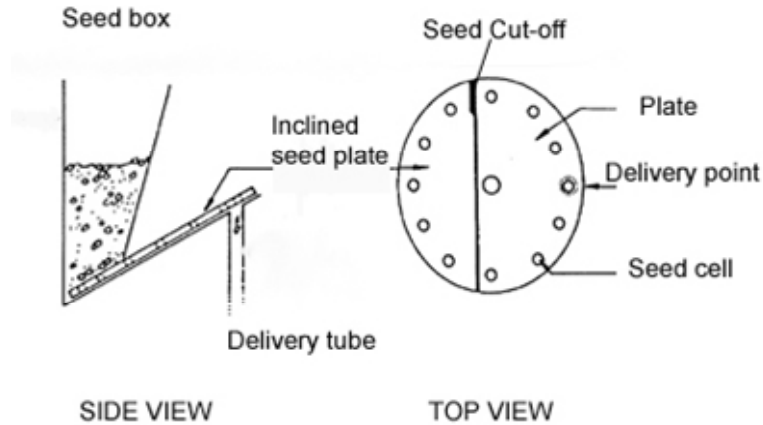

Figure 178: Side and top views of an inclined plate seed meter

Figure 179 shows the inclined plate in the base of the seed box with and without the seed baffle plate in place. In the operating position, the baffle restricts the portion of the plate exposed to the seed. The foam cut-off pawl is shown when the baffle has been removed.



Figure 179: Views of the inclined plate with and without the seed baffle in place

Figure 180 shows the rear view of the same meter. It shows the base of the seed box and hence the plate is inclined to the horizontal. It also shows the plate drive mechanism, the seed ejector pawl and the seed delivery tube.



Figure 180: the rear view of an inclined plate type seed meter

Where a cup-like indent is used instead of a hole in the plate to separate the seeds, there is no need for a cut-off device; any seed not partially enclosed by the cup simply falls back to the seed lot.

A limitation of the inclined plate meter is the tendency for seeds to be dislodged from the holes or cells before being deposited into the seed delivery tube, particularly when operating at higher metering rates. This is caused by excessive vibration when travelling over irregular seedbeds and/or the centrifugal force generated by higher plate speeds. The latter can be overcome by using two plates to feed one seed delivery tube. This enables the plate rotational speed to be halved for a given metering rate. Figure 181 shows a unit with two inclined plates feeding a common seed delivery tube. A baffle between the seed box and the metering chamber is used to adjust the quantity of seed exposed to the lower portion of the plates. Because the plates have a high degree of inclination there is no requirement for a cut-off device.



Figure 181: Twin inclined plate meters delivering seed to a common delivery tube

Another limitation of the inclined plate meter is that the seed is released from the plate at its highest point relative to the seedbed surface. For a given meter height this requires a longer delivery tube, which has implications for the maintenance of uniformity in seed spacing during the delivery process.

As for other plate meters, the seeding rate is changed by changing the plate's velocity ratio or by changing to plates with more or fewer holes or cells. In either case, the seed needs to be graded and the holes or cells matched to this seed size for optimal metering performance.

Vertical plate type precision seed meters

Vertical plate type precision seed meters can be sub-classified as ‘mechanical’, ‘air assisted’ and ‘brush assisted’, depending on the method of singulation (Figure 182).

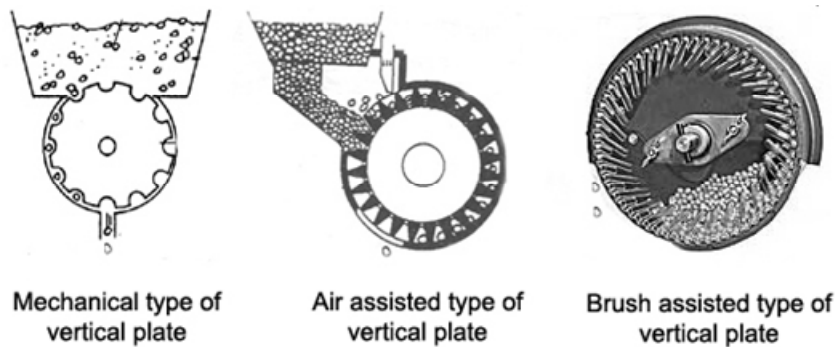

Figure 182: General types of vertical plate meters

Mechanical vertical plate type precision seed meter

Figure 183 shows the typical form of a mechanical vertical disc type seed meter. As with the horizontal and inclined plate types, seeds are separated by mechanical means, i.e. dependent on matching the seed size to the size of the cells in the plate. The top of the plate is exposed to the seed and the close tolerance between the disc and the housing provides for both cut-off and the retention of seeds in the cells until deposited into the seed delivery system at the base of the meter. Typically, the metering rate is adjusted by changing the velocity ratio of the plate or by selecting a plate with more or less cells around its periphery. Seed metering performance is highly dependent on the use of graded seed and the match between the seed and cell sizes.

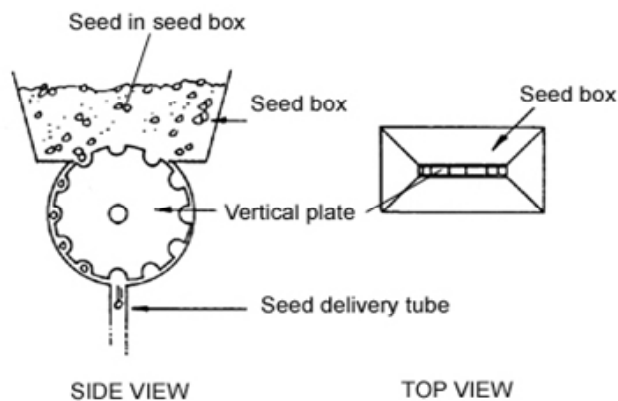

Figure 183: Side and top views of a typical vertical disc type seed meter

The width of the meter housing is usually fixed, so the overall width of the plate must remain constant, irrespective of the seed size. The plate is usually made up from a number of matched thinner plates of varying thickness to account for the seed size as well as the width of the plate chamber.

Figure 184 shows the top and side view of a vertical disc unit used in vegetable production. The top view shows the portion of the disc exposed to the seed while the side view shows the seed box, seed meter and the small runner type furrow opener. In the top view it can be seen that, in this case, the plate is a composite of two plates each of equal thickness and having the same cell dimension.

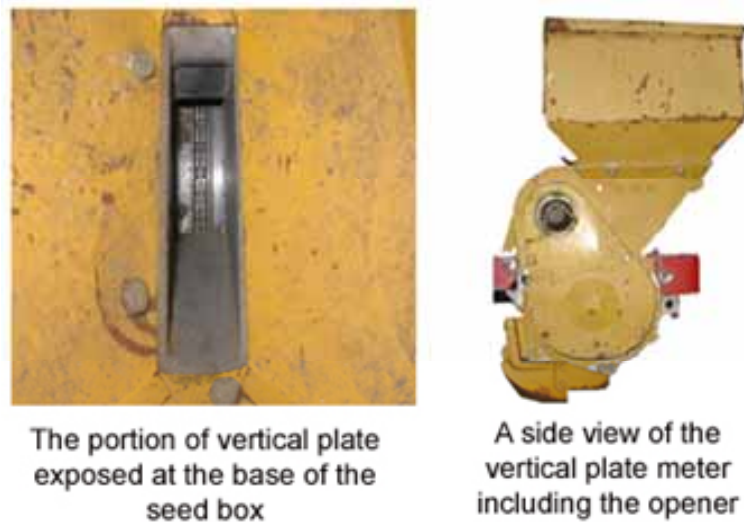

Figure 184: The top and side views of a vertical plate meter used for vegetable production

Air assisted vertical plate type precision seed meter

The air assisted vertical plate meter differs from other plate meters in that the plate has comparatively large, vented conical-shaped cells around its periphery and singulation is accomplished with the aid of a continuous jet of compressed air. The plate is fed externally just above its centreline and each of the cells is sufficiently large to hold a number of seeds (Figure 185). Before reaching the highest point of the plate, each cell is exposed to a jet of compressed air. This removes all but the one seed covering the vented section at the base of the inverted cone-shaped cells. The additional seeds removed from the cell simply fall back onto the surface of the seed lot. The single seed is conveyed to the outlet point at the base of the plate housing. A fixed ejector, running in the plate's vent groove and located at the base of the housing, is often used to ensure the individual seeds are ejected from the cell.

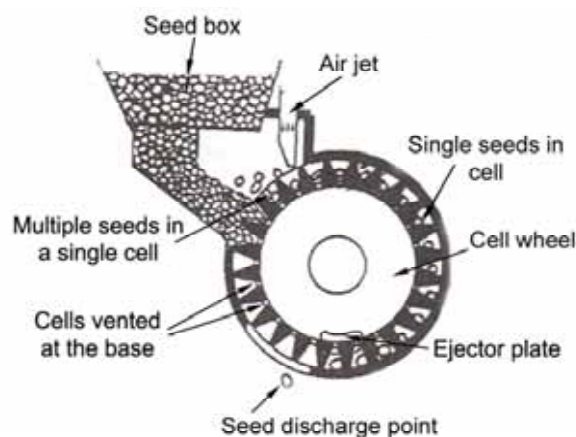

Figure 185: A cross-sectional representation of an air assisted vertical plate meter

Air assisted vertical plate meters have two major advantages over those relying solely on mechanical methods of singulation. First, they are better able to singulate irregular non-spherical shaped seeds (e.g. corn, sunflower, safflower, melon, etc) and, second, there is no requirement for graded seed. A single plate, with an appropriate fixed cell size, can handle the typical range of sizes within a given species.

Nevertheless, compared to other plate meters these meters are expensive to manufacture (because of the tolerances and degree of machining required to make the plates and housings, etc) and expensive to operate (because of the power requirements, etc, associated with the blower used to provide the supply of compressed air).

Figure 186 shows the exposure of the vertical plate at the base of the seed box (the compressed air jet removed) and the shape of a typical plate used in an air assisted vertical plate meter.

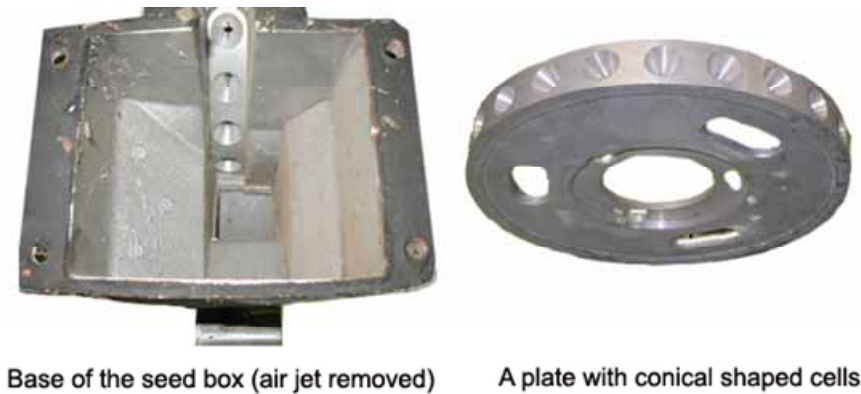

Figure 186: A view of the seed box base and plate from an air assisted vertical plate seed meter

Brush assisted plate type precision seed meter

Brush assisted vertical plate seed meters have a plate with a series of seed grooves around the periphery (Figure 187). The grooves have a cross-sectional area matched to the seed size but the groove is long enough to accommodate a number of seeds. The plate is fed internally from a seed chamber at the base of the plate, where the level of seed is adjusted and maintained by the position of a choke plate. A brush ring (not shown in Figure 187) with a continuous layer of short bristles is placed on top of the plate and fixed to the housing so that the bristles extend one seed width in from the edge of the plate around the top two-thirds of the plate. As the plate turns through the segment exposed to the seed, a number of seeds fall into the grooves. As it continues to move into the region of the brush only, the seed in the extremity of the groove is held in the groove by the brush; all the other seeds fall back to the seed lot.

The single seed in each groove is held by the brush until the plate moves to the discharge point where the brush terminates and allows the seed to fall into the seed delivery tube.

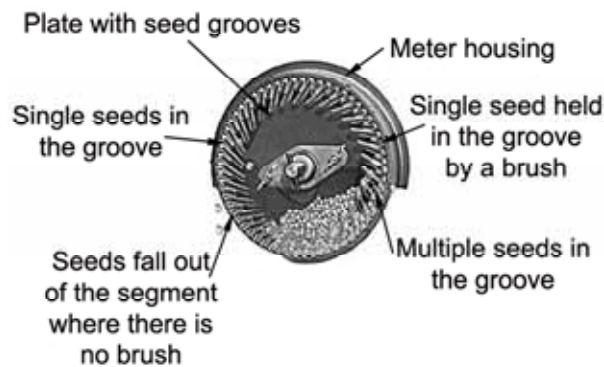

Figure 187: A cross sectional view of a brush assisted vertical plate meter

Figure 188 shows a more detailed view of the brush assisted plate meter's housing and plate. With the plate removed, the brush ring that extends about two-thirds the way around the circumference of the plate housing is visible. Further, the radially aligned outer portion of the seed groove, where the single seed is held by the brush, is visible on the enlarged view of the matching plate. The major advantages of the brush assisted vertical plate are design simplicity and the ability of the brush and groove combination to allow accurate metering without the need to use graded seed.

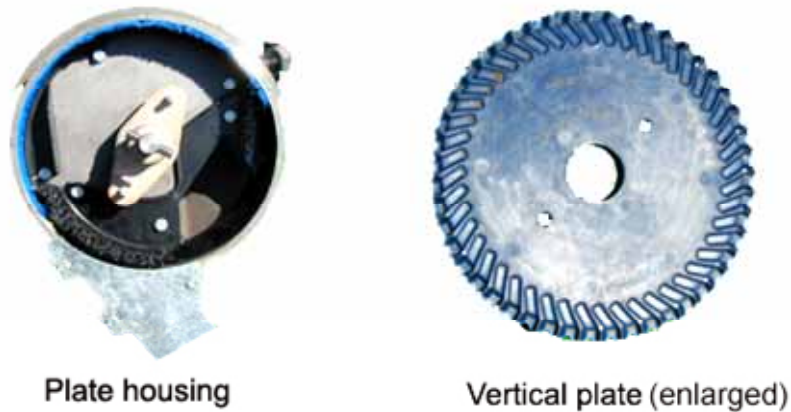

Figure 188: The housing and plate from a brush assisted vertical plate seed meter

Belt type precision seed meters

Belt type precision seed meters are similar to mechanical plate meters in the principle of operation but differ substantially in that the plate is replaced by a continuous rubberised belt of fixed width and thickness with holes, compatible to the seed size, equally spaced along its length.

As Figure 189 shows, seed falls from the seed box into the feed chamber where it is exposed to a portion of the belt. The amount or depth of seed in the chamber needs to be regulated to prevent choking or excessive wear on the mechanisms. The depth of seed required depends on the seed size and is adjusted by changing the size of the choke plate which partially covers the aperture between the seed box and the metering chamber. A stationary base plate, located under the belt along the length of the metering chamber, stops the seed falling through the belt.

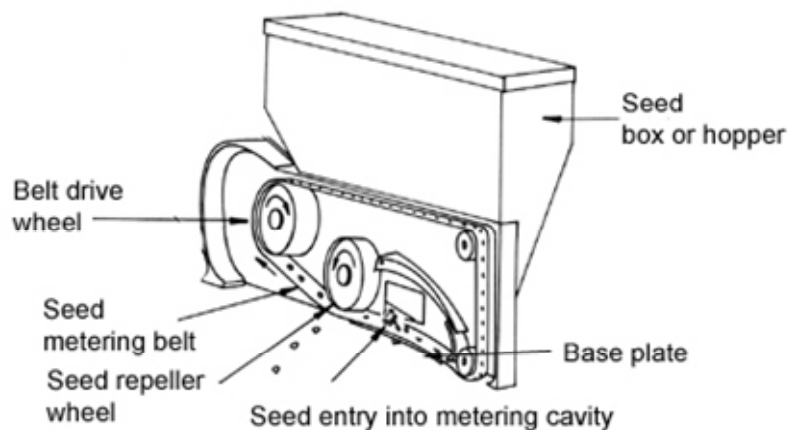

Figure 189: A diagrammatic representation of a typical belt type precision seed meter

As all belts have the same thickness, a particular combination of base plate and hole size is required for each different seed size, i.e. the combination of belt hole diameter, the thickness of the belt, and the depth and width of the groove in the base plate form a particular seed cell size.

Figure 190 shows the belt and base plate combination for a small, round seed with a thickness equal to the belt thickness (e.g. sorghum seed). Figure 191 shows the combination for a large, cylindrical seed (e.g. bean seed).

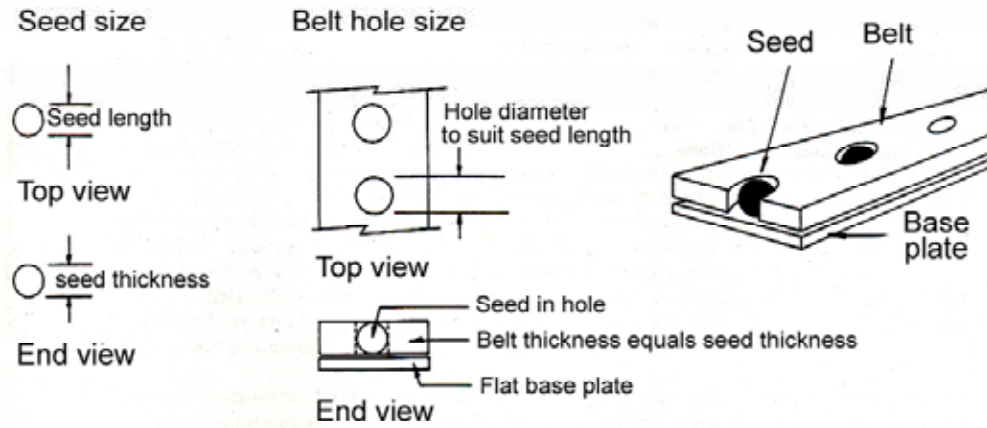

Figure 190: An example of the belt and base plate combination for a small round seed

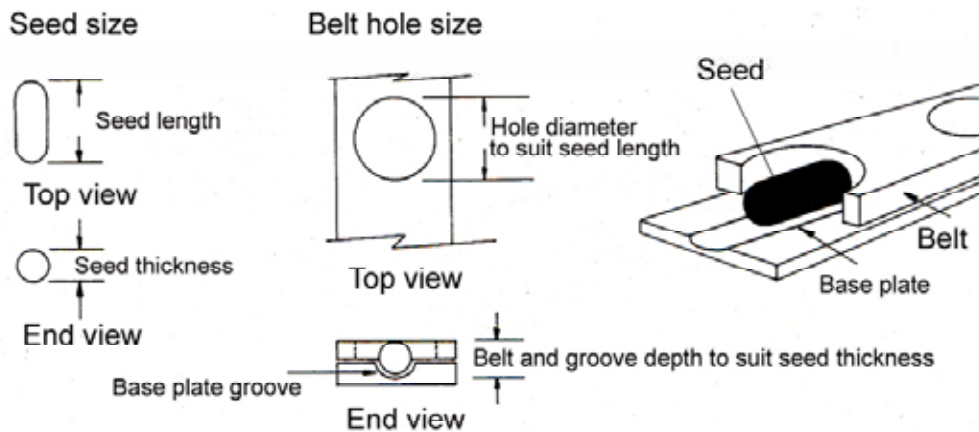

Figure 191: An example of the belt and base plate combination for a large cylindrical seed

The repeller wheel ensures that seed other than that fully enclosed in the cell remains in the metering chamber.

The accuracy of metering depends on similar criteria to that of other mechanical plate meters, i.e. uniformity of seed size, matching of cell size to seed size, and the speed of the belt. Metering rate is adjusted by altering the speed of the belt relative to ground speed and the number of holes per unit length of the belt. Incorrect matching of the cell and seed sizes increases the potential for seed damage during the metering process.

Figure 192 shows a side view of a belt type precision metering unit with the side and base plates removed. It also shows the metering belt from the same unit.

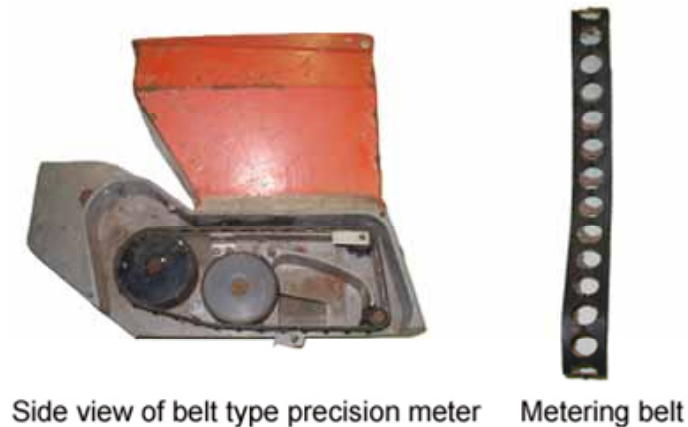

Figure 192: Side view of a belt type precision seed meter with the side plate removed

Vacuum disc type precision seed meters

The vacuum disc precision meter is now the industry standard, even though pressurised disc metering systems have been developed. Essentially, this system consists of a seed box, a split housing, a vertical rotating disc that has a row of holes around its circumference, and a fan or blower.

The disc differs from the plate used in plate type precision meters in that the seeds do not fall into, nor pass through, the hole and disc thickness plays no part in the singulation process. Further there is no need to correctly match the seed size to the hole size, other than ensuring the hole diameter is smaller than the smallest cross sectional dimension of the seed in the seed lot, i.e. small enough to ensure that seeds cannot pass through the hole.

As Figure 193 shows, the disc rotates between the two halves of the housing and is exposed to a negative pressure (vacuum) on one side and to the seed on the other. As the disc rotates, each hole passes through the seed lot and picks up one or a number of seeds as a result of the pressure difference across the disc, i.e. seeds are held by suction to the hole. As the disc continues to rotate, the seeds attached to a hole are subjected to the effects of a wiper that can be adjusted to cover more or less of the hole diameter. If the wiper is correctly adjusted all seeds except one will be wiped from each hole and fall back under gravity to the seed lot. The single seeds are then carried by the disc towards the base of the meter where the pressure difference is removed and the seed falls into the seed delivery system. The metering performance therefore depends mainly on a combination of the following:

- ensuring the disc hole size is the minimum required to prevent the smallest seed in the seed lot passing through, or being lodged in, the holes in the disc;
- selecting the correct pressure differential across the hole;
- setting the wiper/cutoff in the correct position to achieve singulation; and
- ensuring the disc speed does not exceed that required for seed pick-up/adhesion to the hole.

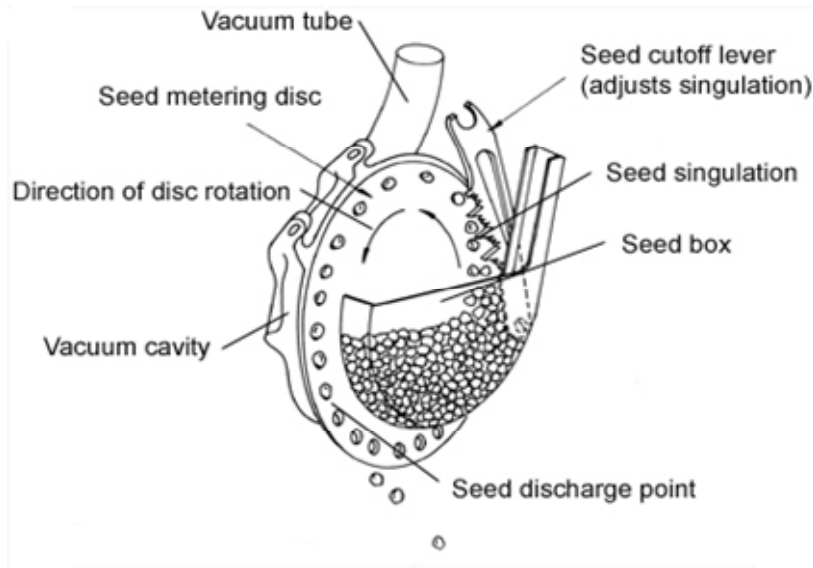

Figure 193: A diagrammatic representation of a vacuum disc type precision seed meter

The level of vacuum must be adjusted so that the pressure difference is sufficient to hold the seed to the plate but allow singulation by the cut-off wiper. Heavier seeds require a greater pressure difference. For a given seed, the smaller the hole diameter, the greater the pressure difference required. The setting of the wiper position is critical to metering performance. Incorrect setting results in either increased incidence of ‘doubles’ (two seeds per hole) or ‘misses’ (no seed per hole). Excessive disc speed reduces metering performance as it restricts the exposure time of each hole to the seed lot and increases the force required to hold the seed during the pick-up and singulation processes.

Because the seeds do not have to be precisely matched to the hole size, grading of seed is not an essential requirement, although still preferable for maximum accuracy of metering.

The seed metering rate is adjusted by changing the disc speed relative to ground speed and by selecting a disc with more or fewer holes around its circumference.

Figure 194 shows the side view of a vacuum disc metering unit delivering seed directly to the furrow through the rear cavity of a runner type opener and a plan view of a typical vacuum metering disc. The projections on the disc help agitate the seed in the metering chamber.



Side view of a vacuum disc seed meter



A vacuum seed meter disc

Figure 194: The side view of a vacuum disc metering unit and component disc

Pressurised drum type precision seed meters

While vacuum drum type precision seed metering systems are commonly used in seedling nurseries to plant seeds in trays, pressurised drum metering systems are more common in field crop production.

This type of precision seed meter typically consists of a seed box, a multi-row metering drum, a seed delivery manifold and a blower or fan unit to pressurise the drum and seed box and deliver the seed to the furrow. An open-ended drum is sealed to, but free to rotate on, a fixed end plate through which air and seed are delivered into the drum and through which seed exits the drum via delivery tubes (Figure 195). The drums of most metering units of this type have four or six rows of equally spaced holes around their circumference. As with vacuum disc types, the hole has to be smaller than the seed to be metered so a drum with the appropriate number of rows and size of holes has to be selected for each size to be planted.

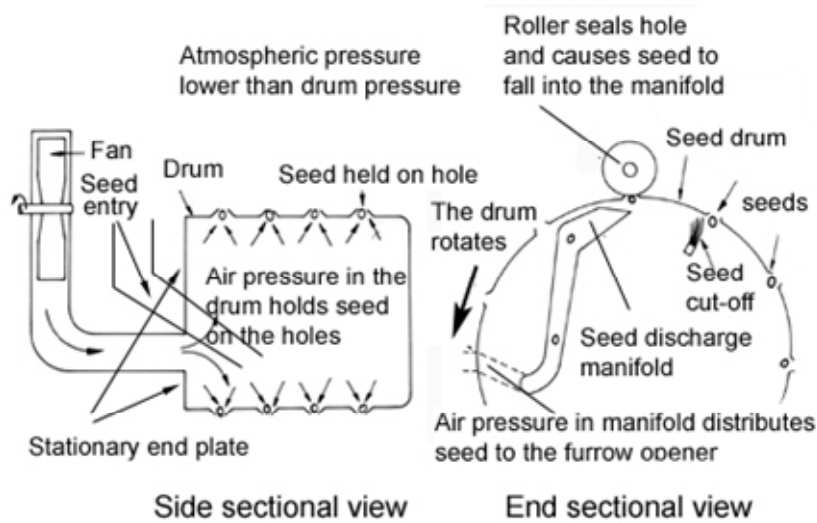

Figure 195: Sectional views of a pressurised drum type precision seed meter

Seed enters the drum from the seed box through a delivery chute that spreads it over the lower internal surface of the drum. As the drum rotates, one or two seeds adhere to, and are then carried by, the holes as they pass through the seed lot. Seed adhesion results from the pressure differential across the hole, i.e. the pressure inside the drum is higher than atmospheric pressure outside the drum. As the drum continues to rotate, the seeds pass a cut-off brush that causes all but one seed to remain on each hole; the excess seed falls back to the seed lot due to gravity. When the hole reaches its uppermost position, a roller positioned outside the drum blocks the hole, stopping the pressure differential, and the seed falls vertically into the seed discharge manifold.

Seeds falling into the discharge manifold enter a delivery tube where they are carried, by the air flow in the tube, to the furrow.

High metering performance relies on selecting the correct hole size and the optimum pressure setting for the particular seed type. For a given drum, the only means of adjusting the seeding rate is to change the rotational speed of the drum relative to ground speed.

Pressurised drum type precision seed metering systems are expensive to manufacture and have limited row capacity. This, together with the developments in, and the flexibility afforded by, for example, vacuum disc metering systems, has seen a decline in their popularity since the mid-1980s.

Figure 196 shows a pressurised drum seeding system used in conjunction with a rotary tiller.



Figure 196: A rear side view of a pressurised drum precision seed metering unit

Finger pick-up type precision seed meters

The finger pick-up (or plateless) precision seed meter (Figure 197) was initially developed in an attempt to overcome the inconvenience of having to change the hole size and hence the plate, disc or drum every time a different seed size was to be metered.

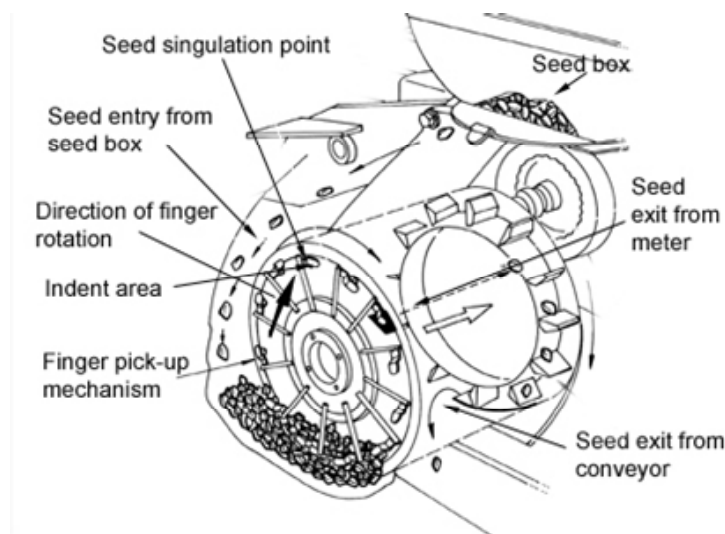

Figure 197: A diagrammatic representation of a finger pick-up type precision seed meter

Seeds fall from the seed box to the pick-up chamber in which a number of spring-loaded, cam-operated fingers rotate in a vertical plane. As the fingers move towards the base of the chamber, the cam causes the individual finger bars to rotate so that the finger's leading edge lifts away from the stationary backing plate. As it moves through the seed lot, the cam allows the finger to close so that it traps one or more seeds between it and the backing plate. Trapped seeds are elevated from the seed lot and pass over two indented areas on the backing plate, where singulation occurs. The single seed remaining in the finger is deposited through a hole towards the top of the backing plate into a conveying system. This maintains the seed spacing until it is deposited into the seed delivery system at the base of the meter.

Figure 198 shows the method of singulation (the indent section of the backing plate is viewed from above). It shows the progression of a finger as it moves from left to right along the backing plate. As the spring-loaded, cam-controlled finger closes onto the backing plate prior to passing out of the seed lot

three seeds (in this case) are trapped, held and moved upwards along the backing plate until it approaches the first indent as shown in Position 1 where the first (and perhaps the second) seed is released and allowed to fall vertically downwards back to the seed lot.

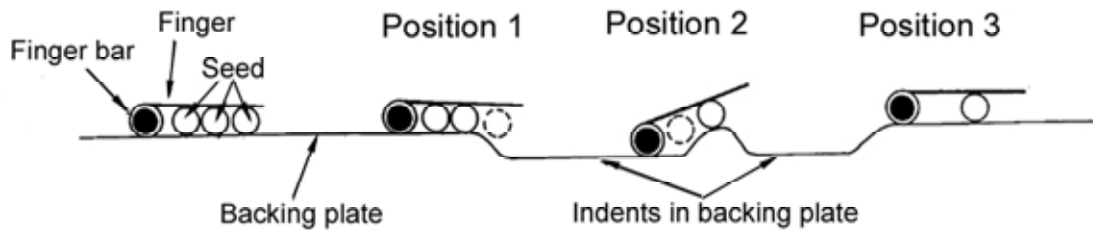

Figure 198: The singulation process used on finger pick-up type precision seed meters

The seed is released because the finger position is dictated by the remaining seed or seeds. Other opportunities for singulation occur as the finger leaves the first indent and when it enters and leaves the second indent. For example, in Position 2 the finger is leaving the first indent position with two seeds under the finger. Here, there is an opportunity for the second seed to be released because the finger position is dictated by the leading seed as it reaches and is pushed up the incline. By the time the finger exits the second indent, only one seed remains under each finger as shown in Position 3.

Figure 199 shows the form of a typical finger pick-up type precision meter. A portion to the external cover has been removed to show the fingers, the indent section of the backing plate and the hole in the backing plate through which the seed is deposited to the elevator section.



Figure 199: An example of a finger pick-up type precision seed meter

Changing the speed of the fingers' rotation relative to ground speed is the sole means of changing the seeding rate on this type of seed meter.

While the finger pick-up meter continues to be used for the metering of large, ungraded seed lots of, for example, maize and sunflower it is anticipated that it, along with most other precision metering types, will be replaced by a vacuum disc type in the longer term.

7.4 Selection of seed meter type

No one seed metering system can meet the requirements of all crop types. Compromises have to be made and, in many cases, at least two planting machines will be required – one for drill planting and one for precision planting, particularly where both summer and winter cropping is undertaken.

Irrespective of the cropping program, an informed decision can only be made if the following information is known for each of the crops to be planted:

- the established population required and the expected levels of both germination and field emergence;
- the range of agronomically acceptable row spacings;
- the sensitivity of crop yield to the evenness of plant spacing along the row; and
- the physical properties of the seed: seed size and variation in seed size, seed shape and seed fragility in particular.

While all seed meter types will find a role because of simplicity, cost, flexibility in drive mechanism, ease of adjustment or cleaning, etc, it is anticipated that in the longer term ‘peg or studded roller’ types and ‘vacuum disc’ types will predominate for use in drill and precision planting systems, respectively.

SECTION 8

Planter seed delivery components

Seed delivery systems include those devices that convey the seed from the meter to the device that deposits the seed on the soil surface or in the furrow.

8.1 Functional requirements of seed delivery systems

The essential *functional requirements* of seed delivery systems are to:

- convey the seed from the seed meter discharge point to the seed placement device;
- maintain metering accuracy (seed spacing) during seed conveyance; and
- enable the seed to be deposited on the soil surface or in the furrow in an appropriate manner in terms of both seed placement within the furrow and seed spacing along the row.

Ideally, the seed delivery system should deposit the seed on the firm, moist base of the furrow (unless required otherwise for a specific reason). The spacing of seeds along the furrow should be proportional to that at time of seed metering.

8.2 Operational requirements of seed delivery systems

To meet their functional requirements, the *operational requirements* of seed delivery systems differ somewhat, depending on the type of seed metering system used.

On drill planters, where mass flow seed metering systems are typically used, the design of the seed delivery system has little influence on the overall outcome, provided seed flow through the system is not unduly impeded and that the exit velocity is low enough to ensure seeds are placed on the furrow base rather than adjacent to, or on the side walls of, the furrow because the seed has bounced or otherwise been displaced when it came in contact with the soil.

On precision planters, the design of the delivery system is particularly important because a functional requirement is to translate seed metering accuracy (i.e. the uniformity in the time interval between individual seeds metered) to placement accuracy (i.e. the uniformity of seed spacing along the furrow or row). To achieve this, the typical operational requirements of the delivery tube, where used, are that they:

- are as short, straight and rigid as possible;
- have the smallest adequate cross-sectional area;
- have a smooth interior surface; and
- terminate, where possible, with a rearward deflection.

While the reasons for having short, straight, rigid delivery tubes with a smooth interior and appropriate cross section are obvious, the reason for having the tube terminate with a rearward deflection is often not understood. To prevent seeds bouncing or rolling on contact with the soil, their true exit velocity should, ideally, be small and vertical, i.e. having a zero component in the direction of machine travel. This can only be achieved if the seeds leave the delivery system with a rearward velocity similar to the forward velocity of the machine.

The advantages of these operational requirements have to be balanced against their implications for both crop yield and overall machine design. Placing the precision metering system close to the furrow will improve the prospects for uniformity of seed spacing along the furrow, but may, for example, reduce the residue-handling ability of the machine or increase the rate component wear due to higher dust levels, etc.

8.3 Types of seed delivery systems

Most delivery systems can be broadly classified as:

- gravity drop;
- mechanical assist; or
- pneumatic.

8.3.1 Gravity drop seed delivery systems

In a gravity drop delivery system, the seed simply falls through a cavity or a tube from the seed meter to the soil. Where precision metering systems are used and soil surface residue conditions permit, the seed meter is usually placed as close as possible to the soil surface to reduce the length of the delivery tube required. Figure 200 shows a vacuum disc seed metering system close coupled with a runner type furrow opener. The seed falls through the split cavity of the runner opener to the base of the furrow.



Figure 200: Seed delivery by gravity drop through the rear, split cavity of a runner opener

Figure 201 shows a gravity drop seed delivery system using a short dropper tube to convey the seed from a vacuum disc seed metering system to the furrow via the split cavity at the rear of a small runner type furrow opener.



Figure 201: Seed delivery by gravity drop through a short dropper tube

Figure 202 shows a gravity drop seed delivery system using a long, rigid, dropper tube with a rearward deflection to convey seed from a precision meter to a single disc type furrow opener.



Figure 202: Seed delivery by gravity drop through a tube terminating with a rearward deflection

Where gravity drop seed delivery systems are used in conjunction with mass flow seed metering systems, the length and shape of the dropper tube is less important, provided seed flow is not unduly impeded. Figure 203 shows the typical gravity drop delivery system used on drill planters to convey seed from a mass flow type meter to the furrow.



Figure 203: Seed delivery by gravity drop through long dropper tubes on drill type planters

8.3.2 Mechanically assisted seed delivery systems

Mechanically assisted seed delivery systems incorporate a mechanical device to assist in the delivery of seed from the seed meter to the seedbed. Typically, they can be categorised as either:

- spinning discs or oscillating spout types, as commonly used on broadcast planters to assist spread seed over an appropriate width of the seedbed surface; or
- conveyor types, as used on precision seeders to assist in maintaining metering accuracy (seed spacing) between the meter and the furrow.

While these systems remain an integral component on most broadcast planters, they are now rarely used on precision type planters. This is primarily because improvements in plant breeding, seed harvesting and seed storage have reduced the need for hill drop and check row planting patterns where mechanical delivery systems often played an important role.

Spinning disc type

Figure 204 shows a broadcast type planter incorporating a spinning disc type system of mechanically assisted seed delivery. The disc has a number of fixed vanes radiating from its central portion. Seed falls from a stationary opening type seed meter directly onto the spinning disc. It is then spread out, or broadcast, over a given width of the seedbed surface.



Figure 204: Spinning disc type mechanically assisted seed delivery system

Oscillating spout type

Figure 205 shows a broadcast planter with an oscillating spout type mechanical assisted delivery system. The seed is metered by a stationary opening type mass flow seed meter directly into the entry of the oscillating spout. As the spout oscillates backwards and forwards at speed, the seed is accelerated towards the discharge end of the spout and broadcast over the seedbed surface in an arc. The width of the arc can be adjusted by altering the extent to which the spout can travel in one oscillation.



Figure 205: Oscillating spout type of mechanically assisted delivery system

The seeding rate is not uniform over the full width resulting from a single pass of a planter using a spinning disc or oscillating spout type delivery system. In general, the rate is higher in the central portion and tapers to zero at the extremity of the arc. Overlapping the arcs in subsequent passes provides for a more uniform planting rate over the entire seedbed surface.

Conveyor type

Figure 206 shows a mechanical delivery system incorporating a seed conveyor enclosed in the furrow opener standard. The conveyor maintains seed spacing as the seed is mechanically conveyed from the horizontal plate type precision meter to the furrow opener (not shown).

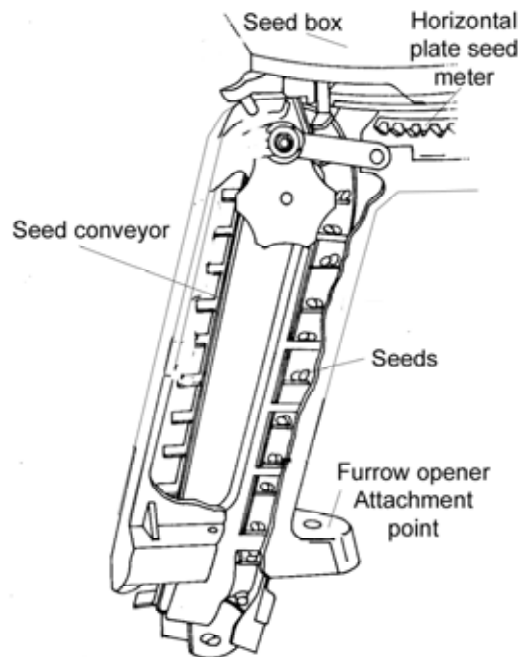

Figure 206: An example of a conveyor type mechanically assisted delivery system

Conveyor type mechanically assisted delivery systems are rarely used today because of their cost and complexity and a general improvement in gravity drop delivery systems. Nevertheless, a similar concept is still used on, for example, finger pick-up type precision seed meters to maintain seed spacing from the point of discharge from the seed meter to the base of the seed metering mechanism (Figure 197).

8.3.3 Pneumatic seed distribution and/or delivery systems

Pneumatic seed delivery systems are typically used on multi-row planters fitted with a single centrally located seed box. The seed is metered into a delivery tube where it is conveyed by an air stream to individual furrow openers that are uniformly spaced across the full width of the machine. Pneumatic seed delivery systems can be sub-classified into two general types:

- those designed for seed ‘delivery only’; and
- those designed for seed ‘delivery and division’.

Pneumatic 'delivery only' systems

In 'delivery only' systems the seed is metered directly into the tube that delivers it to the furrow by air flow in the tube. In Figure 196, a drum type seed metering system feeds seeds into individual tubes that convey the seeds to their respective furrow opener. Figure 207 shows the essential components of the more typical arrangement, where each meter, positioned under a common, centrally located seed box, delivers seed to a tube that pneumatically conveys it to the furrow opener. In this case, the blower has a four-way manifold that supplies air to four individual tubes. Individual seed meters are assigned to each tube and each tube delivers seed directly to the opener.

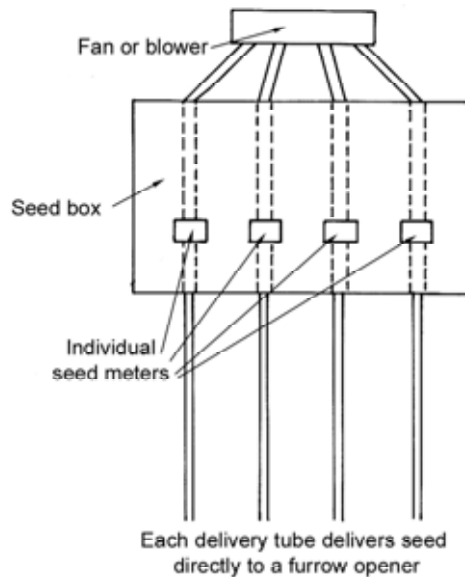

Figure 207: The components of a 'delivery only' type of pneumatic seed delivery system

Pneumatic 'delivery and division' systems

Pneumatic delivery and division systems form the basis of the so-called 'air seeders' which are available as discrete machines or as a planting attachment for tined tillage equipment, such as chisel ploughs, scarifiers and cultivators.

There is considerable variation in design, but seed for all or a number of furrow openers (typically three to nine) is metered into a single tube where it is conveyed pneumatically to a 'dividing head'. The dividing head divides the airstream (and hence the seed) equally into a number of outlets located symmetrically around the head, each outlet delivering seed directly to an opener or a secondary head where the process is duplicated.

Figure 208 shows the typical layout for a delivery and division system using a primary dividing head only.

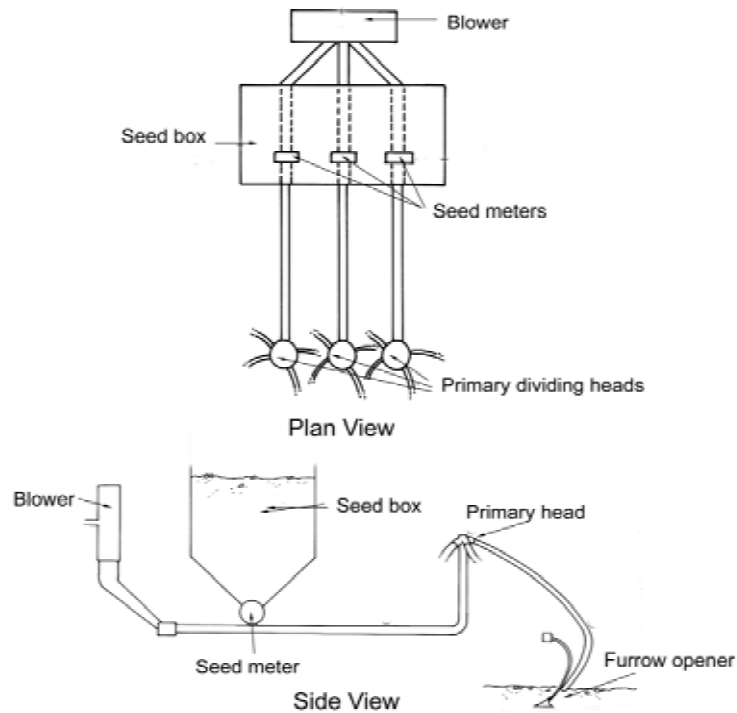

Figure 208: A pneumatic delivery and division system utilising primary heads only

The system shown in Figure 208 consists of a single seed box with three mass flow type seed meters located under the box. Each seed meter delivers seed to an airstream that is subsequently divided by a four outlet primary head, each outlet delivering seed to four individual furrow openers. Typically, using a primary head only, a single seed meter can supply up to nine openers.

Figure 209 shows a system utilising both primary and secondary dividing heads.

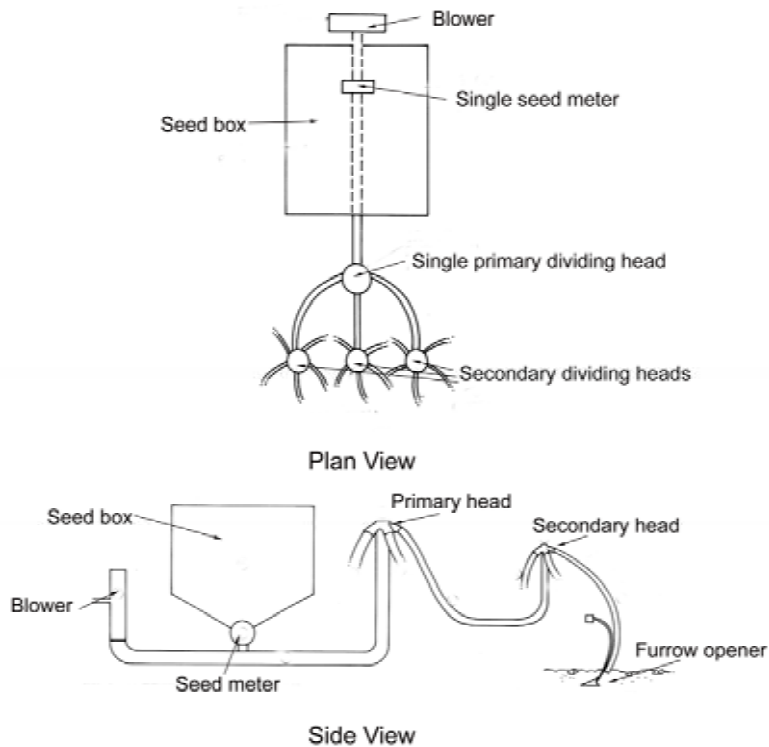

Figure 209: A pneumatic delivery and division system utilising primary and secondary heads

The system in Figure 209 consists of a single, large seed box supplying seed to a single, high volume mass flow type of seed meter. This meter delivers seed to an airstream that is subsequently divided by both primary and secondary heads such that the single meter delivers seed to a total of 16 individual openers. Typically, using this system of primary and secondary heads a single seed meter can supply up to 81 individual furrow openers.

A large range of dividing heads is available for use in pneumatic delivery and division systems. The diversity in designs precludes detailed discussion on the types and their relative operational and performance characteristics. They can range from simple cast or moulded types without any moving elements (Figure 210) to complex, fabricated systems incorporating driven components (Figure 211).



Figure 210: A simple moulded plastic dividing head



Figure 211: Seed and fertiliser heads incorporating hydraulically driven components

The system in Figure 211 incorporates separate seed and fertiliser dividing heads. Both have rotating elements fixed to a common, hydraulically driven, vertical shaft.

All planters using pneumatic delivery and/or division systems require a way to isolate the seed meter from the effects of pressure in the airstream because any air flowing back through the meter can seriously impair metering performance. There are three general systems of loading the air stream with seed (and/or fertiliser) (Figure 212):

- the pressurised box system;
- the venturi system; or
- the air lock or rotary valve system.

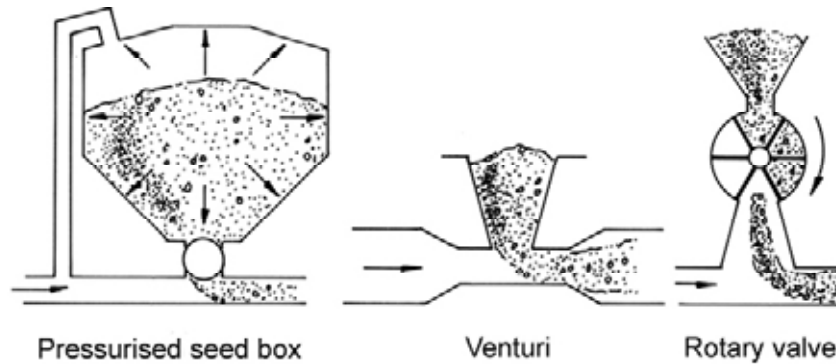

Figure 212: Common methods used to load the airstream

In the pressurised box system, a hose or pipe from the fan outlet is connected to the seedbox. If the seed box is sealed, then the pressure inside the box is equal to that in the seed delivery pipe. With equal pressure above and below the seed meter, seed falls by gravity into the delivery airstream and there is no blowback through the meter to impair its performance. While the lids, etc, on the seed box need to be fully sealed when the machine is operating, the system is relatively simple and requires no additional moving parts. Any air leak in the seed box may, however, allow a pressure difference to develop and impair metering performance.

The venturi system is simple in design and trouble-free in operation. As the air enters the tapered section on the upstream side, the air velocity is increased, causing a pressure reduction to the extent there is no back pressure and the seed falls freely under gravity into the airstream. The seed box does not have to be sealed and no additional moving parts are required.

The rotary valve or air-lock system isolates the meter from the pressurised airstream in the delivery tube and discharges the seed into the airstream as it rotates. The rotary valve has to be of an adequate size to cope with the volume of seed to be metered and its sealing surfaces have to be well maintained to ensure effective operation. One disadvantage of this system is the need for additional moving parts.

While the air flow rate needs to be adequate to reliably convey the seed to the furrow opener, rates in excess of those required for delivery should be avoided. Higher rates increase seed velocity in the delivery tubes and can cause the seed to bounce or otherwise be displaced from the base of the seed furrow. Some air planters have a diffuser or expansion chamber close to the seed placement device to reduce seed velocity immediately before the seed is placed in the furrow.

In general, pneumatic systems designed to deliver and divide seed are only used on drill type planters using mass flow metering systems. While many factors influence the overall performance of these systems, it is generally agreed that if they are appropriately designed, set and maintained, their performance compares favourably with traditional drill planters that use a single seed meter and a gravity drop distribution system for each opener.

Figure 213 shows the typical layout of a cultivator-based planter using a pneumatic seed delivery and division system incorporating both primary and secondary heads. A single seed meter supplies seed to a five-outlet primary head. Each outlet from the primary head is directed into an eight-outlet secondary head. Each outlet from a secondary head supplies one furrow opener. Using this system the single seed meter supplies 40 individual furrow openers.

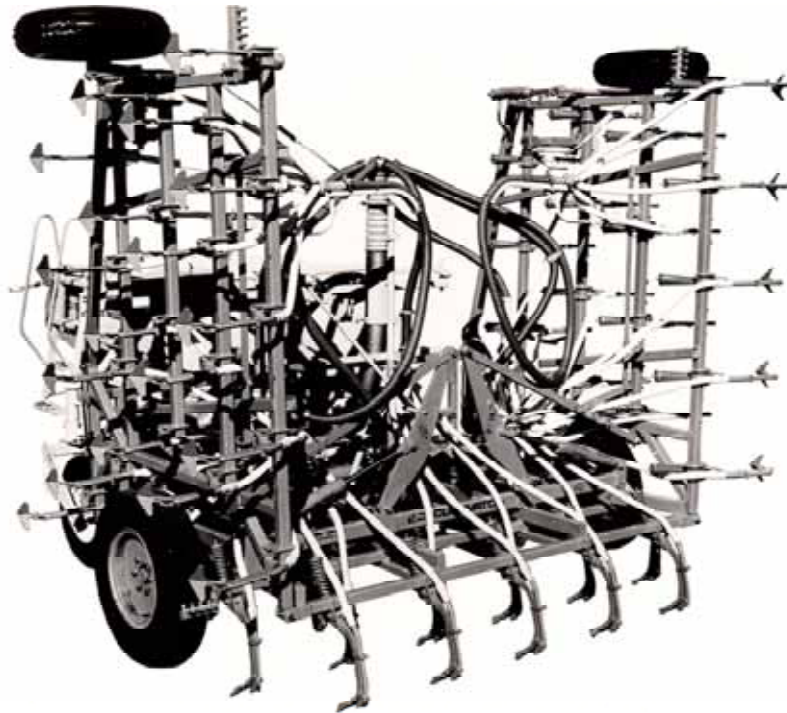

Figure 213: An example of a pneumatic seed delivery and division system

Considerable research has been directed towards identifying the parameters that influence the uniformity of planting rate resulting from the use of pneumatic delivery and/or distribution systems. Symmetry in the dividing heads and uniformity in the back pressure or resistance to air flow to each opener appear to be the major determinants, apart from having adequate air velocity to convey the seed through the tubes. Centralising the seed in the air stream by, for example, using a straight section of pipe with a convoluted wall section immediately prior to the dividing head is also considered beneficial. The use of air velocities in excess of that required to convey the seed through the tubes should be avoided because of the potential to induce seed bounce at the time of delivery to the furrow. Expansion chambers or similar means to reduce air, and hence seed, velocity immediately prior to discharge into the furrow are commonly used to reduce the potential for seed bounce while ensuring adequate velocity for seed conveyance throughout the delivery system.

SECTION 9

Examples of planter description

Having classified a planter (using the process set out in Section 3) it may be more fully described by providing, where appropriate/applicable, detail of its:

- soil-engaging components (i.e. soil and residue cutting device; row preparation device; furrow opener; seed firming device; seed covering device; row specific seed firming device and non row specific seed firming/levelling device);
- furrow opener depth control mechanism (i.e. frame section gauging or types within individual row gauging systems);
- seed metering (i.e. specific types within mass flow or precision metering systems); and
- seed delivery and/or division system (i.e. types within gravity drop, mechanical assisted or pneumatic delivery/division systems).

9.1 Example 1 – A broadcast planter



Figure 214: A broadcast planter

The planter in Figure 214 has been previously classified as a hand-held, human-powered broadcast planter.

This planter has no soil-engaging or depth control components. Nevertheless, it does have a sliding plate stationary opening type seed meter and a spinning disc type seed distribution system.

Therefore, the planter could be classified and fully described as a hand-held, human-powered broadcast planter equipped with the following components:

- a sliding plate stationary opening type mass flow seed metering device; and
- a spinning disc type mechanically assisted seed delivery device.

9.2 Example 2 – A drill planter

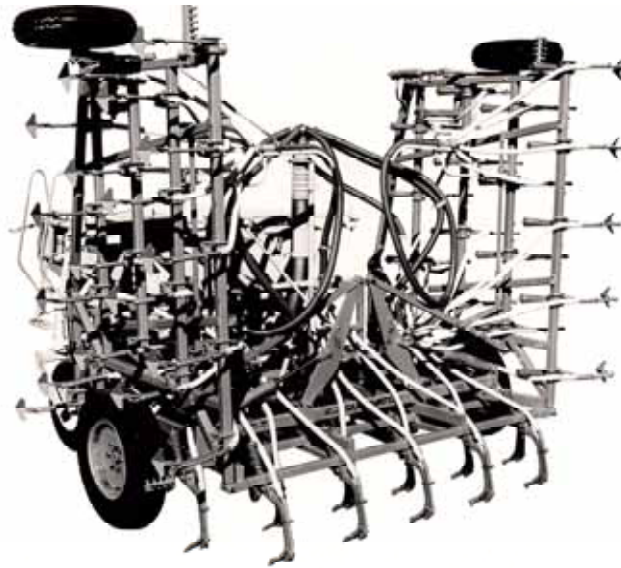

Figure 215: A drill planter

The drill planter in Figure 215 can be classified and fully described as a 40-row, trailed, tractor-powered drill planter equipped with the following components:

- a duckfoot dual purpose tine type furrow opening device;
- a flexible type frame section gauging furrow opener depth control device;
- a fluted roller external force feed type mass flow seed metering device; and
- a primary and secondary head, delivery and division type pneumatic seed delivery device.

9.3 Example 3 – A precision planter



Figure 216: A precision planter

The precision planter in Figure 216 can be classified and fully described as a 6-row (not shown), rear-mounted, tractor-powered precision planter equipped with the following components:

- aligned double finger wheel type row preparation device;
- aligned twin inclined double disc coulter type furrow opening device;
- aligned twin inclined press wheel type row specific seedbed firming device;
- dedicated gauge wheel, parallelogram type furrow opener depth control device;
- a vacuum disc type precision seed metering device; and
- a plastic tube type gravity drop seed delivery device.

9.4 Example 4 – A dibble planter



Figure 217: A dibble planter

The dibble planter in Figure 217 can be classified and fully described as an 8-row, rear-mounted, tractor-powered dibble planter equipped with the following components:

- a punch type furrow opening device;
- a rigid frame section gauging type furrow opener depth control device;
- a fluted roller external force feed type mass flow seed metering device; and
- a spiral metal tube type gravity drop seed delivery device.

SECTION 10

Planter classification and description keys

Used in combination the keys that follow allow for the broad classification and detailed description of planting machinery in a consistent and meaningful way. The keys are derived from the information contained in the preceding sections. In both keys the classification or description is formulated by reading from right to left, i.e.:

- number of rows, mounting option, mounting, power source then type, in the case of classification; and
- options, type, then device, in the case of description.

A key for planter classification

Type of Planter	Power Source	Mounting	Mounting Options	Number of Rows	
Broadcast or Drill or Precision or Dibble	Human	Hand held		As Applicable	
		Hand pushed			
		Hand pulled			
	Animal	Pulled			
		Trailed			
	Tractor	Semi mounted			
		Mounted	Rear		
			Mid		
					Front

A key for planter description

Component	Device	Type	Options		
Soil Engaging Components	Soil and Residue Cutting Device	Disc Coulter	<ul style="list-style-type: none"> Plain Notched Bubble Ripple Fluted Wavee Turbo 		
				Blade	
	Row Preparation Device	Finger Wheel	<ul style="list-style-type: none"> Single Double 	<ul style="list-style-type: none"> Aligned Staggered 	
					Concave Disc
		Finger Harrow	<ul style="list-style-type: none"> Single Finger Multiple Finger 		
				Tine	<ul style="list-style-type: none"> Sweep Point
		Roller			
		Horizontal Disc			

Continued

A key for planter description (continued)

Group	Device	Type	Options				
Soil Engaging Components (Continued)	Furrow Opening Device	Runner	}	Full Stub			
		Concave Disc					
		Disc Coultter	}	Single	}	Aligned Single Angle Compound Angle	
				Double		}	Twin Inclined
				Triple	}		One Vertical, One inclined
		Tine	}	Dedicated		}	Point Blade Inverted "T"
					Shoe		Near Vertical Forward Curved Rearward Curved
		Dual Purpose	}	Point Duckfoot Sweep			
Bioblade							
Powered							
Punch							

Continued

A key for planter description (continued)

Group	Device	Type	Options	
Soil Engaging Components (Continued)	Seed Firming Device	Slide		
		Wheel		
	Seed Covering Device	Chain	{	Loop Trailing With bar
		Concave Disc	{	Single Double
		Disc Coulter	{	Single Double
		Knife	{	Single Double
		Paddle	{	Single Double
		Tine	{	Single Double
		Finger	{	Single Double
		Finger wheel	{	Single Double

Continued

A key for planter description (continued)

Group	Device	Type	Options	
Soil Engaging Components (Continued)	Row Specific Seed Bed Firming Device	Presswheel	Over-Centre { Flat Wedge Ribbed	
			Zero-Pressure { Plain Ribbed Split packer	
			Inclined { Single Twin { Aligned Staggered	
		Finger wheel	Single	{ Aligned Staggered
			Double	
	Coil press			
	Non Specific Seed Bed Firming / Levelling Device	Roller	{ Wooden Metal Tyre	
		Packer	{ Spiral Cage Roller Toothed Disc	
		Harrow	{ Peg Leaf Chain Rotary { Rigid Flexible	

Continued

A key for planter description (continued)

Group	Device	Type	Options
Furrow Opener Depth Control	Frame Section Gauging Furrow Opener Depth Control Device	Rigid Frame	
		Flexible Frame	
	Individual Row Gauging Furrow Opener Depth Control Device	Parallelogram	<ul style="list-style-type: none"> ⎵ Rear Wheel ⎵ Dedicated Wheel ⎵ Front Wheel ⎵ Twin Wheels
		Trailing Arm	<ul style="list-style-type: none"> ⎵ Rear Wheel ⎵ Dedicated Wheel ⎵ Twin Wheels
Seed Metering Devices	Mass Flow Seed Metering Device	Stationary Opening	<ul style="list-style-type: none"> ⎵ Sliding Plate ⎵ Rotary Plate
		Internal Force Feed	
		External Force Feed	<ul style="list-style-type: none"> ⎵ Fluted Roller ⎵ Peg/Studded Roller
	Precision Seed Metering Device	Plate	<ul style="list-style-type: none"> ⎵ Mechanical Horizontal ⎵ Mechanical Inclined ⎵ Mechanical Vertical ⎵ Air Assisted Vertical ⎵ Brush Assisted Vertical
		Belt	
		Vacuum Disc	
		Pressurized Drum	
Finger Pickup			

Continued

A key for planter description (continued)

Group	Device	Type	Options
Seed Delivery	Gravity Drop Seed delivery Device	No Tube	
		Metal Tube	
		Plastic tube	
		Rubber tube	
	Mechanically Assisted Seed Delivery Device	Spinning Disc	
		Oscillating Spout	
		Elevator	
	Pneumatic Seed Delivery Device	Delivery Only	
		Delivery and Division	<div style="display: flex; align-items: center;"> <div style="font-size: 2em; margin-right: 5px;">}</div> <div> <p>Primary Head</p> <p>Primary and Secondary Head</p> </div> </div>

Conclusion

This book attempts to describe and define terminology for all components of the wide range of planting equipment seen by the authors over many years experience, primarily in Australia, but also in China, the United States and Europe. It also includes a small number of units known only from reports in the literature. It attempts compatibility where possible with existing, related 'standard' information, such as that provided in the various standard documents by ASAE (2005).

This is the first attempt at such a comprehensive approach to a serious problem, and every effort has been made to cover all known equipment variations. Inevitably, there will be some omissions. The authors welcome information on units that cannot be categorised or described using the system so that appropriate updates or additions can be made.

SECTION 12

Further information

http://www.wantfa.com.au/	Western Australian No-tillage Farmers Association
http://www.santfa.com.au/	South Australian No-till Farmers Association
http://www.vicnotill.com.au/	Victorian No-till Farmers Association
http://www.cfi.org.au/	Conservation Farmers Inc
http://www.ifao.com/Notillbook/notillbooklist.htm	List of books on conservation tillage / no-till / direct seeding / zero-tillage
http://www.grdc.com.au/growers/gc/gc58/notill.htm	Grains Research and Development Corporation article
http://www.istro.org	International Soil Tillage Research Organisation
http://www.ctfsolutions.com.au	Controlled Traffic Farming website
http://www.fao.org/ag/ags/aGSE/agse_e/general/CONT1.htm	FAO conservation agriculture background
http://www.fao.org/ag/catd/index.jsp	FAO technology database

SECTION 13

Bibliography

- ASAE (2005). Manual of Standards, Engineering Practices and Data. American Society of Agricultural Engineers, St Joseph.
- Abernathy, G. H. and J. G. Porterfield (1969). Effect of planter opener shape on furrow characteristics. *Trans. ASAE.*, **1**:16–19.
- Adam, N. M., McDonald M. B. and P. R. Henderlong (1989). The influence of seed position, planting and harvesting dates on soybean seed quality. *Seed Sci. & Technol.*, **17**:143–152.
- Agness, J. B. and H. J. Luth (1975). Planter evaluation techniques. ASAE Paper No., 75–1003. Am. Soc. Agr. Eng., St Joseph, MI.
- Asher, C. J. (1987). Crop nutrition during the establishment phase: role of seed reserves. In: I. M. Wood, W. H. Hazard and F. R. From (Editors), *Crop Establishment Problems in Queensland: Recognition, Research and Resolutions*. Occas. Publ. No., 34, Australian Institute of Agricultural Science, Brisbane, Qld.: 88–106.
- Awadhwal, N. K. and G. E. Thierstein (1985). Soil crusts and its impact on crop establishment: A review. *Soil & Tillage Res.*, **5**: 289–302.
- Baker, C. J. (1976). Experiments relating to techniques for direct drilling of seeds into untilled dead turf. *J. Agric. Engng. Res.* **21**:133–144.
- Baker, C. J. (1977). Testing and development of direct-drilling equipment for dry soils. Proc. International Conf. on Energy Conservation Crop Production, Massey University, New Zealand, 205–213.
- Baker, C. J. (1993). Zero-tillage gets the go-ahead. *Farming Ahead* (17):15,17.
- Benjamin, L. R. (1990). Variation in time of seedling emergence within populations: A feature that determines individual growth and development. *Adv. in Agron.* **44**:1–25
- Bewley, J. D. and M. Black (1982). Physiology and biochemistry of seeds in relation to germination. Vol. 2. Springer-Verlag: Berlin.
- Blacket, D. S. (1987). Improving crop emergence with management and agronomy. In: I. M. Wood, W. H. Hazard and F. R. From (Editors), *Crop Establishment Problems in Queensland: Recognition, Research and Resolutions*. Occas. Publ. No. 34, Australian Institute of Agricultural Science, Brisbane, Qld.: 192–207.
- Bligh, K. and A. Stone (1993). Cross Slot shows its worth. *Farming Ahead*, **21**:18
- Braunack, M. V. and A. R. Dexter (1989). Soil aggregation in the seedbed: a Review. 2. Effect of aggregate sizes on plant growth. *Soil & Tillage Res.* **14**: 281–298.
- Brennan, P. S. and R. J. Henry (1987). Breeding strategies for the amelioration of crop establishment problems. In: I. M. Wood, W. H. Hazard and F. R. From (Editors), *Crop Establishment Problems in Queensland: Recognition, Research and Resolutions*. Occas. Publ. No. 34, Australian Institute of Agricultural Science, Brisbane, Qld.: 107–119.
- Brocklehurst, P. A. (1985). Factors affecting seed quality in vegetable crops. *Scientific Horticulture*, **36**: 48–57.
- Brown, N. J. (1970). The influence of cultivation on soil properties. *J. Ins. Ag. Eng.*, **25**, (3): 112–114.
- Bucher, D. H., Hitzhusen, T. E. and D. T. Sorlie (1975). John Deere power-till seeder. ASAE Paper No., 75–1591. Am. Soc. Agr. Eng., St Joseph, MI.
- Campbell, A. J. and C. J. Baker (1989). An x-ray technique for determining three-dimensional seed placement in soils. *Trans. ASAE.*, **32**, (2):379–384.
- Cannell, R. Q. and M. B. Jackson (1981). Alleviating aeration stresses. In: G. F. Arkin (Editor), *Modifying the Root Environment to Reduce Crop Stress*, ASAE. Mon. No 4., Am. Soc. Ag. Eng., St Joseph. Mich: 141–192.
- Carter, O. (1969). Effect of fertilisers on germination and establishment of pastures and fodder crops. *Wool Tech. & sheep Breeding*, July 1969,69–75.
- Choi, C. H. and D. C. Erbach (1986). Cornstalk residue shearing by rolling coulters. *Trans. ASAE.*, **26**, (6): 1530–1535.
- Choudhary, M. A. and C. J. Baker (1981). Physical effects of direct drilling equipment on undisturbed soils. 1. Wheat seedling emergence under controlled climates. *NZ. J. Agric. Res.* **23**: 489–496.

- Choudhary, M. A., Gou Pei Yu, and C. J. Baker (1985). Seed placement effects on seedling establishment in direct-drilled fields. *Soil & Tillage Research*, **6**:79–93.
- Choudhary, M. A. (1988). Modelling of crop seedling emergence as a function of soil moisture and direct drilling openers. Proceedings of 11th International ISTRO Conference on Tillage and Traffic in Crop Production, Edinbrough 11–15th July 1988.
- Choudhary, M. A. and C. J. Baker (1993). Conservation tillage and seeding systems in the South Pacific. *Soil & Tillage Research*, **27**:283–302.
- Collis-George, N. (1987). Effects of soil physical factors on imbibition, germination, root elongation and shoot development. In: I. M. Wood, W. H. Hazard and F. R. From (Editors), *Crop Establishment Problems in Queensland: Recognition, Research and Resolutions*. Occas. Publ. No. 34, Australian Institute of Agricultural Science, Brisbane, Qld.: 23–41.
- Cook, S. J. and J. M. Scott (1987). Fertiliser placement strategies for establishment and growth of crops. In: I. M. Wood, W. H. Hazard and F. R. From (Editors), *Crop Establishment Problems in Queensland: Recognition, Research and Resolutions*. Occas. Publ. No. 34, Australian Institute of Agricultural Science, Brisbane, Qld.: 166–172.
- Cook, S. J., Clem R. L., MacLeod N. D. and P. A. Walsh (1993). Tropical Pasture Establishment. 7. Sowing methods for pasture establishment in northern Australia. *Tropical Grasslands*, **27**: 261–275.
- Elliott, L. F., McCalla T. M. and A. Waiss (1978). Phytotoxicity associated with residue management. In *Crop Residue Management*. W. R. Oschwald (Editor), ASA Special Publ. No 31 Am. Soc. of Agron., Madison, Wisc., 131–146.
- Fenner, M. (1992). Environmental influences on seed size and composition. *Hort. Rev.* **13**, 183–213.
- Ferraris, R. (1992). Seedbed factors affecting establishment of summer crops in a vertisol. *Soil & Tillage Research*, **23**, 1–25.
- Gebresenbet, G. and H. Jonsson (1992). Performance of seed drill coulters in relation to speed, depth and rake angles. *J. Agric. Engng. Res.* **52**, 121–145.
- Gramshaw, G. M., McKeon G. M. and Clem R. L. (1993). Tropical Pasture Establishment. 1. A systems perspective of establishment illustrated by oversowing in the sub-tropics. *Tropical Grasslands*, **27**: 261–275.
- Gray, D. (1981). Fluid drilling of vegetable seeds. *Hort. Rev.* **3**, 1–27.
- Gray, A. G. and D. MacIntyre (1983a). Studies of soil penetration by disc coulters of direct drills. SIAE Departmental Note No. SIN/361, Feb., 1983.
- Gray, A. G. and D. MacIntyre (1983b). Soil penetration by disc coulters of direct drills. *The Agricultural Engineer*, **38**(4):106–109.
- Grevis-James, I. W. and T. R. Kamel (1977). Conservation tillage: A glossary of selected terms. QDPI, Division of Land Utilisation, Tech. Bulletin No. 32/1977. Brisbane, Australia.
- Hadas, A. and D. Russo (1974). Water uptake by seeds as affected by water stress, capillary conductivity and seed-soil water contact. 2. Analysis of experimental data. *Agron. J.* **66**:647–652.
- Halderson, J. L. (1983). Planter selection accuracy for edible beans. *Trans ASAE*, **26**, (2):367–371.
- Harty, R. L., Heslehurst M. R. and J. McDonald (1987). Seed vigour. In: I. M. Wood, W. H. Hazard and F. R. From (Editors), *Crop Establishment Problems in Queensland: Recognition, Research and Resolutions*. Occas. Publ. No. 34, Australian Institute of Agricultural Science, Brisbane, Qld.: 79–86.
- Hayes, W. A. (1985). Conservation tillage systems and equipment requirements. In: *Systems Approach to Conservation Tillage*. F. M. D'Itri (Editor) Lewis Pub., 21–40.
- Heinonen, R. (1985). 'Soil management and crop water supply'. (4th Edition), Dept. Soil Sc. Swedish University of Agricultural Sciences, Uppsala, Sweden.
- Heslehurst, M. R. and J McDonald (1987). Seed quality components of successful field establishment. In: I. M. Wood, W. H. Hazard and F. R. From (Editors), *Crop Establishment Problems in Queensland: Recognition, Research and Resolutions*. Occas. Publ. No. 34, Australian Institute of Agricultural Science, Brisbane, Qld.: 141–153.
- Heyns, A. J. (1989). Techniques for the evaluation of precision planters. In *Land and Water Use*, Dodd & Grace (Editors). Balkema, Rotterdam.
- Hill, J. (1986). 'V' press wheels for light soil. Agfact E4.5, 1986. Dept. Ag. NSW. Aust.
- Holzhei, D. E. and T. H. Burkhardt (1985). Modelling the seed zone in the soil. ASAE paper No., 85–2020. Am. Soc. Agr. Eng., St Joseph, MI.
- Hopkinson, J. M. (1993). Tropical Pasture Establishment. 2. Seed characteristics and field establishment. *Tropical Grasslands*, **27**, 261–275.

- Janke, J. and D. C. Erbach (1985). Seed depth distribution in no till and strip till. ASAE Paper No., 85-1013. Am. Soc. Agr. Eng., St Joseph, MI.
- Jorgenson, M. E. (1988). Choosing the right seeding and fertilising equipment. PAMI Gleanings, No 558, March, 1988.
- Khan, A. A. (1992). Preplant physiological seed conditioning. *Hort. Rev.* **13**: 131-181.
- Kushwaha, R. L., Vaishanv, A. S. and G. C. Zoerb (1986). Soil-bin evaluation of disc coulters under no-till crop residue conditions. *Trans. ASAE.*, **29**(1):40-44.
- Lock, D. S. (1993). Tropical Pasture Establishment. 5. Improved handling of chaffy grass seeds: options, opportunities and value. *Tropical Grasslands*, **27**: 314-326.
- MacLeod, N. D., Walsh P. A., Cook S. J. and R. L. Clem (1993). Tropical Pasture Establishment. 16. Economic considerations for pasture establishment. *Tropical Grasslands*, **27**: 396-405.
- Maiti, R. K., and M. De J. Carrillo-Gutierrez (1989). Effect of planting depth on seedling emergence and vigour in sorghum. *Seed Sci. & Technol.*, **17**: 83-90.
- Martin, R. J. and W. L. Felton (1983). No-tillage crop production in northern N.S.W. Proceedings of the project team meeting, Agricultural Research Centre, Tamworth, May, 4th 1983).
- McGahan, E. J. and B. G. Robotham (1992). Effect of planting depth on yield in cereals. Proc. Conf. on Agric. Eng., Albury. I. E. Aust. Nat. Conf. Publ. No. 92/11:121-126.
- McLeod, J. G., Dyck, F B., Campbell, C. A. and C. L. Vera (1992) Evaluation of four zero-tillage drills equipped with different row openers for seeding winter wheat in the semi-arid prairies. *Soil & Tillage Research*, **25**: 1-16.
- Mead, J. A., Palmer, A. L. and K. Y. Chan (1992) Effect of seedbed condition on sowing point performance. *Soil & Tillage Research*, **22**: 13-25.
- Miller, C. P., Taylor J. A. and M. F. Quirk (1993) Tropical Pasture Establishment. 8. Management of establishing pastures. *Tropical Grasslands*, **27**: 344-348.
- Moller, N. (1975). Conventional coulters for small grain drilling. Institutionen for Arbetsmetodik Och Teknik. Report No. 28/1975.
- Morrison, J. E. and C. F. Abrams (1978). Conservation tillage opener for planters and transplanters. *Trans. ASAE*, **21**, (1):843-847.
- Morrison, J. E. (1978). No-tillage experimental planter performance and depth regulation evaluation. *Trans. ASAE*, **21**(4):602-604,609.
- Morrison, J. E. and T. J. Gerik (1985). Planter depth control: 2. Empirical testing and plant responses. *Trans. ASAE*, **28**, (6): 1744-1748).
- Morrison, J. E. (1988). Computerised selection of planters and drills: an example of the use of 'AI' in agriculture. Proceedings of 11th International ISTRO Conference on Tillage and Traffic in Crop Production, Edinbrough 11-15th July 1988, Vol 2: 775-780.
- Murray, D. H. A., Dodman R. L. and J. M. Marley (1987) Biotic factors in field crop establishment in Queensland with particular reference to insects, diseases and weeds. In: I. M. Wood, W. H. Hazard and F. R. From (Editors), Crop Establishment Problems in Queensland: Recognition, Research and Resolutions. Occas. Publ. No. 34, Australian Institute of Agricultural Science, Brisbane, Qld., 23-41.
- Norman, M., Schirmer, I. and N. H. Hancock (1992). The development of electronic moisture tracking for automatic depth control of planting depth. Proc. Conf. on Agric. Eng., Albury. I. E. Aust. Nat. Conf. Publ. No. 92/11:115-119.
- Norris, C. P. (1978). Comparative testing of seed metering and seed delivery equipment. Proc. Conf. on Agric. Eng., Toowoomba. I.E. Aust. Nat. Conf. Publ. 78/8:3-6.
- Norris, C. P. (1982). Performance of some different types of peanut/maize planters in NQ. Proc. Conf. on Agric. Eng., Armidale. I.E. Aust. Nat. Conf. Publ. No 82/8: 149-154.
- Norris, C. P., and I. A. Ryan (1993). Sunflower seeding equipment-The effect of field emergence on plant spacing accuracy. *Qld Agric. J.* **109**:331-335.
- Palmer, A. L., Smith P. A. and N. A. Albert (1988). The trouble with seeders. Proc. Conf. on Agric. Eng., Hawkesbury. I.E. Aust. Nat. Conf. Publ. No 88/12:61-63.
- Payton, D. M., Hyde, G. M. and J. B. Simpson (1985). Equipment and methods for no-tillage wheat planting. *Trans. ASAE*. **28**, (5):1419-1423.
- Perry, D. A. (1982). The influence of seed vigour on vegetable seedling establishment. *Scientific Horticulture*, **33**: 67-75.

- Radford, B. J. (1982). Establishment problems in summer and winter grain crops in Queensland and possible solutions. Proceedings QDPI Crop Establishment Workshop Toowoomba, May 1982.
- Radford, B. J. and R. G. H. Nielsen (1983a). Extension of crop sowing time during dry weather by means of stubble mulching and water injection. *Aust. J. Exp. Agri. Anim. Husb.*, **23**: 302–308.
- Radford, B. J. (1983b). Seed soaking. Agdex No 102/23., F195/Oct 83. QDPI., Brisbane, Aust.
- Radford, B. J. and R. G. H. Nielsen (1985). Comparison of a press wheel, seed soaking and water injection as aids to sorghum and sunflower establishment in Queensland. *Aust. J. Exp. Agric.*, **25**: 656–664.
- Radford, B. J. (1986). Effect of press wheel and depth of sowing on establishment of semi-dwarf and tall wheats. *Aust. J. Exp. Agric.*, **26**: 697–702.
- Radford, B. J. (1987). Crop establishment ailments – diagnosis and prevention. In: I. M. Wood, W. H. Hazard and F. R. From (Editors), *Crop Establishment Problems in Queensland: Recognition, Research and Resolutions*. Occas. Publ. No. 34, Australian Institute of Agricultural Science, Brisbane, Qld., 120–129.
- Rainbow, R. W., Slattery, M. G. and C. P. Norris (1992). Effects of seeder design specification on emergence and early growth of wheat. Proc. Conf. on Agric. Eng., Albury. I. E. Aust. Nat. Conf. Publ. No. 92/11:13–20.
- Riethmuller, G. P. (1990). Machinery for improved crop establishment in Western Australia. Proc. Conf. on Agric. Eng., Toowoomba. I.E. Aust. Nat. Conf. Publ. No 90/13:40–45.
- Roberts, E. H. and M. Black (1989). Seed quality. *Seed Sci. & Technol.*, **17**: 175–185.
- Rogers, R. B. and S. Dubetz (1979). Effect of soil-seed contact on seed imbibition. *Can. Agr. Eng.*, **22**, (1):89–92
- Saxton, K. E., (1990). Criteria for conservation tillage drills and the cross-slot opener. Proceedings of the Zero-Tillage Workshop, Bismark, N. Dakota Jan.17–19, 1990:69–74.
- Schaaf, D. E., Hann, S. A. and C. W. Lindwall (1981). Performance evaluation on furrow openers cutting coulters and press wheels for seed drills. In: *Crop Production with Conservation in the 80's*. ASAE Publ. No. 7/81: 76–84.
- Scott, J. M., (1989). Seed coatings and treatments and their effects on plant establishment. *Adv. Agron.*, **42**: 43–83.
- Slattery, M. G. and R. W. Rainbow (1992). Development of a seed placement test rig. Proc. Conf. on Agric. Eng., Albury. I. E. Aust. Nat. Conf. Publ. No. 92/11:365.
- Smith, E. M., Hammett, D. E. and H. J. Thompson (1979). Ground driven power tillage. ASAE Paper No. 79–1024. Am Soc. Agr. Eng. St Joseph, MI.
- Smith, E. M. (1979). Response of narrow row soybeans to populations and straw residue using a power-till seeder. ASAE Paper No. 79–1014. Am Soc. Agr. Eng. St Joseph, MI.
- So, H. B., (1987). Soil physical factors limiting crop establishment. In: I. M. Wood, W. H. Hazard and F. R. From (Editors), *Crop Establishment Problems in Queensland: Recognition, Research and Resolutions*. Occas. Publ. No. 34, Australian Institute of Agricultural Science, Brisbane, Qld.: 154–165.
- Stephens, L. E. and R. R. Johnson (1991). Soil conditions created by planting systems. ASAE Paper No. 91–1003. Am Soc. Agr. Eng. St Joseph, MI.
- Tessier, S., Papendick, R. I., Saxton, K. E. and G. M. Hyde (1989). Roughness meter to measure seed row geometry and soil disturbance. *Trans. ASAE*, **32**(6):1871–1873.
- Tessier, S., Saxton, K. E., Papendick, R. I. and G. M. Hyde.(1991a). Zero-tillage furrow opener effects on seed environment and wheat emergence. *Soil & Tillage Research*, **21**: 347–360.
- Tessier, S., Hyde, G. M., Papendick, R. I. and K. E. Saxton (1991b). No-till seeders effects on seed zone properties and wheat emergence. *Trans. ASAE*, **34**, (3):733–739.
- Thomas, T. H. (1981). Seed treatments and techniques to improve germination. *Sci. Hort.*, **32**: 47–59.
- Thomas, J. B. (1984). Even wider Australian tillage/seeding machinery-some challenges. Proc. Conf. on Agric. Eng., Bundaberg. I.E. Aust. Nat. Conf. Publ. No 84/6:108–112.
- Tice, E. M., Schafer, R. L. and C. E. Johnson (1988). Soil displacement by rolling coulters. Proceedings of 11th International ISTRO Conference on Tillage and Traffic in Crop Production, Edinbrough 11–15th July 1988.
- Tice, E. M. and J. G. Hendrick (1991). Disc coulter forces: Evaluation of mathematical models. *Trans. ASAE*, **34**, (6): 2291–2298.
- Tice, E. M. and J. G. Hendrick (1992). Disc coulter operating characteristics. *Trans. ASAE*, **35**, (1):3–10.
- Townsend, J. S. and J. M. Bethge (1984). Furrow opener for proper seed and fertiliser placement in no-till. ASAE Paper No. 84–151 Am Soc. Agr. Eng. St Joseph, MI.

- Unger, P. W. and B. A. Stewart (1976). Land preparation and seedling establishment practices in multiple cropping systems. In: M. Stelly (Editor), Multiple Cropping, ASA Special Publ., No 27, Am. Soc. Agron. Madison Wisc., 225–234.
- Unger, P. W., Eck H. V. and J. T. Musick (1981). Alleviating plant water stress. In: G. F. Arkin (Editor), Modifying the Root Environment to Reduce Crop Stress, ASAE. Mon. No 4., Am. Soc. Ag. Eng., St Joseph. Mich. 61–98.
- Vaishanv, A. S., Kushwaha, R. L. and G. C. Zoerb (1982). Evaluation of disc coulters as affected by straw and cone index under zero till practices. ASAE Paper No. 82–1517. Am Soc. Agr. Eng. St Joseph, MI.
- Van Doren, D. M. and R. R. Allmaras (1978). Effect of residue management practices of the soil physical environment, microclimate, and plant growth. In Crop Residue Management. W. R. Oschwald (Editor), ASA Special Publ. No 31 Am. Soc. of Agron., Madison, Wisc., 49–83.
- Ward, L. D., and C. P. Norris (1982). The development of zero-till planting systems for heavy clay soils. Proc. Conf. of Agric. Eng., Armidale. I.E. Aust. Nat. Conf. Publ. No. 82/8:189–196.
- Ward, L. D. (1987). Tillage and sowing operations for crop establishment. In: I. M. Wood, W. H. Hazard and F. R. From (Editors), Crop Establishment Problems in Queensland: Recognition, Research and Resolutions. Occas. Publ. No. 34, Australian Institute of Agricultural Science, Brisbane, Qld., 182–191.
- Ward, L. D., Norris, C. P. and E. C. Thomas (1991). Component interactions in zero till planters for heavy clay soils of southern Queensland. *Soil & tillage Res.*, **20**:19–32.
- Wiedemann, H. T., Wilks, L. H., and O. R. Kunze (1971). Design for optimum performance of a furrow opener to plant cottonseed in humid areas. *Trans ASAE*. **14**, (5):919–923.
- Wilkins, D. E., Allmaras, R. R., Muilenburg, G. A. and C. E. Johnson (1981). Effect of grain drill opener on wheat emergence. ASAE Paper No. 81–1021. Am Soc. Agr. Eng. St Joseph, MI.
- Wilkins, D. E., Allmaras, R. R., Muilenburg, G. A. and C. E. Johnson (1983). Grain drill opener effects on wheat emergence. *Trans. ASAE*, **26**(3):651–655,660.
- Wilkins, D. E., Klepper, B. and R. W. Rickman (1989). Measuring wheat seedling response to tillage and seeding systems. *Trans. ASAE.*, **32**(3):795:800.
- Wood, I. M., (1987). Crop establishment models and their role in agricultural research, extension and production. In: I. M. Wood, W. H. Hazard and F. R. From (Editors), Crop Establishment Problems in Queensland: Recognition, Research and Resolutions. Occas. Publ. No. 34, Australian Institute of Agricultural Science, Brisbane, Qld., 12–22.
- Wollin, A. S., McPhee, J. E., Robotham, B. G. and P. A. Walsh (1987). A review of engineering aspects of crop establishment. In: I. M. Wood, W. H. Hazard and F. R. From (Editors), Crop Establishment Problems in Queensland: Recognition, Research and Resolutions. Occas. Publ. No. 34, Australian Institute of Agricultural Science, Brisbane, Qld., 42–61.
- Zulin, Z., Upadhyaya, S. K., Shafii, S. and R. E. Garrett (1991). A hydropneumatic seeder for primed seeds. *Trans. ASAE*. **34**(1): 21–26. Am Soc. Agr. Eng. St Joseph, MI.

Index

- adjustable placement system 77
- Agrisystems™ cross-slot opener 77
- agronomic requirements
 - for crop establishment 10–23
 - for emergence 15–19
 - for establishment 19–23
 - for germination 10–15
- air assisted vertical plate type precision seed meters 131, 132–3
 - advantages over mechanical methods 132
 - cross-sectional view 132
 - expensiveness 133
 - seed box and typical plate 133
- air-lock system 151
- airstream loading methods (pneumatic delivery and/or division systems) 151–2
 - air lock or rotary valve system 151
 - pressurised box system 151
 - venturi system 151
- aligned single disc coulters type furrow openers 59
 - typical layout 61
- aligned twin inclined double disc coulters type furrow openers 66, 67
- aligned vertical and inclined double disc coulters type furrow openers 66, 67
- alignment of discs, double concave disc type row preparation devices 46
- animal-powered planters 26
- belt type precision seed meters 134–6
 - accuracy of metering 135
 - belt and base plate combination for a large cylindrical seed 135
 - belt and base plate combination for a small round seed 135
 - diagrammatic representation 134
 - side view 136
- bioblade type furrow openers 52, 53, 77–8
 - diagrammatic representation 77
 - front, rear and side views 78, 79
 - furrow cross-section 53
 - suitability 79
- blade type row preparation devices 42–3
- broadcast planters
 - classification 27, 29
 - description 154
- broadcast planting 20
- brush assisted vertical plate type precision seed meters 131, 133–4
 - cross-sectional view 133
 - plate housing and vertical plate 134
- bubble disc coulters 36, 37
- chain-and-bar type covering devices 85, 86
- chain type covering devices 85–6
 - chain-and-bar type 85, 86
 - looped chain type 85, 86
 - trailing chain 85
- check row planting 22
- classification parameters
 - number of rows planted 26
 - power source and methods of attachment 26–7
 - types of planter 27–8
- coil press type row specific seedbed firming devices 94, 100–1
 - as seedbed levelling device 100
 - suitability 100
- coleoptile elongation 16
- compound-angle single disc coulters type furrow openers 59
 - balancing side forces 62–4
 - disc mounting 60
 - front and side views 62
 - operational issues 60–1
 - position of depth/gauge wheel 60, 62
- concave disc type covering devices 85, 86–7
 - double concave disc 86, 87
 - operational issues 87
 - single concave disc 86
- concave disc type furrow openers 52, 56–8
 - applications 57
 - performance determinants 57
 - seed placement 57
- concave disc type row preparation devices 45–7
 - alignment for double disc type 46
 - combination with finger wheel type 47
 - double unit 45, 46
 - notched disc 45, 46, 47
 - plain disc 45, 46
 - single unit 45
- conservation cropping systems 64, 79
- conveyor type mechanically assisted seed delivery systems 147
- crop establishment
 - agronomic requirements 10–23
 - overview 8–9
 - planter functional requirements 24
- crop residue leachate, effect on germination 13
- crop residue mulches 12
- crop residue removal 40–1
- crop residues, planting through 79
- dedicated gauge wheel type of the parallelogram system 113, 114
- dedicated gauge wheel type of the trailing arm system of depth control 115, 116

- dedicated tine type furrow openers 70–4
 - inverted ‘T’ type 70, 73, 77
 - knife type 70, 72–3, 77
 - point type 70, 71–2, 77
 - seed placement devices 76
 - shoe type 70, 74, 76
- ‘delivery and division’ type pneumatic seed delivery systems 148–52
 - airstream loading methods 150–1
 - dividing heads 150
 - seed and fertiliser heads 150
 - typical layout 152
 - utilising primary and secondary heads 149–50
 - utilising primary heads only 148–9
- ‘delivery only’ type pneumatic seed delivery systems 148
- depth control *see* furrow opener depth control
- dibble planters
 - classification 28, 30
 - description 157
- dibble planting 22
- dicotyledonous species, emergence 16, 95
- disc coulters soil and residue cutting devices 34–9
 - functional requirements 34–5
 - operational requirements 35
 - types of 36–8
- disc coulters type covering devices 85, 87–8
 - double disc coulters 87, 88
 - single disc coulters 87
- disc coulters type furrow openers 52, 58–69
 - double disc type 58, 65–8
 - single disc type 58, 59–65
 - triple disc type 58, 69
- diurnal variation 12
- double concave disc type covering devices 86
 - rear view 86, 87
- double concave disc type row preparation devices 45, 46, 47
 - alignment of discs 46
- double disc coulters type covering devices 87
 - side and rear views 87–8
- double disc coulters type furrow openers 58, 65–8
 - aligned and staggered design options 66–8
 - fitted with seed firming slide 83
 - operational issues 66–7
 - seed placement devices 68
 - twin inclined type 65, 66, 67, 68
 - vertical and inclined type 65, 66, 67
- double finger wheel row preparation devices 43, 44
- double finger wheel type covering devices 92
- double run mass flow seed meters 120, 125
- drill planters
 - classification 27, 29
 - description 155
- drill planting 21
- dropper tubes 56, 57, 68, 144, 145
 - fitted with seed firming slides 83
 - termination design 68, 145
- dual-purpose tine type furrow openers 70, 75–7
 - duckfoot type 53, 75, 76
 - for weed control 75
 - reversible point type 75, 76
 - seed placement devices 76
 - sweep type 75, 76
- duckfoot type dual-purpose tine type furrow openers 75, 76
 - for weed control 75
 - furrow cross-section 53
- emergence
 - agronomic requirements 15–19
 - and planting depth 17–18, 106
 - implications for planter performance 17–19
 - shoot development and emergence 16–17
 - see also* root development/elongation
- emergence failure 16–17
- environmental factors
 - affecting germination 11–13
 - affecting planter soil-engaging components 13–15
- epicotyl elongation 16
- epigeal germination 95
- establishment
 - agronomic requirements 19–23
 - implications for planter performance 23
 - plant competition 19
 - plant populations and spacing requirements 19–22
- external force feed mass flow seed meters 122–5
 - fluted roller type 120, 123–4
 - general principles of operation 122
 - peg/studded roller type 120, 124–5
- fertiliser toxicity 13
- finger harrow type non row specific seedbed firming/levelling devices 105
- finger harrow type row preparation devices 47–8
- finger pick-up type precision seed meters 139–40
 - adjustment 140
 - diagrammatic representation 139
 - operation 139–40
 - singulation process 139–40
- finger type covering devices 85, 91
 - multiple finger type 91
 - single finger type 91
- finger wheel row preparation devices 45–7
 - combination with concave disc type 47
 - double-wheel 43, 44
 - optional wheel positions 44
 - single-wheel 43, 44
 - spring steel 44–5
- finger wheel type covering devices 85, 92
 - double finger wheel 92
 - single finger wheel 92
- finger wheel type row specific seedbed firming devices 94, 99
 - combined with inclined press wheel 99
 - shape and adjustment 99
- fixed placement system 77
- fluted disc coulters 36, 38

- fluted roller mass flow seed meters 120, 123–4
 - adjustments 123–4
 - front view 124
 - general form 123
- forward curved shoe type dedicated tine type furrow openers 74
- frame section gauging systems (furrow opener depth control) 108–10
 - drill planters utilising frame section gauging 110
 - trailed, rigid hitch, 4-bar, 3 section flexible-framed cultivator/planter operating on an irregular surface 109
 - trailed, rigid hitch, 4-bar, rigid frame cultivator/planter operating on a flat seedbed surface 108–9
 - trailed, rigid hitch, 4-bar, rigid frame cultivator/planter operating on an irregular surface 109
- front gauge wheel type of the parallelogram system 114
- full runner type furrow openers 54, 55
- furrow cross-sections 53
- furrow opener depth control components 106–17
 - functional requirements 107
 - operational requirements 107
- furrow opener depth control mechanisms
 - frame section gauging systems 108–10
 - individual row gauging systems 111–17
 - types of 108–17
- furrow opener design
 - and optimum germination 14
 - and seedling emergence 18–19
- furrow opener spacing 23
- furrow opening devices 51–80
 - bioblade type 77–8
 - concave disc type 56–8
 - disc coulter type 58–69
 - functional requirements 51
 - furrow cross-sections 53
 - importance of pre-cutting soil and root material 35
 - limitations to narrowness 52
 - operational requirements 51–2
 - powered opener type 78–9
 - punch type 79–80
 - runner type 54–6
 - tine type 70–7
 - types of 52–80
- furrow shape 23
- germination
 - agronomic requirements 10–15
 - implications for planter performance 13–15
 - environmental factors affecting 11–13
 - seed factors affecting 10–11
- gravity drop seed delivery systems 144–5
 - operation 144
 - using dropper tubes 144, 145
 - using split cavity of a runner opener 144
 - using tube terminating with a rearward deflection 145
- hard-setting 17
- harrow type non row specific seedbed firming/levelling devices 103, 105
 - finger type 105
 - rotary type 105
- hill drop planting 21
- horizontal disc type row preparation devices 50
- horizontal plate type precision seed meters 127, 128
 - adjustments 128
 - side, top and rear views 128
- horticultural planter, soil-engaging components on 33
- human-powered planters 26
- hypocotyl elongation 16
- hypogeal germination 95
- inclined plate type precision seed meters 127, 129–30
 - limitations 130
 - side, top and rear views 129, 130
 - with and without seed baffle 129
- inclined press wheel type row specific seedbed firming devices 95
 - combined with finger wheel 99
 - indicative pressure zones 98
 - single inclined type 98
 - suitability 99
 - twin inclined type 98
- individual row depth control
 - parallelogram systems 111–14
 - trailing arm systems 115–17
- individual row gauging systems for furrow opener depth control 111–17
 - parallelogram systems 111–14
 - trailing arm systems 115–17
- inter-row spacing requirements 23
- internal force feed type mass flow seed meters 125–6
 - adjustment 125–6
 - double run type 120, 125
 - front and side view 126
 - path of seed movement 125
- intra-row spacing requirements 23
- inverted ‘T’ type dedicated tine type furrow openers 70
 - front and side view 73
 - general form 73
- knife type covering devices 85, 88–9
 - opposed knives 88, 99
 - single knife 88
- knife type dedicated tine type furrow openers 70, 72–3
 - general form 72
 - seed placement devices 77
 - suitability 72
- knife type tine row preparation device 48, 49
- light requirements for germination 11
- looped chain type covering devices 85, 86
- loose seedbeds, opener design 14

- mass flow seed metering devices 119, 120–6
 - double run type 120, 125
 - external force feed types 122–5
 - fluted roller type 120, 123–4
 - internal force feed types 125–6
 - peg/studded roller type 120, 124–5
 - stationary opening type 120–2
- mechanical vertical plate type precision seed meters 131–2
 - adjustments 131
 - side and top views 131, 132
- mechanically assisted seed delivery systems 144, 145–7
 - conveyor type 147
 - oscillating spout type 146–7
 - spinning disc type 146
- mesocotyl elongation 16
- moisture availability
 - and degree of soil disturbance 14
 - and planter operation 14
- moisture seeking 40
- moisture supply, rate of, effect on germination 11–12
- monocotyledonous species, emergence 16, 95
- mounted planters 27
- multiple finger type covering devices 91

- near vertical shoe type dedicated tine type furrow openers 74
- non row specific seedbed firming/levelling devices 102–5
 - functional requirements 102
 - harrow type 103, 105
 - operational requirements 102
 - packer type 103, 104
 - roller type 103–4
 - types of 103–5
 - see also* row specific seedbed firming devices
- notched disc coulters 36, 37
 - on concave disc type row preparation devices 45, 46, 47
- number of rows planted 26

- opening devices *see* furrow opening devices
- opposed knife type covering devices 88, 99
- opposed paddle type covering devices 89
- opposed tine type covering devices 90
- oscillating spout type mechanically assisted seed delivery systems 146–7
- over-centre press wheel type row specific seedbed firming devices 95, 96
 - flat profile 96
 - single rib profile 96
 - wedge profile 96
- over-compaction
 - and seedling emergence 19
 - with double disc coulter type furrow openers 66
 - with runner type openers 55
- oxygen requirement for germination 11

- packer type non row specific seedbed firming/levelling devices 103, 104
 - coil type 104
 - toothed type 104
- paddle type covering devices 85, 89
 - opposed paddles 89
 - single paddle 89
- parallelogram systems of individual row depth control 111–14
 - adjustments 111
 - dedicated gauge wheel type 112, 113
 - gauge wheel positions 112
 - rear gauge wheel type 113
 - twin gauge wheel type 112, 114
- peg/studded roller mass flow seed meters 120, 124–5
 - adjustments 125
- plain disc coulters 36, 37
 - on concave disc type row preparation devices 45, 46
- plant competition 19
- plant establishment
 - probability curves 8
 - variables affecting 9
- plant populations and spacing requirements 19–22
- planter classification 25
 - examples 29–30
 - key 158
 - parameters 26–8
 - see also* planter description
- planter components 31
 - furrow opener depth control components 106–17
 - seed delivery components 142–52
 - seed metering components 118–41
 - soil-engaging components 32–105
- planter description 25
 - examples 153–7
 - key 159–64
- planter functional requirements for crop establishment 24
- planter performance
 - implications for establishment 23
 - implications for germination 13–15
 - implications for root elongation and shoot emergence 17–18
- planters
 - number of rows planted 26
 - power source 26–7
 - types of 27–8
- planting depth
 - achieving optimum 106
 - and emergence 17–18, 106
 - control components 106–17
- planting patterns 20–2
- planting through crop residues, opener design 14
- planting to moisture 40
- plastic mulch, planting through 79–80
- plate type precision seed meters 127–34
 - horizontal plate type 127, 128
 - inclined plate type 127, 129–30
 - vertical plate type 127, 131–4

- pneumatic seed distribution and/or delivery systems
144, 147–52
‘delivery and division’ systems 148–52
‘delivery only’ systems 148
- point type dedicated tine type furrow openers 70
general form 71
reversible point type 72
seed placement devices 77
winged point version 71, 72
wingless point version 71
- powered planters 26–7
animal-power 26
human-power 26
tractor-power 27
- powered type furrow openers 52, 78–9
diagrammatic representation 78
seed placement 78
suitability 79
- precision drill planting 21
- precision planters
classification 28, 30
description 156
- precision seed metering devices 119, 127–40
belt type 134–6
finger pick-up type 139–40
plate type 127–34
pressurised drum type 138–9
vacuum disc type 136–7
- pre-cutting soil and root material 35
- pre-sowing seed treatments
effect on germination 11
impact on seed metering performance 13
- press wheel type row specific seedbed firming devices
94, 95–9
inclined type 95, 98–9
over-centre type 95, 96
zero pressure type 95, 97
- pressurised box system 151
- pressurised drum type precision seed meters 138–9
operation 138
rear side view 139
sectional view 138
- punch planters 28
- punch planting 22
- punch type furrow openers 52, 79–80
- purity, effect on germination 10
- rear gauge wheel type
parallelogram system 113
trailing arm system of depth control 115, 116
- rearward curved shoe type dedicated tine type furrow
openers 74
seed placement device 76
- reduced tillage planting 87, 96
- removing dry soil to permit planting (row preparation
devices) 40
- removing residues from the soil surface (row
preparation devices) 40–1
- residue-cutting devices *see* soil and residue cutting
devices
- residue-cutting function, usefulness of 34, 51
- residues *see* crop residues
- reversible point dedicated tine type furrow openers 72
- reversible point dual-purpose tine type furrow openers
75, 76
- ripple disc coulters 36, 38
- roller type non row specific seedbed firming/levelling
devices 103–4
metal roller 103, 104
tyre type roller 103, 104
wooden roller 103, 104
- roller type row preparation devices 49
- root development/elongation
factors affecting 15–16
implications for planter performance 17–19
- rotary disc type seed placement devices 65
- rotary harrow type non row specific seedbed
firming/levelling devices 105
rigid and flexible forms 105
- rotary valve system 151
- ‘row crop’ planting 22
- row preparation devices 40
blade type 42
combination of concave disc and finger wheel type
47
concave disc type 45–7
finger harrow type 47–8
finger wheel type 43–5
functional requirements 40–1
horizontal disc type 50
operational requirements 41
roller type 49
tine type 49–50
types of 42–50
- row spacing 20–2
and planter performance 23
- row specific seedbed firming devices 93–101
coil press type 94, 100–1
finger wheel type 94, 99
functional requirements 93–4
operational requirements 94
press wheel type 94, 95–9
types of 94–101
see also non row specific seedbed
firming/levelling devices
- runner type furrow openers 52, 54–6
attachments 55
full runner type 54, 55
seed placement 56
shape of runner effects 55
sizes and types 56
stub runner type 54, 55
suitability 54–5
use with seed firming wheels 82
- seed covering devices 84–92
chain type 85–6
concave disc type 86–7
disc coulter type 87–8
finger type 92
finger wheel type 92
functional requirements 84

- knife type 88–9
- operational requirements 84–5
- paddle type 89
- tine type 90
- types of 85–92
- seed delivery systems 142–52
 - functional requirements 142
 - gravity drop 144–5
 - mechanically assisted 144, 145–7
 - operational requirements 143
 - pneumatic 144, 147–52
 - types of 144–52
- seed delivery tube 23
- seed factors
 - affecting germination 10–13
 - affecting planter performance 13–15
- seed firming devices 81–3
 - functional requirements 81
 - operational requirements 81
 - types of 82–3
- seed firming slides 83
- seed firming wheels 82
- seed metering devices 118–41
 - and intra-row spacing 23
 - functional requirements 118
 - impact of pre-sowing seed treatments on 13
 - impact of seed quality on 13
 - mass flow meters 120–6
 - operational requirements 118
 - precision meters 127–40
 - selection 141
 - types of 119–40
- seed placement components 14, 18, 23
- seed placement devices
 - adjustable placement system 77
 - dedicated tine type furrow openers 76
 - double disc coulter type furrow openers 68
 - dropper tubes 56, 57, 68, 144, 145
 - dual-purpose tine type furrow openers 76
 - fixed placement system 77
 - knife type dedicated tine type furrow openers 77
 - point type dedicated tine type furrow openers 77
 - rotary disc type 65
 - shoe type dedicated tine type furrow openers 76–7
 - single disc coulter type furrow openers 64–5
 - single-angle single disc coulter type furrow openers 64, 65
 - wedge-shaped 57–8, 65
 - with rearward curved shoe type opener 76
- seed quality
 - effect on germination 10–11
 - impact on seed metering device performance 13
- seed reserves 16
- seed size
 - effect on germination 11
 - impact on planter performance 13
- seed vigour 10–11
- seedbed disturbance
 - and furrow opening process 14
 - overcoming 14–15
- seedbed firming devices
 - selection 14
 - see also* non row specific firming/levelling devices; row specific seedbed firming devices
- seedbed levelling and firming function (row preparation devices) 40
- seedbed levelling devices 91, 101
 - see also* non row specific seedbed firming/levelling devices
- seeding depth, and tillage depth 14, 15
- semi-mounted planters 27
- shoe type dedicated tine type furrow openers 70, 74
 - forward curved form 74
 - near vertical form 74
 - rearward curved form 74
 - seed placement devices 76–7
- shoot development/emergence
 - factors affecting 16–17
 - implications for planter performance 17–19
- single-angle single disc coulter type furrow openers 59
 - balancing side forces 62–4
 - front and side views 62
 - position of depth/gauge wheel 60, 62
 - seed placement devices 64, 65
 - vertical disc mounting 60
- single concave disc type covering devices 86
- single concave disc type furrow openers 57
- single concave disc type row preparation devices 45
- single disc coulter type covering devices 87
- single disc coulter type furrow openers 58, 59–65
 - aligned type 59, 61
 - balancing side forces 62–4
 - compound-angle type 59, 60–1, 62–3
 - openers arranged in opposed pairs 63
 - openers mounted in opposed pairs on a common arm 63
 - operational issues 60
 - opposed openers sharing a common press wheel 64
 - performance limitations 59
 - seed placement devices 64–5
 - single-angle type 59, 60, 62–3, 64, 65
 - use in conservation cropping systems 64
- single finger type covering devices 91
- single finger wheel row preparation devices 43, 44
- single finger wheel type covering devices 92
- single inclined press wheel type row specific seedbed firming devices 98
- single knife type covering devices 88, 99
- single paddle type covering devices 89
- single vertical disc opener, furrow cross-section 53
- smearing
 - and seed emergence 19
 - with runner-type openers 55
- soil and residue cutting devices 34–9
 - functional requirements 34–5, 41
 - operational requirements 35
 - types of 36–8
- soil conditions
 - effect on roots 15–16
 - effect on seedling emergence 18–19

- soil cutting and/or disturbance function, usefulness of 34–5
- soil density, and germination 11–12
- soil disturbance, impact on moisture availability 14
- soil-engaging components 32–3
 - effect on germination 13–15
 - furrow opening devices 51–80
 - non row specific seedbed firming/levelling devices 102–5
 - row preparation devices 40–50
 - row specific seedbed firming devices 93–101
 - seed covering devices 84–92
 - seed firming devices 81–3
 - soil and residue cutting devices 34–9
- soil moisture, effect on germination 11–12
- soil strength
 - effect on emergence 16
 - effect on germination 12
- soil structure, effect on roots 15
- soil temperature, effect on germination 12
- solid planters 27
- ‘solid’ planting 22
- sorghum emergence 16
- soybean emergence 16
- spacing requirements 19–22
 - planting patterns 20–2
- specialised planters 28
- spinning disc type mechanically assisted seed delivery systems 146
- staggered twin inclined double disc coulter type furrow openers 66, 67, 68
- staggered vertical and inclined double disc coulter type furrow openers 66, 67
- stationary opening type seed meters 120–2
 - used for pasture renovation 121–2
 - using a rotating plate to adjust outlet size 121
 - using a sliding plate to adjust outlet size 120–1
- stub runner type furrow openers 54, 55
- studded roller mass flow seed meters 120, 124–5
- surface crusting 17
- sweep type dual-purpose tine type furrow openers 75, 76
 - for weed control 75
- sweep type tine row preparation devices 48, 49

- three bar finger harrow type row preparation devices 47, 48
- tillage depth, and seeding depth 14, 15
- tine type covering devices 85, 90
 - operational issues 90
 - opposed tines 90
- tine type furrow openers 52, 53, 70–6
 - dedicated type 70–4
 - dual-purpose type 70, 75–7
 - residue effect on performance 34
 - seed placement devices 76, 77
- tine type row preparation devices 48–9
 - knife type 48, 49
 - sweep type 48, 49
- toxic substances, effect on germination 12–13
- tractor-powered planters 26

- trailed planters 27
- trailing arm systems of individual row depth control 115–17
 - dedicated gauge wheel type 115, 116
 - rear gauge wheel type 115, 116
 - twin gauge wheel type 115, 117
- trailing chain type covering devices 85
- triple disc coulter type furrow openers 58, 69
 - layout 69
 - rear view 69
- turbo disc coulters 36, 38
- twin gauge wheel type
 - parallelogram system 114
 - trailing arm system of depth control 115, 117
- twin inclined double disc coulter type furrow openers 65
 - aligned option 66, 67
 - staggered option 66, 67, 68
- twin inclined double disc opener, furrow cross-section 53
- twin inclined press wheel type row specific seedbed firming devices 98
 - aligned 98
 - staggered 98

- vacuum disc type precision seed meters 136–7
 - component disc 137
 - diagrammatic representation 137
 - operation 136–7
 - side view 137
- venturi system 151
- vertical and inclined double disc coulter type furrow openers 65
 - aligned and staggered design options 66, 67
- vertical plate type precision seed meters 127, 131–4
 - air assisted type 131, 132–3
 - brush assisted type 131, 133–4
 - mechanical type 131
- viability, effect on germination 10

- water availability, duration of, effect on germination 12
- water requirements for root growth 15–16
- wavee disc coulters 36, 38
- wedge shaped seed placement devices 57–8, 65
- weed control 75, 90
- wheat emergence failure 16
- winged version point type dedicated tine type furrow openers 71, 72
- wingless version point type dedicated tine type furrow openers 71

- zero pressure press wheel type row specific seedbed firming devices 95, 97
 - moulded type 97
 - soft centre (plain or ribbed) type 97
 - split packer type 97
 - usefulness 97
- zero tillage planting 87, 96