



AgEcon SEARCH

RESEARCH IN AGRICULTURAL & APPLIED ECONOMICS

The World's Largest Open Access Agricultural & Applied Economics Digital Library

This document is discoverable and free to researchers across the globe due to the work of AgEcon Search.

Help ensure our sustainability.

Give to AgEcon Search

AgEcon Search

<http://ageconsearch.umn.edu>

aesearch@umn.edu

*Papers downloaded from **AgEcon Search** may be used for non-commercial purposes and personal study only. No other use, including posting to another Internet site, is permitted without permission from the copyright owner (not AgEcon Search), or as allowed under the provisions of Fair Use, U.S. Copyright Act, Title 17 U.S.C.*

No endorsement of AgEcon Search or its fundraising activities by the author(s) of the following work or their employer(s) is intended or implied.

MAYER • BROWN

Consolidation and Competition in Agribusiness

USDA Agricultural Outlook Forum

William H. Stallings
wstallings@mayerbrown.com

February 23, 2018

Mayer Brown is a global legal services provider comprising legal practices that are separate entities (the "Mayer Brown Practices"). The Mayer Brown Practices are: Mayer Brown LLP and Mayer Brown Europe-Brussels LLP, both limited liability partnerships established in Illinois USA; Mayer Brown International LLP, a limited liability partnership incorporated in England and Wales (authorized and regulated by the Solicitors Regulation Authority and registered in England and Wales number OC 303359); Mayer Brown, a SELAS established in France; Mayer Brown Mexico, S.C., a sociedad civil formed under the laws of the State of Durango, Mexico; Mayer Brown JSM, a Hong Kong partnership and its associated legal practices in Asia; and Tauil & Chequer Advogados, a Brazilian law partnership with which Mayer Brown is associated. Mayer Brown Consulting (Singapore) Pte. Ltd and its subsidiary, which are affiliated with Mayer Brown, provide customs and trade advisory and consultancy services, not legal services. "Mayer Brown" and the Mayer Brown logo are the trademarks of the Mayer Brown Practices in their respective jurisdictions.

Consolidation and Competition in Agribusiness

My remarks today will focus on four aspects of antitrust merger review specific to agriculture:

- I. Protecting Farmers Is a Goal of the Merger Laws
- II. Accounting for Innovation in Agricultural Markets
- III. Global Nature of Agricultural Merger Enforcement
- IV. The Challenges of Remediating a Problematic Merger

I. Protecting Farmers

- Merger law is designed to prevent firms from acquiring “market power” through a merger or acquisition
 - Market power is the ability to raise price, reduce output, diminish innovation or otherwise harm *consumers*
- Antitrust law clearly protects consumers, but what about farmers or other “upstream” producers?
 - Certain mergers may allow the combined firm to *reduce* the prices paid for goods or services
- For example, assume there are only two grain elevators in a geographic area. If they merge, they could have the ability to lower the prices they pay to farmers
 - Is the lower price an *efficiency* (*i.e.*, lower costs) or *anticompetitive harm* (an exercise of market power)?

I. Protecting Farmers

- This area of antitrust law was unsettled given the view that antitrust law is designed to protect consumers
- But, over the last 15 years, it is clear that the federal antitrust agencies (DOJ/FTC) take into account “upstream” harm
- Rationale: Even though “monopsony” power results in lower prices, there is still harm to the competitive process
 - Causes transfer of wealth and inefficiently reduces supply
 - Harm *even if* no downstream consumer effect
- Antitrust Agencies put this principle in their 2010 *Merger Guidelines*, specifically enshrining the “farmer example” (n.24)
 - Harm if merging local grain elevators reduce prices to local farmers even if no change in the ultimate price of grain to consumers

I. Protecting Farmers

- The DOJ has applied this principle to block deals or insist on remedies in numerous agriculture mergers:
 - *U.S. v. Cargill* (2000) (acquisition of competing grain trader would harm competition in grain purchasing services; divestiture)
 - *U.S. v. JBS* (2008) (acquisition of competing beef packer would harm competition for purchase of fed cattle; parties abandoned deal)
 - *U.S. v. George's Foods* (2011) (acquisition of competing chicken processor would harm competition in market for purchase of broiler growing services; remedy to protect growers)
 - *U.S. v. Tyson Foods* (2014) (acquisition of competing pork purchaser would reduce competition for purchase of sows from farmers; divestiture of sow procurement business)

II. Protecting Innovation

- General assumption that competition spurs firms to innovate
 - But, it is hard to quantify or predict “innovation”
- The antitrust concern is that a merger may decrease the *rate* of innovation or reduce the *incentive* to innovate
- The 2010 *Merger Guidelines* addresses innovation effects
 - Will merger cause firms to curtail innovative efforts?
 - If so, could other firms step up?
 - Or, could the merger even promote innovation by combining different capabilities?
- How do these issues play out in practice? The Antitrust Division’s recent challenge to Deere’s acquisition of Precision Planting from Monsanto provides a case example.

U.S. v. Deere/Monsanto: the Precision Planting matter

- “Planters” are critical pieces of farm equipment
 - Used only once a year, but entire crop depends on its success
- Precision Planting (a subsidiary of Monsanto): Reputation for developing innovative technology for planters
 - Precision Planting sold after-market parts for use on Deere planters
 - Equipment companies such as CNH Industrial and AGCO worked with Precision Planting



Market moving toward “High Speed Precision Systems”

- Deere and Precision Planting had only viable technologies for high-speed; each system was patent-protected

Precision Planting

SpeedTube **Belt** Delivery System

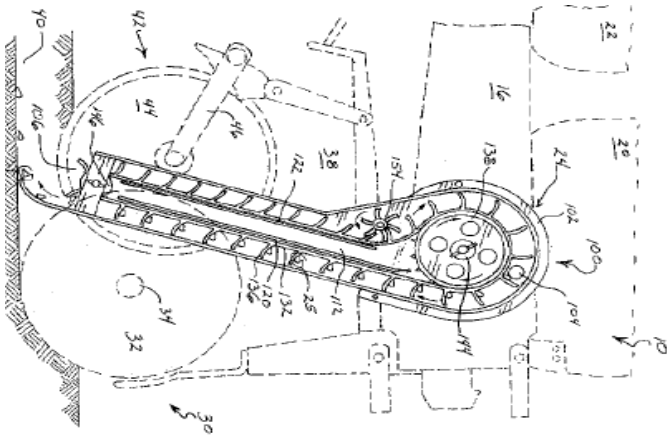

VS.

Deere

Brush Delivery System

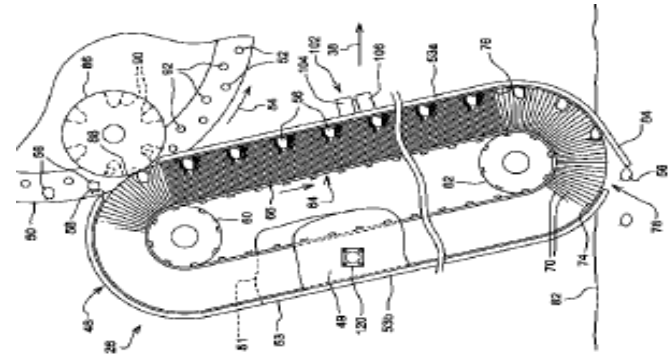

DOJ Sues to Block Deere's Acquisition of Precision (Aug. 2016)

Case: 1:16-cv-08515 Document #: 1 Filed: 08/31/16 Page 1 of 19 PageID #:1

UNITED STATES DISTRICT COURT FOR
THE NORTHERN DISTRICT OF ILLINOIS
EASTERN DIVISION

UNITED STATES OF AMERICA,
U.S. Department of Justice
Antitrust Division
450 Fifth Street NW, Suite 4000
Washington, DC 20530,

Plaintiff,

v.

DEERE & COMPANY
One Deere Place
Moline, IL 61265,

PRECISION PLANTING LLC
22307 Townline Road
Tremont, IL 61568,

and

MONSANTO COMPANY
800 North Lindbergh Blvd.
St. Louis, MO 63167,

Defendants.



DOJ's complaint focused on how the merger would impact innovation:

- Described how Deere and Precision each tried to leapfrog the other's technology. "Within the past three years, Deere and Precision Planting have each introduced high-speed precision planting systems that represent a 'True Gamechanger for Agriculture.'" (¶ 1)
- "Competition between Deere and Precision Planting benefits farmers through lower prices and more innovative high-speed precision planting systems in the marketplace." (¶ 6)
- "The transaction would . . . likely result in the elimination of innovation rivalry by the two leading innovators in the high-speed precision planting systems market." (¶ 48)

COMPLAINT

The United States of America, acting under the direction of the Attorney General of the United States, brings this civil action to enjoin the proposed acquisition by Defendant Deere & Company ("Deere") of Defendant Precision Planting LLC ("Precision Planting"), a subsidiary of Defendant Monsanto Company ("Monsanto"). The United States alleges as follows:

Parties Abandon Transaction on Eve of Trial

- On May 17, 2017, Monsanto abandoned the deal
 - Note that the administration changed between the filing of the Complaint and the abandonment of the deal
- The Antitrust Division (under the new Trump administration) issued a public statement confirming that it would continue to focus on agriculture and farmers:
 - “The companies’ decision to abandon this transaction is a **victory for American farmers** and consumers **Agriculture is one of the most important sectors of our economy** and **the Antitrust Division will remain vigilant to ensure that competition in agriculture markets is not thwarted through illegal transactions.**”
- After the deal was abandoned, AGCO purchased Precision

III. Global Nature of Merger Enforcement

- A major trend in merger enforcement is the growing number of international agencies with merger review
 - Global companies must navigate the thicket of multiple agency review
- And, many agencies have “cooperation” agreements with U.S.



- Given global agriculture markets, most deals require international review, adding time for the review and potentially resulting in more complex remedies

IV. Crafting Remedies

- How do you fix a problematic deal?
 - Blocking the deal provides complete relief; but is there a way to preserve any merger benefits while remedying the harm?
- Curing the competitive harm is the goal
 - The dollar amount of a remedy is irrelevant
 - The more complex a deal, the harder it is to fix
- Agencies' policy views on divestiture remedies:
 - The risk of a failed remedy should be borne by the parties, not consumers
 - Remedy must be complete and effective
 - Need a strong buyer ready, willing and able to compete

IV. Crafting Remedies

- Agencies favor (1) structural remedies over behavioral ones and (2) lines of business over asset carve-outs
- Problems with behavioral remedies:
 - Turns DOJ into a regulator (a “hall monitor for business”)
 - May only delay exercise of market power
 - Too much time spent investigating compliance
- Problems with asset carve-out divestitures
 - Government lawyers deciding bucket of assets
 - High execution risk, especially when dealing with a global deal
 - May require ongoing entanglements with merging parties