



**AgEcon** SEARCH  
RESEARCH IN AGRICULTURAL & APPLIED ECONOMICS

*The World's Largest Open Access Agricultural & Applied Economics Digital Library*

**This document is discoverable and free to researchers across the globe due to the work of AgEcon Search.**

**Help ensure our sustainability.**

Give to AgEcon Search

AgEcon Search

<http://ageconsearch.umn.edu>

[aesearch@umn.edu](mailto:aesearch@umn.edu)

*Papers downloaded from **AgEcon Search** may be used for non-commercial purposes and personal study only. No other use, including posting to another Internet site, is permitted without permission from the copyright owner (not AgEcon Search), or as allowed under the provisions of Fair Use, U.S. Copyright Act, Title 17 U.S.C.*

*No endorsement of AgEcon Search or its fundraising activities by the author(s) of the following work or their employer(s) is intended or implied.*

# TECHNOLOGY AND INNOVATION

## SERBIA: A NEW PROCESS FOR WASTE RUBBER AND PLASTIC RECYCLING

RADE VORKAPIC,  
Independent Consultant, Belgrade, Serbia

OZREN OCIC, PH. D.,  
LARISA KURCUBIC  
Oil Refinery, Pancevo, Serbia

BILJANA JOVANOVIC  
Faculty of Organizational Sciences  
University of Belgrade, Serbia

**JEL Classifications:** Q53, Q55

**Key words:** Process innovation, waste rubber and plastic recycling, eco-innovation, financially profitable.

**Abstract:** This paper intends to describe a new technological process for waste rubber and plastic recycling up to the commercial components in safe environmental friendly way. Researches and all relevant technical-technological data related to this process are checked at constructed pilot plant. The future construction of these units for waste rubber and plastic recycling will allow interested parties to achieve the environmental effectiveness and economic efficiency.

ISSN: 1804-0527 (online) 1804-0519 (print)

PP. 105-108

### Introduction

Waste rubber and plastic recycling processes being used nowadays are not adequate from the standpoint of protection and preservation of the environment, as well as profitability of the processes itself. Detailed researches are performed in order to improve the existing actions of recycling the waste rubber and plastic in the safest environmental way. Results of these researches in the form of new developed technological process for complete decomposition of waste rubber and plastic to high commercial components (fuel gas, naphtha, diesel fraction, carbon black and steel metal waste) are shown. Besides environmental effectiveness characteristics, construction of the unit for waste rubber and plastic recycling in Serbia (and other interested countries) would contribute to achieving the economic efficiency.

### Waste rubber and plastic recycling process

**The As-is situation.** Technological processes of rubber and plastic recycling, which are used today, basically include technological operations of rubber and plastic pulverization. Material, i.e. rubber and plastic, is cut to small pieces (usually 5 cm long). Obtained pieces are put through the series of so-called granulators, where their size continues to reduce in accordance with their intended usage. Usage of end pieces of rubber and plastic is various. For example, rubber pieces can be used as filler in civil engineering and building construction. Fine-pulverized and screened rubber can be used as base on children playgrounds. Rubbed pieces can be used for improved quality asphalt, while rubber mixed with urethane can be used for setting-up the athletic tracks. Also, it is possible to integrate the rubber parts with soil, i.e. grassy

surfaces. In that way the water flow through the soil is improved and the need for water, fertilizers and pesticides is reduced within 25 to 50 years. Rough pieces of rubber can be used for obtaining the energy in furnaces for cement production, paper production, thermoelectric power plant, and industrial boilers. It should be emphasized that rubber is, nowadays, frequently burnt while still in large pieces, by which the costs of pulverization are avoided, but on the other hand, the costs of storage and transportation are increased followed by inevitable negative effects on the environment.

**Process innovation.** New technological process for rubber and plastic recycling is developed by Rade Vorkapic, one of the authors of this paper. It enables the complete rubber and plastic decomposition to the commercial components (Figure 1), according to Vorkapic, Ocic, Kurcubic and Jovanovic (2008). In this developed process all by-products like air and water pollution and scrap material are eliminated. Also, this process is independent in technological way, which means that necessary energy is provided from hydrocarbon waste recycling process itself. Researches and all relevant technical-technological data regarding this process are checked in the constructed pilot unit for rubber and plastic recycling. All laboratory analysis was carried out.

Main advantages of new rubber and plastic recycling process in relation to used procedures are:

- complete elimination of bad impacts on the environment;
- pyrolysis oil (PO) yield is tripled, i.e. total liquid hydrocarbon yield is about 45% wt; in other known processes liquid yield is in between 15 and 18%. From PO can be distilled naphtha approx 15% and diesel fraction approx 85%;

- decrease of capital and current investment for the construction and maintenance of stationary reactor, against rotary (kiln) furnaces;
- complete energy independence i.e. heat required for pyrolysis process is obtained from process itself. Externally, energy for shredders and rotary equipment electric motors is to be obtained;
- unlimited capacity flexibility.

Transformation process of waste rubber and plastic into the commercial products is enabled by continuous process of low-temperature pyrolytic recycling, under mild pressure (Figure 2). Raw material (rubber and/or plastic) is prepared in section for preparation/cutting in 50x50 mm pieces or cryogenic procedure. Rubber pieces, prepared in this way, are put into the reactor, where under slight vacuum and increased temperature, their pyrolysis is performed. Solid pyrolysis residue, i.e. carbon black and steel belts are sent from the reactor bottom to the storage. Pyrolysis gas phase from the reactor overhead is sent through the condensers, where are

cooled down and liquefied, to the pyrolysis oil storage. Non-condensed gases from the reactor overhead stream are sent to reactor firebox, where required reaction heat is being obtained. Process itself has no harmful impact to the environment whatsoever, i.e. without any harmful chemical emission to the waste water system and/or air. At the outlet of this new technological process for rubber and plastic recycling, the following products are obtained:

- fuel gas;
- naphtha;
- diesel fraction;
- carbon black; and
- steel from the steel belts and beads.

FIGURE 1. THE TRANSFORMATION PROCESS

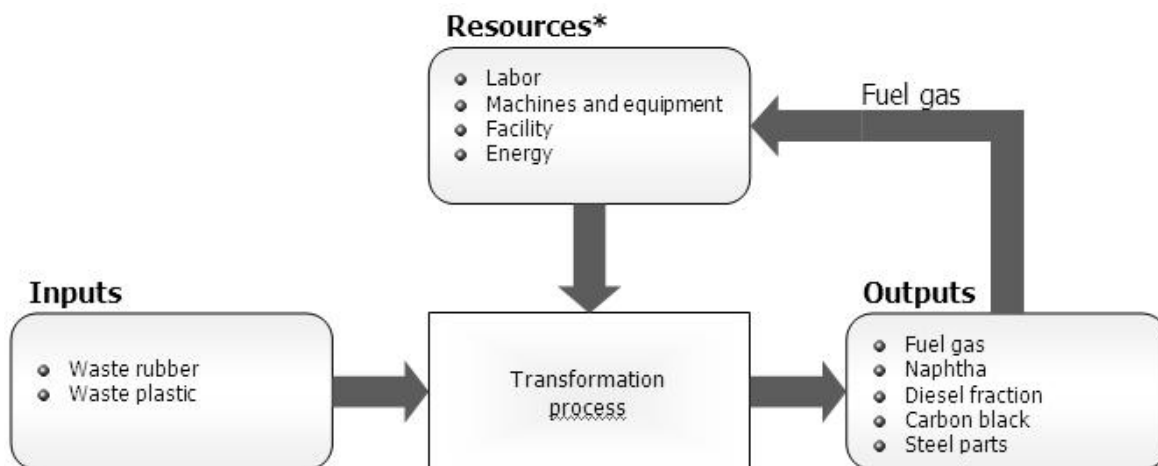

\* Capital is omitted, because it is not a direct resource

**Fuel gas** is used as a power source for its own consumption, which enables energetic optimization and closing of the technological process. Amount obtained from the process is approx. 10%, which contains small amount of sulphur, which is scrubbed from the flue gas prior to sending to atmosphere.

**Naphtha** can be used as the auxiliary means in rubber industry. Yield is approximately 5%.

**Diesel fraction** can be used for supplying the regional public utility companies, systems of smaller capacity central heating, industries, mechanization and dryers in agriculture. By the change of process parameters in technological recycling process, it is possible to change basic physical-chemical characteristics of naphtha and diesel fraction, for example scope of distillation, ignition point, cetane number,

and to get the appropriate quality in that way. Yield is approximately 35 - 40%.

**Carbon black**, which is basically pure hydrogen, can be used as the means for reduction in metallurgic processes of melting the steel in high furnaces (coke substitute), and as a power source in cement factories and foundries. Also, after the additional refining it can be used as filler in plastic industry or as a pigment. Yield of carbon black in relation to inlet raw material is about 35 - 40%.

**Steel parts** can be used as a secondary raw material in metal production. Yield of steel parts in relation to inlet raw material is about 10%.

Necessary equipment for construction of the unit for waste rubber and plastic recycling consists of the following: reactor, separators, ejector, scrubber, pumps and measuring-control instruments. At the unit entrance preparation is performed in

such way that pulverization of rubber and plastic is done by a cutting tool. In the reactor under the mild vacuum rubber and plastic pyrolysis is performed. Scrubber is used for removal of uncondensed hydrocarbon phase before it is directed to the reactor firebox. Separator of the gas phase is used for separation of gas hydrocarbon phases. Separator of liquid phase is used for separation of gas and liquid phase. Liquid hydrocarbons are directed into the storage area via pump. Ejector enables the separation of phases in the separator. Besides that, there are inlet and outlet chamber, firebox and pumps.

**Proposal for construction and commissioning the units for waste rubber and plastic recycling: The case of Serbia**

There are layers of hundred thousand tons of waste rubber and plastic on the waste-dumps, at the periphery of urban areas, as well as near the industrial areas, in Serbia. According to Serbian Environmental Protection Agency (2006), in the territory of the Republic of Serbia, there are 164 waste-dumps located, which are used by municipal public utility companies for disposal of the waste. The waste rubber is disposed on 117 waste-dumps, while disposal of the waste plastic is performed on 159 waste-dumps. Data regarding quantities and types of the waste disposed on the waste-dumps are not available, because the records are kept on 30 (18.3%) waste-dumps only.

FIGURE 2. BLOCK DIAGRAM OF WASTE RUBBER AND PLASTIC RECYCLING PROCESS

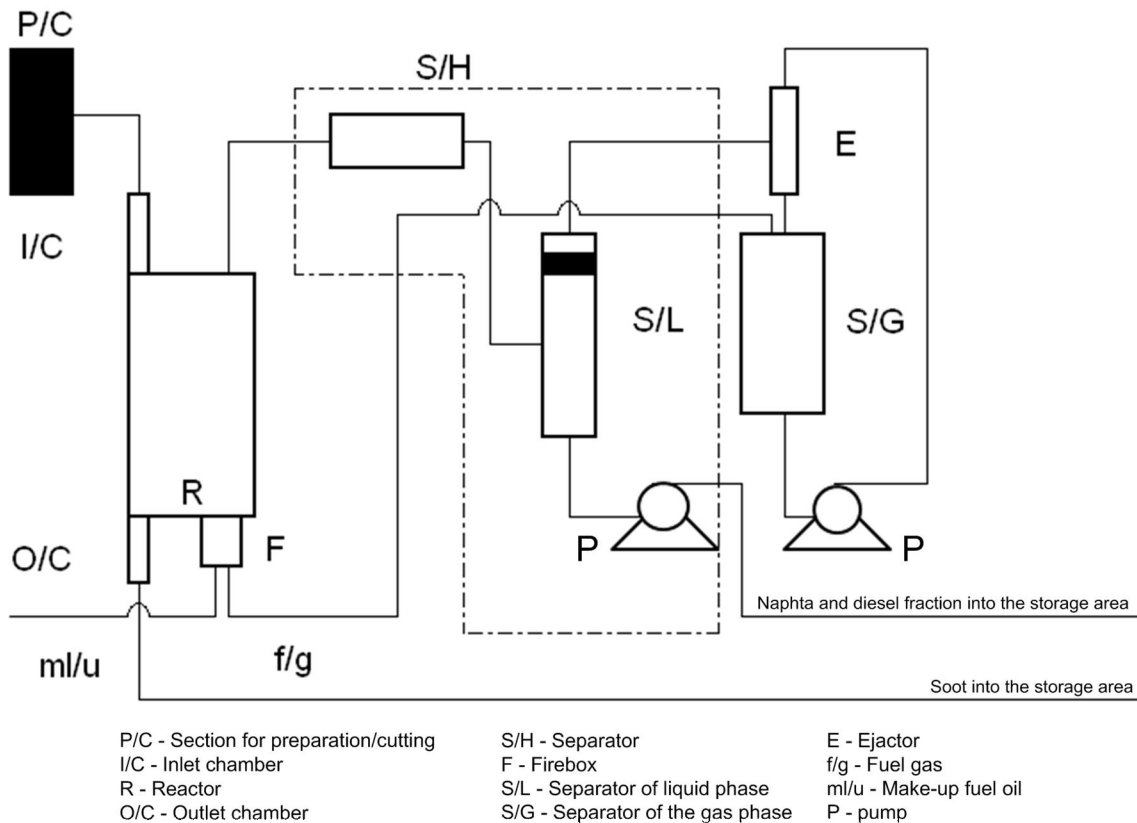

Problem of waste rubber and plastic in Serbia can be solved by construction and operation of the unit for waste rubber and plastic recycling. Results, which could be achieved, in connection to the environmental policy, firstly refer to prevention of air pollution and contamination of water sources. From economic point of view, economic disequilibrium of the state would be improved (i.e. export-import ration), because all products, which are the results of this unit operation, are completely or partially scarce in

Serbia. At the same time, all conditions for obtaining the European standards would be fulfilled, which is one of the prerequisites for a state to become a member of European Union.

Short-term aim is the construction of the waste rubber and plastic recycling unit at the territory of Belgrade, near city waste-dump in Vinca. After commissioning, 10% increase in profit is expected at annual level, and on these bases, financial

means for new investments would be provided. In medium-term plan, the aim is the unit construction near towns with developed rubber industry. In Vojvodina, it would be Ruma, in central Serbia, it would be Krusevac, and at the southeast, it would be Pirot. Long-term plan is unit construction in Banat, Backa, Macva, Bor, Pomoravlje and Zlatibor counties, as well as the transfer of knowledge and technology (know-how) to other countries of Middle and Southeast Europe.

Business plan for construction and put a facility for waste rubber and plastic recycling into operation on municipal territory of Belgrade, near the city waste-dumps in Vinca, is realized for period from year 2007 to 2013 (Vorkapic, Ocic, and Kurcubic (2006)). Total investment in this facility is estimated on 400 000 Euro. Investment encompass license, making of basically and detail engineering, providing site, equipments, buildings, assembly, training of people and providing all necessary capital goods. Quantification of business operations' income and expenditure is based on presented technical-technological solution and values in Euro. These calculations of income and expenditure have been performed according to the economic conditions at the time of Business plan preparation and in accordance with the current regulations in Serbia. Total revenue encompasses incomes which will be realized with sales of naphtha and diesel fraction, carbon black and steel parts. In the first business year total revenue is about 421 250 Euro, and every next year they will be increase for 15% in relation with forecast of advance naphtha and metals. Total expenditure encompasses expenses for materials, cost of energies and fuel, amortization, labour cost, cost for research and development and interest, marketing cost, and taxes. In the first business year total expenditure is about 291 250 Euro, and every next year they will be increase in relation with projected inflation for 5%. These data are obtained for the industrial facilities 990 t per annum. Technological life of the facility is 10 years. Balance sheet (calculation of income and expenditure) is projected for the first 5 years of project life and conclusion is: balance sheet is positive in all years for regularly working facility.

Project static and dynamic assessments were used for the project evaluation. Calculated static payback indicator is 4 years. Since the unit technological life of project is at least 10 years, it can be concluded that, from this viewpoint, the project is justified. The activation period, also called the investment immobilization period, in this project is 1 year. This project will earn the income of 0.02 € per unit of the funds spent for making this income. The general economy requirement is that this indicator should be above one, i.e. the income earned should be higher than the funds invested, so we can conclude that this project meets the economy criteria. The annual net effect (profit) of 0.05 Euro will be made per unit of the funds invested in this project. The general requirement is that the cost effectiveness indicator shall be positive. Technological development project shows the acceptable cost effectiveness. The result shows the profitability of 31%. Therefore, 31 % of income is the profit of the company after taxes, and it means that the project is profitable.

The dynamic process assessment is made on the basis of the project economic flow. The internal rate of return is 42%, and it is much higher than interest rate (in this particular case,

the interest rate is 8%), so it can be concluded that the project is cost effective and that project investments are justified. For more details see Vorkapic, Ocic, Kurcubic and Jovanovic (2008). General conclusion is that the investment in facility for waste rubber and plastic recycling is justified according all parameters.

## Conclusion

Construction of the unit for complete decomposition of waste rubber and plastic to commercial products (fuel gas, naphtha, diesel fraction, carbon black and steel parts) enables solving the problem regarding waste rubber and plastic in the effective and efficient way. Investments in the construction and commissioning of such units, besides contribution to protection and preservation of the environment, are also justified in connection to expectations regarding achievement of positive economic results in designed technological lifetime of the unit. Challenges, which lie ahead in future period, are related to providing necessary financial means for construction and commissioning of such units for waste rubber and plastic recycling.

## References

- Ocic, O., 2004. Oil refineries in 21st century: Energy efficient, cost effective, environmentally benign, Weinheim, Germany: Wiley-WCH, Germany.
- Serbian Environmental Protection Agency, 2006. "Report on the state of the environment in the Republic of Serbia 2005", Belgrade, Serbia. Retrieved November 29, 2009, from [http://www.sepa.sr.gov.yu/download/Izvestaj\\_o\\_stanju\\_zivotne\\_sredine\\_2005.pdf](http://www.sepa.sr.gov.yu/download/Izvestaj_o_stanju_zivotne_sredine_2005.pdf) (in Serbian).
- Vorkapic, R., Ocic, O. and Kurcubic, L., 2006. "Business plan", Competition for the best technology innovation in 2006 in Serbia (in Serbian).
- Vorkapic, R., Ocic, O., Kurcubic, L., and Jovanovic, B., 2007. "Tyre recycling pyrolytic process innovation", The Fifth Conference of Businessmen and Academics SPIN 2007, Belgrade, Centre for Operations Management, Conference Proceedings, pp. 48-52.
- Vorkapic, R., Ocic, O., Kurcubic, L., and Jovanovic, B., 2007. "New pyrolytic tires recycling process", International Conference Innovations and Health and Safe Human Environment, 29th and 30th November, SASA, Belgrade, Book of abstracts, p. 41, Supplement: CD with Papers ISBN 978-86-910813-0-0, Belgrade association of inventors and authors of technical improvements, Belgrade, Serbia.
- Vorkapic, R., Ocic, O., Kurcubic, L., and Jovanovic, B., 2008. "Solving the problem regarding waste rubber and plastic in Serbia", Proceedings of the Global Business Innovation and Development Conference GBID "Innovation and Development for Economic Growth in the Global Environment", Rio de Janeiro, Brazil, pp.350-356.