



**AgEcon** SEARCH  
RESEARCH IN AGRICULTURAL & APPLIED ECONOMICS

*The World's Largest Open Access Agricultural & Applied Economics Digital Library*

**This document is discoverable and free to researchers across the globe due to the work of AgEcon Search.**

**Help ensure our sustainability.**

Give to AgEcon Search

AgEcon Search

<http://ageconsearch.umn.edu>

[aesearch@umn.edu](mailto:aesearch@umn.edu)

*Papers downloaded from **AgEcon Search** may be used for non-commercial purposes and personal study only. No other use, including posting to another Internet site, is permitted without permission from the copyright owner (not AgEcon Search), or as allowed under the provisions of Fair Use, U.S. Copyright Act, Title 17 U.S.C.*

*No endorsement of AgEcon Search or its fundraising activities by the author(s) of the following work or their employer(s) is intended or implied.*

## A SYSTEMS APPROACH TO PEST CONTROL RESEARCH

Robert P. Jenkins\*

### WHY SYSTEMS ANALYSIS

Systems analysis would be a useful tool for certain kinds of pesticide research, particularly that involving decisions affecting the environment or the ecosystem. A well-designed systems analysis would permit researchers and policymakers to learn more about the complete effects of their decisions relating to pesticides. It is doubtful whether any one person or group of persons can mentally formulate all the complex effects of a pesticide on the environment, on optimum farm organization and practices, on human welfare, and on the myriad of other interrelated factors.

It is being increasingly recognized that to evaluate the effects of pesticides, a systems approach is necessary. Referring to pesticides and animal wastes, "a joint USDA-State Task Force reviewed current research programs, needs and opportunities in 1968-. . . The task force clearly saw the need for systems analysis in solving pollution problems" (associated with pesticides) [1].

### SYSTEMS ANALYSIS CONCEPTS

We will first discuss the concept of a system and then the use of systems analysis in research. Some promising levels of systems analysis relating to pesticides will be identified and, lastly, development of one of them initiated.

The word "system" is at the heart of this discussion. When used in the framework of the research methodology commonly referred to as "systems analysis," it is defined [2] as "a set of objects together with relationships between the objects and between their attributes." "Attributes are properties

of objects and any object can be described by listing its attributes."

Within any system, many subsystems exist. All systems are subsystems of the next higher one. This is particularly obvious for pesticide research. The major hierarchies of subsystems for studying pesticide effects are discussed in the section which follows.

A system is in equilibrium if in the absence of external shock (environmental change) the system remains unchanged, or after external shocks are received it returns to the position occupied before the shock.

### USING SYSTEMS ANALYSIS IN RESEARCH

How can one scientifically use systems analysis as a pesticide research methodology? The first step is to observe and delineate events in the system. The second step is to build a model (hypothesis) describing the relationships believed to exist in the system. (Because systems analysis depends so heavily on computer technology and is so integrally related to it, the model usually is called an algorithm or an arithmetic-logic sequence of events.) The model should (1) account for all known facts, and (2) help make predictions which can be tested by any unbiased independent observer. The final step in using systems analysis is to evaluate the model (test the algorithm) using real world data.

A process called *simulation* is one application of systems analysis which seems particularly appropriate for pesticide research. Simulation is a means of modeling reality. To simulate means to duplicate the behavior of the system or activity under study without actually attaining reality itself. A model is developed which—"can be manipulated to describe a

\*Agricultural economist, Farm Production Economics Division, Economic Research Service, U. S. Department of Agriculture, Washington, D. C.

dynamic process in a specified environment for which formal mathematical analysis is an impractical and inefficient way of getting answers" [3]. The model is varied for testing and experimentation rather than the real world. This is in contrast to ordinary scientific experiments where the real world circumstances (test plots) are varied.

Simulation is appropriate for problems having three basic characteristics, all of which exist in the problem of choosing an appropriate pesticide policy. First of all, it works most efficiently with complex systems. Second, it is particularly useful where random variables exist which are difficult to measure with any certainty. Third, it is useful where the relationships are not mathematically tractable.

A great advantage of simulation models is flexibility. They are not subject to rigid mathematical constraints such as are required in linear programming. Although they are not usually optimizing models, they can show the path toward the optimum by appropriate variation and testing of the parameters of the model.

## PESTICIDE RESEARCH SYSTEMS

There are at least five different levels at which a model for analysis of a pesticide research system can be developed. They have been given the following designations beginning with the highest level and proceeding to the lowest: (1) The Ecological System, (2) The Production System, (3) The Enterprise System, (4) The Pest Control System, and (5) The Chemical Control System.

### The Ecological System

The highest order of these systems is an ecological system. A study of this system would involve such matters as the relationship between plants using carbon dioxide and giving off oxygen with animals using oxygen and giving off  $\text{CO}_2$ . It would involve both farm and nonfarm variables and would be concerned with the balance of nature, the food chain, oxygen levels in water, the relationship of green space to the total land area, the health of the peregrine falcon and other such environmental variables. Obviously, this system, while by far the most complex, represents the ultimate way to analyze the pesticide problem.

The only disadvantage of a simulation model at this level would be the extremely large input of time and effort required to make it operational. The ecosystem is so complex that millions of interrelated decisions would have to be considered.

### The Production System

A second level system, slightly lower than the above, can be labeled a production system. Here the concern in the aggregate is about how food is to be produced, what crops and animals shall be produced, how shall the agricultural water and the soil be used to most effectively conserve and benefit from them. Obviously this system is oriented more closely to the traditional USDA and Land Grant Agricultural College spectra of concern than the ecological model described above.

To use the production system in simulation, the problem of how agriculture should be organized to maximize satisfaction to consumers, and maximize profits to producers must be considered. One pest related question is, what level of control is most economical in the aggregate production scheme? This model would be considerably simpler than the ecological model. However, the question of overall environmental pollution might not be considered fully.

### The Enterprise System

Coming down the systems ladder a third type might be an enterprise system where the amounts of available machinery, labor, pesticides, etc. on an individual farm would be studied to insure their most effective use in producing any given crop, livestock, or other enterprise on a particular farm. The questions would concern the enterprises that an individual farmer should produce and how he should produce them. Linear programming and simpler methods such as budgeting may be more appropriate than simulation models for some problems at this level.

### The Pest Control System

An even lower level systems analysis might analyze pest control systems. Here the choice would be between alternative control measures available to the individual producer, such as manual control, chemical control, rotation of crops, biological control, spacing of plants, date of planting, production of resistant varieties and others. This seems to conform closest to a system of "integrated weed control" now espoused by biological scientists. These decisions could possibly be made more efficiently by simpler models than simulation, although many complex, interrelated variables still must be considered even at this relatively simple level.

### The Chemical Control System

The lowest level of systems analysis which seems useful could be called chemical pest control. The major components of this system are simply a set of

chemicals and devices to apply them. The only basic questions here are what chemicals should or can be used, how should they be applied, and under what circumstances. In the past some recommendations to farmers have been made at this level.

Obviously simulation is not the most effective technique to use at this level since a well-trained scientist often can mentally solve this system more accurately and quickly than a computer.

Many people would object to this system as unrealistic. But, is it? Given the current minimum restraints placed by society on pesticide use, and the current levels of pesticide prices, chemical alternatives are nearly always the most profitable. Then why should farmers and extension specialists use or recommend nonchemical alternatives if their only constraint is production of food and fiber at the lowest possible cost? Individual farmers should not be expected to exercise the social conscience of total society. Society must define its goals more clearly and cause pesticides to be used in a way that will help advance those goals.

### Developing the Ecological Model

Several levels of systems usable for evaluating pesticide policy have been outlined in the preceding section. Obviously there are economic, social, legal, and technological decisions which must be made at each system level. The answers become more complex as one moves toward the higher systems. But, they also become more relevant to the total society.

Proceeding to the development of a model for this ecological system, one judges that the basic purpose and goal of a national pesticide policy would be to maximize net social welfare or equivalently to find a basic pesticide policy that will be the best for all people. Obviously the best efforts of entomologists, weed scientists, horticulturalists, agronomists, economists, ecologists, medical personnel, and others will be required to develop a system to implement this policy.

Ideally, a system should be developed which would permit anyone concerned with pesticides to test any policy or pesticide recommendation to see what its effects would be on environment, on human health, on farm income, and on net social welfare as the policy or recommendation is carried out through time.

The first major step in simulating an ecological system, assuming a problem has been identified (e.g. possible adverse pesticide effects on the environment), is to determine the nature of subsystems involved in the system and to develop flow charts

showing the nature and direction of activities and relationships. As a beginning, six of the basic interconnected subsystems composing the ecological system are outlined in Figure 1. They have been entitled: Agriculture, Government, Environment, Human, Commercial and the World. The relationship of these subsystems to each other depends on one's point of view. Viewed from the standpoint of agriculture (Figure 2), the major component is the agricultural sector with the other subsystems of less significance. The other subsystems are dependent on agriculture. Therefore the needs of agriculture must receive top priority from this viewpoint with other subsystems being subordinated to the needs of agriculture.

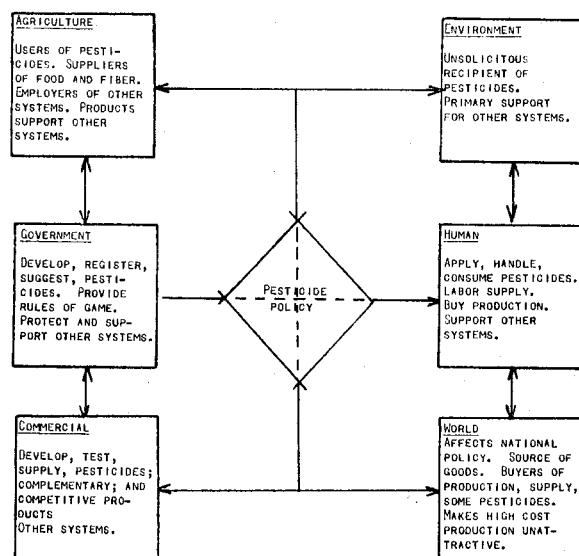

FIGURE 1. SUBSYSTEMS INVOLVED IN A SIMULATION APPROACH TO PESTICIDE POLICY

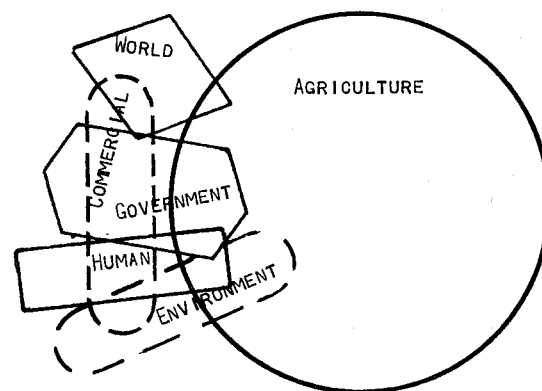

FIGURE 2. SCHEMATIC DIAGRAM OF THE ECOLOGICAL MODEL VIEWED FROM AN AGRICULTURAL VANTAGE POINT

The ecologist sees things differently. Viewed from his vantage point, Figure 3 shows a logical perspective. From this position, the environment appears to be the major component with the other subsystems largely dependent on the correct functioning of the environment. This implies that it must receive first consideration, often at the expense of the other subsystems.

Which of these two viewpoints one holds largely determines his position on the current controversy about pesticides. It may carry over into differences between government agencies or even college departments as a reflection of their differing missions.

The agricultural subsector has been lifted out and a preliminary flow chart developed which shows the direction of the relationships within this one subsystem (Figure 4). This model would be much simplified if the amount and location of production could be treated as parameters exogenous to the model.

Each of the pesticide use decisions requires branching to a pesticides subroutine shown in Figure 5. This figure shows in detail, but with considerable condensing, the subroutine required simply to simulate the farmer's economic decision as to whether a pesticide should be used (disregarding other considerations).

An optional test for Federal pesticide registration is shown in Figure 5. This test could be suppressed for pesticide development work. But for many policy decisions it is one of the most important considerations, since it is the Government's primary means of regulating pesticide use.

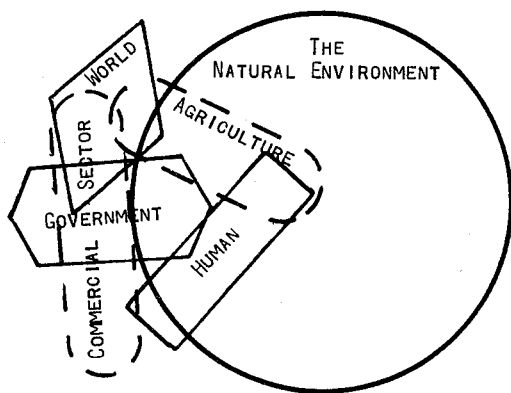

FIGURE 3. SCHEMATIC DIAGRAM OF THE ECOLOGICAL MODEL VIEWED FROM AN ENVIRONMENTAL VANTAGE POINT

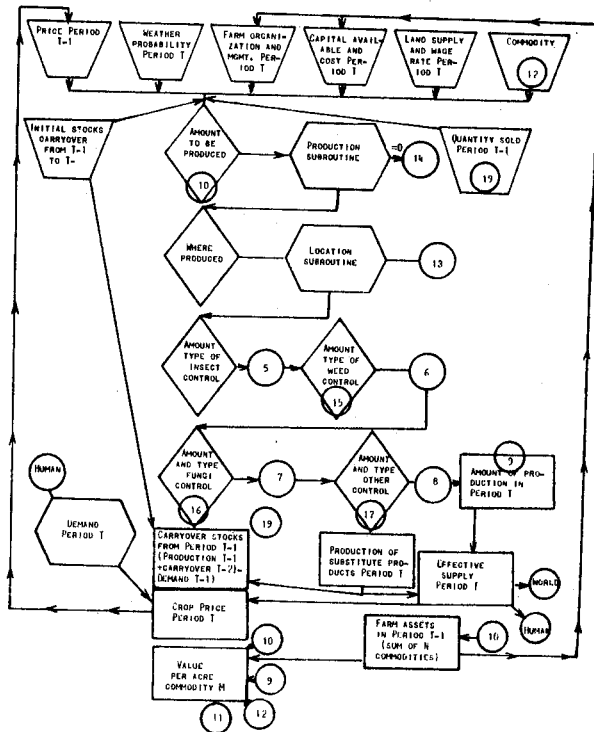

FIGURE 4. AGRICULTURE SUBSYSTEM

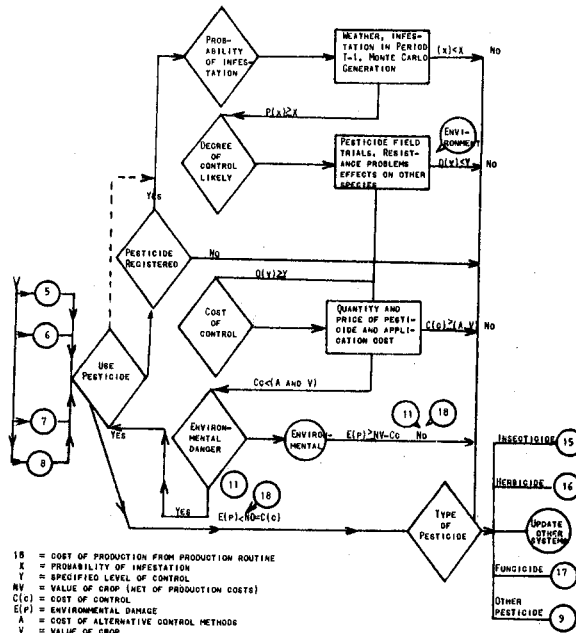

FIGURE 5. PESTICIDE SUBROUTINE

No attempt has been made to specify either type or magnitude of the functional relationships and frequency distributions involved in this preliminary work. This is where some research effort needs to be concentrated. Many interconnecting links to other subsystems are needed to use even this one small pesticide subroutine (Figure 5). This indicates the vastly complicated problem that any simulator would have in developing a model of the ecological system.

Since a simulation model of the ecological system would be so large and complex, perhaps the total requirement should be split into manageable pieces

and assigned to interested research teams at state universities and in USDA. Industry personnel should be included whenever useful. It would be most desirable if environmental and ecological specialists from the Department of HEW and Interior and other agencies could also be involved.

Developing this model would be costly and time consuming but the results would more than make up for this cost by their contribution to a cleaner environment, more efficient production, and faster, more complete responses to national pesticide policy questions.

#### REFERENCES

1. Dr. T. C. Byerly, "The Environment and Agriculture," paper delivered at the 1970 National Agricultural Outlook Conference.
2. McMillan, C. and R. Gonzalez, *Systems Analysis, A Computer Approach to Decision Models*, Richard D. Irwin, Inc., 1968.
3. Halter, A. N. and S. F. Miller, "Simulation Techniques and Their Application to Economic Research," unnumbered mimeo.

