



AgEcon SEARCH

RESEARCH IN AGRICULTURAL & APPLIED ECONOMICS

The World's Largest Open Access Agricultural & Applied Economics Digital Library

This document is discoverable and free to researchers across the globe due to the work of AgEcon Search.

Help ensure our sustainability.

Give to AgEcon Search

AgEcon Search

<http://ageconsearch.umn.edu>

aesearch@umn.edu

*Papers downloaded from **AgEcon Search** may be used for non-commercial purposes and personal study only. No other use, including posting to another Internet site, is permitted without permission from the copyright owner (not AgEcon Search), or as allowed under the provisions of Fair Use, U.S. Copyright Act, Title 17 U.S.C.*

No endorsement of AgEcon Search or its fundraising activities by the author(s) of the following work or their employer(s) is intended or implied.

FARMERS' RESPONSE TO THE COMMODITY CREDIT CORPORATION'S LOAN PROGRAM

Ronald R. Miller, William H. Meyers, and Michael A. Lancaster

The Commodity Credit Corporation (CCC), established by Executive Order in 1933 and granted a federal charter in 1948, is authorized to extend nonrecourse loans to farmers who use agricultural commodities from the most recent harvest as collateral. The loan program was designed to foster a more orderly marketing procedure and stabilize agricultural prices and income, but farmers also use this program as both a residual market and a speculation and marketing aid. The amount loaned to a farmer equals the quantity of the commodity pledged as collateral times a fixed per unit value (loan rate) which is announced prior to the production period. Eligibility of a farmer for a CCC loan may require compliance with USDA allotment or set-aside programs and storage of the commodity in a CCC approved facility. The CCC's commodity demand via the loan program is perfectly elastic at the loan rate and farmers can supply as much as they desire. When the loan matures the farmer can either repay it with interest or default on both principal and interest, in which case the CCC assumes ownership of the pledged commodity.¹

As a federally chartered corporation, the CCC receives its program funds from the U.S. Treasury, and estimates of quantities put under loan with the CCC are important inputs to the budgetary process.² Loan activity has been especially volatile in the 1970s, and a procedure for forecasting loan volume should prove useful for more efficient budgeting, program staffing, and administration.

The first section of this article presents a behavioral model for quantities of commodities put under loan with the CCC. In the second section, econometric specifications of the behavioral model are formulated and equations are developed and used to estimate quantities of corn and wheat put under loan.

THEORETICAL DEVELOPMENT

Although much has been written about the history, administration, and effects of the Commodity Credit Corporation's loan program, little quantitative research on loan activity has been reported. Recent studies by Chennareddy and Holmes [1, 2] provide some empirical relationships but do not include an underlying behavioral model or economic rationale. In this section, a behavioral model is derived in which profit maximizing behavior on the part of producers is assumed.

Figure 1 is a representation of marketing

FIGURE 1. FARMER'S MARKETING ALTERNATIVES

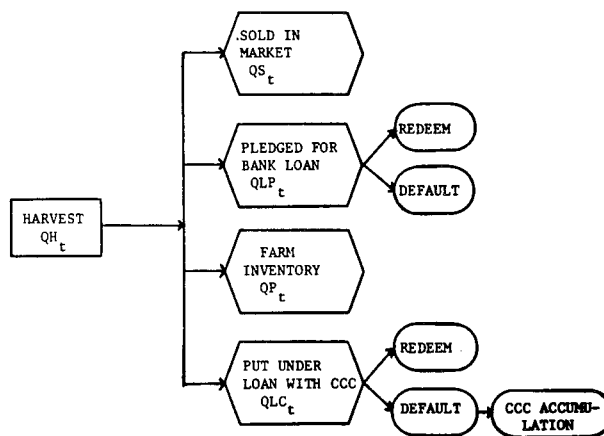

alternatives available to crop producers at harvest.³ At time t , a producer may decide to sell a portion (Q_S) of his harvest, to use a portion (Q_{LP}) as collateral for a bank loan, to hold a portion (Q_P) of the grain privately without pledging it as security for a loan, or to put a portion (Q_{LC}) under loan with the CCC. The

Ronald R. Miller is Economist, Agricultural Policy Analysis Program Area, William H. Meyers is Agricultural Economist, Forecast Support Group, and Michael A. Lancaster is Economist, Forecast Support Group, Commodity Economics Division, Economics, Statistics, and Cooperative Service, U. S. Department of Agriculture.

¹Under the Food and Agriculture Act of 1977, farmers who have maturing wheat or coarse grain loans now have the added option of joining the producer-held reserve program.

²Although other quantities such as loans defaulted and direct purchases by the CCC also affect CCC-related Treasury outlays, only amounts put under loan are directly considered in this article.

³The focus of this article is on quantities of a given crop put under loan with the CCC in a given year. Given this focus, emphasis is placed on identifying the major behavioral factors affecting the farmer's decision process at the time of harvest. Accordingly, such issues as disposing of quantities stored from previous crop years or options of participating in resale or producer-held reserve programs in future years are not analyzed.

sum $(QS_t + QLP_t + QP_t + QLC_t)$ must equal the farmer's harvest (QH_t) . The producer is assumed to choose these four quantities so as to maximize his profit. Without loss of generality, the producer also can be assumed to hold all unsold quantities until the $(t + n)^{th}$ time period at which point the commodity is either sold in the market or defaulted to creditors.⁴

The following additional notation is used.

P_t = price of the commodity in time t
 LRP_t = loan rate granted by private financial institutions in time t
 LRC_t = loan rate granted by the CCC in time t

S_n = storage rate for n time periods
 IRP_t = interest rate charged by private financial institutions in time t
 IRC_t = interest rate charged by CCC in time t
 QDP_t = quantity defaulted to private financial institutions in time t
 QDC_t = quantity defaulted to the CCC in time t

Producers' cash receipts from loans and market sales for a given crop in time period t are:

$$P_t QS_t + LRP_t QLP_t + LRC_t QLC_t.$$

Storage cost for n time periods is given by:

$$S_n(QLP_t + QP_t + QLC_t).$$

The cost of redeeming loans in the $(t + n)^{th}$ time period is:

$$(1 + nIRP_t)LRP_t(QLP_t - QDP_{t+n}) + (1 + nIRC_t)LRC_t(QLC_t - QDC_{t+n}).^5$$

Revenue from market sales of quantities sold in time period $(t + n)$ is:

$$P_{t+n}[(QLP_t - QDP_{t+n}) + QP_t + (QLC_t - QDC_{t+n})].$$

If the producer had perfect knowledge of future prices and did not have institutional constraints or cash flow requirements, he would maximize his profit from his harvest by selling when $P_{t+n} - P_t \leq S_n$ and storing the commodity privately without pledging it as

collateral for a loan when $P_{t+n} - P_t > S_n$.⁶ Under these circumstances farmers would not find it profitable to enter into loan agreements with either public or private creditors. However, a farmer generally has regular financial obligations which preclude withholding his production from the market without some type of loan.

If the producer attempts to meet his financial obligations or incur additional commitments without resorting to government programs, his decision criterion for profit maximization given the maintenance of a cash flow, say C_t , is:

$$(1) \text{ Obtain loan } QLP_t = \frac{C_t}{LRP_t}$$

$$\text{Hold privately } QP_t = QH_t - QLP_t$$

$$\text{if } (P_{t+n} - P_t) \geq S_n + (nIRP_t LRP_t)$$

$$(2) \text{ Sell } QS_t = \frac{C_t}{P_t}$$

$$\text{Hold privately } QP_t = QH_t - QS_t$$

$$\text{if } S_n < (P_{t+n} - P_t) < S_n + (nIRP_t LRP_t)$$

$$(3) \text{ Sell } QS_t = QH_t$$

$$\text{if } (P_{t+n} - P_t) \leq S_n.$$

In the foregoing analysis, private financial intermediaries are implicitly assumed to be willing and able to loan funds to producers. In times of low or unstable prices, when loans are most needed by farmers, private lending institutions may not be willing to make commodity loans. The CCC loan program gives the farmer an additional alternative.

If the producer attempts to use the CCC loan program instead of private financial intermediaries, his profit maximizing decision criteria would be the same as those specified in equations 1, 2, and 3 with LRC_t , IRC_t , and QLC_t substituted for LRP_t , IRP_t , and QLP_t , respectively. Because the interest rate charged by the CCC is less than that charged in the private sector and the CCC's commodity demand is always perfectly elastic at the loan rate, commodities would not be used as collateral for a loan in the private sector if there were no institutional constraints within the CCC loan pro-

⁴The empirical analyses in the next section are based on yearly time periods and $n = 1$.

⁵For an individual farmer, the amounts QDP_{t+n} and QDC_{t+n} will generally be either zero or the total amount pledged as collateral. However, in the aggregate only the following inequalities need apply.

$$0 \leq QDP_{t+n} \leq QLP_t$$

$$0 \leq QDC_{t+n} \leq QLC_t$$

⁶For simplicity, transaction, transportation, and opportunity costs are not explicitly brought into the analysis. The variable S_n can be defined to include these factors.

gram. However, to be eligible for the CCC loan program, the producer is often required to comply with other commodity programs, such as acreage set-aside. A farmer may view the "package of programs" as being unprofitable although participation in the loan program alone may be profitable. An additional eligibility constraint is that commodities must be stored in approved facilities. If facilities are not available or the farmer simply does not wish to comply with all program provisions, he may have to use private creditors.

To this point, it has been assumed that the producer has perfect knowledge of prices in future time periods. As this is not the case, decisions are based on price expectations. Any decision based on uncertain price information should take price volatility, i.e., risk, into account. The producer would like to be able to minimize his loss if price is lower than expected, yet fully capture any gain resulting from price being above its expected value. The CCC loan program provides this type of assistance. If the price is higher than expected, the farmer can remove his commodity from the loan program, repay the loan with interest, and capitalize on the higher market price. If, however, price is lower, he may elect to default on both principal and interest without penalty. A loan default in the private sector would most certainly involve some penalty because the farmer's credit rating would be affected.

An additional consideration is that the producer may view income taxes as a marketing cost. It could be advantageous for the farmer to delay his marketing until a new calendar year to achieve a lower tax rate, thus lowering his expected tax bill and increasing his net return. The CCC's loan program would facilitate this type of activity.

The preceding analyses illustrate behavioral models under different assumptions about institutional constraints, cash flow requirements, and price certainty. The insights gained from these analyses lead to the identification of variables that can be expected to influence the amount of the commodity farmers put under loan with the CCC. These explanatory variables are listed in Table 1 along with the expected direction of change in the dependent variable (quantity put under loan with the CCC) associated with an increase in the explanatory variable, *ceteris paribus*. In the next section an econometric model and empirical results for wheat and corn based on the preceding analysis are presented.

ECONOMETRIC MODEL AND EMPIRICAL RESULTS

Specification of an econometric model re-

quires identification of the primary purposes for which the model is to be used, selection of data series which adequately measure the theoretical variables, and choice of a specific functional form. The model specified in this section is intended for forecasting annual quantities of crops put under loan with the CCC. Of specific interest is the response of loan activity to government policy instruments.

Empirical applications of the model are presented for corn and wheat. These crops were chosen because of their high proportion of total CCC loan activity.

Model Specification

The estimation model is specified as:

$$(4) Q_t = F(\text{PRATIO}_t, \text{IRATIO}_t, \text{RISK}_t, \text{PROD}_t, \text{PACRE}_{t+1}, \text{COMVAR}_t)$$

where

Q_t = quantity put under loan with the CCC in time period t , million bushels

PRATIO_t = ratio of the CCC loan rate to season average market price for time period t

IRATIO_t = ratio of the CCC interest rate to the average rate of interest charge by Production Credit Associations (PCA) in time period t

RISK_t = three-year moving variance of season average price (P)

$$\frac{1}{3} \sum_{i=0}^2 (P_{t-i} - \frac{P_t + P_{t-1} + P_{t-2}}{3})^2$$

TABLE 1. EXPLANATORY VARIABLES AND EXPECTED SIGNS

An increase in the explanatory variable	Expected change in dependent variable
Market price	-
CCC loan rate	+
Private sector loan rate	-
Expected price in future time period	+
Interest rate at the CCC	-
Interest rate at private financial institutions	+
Storage cost	-
Storage capacity	+
Price volatility (risk)	+
Participation rate in commodity programs	+
Cash flow requirement	+
Income deferral for tax advantage	+

$PROD_t$ = annual production in time period t , million bushels
 $PACRE_{t+1}$ = planted acreage for crop year $(t + 1)$, million acres
 $COMVAR_t$ = variable used to reflect the degree of compliance with required commodity programs

The CCC loan rate, season average market price, CCC interest rate, and RISK correspond directly to variables listed in Table 1.

Average PCA interest rate was chosen as the measure of interest rate in the private sector because PCAs handle a large number of farm loans [8].

Production measures the scale of the industry and serves as a proxy for the combined effect of cash flow requirements and income deferral.

Planted acreage for the $(t+1)^{st}$ crop year is expected to reflect producers' price expectations. Producers' intentions are reported by the Economics, Statistics, and Cooperatives Service and intermediate term forecasts can be made with existing commodity models, e.g., see [9].

The variable $COMVAR$ assumes different specifications in the wheat and corn equations. In the wheat equation, $COMVAR$ is measured by the proportion of wheat acreage allotments participating in government crop programs (PARTC). A similar specification for corn yielded poor results because of multicollinearity. A legislative dummy variable (LEDGV) which reflects the relatively stricter eligibility requirements in effect before 1971 was substituted.⁷

It is assumed that the private sector loan rate is reflected in the season average market price because financial intermediaries lend in proportion to the market value of the collateral. Storage cost and capacity variables are not included because of lack of reliable data.⁸

All variables enter the equation by separate linear relationships except those contained in $PRATIO$ and $IRATIO$. These were entered in ratio form to reduce multicollinearity, conserve degrees of freedom, and convert the variables to real terms without specifying additional deflation variables. The ratio form constrains the component variables to have elasticities that are equal in magnitude but opposite in sign.⁹

⁷LEDGV = 1 for 1960-1970; LEDGV = 0 for 1971-1975.

⁸The omission of a relevant explanatory variable will lead to specification bias if the omitted variable is correlated with the remaining explanatory variables. Because *a priori* judgments as to correlation between the storage cost and capacity variables and the remaining explanatory variables are not posited and data for empirical analysis are not available, speculation as to the sign and magnitude of any bias rests with one's intuition. The author's intuition is that the effect will be negligible. The reader is invited to make his/her own evaluation.

⁹Note, however, that price also appears in the risk variable, so the absolute values of elasticity with respect to price and with respect to the loan rate will differ slightly.

Model Estimation

The corn and wheat equations first were estimated for the period 1960-1974. Regression results are presented in Table 2. The coefficients all have the expected signs and each equation has a relatively high \bar{R} : 0.93 for corn and 0.87 for wheat. All explanatory variables in the corn equation are statistically significant at or above the 0.10 level except $IRATIO$. In the wheat equation, $IRATIO$, and $PACRE$ have coefficients which are not significant at the 0.10 level. These equations were used to predict loan volume for 1975 with the known values of the explanatory variables. The estimated quantities of corn and wheat put under loan with the CCC in 1975 were 163.1 and 37.5 million bushels, respectively; the corresponding actual values were 147.0 and 39.3 million bushels. The forecasts for corn and wheat loan volume are well within one standard error of the actual value.

The equations were refitted with the additional 1975 observations. These regression results are shown in the lower part of Table 2. Figures 2 and 3 are plots of the actual and fitted values, from equations estimated with the 1960-1975 data, for quantities of corn and wheat put under loan with the CCC. Both equations track the historical period rather well at both high and low quantity levels when actual levels of the explanatory variables are used to generate the forecasts.

The addition of the 1975 observations greatly increased the precision of the estimated coefficients with only minor effects on their magnitude. The t value increased for all coefficients except the coefficient of $PACRE$ in the wheat equation which remained essentially unchanged. All variables except $PACRE$ in the wheat equation are significant at or above the 0.1 level. The increased precision can be attributed to an increase in the overall variability of $IRATIO$ and $RISK$ due to the inclusion of the 1975 observations. These variables were relatively stable before 1972. The \bar{R} and standard error for each equation also were marginally improved. The Durbin-Watson statistics are relatively high, especially for the corn equations, but all are within the inconclusive region of the test.

The elasticities of several explanatory variables are similar for the corn and wheat equations. Both equations show strong loan rate/market price ratio effects with mean elasticities of 4.14 and 3.42 for corn and wheat, respectively. At 1977 levels of the variables the elasticities are estimated to be 1.72 and 1.64 for corn and wheat, respectively. Thus, a 10 percent reduction in the CCC corn and wheat loan rates, *ceteris paribus*, would lead to an approximate 17 percent reduction in quantities of corn and wheat put under loan.¹⁰

The elasticities for IRATIO and RISK at mean levels are also similar across equations. In absolute terms, the coefficients of IRATIO indicate that a 0.1 increase in the magnitude of the ratio of CCC interest rate to the PCA rate would lead to a 58 million bushel decrease in loan volume for corn and a 35 million decrease for wheat.

The coefficients of production for corn and wheat are 0.08 and 0.38, respectively. The relatively large difference in these coefficients may well be due to wheat farmers being less diversified than corn farmers and thus being more dependent upon the CCC loan program for cash flow requirements.

The coefficient of the price expectation variable (PACRE) in the corn equation indicates that an increase of \$0.10 in expected price of corn would lead to an increase of 12.5 million bushels in corn put under loan.¹¹ The coefficient of PACRE in the wheat equation is relatively small and not significant, possibly be-

cause of the two planting periods for wheat and the greater effect of exports on price expectations in the wheat market.

The compliance variable for corn (LEGDV) indicates that the less rigid acreage diversion requirements of the set-aside provision implemented in 1971 shifted the supply relation upward by 350 million bushels. For wheat, the coefficient of PARTC indicates that at the margin a 1 percent increase in program participation would increase wheat loan volume by approximately 4 million bushels.

Model Forecasts

The equations given in Table 2 for the 1960-1975 period were used to estimate CCC loan volume for the 1976-1977 and 1977-1978 crop years. The corn estimates are 692 and 1,110 million bushels, respectively (LEGDV=0). The wheat estimates are 460 and 678 million bushels, respectively, assuming a 100 percent participation rate. The 1976-1977 crop year estimates were made with the actual values of the explanatory variables. The assumptions used to estimate the 1977-1978 crop year are presented in Table 3. The actual values of corn and wheat loan volume for the 1976-1977 crop year were 276 and 491 million bushels, respectively. Preliminary reports indicate that as of June 1978 corn and wheat loan volume for 1977-1978 crop year was approximately 1,041 and 582 million bushels, respectively. As indicated previously, the equations fitted through

TABLE 2. QUANTITY OF CORN AND WHEAT PLACED UNDER LOAN WITH THE CCC. OLS ESTIMATES

Item	Constant	PRATIO	IRATIO	RISK	PROD	PACRE	LEGDV	PARTC	R ²	D.W.	S.E.
Period 1960-74:											
Corn:											
Coefficient	-2856.0	1921.3	-553.2	917.4	0.0803	25.44	-350.08		0.93	3.21	54.1
t statistic	(-2.95)	(9.01)	(-1.27)	(1.68)	(1.88)	(2.92)	(-4.67)				
Wheat:											
Coefficient	-1732.3	1102.0	-295.3	233.0	0.3935	3.773		427.34	0.87	3.12	47.5
t statistic	(-3.29)	(4.84)	(-0.91)	(1.89)	(3.90)	(0.88)		(2.47)			
Period 1960-75:											
Corn:											
Coefficient	-2805.8	1920.3	-581.4	952.9	0.0787	25.04	-351.84		0.94	3.23	51.1
t statistic	(4.34)	(9.56)	(3.09)	(4.13)	(2.31)	(3.88)	(-5.28)				
mean elasticity:		4.14	-0.84	0.14	0.92	4.51					
1977 elasticity:		1.72	-0.40	0.03	0.47	1.81					
Wheat:											
Coefficient	-1693.5	1112.0	-353.9	258.2	0.3788	3.778		427.41	0.89	3.15	44.9
t statistic	(-3.56)	(5.25)	(-1.71)	(3.99)	(4.92)	(0.93)		(2.61)			
mean elasticity:		3.43	-0.86	0.19	2.38	0.97					
1977 elasticity:		1.64	-0.38	0.11	1.13	0.37					

¹⁰Under the new 1977 farm legislation, the Secretary of Agriculture has the authority to reduce the loan rate by up to 10 percent if market price is within 105 percent of the loan rate. For more information, see [6].

¹¹From [9], the change in planted acreage due to a one unit change in expected price (dPACRE/dPE) is approximately 5 million acres. Thus, (dQ/dPE) = (dQ/dPACRE)(dPACRE/dPE) = (25 * 5) = 125 million bushels per dollar.

1974 provided good forecasts for the 1975-1976 crop year. The same appears to hold true for estimates for the 1977-1978 crop year from the equations fitted through 1975.

The performance for the 1976-1977 crop year is mixed. The wheat estimate is less than one standard error from the actual, but the corn estimate is far above the actual level. In spite of a rather favorable loan rate to market price ratio, farmers did not increase their loan volume much over the 1975-1976 level. The reasons for this outcome are not clear. Possibly even the very substantial increase in the loan rate that occurred in 1976 was not enough to offset the impact on farmers' price expectations caused by the steady erosion of market prices that they observed from the fall of 1974 to the fall of 1976. If they expected a continued price decline, they would tend to sell early rather than to store the crop. Whatever the explanation, the 1976-1977 behavior clearly does not conform to the pattern observed over the historical period and in 1977-1978.

The 1977-1978 forecasts imply Treasury outlays for commodity loans of \$2.22 billion for corn and \$1.53 billion for wheat. These amounts are to be repaid with interest at maturity. If a loan is defaulted at maturity the CCC assumes ownership of the commodity. Under the 1977 legislation, the farmer now has the option at the time of maturity to hold the commodity in the producer-held reserve program. This program has a 3-year duration and specific price levels that trigger the release of the reserves. Because this option is available at the time of loan maturity, the amount placed in reserve is expected to be influenced by the volume of loan activity. The reserve program, in contrast, may have an indirect impact on loan volume by making the overall "package of

programs" more attractive or by affecting market price levels. These interactions will be an interesting subject for research when sufficient data on the reserve program are available.

Forecasts for all years except the 1977-1978 crop year were made with actual levels of the explanatory variables. Use of estimated values of some explanatory variables for the 1977-1978 crop year forecast introduces an additional source of forecast error. For the purpose of this article, expected values of the explanatory variables were used to obtain point estimates of the expected loan volume. For planning and budgeting purposes the prudent policy analyst should generate a series of forecasts under alternative scenarios. This approach would serve to establish a reasonable range around the expected or most likely outcome.

Comparison with Previous Work

The principal difference between this study and that of Chennareddy and Holmes is the specification of the estimated model. In their study, all variables from the supply-utilization identity along with own market price and loan rate, prices of substitute commodities, and the PCA interest rate were allowed to enter a statistical specification via stepwise regression. The resulting specification does not include the CCC interest rate or any variable which reflects either risk or future price expectations. It does, however, include quantities consumed and exported which do not appear to be justified by theoretical considerations. In the study presented here, model specification is based on the assumption of profit maximizing behavior by producers. The authors believe that this behavioral approach provides a better foundation for forecasting and policy analysis.

The empirical results shown in Table 2 can be compared with those obtained by Chennareddy and Holmes. They state that a 10 percent increase in the ratio of market price to loan rate would decrease loan volume by approximately 14 percent for wheat and 25 percent for corn. Their statement is only a correct interpretation of their own results if the change in the ratio were due to a change in the loan rate. Because their specification also has own market price contained in other ratios, the own market price elasticities should have been presented as approximately -6.4 and -0.3, respectively, for corn and wheat. It is difficult to rationalize why market price elasticity should exceed the loan rate elasticity in the corn equation when the opposite holds in the wheat equa-

TABLE 3. ASSUMPTIONS AND FORECASTS OF CCC LOAN VOLUME, 1977/78 CROP YEAR

Item	Corn	Wheat
Assumptions:		
Season average market price	\$2.05 per bushel	\$2.25 per bushel
Loan rate	\$2.00 per bushel	\$2.25 per bushel
PCA interest rate	8.25 percent	8.25 percent
CCC interest rate	6 percent	6 percent
Production	6,367 million bushels	2,026 million bushels
Planted acreage 1978	77 million acres	66 million acres
Risk variable	0.0387	0.282
Program participation	100 percent	100 percent
Forecast:		
Quantity put under loan	1,110.5 million bushels	678.4 million bushels
Treasury outlay	\$2.22 billion	\$1.53 billion

FIGURE 2. ACTUAL AND EQUATION ESTIMATES FOR QUANTITY OF CORN PUT UNDER LOAN, 1960-1975

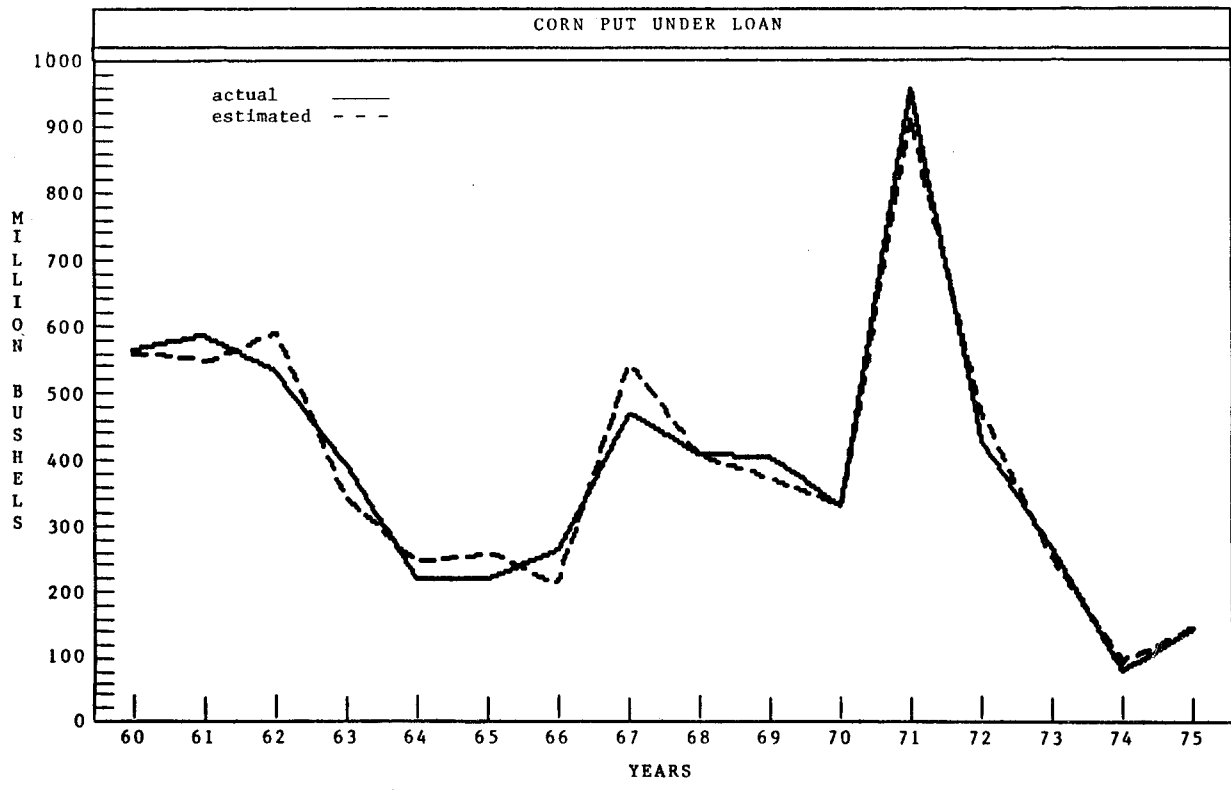
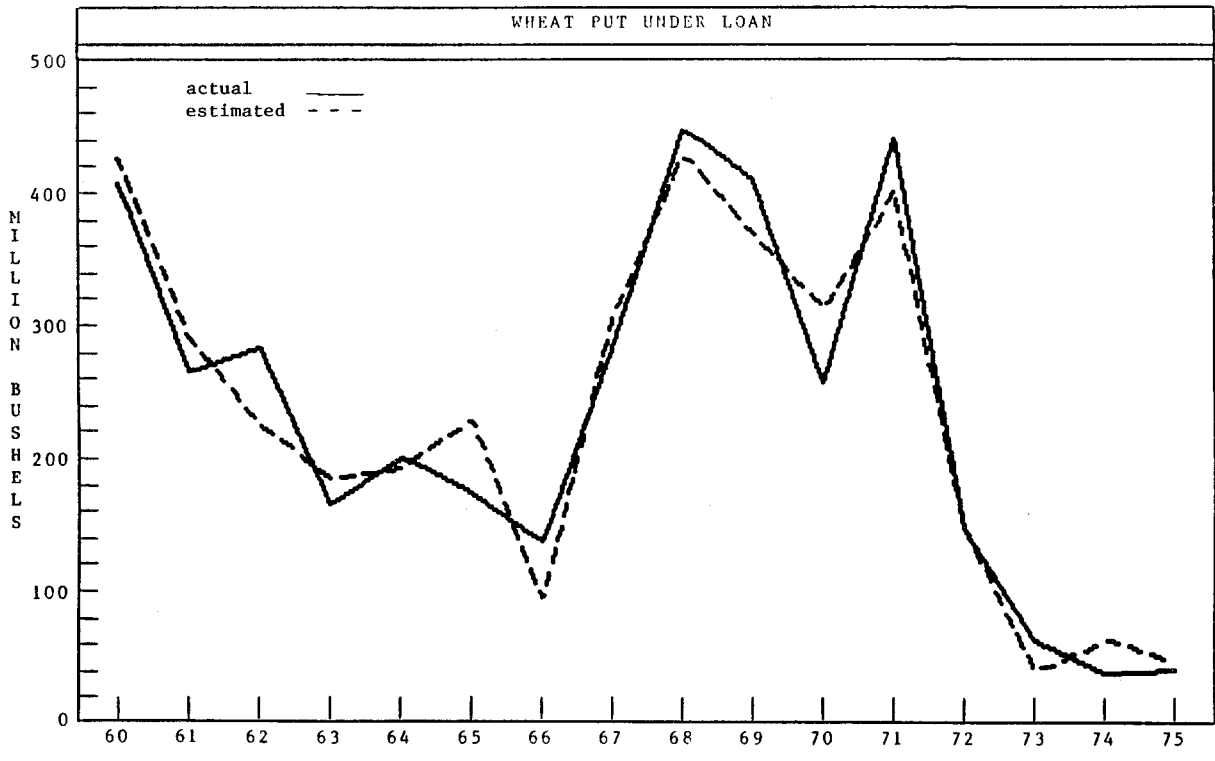

FIGURE 3. ACTUAL AND EQUATION ESTIMATES FOR QUANTITY OF WHEAT PUT UNDER LOAN, 1960-1975



tion. If the risk variable effect is included, the market price and loan rate elasticities derived by the method presented in this article are -4.31 and +4.14 for corn and -3.51 and +3.42 for wheat, all evaluated at mean values. For the other two variables common to both studies, production and PCA interest rate, Chennareddy and Holmes report elasticities of +1.99 and -0.96 for wheat and +1.21 and +2.53 for corn, respectively. Only the wheat production elasticity of +1.99 was significantly different from zero in their study. It is also noted that for wheat, their elasticity with respect to the PCA loan rate (-0.96) has the wrong sign.

SUMMARY

Prediction equations for commodities put under loan with the CCC are developed from behavioral relations assuming profit maximizing behavior by producers. The estimated equations can be used to forecast crop year

loan volume and to analyze the impact on loan volume of alternative CCC loan and interest rate levels. Alternatively, the equations can be used to determine the levels of loan and interest rates that would be associated with a desired level of loan activity.

Several topics of future research can be cited. First, the empirical results for corn and wheat suggest that the application of similar econometric models to other program crops is warranted. It would also be useful to relate the compliance variable explicitly to farm program provisions and market conditions. Additionally, a similar behavioral approach could be used to specify equations for quantities defaulted to the CCC and quantities placed in the producer-held reserve. This additional research would provide the components for a comprehensive model of price support loan activity, which would be useful not only for budget analysis but also for evaluating a broad range of policy and market interactions.

REFERENCES

- [1] Chennareddy, Venkareddy and Lloyd I. Holmes. *An Econometric Analysis of Volume of Various Commodities under Price Support Programs of the Agricultural Stabilization and Conservation Service*, U.S. Department of Agriculture, 1950-75, ASCS Report, ASCS, USDA, Washington, D.C., June-August 1976.
- [2] Chennareddy, Venkareddy and Lloyd I. Holmes. "Wheat Farmers' Demand for Commodity Loans, 1950-75," *Agricultural Economics Research*, Volume 29, Number 2, Economic Research Service, USDA, Washington, D.C., April 1977.
- [3] Cochrane, Willard W. and Mary E. Ryan. *American Farm Policy, 1948-73*. Minneapolis: University of Minnesota Press, 1976.
- [4] Hadwiger, A. *Federal Wheat Commodity Programs*. Ames: Iowa State University Press, 1970.
- [5] Houck, James P., Martin A. Abel, Mary E. Ryan, Paul W. Gallagher, Robert G. Hoffman, and J. B. Penn. *Analyzing the Impact of Government Programs on Crop Acreage*, Technical Bulletin No. 1548, Economic Research Service, U. S. Department of Agriculture, Washington, D.C., August 1976.
- [6] Johnson, James and Milton H. Ericksen. *Commodity Program Provisions under the Food and Agriculture Act of 1977*, Agricultural Economic Report No. 389, Economic Research Service, U.S. Department of Agriculture, Washington, D.C., October 1977.
- [7] Johnston, J. *Econometric Methods*, second edition. New York: McGraw-Hill Book Company, 1972.
- [8] U. S. Department of Agriculture. *Agricultural Statistics*, various issues, Washington, D.C.
- [9] U. S. Department of Agriculture. "Price Support and Other Loan, Purchase, and Payment Programs," ASCS, BI No. 4, August 1975.
- [10] Womack, Abner W. *The U. S. Demand for Corn, Sorghum, Oats, and Barley: An Econometric Analysis*, Economic Report 76-5, Department of Agricultural and Applied Economics, University of Minnesota, August 1976.