



**AgEcon** SEARCH  
RESEARCH IN AGRICULTURAL & APPLIED ECONOMICS

*The World's Largest Open Access Agricultural & Applied Economics Digital Library*

**This document is discoverable and free to researchers across the globe due to the work of AgEcon Search.**

**Help ensure our sustainability.**

Give to AgEcon Search

AgEcon Search

<http://ageconsearch.umn.edu>

[aesearch@umn.edu](mailto:aesearch@umn.edu)

*Papers downloaded from **AgEcon Search** may be used for non-commercial purposes and personal study only. No other use, including posting to another Internet site, is permitted without permission from the copyright owner (not AgEcon Search), or as allowed under the provisions of Fair Use, U.S. Copyright Act, Title 17 U.S.C.*

# Farm-level impacts of prolonged drought: is a multiyear event more than the sum of its parts?

Dannele E. Peck and Richard M. Adams<sup>†</sup>

A multiyear discrete stochastic programming model with uncertain water supplies and inter-year crop dynamics is developed to determine: (i) whether a multiyear drought's impact can be more than the sum of its parts, and (ii) whether optimal response to 1 year of drought can increase a producer's vulnerability in subsequent years of drought. A farm system that has inter-year crop dynamics, but lacks inter-annual water storage capabilities, is used as a case study to demonstrate that dynamics unrelated to large reservoirs or groundwater can necessitate a multiyear model to estimate drought's impact. Results demonstrate the importance of analysing individual years of drought in the context of previous and future years of drought.

**Key words:** crop rotations, inter-year dynamics, multiyear drought, stochastic integer programming.

## 1. Introduction

Multiyear drought is prominent throughout the world (Dai *et al.* 2004). Nearly half of all droughts in the U.S., for example, are multiyear events (Diaz 1983). Australia's Murray Darling Basin experienced 23 years of drought between 1952 and 2002, 16 of which comprised multiyear events (Nicholls 2004). Multiyear drought is expected to become even more frequent in many parts of the world, because of global climate change, population growth, and land use change (Rosenzweig and Hillel 1993; Gleick 2000; Wilhite *et al.* 2006; Meehl *et al.* 2007).

Despite the historical frequency of multiyear drought, such events have been the focus of relatively few economic studies. Studies that do address multiyear drought tend to focus on livestock grazing (Toft and O'Hanlon 1979; Thompson *et al.* 1996; McKeon *et al.* 2000), rather than crops (Iglesias *et al.* 2003). Studies of drought in crop systems focus primarily on single-year events instead (e.g. Bernardo *et al.* 1987; Bryant *et al.* 1993; Keplinger *et al.* 1998; Chen *et al.* 2001; Mejias *et al.* 2004). The lack of multiyear drought analyses for crop systems leaves readers wondering if multiyear drought can be modelled as a series of single-year events, or if multiyear analyses might provide unique insights about drought impacts in cropping systems.

---

<sup>†</sup> Dannele E. Peck (email: dpeck@uwyo.edu) is an Assistant Professor at the Department of Agricultural and Applied Economics, University of Wyoming, Laramie, WY, USA and Richard M. Adams is Professor Emeritus at the Department of Agricultural and Resource Economics, Oregon State University, Corvallis, OR, USA.

The potential for multiyear drought to generate more complex impacts than a series of independent single-year events has been raised in the literature (e.g. Clawson *et al.* 1980; Thompson *et al.* 1996; Iglesias *et al.* 2003). Clawson *et al.*, in particular, hypothesizes that a producer's response to, or recovery from, 1 year of drought may impair their ability to endure subsequent years of drought. They neglect, however, to test their hypothesis. If Clawson *et al.* is correct, producers' decisions during a multiyear drought, as well as the resulting impact, may be more dynamic and complex than previously acknowledged.

To test hypotheses about the economic impacts of single versus multiyear droughts, we develop and solve a multiyear, stochastic and dynamic programming model for a hypothetical irrigated row-crop farm. The farm faces water supply uncertainty; both the occurrence and duration of drought are known only probabilistically. Decision-making under uncertainty is made more complex by cropping decisions that generate inter-year dynamics. The producer must therefore consider not only how crops chosen in the current year will perform under alternative states of nature, but also how they will affect cropping options, and hence vulnerability to drought, in subsequent years.

Optimal farm activities (crop choice, irrigation technology, and deficit irrigation) are identified for each stage and state of the multiyear planning horizon, given uncertainty about the timing and duration of drought. Optimal farm activities and returns to land and management for various single and multiyear drought scenarios are then compared to determine: (i) whether a multiyear drought's impact is more complex than the sum of its component years' impacts, i.e. whether the impact of drought in 1 year affects the impact of drought in subsequent years, and (ii) whether optimal response to 1 year of drought leaves the producer more vulnerable to subsequent years of drought, i.e. whether a producer's effort to mitigate drought in 1 year increases the economic impact of subsequent years of drought. The economic impact of drought is measured as the difference in returns between a drought scenario and a drought-free scenario. Because an optimization approach is used in this study, rather than simulation, drought impacts reflect the producer's ability to make optimal decisions under uncertainty, and respond optimally when drought is revealed.

## 2. Case study

### 2.1 Overview

The farm-level decision model is based on irrigated row-crop farms in the Vale Oregon Irrigation District, located in a semi-arid region of the U.S. Pacific Northwest. Drought is a major source of production risk in the District; multiyear droughts have occurred there most recently from 1990 to 1992 and 2001 to 2003. The District's primary source of irrigation water is

snowmelt stored in small reservoirs that provide essentially no inter-annual carryover capacity. Reliable groundwater is not widely available in the District, and state laws deter water transfers. Producers therefore rely primarily on crop and irrigation management to prepare for and respond to drought.

Several studies address reservoir and aquifer management under inter-annual water supply uncertainty (Dudley 1988; Iglesias *et al.* 2003; Chen *et al.* 2006; Iglesias *et al.* 2007). Few, however, explore multiyear drought in crop systems that lack inter-annual water storage (Weisensel *et al.* 1991). In the absence of inter-annual water storage, a dynamic multiyear model may seem unnecessary to investigate optimal drought management. Other sources of inter-year dynamics that have important implications during a multiyear drought may exist, however, such as crop rotations, which are discussed next.

## 2.2 Crop rotations and inter-year dynamics

A wide variety of crops can be grown in the study area, including onions, sugar beets, winter wheat, corn, alfalfa, and potatoes. Crop rotations are therefore diverse and flexible. Rather than adhering to a rigid crop rotation, producers in the study area have a suite of eligible crops from which to choose each year. The suite of eligible crops for a particular field depends on the field's crop history, and a set of agronomic 'rules' that producers follow to reduce pest and disease outbreaks. Example agronomic 'rules' include the following: onions are typically grown only once every 6 years in each field; sugar beets once every 5 years; wheat is not grown in consecutive years, and corn is grown consecutively for no more than 2 years. Constrained by a set of eligible crops for each field in a given year, the producer chooses one crop per field, taking into consideration relative profitability, probabilistic information about the upcoming growing season's water supply, and their goal to maximize the farm's discounted stream of expected returns. These crop decisions are made each year.

Agronomic rules (as opposed to rigid crop rotations) enable the producer to flexibly adjust crop plans after the water supply is revealed; however, they also generate inter-year dynamics. Crop choice for an individual field in a given year restricts the set of feasible crops in subsequent years. This restricted set of feasible crops might, in turn, reduce the producer's future drought-preparedness and response options. Inter-year dynamics arising from agronomic rules therefore create the need for a dynamic multiyear model, as well as the potential for more complex drought management decisions and impacts.

## 2.3 Water supply uncertainty and intra-year dynamics

Water supplies in a given year are finite, so the producer must carefully consider crop water requirements and drought tolerances when making their crop, irrigation technology, and deficit irrigation decisions. Furthermore, the

producer's water allotment for the upcoming growing season is uncertain at the time most crop-irrigation combinations must be chosen (in fall, winter, and early spring, i.e. stage 1). After the water allotment is revealed in mid-spring<sup>1</sup> (i.e. stage 2), the producer can respond by planting or abandoning fields that were prepared in stage 1, and deficit irrigating.

Division of the crop year into two decision stages, because of water supply uncertainty, creates intra-year dynamics between stages 1 and 2. The number of fields prepared for sugar beets in stage 1, for example, creates an upper bound on the number of fields that can be planted to sugar beets in stage 2. Additional sugar beet fields cannot be prepared after the water supply is revealed because of labour and machinery constraints (which are captured implicitly through agronomic rules, rather than explicitly). Winter wheat, as a second example, is both prepared and planted in stage 1; therefore, the number of fields planted to winter wheat in stage 1 creates an upper bound on the number of fields of winter wheat harvested in stage 2. Similar intra-year dynamics exist for nearly all other crops, with the exception of corn, which is both prepared and planted in stage 2.

## 2.4 Decision problem

The producer faces a stochastic and dynamic decision problem. They must choose the current year's crop plan, and make initial resource investments in it, before the growing season's water allotment is known (stage 1), and revise that plan in response to the revealed water allotment (stage 2). In doing so, the producer must consider the implication of stage 1 decisions for stage 2 activities (because of intra-year dynamics arising from water supply uncertainty), and stage 2 activities for future crop years (because of inter-year dynamics arising from agronomic rules). The producer's decision problem is modelled empirically as a multiyear discrete stochastic program, as described next (see Appendix S1 for the theoretical model; all supplementary appendices are available at <http://agecon.lib.umn.edu/>).

## 3. Empirical model

### 3.1 Primer on DSP

Discrete stochastic programming (DSP) is a method for solving decision problems that have random variables in the objective function and/or constraints (Cocks 1968). DSP is also known as discrete sequential stochastic programming or stochastic programming with recourse, but should not be

---

<sup>1</sup> The District allocates water using a shares system, so each producer receives the same volume of water per hectare. Water shortages are therefore shared equally per hectare. The District manager's announcement of the upcoming growing season's water allotment is sometimes revised as spring progresses and snowmelt is fully realized. We assume for simplicity that the allotment is announced with certainty each spring, just before the planting season.

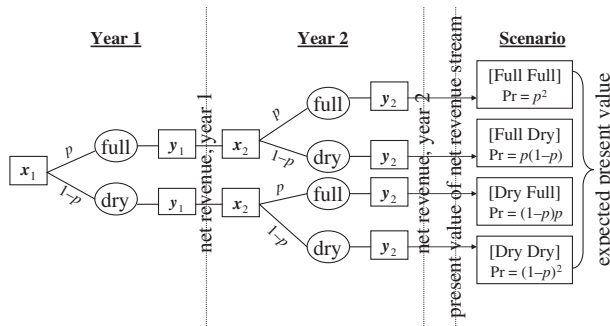

**Figure 1** Decision tree representation of a 2 year discrete stochastic program. Fall and spring crop activities,  $x_t$  and  $y_t$ , respectively, are chosen for  $t = 1, 2$  to maximize expected net present value of activities over the planning horizon, given uncertain water supplies. Once  $x_1$  is implemented; water supply for crop year 1 is revealed (full or dry), after which the corresponding  $y_1$  is implemented, resulting in returns to land and management for crop year 1.  $x_2$  is implemented in the fall of crop year 2. The water supply for crop year 2 is then revealed and the corresponding  $y_2$  is implemented, resulting in returns for crop year 2. At the time  $x_1$  is chosen, the producer does not know which of the four possible water supply scenarios will occur, and therefore faces a stochastic and dynamic decision problem.

confused with stochastic dynamic programming or Monte Carlo simulation (see Appendix S2 for a comparison of these approaches).

The structure of a DSP model (Figure 1) captures the sequential timing of decisions versus information discovery (Hardaker *et al.* 1997, p. 198). DSP can therefore model a multistage problem in which decisions are made both before and after random variables are realized; these decisions are known as first and second-stage (or recourse) decisions, respectively. DSP models can be expanded to accommodate any number of decision stages and a variety of information structures (Rae 1971; Apland and Hauer 1993). Those constructed such that first-stage decisions constrain activities in subsequent stages represent a stochastic and dynamic decision environment.

The optimal solution to a two-stage DSP problem includes a single set of first-stage activity levels, and one set of second-stage activity levels for each possible realization of the random variable. The solution therefore indicates not only how best to prepare for an uncertain future, but also how best to respond after some, but not necessarily all, uncertainty is resolved.

### 3.2 Case-study using DSP

#### 3.2.1 Model overview

The empirical DSP model is written and solved in General Algebraic Modelling System (GAMS; GAMS Development Corporation 2006). The producer maximizes the expected net present value of returns to land and management by choosing crop activities in stages 1 and 2 of each crop year of a 6 year planning horizon. A 6 year horizon captures the longest timeframe spanned

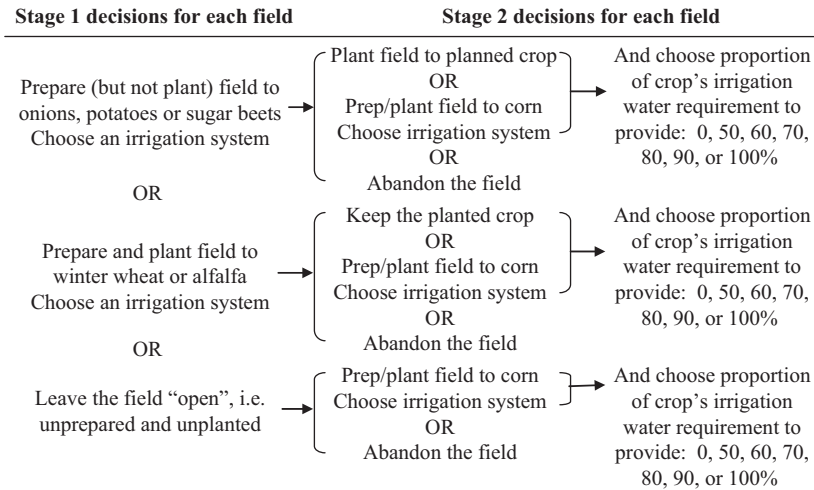

**Figure 2** Stage 1 and 2 decisions for each field in each year.

by an agronomic rule in the study area.<sup>2</sup> Stage 1 decisions (those made before the current year's water allotment is revealed) and stage 2 decisions (those made after the water allotment is revealed) are depicted in Figure 2.<sup>3</sup> Crop activities in stage 1 of any given year are constrained by crop activities in previous years. Costs incurred while preparing a field during stage 1 cannot be recouped if the field is abandoned in stage 2. Crop activities in stage 2 of any given year are constrained by crop activities in stage 1 of that year, as well as activities in previous years.

Water supply, a random variable, influences the objective function through crop yields (see Section 3.2.3). A crop year's water supply is revealed with certainty only after stage 1 decisions are made. In response to the revealed water supply, the producer revises their crop plan, and chooses deficit irrigation levels. Water use may not exceed the revealed supply, as supplemental water sources, including water trading, are uncommon in the District. The producer's deficit irrigation decisions determine crop yields, which directly influence the objective function.

### 3.2.2 Agronomic constraints

To represent agronomic 'rules' accurately as constraints, each field's crop history is tracked through time. This requires decision variables to be defined over discrete fields, rather than continuous hectares. Ten fields of identical quality

<sup>2</sup> Specifically, onions can only be planted once in a 6 year period; the producer's decision about onions in year  $t$  therefore imposes constraints on the feasible crop set through year  $t + 5$ . A 6 year planning horizon is sufficiently long to capture this particular source of inter-year dynamics, as well as all other agronomic rules that span shorter periods.

<sup>3</sup> No harvesting or marketing management options are included in the model, which implies that all crops planted in stage 2 are harvested and marketed under certainty. Price risk and post-planting risks, such as hail or freeze, are not modelled.

and size (86.5 hectares, or 35 acres, based on aerial photographs of the study area) are assumed. In any given decision period, the producer chooses one crop to plant in each field. For each field, a crop is therefore assigned either a value of 0 (if not chosen for that particular field) or 1 (if chosen). This contrasts to modelling crop choice as a continuous variable, in which the producer chooses the number of hectares of each crop, with no indication of the field(s) in which they will be located. Modelling crop choice as a discrete decision for individual fields allows crop history to be tracked at the field-level, rather than the farm-level; agronomic rules are captured more realistically as a result (as demonstrated in Appendix S3). One drawback of discrete decision variables is that the model becomes a stochastic integer program, which is difficult to solve because of the absence of convenient convexity properties (Schultz 2003).

The set of eligible crops for each field in a given year is a function of that field's crop history; therefore, crop choices in the previous planning horizon affect initial opportunities in the current planning horizon. The model accommodates an exogenously-defined crop history for the preceding planning horizon.<sup>4</sup> A crop history that imposes no constraints on the current planning horizon is assumed. This generates the largest set of eligible crops, the most flexibility in current crop decisions, and hence more conservative drought impact estimates.

Similarly, cropping activities in the current planning horizon affect opportunities in subsequent planning horizons. A terminal value function is therefore defined to relate cropping activities in the current planning horizon to land rental values in the subsequent planning horizon. More specifically, if a parcel of land is capable of supporting high-value crops during the next planning horizon (because of activities in the current planning horizon), the producer receives a relatively large rental payment to reflect their ability to lease that parcel for a premium. The producer otherwise receives a small rental payment because their parcel can only support low-value crops.

### 3.2.3 Crop yields

Deficit irrigation, i.e. the practice of intentionally providing less water than is needed to maximize crop yield, is assumed to influence yields through the following yield response function (developed by Doorenbos and Kassam 1979; tested by Food and Agriculture Organization of the United Nations 2002):

$$\text{yield}_{\text{actual}} = \text{yield}_{\text{max}} * [1 - [k * [1 - [(w * (ET_{\text{max}} - \text{Precip}) + \text{Precip}) / ET_{\text{max}}]]]]].$$

Water is the only input assumed to limit crop yield. The degree to which realized crop yield ( $\text{yield}_{\text{actual}}$ ) deviates from maximum yield ( $\text{yield}_{\text{max}}$ ) depends on the crop's sensitivity to water stress ( $k$ ), precipitation received

---

<sup>4</sup> Crop history in the preceding planning horizon is defined exogenously, rather than determined endogenously, because of limits in GAMS on the number of subscripts on decision variables.



during the growing season (Precip), which is assumed constant and certain at 10.2 cm, and the proportion ( $w$ ) provided of the crop's maximum irrigation water requirement ( $ET_{\max}$ ).

This function assumes water deficits occur in equal proportions throughout the growing season, i.e. season-long deficit irrigation. Strategic deficit irrigation, in which crops are deficit-irrigated during their least sensitive growth stages, is preferable; however, data for the study area are insufficient to apply it. Yield estimates under season-long deficit irrigation likely underestimate yields under strategic-deficit irrigation, and therefore underestimate the use of deficit irrigation in the study area.

#### 3.2.4 *Irrigation technology*

Available irrigation technologies include furrow, reuse furrow, solid set sprinkler, wheel line sprinkler, centre pivot sprinkler, and subsurface drip. Feasibility varies by crop (e.g. corn is too tall for wheel line sprinklers); Appendix S4 reports parameter values for feasible crop-irrigation combinations.

Simplifying assumptions about irrigation technology adoption are made because of the decision model's inherent complexity. An irrigation technology is chosen in stage 1 for each field (except those left unprepared), and cannot be changed in stage 2. Irrigation technology in a given field can, however, be changed between years. This simplifying assumption implies that the producer is either able to use the irrigation system on another field (technological advances have made some drip, sprinkler and reuse furrow systems portable), sell it for the balance of the principal, or idle it at no opportunity cost. A variety of irrigation systems used in the study area can be easily moved or idled, however. It would therefore be overly-restrictive to impose a single irrigation system on individual fields for the entire planning horizon. Our simplified treatment of irrigation technology adoption overestimates the producer's year-to-year flexibility, and therefore reduces the model's drought impact estimates.

#### 3.2.5 *Water allotments*

A producer's annual water allotment is, in reality, a continuous random variable, and therefore best represented by a probability density function. Unfortunately, the decision problem becomes unreasonably difficult to solve when water is defined as a continuous variable, because of the large number of decision variables and stages in the model (Birge and Louveaux 1997, p. 91). A discrete probability distribution is therefore used to approximate the water allotment's density function. Nonetheless, dimensionality increases quickly with the number of water allotment categories (i.e. states of nature). Two states of nature, in each year of a 6 year planning horizon, for example, generates 64 unique water supply scenarios. Three states of nature, in contrast, generates 729 unique water supply scenarios, and four states of nature generates 4096 unique scenarios. A Gaussian quadrature procedure (Miller and Rice 1983; Preckel and Devuyst 1992) is used to help identify a small but meaningful number of water allotment categories for the District.

**Table 1** Water allotments for the Vale Oregon Irrigation District, 1981–2003

Year	Allotment (m <sup>3</sup> /ha)	Year	Allotment (m <sup>3</sup> /ha)
1981	10,922	1993	9398
1982	10,922	1994	7874
1983	11,176	1995	8382
1984	10,922	1996	9144
1985	10,668	1997	10,922
1986	10,922	1998	8382
1987	8890	1999	9144
1988	3048	2000	9652
1989	8890	2001	6604
1990	6350	2002	6604
1991	3302	2003	5334
1992	2794		

Producers in the study area indicate they can fully irrigate planned crops if given 9144–10,668 m<sup>3</sup>/ha (36–42 acre-inches per acre), and that economically significant water shortages begin to occur around 6096–7620 m<sup>3</sup>/ha (24–30 acre-inches per acre). Application of the Gaussian quadrature procedure to historical water allotment data (Table 1), assuming two states of nature, suggests similar water allotments of 4064 and 10,160 m<sup>3</sup>/ha (16 and 40 acre-inches per acre) with probabilities of 40 per cent and 60 per cent, respectively. These sources of information led us to select the following two water allotment categories and associated probabilities: ‘Dry’, defined as 6096 m<sup>3</sup>/ha (24 acre-inches per acre) with a 40 per cent probability in any given year, and ‘Full’, defined as 10,160 m<sup>3</sup>/ha (40 acre-inches per acre) with a 60 per cent probability in any given year. Appendix S5 explores the use of two versus three water allotment categories.

Historical streamflow data above reservoirs in the study area shows no correlation between years, so statistical independence between annual water allotments is assumed. The probability of a particular 6 year water supply outcome (e.g. Dry Dry Full Full Full Dry) is therefore calculated as the product of the probabilities associated with each year’s allotment (e.g.  $\text{pr}(\text{Dry Dry Full Full Full Dry}) = \text{pr}(\text{Dry}) * \text{pr}(\text{Dry}) * \text{pr}(\text{Full}) * \text{pr}(\text{Full}) * \text{pr}(\text{Full}) * \text{pr}(\text{Full})$ ).

### 3.2.6 Model output

The model’s optimal solution<sup>5</sup> includes a crop plan for each of the 64 water supply scenarios. Each crop plan includes optimal stage 1 and 2 activities for

<sup>5</sup> The model is solved using CPLEX, a commercially available solution algorithm (ILOG Inc. 2006). Because of the size and complexity of the model, CPLEX reports a solution that approximates the global optimal solution to within a specified tolerance level. Although a zero tolerance level can be set (i.e. no difference is allowed between the approximate and global solutions’ objective function values), this increases the solve time beyond reasonable limits. The approximate solutions presented here (referred to, hereafter, as optimal) are within 2.5 per cent of the global optimal solution’s objective function value.

each year of the 6 year planning horizon. All 64 crop plans are solved for simultaneously, which enables DSP to mimic forward-looking behaviour, rather than naïve or recursive behaviour. Each water supply scenario's associated crop plan generates a net present value of returns to land and management (assuming a 5 per cent discount rate, and a 7 per cent interest rate (American Agricultural Economics Association Task Force 1998)). Given the probability and net present value of returns associated with each water supply scenario, the producer's expected net present value of returns (i.e. objective function value) is calculated. Optimal crop plans and associated returns for various water supply scenarios are then compared to address the research questions.

## 4. Results and discussion

### 4.1 Is a multiyear drought's impact more than the sum of its parts?

A multiyear drought is comprised of individual years of drought whose economic impacts may not necessarily be independent, particularly for farm systems with inter-year dynamics. If the economic impacts of individual years of drought are interdependent, it may be incorrect to examine an individual year of drought independent of events and decisions in preceding and subsequent years. The following four scenarios' crop plans and associated returns are compared to determine if the economic impact of a 2 year drought (occurring in years 2 and 3 of a 6-year planning horizon) can be deconstructed into independent parts, or is more than the sum of its component years' impacts: (A) [Full Dry Full Full Full Full], (B) [Full Full Full Full Full Full], (C) [Full Full Dry Full Full Full], and (D) [Full Dry Dry Full Full Full]. Scenario (A) represents a single-year drought in year 2. Scenario (B) represents the case of no years of drought, and serves as a baseline to which the other scenarios' crop plans and returns are compared. Scenario (C) represents a single-year drought in year 3. Scenario (D) represents a 2 year drought in years 2 and 3.

A comparison of scenarios (A) and (B) reveals that a single-year drought in year 2 generates a total loss of returns over the 6 year planning horizon of \$30,040 (4 per cent of total undiscounted returns) (Table 2, row-i). A similar comparison of scenarios (C) and (B) shows that a single-year drought in year 3 generates a total loss of \$22,424 (3 per cent of total undiscounted returns) (Table 2, row-ii). If the impacts of these single-year events are in fact independent (i.e. confined within the years in which the droughts occurred), the following two outcomes are expected: (i) the economic impact of a 2 year drought that occurs in years 2 and 3 should approximately equal the sum of the individual droughts' impacts (\$52,464 or 6 per cent), and (ii) losses attributable to a year 3 drought should be the same regardless of whether it is preceded by drought or not.

Comparison of scenarios (D) and (B) reveals that a 2 year drought that occurs in years 2 and 3 generates a total loss of \$85,737 (10 per cent of total

**Table 2** Impact of various drought events on undiscounted returns to land and management in each year of the planning horizon

Drought event: scenarios compared†	Change in undiscounted returns by year of the planning horizon‡ (% change\$)							Total
	Yr1	Yr2	Yr3	Yr4	Yr5	Yr6	Terminal	
(i) Drought in year 2, no previous drought: (A), (B)	\$0 (0)	-\$25,641 (-49)	\$2547 (+8)	\$2725 (+8)	\$3061 (+15)	-\$2710 (-11)	-\$10,023 (-2)	-\$30,040 (-4)
(ii) Drought in year 3, no previous drought: (C), (B)	\$0 (0)	\$0 (0)	-\$23,361 (-77)	-\$7191 (-22)	\$12,530 (+63)	\$3080 (+12)	-\$7482 (-1)	-\$22,424 (-3)
(iii) Drought in years 2 & 3: (D), (B)	\$0 (0)	-\$25,641 (-49)	-\$32,271 (-107)	-\$5697 (-18)	\$10,216 (+51)	-\$3738 (-15)	-\$28,607 (-5)	-\$85,737 (-10)
(iv) Drought in year 3, prior drought in year 2:¶ (D), (A)	\$0 (0)	\$0 (0)	-\$34,818 (-106)	-\$8422 (-24)	\$7155 (+31)	-\$1028 (-4)	-\$15,986 (-3)	-\$55,697 (-7)

†Scenario Key: (A) = [Full Dry Full Full Full], (B) = [Full Full Full Full Full Full], (C) = [Full Full Dry Full Full Full], (D) = [Full Dry Dry Full Full Full Full].

‡Change in undiscounted returns to land and management is calculated in Yr# for scenarios (v), (z) as: net rev in Yr# for (y) - net rev in Yr# for (z).

\$% change in Yr# is calculated as net rev in Yr# for (y) - net rev in Yr# for (z)/net rev in Yr# for (z) \* 100%.

¶This comparison isolates the marginal impact of Yr3 from the total impact of a 2 year drought occurring in Yrs 2 and 3. Row (ii), in contrast, calculates the total impact of a 1 year drought that occurs in Yr3, while row (iii) calculates the total impact of a 2 year drought that occurs in Yrs 2 and 3.

undiscounted returns) (Table 2, row-iii), which is 63 per cent more than the hypothesized loss of \$52,464. The economic impact of this multiyear drought is indeed more than the sum of its parts. This result is also found in a comparison of the impact of a year 3 drought that is preceded by a year 2 drought versus a year 3 drought that is not. The marginal impact of a year 3 drought when preceded by a year 2 drought (obtained by comparing scenarios (D) and (A); see Table 2, row-iv) is \$55,697 (7 per cent), as compared to \$22,424 (3 per cent) when not preceded by drought (Table 2, row-ii). That is, the marginal impact of a year 3 drought is 150 per cent larger when preceded by drought in year 2. The underlying explanation of this result is discussed in the next subsection.

Similar results are found for other multiyear drought scenarios (see Appendix S6), including a 2 year drought that occurs in years 2 and 4, i.e. scenario [Full Dry Full Dry Full Full]. In this case, a single-year drought in year 2 generates a total loss over the 6 year planning horizon of \$30,040 (4 per cent of total undiscounted returns). A single-year drought in year 4 generates a total loss of \$17,198 (2 per cent). If the economic impacts of the two events were independent, the 2 year drought's impact should approximately equal the sum of the individual years' impacts (\$47,238 or 5.8 per cent). Instead, the 2 year drought generates a total loss of \$72,336 (8.8 per cent). It may be tempting to analyse this particular drought scenario as two independent years of drought, because a wet year separates them. It is clear, however, that the economic impacts of the non-consecutive years of drought are interdependent; the impact of drought in year 4 is conditional on the impact of drought in year 2. Therefore, even the total impact of non-consecutive years of drought cannot necessarily be estimated as the sum of two independent events.

#### **4.2 Can response to one drought increase vulnerability to subsequent droughts?**

For the drought scenario [Full Dry Dry Full Full Full], the impact of a year 3 drought is larger when preceded by a year 2 drought. This is because the producer attempts to recover from the year 2 drought (which caused them to abandon two fields of sugar beets) by preparing four fields for sugar beets in the fall of year 3, rather than three (Figure 3). When drought is revealed in the spring of year 3, the producer's best strategy is to abandon three fields. Had they attempted only three fields in year 3, losses associated with the year 3 drought would be smaller because only two fields would have to be abandoned (Figure 4). It was optimal under uncertainty, however, to attempt in year 3 to recover revenue lost during the year 2 drought, despite the possibility of incurring more severe drought impacts in the event of a dry year 3. Under certainty, a producer would know not to attempt in year 3 to recover revenue lost during the year 2 drought; losses during the year 3 drought would be smaller as a result.

The same explanation exists for the drought scenario [Full Dry Full Dry Full Full]. The producer attempts four fields of sugar beets in year 4, rather

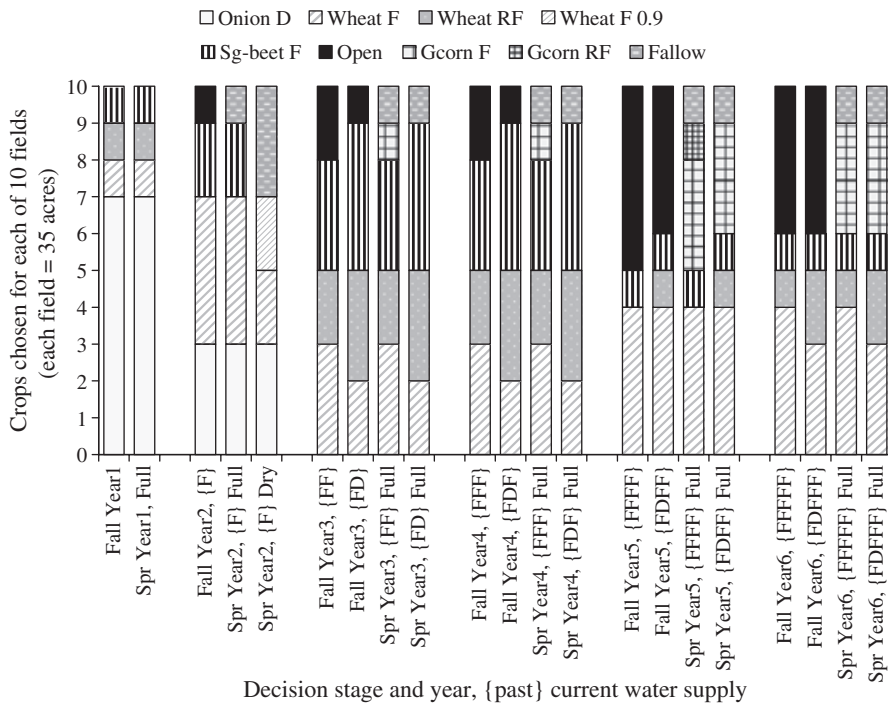
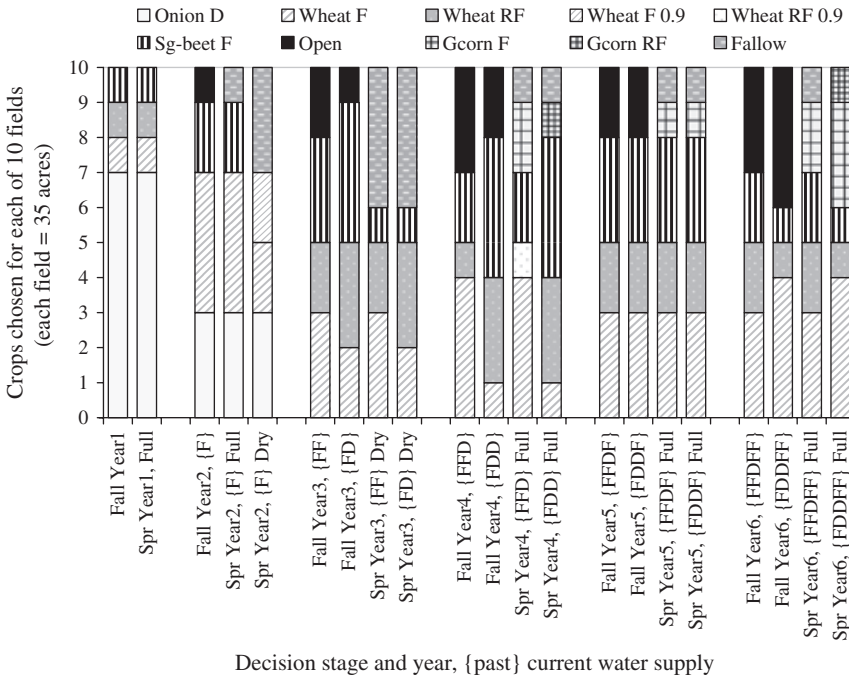

**Figure 3** Crop impacts of a year 2 drought. A stage-by-stage comparison of optimal crop activities for scenarios [Full Full Full Full Full Full] and [Full Dry Full Full Full Full]. Crop Key: F, furrow; RF, reuse furrow; D, drip; 0.9, 90 per cent of crop’s irrigation requirement is provided.

than three, to take advantage of a potential opportunity to grow sugar beets in one of the fields abandoned in year 2 (rather than waiting 5 years, as would be required if they adhered to a fixed crop plan). In response to drought in year 4, the producer must abandon three fields rather than two, and therefore experiences larger losses to the year 4 drought than they would if the year 2 drought had not occurred.

The above results demonstrate that a producer’s decisions in response to a particular year of drought can affect their future circumstances and hence the losses incurred during subsequent years of drought, particularly in the presence of uncertainty and inter-year dynamics. This result echoes the sentiment of producers in the study area who indicate that changes in their crop plan in response to drought often affects cropping activities for years to come, and hence the impact of future droughts.

One can imagine similar results arising for other farm systems that exhibit inter-year dynamics. A tree-fruit producer, for example, might lose more trees during a year of drought (or a year of abnormal disease outbreaks) than would be expected during a normal year. The optimal response might be to plant more replacement trees than usual, because of their time preference and the delay before new trees will bear fruit. If



**Figure 4** Crop impacts of a year 3 drought when preceded by a full versus dry year 2. A stage-by-stage comparison of activities for scenarios [Full Full Dry Full Full Full] and [Full Dry Dry Full Full Full]. Crop Key: F, furrow; RF, reuse furrow; D, drip; 0.9, 90 per cent of crop’s irrigation requirement is provided.

drought occurs in the following year, however, the producer risks the loss of a larger number of young trees than usual, or alternatively, the loss of a larger number of older trees than usual if they direct scarce water supplies towards young trees.

Similarly, a cow-calf producer might begin feeding hay earlier in the winter than usual in response to drought (and associated shortages in range forage). Whether the producer purchases additional hay, or draws down their own hay reserves, they are left with fewer resources than usual, and are consequently more vulnerable in the event of subsequent years of drought. The impact of a subsequent year of drought might be larger than usual because the previous year of drought depleted their physical or financial reserves.

This concept also applies to non-agricultural contexts, and other natural disasters. The U.S. Forest Service, for example, recently discovered that an aerial retardant used to extinguish wildfires promotes the spread of invasive species, some of which create new fire hazards (e.g. cheatgrass). Use of the retardant in response to a wildfire therefore increases the probability of future wildfires in the area. The agency must determine whether the immediate benefits of using the retardant to extinguish an existing wildfire outweigh the potential future costs of subsequent wildfires. Similarly, Hurricane Katrina

changed the city of New Orleans' vulnerability to subsequent hurricanes. Because Katrina damaged levees and coastal wetlands, subsequent hurricanes may be more likely to cause flooding and generate damages.

## 5. Conclusions

Producers whose farm systems exhibit inter-year dynamics weigh the immediate benefits of a particular drought response against potential future costs in the event of subsequent droughts. Even when producers behave optimally, management decisions in response to drought can worsen the impacts of subsequent years of drought. The marginal economic impact of a given year of drought was shown to increase by as much as 150 per cent when preceded by previous years of drought. This highlights the importance of evaluating the impacts of an individual year of drought in the context of preceding and subsequent years. It also confirms Clawson *et al.*'s (1980) hypothesis, and producers' assertion, that the form of recovery from one drought might affect a producer's ability to cope with subsequent droughts.

Inter-year dynamics and uncertainty about a drought's duration make it more difficult for producers to determine how best to respond to a particular year of drought. Economists can assist producers by (i) being cognizant of the increased complexity of drought preparedness and response decisions when inter-year dynamics and the potential for multiyear drought exist, and (ii) developing multiyear stochastic and dynamic simulation models that can be used in consultation with producers to explore the intra- and inter-year consequences of alternative responses to drought under various water supply scenarios.

Similarly, farm policymakers and administrators need to understand that a year of drought can change a producer's crop plan for years to come, thereby generating impacts long after the drought itself subsides, and potentially exacerbating the impact of drought in subsequent years. They also need to interpret drought impact estimates carefully, particularly if derived in a manner that disregards water supply conditions in preceding years, and consider the ability of alternative risk management tools to reduce producers' vulnerability during future drought events.

Disaster assistance and crop insurance (including prevented planting provisions), for example, provide payments based on the current year's crop activities, and therefore inherently account for the influence of past droughts on the current drought's impact. They do not, however, necessarily reduce producers' vulnerability to future droughts. Producers might still attempt to recover lost revenue opportunities during what is revealed to be another year of drought. Water supply forecasts with longer lead-times, in contrast, would help producers avoid failed recovery attempts, and thereby reduce vulnerability to future droughts. The value of forecasts with longer lead-time is relatively well-studied (e.g. Carberry *et al.* 2000), so an estimate using this study's multiyear stochastic framework is left for future investigation.



### Supporting Information

Additional Supporting Information may be found in the online version of this article:

**Appendix S1.** Theoretical decision model.

**Appendix S2.** Discrete stochastic programming versus simulation and stochastic dynamic programming.

**Appendix S3.** Continuous versus discrete crop choice variables.

**Appendix S4.** Parameter values assumed for various crop-irrigation technology combinations.

**Appendix S5.** Consideration of three states of nature.

**Appendix S6.** Profit impact of alternative multiyear drought scenarios.

Please note: Wiley-Blackwell is not responsible for the content or functionality of any supporting materials supplied by the authors. Any queries (other than missing material) should be directed to the corresponding author for the article.

### References

- American Agricultural Economics Association Task Force (1998). Conceptual issues in cost and return estimates, in Eidman, V. (ed.), *Commodity Costs and Returns Estimation Handbook*. American Agricultural Economics Association, Ames, IA, pp. 1–84.
- Apland, J. and Hauer, G. (1993). Discrete stochastic programming: concepts, examples and a review of empirical applications, Staff Paper P93-21, University of Minnesota, St. Paul, MN.
- Bernardo, D.J., Whittlesey, N.K., Saxton, K.E. and Bassett, D.L. (1987). An irrigation model for management of limited water supplies, *Western Journal of Agricultural Economics* 12, 164–173.
- Birge, J.R. and Louveaux, F. (1997). *Introduction to Stochastic Programming*. Springer-Verlag New York, Inc., New York.
- Bryant, K.J., Mjelde, J.W. and Lacewell, R.D. (1993). An intraseasonal dynamic optimization model to allocate irrigation water between crops, *American Journal of Agricultural Economics* 75, 1021–1029.
- Carberry, P., Hammer, G., Meinke, H. and Bange, M. (2000). The potential value of seasonal climate forecasting in managing cropping systems, in Hammer, G.L., Nicholls, N. and Mitchell, C. (eds.), *Applications of Seasonal Climate Forecasting in Agricultural and Natural Ecosystems*. Kluwer Academic Publishers, Boston, pp. 167–181.
- Chen, C., McCarl, B.A. and Adams, R.M. (2001). Economic implications of potential ENSO frequency and strength shifts, *Climatic Change* 49, 147–159.
- Chen, C., McCarl, B.A. and Williams, R.L. (2006). Elevation dependent management of the Edwards Aquifer: linked mathematical and dynamic programming approach, *Journal of Water Resources Planning & Management* 132, 330–340.
- Clawson, M., Ottoson, H.W., Duncan, M. and Sharp, E.S. (1980). Task group on economics, in Rosenberg, N.J., Hoffman, R.O., Quinn, M.L. and Wilhite, D.A. (eds.), *Drought in the Great Plains: Research on Impacts and Strategies*. BookCrafters, Inc., Chelsea, MI, pp. 43–59.
- Cocks, K.D. (1968). Discrete stochastic programming, *Management Science* 15, 72–79.
- CPLEX (2006). *Computer Program*. ILOG Inc., Sunnyvale, CA.
- Dai, A., Trenberth, K.E. and Qian, T. (2004). A global dataset of Palmer Drought Severity Index for 1870–2002: relationship with soil moisture and effects of surface warming, *Journal of Hydrometeorology* 5, 1117–1130.

- Diaz, H.F. (1983). Drought in the United States: some aspects of major dry and wet periods in the contiguous United States, 1895–1981, *Journal of Climate and Applied Meteorology* 22, 3–16.
- Doorenbos, J. and Kassam, A.H. (1979). *Yield Response to Water*. Food and Agriculture Organization of the United Nations, Rome.
- Dudley, N.J. (1988). A single decision-maker approach to irrigation reservoir and farm management decision making, *Water Resources Research* 24, 633–640.
- Food and Agriculture Organization of the United Nations (2002). *Deficit Irrigation Practices*. Water Reports No. 22, Food and Agriculture Organization of the United Nations, Rome.
- General Algebraic Modeling System (2006). *Computer Program*. GAMS Development Corporation, Washington, DC.
- Gleick, P.H. (2000). Water: the potential consequences of climate variability and change for the water resources of the United States, Pacific Institute for Studies in Development, Environment, and Security, Oakland.
- Hardaker, J.B., Huirne, R.B.M. and Anderson, J.R. (1997). *Coping with Risk in Agriculture*. CABI Publishing, New York.
- Iglesias, E., Garrido, A. and Gómez-Ramos, A. (2003). Evaluation of drought management in irrigated areas, *Agricultural Economics* 29, 211–229.
- Iglesias, E., Garrido, A. and Gómez-Ramos, A. (2007). Economic drought management index to evaluate water institutions' performance under uncertainty, *Australian Journal of Agricultural and Resource Economics* 51, 17–38.
- Keplinger, K.O., McCarl, B.A., Chowdhury, M.E. and Lacewell, R.D. (1998). Economic and hydrologic implications of suspending irrigation in dry years, *Journal of Agricultural and Resource Economics* 23, 191–205.
- McKeon, G., Ash, A., Hall, W. and Stafford Smith, M. (2000). Simulation of grazing strategies for beef production in north-east Queensland, in Hammer, G.L., Nicholls, N. and Mitchell, C. (eds.), *Applications of Seasonal Climate Forecasting in Agricultural and Natural Ecosystems*. Kluwer Academic Publishers, Boston, pp. 227–252.
- Meehl, G.A., Stocker, T.F., Collins, W.D., Friedlingstein, P., Gaye, A.T., Gregory, J.M., Kitoh, A., Knutti, R., Murphy, J.M., Noda, A., Raper, S.C.B., Watterson, I.G., Weaver, A.J. and Zhao, Z.-C. (2007). Global climate projections, in Solomon, S., Qin, D., Manning, M., Chen, Z., Marquis, M., Averyt, K.B., Tignor, M. and Miller, H.L. (eds.), *Climate Change 2007: The Physical Science Basis*. Cambridge University Press, New York, pp. 747–845.
- Mejias, P., Varela-Ortega, C. and Flichman, G. (2004). Integrating agricultural policies and water policies under water supply and climate uncertainty, *Water Resources Research* 40, W07S03, doi: 10.1029/2003WR002877.
- Miller, A.C. and Rice, T.R. (1983). Discrete approximations of probability distributions, *Management Science* 29, 352–362.
- Nicholls, N. (2004). The changing nature of Australian droughts, *Climatic Change* 63, 323–336.
- Preckel, P.V. and Devuyt, E. (1992). Efficient handling of probability information for decision-analysis under risk, *American Journal of Agricultural Economics* 74, 655–662.
- Rae, A.N. (1971). An empirical application and evaluation of discrete stochastic programming in farm management, *American Journal of Agricultural Economics* 53, 625–638.
- Rosenzweig, C. and Hillel, D. (1993). The Dust Bowl of the 1930s-analog of greenhouse-effect in the Great-Plains, *Journal of Environmental Quality* 22, 9–22.
- Schultz, R. (2003). Stochastic programming with integer variables, *Mathematical Programming Series B* 97, 285–309.
- Thompson, D., Jackson, D., Tapp, N., Milham, N., Powell, R., Douglas, B., Kennedy, G., Jack, E. and White, G. (1996). Analysing drought strategies to enhance farm financial viability, Final Report, University of New England, Armidale, New South Wales, Australia.

- Toft, H.I. and O'Hanlon, P.W. (1979). A dynamic programming model for on-farm decision making in a drought, *Review of Marketing and Agricultural Economics* 47, 5–16.
- Weisensel, W.P., Van Kooten, G.C. and Schoney, R.A. (1991). Relative riskiness of fixed vs. flexible crop rotations in the dryland cropping region of western Canada, *Agribusiness* 7, 551–560.
- Wilhite, D.A., Diodato, D.M., Jacobs, K., Palmer, R., Raucher, B., Redmond, K., Sada, D., Helm-Smith, K., Warwick, J. and Wilhelmi, O. (2006). Managing drought: a roadmap for change in the United States, Paper presented at Managing drought and water scarcity in vulnerable environments: creating a roadmap for change in the United States; The Geological Society of America, 18–20 September, Longmont, CO.