



**AgEcon** SEARCH  
RESEARCH IN AGRICULTURAL & APPLIED ECONOMICS

*The World's Largest Open Access Agricultural & Applied Economics Digital Library*

**This document is discoverable and free to researchers across the globe due to the work of AgEcon Search.**

**Help ensure our sustainability.**

Give to AgEcon Search

AgEcon Search

<http://ageconsearch.umn.edu>

[aesearch@umn.edu](mailto:aesearch@umn.edu)

*Papers downloaded from **AgEcon Search** may be used for non-commercial purposes and personal study only. No other use, including posting to another Internet site, is permitted without permission from the copyright owner (not AgEcon Search), or as allowed under the provisions of Fair Use, U.S. Copyright Act, Title 17 U.S.C.*

*No endorsement of AgEcon Search or its fundraising activities by the author(s) of the following work or their employer(s) is intended or implied.*

TR-169 (1930)

USDA TECHNICAL BULLETINS

UPDATA

THE KILN DRYING OF SOUTHERN YELLOW PINE LUMBER

TEESDALE, L. V.

1 OF 1

# START

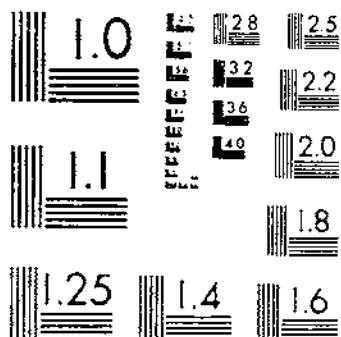

MICROCOPY RESOLUTION TEST CHART  
NATIONAL BUREAU OF STANDARDS 1963-A

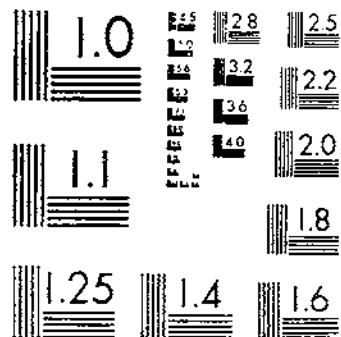

MICROCOPY RESOLUTION TEST CHART  
NATIONAL BUREAU OF STANDARDS 1963-A



UNITED STATES DEPARTMENT OF AGRICULTURE  
WASHINGTON, D. C.

THE KILN DRYING OF SOUTHERN  
YELLOW PINE LUMBER<sup>1</sup>

By L. V. TEESDALE

Senior Engineer, Forest Products Laboratory,<sup>2</sup> Branch of Research, Forest Service

CONTENTS

	Page		Page
Introduction.....	1	Experiments at commercial plants—Cont.	
Improving the utilization of our forest crop.....	1	Controlling kiln degrade.....	27
Available information on kiln drying.....	2	Types of kilns for seasoning southern yellow pine.....	28
Scope and object of the bulletin.....	2	Smoke and furnace-heated kilns.....	28
Fundamental principles of kiln drying southern yellow pine.....	3	Steam-heated kilns.....	20
Behavior of moisture in wood.....	3	Kiln operation.....	38
Temperature.....	4	Faults common in kiln operation.....	38
Humidity.....	7	Drying schedules.....	41
Circulation.....	7	Stock separation to hasten seasoning.....	45
Effect of shrinkage and of swelling.....	9	Moisture-content determination.....	46
Characteristics of southern yellow pine that affect kiln drying.....	14	Variation in moisture content throughout the kiln charge.....	48
Seasoning to suit markets.....	15	Effect of the drying schedule on the exudation of pitch.....	48
Survey of kiln-drying practice.....	18	Cost of shutting down the kiln.....	49
1921 survey.....	18	Steam consumption.....	50
1922 survey.....	18	Temperature-control devices.....	50
Extent of kiln-drying practice.....	15	Humidity-control devices.....	52
Drying conditions in the kilns.....	19	Recording thermometers.....	52
Moisture content of kiln-dried stock.....	20	Location of thermostats and thermostat bulbs.....	53
Extent of degrade caused by kiln drying.....	20	Handling stock before and after kiln drying.....	53
Conclusions drawn from survey.....	23	Piling on kiln cars.....	53
Experiments at commercial plants.....	23	Storage after kiln drying and before machining.....	58
Experiments on shortleaf pine.....	23	Machining kiln-dried stock.....	60
Experiments on longleaf pine.....	24	Protecting the finished product.....	62
Causes of degrade.....	25	Dry-kiln construction and maintenance.....	63
Defects that appear in kiln drying.....	25	Literature cited.....	66
Method of grading.....	26		
Loss caused by inferior kiln drying.....	27		

INTRODUCTION

IMPROVING THE UTILIZATION OF OUR FOREST CROP

The Forest Products Laboratory has for many years been engaged in studying ways and means of obtaining the best return from our

<sup>1</sup> The Forest Products Laboratory acknowledges the cooperation of the Southern Pine Association; the Lufkin Land & Lumber Co., of Lufkin, Tex.; the Central Coal & Coke Co., of Conroe, Tex.; and the Kaul Lumber Co., of Tuscaloosa, Ala., whose active participation in the survey, the practical tests, and the demonstrations carried out in the course of the investigation were of material assistance. The laboratory is also indebted to a number of other southern yellow pine manufacturers, who assisted in diverse ways during the surveys and the experiments reported in this bulletin. The writer acknowledges especially the work of A. C. Knauss, who as an engineer at the Forest Products Laboratory conducted the survey of 1922 and made the early experiments at commercial plants.

<sup>2</sup> Maintained by the United States Department of Agriculture at Madison, Wis., in cooperation with the University of Wisconsin.

forest land, especially through the reduction of waste in using the forest crop. The fullest utilization of this crop not only requires intelligent felling and logging methods in the forest but also requires that the highest yield be obtained from the log. In lumber manufacture this means the highest possible yield of lumber, both in quality and quantity. The utilization of low-grade lumber is one of the key problems in the practice of forestry; the demand is for high-grade material. If poor seasoning reduces the grade of lumber, then more trees must be cut to supply the demand; hence a needless drain, since poor seasoning is usually preventable.

Improvement in seasoning practice will increase the net forest yield through reduction of waste; it will help to retain the potential value of the crop through reduction of seasoning defects. Further, although the inherent properties of a piece of wood are determined initially by the species and growth conditions of the tree, these properties can be modified through proper seasoning treatment, and lumber can thus be made more suitable for its ultimate use requirements. Hence improvement in seasoning for suitability, in addition to improvement in seasoning to decrease actual waste, will again make for better utilization of our forest crop.

#### AVAILABLE INFORMATION ON KILN DRYING

A large amount of information on the kiln drying of lumber is available (1, 3, 4, 5, 6, 7, 8, 9, 10, 11).<sup>3 4</sup> Some of it, however, is too general in character to meet specific needs fully. The southern yellow pines, like many other species, have certain problems peculiar to themselves, making a definite and detailed treatment of those problems desirable for best results in kiln drying.

Until quite recently it was assumed in the trade that the degrade resulting from the kiln drying of southern yellow pine was very low. However, a survey of seasoning practice and degrade made by the Southern Pine Association in 1921 and a similar survey made by the Forest Products Laboratory in cooperation with the Southern Pine Association in 1922 brought out the fact that the actual drying losses were much greater than had been supposed, and the opportunity for improvement then became obvious. It was estimated in 1922 that the annual loss from kiln-drying degrade suffered by the southern yellow pine industry approached \$10,000,000. The practical seasoning experiments that were initiated after the two surveys had been completed demonstrated that the adoption of the best kiln-drying practice for the seasoning of southern yellow pine was technically and economically sound.

#### SCOPE AND OBJECT OF THE BULLETIN

The purpose of this bulletin is to present briefly the general principles of kiln drying and then to show the application of these principles to the kiln drying of southern yellow pine lumber. Specifi-

<sup>3</sup> Italic numbers in parentheses refer to "Literature cited," p. 66.

<sup>4</sup> The *Kiln Drying Handbook* (5) presents a full discussion of the general subject of kiln drying. It contains descriptions, more detailed than those offered here, of such matters as the technic of moisture-determination and of moisture-distribution tests, following daily drying rates by means of samples of known initial moisture content, determining humidity in the kiln, and the construction and operation of various kinds of kiln equipment.

cally, it is intended to show (1) how to control drying conditions in the kiln, (2) the proper method of handling stock before and after kiln drying, and (3) how observance of proper kiln operation and handling methods is economically advantageous.

## FUNDAMENTAL PRINCIPLES OF KILN DRYING SOUTHERN YELLOW PINE

### BEHAVIOR OF MOISTURE IN WOOD

#### MOISTURE IN THE WOOD

The seasoning of lumber may be considered chiefly as the removal of the excess moisture in the wood, thereby making the material more suited for its ultimate use. In the standing tree the moisture, which is commonly called sap, serves to distribute food and thus assists growth, but after the tree has been cut the moisture is superfluous. In commercial seasoning, however, some moisture is left in the wood, although most of it is removed.

#### TRANSFUSION OF MOISTURE

Moisture is held in wood in two ways: (1) As free water in the openings or cell cavities and (2) as imbibed water in the cell walls. When drying commences the moisture dries out of the cell cavity first and then dries from the cell wall. All moisture removed, of course, is carried away from the exposed surfaces; the moisture moves from parts of high to parts of low moisture content somewhat as a fluid travels along a wick. The structure of wood results in resistance to the flow of moisture; this resistance varies widely among different species. Southern yellow pine does not offer so much resistance to the movement of moisture as many of the other softwoods do, a point that simplifies its seasoning problem very materially. At the same time the resistance to the passage of moisture has an important bearing on shrinkage, and shrinkage causes most of the difficulty encountered in seasoning, whether it is in pine or in other species.

#### FIBER-SATURATION POINT AND SHRINKAGE

As green wood dries, the cell cavities become empty first and when they are entirely empty the cell walls start to dry. As long as there is any water in a cell cavity that cell will not shrink, but shrinkage does begin as soon as the water commences to leave the cell walls. The stage when the cell cavity is empty and the cell walls are still saturated is called the "fiber-saturation point." Since drying commences at the surface, the outer part of the wood attempts to shrink first but the more moist inner part resists such shrinkage, although usually without complete success. At this period the surface is in tension, tending to compress the inner part much as a rubber band around a book tends to compress the book. Often such tension becomes severe enough to rupture the surface fibers, the results appearing then as surface checks and as end checks. Sometimes these checks do not penetrate very far into the pieces, so that later, when the interior dries and shrinks, they may close, though they never heal.

## MOISTURE GRADIENT

Some shrinkage will develop as soon as drying begins, but it is only surface shrinkage. Should the condition of drying be such that the surface would dry to a very low moisture content<sup>6</sup> soon after the piece entered the kiln, a sharp difference in moisture content would develop between the surface and the parts just below it, on account of the resistance of the wood substance to transfusion of moisture. Such a difference in moisture content, which causes a flow of moisture from the part of high content to that of low, sets up the condition called a moisture gradient. A moisture gradient is most conveniently represented by a curve because it is a change in condition. (Figs. 1 and 2.) A steep moisture gradient practically at the surface brings about two undesirable effects, surface checking and surface set. The term "surface checking" is self-explanatory. Surface set, which will be explained later, causes casehardening, it may cause honeycombing, with or without surface checking, and it contributes to other conditions that ultimately result in degrade.

Obviously, if stock could be dried without setting up a moisture gradient, then shrinkage problems could be reduced to a negligible minimum. Actually, however, a moisture gradient is necessary to create transfusion and drying can not take place without transfusion, although on the other hand the gradient must not be too steep because of the bad results that follow excessive steepness. The moisture content at the surface is determined by the drying conditions to which the surface is subjected, these conditions being the temperature, the humidity, and the circulation of the surrounding atmosphere. It is necessary to consider these factors in some detail in order to understand more fully the part each one plays in the principles involved in seasoning.

## TEMPERATURE

Temperature is an index of the heat condition of a substance. Degrees of temperature represent intensities of heat. Temperature and heat are so closely associated that a discussion of either practically always involves the other.

## CONSUMPTION OF HEAT

Heat is required to evaporate the moisture in lumber as it comes to the surface of the piece. Evaporation consumes heat, and continuous evaporation consequently requires a continuous supply of heat. The fact that evaporation consumes heat can be readily understood by any one who has passed around a pile of lumber in an air-seasoning yard on a warm, sunny day. The air on the side against which the wind is blowing will be relatively warm, while on the opposite side and below the pile it will be several degrees cooler. Furthermore, if the lumber has been freshly stacked and is full of water the cooling effect will be more noticeable than that around old piles of nearly dry lumber, because of the greater amount of evapora-

<sup>6</sup> Moisture content may be defined as the ratio of the weight of moisture present in wood to the weight of the dry wood substance; it is always expressed in per cent. Methods of determining moisture content will be described later (p. 46).

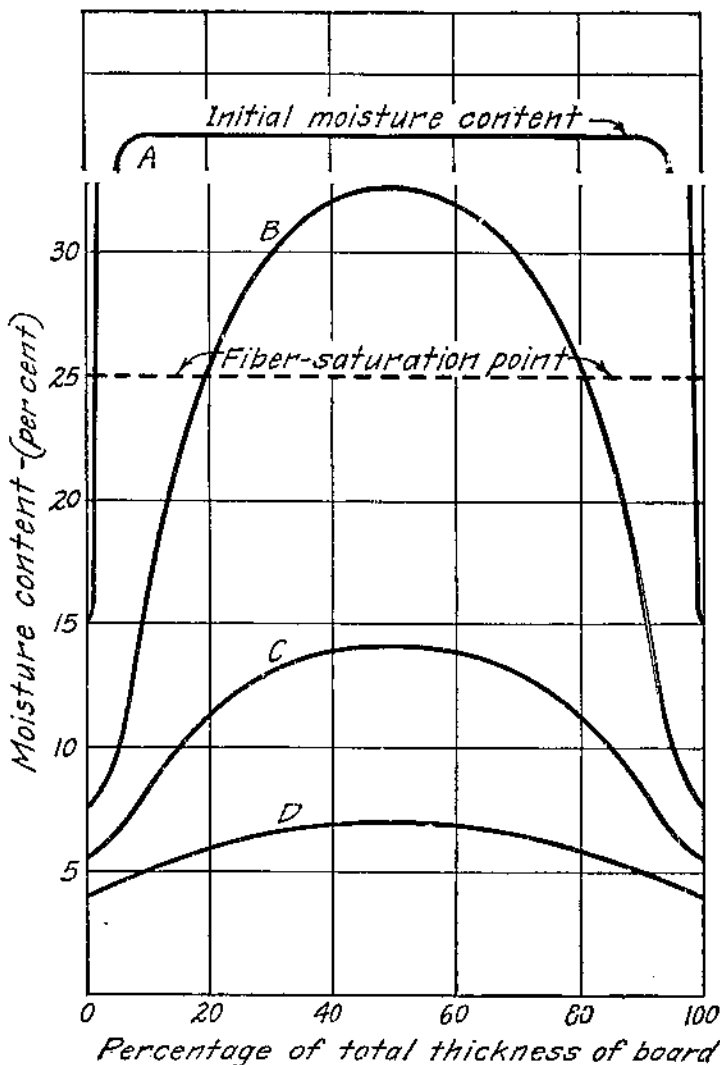

FIGURE 1.—A graphical illustration of typical moisture gradients, across the thickness of a board in the entering-air portion of the pile, at four stages in the drying of No. 1 Common and Better southern yellow pine. The horizontal line at the bottom of the figure represents a line running through the board from face to back, perpendicular to the face, at any representative part of the board (the moisture gradients near the edges and the ends of a board differ somewhat from the typical gradient). The point marked "0" represents any typical point in the face of the board. Hence distances from the vertical line at the left of the figure, which is called the vertical axis, represent distances in from the face of the board. Consequently, each point on one of the curves represents the moisture content (see the scale at the left) of the wood at the spot in any cross section of the board that is indicated by the distance of the point from the vertical axis. Each curve, therefore, shows the change in moisture content along a straight path squarely through the board. Curve A is intended to represent the moisture gradient at the end of the 5-hour period of Schedule 107 (p. 43), shortly after drying has commenced. The moisture content in the center of the board then is still very high, but that at the surface has practically reached equilibrium with the surrounding atmosphere. The value of the moisture content at the surface—the boundary condition—is fixed definitely by the temperature of the surrounding atmosphere, the humidity, and the rate of circulation, while the moisture within the board may differ more or less from the values shown because of variation both in the initial moisture content and in the rate of drying (which is affected by the structure of the wood), and because of the presence of heartwood, sapwood, and pitch. Curve B illustrates similarly the average moisture gradient in a board after 35 hours in the kiln, curve C that after 59 hours, and curve D that at the end of the run.



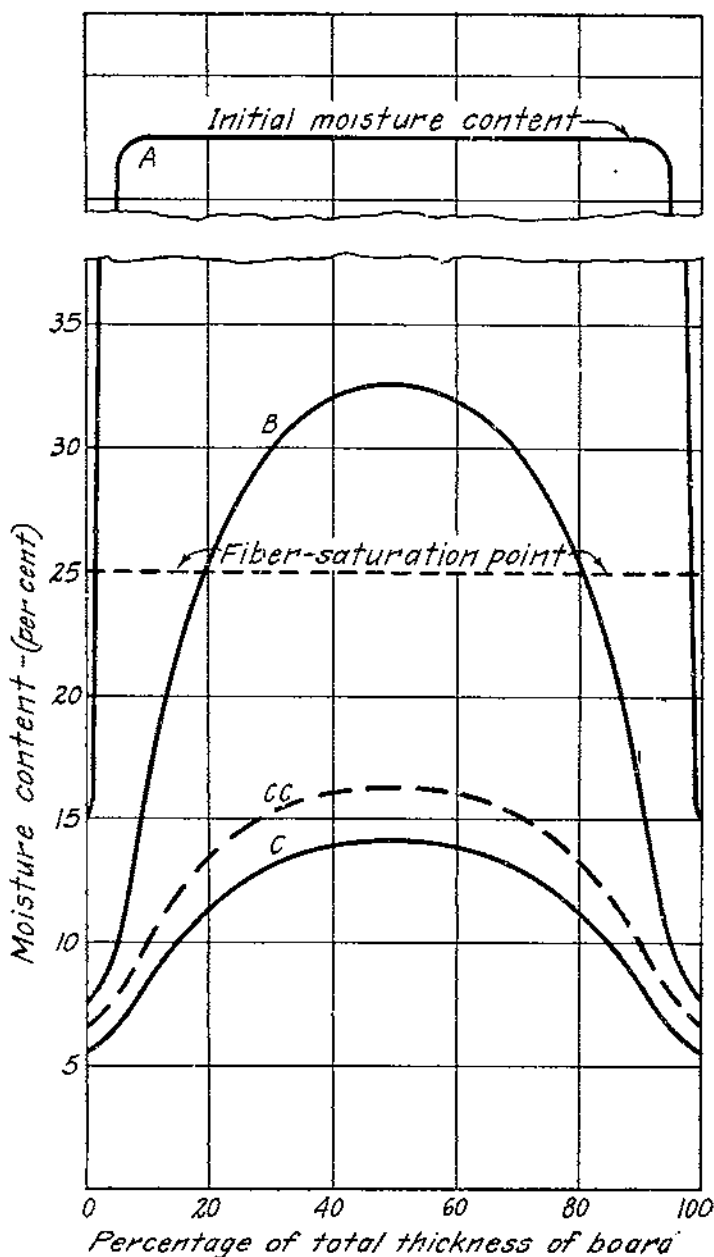

FIGURE 2.—A graphical illustration of moisture gradients, across the thickness of a board in the entering-air portion of the pile, at four stages in the drying of No. 2 Common and lower grades of southern yellow pine. Curve A is intended to represent the moisture gradient at the end of the 5-hour period of Schedule 108 (p. 44), shortly after drying has commenced. Curve B illustrates similarly the average moisture gradient in a board after 35 hours in the kiln, and curve C that for ordinary No. 2 Common stock at the end of the run. Curve CC shows the probable final conditions when the schedule has been modified, giving a higher final moisture content, for stock containing large knots. For further explanation see Figure 1.

tion from the green wood. Hot, dry air passing through a truck load of wet lumber in a kiln will emerge several degrees cooler than when it entered.

The heat, measured in British thermal units, needed to separate water from wood by evaporation increases as the wood dries below the fiber-saturation point. Such increase is small, however, when compared with the heat necessary to evaporate free water. For example, under usual conditions about 1,000 British thermal units is required to evaporate 1 pound of free water and only about 135 British thermal units additional is required when the water is absorbed by wood substance.

#### THE EFFECTS OF HEAT AT A HIGH TEMPERATURE

The transfusion of moisture through wood is stimulated by heat. Since in commercial work the rate of drying is limited by the rate of transfusion and heat stimulates transfusion, it follows that the higher the temperature the faster the drying, other conditions remaining constant.

The moisture-holding capacity of air is much greater at high temperatures than at low. Because of its increased capacity a given amount of dry air at a high temperature will carry away more moisture than at a low one.

Heat is used to produce circulation of the air in a dry kiln. In all kilns not equipped with mechanical means for moving the air, circulation is a result of differences in temperature, heat causing the air to rise and the cooling resulting from evaporation and radiation losses causing it to fall.

In addition to the foregoing there are several other ways in which heat plays an important part in drying. At the temperatures common in kiln-drying southern yellow pine, for instance, heat will kill the fungous organisms that cause mold, stain, and decay. Further, heat in combination with moisture makes wood somewhat more plastic than it is when cold or dry, a fact that may be used to reduce stresses caused by uneven shrinkage. Besides these things, heat affects both the color and the strength of wood and accordingly good practice requires that kiln temperatures be kept below the temperature that might cause appreciable weakening or discoloration. This bulletin, however, is not primarily concerned with any reduction in strength properties that may result from drying under the schedules presented herein; these schedules are milder than those that have been customary for southern yellow pine lumber in the past.

#### HUMIDITY

Establishing high temperatures in order to hasten drying and then maintaining relative humidities<sup>a</sup> that reduce the rate of evaporation may seem inconsistent. As stated earlier, however, the factor con-

<sup>a</sup>The term "relative humidity" refers to the ratio of moisture actually present in the air to the maximum amount the air can hold at the same temperature; it is expressed in per cent. The amount of moisture the air can hold varies with its temperature. At any given temperature the greatest amount of water vapor that air can hold is fixed, but any less amount than this maximum may occur. Increasing the temperature of air increases its capacity for moisture and thus, with the same amount of water vapor present, reduces the relative humidity. Lowering the temperature decreases its moisture-carrying capacity and therefore increases the relative humidity.

trolling the rapidity of seasoning is transfusion rather than surface drying. Although rapid transfusion requires a high temperature, at the same time good drying requires that the moisture gradient shall not be too steep.

#### EQUILIBRIUM MOISTURE CONTENT

Wood is a hygroscopic material; that is, it has the property of taking up or of giving off moisture according to the conditions to which it is subjected. Air (or more properly the space occupied by air) has the same property. If wet wood is placed in a dry atmosphere the air will take moisture from the wood and if dry wood is subjected to damp air it will take up moisture from the air. At any given temperature there is a definite relation, called

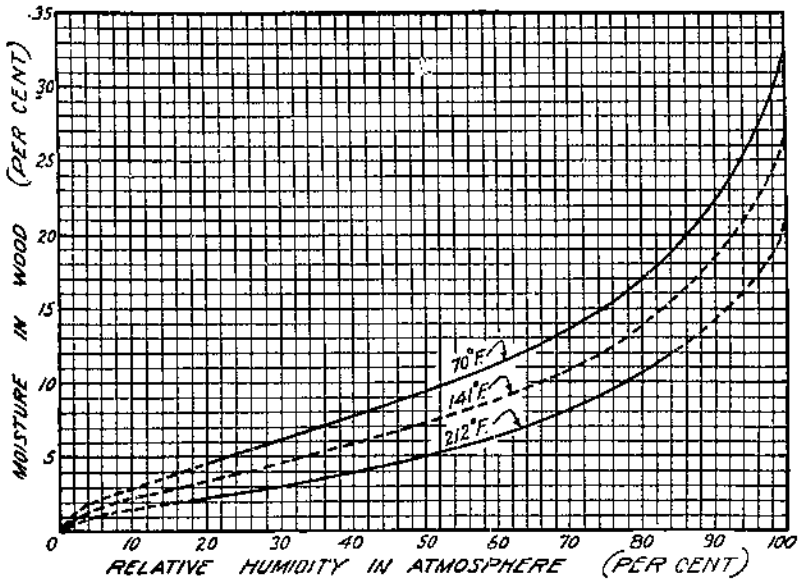

FIGURE 3.—Relation of the equilibrium moisture content of wood to the relative humidity of the surrounding atmosphere, at three temperatures

the point of equilibrium, between the moisture content of wood and the relative humidity of the atmosphere when the wood and the air have been in contact long enough to reach a constant condition. An equilibrium moisture-content curve, which has been worked out with a fair degree of accuracy, is illustrated in Figure 3. This curve shows that the higher the temperature the lower the equilibrium point, at a constant relative humidity. For instance, at 75 per cent relative humidity and an ordinary atmospheric temperature of 70° F. the equilibrium moisture content is about 15 per cent, which in most localities corresponds quite closely to thoroughly air-dried stock, while at 212° and 75 per cent relative humidity the moisture content is about 9½ per cent. Knowing the equilibrium moisture content for various temperatures and relative humidities, it is possible to control the surface moisture content by controlling

temperature and humidity, thereby controlling the moisture gradient. This is the basis of proper drying schedules.

### CIRCULATION

A constant movement of the surrounding atmosphere is necessary to carry heat to drying lumber to replace that consumed by evaporation and to carry away the moisture evaporated from the lumber. Southern yellow pine dries with comparative rapidity and consequently a large amount of heat is necessary to maintain the highest permissible rate of evaporation. This in turn means that a rather brisk movement of air is also required; otherwise evaporation does not take place uniformly throughout the pile. If air enters a pile of green lumber at 175° F. and 70 per cent relative humidity and is cooled by evaporation to 160° it will become saturated. This condition is frequently seen at the green end of a progressive kiln for several hours after it has received a fresh load of southern yellow pine. The air entering the top of the load and progressing downward through the pile becomes saturated in the first few feet of travel and then the lower part of the load, not having received enough heat to warm it, cools the saturated air still further and thus condenses some of the moisture; the condensation may be seen dripping from the bottom of the load. With a more brisk movement the air could travel through the pile so fast that it would not become saturated and would therefore quickly begin to dry stock not only where it enters but also throughout the pile, including the point where it leaves.

### EFFECT OF SHRINKAGE AND OF SWELLING

It has already been pointed out that shrinkage forms the basis of practically all drying difficulties. With results of shrinkage eliminated, drying would present no problems of consequence; actually, however, the whole system of seasoning revolves around this important factor. Although shrinkage can not be prevented in drying nor swelling in reabsorption of moisture, an understanding of these phenomena will make it easier to understand how the results of shrinkage and swelling may be minimized. It may be well to repeat that shrinkage begins when the free water has been evaporated from a cell and the moisture contained in the cell wall begins to dry out (p. 3). From this point on to an oven-dry condition the shrinkage ordinarily is almost directly proportional to the amount of moisture lost. Conversely, when wood absorbs moisture the expansion normally is proportional to the amount of moisture gained, up to the fiber-saturation point. The fiber-saturation point in southern yellow pine is at about 25 per cent moisture content, while the moisture content of green stock may be considerably over 100 per cent of the oven-dry weight. There is a slight shrinkage from the very beginning of the drying period because the outer fibers dry below the fiber-saturation point long before the bulk of the piece reaches that point.

### RELATION OF SHRINKAGE AND DIRECTION OF GRAIN

The physical structure of wood is such that shrinkage is unequal in directions that differ with respect to the grain. In normal,

straight-grained southern yellow pine there is practically no shrinkage along the grain, but across the grain radially the total shrinkage averages about 5 per cent and across the grain tangentially about 7 per cent.

The shrinkage in longleaf<sup>7</sup> pine lumber is slightly greater than that in shortleaf and loblolly, and there also is a slight difference in this respect between heartwood and sapwood of the same species. The average shrinkage of longleaf pine first air dried at about 70° F. and finally oven dried in order to obtain complete shrinkage is shown in Figure 4, and that for shortleaf and loblolly pine in Figure 5; the shrinkages of loblolly and of shortleaf are substantially the same. A few individual test pieces varied as much as 40 per cent above or below the values given, but 67 per cent of the stock ordinarily cut, if dried to 12.5 per cent moisture content, will fall within 1 per cent of the shrinkage indicated for its species for that value of moisture content. Above 12.5 per cent the limits fall closer and closer to the average value until they practically coincide at the upper range of moisture content given.

Normal shrinkage in a board is practically proportional to the amount of moisture the board has lost below the fiber-saturation point (p. 42). For instance, referring to the curve of radial shrinkage in longleaf heartwood (fig. 4), a heart board dried to 10 per cent moisture content will shrink radially only 3 per cent from its green dimension, that is, about three-fifths of the average shrinkage for zero moisture content. Similarly, at the other extreme, a piece of longleaf sapwood dried to 10 per cent moisture content will shrink tangentially approximately 4.5 per cent of its green dimension, that is, also about three-fifths of the average total shrinkage. Since few pieces of lumber are either truly radially grained or truly tangentially grained, however, in commercial work shrinkage may be considered proportional to the amount of moisture lost below the fiber-saturation point, and the amount of shrinkage may then be estimated roughly on this basis. For example, the shrinkage of a piece at 10 per cent moisture content may be taken as  $\frac{25-10}{25} = 15/25$  or three-fifths of its average total shrinkage, which is about 6 per cent across the grain and about 12 per cent in volume for southern yellow pine.

Certain kinds of abnormal wood, that is, wood with parts of abnormal growth or with diagonal or crooked grain, will shrink lengthwise of the board. This is usually because the shrinkage across the grain effects the length of the board when the grain is diagonal or crooked. For instance, the irregular grain around knots will cause localized longitudinal shrinkage. "Compression wood" is a name given to a growth condition found at times in many softwoods, including southern yellow pine; in its most common form the pith of the tree is off center, with wide, heavy, annual growth rings on one side of the pith and narrow rings on the other. Boards cut so as to contain some of the heavy rings, the actual compression wood, will shrink longitudinally, thus forming an exception to the general rule for lengthwise shrinkage. Crook is almost always associated with

<sup>7</sup> The names of species appearing in this bulletin are the standard common names given in the Check List of the Forest Trees of the United States, Their Names and Ranges (2).

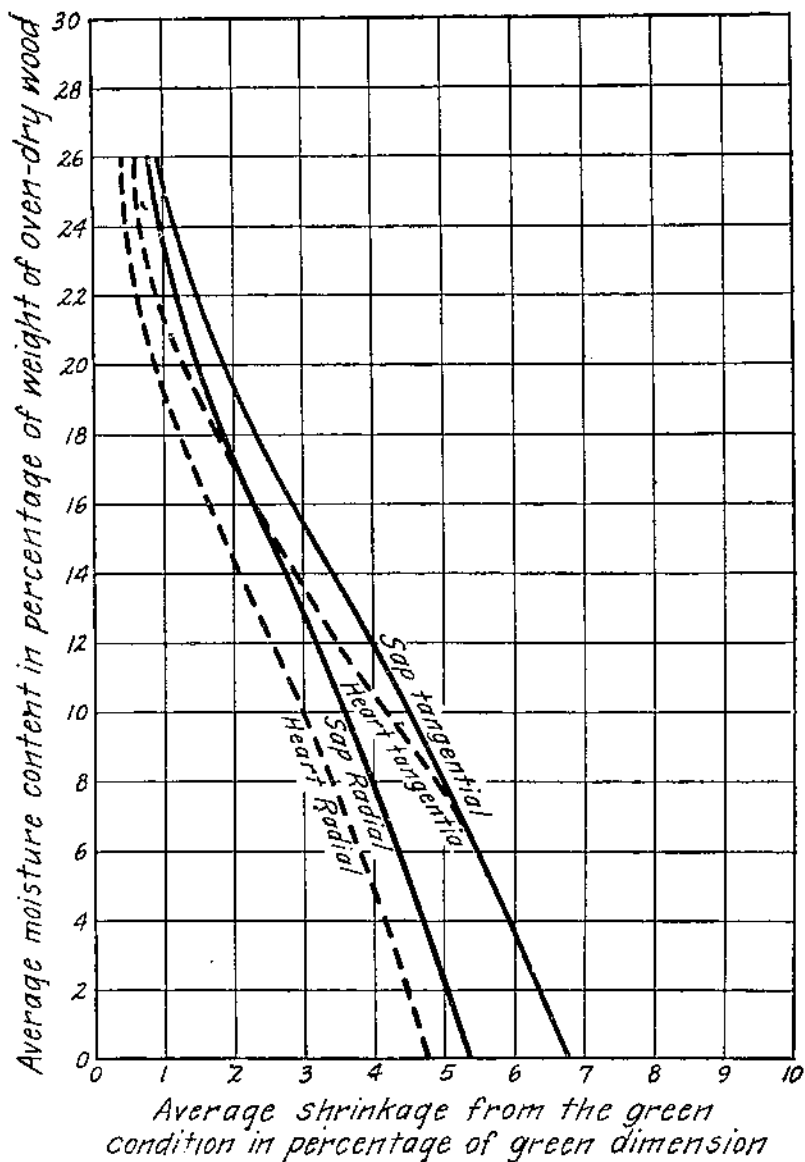

FIGURE 5.—Average shrinkage, with decrease in moisture content, of 1 by 6 inch green commercial longleaf pine boards dried under conditions closely equivalent to ordinary summer weather in the southern pine region, except that the final conditions ultimately brought the moisture content to zero

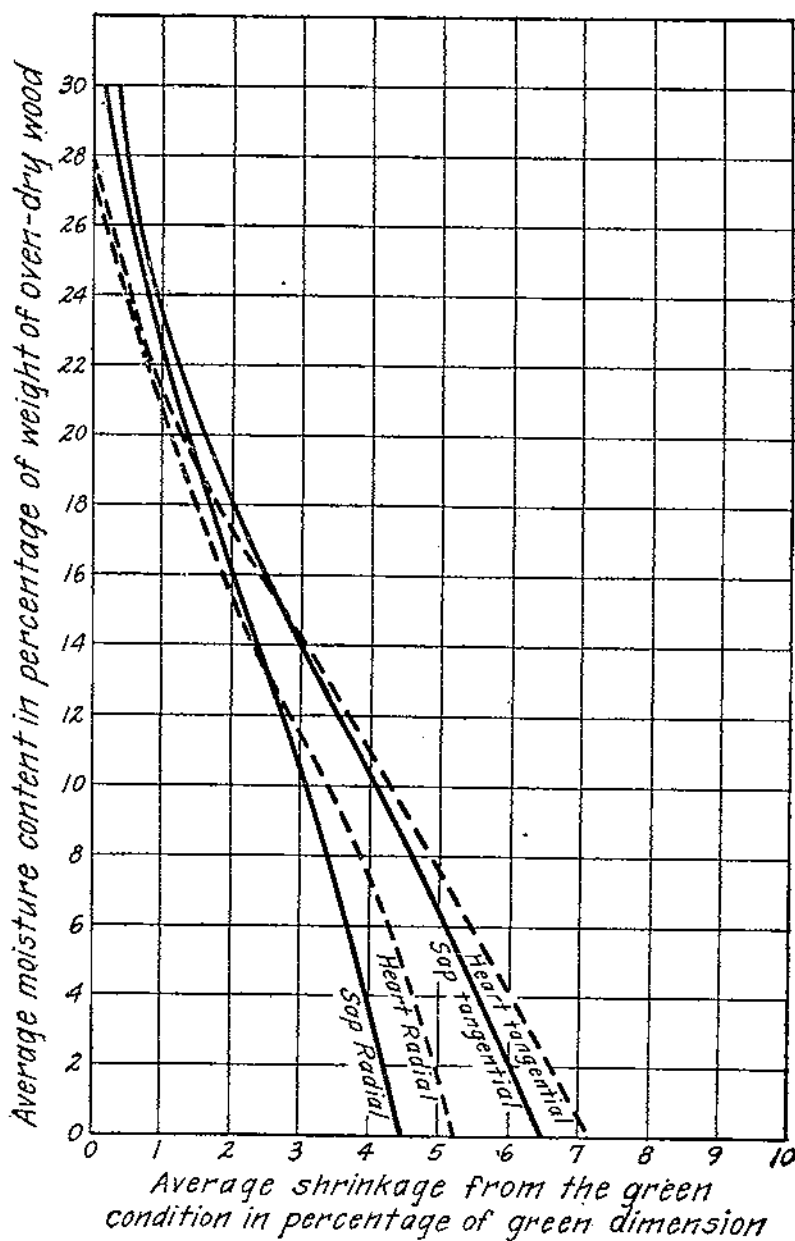

FIGURE 5.—Average shrinkage, with decrease in moisture content, of 1 by 6 inch green commercial shortleaf and loblolly pine boards dried under conditions closely equivalent to ordinary summer weather in the southern pine region, except that the final conditions ultimately brought the moisture content to zero

compression wood; when a board is crooked because of compression wood, one of its edges contains more compression wood than the other. (Pl. 1.)

The term "compression wood" should not be confused with compression stress, which will be discussed in connection with checks and casehardening.

#### CHECKS

Surface and end checks in lumber are a result of two shrinkage factors, one of which is the difference in shrinkage between the surface and the interior of the piece and the other the difference between radial and tangential shrinkage. They occur during the period when the surface is in tension and the center in compression. (See "Casehardening," p. 14.) Checks should not be confused with planer splits, which are caused by an entirely different condition in the lumber.

#### HONEYCOMBING

Honeycombing is a rupture in the interior of the piece along the grain of the fibers, a condition sometimes referred to as internal checking. It occurs during the final period of drying, when the surface is in compression and the interior in tension. Honeycombing is very uncommon in 4/4-inch and 6/4-inch southern yellow pine, but is sometimes found in stock over six quarter inches in thickness.

#### KNOTS

Loose, checked, and broken knots, which are responsible for a high percentage of the degrade in the common grades of southern yellow pine lumber, are caused by some combination of the following three laws of shrinkage: (1) The exposed surface of the knot, which is end grain, dries more rapidly than the portion of the board surrounding it, and consequently shrinks away from the board while the board is too wet to shrink. (2) Wood shrinks very little along the grain but considerably across the grain. As a result the knot shrinks in all directions on the face of the board, but not much in thickness, whereas the board shrinks in width and in thickness but not much in length. After drying, although the knot is thicker than the board it tends to occupy a smaller cross-sectional area than that of the space for it in the board, and therefore it usually has either checked or become loose. Incased and dead knots are most likely to become loose and fall out. Live or intergrown knots are least subject to damage, and that which occurs is usually checking or breaking in the planer. Knots that might otherwise be held by growth tissue or friction are likely to be loosened in the planer because of both their hardness and the abuse they receive from the planer knives. (3) Heavy or dense wood shrinks more than light wood and, since knots are more dense than the surrounding stock, their percentage of total shrinkage is greater. White and red knots are frequently so intergrown with the surrounding stock that the bond thus formed is stronger than the knots, causing them to check or split in drying.

The size of the knot is also an important factor in knot defects, small knots frequently remaining tight although few large knots go through a planer undamaged. The direction of the grain in knots



and their structure make them more brittle than the surrounding wood and hence more liable to breakage in the planer. Brittleness in knots increases as the moisture content decreases and because of this more breakage will occur in knots in the usual run of kiln-dried stock, which has a relatively low moisture content, than in air-dried stock. The proper method of kiln drying to prevent or at least to reduce the liability of damage to knots will be discussed later (p. 42).

#### CASEHARDENING

Casehardening is the term commonly used to describe a condition in dry lumber that, for instance, causes it to cup when the stock is resawed; the condition is a result of unequal stresses that develop because of unequal shrinkage in the cross section of a board as it dries. Immediately after drying starts the surface of the board dries below the fiber-saturation point and then attempts to shrink. At the same time the wood just beneath the surface is still above the fiber-saturation point and it naturally opposes the surface shrinkage. In this stage the surface fibers squeeze the core, thereby setting up compression stresses in it and tension in themselves. As the drying progresses the outer fibers, because of the restraint of the adjoining wet inner fibers, shrink less than they would if they were free and as a result they become set. With still further progress in drying, successive layers of fibers beneath the surface dry below the fiber-saturation point and each in turn is restrained, first by the inner portion of the piece and ultimately, when the core has dried, by the outer portion. While the surface is drying it is in tension and the center of the piece is in compression; during the later stage of drying the center is in tension and the surface in compression. Since the core is the last to try to shrink it continues to exert an internal pull after the entire piece is dry. When stock is in this condition, with the surface in compression and the core in tension, it is case-hardened; if resawed, it would cup at once, even though the moisture content between the surface and the center were uniform.

When a combination of unbalanced tension and compression stresses occurs in opposite faces of a piece of lumber it causes cupping unless the stresses are either counteracted by restraint of the piece or are relieved. Lumber that has more moisture in the center than in the outer portion will always cup more or less after resawing. (Pl. 2.) Such unequal moisture distribution in casehardened stock still further complicates the cupping, because of the shrinkage that results from the equalization of moisture throughout the piece after resawing.

Casehardening is most severe in unrelieved lumber that has had a steep moisture gradient; such a gradient occurs in the stock in kilns where the drying conditions are very severe. Casehardening in air-dried southern yellow pine is almost unknown, and it can be minimized in dry kilns by the use of proper drying schedules.

#### CHARACTERISTICS OF SOUTHERN YELLOW PINE THAT AFFECT KILN DRYING

Some kinds of southern yellow pine lumber react differently from others during the seasoning process, and accordingly the kiln operator should understand thoroughly both the characteristic differences

among the species and those resulting from various growth conditions. Proper consideration of these differences will reduce drying hazards and will speed up the drying process. Stock cut from dense stands will have fewer knots, and less of the seasoning difficulty they cause, than that cut from open stands. Lumber cut from small trees will cup and twist more than stock cut from trees of large diameter. Dense-growth, heavy stock seasons more slowly than lighter stock and is more inclined to warp and check, because dense wood shrinks more than light wood. Hard, heavy, wide-ringed second-growth longleaf pine also contains more moisture than narrow-ringed virgin-growth stock. The same is true of wide-ringed oldfield<sup>8</sup> pine, but it is often less dense than virgin growth. Obviously a larger quantity of moisture to be evaporated adds time to the seasoning process. Second-growth stock will usually contain more sapwood than will virgin or mature-growth stock, and green sapwood always contains more moisture than heartwood, oftentimes more than twice as much. Heartwood of both longleaf and shortleaf pine will contain moisture ranging from 25 to 50 per cent of the weight of the wood, while sapwood contains from 70 to 130 per cent in longleaf and up to 180 per cent in shortleaf. Red heart,<sup>9</sup> which is very common in some localities, usually reduces the moisture content to less than 25 per cent and, therefore, lumber affected with red heart can be dried more rapidly than sound lumber.

Pitch acts as a retardant to moisture transfusion and consequently stock that is heavy with pitch may require twice as long to season as clear stock. It frequently happens that a heavy pitch streak will extend along one face of a board while the other face will be normal, clear stock, a condition that results in unequal drying, usually followed eventually by warping. Sometimes logs that have been lying in the woods for a long time are brought into the mill; the sapwood may be blue stained and the lumber smells sour when the log is cut up. The sapwood from such logs and also that from deadheads dries much more slowly than the sapwood from fresh logs. The moisture content of several sour longleaf pine boards, after four days in a kiln, ranged from 45 to 55 per cent,<sup>10</sup> while the other stock in the same truck load averaged about 7 per cent.

### SEASONING TO SUIT MARKETS

The seasoning problem of each southern pine manufacturer is affected by the market in which his stock is sold. On the other hand, the standard of seasoning followed may be the deciding factor in determining the market, low standards limiting it and high standards extending it to include special-purpose material and even premium prices for yard stock. The market for the mill output is influenced by such factors as the following: Species of pine, grades

<sup>8</sup> "Oldfield pine," as used in the southern lumber regions, designates a growth condition of southern yellow pine and not a species. It is customarily applied to the type of shortleaf and of loblolly pine that has grown in abandoned clearings and consequently has certain ring-growth and knot characteristics that differentiate it, in the mill-man's identification, from all forest-grown trees, either virgin growth or second growth.

<sup>9</sup> Red heart is a stage of incipient decay characterized by a reddish color in the heartwood. "Firm red heart" is the term used to describe the defect in stock where the disintegration processes have not proceeded far enough to affect the hardness of the wood perceptibly. Red heart may occur either in a part or in substantially all of a board.

<sup>10</sup> See footnote 6 on p. 4.

of lumber manufactured, quality of product, price, sales organization, type and size and location of mill, method of transportation, and location of market. In one way or another each of these factors has more or less bearing on the method and the degree of seasoning. Actually, for domestic markets, it is the ultimate use or use requirements that should establish the degree and the standard of seasoning. Lumber grades and their prices practically establish the purposes for which stock will be used; hence, for all ordinary service, seasoning standards may be based on such grades. Building construction absorbs the major portion of the southern yellow pine manufactured. In such construction the upper grades of lumber, No. 1 Common and Better, are required for interior finish, exterior finish, flooring, and other planing-mill products, all of which are used where shrinkage and swelling are objectionable and consequently well-seasoned stock is necessary. The lower grades of lumber are used in rough construction work like side wall and roof sheathing, subfloors, and concrete forms, in which some shrinkage can be accepted without materially affecting the appearance of the finished structure. In such uses the standard of seasoning required is not so high as it is for the upper grades. Studs, joists, and small timbers are often air dried, not kiln dried, and larger timbers are often shipped without any seasoning. Manufacturers of railway cars, automobile bodies, furniture, refrigerators, and other special products usually specify the moisture content that is acceptable to them for the items and grades they purchase.

Quite apart from the question of use requirements, the lumber manufacturer gains several advantages if his stock is properly seasoned. Since rail-transportation charges for a given commodity and length of haul are based on weight, lumber of low-moisture content naturally enjoys a lower shipping charge per thousand board feet than the heavier lumber of higher moisture content. In addition, most southern yellow pine lumber is used in finished sizes, and the manufacturer finds that unless the stock is reasonably dry it does not machine properly. Further, stock is far less likely to develop blue stain if it is kiln dried than if it is not, and unstained stock has a decided sales advantage over stained.

#### COMPARATIVE MERITS OF AIR DRYING AND OF KILN DRYING

The seasoning of southern yellow pine at the sawmill may be accomplished by air drying or by kiln drying or by both. Air drying is the simpler of the two. For air drying the green lumber is merely open piled in a yard equipped with proper foundations; the stock then requires a minimum of attention during the drying process. The construction of buildings is avoided and the size of the yard can easily be changed to accommodate the cut of the mill. Kiln drying is more complicated, involving kiln buildings, tracks, stacking equipment, an adequate supply of steam, and suitable personnel.

Air seasoning, however, is slow and the stock must remain in the yard for months before it is ready for shipment. Thus the yard grows to an accumulation of several months' output of the mill and, further, it is necessary to carry a complete line of dried stock if

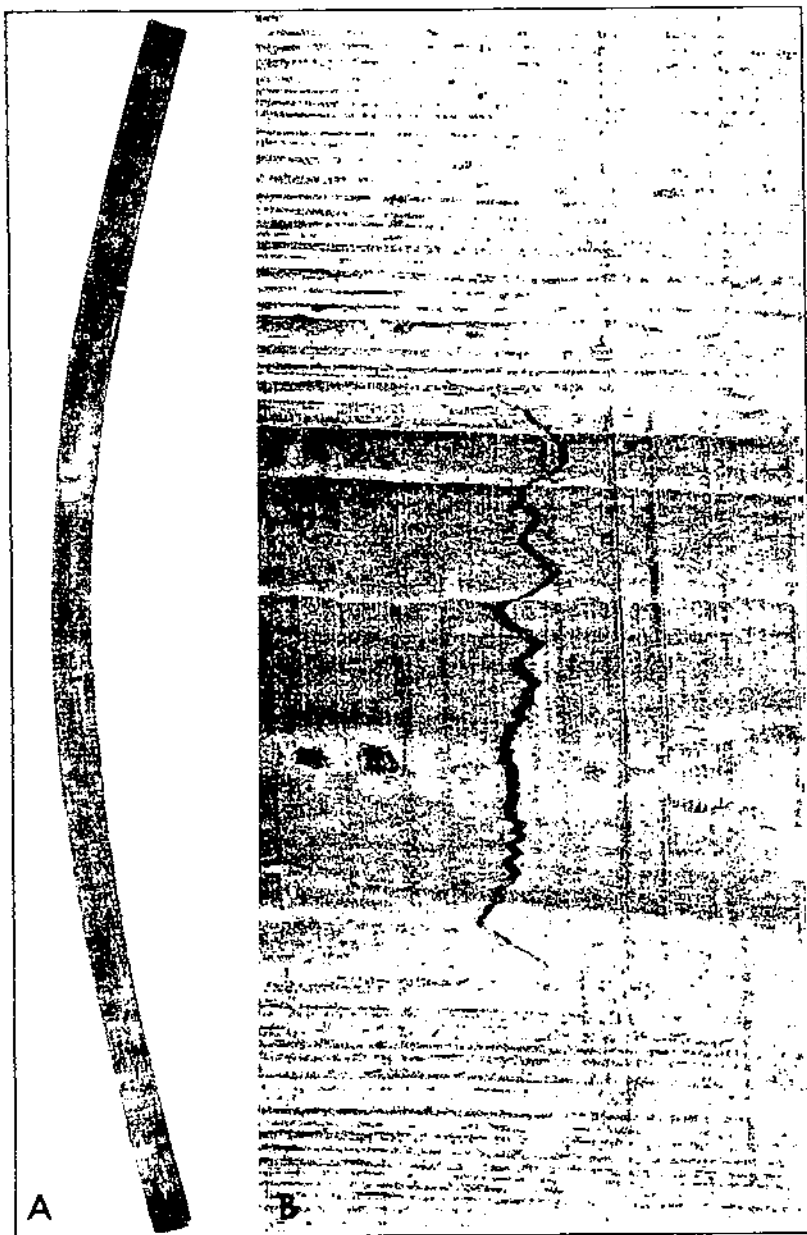

M-11470-F

A. Crack in 1 by 1 inch kiln-dried southern yellow pine, caused by the longitudinal shrinkage of compression wood during drying. B. A typical tension failure in southern yellow pine caused by the longitudinal shrinkage of compression wood during seasoning.

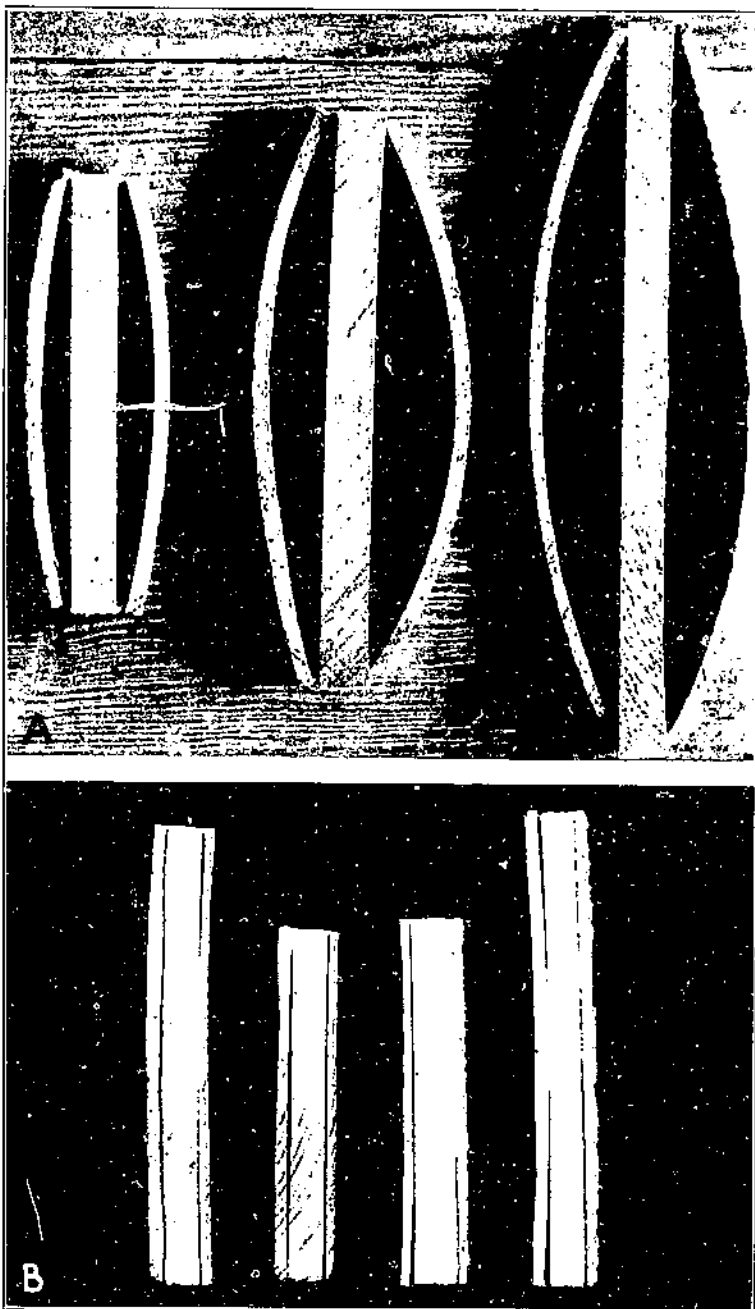

M-1147c-F

A. The cupping that is usual when case-hardened southern yellow pine lumber is resawed before the internal stresses have been relieved. B. Sections of southern yellow pine lumber resawed after case-hardening stresses have been removed by means of a conditioning treatment in the kiln. The internal stresses will also be cut off gradually during storage of case-hardened lumber in the rough-dry shed, but several months must elapse before the results of severe case-hardening will entirely disappear under such treatment.

orders are to be filled promptly. Even then the filling of orders may occasionally be delayed somewhat by unfavorable weather, since in addition to the general slowing down of the seasoning process during cold weather, with the resultant possibility of delay at some future time, is the immediate delay sure to come from rain; stock should not be taken from the pile for some days after a heavy rain.

Kiln drying reduces to a few days the amount of time required for seasoning, and it thus is possible to ship finished lumber within a week or so from the time the log is cut, regardless of the season of the year and regardless of rainy weather. Special orders can be accepted for quick delivery even if no stock of the desired items is on hand.

#### UPPER-GRADE STOCK

In the upper grades the lower moisture content possible with kiln drying is a particular advantage of that method of drying, inasmuch as such stock does not become dry enough in yard seasoning for the use to which it will be put. After kiln drying, moreover, it can be manufactured at the mill into flooring, finish, and special items, thus materially increasing the market price over what would be possible in the same grades air dried.

#### BLUE STAIN

Kiln drying also makes it easy to avoid blue stain, which frequently develops in air drying, especially during hot and humid weather. Such stain reduces the value of upper-grade stock and makes it more difficult to market the lower grades. Chemical treatment of green lumber before air drying—such treatment, for instance, as dipping in a solution of bicarbonate of soda—may be efficacious and under certain conditions is satisfactory. Stock that is soda dipped is not desired in some markets, however, and for certain uses is not desired in any market. Proper kiln drying, on the contrary, prevents blue stain more certainly than any other method now known, and at the same time leaves the stock universally acceptable.

#### LOSSES CAUSED BY FORCING KILNS

The benefits of kiln drying have been so marked that an immense dry-kiln capacity has been put into operation at southern pine saw-mills, and in spite of this capacity the demand from the consumer has been for an increasing percentage of kiln-dried lumber. This demand has led to the operation of dry kilns for their maximum production, instead of for their best production, and consequently severe drying conditions have been maintained. Because of these conditions drying defects are common and frequently the resulting degrade is quite heavy. Along with the general advance in the value of southern yellow pine the price difference between grades has also increased, and accordingly any drop in grade caused by drying defects results in a serious loss in value.

## SURVEY OF KILN-DRYING PRACTICE

## 1921 SURVEY

The necessity for efficient kiln drying became particularly evident as a result of a preliminary survey made by the Southern Pine Association in 1921 to determine the current seasoning practice at association mills. In this survey degrade tests were made at 10 mills on both air-dried and kiln-dried stock. It was found that, when kiln-dried stock was manufactured into finished lumber, nearly a third dropped below the grade into which the stock originally had been cut. B and Better lumber averaged 34.5 per cent degrade, No. 1 Common 30.5 per cent, and No. 2 Common 22.5 per cent. Such drops in grade of course meant a serious loss in the value of the lumber, and while it was not expected that all of the degrade could be eliminated by improved kiln drying it was felt that a substantial reduction might be effected if the exact causes of degrade could be determined. The determination required more information about the conditions under which the lumber was being dried than was then available.

## 1922 SURVEY

The Forest Products Laboratory arranged in 1922 to cooperate with the Southern Pine Association in studying the problems peculiar to the seasoning of pine. The study, which was intended to bring out the cause and the extent of the kiln degrade as well as other factors that might have a bearing on the method of attacking the problem, began with a survey more detailed than that of the previous year. Fourteen representative mills, widely scattered throughout the longleaf and the shortleaf districts, were visited; all these mills had a daily cut of 100,000 board feet or more and were kiln drying a part or all of this cut, and all maintained planing mills.

The conditions found during the survey and in some of the subsequent experiments mentioned herein represent the conditions at the time of observation; at that time they were typical of most of the mills throughout the southern pine area. A number of the southern pine mills have both modified their kilns and otherwise improved their seasoning practice materially since then, but at many of the others the conditions are still about the same as those that existed in 1922.

## EXTENT OF KILN-DRYING PRACTICE

The seasoning practice at the larger southern mills was not uniform. Some plants kiln dried only B and Better stock, some included No. 1 Common, and others part of the No. 2 Common. A few mills kiln dried their entire cut of lumber. The mill operators considered kiln drying of the upper grades profitable because it enabled them to manufacture the better lumber into finished sizes or special items. Some, however, were not convinced that it was profitable or even practical to kiln dry the common grades. Such lumber, being used for less exacting purposes than the upper grades, does not require seasoning to so low a moisture content. Kiln drying of the common grades had often led to a severe loss from degrade and consequently such stock was usually air dried, with a smaller

resulting degrade. Practically all kiln drying of pine at the southern mills is on stock green from the saw. Lumber that is air dried, wholly or in part, is seldom put through their kilns before shipment.

### DRYING CONDITIONS IN THE KILNS

All of the mills visited in the course of the survey were using natural-circulation progressive kilns. High-pressure steam, usually at about 100 pounds gauge pressure and direct from the boilers, was used for heating. The boilers were operated continuously, except at some plants where the steam was shut off over Sundays and holidays.

#### TEMPERATURE

The operation of the kilns commonly consisted only of such attention as that required for loading and unloading, which left the kilns to themselves at all other times. Under such operation the kiln temperatures and humidities were continually changing as the drying progressed. Rapid evaporation from the fresh lumber kept the green or charging end at a lower temperature than the discharge end, the two temperatures ranging from 150° to 180° F. in some kilns and from 180° to 230° in others. The dry-end temperatures were regularly about 20° to 40° higher than those at the green end. Sometimes when the trucks were not removed from the kilns as soon as their loads had become dry temperatures in excess of 250° were observed. Few operators attempted even to determine the kiln temperatures.

#### HUMIDITY

The kiln humidity fluctuated with the temperature and with the amount of moisture being evaporated from the lumber. The highest relative humidities were of course found at the green end; they ranged, a few hours after loading, from 60 per cent in kilns with tight walls and doors to 30 per cent in leaky kilns. In a few instances relative humidities at the green end below 20 per cent were also noted. At the dry end the relative humidities were always comparatively low, seldom exceeding 30 per cent, often below 20, and sometimes less than 10 per cent. The source of humidity in practically all kilns was limited to evaporation from the lumber; in only a few instances were steam sprays used for that purpose. The evaporated moisture, escaping through ventilators and chimney cracks and crevices in doors and walls, left the humidity in the kiln a natural balance between the rate at which the moisture evaporated from the wood and its rate of escape from the kiln. In no case observed was automatic humidity control apparatus installed.

#### CIRCULATION

The air movement, as with all natural-circulation kilns, was dependent upon a combination of conditions, such as the design and distribution of the heating coils, temperature range, relative humidity, and the method of piling. Since the operators did not thoroughly understand the natural laws governing air movement, the benefit derived from control of the factors that affect circulation was a



matter of chance; full advantage of any one factor was rarely obtained.

#### TIME IN THE KILN

The time required for drying green pine lumber varied with the grades of stock and the drying conditions used and to some extent depended upon the stock separation (p. 45). Sap stock required the longest time. No. 1 Common and Better lumber, which is largely sapwood, was being dried in a minimum period of 72 hours, which seemed to be the popular idea of the usual drying time of all 1-inch stock. Observation, however, brought out the fact that a large proportion of this grade was actually in the kiln from 84 to 96 hours. The lower grades contain more heartwood, which has less moisture than sapwood, and, having a higher final moisture content, were being dried in from 48 to 72 hours when separated from the upper grades.

#### MOISTURE CONTENT OF KILN-DRIED STOCK

Tests on the moisture content of kiln-dried stock at various plants, immediately after it had left the kiln, brought out the fact that overdrying was a common occurrence, although expediency often required that stock be removed from the kiln while still underdry. In several lots of B and Better stock tested the average values of moisture content were respectively 2.7, 5.4, 5.5, and 4.0 per cent, and in an underdry load 13.2 per cent. In the dry stock most of the pieces were below 5 per cent moisture content, some as low as 0.8 to 2.0, and an occasional piece was 9 to 10 per cent. In the underdry load mentioned the values ranged from 5 to 21 per cent.

No instance was found where it was a part of plant practice to make positive moisture determinations, the stock being drawn from the kiln simply when the operator was satisfied that it was dry. He determined moisture conditions merely by snapping splinters, cutting into boards, rapping the pile, or, most often, by the time the stock had been in the kiln, practices satisfactory only when the results are checked regularly, at frequent intervals, by an accurate moisture determination, and not satisfactory even then in particular work.

Common grades when dried with the upper grades had about the same moisture content as the upper-grade stock. When dried separately, common stock was pulled out after a shorter time in the kiln and consequently was not so dry.

Lack of uniformity in moisture content seemed to be characteristic of all plants; it was not uncommon to find in some parts of a pile stock that was "burnt up" while other parts were still underdry.

#### EXTENT OF DEGRADE CAUSED BY KILN DRYING

The chief object in making the kiln-drying survey was to determine as far as possible the extent of and the cause for degrade in southern yellow pine lumber. Consequently degrade tests were made at a number of plants in accordance with a method that will be described later. The method of determination was such that only degrade caused by drying defects appeared on the records. The

stock tested was dried in the usual manner in the kiln, was allowed to stand for 24 hours before going to the planers, and was then graded immediately behind the planer by an association inspector. The cause of degrade, such as checks, warp, or damaged knots, was recorded. The results of these tests are given in Table 1. This table shows, for instance, that, at mill 1, 78.8 per cent of the B and Better stock remained on grade, 15.1 per cent fell to No. 1 Common, 4.2 per cent to No. 2 Common, and 1.2 per cent to No. 3 Common. The remaining 0.7 per cent, which was trimmed off, was considered as waste. Thus 20.5 per cent was reduced one or more grades on account of drying defects of one kind or another. The actual loss of lumber was small, being less than 1 per cent. The significant loss, that in the value of the stock, was far from small, however, the average being \$6.15 per thousand board feet. The greatest loss came in the wider stock but, since the test was on mill-run width, the total loss was representative of mill-run B and Better stock at that plant.

TABLE 1.—The extent and the cost of degrade of southern yellow pine lumber, as determined by grading behind the planers, caused by improper methods in kiln-drying practice at representative mills during 1922 and 1923

Grade as placed in kiln	Item	Mill No. 1	Mill No. 2	Mill No. 3	Mill No. 4	Demonstration run
B and Better	Species of pine.....	Longleaf.	Shortleaf.	Shortleaf.	Shortleaf.	Shortleaf.
	Board feet graded.....	2,405	1,501	4,536	5,053	4,790
	Mill-run stock, size in inches.....	1 by 4 to 1 by 12	1 by 8 to 1 by 12	1 by 4 to 1 by 12	1 by 4 to 1 by 12	1 by 4 to 1 by 12
	Drying time..... hours	66	72	72	72	84
	Final grades: <sup>1</sup>					
	On grade..... per cent.	78.8	71.1	86.7	76.7	94.2
	Degraded to No. 1 Common..... do	15.1	13.6	4.7	17.9	3.6
	Degraded to No. 2 Common..... do	4.2	8.0	6.7	5.4	2.0
	Degraded to No. 3 Common..... do	1.2	2.4			
	Waste..... do	.7	4.9			
No. 1 Common	Loss per 1,000 board feet <sup>2</sup> ..... dollars	0.15	11.64	1.9	5.88	1.76
	Board feet graded.....	3,134	2,407	4,555	5,212	4,652
	Mill-run stock, size in inches.....	1 by 4 to 1 by 12	1 by 8 to 1 by 12	1 by 10	1 by 4 to 1 by 12	1 by 4 to 1 by 12
	Drying time..... hours	66	72	72	72	50
	Final grades: <sup>1</sup>					
	On grade..... per cent.	54.9	50.3	91.2	83.8	72.3
	Degraded to No. 2 Common..... do	43.9	22.7	8.6	13.8	24.3
	Degraded to No. 3 Common..... do	.4	21.1		1.2	3.4
	Degraded to No. 4 Common..... do	.4	3.5			
	Waste..... do	.4	2.4	1.2		
No. 2 Common	Loss per 1,000 board feet <sup>2</sup> ..... dollars	7.30	9.51	1.74	3.74	4.04
	Board feet graded.....	2,307		4,744	4,374	4,913
	Mill-run stock, size in inches.....	1 by 4 to 1 by 12		1 by 4 to 1 by 12	1 by 4 to 1 by 12	1 by 4 to 1 by 12
	Drying time..... hours	66		72	72	50
	Final grades: <sup>1</sup>					
	On grade..... per cent.	73.4		64.7	72.9	87.9
	Degraded to No. 3 Common..... do	24.9		34.6	27.1	11.8
	Waste..... do	1.7		.7		.3
	Loss per 1,000 board feet <sup>2</sup> ..... dollars	1.70		1.88	1.23	.62

<sup>1</sup> Defects caused by imperfect manufacture were not considered in determining the degrade caused by drying.

<sup>2</sup> The reductions in value are based on the Southern Pine Association's sales report of Mar. 10, 1923.

<sup>3</sup> This stock was bulk piled for 30 days. All other stock was manufactured 24 hours after leaving the dry kilns.

The degrade and waste for No. 1 Common stock, 45.1 per cent, was considerably greater than for B and Better; the loss averaged \$7.30 per thousand board feet. The degrade in No. 2 Common, on the other hand, does not represent so great a monetary loss even when the percentage of degrade is as high as in the upper grades, because the difference in value between No. 2 Common and No. 3 Common is much less than that between No. 1 Common and No. 2 Common, or between B and Better and No. 1 Common.

The tests on the same grades at other mills varied somewhat, but in the main were consistent with the degrades at mill 1. The big difference between the B and Better stock at mill 1 and at mill 2 is one of width, the wide stock degrading more than the narrow.

#### BULK PILING

Some mills had rough storage sheds in which the kiln-dried stock, particularly the upper grades, was held in bulk for a period before manufacture. Where this practice is followed the degrade is not so great as where stock is run direct from the kiln to the planer. Since at that time bulk-piling stock after drying it was not common, the practice was omitted from the study included in the survey of 1922.

#### CONCLUSIONS DRAWN FROM SURVEY

To sum up the situation as it appeared after the 1922 survey, the degrade caused by the seasoning practice then current was altogether too high, drying conditions were too harsh, and very few of the millmen appreciated the fact that there was something more to drying than merely evaporating the moisture in the wood. No serious attempt was being made to control drying conditions, to learn what drying conditions existed in the kiln, or to ascertain what such conditions meant in terms of grade reduction and loss in value.

Since 1922 conditions have improved at many of the mills visited and, of course, at many of those not visited. New kilns have been built and old ones modified, temperature-control and humidity-control apparatus has been installed, and the personnel have a better idea of how to keep drying losses under some control. Unfortunately, there still are many mills where conditions have not been improved and others where some alterations in kilns and equipment have been made with little or no resultant improvement. The mills that have forged ahead have done so because their executives recognized that an understanding of the principles of drying was necessary for the best results and set about improving both personnel and kilns in order that such principles could be understood and followed.

#### EXPERIMENTS AT COMMERCIAL PLANTS

##### EXPERIMENTS ON SHORTLEAF PINE

The 1922 survey had shown that the severity of the current drying conditions was largely responsible for the degrade in kiln-dried lumber. The initial step in reducing such degrade was to determine (1) the temperature and the humidity that would give the best results,

and (2) the practicability of obtaining such conditions in commercial kilns. Accordingly one of the progressive kilns at a plant in Texas was modified by installing steam sprays at the dry end for humidity control, and certain minor changes were made in the heating coils. Automatic temperature and humidity control was installed with the object of operating the kiln under a drying schedule that used humidities higher than those normally secured at that time in the average natural-circulation kiln. Subsequent experiments demonstrated that it was possible, by using higher final humidities, to dry B and Better stock with a degrade of about one-fourth the amount generally obtained but that the drying time exceeded the time required in the regular kiln. The influence of the higher final humidities on the circulation in the kiln and the effect of the circulation itself on the rate and the uniformity of drying will be described later. It will be sufficient here to say that, in natural-circulation kilns, circulation decreases as the humidity increases, and rapid and uniform drying requires a good circulation. In the modified natural-circulation progressive kiln used in the experiments it was impossible to get sufficient circulation when maintaining the higher humidities required for the common grades, and such stock, when dried so as to obtain a lower degrade, could not be dried in this kiln within a reasonable time.

The experiments demonstrated the need for further tests in a kiln equipped to provide a greater circulation than that obtainable by natural means in the ordinary type of progressive kiln. It was decided that best results could be obtained when the kiln circulation was independent of humidity.

Consequently another lumber company, also in Texas, turned over one of their kilns for the purpose and it was remodeled into a forced-circulation compartment kiln and was equipped with temperature-control and humidity-control devices. A series of tests on shortleaf pine was made in this kiln; the results, when compared with the previous experiments, indicated a marked improvement in the quality of the stock both in B and Better and in the common grades. The time of drying, despite the higher relative humidities used, was perhaps a trifle less than that required in the natural-circulation kilns.

#### EXPERIMENTS ON LONGLEAF PINE

Since both the kiln-drying experiments just described had been made on shortleaf pine, it was deemed advisable, because of characteristic differences in the species, to make a distinct set of experiments on longleaf. This work was undertaken at a plant in Alabama in the spring of 1926. Some drying and degrade experiments made at the same plant two years earlier (1924) had brought out the fact that no real improvement in the operation of the existing kilns could be secured without more or less modification of the kilns themselves. The kilns, 82 feet long, were too short to work properly as natural-circulation progressive kilns under the existing distribution of heating surface and system of ventilation. Accordingly, after consideration of several possible methods of modifying them, including both natural and forced circulation, one kiln had been remodeled into an internal-fan compartment kiln and equipped with

automatic-temperature and humidity-control devices, and its successful operation had led to the later remodeling of seven others in the same way.

The 1926 experiments were of somewhat broader scope than the 1924 tests, in that stacking and stickering methods, storage subsequent to kiln drying, and machining problems were also included.

In addition to the general experiments conducted in cooperation with the Southern Pine Association, a considerable number of independent tests have also been made as opportunity offered.

### CAUSES OF DEGRADE

The grading rules define the defects that establish the grade into which a board will fall. Some of these defects, such as knots and pitch pockets, are natural, existing in the living tree; others, such as wane, occur in manufacturing; while still others, such as end and surface checks, are caused essentially by the drying process. Certain other defects, such as planer splits, are due partly to drying and partly to other causes.

The criterion of good drying is small seasoning degrade and stock having a moisture content suitable for the purpose for which it will be used. Further, the stock should be free from injurious internal stresses and its strength properties should be substantially unimpaired. Any workable means of improving drying practice, thus reducing degrade, returns an immediate profit to the manufacturer. In the practical side of experimental work in the drying of southern yellow pine the object has been principally to learn the nature, cause, and extent of drying defects as they appear in the degrade and the amount of degrade and also to determine to what degree such defects may be reduced. The means used for reducing degrade, fortunately, are the same as those required to obtain greater uniformity in moisture content.

### DEFECTS THAT APPEAR IN KILN DRYING

The defects chargeable to the drying process may be grouped under the five heads that follow:

#### CHECKS AND SPLITS

Checking and splitting are the principal causes of degrade in all grades, but are of particular importance in B and Better stock. These defects may appear either in the kiln, during drying, or at the planer. Checks and splits that develop during seasoning occur when the surface of the board dries faster than the interior and attempts to shrink before the interior is ready to shrink; as a result the surface fibers tear apart. Splits that develop at the planer come from cupping, twisting, casehardening, or brittleness caused by overdrying. They occur when the piece is flattened on the bed of the planer.

#### IMPERFECT KNOTS

Loose, checked, and broken knots are an important source of degrade in the common grades. As explained on page 13, the knot in shrinking tends to become smaller than the knot hole. Live

knots, if firmly grown into the surrounding wood structure, may only check, but encased knots will become loose if sufficient shrinkage occurs.

#### WARPING

Such defects as cup, crook, and twist are caused by variations in shrinkage within the board affected. Cupping is particularly serious, since cupped stock is likely to split when going through the planer. Crook is usually caused by unequal longitudinal shrinkage between the two edges of the board; it occurs principally in stock that has been cut from trees having compression wood. Page 10 presents more information on compression wood and its effects.

#### UNDERDRYING AND OVERDRYING

Stock that is underdry is very likely to shrink further, and consequently such a condition is objectionable, especially in upper-grade stock. Improper kiln operation and poor stacking on kiln cars are the most common factors responsible for this defective condition. Overdry stock is brittle, and brittleness contributes to checking and splitting. Such stock also may swell after planing, an undesirable condition in high-grade flooring and finish.

Operators ordinarily intend to dry upper-grade 4/4-inch lumber to a moisture content of from 7 to 10 per cent, and lower grade to a moisture content of from 12 to 18 per cent. When so dried the stock is commonly considered suitable for the use requirements of the respective grades. Underdry stock naturally has a moisture content above the high limit for its grade.

#### CASEHARDENING

Casehardening contributes materially to drying degrade, but it is usually associated with one of the other causes in such a manner as to make recognition of the real offender difficult for the uninitiated.

Casehardened lumber cups when resawn or when more is dressed off one side than off the other. (Pl. 2, A.) In southern yellow pine the condition becomes apparent when resawing any thick stock and when resawing stock for bevel siding. The pinching in of the grooves in flooring and other matched items is also evidence of casehardening. The most serious result of the internal stresses, particularly in cupped stock, is the weakening of the wood, which causes a larger percentage of boards to split in the planer than is the case in boards that are not casehardened.

#### METHOD OF GRADING

The grading in the drying and degrade experiments at commercial plants was done by an official inspector of the Southern Pine Association and the tallies were so kept that the recognized defects causing degrade could be segregated.

In some of the earlier experiments the stock was graded both green and dry. In the 1926 studies the stock was not graded at the green chains, but, after drying and machining, was graded and tallied at the dry chains on the basis of the grade that it had had when green, and was then charged with any change in grade that had devel-

oped during drying and manufacture. Only those defects that had been caused by drying or were related to drying were considered in this test; the grader was instructed to use his best judgment in establishing both green and final grades so that they would register the defects with which the study was concerned. Wane, imperfect manufacture, and pitch pockets, for instance, are not seasoning defects and therefore pieces containing such defects were tallied as of their original green grade unless the grade had been lowered by seasoning defects. Stock undergoing these tests was not ripped after kiln drying to raise grade but was run in the same widths in which it was dried. Where a trim would have raised the grade above the green grade, the piece was tallied as of its green grade and if trimmed because of a drying defect the trim was also charged against the piece. For a combination of drying defects resulting in degrade the cause of the degrade was charged to the most consistent defect or to the defect occurring most frequently.

Occasional pieces, for which the cause of degrade was questionable or could not be determined at a glance, were pulled from the chains and graded later.

Except for matched flooring, ceiling, and siding it is more or less immaterial, for a degrade investigation, whether the stock is run into a pattern or only surfaced four sides. For simplification and accuracy the stock examined was grouped under the grades B and Better, No. 1 Common, and No. 2 Common, thus avoiding the complication of intermediate grades.

It was intended that each size and grade should include enough material to be representative of that particular stock; a minimum of 2,000 board feet was desired and 4,000 to 5,000 feet was, usually obtained. In a few instances, however, there was not enough material available at the time the kiln trucks were being loaded to make up the minimum desired.

#### LOSS CAUSED BY INFERIOR KILN DRYING

Table 2 on page 40 shows briefly the cost of inferior kiln drying of southern yellow pine as determined by means of the experiments at commercial plants here reported. The lumber prices from which the losses were calculated are practically identical with the corresponding January, 1929, lumber prices; this statement applies also to the other prices used for this bulletin.

#### CONTROLLING KILN DEGRADE

In devising methods of control over the factors that cause kiln degrade it is necessary to divide the preparation of stock for the planer into three principal steps, so that the influence of each one on the ultimate degrade can be studied independently of the others. The lowest possible degrades are obtained only when each step follows the best known practice. The logical divisions follow:

Piling, including stickering, in loading the kiln trucks.

Drying conditions in the kiln: Temperature, humidity, and circulation.

Storage after kiln drying and before planing.

Numerous experiments have demonstrated that improvement in the practice of any one of these factors, independent of the others,



will definitely reduce drying degrade. If the stock can be properly conditioned by steaming before it leaves the kiln, however, storage after kiln drying is not necessary or even advantageous in preventing degrade; the stock may then be run direct from the kiln to the planer.

#### PILING

Certain kinds of defects, such as cup and twist, are a result of poor stacking, quite independent of whether the kiln-drying methods proper are good or poor. These defects increase the amount of checking, splitting, and torn grain, and the number of broken knots. Good stacking with plenty of stickers reduces crook, holds the stock flat, and is an important factor in the prevention of degrade regardless of other conditions in the kiln.

#### KILN OPERATION

Careful seasoning in kilns where drying conditions can be accurately controlled is probably the most important factor in holding kiln degrade to a minimum. Checks and splits during drying may thus be avoided and overdrying prevented, thereby reducing planer splitting and damage to knots. Relief of casehardening, uniformity of moisture content, and less pitch on the surface of the boards also play their part in producing stock in the best condition for manufacture and use.

#### CONDITIONING BEFORE MACHINING

Storage of rough stock after kiln drying and before planing has an effect similar to that obtained by conditioning in the dry kiln. Where kilns are not provided with means for steaming the stock before it is removed from the kiln, or are not of a design that permits such treatment, storage is beneficial, especially if the stock remains in the shed for periods upward of three weeks.

#### ECONOMIC LIMITATIONS

The limitations surrounding the kiln-drying practice at many southern pine mills are such that it may not be economically advisable to make all of the changes required for holding degrade to the absolute minimum. It is rare, however, that improvement in the practice of at least one of the three main factors is impossible. The advantages and the limitations of control over these independent factors will be considered separately, beginning with the design of the kiln and its effect on drying conditions.

### TYPES OF KILNS FOR SEASONING SOUTHERN YELLOW PINE

#### SMOKE AND FURNACE-HEATED KILNS

In the southern pine region approximately half of the cutting is done by small portable or semiportable mills for which it seems impracticable or unprofitable to install a steam kiln for the usual period of operation on any one site. A large part of the cut of these small mills is sold green or air seasoned, while some is collected in

concentration yards or is sold to large mills where kilns are available.

In the shortleaf pine areas, particularly in Arkansas, many of the small mills use smoke kilns. Such a kiln consists of a loosely built platform set on posts and about 8 feet or more off the ground, with boarding on three sides above and on three or four sides below it. Lumber is piled on slickers on the platform, sometimes flat and sometimes on edge, and a fire is built on the ground beneath it, the smoke passing upward through the lumber pile. The lumber, of course, is darkened by the smoke, but the discoloration is dressed off when the stock is planed.

This type of kiln permits the small operator to dry his stock more rapidly than he could by air seasoning. Rapid drying, among other desirable results, reduces the probability of blue-stain attack. Sometimes the material accumulates slowly and several days will elapse while the kiln is being loaded and before the fire is started. Blue stain is very likely to develop during this period and also during rainy weather, when it seems impractical to keep the fire burning.

The drying time for 1-inch southern yellow pine stock in a smoke kiln is variable, although it usually is three to four days. The degree of drying, as might be expected, is also variable; the drying is irregular, not only in different parts of the pile but sometimes even within the same board. At one time smoke-dried lumber was in popular demand, but within recent years, because of the higher standard of seasoning required by the buyers and the general improvement in the standard of seasoning in steam-heated kilns, smoke-dried stock has often been sold at a price considerably below that of stock from steam-heated kilns. The usual type of smoke kiln offers such slight opportunity for control of drying conditions that there is little hope for improvement in the seasoning process proper. Some improvement in the product, however, may be obtained by improving the stacking. Storage after drying will also help to equalize the moisture content, particularly in stock that has been dried to a relatively low moisture content.

The furnace kiln differs from the smoke kiln in that the fire is built in a fireplace or fire pot of metal or brick and is fed from the outside of the kiln. The fire pot and the smoke flues, which are looped around within the kiln below the lumber pile, act as radiators to heat the air. The smoke is exhausted through chimneys instead of passing through the lumber. The kiln building is a tight inclosure and when the fire is carefully tended a fair degree of temperature control is possible. Humidity control, however, is more difficult to obtain. Tight construction and dampered intake and exhaust flues offer an opportunity to retain some of the moisture evaporated from the lumber, but this method is usually inadequate. If steam is available it should be used in the same manner as when humidifying steam-heated kilns.

#### STEAM-HEATED KILNS

Steam is the medium most commonly used for heating dry kilns, because of the very numerous advantages it offers in comparison with other means. It is employed in all the types of kilns included in the following discussion.

Steam-heated dry kilns in the southern pine region may be separated into two groups, progressive and compartment. While it appears at first that the difference between progressive and compartment kilns is essentially that of the method of loading, actually there are also very important differences in design which, in turn, have quite an important bearing on the method of operation best suited to the stock being dried. These differences will be taken up in detail later.

Both progressive and compartment kilns may also be classified, in accordance with the principle of circulation employed, as (1) natural circulation, (2) forced circulation, which is sometimes called "mechanical circulation," and (3) combined natural circulation and forced circulation.

#### PROGRESSIVE KILNS

The progressive kiln holds a number of unit charges of lumber, which are in different stages of drying; each unit charge consists of about one-third or one-fourth the total capacity of the kiln. When a unit charge has dried and has been removed, a fresh one of green lumber is introduced into the opposite end of the kiln; this unit then passes by stages from the charge or green end to the discharge or dry end, eventually emerging as "dry" lumber. The design of this kiln intends that the drying conditions, as well as the movement of the unit charges, shall be progressive, the mild conditions obtaining at the green end and the most severe at the dry end.

#### COMPARTMENT KILNS

In compartment kilns a single charge occupies all of the loading space and drying conditions are intended to be uniform throughout the kiln at any given moment. The drying conditions are changed from time to time in conformity with the moisture condition of the stock or in accordance with a time schedule.

#### NATURAL CIRCULATION IN STEAM-HEATED KILNS

Natural circulation in steam-heated kilns is brought about by differences in temperature; the steam in the coils supplies heat and evaporation from the lumber consumes it. The heated air tends to rise from the coils and the air cooled by evaporation tends to sink. If the arrangement of the lumber and the heating coils is such as to facilitate this movement, a very definite circulation will exist as long as drying takes place.

Heat losses through doors, roofs, and outside walls produce local cooling effects, which add to the general air movement, but these effects vary more or less in accordance with the outside atmospheric conditions and in consequence are unreliable and are therefore more of a hazard than a benefit. Because the kiln is much hotter than the temperature of the air outside, there is a constant leakage of heated air from the upper part of the kiln and of cold air from the outside into its lower part. Vents, flues, or chimneys are provided to facilitate the escape of some of the air from the kiln because it carries with it the moisture evaporated from the wood. Fresh-air inlets may also be provided in the bottom of the kiln to

admit air to replace that escaping through the chimneys. If no fresh-air inlet is provided, replacement is dependent upon inleakage through cracks and crevices in the walls and around the doors.

The amount of air passing through the average natural-circulation kiln, entering the intake ducts and going out through the chimneys, has been calculated as less than 5 per cent of the air that is in motion in the kiln. Increasing the number and the size of the inlets and the exhaust flues for the purpose of increasing the air flow would have very little effect on circulation but would increase steam consumption. In natural-circulation kilns, therefore, the amount of air movement produced by passage of air through the kiln and out of the chimneys may be considered an unimportant part of the total. The whole purpose of exhausting air from the kiln is to carry away the evaporated moisture; the ideal condition would be reached if it were possible to control the chimneys and flues with dampers so regulating the flow that the moisture would be carried away only as fast as it evaporates, thus holding the humidity at the value required by the schedule.

The circulation through the piles of lumber represents the bulk of the moving air. Its natural direction is vertical, either upward or downward; it will move horizontally only to the extent that its natural direction is opposed. Such opposition may result from the manner of piling or from counter air currents.

#### NATURAL-CIRCULATION PROGRESSIVE KILNS

The characteristics of natural circulation in a southern pine progressive kiln are illustrated in Figure 6. Hot-air exhaust flues and cold-air intakes differ more or less in location according to the make of the kiln and, since their position has no important effect on the principal air movement, they are left out of this illustration. Because some means must be provided for the removal of evaporated moisture, however, both intake and exhaust flues are assumed to exist. The total kiln charge of 15 trucks comprises 3 unit charges of 5 trucks each, the charge at the green end representing stock loaded less than 1 day, the middle charge less than 2 days, and the dry-end charge less than 3 days; each charge is to be removed after 3 full days in the kiln. As the heat required for evaporation is extracted from the air surrounding the individual pieces of lumber, the air becomes cooler in proportion to the amount of moisture evaporated. Where evaporation is rapid and considerable cooling takes place, the air movement is downward through the lumber pile even when the heating coils are in the path of this movement. Even if the coils are in the path, the weight of the column of air above is great enough to counterbalance the influence of the heat added by them, and the air continues to pass downward through the coils in order to rise where it meets less resistance to an upward movement, as, for example, between the pile and the wall, or at the dry end of the kiln, where evaporation is less rapid.

Evaporation from the relatively wet lumber at the green end of a progressive kiln is very rapid, and consequently the air movement is downward. (Fig. 6.) The same direction of movement also exists in the middle charge but, since this stock has lost much of its moisture, evaporation is somewhat less rapid and the rate of movement is

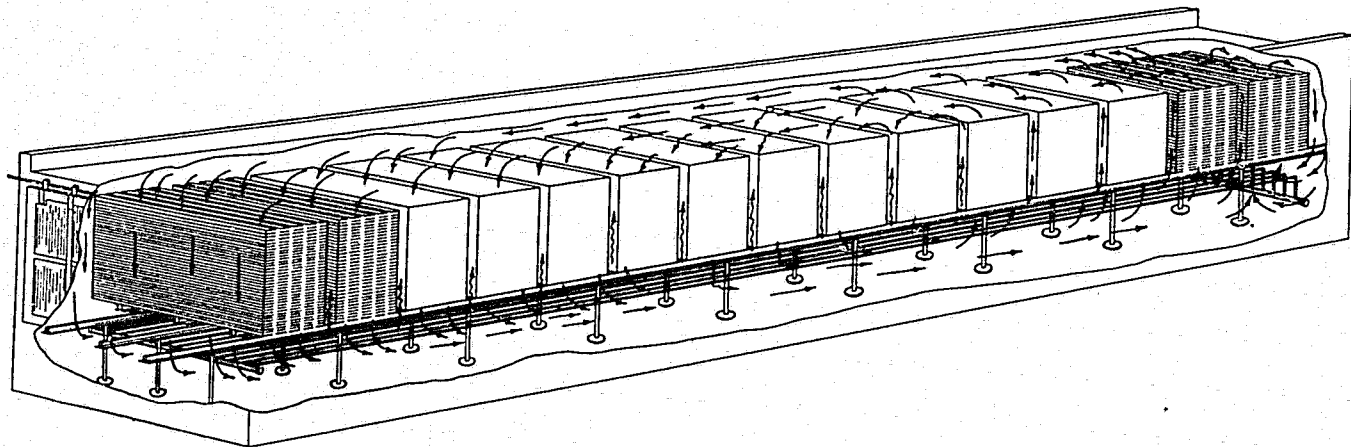

FIGURE 6.—A cross-piled natural-circulation progressive kiln in perspective. The lumber moves from left to right, whereas the main longitudinal air circulation above the rail level is in the reverse direction. In addition there are minor local currents of air up and down through the lumber, as indicated by the arrows; the wavy arrows indicate sluggish air movement. The cooling effect of each door produces local downward circulation at the extreme ends of the kiln. Since the principal movement of air in natural-circulation kilns is vertical, for both the progressive and the compartment types, the stickers do not oppose the main circulation with either end piling or cross piling

reduced proportionately. The charge in the dry end is nearly dry, little evaporation is taking place, and here circulation will be upward. It sometimes happens that stock passes through the first and the second day's positions and reaches the final position while still containing considerable moisture. In such cases the circulation has been found to be downward even at the dry end, until the stock became relatively dry. When this stock has dried sufficiently the air movement reverses, the air then flowing upward.

Ordinarily most of the air that descends in the first and the second position of the daily charge finds its way upward through the load in the third position, but some works up along the side walls or in any open spaces resulting from short lumber in the loads. The general movement is a cycle, downward at the green end to some point below the steam coils, along the kiln to the dry end, and then upward, returning along the ceiling to the green end.

Heat losses through the roof and the doors of a progressive kiln have some effect in modifying conditions locally. The principal effect of the roof loss is that it lowers the temperature of the air moving from the dry to the green end, a condition that is more or less beneficial. Cold drafts from the doors are rather objectionable, particularly at the dry end where such cold air, mixing with the hotter air returning from the green end, cools the portion it joins and consequently produces a lower temperature in any load it may pass through, thus interfering somewhat with drying conditions; these drafts usually affect the load nearest the door.

#### NATURAL-CIRCULATION COMPARTMENT KILNS

The characteristics of natural circulation in a southern pine compartment kiln are illustrated in Figures 7 and 8. Here again, as with progressive kilns, hot-air exhaust flues and cold-air intakes are left out of the drawing, but are assumed to exist. Figure 7 illustrates a kiln with cross piling and Figure 8 shows one with lengthwise piling.

The factors that create natural circulation, which are the heat supplied from the steam coils, the consumption of heat in evaporation, and heat losses through roof, walls, and doors, are the same in compartment as in progressive kilns. However, there is one important difference between the two types that affects the volume of air moved as a result of the cooling effect resulting from evaporation. Since this volume includes most of the air in motion it has an important effect on the rate of drying, an effect that is in favor of the progressive kiln. The greater the difference between the temperature of the ascending air and that of the descending air, the greater will be the velocity of movement. The difference in temperature is definitely limited by the drying schedule used, in that after the lumber is once warmed up to kiln temperatures the lowest possible temperature, as a result of evaporation, is the wet-bulb temperature. For example, following the initial conditions for warming the stock, a certain schedule (No. 107, p. 43) calls for a temperature of 190° F. and a relative humidity of 63 per cent. for which the wet-bulb temperature is 170°. (Fig. 9.<sup>11</sup>) In this temporary condition the lowest possible

<sup>11</sup> See footnote 4 on p. 2; refer to Table 1 in Bulletin 1130 (5).

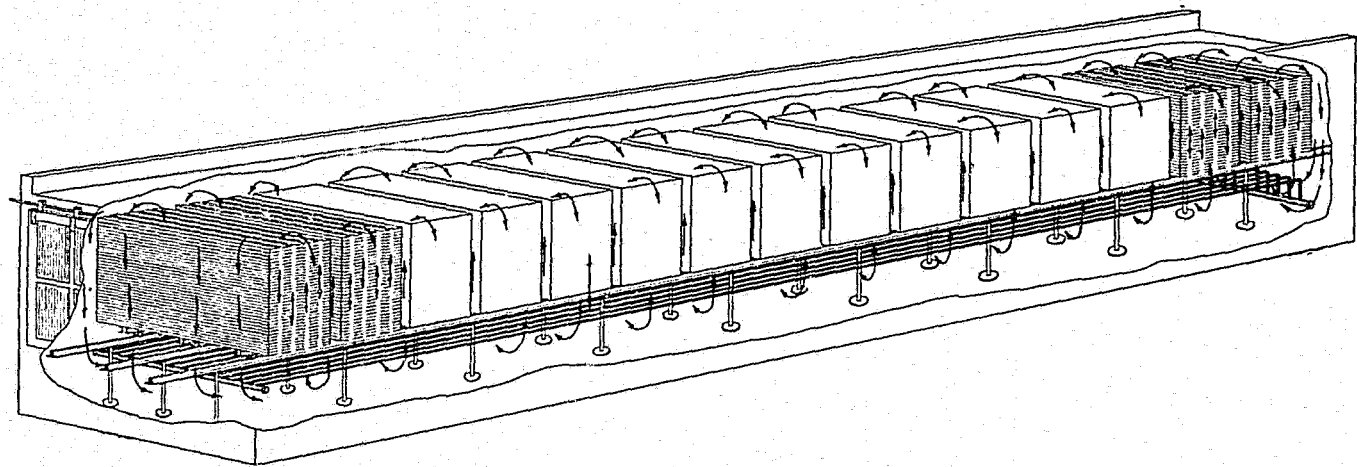

FIGURE 7.—A cross-piled natural-circulation compartment kiln in perspective. The arrows indicate the direction of the main circulation, which is vertical-lateral. During the early part of the run, when evaporation is rapid, the air movement is downward in the pile, through the heating coils, to the space at the side walls or to other unobstructed vertical channels, upward, and into the pile to repeat the cycle. During the final stage of drying, the heating coils, which are immediately below the lumber, overcome the circulatory effect of the evaporation, which has now become slow, and the main circulation then reverses, as shown by the double-headed arrows. Heat losses through the doors produce local downward circulation at the extreme ends of the kiln. Since the principal movement of air in natural-circulation kilns is vertical for both the progressive and the compartment types, the stickers do not oppose the main circulation with either end piling or cross piling.

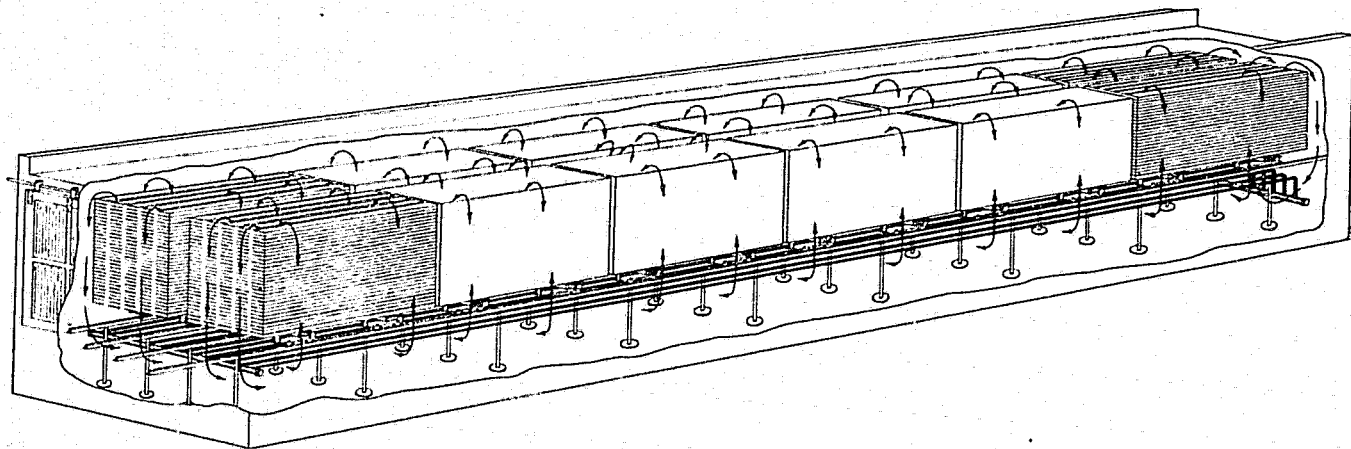

FIGURE 8.—An end-piled natural-circulation compartment kiln in perspective. The arrows indicate the direction of the main circulation, which is vertical-lateral. During the early part of the run, when evaporation is rapid, the air movement is downward in the pile, through the heating coils, to the space between piles and to that at the side walls or to other unobstructed vertical channels, upward, and into the pile to repeat the cycle. During the final stage of drying, the heating coils, which are immediately below the lumber, overcome the circulatory effect of the evaporation, which has now become slow, and the main circulation then reverses, as shown by the double-headed arrows. Heat losses through the doors produce local downward circulation at the extreme ends of the kiln. Since the principal movement of air in natural-circulation kilns is vertical, for both the progressive and the compartment types, the stickers do not oppose the main circulation with either end piling or cross piling



temperature as a result of evaporation would be about 170°. Under the established drying conditions that follow it would be nearer 175°, a matter of 15° difference between the highest and the lowest temperature in the pile. In a progressive kiln operating on the same schedule the temperatures would be about a maximum of 210° where the air enters the pile at the dry end and a minimum of 175° where it leaves the pile at the green end, a difference of 35° between the highest and the lowest. Obviously the air movement possible in the progressive kiln is far greater than that in the compartment; such an air move-

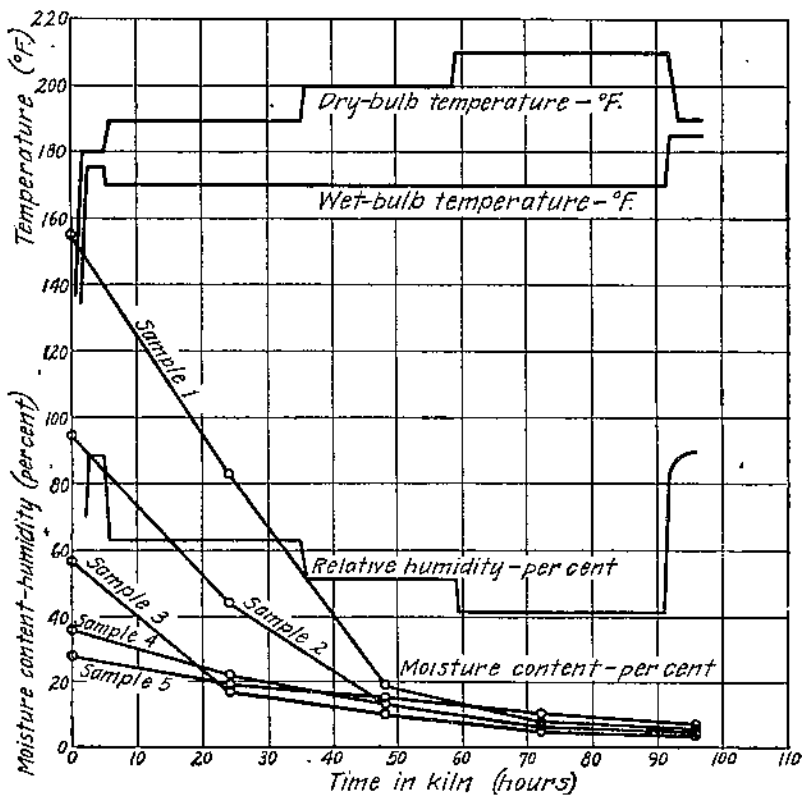

FIGURE 9.—The plotted record of a kiln run that followed Schedule 107 (p. 43) accurately. The lower graphs show the changes in the moisture-content values of representative kiln samples. They show also that the humidity specified in the schedule was high enough to reduce the drying rates of the rapidly drying pieces to values that agreed reasonably with the rates of the slow drying pieces, thus avoiding overdrying, in accordance with the purpose of the schedule.

ment is invariably found in the progressive kiln in spite of the longer travel necessary for the air to complete its cycle of movement. Hence at relatively high humidities, such as those during the early part of a run, the compartment kiln does not obtain the air velocity possible in a progressive kiln.

During the final stages of drying, when the schedule selected for illustration permits a temperature of 210° F. and a relative humidity of 41 per cent, which comes to a wet-bulb temperature of 170°, the compartment kiln is still at a disadvantage. By this time the stock

is comparatively dry and the evaporation is slower, so instead of cooling to 175° the air will seldom cool below 195°.

In an attempt to obtain an equal rate of drying, most southern pine natural-circulation compartment kilns are actually operated under schedules much more severe than those for progressive kilns. This practice is unwise, since the resulting conditions are likely to cause heavy degrade.

The direction of air movement in the cycle characteristic of compartment kilns is vertical-lateral. During the time when evaporation is rapid the movement is downward in the pile, through the heating coils, to the space at the side walls or to other unobstructed vertical channels, upward, and into the pile to repeat the cycle. During the final stage of drying the heating coils, which are immediately below the lumber, overcome the circulatory effect of the evaporation, which has now become slow. The circulation then reverses, the air moving upward from the coils into the pile, across to the space at the side walls or to similar openings, downward, and back to the coils.

Heat losses through the doors of a compartment kiln cause a downward movement of air at the ends of the kiln to the space below the rails, where the cold stream joins the regular lateral circulation below the end trucks. The effect is to lower the temperature materially, and consequently it is quite common to find the lumber in this space underdried when the rest of the charge is thoroughly dry. Heat losses through the side walls and the roof are relatively uniform along the kiln and do not necessarily interfere with the drying conditions if the heating surface provided is sufficient to offset the loss.

#### EFFECT OF HUMIDITY ON NATURAL CIRCULATION

It has been explained that the movement of air increases as the difference between the wet-bulb and the dry-bulb temperatures increases; that is, the lower the humidity, the better the circulation. Good drying practice requires that suitably high humidities be maintained throughout the drying period, particularly during the early stages of drying. If the proper humidity is maintained, it evidently will be at the expense of natural circulation. This fact, in turn, will result not only in slower drying but also in irregular drying unless the drying time is extended. In an experiment in a natural-circulation progressive kiln it was found that the drying period for No. 1 Common and Better stock was increased from 72 to 84 hours by changing from the low humidities previously employed by the operators to high ones. The degrade for the high-humidity drying, however, was only about one-fourth that for the low-humidity schedule.

In the common grades of knotty stock relatively high final humidities are required to keep degrade at a minimum, and natural circulation consequently is inadequate.

#### FORCED CIRCULATION IN STEAM-HEATED KILNS

Forced circulation in steam-heated kilns is commonly obtained by means of fans or steam jets, or both. When fans are used they may be either outside of the kiln in a special housing, connected to the kiln by supply and return ducts, or may be inside of it, usually in ducts or in housings intended to distribute the air according to the design of the kiln. When steam jets are used, high-pressure steam is

allowed to escape through small orifices in steam spray pipes, or through special nozzles. Here again the design of the kiln presumes that the circulation is to follow a certain path, either steadily or in cycles, and the spray pipes or nozzles are so located as to accomplish this purpose. Although steam-spray pipes offer one of the most simple expedients to augment natural circulation, the results are not always fully satisfactory.

Guidance of the moving air is required in kilns having circulation created entirely by mechanical means. Such guidance may involve baffles along the uninclosed air passages that always are necessary in every kiln. When baffles are used they must be located with considerable care in order that the flow of air may be uniform throughout each lumber pile. In both progressive and compartment kilns the air velocity must be restricted to a value that can be controlled as desired.

#### COMPARISON OF NATURAL AND OF FORCED CIRCULATION

From the foregoing discussion of circulation the matter of adequacy of air movement in a steam-heated kiln drying southern yellow pine lumber may be summarized as follows: Natural circulation is adequate in progressive kilns for the drying of upper-grade stock. It does not provide enough circulation in compartment kilns for any grade nor in progressive kilns for the lower grades. "Adequate circulation" in such a dry kiln may be defined as an air movement sufficient to permit the maintaining, throughout the drying period, of drying schedules closely approximating those given in this bulletin. Hence adequate circulation means reasonably uniform drying and the minimum period in the kiln that is consistent with minimum degrade. It follows, therefore, that inadequate circulation means a lack of uniformity of drying, a longer drying period, greater degrade, or a combination of the three. Common practice in such kilns is to use humidities lower than those recommended, in order that drying may be hastened and inequality in drying minimized; such practice largely disregards the degrade that results from the more severe drying conditions.

Natural-circulation kilns, both progressive and compartment, are still the type most common in the South. On the other hand, the modern trend of design of commercial kilns for southern yellow pine is to embody some more or less positive form of circulation created mechanically and intended to operate in conjunction with the natural circulation. Such design is planned to provide a sufficient amount of air movement during all stages of drying, quite independent of humidity. When steam is used to stimulate the circulation, however, it of course increases the humidity and, conversely, when it is used to control the humidity it should be released in such a manner that it will also stimulate the circulation.

### KILN OPERATION

#### FAULTS COMMON IN KILN OPERATION

##### LACK OF CONTROL OF DRYING CONDITIONS

Most of the older dry kilns used by southern pine manufacturers are of the natural-circulation progressive type, though there are a few scattered instances of compartment kilns. In most of the older

kilns the operation consists of loading, and then leaving the kiln to itself until the stock is dry and ready to unload. No particular attempt is made to control temperatures and humidities. In such cases the temperatures in progressive kilns are lowest at the charge end because of the rapid evaporation from the green lumber. As the lumber becomes drier and progresses toward the discharge end less evaporation takes place and the temperatures are higher. After loading, the temperature at the green end rises rapidly to about 150° F., but during the first 24 hours it seldom goes above 170° to 175°. There is usually from 20° to 40° difference between the temperatures at the two ends. Immediately after loading, the relative humidity is comparatively high at the green end, sometimes near 100 per cent, but a few hours after loading it is usually below 50 per cent at the green end and below 20 per cent at the dry end. If the relative humidity in the kiln were 100 per cent, no evaporation would take place, no change in temperature would come from that source, and consequently no circulation would follow. Conversely, the lower the humidity the greater the possible differences in temperatures and therefore the greater the air movement.

#### EXCESSIVELY LOW HUMIDITY

The humidity in pine kilns not provided with steam sprays or some other means of humidifying is ordinarily very low. The only moisture available to raise the humidity is that evaporated from the lumber, and it can escape from the kiln in the form of vapor through ventilators, chimneys, and crevices, leaving the humidity in the kiln a natural balance between the rate of evaporation and the rate of escape.

While a low humidity is useful in producing natural circulation, it is the condition that causes checking, overdrying, casehardening, and damage to knots. On the other hand, if the humidity is raised either by closing dampers or by use of steam sprays that do not create circulation, the drying time in the kiln lengthens and underdry stock is often found. Less degrade, however, is likely to occur with high humidity than with low, although kiln operators usually follow the low-humidity method of operation.

The following example is an instance observed in a low-humidity progressive kiln in which a charge of 4/4-inch No. 1 Common and Better longleaf pine was dried in four days. Immediately before the placing of fresh charges the temperatures at the green end were nearly 200° F. and the relative humidities sometimes were as low as 20 per cent, while the temperatures and relative humidities at the dry end were about 220° and 15 per cent, respectively. After charging, and following the initial drop, the green-end temperature would rise in a few hours to 170° and the relative humidity would be about 35 per cent, and at the dry end these conditions would be 185° and 25 per cent, respectively. The following figures represent the rate of drying as indicated by six samples located in the outside tiers of the trucks: Moisture content, when loaded into the kiln, 74.6 per cent; after the first day, 34.8 per cent; after the second day, 7.8 per cent; after the third day, 5.0 per cent; after the fourth day, at the time of unloading, 2.7 per cent. The samples naturally represent the drying rate of the outer portion of the truck loads, some of the

stock in the center of the piles drying somewhat more slowly. The figures show that for the stock represented 55 per cent of the total moisture lost was evaporated the first day and 93 per cent was evaporated by the end of the second day. These conditions are not at all exceptional but are actually typical at the majority of southern-pine plants where such kiln equipment is in use. The degrade observed in stock dried in this kiln may therefore be considered an example of the degrade occurring in plants having similar equipment.

#### REPRESENTATIVE DEGRADE LOSSES

Table 2 presents data covering representative degrade in stock dried in the kilns just described and run direct from the kilns to the planers. The stock had been flat piled in standard 16-foot trucks with six stickers to the course. If more stickers had been used the degrade would have been lower for reasons that will be given later. Even with better stickering, however, the harsh, severe conditions early in the drying process and overdrying in the final period would still have produced casehardening and brittleness. These in turn would have caused planer splitting and broken and loose knots comparable with the degrade losses referred to later in Table 9 (p. 56).

TABLE 2.—*Depreciation in value per thousand board feet of longleaf pine dried during 1924 in a natural-circulation progressive kiln with six stickers per course and run direct from the kiln to the planer*

Size of stock	Grade	Stock on grade	Stock degraded for—				Loss per 1,000 board feet <sup>1</sup>
			Splits	Trim	Knots	Miscellaneous	
<i>Inches</i>		<i>Per cent</i>	<i>Per cent</i>	<i>Per cent</i>	<i>Per cent</i>	<i>Per cent</i>	
1 by 6, 1 by 8, 2 by 10, 1 by 12..	B and Better.....	85.20	10.92	3.45		0.43	\$5.61
1 by 6, 1 by 8, 2 by 10, 1 by 12..	No. 1 Common.....	66.40	20.46	3.15	10.05		8.74
1 by 6, 1 by 8, 1 by 10.....	No. 2 Common.....	54.60	24.10	.60	20.70		1.47

<sup>1</sup> Based on lumber prices substantially the same as those for January, 1929.

#### RESULT OF IMPROVING DRYING CONDITIONS

After the degrade tests just described, these progressive kilns were remodeled into compartment kilns equipped with automatic temperature and humidity control devices and a forced-circulation system was installed. The results of degrade tests on stock dried in accordance with Schedules 107 and 108 (pp. 43 and 44) and run direct from the kiln to the planer are shown in Table 3. The improvement over the results obtained before the kilns were remodeled (Table 2) is marked. This improvement may be attributed to the milder conditions during the early period of drying and the prevention of overdry stock by the use of more suitable final humidities. The B and Better and the No. 1 Common stock were in the same kiln charge. Their values of moisture content, averaged from eight samples, were as follows: When loaded into the kiln, 81.2 per cent; after the first day, 58.8 per cent; after the second day, 28.6 per cent; after the third day, 11.8 per cent; and after the fourth day, 6.8 per cent. The No. 2 Common stock was dried separately.

TABLE 3.—*Depreciation in value per thousand board feet of longleaf pine dried in a forced-circulation compartment kiln in accordance with Schedules 107 and 108, after piling with stickers 2 feet apart, and run direct from the kiln to the planer*

Size of stock	Grade	Stock on grade	Stock degraded for—			Loss per 1,000 board feet <sup>1</sup>
			Splits	Trims	Knots	
<i>Inches</i>		<i>Per cent</i>	<i>Per cent</i>	<i>Per cent</i>	<i>Per cent</i>	
1 by 8, 1 by 8, 1 by 10.....	B and Better.....	99.43		0.57		\$0.36
1 by 6, 1 by 8, 1 by 10.....	No. 1 Common.....	97.65	1.82	.73		.72
1 by 6, 1 by 8, 1 by 10.....	No. 2 Common.....	94.79	1.86	.25	3.10	.88

<sup>1</sup> Based on lumber prices substantially the same as those for January, 1920.

A comparison of Tables 2 and 3 brings out the advantage resulting from accurate control of temperature and humidity, and positive and ample circulation. In many instances under observation steam sprays have been used to increase the circulation and at the same time to control the humidity in progressive kilns. In one such instance, after a careful study of the circulation distribution and of temperature and humidity throughout the kiln, a steam spray pipe was installed below the flat heating coils, about 35 feet from the dry end, with the sprays pointing toward the dry end. The steam supply to the spray was operated by the thermostat that controlled the humidity. Another thermostat controlled the temperature. A charge of 1 by 10 inch B and Better shortleaf pine in this kiln was degraded \$2.09 a thousand board feet because of seasoning defects, while the same size and grade in an adjacent kiln, one without steam sprays but under temperature control, was degraded \$3.66, which is about 75 per cent more. The stock in both cases was run through the planer 24 hours after leaving the kiln.

Of the two examples just given, one shows the increase in value of product that can be obtained through very accurate control of temperature and humidity and with ample circulation, and the other shows the corresponding increase secured through a much less positive form of temperature and humidity control and augmented natural circulation. Considering only economic matters, it would be futile to attempt to define the optimum degree of control of kiln conditions. It is clear, however, that any appreciable improvement in the control of these important seasoning factors will reduce seasoning degrade.

### DRYING SCHEDULES

#### SELECTING DRYING CONDITIONS TO MINIMIZE SHRINKAGE

Substantially all the seasoning defects that affect southern yellow pine are caused directly by or result from unequal shrinkage within the piece affected; blue stain and pitch are the important exceptions. Hence the drying schedule should be arranged so that unequal shrinkage will be minimized as far as possible. It has already been pointed out that shrinkage begins at the fiber-saturation point, which for southern yellow pine is estimated at about 25 per cent moisture content, and that the surface of the piece reaches this point very quickly after drying starts. The interior of the piece, however, does

not reach this point for a comparatively long time. Since green southern yellow pine lumber will normally shrink approximately 12 per cent in volume when dried completely, the potential capacity for unequal shrinkage between surface and interior during kiln drying is considerable.

Shrinkage in a piece of wood is for all practical purposes proportional to the amount of moisture lost below the fiber-saturation point. (Figs. 4 and 5 and p. 10.) For example, when a piece or any portion of a piece of southern yellow pine has reached 15 per cent moisture content approximately  $\frac{25-15}{25} = 10/25$  or two-fifths of the total shrinkage normally possible has occurred, and when it reaches 5 per cent moisture content the shrinkage is four-fifths of the total. Consequently the first step in establishing a drying schedule for green lumber is to select an initial humidity that will hold the moisture content at the surface of the lumber close to the fiber-saturation point, so that surface shrinkage will be temporarily retarded while evaporation may be at its highest permissible rate. On the other hand, in order to secure a flow to the surface of an amount of moisture sufficient to make a high rate of evaporation possible the surface must be below the fiber-saturation point far enough to cause transfusion of the moisture from the interior to it (p. 4). Then as the interior passes below the fiber-saturation point and continues to dry the kiln humidity is lowered by stages, so that the surface will be enough drier than the interior to permit drying but not enough to allow much difference in shrinkage.

#### DRYING CONDITIONS FOR KNOTTY STOCK

Clear, straight-grained stock when handled as just outlined may be dried to a very low moisture content practically without degrade. As explained on page 13, however, knots do not shrink with the wood surrounding them. Consequently knotty stock should not be dried to as low a moisture content as straight-grained, upper-grade material; since shrinkage is substantially in direct proportion to the drop in moisture content below the fiber-saturation point, the lower the moisture content the more probable will be damage to the knots. Further, the purposes for which knotty grades are used are ordinarily less exacting as to moisture content than those of the upper grades, and accordingly a moisture content equivalent to a well air-dried condition is generally considered quite satisfactory. The schedules made up for the knotty grades, therefore, are intended to prevent every possibility of overdrying, doing it through the use of relatively high humidities at all periods of drying, including the minimum humidity of the final period.

#### CRITICAL TEMPERATURE

All woods are more sensitive to temperature when green than when dry. A combination of heat and moisture at a temperature sufficiently high, continued over a considerable period, weakens the wood structure so much that it will yield to shrinkage stresses in the final stages of drying, thus making the occurrence of honeycombing and collapse very likely. The lowest temperature that will permit such a result is called the "critical temperature." For green mate-

rial the critical temperature varies widely among species, generally being lower for hardwoods than for softwoods. As the stock becomes drier and drier the critical temperature for a given species becomes higher and higher. Thoroughly kiln-dried stock of any species can withstand a very high kiln temperature without the development of degrade. Drying schedules commonly recognize the critical temperature of the species concerned; the initial temperatures for green or semigreen stock are kept below the point where injury is likely to occur, and as the drying progresses the temperatures are increased. Furthermore, as stock increases in thickness the initial drying temperatures are lowered.

**KILN SCHEDULES FOR SOUTHERN YELLOW PINE**

In comparison with most species the critical temperature of southern yellow pine is quite high, permitting the use of relatively high initial kiln temperatures. The temperatures given in the following schedules are considered the most severe to which any part of the kiln charge should be subjected. These temperatures, together with the other conditions specified, are intended to dry the charge to an average moisture content of approximately 7 per cent for No. 1 Common and Better stock and approximately 10 per cent for lower-grade stock. The schedules, applying to the stock separations most common at southern pine mills, are for operation on a flat time basis and are intended for use with forced-circulation compartment kilns. (Tables 4 to 8, inclusive.) For natural-circulation compartment kilns the same dry-bulb temperature may be used, but the relative humidities must be about 10 per cent lower than the values given, since otherwise the period required for drying will be excessive.

**TABLE 4.**—*Kiln-drying Schedule 106 for southern yellow pine, intended primarily for fast-circulation compartment kilns*

[For 1 by 3 inch and 1 by 4 inch No. 2 Common and Better flooring and partition stock]

Time in kiln after which changes should be made	Dry-bulb temperature	Wet-bulb temperature	Relative humidity
<i>Hours</i>	<i>° F.</i>	<i>° F.</i>	<i>Per cent</i>
0	175	170	80
5	190	170	83
35	200	180	39
67	190	182	84
72		End of run	

**TABLE 5.**—*Kiln-drying Schedule 107 for southern yellow pine, intended primarily for fast-circulation compartment kilns*

[For 1 by 6 inch and wider No. 1 Common and Better lumber]

Time in kiln after which changes should be made	Dry-bulb temperature	Wet-bulb temperature	Relative humidity
<i>Hours</i>	<i>° F.</i>	<i>° F.</i>	<i>Per cent</i>
0	180	175	80
5	190	170	83
35	200	170	51
50	210	170	41
91	190	182	84
96		End of run	



TABLE 6.—*Kiln-drying Schedule 108 for southern yellow pine, intended primarily for fast-circulation compartment kilns*

[For 1 by 6 inch and wider No. 2 Common lumber]

Time in kiln after which changes should be made	Dry-bulb temperature	Wet-bulb temperature	Relative humidity
<i>Hours</i>	<i>° F.</i>	<i>° F.</i>	<i>Per cent</i>
0	175	170	89
5	190	170	63
35	200	170	51
67	190	182	84
72		End of run	

† For stock containing very large knots use a wet-bulb temperature of 177° F.

TABLE 7.—*Kiln-drying Schedule 109 for southern yellow pine, intended primarily for fast-circulation compartment kilns*

[For all widths of 5/4-inch and 3/4-inch finish stock]

Time in kiln after which changes should be made	Dry-bulb temperature	Wet-bulb temperature	Relative humidity
<i>Hours</i>	<i>° F.</i>	<i>° F.</i>	<i>Per cent</i>
0	175	170	89
5	180	170	79
10	190	170	63
35	200	170	51
85	200	180	30
115	190	182	84
120		End of run	

TABLE 8.—*Kiln-drying Schedule 110 for southern yellow pine, intended primarily for fast-circulation compartment kilns*

[For all widths of 3/4-inch finish stock]

Time in kiln after which changes should be made	Dry-bulb temperature	Wet-bulb temperature	Relative humidity
<i>Hours</i>	<i>° F.</i>	<i>° F.</i>	<i>Per cent</i>
0	175	170	89
5	180	170	79
10	190	170	63
50	200	170	51
108	200	180	29
138	190	182	84
144		End of run	

In progressive kilns, on the other hand, temperature and humidity conditions are more a matter of location in the kiln and less one of intentional change at stated intervals. Temperature control is usually limited to one end of the kiln, most frequently the dry end. In it both temperature and humidity may be maintained quite constant but at the green end the temperatures vary more or less, being lowest immediately after loading and rising gradually as the stock becomes drier. Each operator of a progressive kiln will have to

work out compromise schedules that meet the conditions in his particular kiln. Probably the most satisfactory way to do this will be to control the dry end at the maximum temperature and the minimum humidity given in the proper schedule for compartment kilns. For example, to apply Schedule 107 to a progressive kiln, the dry-bulb temperature at the dry end would be 210° F., the wet-bulb 170°, and the relative humidity 41 per cent. The temperature at the green end would be the natural difference between the two ends and consequently it is very unlikely that this temperature would exceed 190° during the first 24 hours. The final 5-hour conditioning treatment specified in the schedules, of course, is impracticable in natural-circulation progressive kilns.

The time required for drying varies somewhat with the class of stock. The time given in the schedules is an average minimum period suitable for normal virgin-growth longleaf or shortleaf stock. Many operators will find it necessary to keep the stock in the kiln for 6 to 12 hours longer than the periods given. Second-growth shortleaf pine in the longleaf areas, and oldfield pine<sup>12</sup> in particular, is likely to require 25 per cent more time in the kiln, and the same is true of rapid-growth and dense-growth longleaf. When additional time is needed, the final drying period, which immediately precedes the conditioning treatment, may be extended as necessary.

#### FINAL CONDITIONING TREATMENT

The object of the final high-humidity conditioning treatment specified in the drying schedules is to relieve casehardening and to make the moisture content of the stock more nearly uniform; how this is accomplished will be described later. It is customary in conditioning treatments, especially with hardwoods, to employ temperatures 15° F. or more above the maximum drying temperatures in the schedule. The same method would be advocated for southern yellow pine if it were practicable. In the average kiln, however, it is difficult to maintain a wet-bulb temperature much above 180° without a tremendous steam consumption. On the other hand, it is equally difficult to cool the charge quickly from 200° or 210° to much less than 190°, because of the large amount of heat in the stock and in the kiln walls. To secure the comparatively small difference between dry-bulb and wet-bulb temperatures desired for such conditioning, therefore, in the preceding schedules each temperature is shifted a little way toward the other, thus accomplishing the purpose intended with a reasonable expenditure of steam and of time.

#### STOCK SEPARATION TO HASTEN SEASONING

If a kiln charge includes both fast-drying and slow-drying stock, it is the slow-drying material that determines the time required in the kiln. Results better than those possible with a mixed charge, better both in respect to quality of drying and in utilization of kiln space, can be secured through intelligent separation of stock. Ordinarily, sapwood in normal-growth southern yellow pine will require about 12 hours longer in the kiln than heartwood because it

<sup>12</sup> See footnote 8 on p. 15.

contains more moisture to be evaporated. Again, the No. 2 Common grades require less time than the upper grades because they are not dried to so low a moisture content. Further, some southern pine plants, which receive considerable quantities of red heart,<sup>13</sup> find that it can be dried in 30 to 36 hours less time than upper-grade stock. Considering the preceding factors, the stock separations should be about as follows: No. 1 Common and Better sapwood, No. 1 Common and Better heartwood, No. 2 Common and lower stock, and red heart. Further separations for thickness and for the characteristic differences between some kinds of longleaf and of oldfield<sup>14</sup> pine should be made as required.

## MOISTURE-CONTENT DETERMINATION

### OVEN-DRY METHOD

One of the primary requirements of successful drying is a means for the accurate determination of the moisture content of lumber. The customary method for such determination is to cross cut the piece to be tested at least 2 feet from one end, to avoid the effect of end drying, and then again about three-quarters of an inch from the first cut, thereby obtaining a cross section as wide and as thick as the original stock and three-quarters of an inch along the grain. All loose splinters are then removed from the section and it is weighed immediately on a sensitive scale. After recording the weight, which is called the original weight, the section is placed in a drying oven maintained at a constant temperature of about 212° F., and is left there until it has attained a practically constant weight, which will be in from 8 to 12 hours for kiln-dried southern yellow pine. It is then reweighed, to obtain the oven-dry weight. The difference between the original and the oven-dry weights represents the weight of the moisture originally in the section. The oven-dry weight represents the weight of actual wood substance with all water removed. The percentage of moisture content may now be determined by dividing the difference between the original and the oven-dry weights by the latter and multiplying the result by 100. The formula is:

$$\text{Moisture content based on oven-dry weight} = \frac{\text{Original weight} - \text{oven-dry weight}}{\text{Oven-dry weight}} \times 100.$$

As an example, if the original weight is 150 grams and the final weight is 90 grams, a difference of 60 grams, the moisture percentage will be  $\frac{60 \text{ grams}}{90 \text{ grams}} \times 100 = 66.7$  per cent.

Although any system of weights may be used, the most common is the metric, the unit weight of which is the gram; fractions of a gram are expressed in decimals. Any suitable balance may be used. One of the most popular among kiln operators is a multiple-beam type; this balance has a pan suspended from the main beam, and each beam is provided with a sliding weight. It has a normal capacity of 111 grams, with an auxiliary loose weight that nearly

<sup>13</sup> See footnote 9 on p. 15.

<sup>14</sup> See footnote 8 on p. 15.

doubles this capacity. With ordinary metal bearings, the sensitivity of this balance is about 0.05 of a gram, and with agate bearings it is sensitive to about 0.02 of a gram. Balances can be obtained from most dry-kiln manufacturers and from dealers in scientific instruments.

#### INSTANTANEOUS METHODS

Since several hours are required to make a moisture determination by the oven-dry method<sup>16</sup> a quicker means for determining when the charge is ready to leave the kiln is desirable for a rapid-drying stock like southern yellow pine. The length of time that the stock has been in the kiln may be taken as an indication of when to begin making definite tests, but should not be considered proof that the lumber is suitably dry, since the drying period varies with many factors. The moisture content of a fresh charge may be either higher or lower than usual, the kiln may have been shut down for a few hours, the temperature in the kiln may have been below normal, chilled stock loaded on a cold winter day may take from 6 to 12 hours longer to dry than stock loaded on a moderately warm day, and sometimes an unusually large amount of sapwood is present. These and similar factors may either increase or decrease the time in the kiln, thus making a definite test imperative.

Some experienced kiln operators can test stock for dryness by cutting into the stock with a sharp knife, obtaining a splinter from the board and snapping it much the same as breaking a match stick. If the piece breaks freely and sharply it is dry, but if the piece appears tough and does not break apart readily it is still green. This knife test is usually applied to a number of sapwood boards scattered over the face of the pile and the examiner often judges as much by the way the knife cuts the stock as by the action of the splinter.

When southern yellow pine becomes overdry a strong, pungent odor escapes from the kiln. A few pieces in a kiln charge always dry more rapidly than the rest; for instance, a charge dried to an average moisture content of 5 or 6 per cent will contain some pieces of only 2 per cent. The 2 per cent pieces are overdried; their brittleness is increased, and something in the wood, possibly the oleo-resin, evaporates, causing the pungent odor mentioned. Some operators become skillful in detecting an odor that precedes the one from overdry stock, and pull the load on this indication.

#### LIMITATIONS OF THE INSTANTANEOUS METHODS

Kiln runs should be checked frequently with a positive moisture determination, although termination of the run need not always be delayed for the outcome of the determination. Apparatus for making such determinations quickly are being developed; at present, however, the only positive method is the oven-dry. An operator skillful with the knife or other instantaneous test can become skillful and can remain so only through constant checking of his rule-of-thumb method. Further, the number of orders for which a moisture content is specified by the buyer is constantly increasing. The term "kiln dried" does not in itself determine how dry the stock may

<sup>16</sup> See footnote 4 on p. 2.

be nor does the knife test, the time in the kiln, or the odor. Only the equivalent of an oven-dry test will do that.

#### VARIATION IN MOISTURE CONTENT THROUGHOUT THE KILN CHARGE

At the time of unloading the kiln there is usually a rather wide difference in moisture content between the driest and the greenest pieces. The higher the average moisture content of the kiln charge the wider this difference is likely to be. It is less in stock dried in kilns having forced or augmented circulation and humidity control than in kilns depending upon natural circulation, with or without humidity control.

Tests have shown, where the average moisture content at the kiln door in 4/4-inch stock is about 8 per cent, that 90 per cent of the stock is below 12 per cent moisture content. In the remaining 10 per cent of the stock individual pieces containing between 20 and 30 per cent are sometimes found, although where good kiln control exists the upper limit ordinarily is below 18 per cent. Consequently tests on one or two boards will not be indicative of the true range of dryness of the charge; it is better to make several tests, 10 or more, when a fair degree of accuracy is desired.

The lowest moisture content in a truck load of stock is usually found in the outer layers of the pile and in the upper half of the load; the high values occur in the middle of the load and in the lower half. Further, there are differences in the stock itself, that from certain logs drying more slowly than the stock from others; this fact frequently accounts for lack of uniformity in the drying of adjacent boards. Pitchy stock, for instance, dries much more slowly than stock free from pitch. A piece of 4/4-inch stock showing heartwood full of pitch in the center of the cross section and pitch-free sapwood on the outside was found to contain 31 per cent moisture in the heartwood and 109 per cent in the sapwood before it entered the kiln. When the load was removed from the kiln this piece was again tested; the heartwood was found to contain about 17 per cent and the sapwood only 8.4 per cent moisture.

#### EFFECT OF THE DRYING SCHEDULE ON THE EXUDATION OF PITCH

Injuries to the growing southern yellow pine tree will cause pitch to accumulate in the surrounding wood fibers, and large injuries, such as turpentineing, sometimes cause pitch deposits that permeate the wood for a considerable distance above the wound. This pitchy material becomes partially fluid when subjected to the temperatures usual in the kiln and moves to the surfaces of the pieces. The lighter oils will then evaporate and the residue will remain on the surfaces as rosin.

Degrade from pitch in southern yellow pine is most common where the stock is overdried and particularly where temperatures in excess of 220° F. are used. The lower the average moisture content of a kiln-dried piece the greater the amount of pitch visible. Stock dried under schedules that prevent overdrying, by using relative humidities of not less than 40 per cent and temperatures not

over 220°, has fewer pitchy pieces than stock dried where these conditions are exceeded. Where the moisture content of the stock is 5 per cent or more there is less pitch exudation than in stock ranging from 2 to 4 per cent. Apparently the resinous deposit does not move through the wood readily until most of the water has been evaporated.

#### COST OF SHUTTING DOWN THE KILN

At many plants the steam supply to the kiln is shut off from Saturday evening to Monday morning in order to conserve fuel. This may be done because of lack of storage space for fuel or because all surplus fuel is sold. Whatever the reason, the practice is bad, both for the lumber in the kiln and for the kiln structure. It is particularly bad practice in natural-circulation progressive kilns because of the manner in which it breaks up the continuity of the drying operation. Some tests were made in a battery of such kilns, the stock under observation being 4/4-inch No. 1 Common and Better longleaf pine drying under a 3-day schedule through the kiln. The degrade in stock unloaded Monday, Tuesday, and Wednesday was about double that of stock unloaded Thursday, Friday, and Saturday.

When the steam supply was cut off, on a Saturday, the temperature in the kilns dropped slowly; it was 24 hours before the temperature at the dry end dropped from 220° to 150° F. and 30 hours before it dropped to 120°, because of the heat stored in the walls and in the lumber. Such circulation as existed was crosswise instead of lengthwise because the walls were the principal source of heat. The humidity, on the other hand, dropped very rapidly throughout the kiln, particularly at the green end. Hence a considerable amount of drying, especially at the green end, took place while the steam was cut off. Late Sunday night, when the steam was turned on again, the stock in the green end had become so dry that the evaporation was no longer enough faster than at the dry end to reestablish the longitudinal circulation definitely and consequently the kiln operated temporarily as a compartment kiln. On Monday morning, the charge at the dry end was unloaded and a fresh load of green stock was placed in the kiln, after which the proper circulation reestablished itself. All of the stock in the kiln during the time the steam was cut off was overdried and accordingly sustained more kiln damage than the stock dried by continuous operation. A rough but conservative estimate of the degrade resulting from the Sunday-closing practice showed a loss of more than \$450 in the value of the stock contained in eight kilns; to-day the loss would be greater.

The Sunday-closing practice also causes very rapid deterioration of the structure and the heating system. The alternate expansion and contraction in the brick walls of the kilns examined had produced great cracks, and the walls were out of line. Repairing, done presumably when parts of the wall had been found unsafe, was evident. The reinforced concrete roof was cracked and was slowly disintegrating at the cracks. The heating coils were in constant need of attention because of the effects of continued expansion and contraction. When it is necessary that the steam supply be cut off

from a kiln, every effort should be made to maintain both the temperature and the humidity until the steam is again turned on. The dampers, both inlet and outlet, should be closed and if it is available a small amount of steam should be released from the sprays to retain the humidity.

### STEAM CONSUMPTION

A tremendous amount of moisture escapes from the kilns every hour in the form of vapor. This vapor includes both the evaporated moisture and any steam used for humidification. The evaporated moisture alone averages approximately 25 pounds an hour for each thousand feet of ordinary lumber in the kiln, which is 1,312 pounds per hour for a 105-foot kiln holding 15 trucks of 3,500 board feet each. During some tests in a forced-circulation kiln on 4/4-inch No. 1 Common and Better longleaf pine the steam consumption averaged 2.76 pounds per pound of water evaporated, about one-half of which was used in maintaining humidity. For No. 2 Common stock, which had a faster average drying rate because of its shorter time in the kiln, the steam consumption was 2.16 pounds per pound of water evaporated. In natural-circulation kilns without humidity control, steam consumption is nearer 2 pounds per pound of evaporated water for No. 1 Common and Better and somewhat less for No. 2 Common stock. If kilns could be made reasonably vapor tight the amount of steam required could be reduced, particularly that required for controlling the humidity; in fact, if the kiln were practically vapor tight enough of the evaporated moisture could be retained to maintain the desired humidity, and the excess would then be allowed to escape through ventilators.

A change in the outside temperature has some effect on the steam consumption in dry kilns. A sharp drop, like that which at times occurs during a thundershower, shows an appreciable increase in such consumption. The peak load in progressive kilns occurs immediately after the kiln has been freshly charged and gradually decreases as the drying progresses. The same is true of compartment kilns, with smaller peaks occurring each time the temperatures are stepped up. In a natural-circulation progressive kiln under test, the average steam consumption was 1,091 pounds per hour; the peak load, which occurred immediately after loading, was 1,720 pounds per hour, and the minimum was 930 pounds per hour, just before unloading.

The amount of condensation per square foot of radiating surface is largely a matter of circulation. In adjacent kilns, one natural circulation and the other forced circulation, it was found that 1.08 pounds of steam could be condensed per square foot of radiating surface per hour in the forced-circulation kiln against 0.39 pound in the natural-circulation one. Where the efficiency of the heating coils is increased by good circulation, the amount of heating surface can be reduced proportionally.

### TEMPERATURE-CONTROL DEVICES

#### CONTROL EQUIPMENT IN THE STEAM LINES

The desirability of controlling temperature and humidity has been discussed elsewhere. (Pp. 38 to 41.) The usual methods of controlling humidity require that the temperature also be controlled

within reasonably close limits. The high temperatures used for drying southern yellow pine require high-pressure steam, exhaust steam not being hot enough to maintain the maximum temperature. Usually the steam supply is taken direct from the boilers to the kiln but, since the boiler pressure may vary widely because of the intermittent peak loads of the engines and other steam-operated machinery, a pressure regulator should be installed on the steam main to the kilns, preferably at or near the kilns. This pressure regulator should be set to provide from 80 to 100 pounds pressure in the steam main. The steam supply line to the coils in each kiln is provided with a globe or a gate valve by which the entire steam supply to each kiln may be turned on or cut off. Many kilns are provided with multiple coils, in which event each coil should be provided with an individual valve on its particular supply line, in addition to the main valves. All valves should be outside of the kiln in an accessible position, preferably in an operating pit below the tracks on the kiln platform.

#### MANUAL CONTROL

In the older types of kilns, the only control of temperature is through the hand-operated steam-supply valve on each kiln. Hand control in high-temperature kilns can hardly be expected to function within a 15° F. temperature fluctuation, and the variation is frequently 20° to 25°. Automatic temperature-control devices have become very popular in recent years and their use is spreading rapidly.

#### SELF-CONTAINED AUTOMATIC CONTROLLERS

Automatic temperature controllers, which are also called thermostats, are of two general types, the self-contained and the auxiliary-operated. The self-contained type consists of a bulb to be located in the kiln, a capillary tube connecting the bulb with the motor head of the valve, and the valve itself. The bulb and its connecting tube are filled with a suitable liquid or vapor that expands and contracts respectively with rise and fall of the kiln temperature, causing corresponding changes in pressure in the motor head, which in turn transforms the changes into motion. The movement of the motor head is transmitted through a stem to the valve. Self-contained thermostats, which are set for the temperature desired by means of a spring or sliding weights, are designed for a maximum range in temperature control of about 80° F. For example, if the range in temperature control is from 140° to 220°, the controller will not operate satisfactorily below 140° or above 220°. Since a material change in temperature of the motor head affects its setting, self-contained thermostats should not be placed where the temperature of the motor head approaches the temperature of the kiln, but should be located in a protected place where temperatures are reasonably constant, and of course lower than the kiln temperature; such a place preferably will be an operating pit below the kiln platform.

The principal field of usefulness of the self-contained thermostat is in progressive kilns, where the temperature at the control bulb is intended to be constant, rather than in compartment kilns, where temperatures are changed currently as required by the schedule.



## AUXILIARY-OPERATED AUTOMATIC CONTROLLERS

Auxiliary-operated thermostats for dry-kiln use are made in various types; compressed air, electricity, water, or steam may be employed to operate the valve. The most common are the air-operated type, working under about 15 pounds gauge pressure. As with the self-contained type, the temperature-sensitive element, called a bulb, is located in the kiln and is connected by means of a capillary tube to the valve-operating mechanism outside of the kiln. Temperature changes at the bulb vary the pressure of the liquid or vapor within the bulb and the pressure changes are transmitted to the operating mechanism and then are relayed to a diaphragm-motor valve on the steam supply line; all auxiliary-operated thermostats, except the electrical, require a diaphragm type of motor.

The design of auxiliary-operated thermostats permits their operation through a very wide temperature range. Air-operated thermostats are provided with a pair of small pressure gauges, located on the air lines so as to show the position of the valve, which are of considerable assistance when the operator is making temperature adjustments. This type of thermostat is also manufactured in combination with a recording thermometer in which temperature adjustments are made by a direct-set arm on the face of the recorder chart.

## HUMIDITY-CONTROL DEVICES

Humidity control is obtained by means of the same types of thermostats as those used for temperature control. The bulb in the kiln, however, is covered with a wick dipping in water or is kept moist by other means, so that evaporation at this bulb reduces its temperature (the wet-bulb temperature) below that of the kiln (the dry-bulb temperature). The reduction is proportional to the rate of evaporation, which in turn is inversely proportional to the humidity in the kiln when the circulation past the bulb is sufficient to enable it to give an accurate indication. The thermostat valve that is controlled by the wet-bulb temperature itself governs the steam supply to the sprays, admitting steam when the wet-bulb temperature drops, and closing the line as soon as the steam has raised the humidity to the value corresponding to the (wet-bulb) temperature for which the thermostat is set.

## RECORDING THERMOMETERS

The temperatures and humidities within southern pine kilns are such that it is impractical to obtain temperature readings with ordinary indicating thermometers and hygrometers. Further, such readings are of value only in showing the temperature at the moment the reading is made. Recording thermometers for recording both dry-bulb and wet-bulb temperatures are very generally used and in consequence need no description here;<sup>10</sup> it is enough to say that good, reliable recording thermometers should be part of the equipment of every kiln where any degree of temperature or humidity control is attempted.

<sup>10</sup> See footnote 4 on p. 2.

## LOCATION OF THERMOSTATS AND THERMOSTAT BULBS

Drying schedules are intended to specify the most severe conditions to which the lumber will be exposed during the stage of drying indicated. The most severe drying conditions obtain where the air enters the pile, which in natural-circulation progressive kilns is usually the bottom of the pile at the dry end of the kiln. If the bulb could be located between the heating coils and the lumber, accurate control would be reasonably assured. That position, however, is frequently impractical, and the next best place is usually on the side wall, possibly 20 feet back from the doors at the dry end. In natural-circulation compartment kilns having their characteristic air movement across the kiln, the side wall is again the best position. In forced-circulation kilns it is worth considerable thought and effort to find some means of locating the bulbs in the entering-air position, wherever it may be.

The temperature recorder will often show a wide fluctuation in temperature even with a controller in service in the kiln. Such a fluctuation was observed in a cross-piled compartment kiln where the circulation was supposed to be augmented by steam sprays, but was not so augmented because the sprays had been improperly located in the original installation. The heating coils consisted of one big unit below the rails, and the sprays were just above the coils, pointing upward; the bulb of the controlling thermostat was on a side wall. When the stock was green the circulation was downward from the lumber in spite of the spray, and up the side walls. After the temperature at the bulb had become low enough to open the thermostat governing the supply to the heating coils, some time would elapse before the air movement would carry the now rising temperature up to the bulb. When the bulb temperature reached the point at which the thermostat closed, the hot air moving from the coils to the bulb would still be increasing in temperature. The thermostat was actually opening and closing the steam supply line in accordance with its setting, but because of the slow air movement the temperatures coasted after the thermostat had functioned. In cases like this one the more rapid the circulation the less the variation in temperature. Furthermore, multiple heating units are also of advantage in that with them only a slight excess of heating surface is in use at any time and consequently the coils contain steam at all times, the thermostat acting only to throttle the excess steam.

## HANDLING STOCK BEFORE AND AFTER KILN DRYING

### PILING ON KILN CARS

Careful and proper stacking of the lumber on the kiln cars is a primary factor in successful kiln drying, practically equal in importance to proper kiln operation. Faulty stacking is more or less directly responsible for all of the warping and most of the end checking that occur in the kiln; it contributes to unequal drying and is the indirect cause of most of the splitting at the planer. Very few instances have been found in the southern pine region where the stacking approaches the standards required to keep at a minimum the

degrade caused by this factor. Poor stacking is more a matter of carelessness and lack of appreciation of its importance than a matter of economy in stacking costs, for the standards of stacking discussed hereafter add almost nothing to the labor and only little to the number of stickers, crossties, and kiln trucks, and on the other hand offer several decided economies.

#### METHODS OF PILING

The plant layout usually determines whether the kiln trucks will be piled with the lumber crosswise (pl. 3, C) or lengthwise (pl. 3, A and B) of the kiln; the crosswise method, however, is the more common. Two styles of stacking are also used; flat stacking, in which the boards are laid flat on the trucks and the stickers are horizontal; and edge stacking, in which the boards stand on edge on the truck with the stickers vertical in the load. Edge stacking in southern pine mills is usually combined with cross piling. Flat stacking is more common than edge stacking.

#### REDUCING WARP<sup>22</sup>

It is a characteristic of lumber to tend to warp somewhat while drying; the amount of actual warp depends on the species of wood and on such factors as crookedness of grain, the presence of sapwood and heartwood in the same piece, and the position of the piece in the log, and most of all on the lack of restraint while drying. (Pl. 4.) Further, heat softens wood to some extent, making it less resistant to the internal forces that cause warping and also to any external forces to which the wood may be subjected. Fortunately the softening process reduces the magnitude of the internal stresses at the same time, and thus makes it possible to apply external forces advantageously. The sticker furnishes the external force, resisting the warp and holding the stock flat for a certain distance on each side. The greater the distance between stickers, the greater the amount of warp, and therefore the stickers must be spaced closely enough to hold the warp to a minimum.

The restraint that is exerted by the stickers, of course, comes largely from the weight of the lumber above them. Consequently the lumber in the extreme upper courses, which is restrained only lightly unless weights are placed on the pile, is likely to warp.

#### REDUCING CHECKING AND SPLITTING

Proper stacking will prevent a large part of the waste caused by end checks and splits. End checks that develop during drying will almost always stop at the first sticker they reach. Obviously the proper place for the end stickers is as near the ends of the load as possible. Splits that occur at the planer are principally a result of warp and may be reduced in proportion to the reduction of warp. In one test on southern yellow pine it was found that the waste resulting from trimming to hold the stock on grade was 0.7 per cent when the stickers were at the ends of the load and 2.5 per cent when they were back 6 to 12 inches from the ends. Warp may arise from

<sup>22</sup> Warp is any variation from a true or plane surface. It includes crook, bow, cup, and twist, or any combination of these.

imperfectly manufactured stock, or from placing stock of unequal thickness in the same course; under such conditions the stickers have to bridge over the thin stock unsupported. The weight of the stock above will then bend or break the sticker and will thus cause distortion in the upper courses.

#### GOOD PILING PRACTICE

The limitations of edge piling are such that it is more or less impractical to conform to all of the essentials of good piling when employing the edge method. The following discussion, therefore, is predicated on flat piling although some of the features may be followed in edge piling. The essentials of good piling are (1) a sufficient number of strong kiln trucks in good condition; (2) rigid supports under each line of stickers; (3) stickers of sound, clear material of even thickness and with proper spacing, placing in vertical alignment in the car over the supports; (4) stickers at the extreme ends of the load; and (5) uniform thicknesses of stock in each course.

For end piling either the sticker spacing or the transfer track will determine the location of the kiln trucks; an extra pair of trucks may be required to support the crossties needed in the middle of the train. (Pl. 3, B.) For cross-piled trucks, steel rails or I beams are commonly used under the pile; a reasonable number of them provide a rigid support for the stickers regardless of sticker spacing.

#### BOX PILING

Where stock on a car is of mixed lengths, it should be box piled, with the long lengths on the outside of the pile and the short lengths inside and so placed that one end of each board is on the outside sticker at one end of the car, and with successive short boards in the same course extending to opposite ends. In each succeeding course the outer ends of the short boards should be kept immediately over the ends of those below in order to furnish support for those above.

#### SPACE FOR VERTICAL CIRCULATION IN FLAT PILING

For natural-circulation and combination natural-circulation and forced-circulation kilns in which the principal air movement is vertical, ample space should be left between adjacent flat-piled boards or groups of boards in each course in order to provide a free movement of the air. Such spaces in successive courses should be in vertical alignment so as to form unobstructed air passages (flues) from the top to the bottom of the pile. These flues should be not less than 4 inches wide, and if the circulation is feeble or if the drying is not substantially uniform throughout the kiln charge the width should be increased, up to a maximum of 6 inches. The distance between flues should not exceed 14 inches, and 12 inches is better; the smaller distance may be obtained by grouping three 4-inch boards, two 6-inch boards, one 4-inch and one 8-inch, and so on.

## STICKERS

The stickers should be made of clear, straight-grained stock, entirely free from both stain and decay, and should be dressed to a uniform thickness of not less than seven-eighths inch for flat-stacked piles. If the stickers are made about one and one-half times as wide as they are thick they will lie flat instead of tending to roll when the boards are laid upon them. Sometimes stickers 3 to 4 inches wide are used but this is poor practice because such stickers cover so much surface that the drying is unequal and checks are likely to develop in the lumber underneath them. (Pl. 5.)

In edge stacking the size and the requirements of the stacking machine may determine both the width and the thickness of the stickers.

The stacking racks and machines used for edge piling in the South usually limit the stickers to three rows in the length of the pile; the flow of air is through the spaces between stickers. The kiln trucks ordinarily are not provided with an automatic take-up device of sufficient capacity and hence it is quite common, when the lumber is partly dried and shrinkage has begun, for layers or parts of layers to fall between stickers, thus closing up some of the air passages. (Pl. 6.)

## LOSS CAUSED BY IMPROPER STICKERING

Numerous tests have been made to demonstrate the advantage of proper piling for No. 2 Common and Better stock. The results of some of these tests follow. A 16-foot load of longleaf pine, 6-inch and wider, No. 2 Common and Better, piled with six stickers varying in spacing from 2 feet 6 inches to 4 feet 8 inches, with the sticker lines placed over crossties, was compared with a load of similar stock having stickers 2 feet apart. The stock was dried in a progressive natural-circulation kiln without temperature or humidity control, and was run through the planer and graded about 24 hours after leaving the kiln. Table 9 shows the average depreciation in value per thousand board feet of each load.

TABLE 9.—Comparison of losses caused by degrade, for kiln drying under conditions differing only in the spacing of the stickers, in 6-inch and wider longleaf pine lumber 6, 8, 10, and 12 feet long

Grade of stock	Losses caused by degrade when using—			
	Six sticker tiers spaced from 2 feet 6 inches to 4 feet 8 inches		Sticker tiers 2 feet apart	
	Stock on grade	Loss per 1,000 board feet <sup>1</sup>	Stock on grade	Loss per 1,000 board feet <sup>1</sup>
	Per cent	Dollars	Per cent	Dollars
B and Better.....	85.7	5.90	90.8	3.37
No. 1 Common.....	68.6	9.38	77.7	5.74
No. 2 Common.....	53.3	1.59	62.0	1.23

<sup>1</sup> Based on lumber prices substantially the same as those for January, 1923.

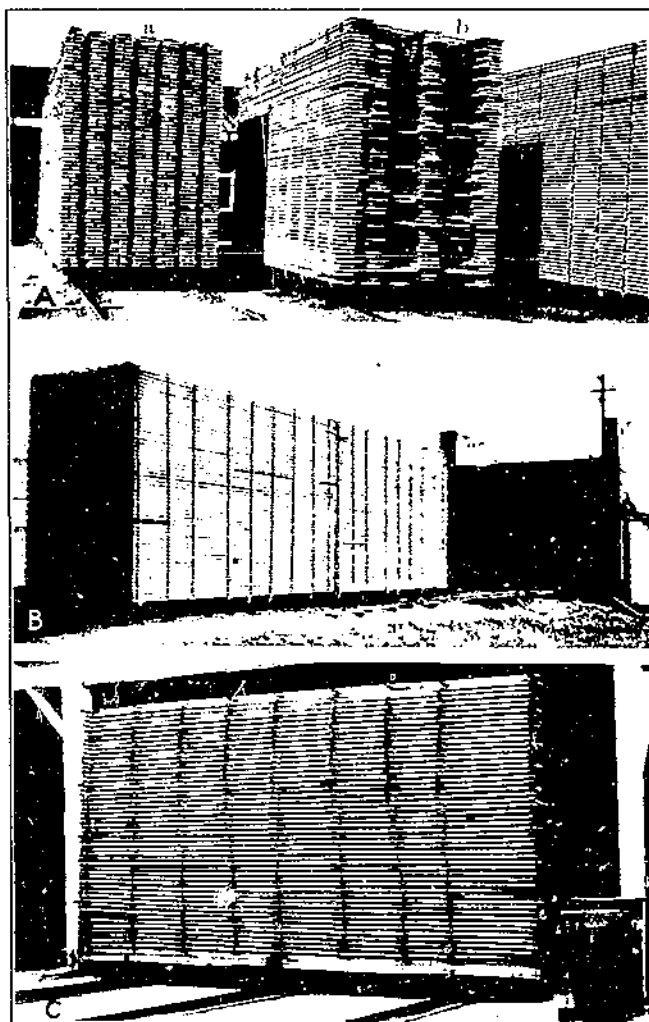

M-1442 C. M-997 F

Flat end piled truck loads of southern yellow pine are shown in A and B. In A, the number of stoker tiers is sufficient, each tier of stickers is supported by a tie directly under it, all of the boards in each course are of the same thickness, the narrow boards are grouped in pairs, and the sides and the ends of the pile are uniform and vertical, all of which is highly desirable. On the other hand, placing the outer stickers at the extreme ends of the boards would reduce both warping and end checking, and uniformity of the vertical air channels through the pile would give faster and more even drying. Box piling is illustrated in A, B. The short lengths are inside the outer tiers of full-length boards and are staggered from end to end of the pile. Although box piling in itself is excellent practice, the vertical air channel at the left of the pile illustrated is either fully closed or badly obstructed at several points, such nonuniformity causes slow and uneven drying. The two loads shown in B are piled even better than those in A. In addition to showing good piling in general, these loads illustrate the use of three pairs of trucks under a single load, each three pairs of cross-ties are supported on a pair of trucks. The general features of the flat cross piling of southern yellow pine in C are excellent. The five courses of common lumber piled solid for the support of the load, however, are an expensive practice because of poor seasoning and excessive degrade in the pieces used, extra chomling, and also because of the deformation they permit in the lumber they are supposed to sustain. Pile supports of steel I-beams or rails pay for themselves in a short time, even better tubes selected from discards may be used to advantage.



M-2357-F; M-5612-F

A.—An example of particularly bad stickering. The vertical misalignment of the stickers causes bowing of the boards. Further, the inequality of the spaces between stickers will certainly cause unequal drying and may cause abraze. B.—Three tiers of stickers, even though in good vertical alignment, have failed to provide sufficient support in these truck loads and consequently the stock is badly bowed and twisted, and some break is evident. The overlapping ends made matters worse. The excessively wide lines in the piles sacrifice kiln capacity and tend to produce overlying in some parts of the stack, while the nonuniformity of the same air channels certainly causes uneven drying; some lines are badly obstructed by the poorly filled boards.

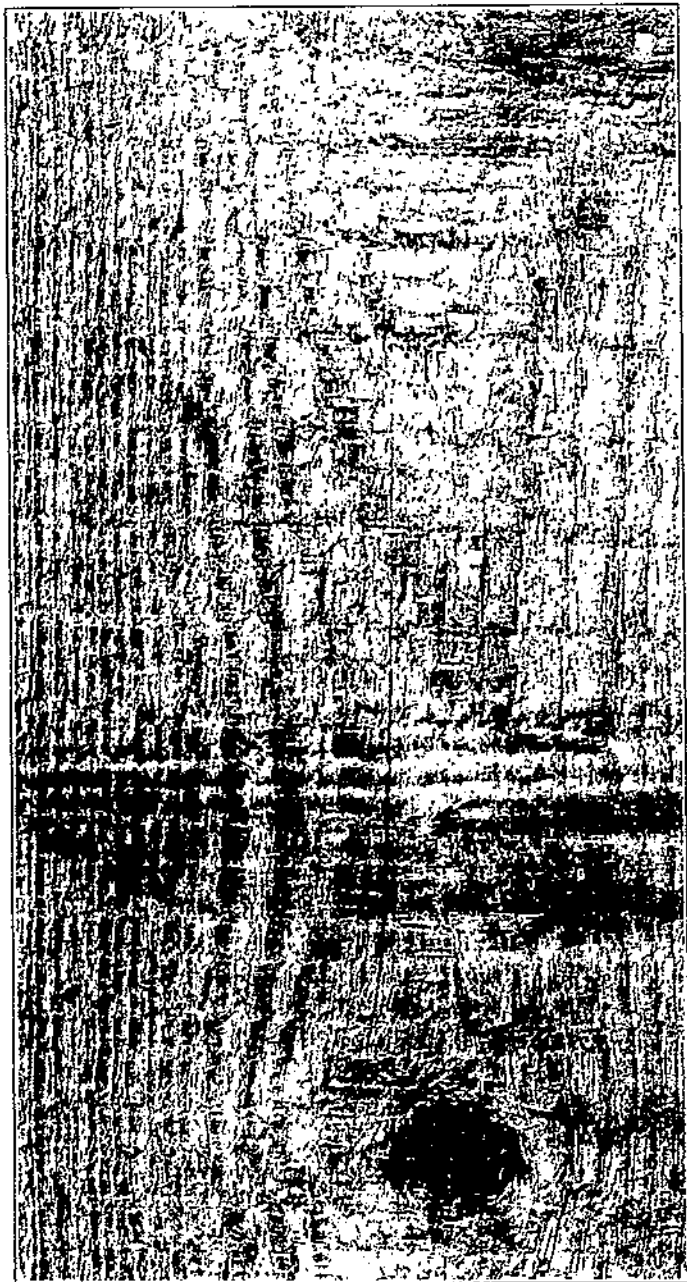

64 -259 -F

A check in 1 by 6 inch lumber resulting from the uneven drying caused by an excessively wide sticker. Narrow stickers, from  $1\frac{1}{4}$  to 2 inches in width, permit better drying of the wood they cover.



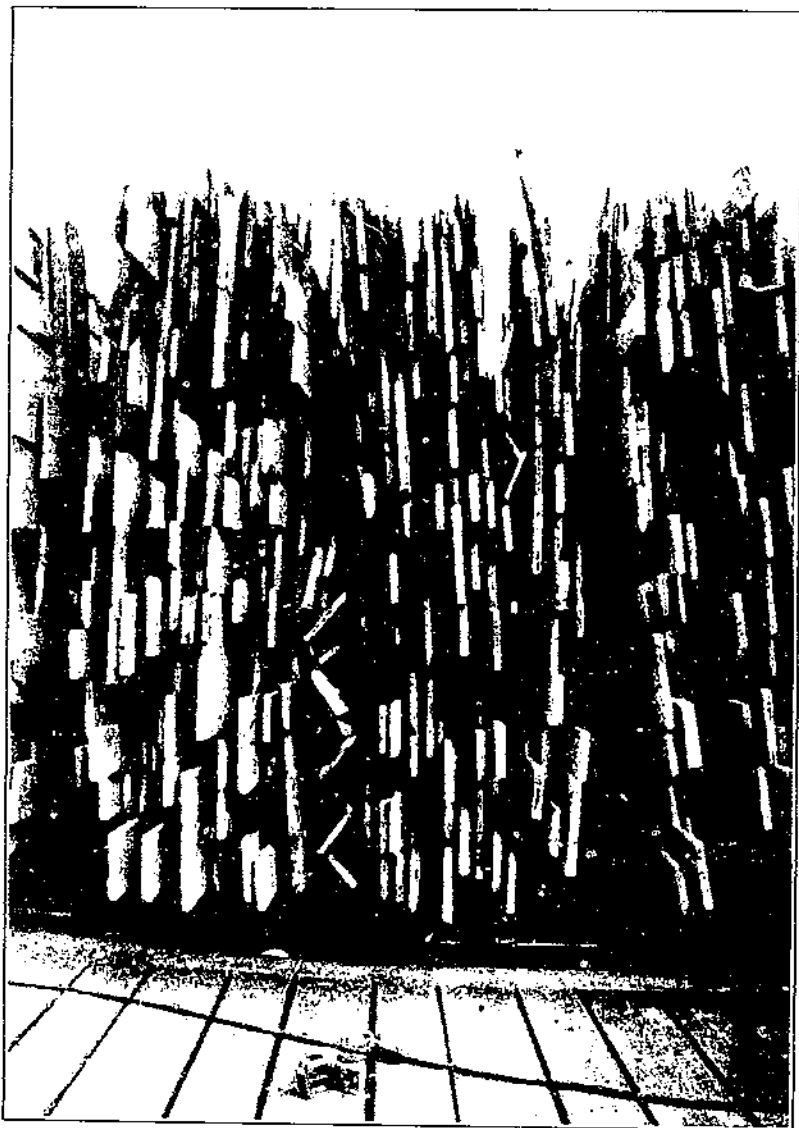

M-3008-F

Edge-stacked lumber with tumbled tiers as a result of carelessness at the time of stacking. The position of the lumber causes poor drying in such tiers and often causes severe checking also. Shrinkage during drying sometimes results in tumbling as bad as this, especially when automatic take-up devices are not used or are inadequate.

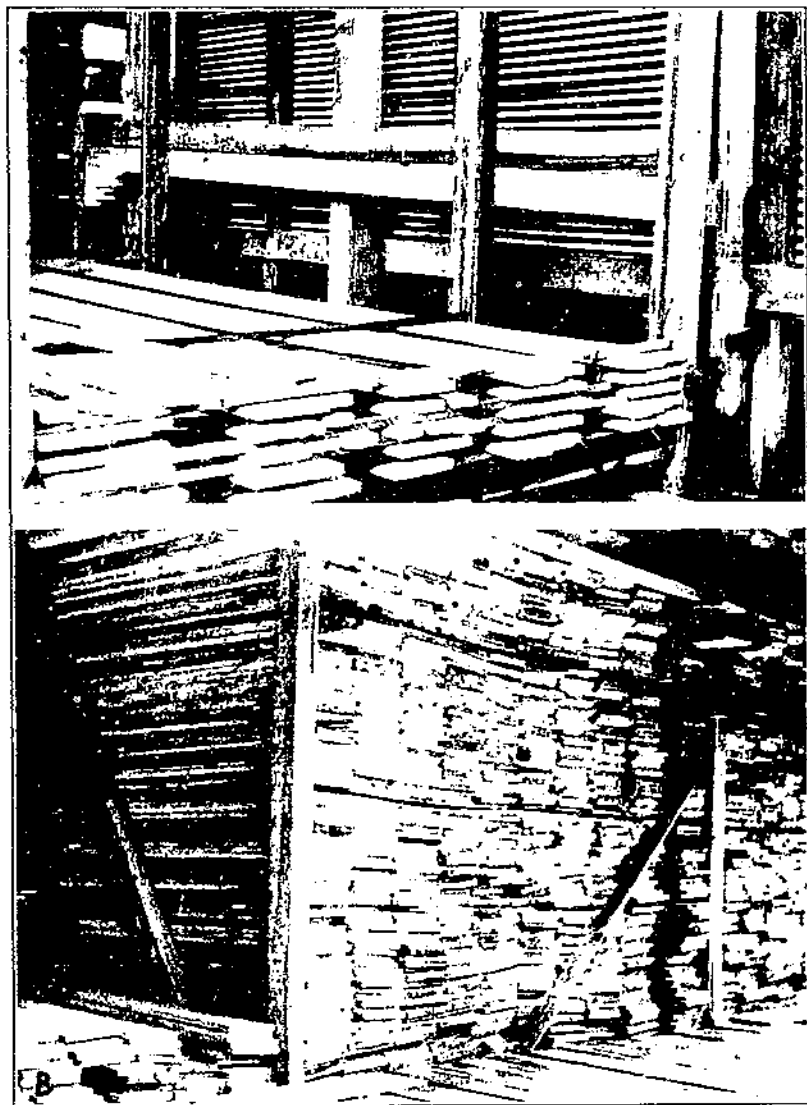

B. L. 4293 F. M. 1631 P.

A. Stacker guides for stacking southern yellow pine lumber for kiln drying. The use of such guides is good practice, since it reduces both piling costs and kiln degrade, but enough guides should be provided for all the tiers of lumber that the stack needs. B. A 1 or grade kiln-dried lumber bulk piled in a rough-dry shed. The cracks forming in the courses about 5 feet from the floor is likely to cause splitting. Proper truck piling for periods of three weeks or more is beneficial to warped and unevenly dried stock and also to case-hardened stock.

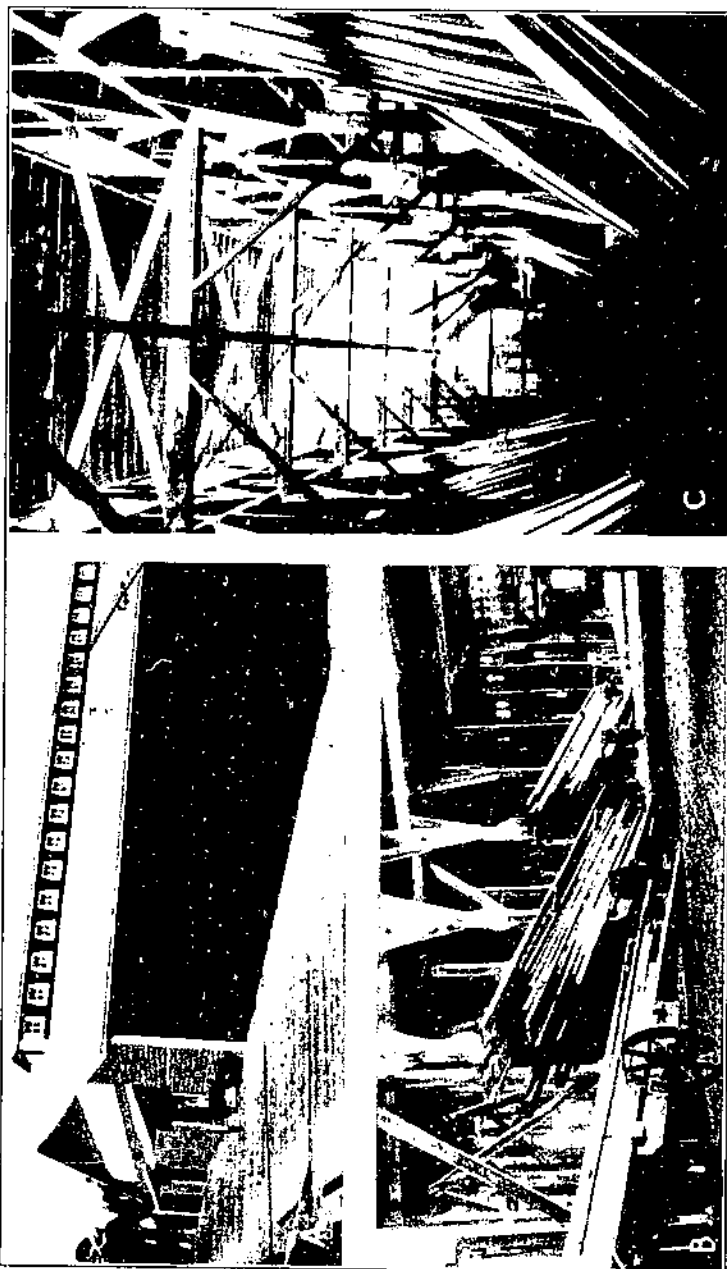

81-156-F

An enclosed shed suitable for the storage of stock both before and after milking. The humidity within such sheds is normally lower than that in open sheds and consequently the moisture content of stock in enclosed sheds will average lower than that in open sheds. A. - The exterior view. B. - Bulk-piled rough stock on lugs ready for the planing mill. C. - The usual method of storing dressed sawtimber, well planed. Stock stacked on lugs has less surface covered by adjacent boards than bulk-piled stock and consequently reacts more quickly to the atmospheric conditions in the finish shed.

In another test on longleaf pine only four sticker tiers, placed 4 feet apart with the stock overhanging 2 feet at each end, were used; this is a method of piling very common at many southern pine mills. Kiln cars so loaded were dried along with some 9-sticker loads in kilns having forced circulation, accurate temperature and humidity control, and a drying schedule similar to those recommended in this publication. Here again all the stock was run through the planer the day following its removal from the kiln, and was graded and tallied behind the planer. The average depreciation in value per thousand board feet appears in Table 10. A similar test was made on 8-inch No. 2 Common shortleaf pine in a typical progressive kiln. The depreciation in value of this stock appears in Table 11.

TABLE 10.—Comparison of losses caused by degrade in 4-sticker and 9-sticker piles of 8-inch upper-grade longleaf pine

Grade of stock	Loss caused by degrade when using—			
	4 stickers per course		9 stickers per course	
	Stock on grade	Loss per 1,000 board feet <sup>1</sup>	Stock on grade	Loss per 1,000 board feet <sup>1</sup>
B and Better, S4S.....	Per cent 73.30	Dollars 3.60	Per cent 97.19	Dollars 0.60
No. 1 Common, S4S.....	84.40	3.17	97.95	.64

<sup>1</sup> Based on lumber prices substantially the same as those for January, 1929.

TABLE 11.—Comparison of losses caused by degrade in 4-sticker and 9-sticker piles of 8-inch No. 2 Common shortleaf pine

Run No.	Loss caused by degrade when using—			
	4 stickers per course		9 stickers per course	
	Stock on grade	Loss per 1,000 board feet <sup>1</sup>	Stock on grade	Loss per 1,000 board feet <sup>1</sup>
.....	Per cent 60.0	Dollars 1.72	Per cent 78.8	Dollars 1.16
.....	83.7	.93	91.0	.51
.....	82.4	.98	85.4	.81

<sup>1</sup> Based on lumber prices substantially the same as those for January, 1929.

Very slight cupping will cause dry southern yellow pine stock to split as the stock is flattened on the planer bed, and will also increase the breakage and the loosening of knots. The support given to the stock by suitable stickers spaced about 2 feet apart almost entirely prevents distortion during drying. In the test, crook was found to be very common in the 4-sticker stock, particularly slight and medium crook, which in itself was not severe enough to cause degrade. In the 9-sticker lots there was almost no crook, although what was found was pronounced and usually was enough to cause degrade. The tests have shown that the close sticker spacing prevents most of the

crook, particularly the slight and medium, but where very pronounced compression wood occurs on the edge of the piece crook develops in spite of the restraint of the stickers.

#### COMPARISON OF FLAT AND EDGE STACKING

While flat stacking is the rule at the majority of the southern pine mills (pl. 7, A), the possibility of using mechanical stacking and unstacking equipment has induced some mills to adopt edge stacking in the expectation of a reduction in labor costs. Edge-stacked lumber, however, is more free to warp in drying and consequently the degrade from planer splitting is increased proportionately. Three tests were made at one mill cutting shortleaf pine, in which one car each of edge-stacked and of flat-stacked lumber was put through the same kiln at the same time, with the results shown in Table 12.

TABLE 12.—Comparison of losses caused by degrade in edge-stacked and in flat-stacked 1 by 8 inch No. 2 Common shortleaf pine

Run No.	Loss caused by degrade in lumber—			
	Edge-stacked, using 3 tiers of stickers		Flat-stacked, using 9 tiers of stickers	
	Stock on grade	Loss per 1,000 board feet <sup>1</sup>	Stock on grade	Loss per 1,000 board feet <sup>1</sup>
	Per cent	Dollars	Per cent	Dollars
1.....	91.6	2.09	78.8	1.10
2.....	87.6	2.34	85.4	.81
3.....	84.4	.85	97.6	.13

<sup>1</sup> Based on lumber prices substantially the same as those for January, 1929.

The tests of Table 12 were made in progressive natural-circulation kilns in which the temperature was under automatic control. In run 3 the humidity was automatically controlled as well and the steam sprays were so installed as to augment the natural circulation; overdrying was prevented by using proper final humidities. It is quite apparent from these tests that, whether southern yellow pine is dried with or without suitable humidity control, flat-stacked stock piled with numerous rows of stickers gives the better results.

#### STORAGE AFTER KILN DRYING AND BEFORE MACHINING

It has been pointed out that there are three major independent factors in seasoning stock in preparation for planing, two of which—kiln operation and stacking for the kiln—have been examined. The importance of the third—storage of kiln-dried rough stock in dry shed (pls. 7 B and 8)—depends largely upon the conditions maintained in the kiln. The discussion following deals only with the effect of storage on kiln degrade; it is not concerned with the other purposes and with the general advantages of the practice of dry storage.

The moisture content of stock at the time of machining has a very important bearing upon degrade. If the stock is overdry, the

tongues, grooves, and beads tear and break and the plain surfaces chip. Such stock also splits and checks badly, and any cup or twist greatly increases the damage. Underdry stock does not plane smoothly. Stock as it leaves the kiln often varies widely in moisture content, particularly with natural-circulation kilns, some pieces as low as 2 per cent moisture content and other as high as 20 per cent or more coming from the same kiln charge of upper-grade stock. When stored in bulk the tendency is for all pieces to come to a moisture content in equilibrium with the atmosphere. When stock is piled solid, the pieces of high-moisture content transfer moisture to those of low-moisture content, and the pile, as a whole, gradually and slowly attempts to reach the equilibrium moisture content. The exposed, overhanging ends will rapidly reach this condition, but within the pile several weeks or even months may elapse before the moisture content is equalized. Narrow flooring strips will come to equilibrium more rapidly than wide boards, since the percentage of free air space and the resulting ventilation within the pile is greater for the strips.

In an average dry shed, so constructed as to protect the stock from driving rains, the equilibrium moisture content of the stock as found by tests made on overhanging ends will range from 8 to 12 per cent, depending upon the time of year and the outside atmospheric conditions. Ordinarily the shed conditions are such that all the stock will have a lower moisture content than the same material would have if it were stored in piles in the open. Further, the moisture content of stock within the piles will usually be lower than that in the overhanging ends. In some tests made on longleaf flooring strips in storage three weeks the overhanging ends showed a moisture content of 10.5 to 11.5 per cent, while the portions of the same pieces within the pile contained only from 6.5 to 9 per cent moisture.

The atmospheric conditions within unheated sheds are actually such that the equilibrium moisture content of lumber stored in them may attain a value above that desired for upper-grade stock, but the rate of absorption in bulk piles is quite slow and a considerable period of time elapses before the interior of a fresh pile is affected. On the other hand, if the moisture content at the ends of the piles, especially that of the projecting portions of overhanging ends, varies from the moisture content of the portion of the board within the pile some distortion in shape will follow after machining. For example, flooring strips such as those already described may contain at the time of machining about 11 per cent moisture throughout 2 or more feet at one end where the end overhung the main portion of the pile, and perhaps 6 per cent throughout the rest of the strip. Later, after the moisture content has become uniform throughout the length of the machined piece, the dimensions will not be the same in the end section as in the rest of the piece. Stock in this condition is sometimes found in the finish shed before shipment and very frequently is found at the retail yards or after delivery to the building where it is to be used.

Overhanging ends obviously should be avoided in so far as possible. Further, where assurance of moisture control for the lumber in storage is desired, the sheds should be inclosed on all sides and provided with a heating system for use in cold or damp weather.

Casehardening stresses are relieved to some degree by the slight gradual changes in moisture content of stored stock, as it follows slowly the variation in atmospheric humidity. In this respect the action is quite similar to that obtained by means of the steaming process called for in the drying schedules, but the results are less positive and by comparison are very slow. Casehardening tests on longleaf pine flooring strips that had been dried in a natural-circulation progressive kiln and stored three weeks indicated that there was very little stress present, but the same kind of stock as it left the kiln was quite severely casehardened. Twist, bow, and cup are to some extent ironed out in storage under the weight of the pile.

Bulk piling, however, does not particularly affect the degrade caused by knots. In a test on 8-inch No. 2 Common longleaf somewhat overdried in a progressive natural-circulation kiln, the degrade when the stock was run direct from the kiln to the planer was 53.8 per cent, but after bulk piling for 30 days the same kind of stock had a degrade of only 28.5 per cent. The degrade charged to damaged knots was 15.4 and 14.9 per cent, respectively, while that charged to splits was 37.4 and 12.8 per cent, respectively. The moisture content of the stock at the kiln door averaged about 5 per cent and after storage 11 per cent.

Long periods of storage after drying, such as 6 to 12 months, are particularly beneficial, providing the stock does not pick up too much moisture, and even short periods of 10 to 20 days cause a marked improvement in flooring strips and narrow finish. Fifteen days in the rough shed raised the proportion on grade of 1 by 4 inch B and Better flooring strips from 88.5 to 92.7 per cent. Six months raised 1 by 8 inch B and Better from 87.5 to 94.6 per cent.

Storage in the rough shed for a minimum period of three weeks will prove economically worth while for the product of the ordinary type of natural-circulation progressive kiln, in which it is impracticable to follow a drying schedule that requires maintaining a humidity of at least 40 per cent for No. 1 Common and Better and 50 per cent for No. 2 Common stock. On the other hand, with kilns where these humidity conditions can be maintained there will not be enough saving in degrade to pay the handling costs of such storage. Where it is possible to steam the stock in the kiln immediately before removal, storage is not justified as a means of reducing degrade. Each handling of stock causes a certain amount of degrade, and the cost of handling and the attendant overhead suggest that such stock should be run direct from kiln to planer whenever possible. The sizes and grades in common demand can be run direct, and the storage shed can then be used to accumulate the items not moving rapidly, to permit the separation of grades, and to hold stock in the rough until it is needed to fill orders.

#### MACHINING KILN-DRIED STOCK

From a large number of moisture determinations on southern yellow pine that was leaving the planer, made in various studies of degrade, it appears that the range of moisture content through which the best planer work is obtained is from above 5 per cent to below 18 per cent. As the moisture content drops below 5 per cent, planer

splitting, torn grain, and chipping increase, and above 20 per cent the surface is rough and fuzzy. There would be less damage to knots if the moisture content of the stock containing them were not below 7 per cent for knots up to 1 inch in diameter, and were 10 to 12 per cent and even higher for large knots. Most No. 1 Common and Better southern yellow pine, however, is used for interior work or in similar service in which the ultimate moisture content will ordinarily range between 6 and 9 per cent, and knotty stock admitted to these grades will have to run the risk of damage when it must be dried below 8 per cent. The uses to which No. 2 Common southern yellow pine is put are less exacting in regard to final moisture content and hence, whenever practicable, this stock should not be dried below 10 per cent. For low-grade lumber that contains an abundance of large knots the retention of a moisture content of at least 10 per cent is particularly important; to assure lowest degrade from knots, Schedule 108 should be modified so that the humidity will at no time go below 60 per cent. This can be accomplished by changing the conditions after 35 hours in the kiln from 190° F. dry bulb and 170° wet bulb to 200° dry bulb and 177° wet bulb.

#### PLANER DEFECTS

In common practice substantially all degrade occurring at the planer has been charged against the seasoning method and the planer itself has been considered responsible only for the most obvious planer defects. Actually, however, the planer is responsible for an important although usually undetermined proportion of the so-called kiln degrade. For instance, in an investigation of the matter, inconsistencies between different tests on stock of the same grade and from the same kiln charge, run at different times, appeared plainly. Because of the test conditions the only inference that could be drawn from this observation was that the planer set-up was not always uniform and that some factor connected with the planer set-up was responsible for the inconsistency.

It is to be expected that degrade will be least in narrow stock and greatest in wide stock and in degrade tests this expectation holds for stock 6 inches and wider but not for flooring strips. In fact, flooring often has a higher degrade than the widest stock run, although the degrade in 4-inch stock when surfaced four sides is very low. The factor causing most of the degrade in flooring strips is broken tongues and grooves, primarily a machine defect and not a kiln defect, and if this factor were excluded the degrade in the narrow stock would generally be lower than that in wide stock.

A tally was made of some B and Better flooring that had been very carefully dried and conditioned in the kiln. Tests before planing showed that the stock was free from casehardening and had quite a uniform moisture content, which averaged 8 per cent. The object of this test was to determine separately for each item the percentage of tongues and grooves that were broken sufficiently to cause a drop in grade. Table 13 presents the results of the test.



TABLE 13.—Comparison of *degrade in edge-grain and in flat-grain southern yellow pine flooring*

Type of flooring	On grade	Broken tongues	Broken grooves	All other defects
Edge grain.....	<i>Per cent</i> 78.10	<i>Per cent</i> 3.25	<i>Per cent</i> 18.30	<i>Per cent</i> 4.35
Flat grain.....	86.43	.60	1.78	1.19

Edge grain is more liable to planer damage than flat grain on account of splitting along the growth rings in the thin, projecting tongues and groove sides, since the rings are at right angles to the projections in edge grain and parallel in flat grain. Most of the broken grooves develop in the flange that is uppermost as the piece goes through the planer.

The tests involving planer defects indicate that the machining operation is in need of improvement, that the planer set-up is not always uniform, and that outfeed rolls and the pressure bar are not always best suited to the item being manufactured.

### PROTECTING THE FINISHED PRODUCT

After stock has left the kilns further changes in moisture content depend upon the conditions to which it is exposed, as has been explained under "Storage after kiln drying and before machining." After machining, many stock items are stored in bundles, sometimes on end in the finish shed, a form of storage that permits fairly rapid equalization where the stock is below the equilibrium moisture content at the time of machining.

The equilibrium moisture content for stock fully exposed to the atmosphere, under sheds, will vary more or less with the season and somewhat with the locality. During dry spring and summer weather the moisture content of stock after several weeks of such storage may not exceed 7 to 9 per cent. During average winter weather it may go to 11 or 12 per cent, and during protracted damp weather in any season it may run as high as 14 per cent. Some localities have more dry or more damp weather than others. Some mills have sheds that are very open and consequently react to outside weather conditions more quickly than those that are more protected.

Where it is desired that the moisture content of the stock in storage be kept below 9 per cent at all seasons, the sheds should be made tight and some method of heating should be provided. To hold stock below 9 per cent moisture content at an average temperature of 70° F. requires a relative humidity of about 47 per cent (fig. 3). If the humidity is above 50 per cent at this temperature, the heating coils can be turned on and the humidity thus lowered. Heat may be required even in the summer if the weather is damp, but in the United States it will certainly be needed continuously during cold weather.

The operators who handle stock carefully to prevent moisture changes will need to consider the storage conditions at wholesale and at retail distributing points fully as important as their own. Since stock may be held at each of these points for any length of

time up to several months, the period of storage after stock leaves the mill may easily be far greater than that of the storage at the mill. Such operators, therefore, should decline to accept responsibility for the ultimate moisture content of properly dried stock when later storage conditions are unsatisfactory.

#### MOISTURE CONTENT OF LUMBER ON SHIPMENT AND ON RECEIPT

In order to obtain comprehensive information on the moisture content of softwood lumber at the time of shipment from representative first-class mills, the Forest Products Laboratory has carried out an extensive survey. It was conducted during the winter of 1926-27 in five softwood regions, namely: The southern pine region, the Inland Empire,<sup>18</sup> the Pacific Northwest,<sup>19</sup> the redwood region, and the California pine region, during the summer of 1927 in the southern pine region, and again during the summer of 1928 in the Inland Empire, the Pacific Northwest, and California. The tests were made on lumber just as it was being shipped and on as wide a variety of grades and products at each mill as the shipments permitted. In some cases the stock had been machined as it left the dry kiln, whereas in other cases it had been taken from the rough shed to the machine. When the stock had been stored, the time in the rough shed became a factor of some importance because of its effect on the moisture content. As explained on page 59, stock so stored over long periods tends to come to a moisture content in equilibrium with the atmospheric humidity; this moisture content has been found to vary from 10 to 13 per cent for stock that had been stored for several months in various rough sheds in the southern pine region. The average moisture content of 4/4-inch shortleaf stock, taken from the storage sheds, was found to be 10.5 per cent in summer and 11.6 per cent in winter. The average moisture content of longleaf pine was approximately 8 per cent in both the summer and the winter survey, but the storage period averaged 50 per cent longer in the summer than in the winter. Direct from the kiln, the average moisture content of the shortleaf in summer was 9.6 per cent and in winter 9.8 per cent, and of the longleaf was 8.1 per cent in summer and 9.1 per cent in winter. The average moisture content of different lots—that is, of various items of a shipment—varies somewhat both above and below the figures given, particularly for the stock tested as it left the kilns. The tests on car shipments proved that moisture pick-up in dry stock during transit is negligible even in very wet weather, provided that the freight cars are reasonably tight. Exposure to rain during loading or unloading, however, may be quite important.

#### DRY-KILN CONSTRUCTION AND MAINTENANCE

A discussion of dry-kiln construction in general is not within the province of this bulletin but, since dry kilns are subject to certain conditions not common to other types of structures, it seems worth

<sup>18</sup> Northwestern Montana, Idaho north of the Salmon River, Washington east of the Cascade Mountains, and the northeastern tip of Oregon.

<sup>19</sup> The wooded country in Washington and Oregon west of the crest of the Cascade Mountains.

while to comment on these conditions. The dry-kiln structure, regardless of the materials used, deteriorates more rapidly than ordinary buildings. Probably the principal cause, where brick, tile, or concrete is used, is the wide temperature changes and the resultant expansion and contraction of the walls and roof. If the kilns could be kept at a temperature nearly constant, passing only through the relatively small range occurring in the drying schedule, the effect of thermal expansion would be negligible. At times, however, it is necessary to shut down the kilns, and the walls contract as they cool, nearly to atmospheric temperature, and expand again when the heat is turned on. Cracks that develop as a result of this extreme condition continue to grow larger and larger. The long interior partitions of a battery and the outside walls parallel to them are usually cracked close to the doors, and monolithic concrete roofs, especially those on batteries of many units, tend to push the outside walls out of plumb, so that it is not uncommon in old batteries to see such walls braced to prevent them from falling outward.

While expansion and contraction can not be avoided, their bad results may be minimized. In order that this may be done, first, the shutting down of the kilns should be avoided as far as possible and, when a shutdown is unavoidable, the doors should be kept closed to retain the heat as long as possible. If the shutdown is for a short time, doing this will prevent contraction, and if for a long time will equalize it. Then when pointing up cracks in masonry, instead of mortar an elastic putty should be used, one that can expand and contract with the changes in the size of the crack. Such a putty, which is used around windows in brick walls, can be purchased from dealers or can be made up by mixing asbestos flour in asphaltic paint. In new batteries, a dovetail expansion joint should be provided in brick, tile, or concrete end walls and interior partitions, 4 to 6 feet back from the doors. This joint should be about one-half to three-quarters inch wide on the face of the wall and should be pointed up with elastic putty. Concrete roofs should be provided with a 1-inch expansion joint over every other bearing wall.

Heat passes through concrete more readily than through other usual building materials; brick, tile, and wood follow concrete in heat conductivity, in the order given. Vapor also passes through concrete to such a degree that operators find it more difficult to maintain high humidities in concrete kilns than in brick or tile kilns. Good, hard, burned brick, laid in tempered cement mortar, makes about as suitable a material for walls as can be obtained. Tile sometimes disintegrates under kiln conditions, and the expansion cracks in tile walls seem to be larger than those in brick walls, probably because of the larger individual unit in tile construction. There are many tile kilns giving satisfaction in service, however, and the tile and concrete-joist construction seems to make a very serviceable type of roof. Only the best quality, thoroughly burned tile or brick should be used in kiln construction; soft, underburned tile and brick disintegrate rapidly when subjected to the various combinations of heat and moisture in the kiln.

Where insurance rates and other limitations permit, a well-built wooden kiln is reasonably satisfactory. The high temperatures used in southern pine kilns cause a slow breaking down of the wood sub-



M-247 F

Artificial smoke showing the leakage of air into a natural-circulation kiln at the bottom of a door. Inleakage occurs through any openings in the lower half of such kilns, and outleakage in the upper half.

stance through a process of distillation, which shortens the life of the kiln. This process is much more rapid at temperatures above 220° than below 200°, and if wood is used the lower maximum temperatures are suggested as a means of prolonging the life of the kiln.

Doors too frequently are the source of enormous heat and vapor loss, and the cause of unequal drying near the ends of the kiln. Practically no design of door has worked out satisfactorily in all respects. The requirements of a good door are that it be tight fitting to prevent leakage (pl. 9), light in weight for ease in handling, and well insulated to conserve heat and thus prevent unbalancing of the kiln circulation.<sup>20</sup>

A very good door is made of wood and 3-ply roll roofing, using three thicknesses of 1-inch wood for the stiles and the rails, two thicknesses of the felt separated 1 inch for the panels, and one-half by 3-inch strips protecting the felt. Sometimes, in southern pine kilns, the inside of such a door is covered also with sheet metal. Asbestos composition board is sometimes used in place of the felt for the panels, in which event the wood protecting strips are dispensed with. Doors of the general type described are comparatively cheap, are easy to repair, and may be built by the plant carpenters.

Doors are sometimes made of light angle iron covered with corrugated iron, which in turn is covered with roofing felt. Some additional insulation, such as 1-inch sheet cork, should be used on such doors, since otherwise the heat loss through them is too great.

---

<sup>20</sup> Clouds of vapor escaping around the door jambs indicate loose-fitting doors. A door that is uncomfortably warm to the hand is poorly insulated; this test should be made when the kiln is operating at the highest temperature of the drying schedule.

## LITERATURE CITED

- (1) HUBERT, E. E.  
1924. EFFECT OF KILN DRYING, STEAMING, AND AIR SEASONING ON CERTAIN FUNGI IN WOOD. U. S. Dept. Agr. Bul. 1202, 20 p., illus.
- (2) SUDWORTH, G. B.  
1927. CHECK LIST OF THE FOREST TREES OF THE UNITED STATES, THEIR NAMES AND RANGES. U. S. Dept. Agr. Misc. Circ. 92, 295 p.
- (3) TRESDALE, L. V.  
1920. MANUAL OF DESIGN AND INSTALLATION OF FOREST SERVICE WATER SPRAY DRY KILN. U. S. Dept. Agr. Bul. 894, 47 p., illus.
- (4) \_\_\_\_\_  
1927. THE CONTROL OF STAIN, DECAY, AND OTHER SEASONING DEFECTS IN RED GUM. U. S. Dept. Agr. Circ. 421, 18 p., illus.
- (5) THELEN, R.  
1929. KILN DRYING HANDBOOK. U. S. Dept. Agr. Bul. 1136, 96 p., illus.
- (6) TIEMANN, E. D.  
1917. THE THEORY OF DRYING AND ITS APPLICATION TO THE NEW HUMIDITY-REGULATED AND RECIRCULATING DRY KILN. U. S. Dept. Agr. Bul. 509, 28 p., illus.
- (7) UNITED STATES DEPARTMENT OF COMMERCE. NATIONAL COMMITTEE ON WOOD UTILIZATION.  
1928. SEASONING, HANDLING, AND CARE OF LUMBER (CONSUMERS' EDITION). U. S. Dept. Com., Natl. Com. on Wood Utilization, Consumers' Subcom. Rpt. 4, 63 p., illus.
- (8) \_\_\_\_\_  
1928. SEASONING, HANDLING, AND CARE OF LUMBER (DISTRIBUTORS' EDITION). U. S. Dept. Com., Natl. Com. on Wood Utilization, Distributors' Subcom. Rpt. 6, 74 p., illus.
- (9) \_\_\_\_\_  
1928. SEASONING, HANDLING, AND CARE OF LUMBER (FABRICATORS' EDITION). U. S. Dept. Com., Natl. Com. on Wood Utilization, Fabricators' Subcom. Rpt. 7, 96 p., illus.
- (10) \_\_\_\_\_  
1929. SEASONING, HANDLING, AND CARE OF LUMBER (MANUFACTURERS' EDITION). U. S. Dept. Com., Natl. Com. on Wood Utilization, Manfrs.' Subcom. Rpt. 9, 126 p., illus.
- (11) WILSON, T. R. C.  
1920. THE EFFECT OF KILN DRYING ON THE STRENGTH OF AIRPLANE WOODS. Natl. Advisory Com. Aeronautics Ann. Rpt. 5: 473-537, illus. (Tech. Rpt. 68.)

## ORGANIZATION OF THE UNITED STATES DEPARTMENT OF AGRICULTURE

January 8, 1930

<i>Secretary of Agriculture</i> .....	ARTHUR M. HYDE.
<i>Assistant Secretary</i> .....	R. W. DUNLAP.
<i>Director of Scientific Work</i> .....	A. F. WOODS.
<i>Director of Regulatory Work</i> .....	WALTER G. CAMPBELL.
<i>Director of Extension Work</i> .....	C. W. WARDURTON.
<i>Director of Personnel and Business Administration.</i>	W. W. STOCKBERGER.
<i>Director of Information</i> .....	M. S. EISENHOWER.
<i>Solicitor</i> .....	E. L. MARSHALL.
<i>Weather Bureau</i> .....	CHARLES F. MARVIN, <i>Chief.</i>
<i>Bureau of Animal Industry</i> .....	JOHN R. MOHLER, <i>Chief.</i>
<i>Bureau of Dairy Industry</i> .....	O. E. REED, <i>Chief.</i>
<i>Bureau of Plant Industry</i> .....	WILLIAM A. TAYLOR, <i>Chief.</i>
<i>Forest Service</i> .....	R. Y. STUART, <i>Chief.</i>
<i>Bureau of Chemistry and Soils</i> .....	H. G. KNIGHT, <i>Chief.</i>
<i>Bureau of Entomology</i> .....	C. L. MARLATT, <i>Chief.</i>
<i>Bureau of Biological Survey</i> .....	PAUL G. REDINGTON, <i>Chief.</i>
<i>Bureau of Public Roads</i> .....	THOMAS H. MACDONALD, <i>Chief.</i>
<i>Bureau of Agricultural Economics</i> .....	NILS A. OLSEN, <i>Chief.</i>
<i>Bureau of Home Economics</i> .....	LOUISE STANLEY, <i>Chief.</i>
<i>Plant Quarantine and Control Administration</i> .....	LEE A. STRONG, <i>Chief.</i>
<i>Grain Futures Administration</i> .....	J. W. T. DUVEL, <i>Chief.</i>
<i>Food, Drug, and Insecticide Administration</i> .....	WALTER G. CAMPBELL, <i>Director of</i> <i>Regulatory Work, in Charge.</i>
<i>Office of Experiment Stations</i> .....	....., <i>Chief.</i>
<i>Office of Cooperative Extension Work</i> .....	C. B. SMITH, <i>Chief.</i>
<i>Library</i> .....	CLARIBEL R. BARNETT, <i>Librarian.</i>

This bulletin is a contribution from

<i>Forest Service</i> .....	R. Y. STUART, <i>Chief.</i>
<i>Branch of Research</i> .....	EARLE H. CLAPP, <i>Assistant For-</i> <i>ester, in Charge.</i>
<i>Forest Products Laboratory</i> .....	CARLILE P. WINSLOW, <i>Director.</i>
<i>Section of Timber Physics</i> .....	ROLF THELEN, <i>in Charge.</i>

**END**