

Staff Papers Series

Staff Paper P89-15

April 1989

IMPLAN MODELING APPLICATIONS IN STATE AND REGIONAL DEVELOPMENT

by

Wilbur Maki, Doug Olson, Scott Lindall, David Senf, and Con Schallau



Department of Agricultural and Applied Economics

University of Minnesota
Institute of Agriculture, Forestry and Home Economics
St. Paul, Minnesota 55108

IMPLAN MODELING APPLICATIONS IN STATE AND REGIONAL DEVELOPMENT

Wilbur Maki, Doug Olson, Scott Lindall, David Senf, and Con Schallau

Staff Papers are published without formal review within the Department of Agricultural and Applied Economics.

The University of Minnesota is committed to the policy that all persons shall have equal access to its programs, facilities, and employment without regard to race, religion, color, sex, national origin, handicap, age, veteran status or sexual orientation.

Contents

	<u>Page</u>
Summary	1
Introduction	1
Model Description	2
Problem Focus	5
Market Analysis	6
Export expansion and import substitution	6
Regional trade balances	8
Regional supply sufficiency	11
Resource Use Analysis	12
Job creation or dislocation	12
Increase growth or decline	13
Resource discovery or depletion	13
Factor and product substitution	14
Strategic Visioning	15
Current situation	15
Community participation	16
Modeling and Data Requirements	16
Cross-sectional studies	16
Longitudinal studies	18
References	19

IMPLAN MODELING APPLICATIONS IN STATE AND REGIONAL DEVELOPMENT

Summary

IMPLAN (Impact analysis for PLANning) is a computer software package and an accompanying highly disaggregated county-level data base. These two IMPLAN features make possible the construction of detailed interindustry and intersector accounts for any county or combination of counties in the US. The computer software can be used also in the construction of input-output tables for regions outside the US.

Choice of the IMPLAN system for modeling applications in state and regional development relates to its salient features. They include:

- o A user-tested software program with a growing record of successful applications in public agency research, planning and management;
- o A built-in data base at a 528-sector level of industry detail that is detailed enough to portray the uniqueness of any county;
- o A comprehensive geographic coverage of 3100 counties in the US that can be combined into multiple county regions so as to correspond with any administrative, planning, or analytical delineations;
- o A detailed coverage of all components of US and regional economic accounts;
- o A menu-driven, user-friendly interface that provides easy access to system modeling capabilities;
- o An adaptable system allowing user-initiated changes of any county data base and its parameters, including changes in trade flows and industry technology.

The IMPLAN county-level data base is developed from a 528-industry US input-output model and a set of state-level and county-level parameters and control totals. Aggregate county-level commodity production and demand requirements are reconciled with US control totals in the National Income and Product Accounts (NIPA). The current IMPLAN system, for example, is based on a 1982 US input-output model and 1982 NIPA control totals for 19 final demand

sectors and five primary input sectors.

IMPLAN applications of input-output modeling in economic development focus on (1) impact studies and (2) analysis and planning. They address research concerns about the economic effects of changes in local economic activity and the measurement and analysis of these effects. They also address management concerns about changing markets and resource supplies and their implications for business and community development.

From a business or community management perspective, improved market access and resource productivity are essential conditions of local economic viability. Most IMPLAN applications are split between these two concerns and between impact studies and planning and analysis.

For the most part IMPLAN applications in market analysis deal with the local effects of changes in export markets or the regional economic base. Their policy or action orientation is one of market expansion. The methodologies used in these studies can also be applied to the study of import substitution and its implications for regional economies.

IMPLAN applications identified with resource use analysis deal with regional economic effects of job and income gains and losses. Economic effects of resource discovery and development or depletion are addressed tangentially in most IMPLAN modeling applications. Issues of factor and product substitution and their social and economic effects, which are central to resource use management, are not addressed.

IMPLAN applications in state and regional development can readily aid in the analysis of alternative community futures. Alternate future scenarios built by community or group participation can be compared to baseline projections. The alternative futures would be presented as departures from the baseline with a yearly social accounting matrix to summarize differences

and implications for the economic well-being of the community region or state.

Modeling and data requirements of the IMPLAN applications are summarized for the two types of studies of regional economic systems--cross-sectional and longitudinal. Of particular importance to these studies are the import and export tables that show the industry destination of commodity disbursements from one region to the rest of nation and vice versa. For longitudinal studies, the interindustry transactions tables would change from year-to-year because of changing patterns of exports and imports, which would change the multiplier values. More importantly, however, the accumulative effects of these changes would differ from their cross-sectional counter-parts. Year-to-year and long-term multiplier differences among local industries result from differing relationships to export market structure and corresponding community economic base.

IMPLAN applications in state and regional development are illustrated by the study of regional trade flows. Such studies may be initiated by a state development agency to provide an information base for export expansion and import substitution programs. A Minnesota trade flow study, for example, requires a detailed industry breakdown of Minnesota commodity exports that are derived from several economic modeling systems. IMPLAN is used to establish a bridge between US foreign exports based on one modeling system and MN foreign exports based on another modeling system. Projected changes in US foreign exports are thus systematically and accurately converted into corresponding changes in Minnesota foreign exports.

IMPLAN MODELING APPLICATIONS IN STATE AND REGIONAL DEVELOPMENT

Wilbur Maki, Doug Olson, Scott Lindall, David Senf, and Con Schallau

IMPLAN (IMpact Analysis for PLANning) is a microcomputer-based system for constructing regional economic accounts and input-output tables. It is currently maintained by the US Forest Service at the Ft. Collins Colorado Computer Center with assistance from the University of Minnesota. It provides software capabilities and a data base for constructing a 528-industry transactions table and related intermediate and final demand, value added, and import and export sectors for any county or combination of counties in the US.

Present IMPLAN users include 10 federal agencies, nine state governments plus the Great Lakes Governors Conference, and 39 public and private universities in 29 states. The wide variety and geographic distribution of IMPLAN users is in part due to its demonstrated values in accurately and comprehensively representing the economic structure and activities of any county or multi-county region. These capabilities are being updated with the construction of 1985 and eventually current year IMPLAN input-output tables.

Economic development applications of IMPLAN modeling in state and regional development focus largely on impact studies, regional economic analysis and planning. Recent applications address research concerns about the economic effects of changes in state and regional economic activity and the measurement and analysis of these effects. They also address management concerns about changing markets and resource uses and their implications for business and community development.

This paper attempts to relate the various IMPLAN applications to the building of an effective and accessible information-yielding capability for education and planning in state and regional development. One important

objective of this effort is an enriched and thorough understanding of the workings of a regional economy among state, regional and community decision makers. Another is having an expanded capacity for preparing scenarios of alternative regional and community futures that have a high authenticity for accurately representing regional and community economic constraints, resources, threats and opportunities.

Model Description

The IMPLAN system includes descriptive accounts of interindustry and intersector transactions among producing and purchasing economic units--business, household and government--in a county or group of counties. Mathematical manipulation of these accounts provides estimates of the employment, output and income changes stemming from changes in product demand, supply-side constraints or industry production, and structural changes in regional economies.

Construction of an IMPLAN data base for a county or region is accomplished in two stages. First, a US input-output model of the sort shown in Figure 1 is prepared for the base year, like 1982. The 528 producing industries in the interindustry transactions table disburse their commodity outputs to 15 final demand sectors, including three household (high, medium and low personal consumption), three business investment sectors (gross private capital formation and inventory sales and inventory purchases), three state and local government sectors (all sales, education purchases and non-education purchases), four federal government sectors (all sales, CCC sales, defense purchases, and non-defense purchases), and two trade sectors (foreign exports and domestic exports). The 528 industries are also represented by their purchases of intermediate and primary inputs and the 15 final demand sectors purchases of primary inputs (as employee compensation, proportional income,

indirect business taxes, and other value added) and intermediate and final products imported from domestic and foreign sources.

Individual county data bases are prepared from the 528-industry breakdown of employment, output per employee and total output. The IMPLAN system provides the software package for constructing the input-output models that structurally correspond with the US input-output tables, as shown in Figure 2.

Individual steps in the derivation of county or multiple county input-output models are shown in Figure 3. The logic flow chart helps organize the making of choices among the many options available in the construction of county or regional interindustry and intersectoral transactions tables. This approach starts with the problem definition, the development of the regional accounts, and, finally, the development of a predictive model. The individual steps lead to the completed table construction for a single county or region.

The latest version of IMPLAN makes possible the construction of "hybrid" accounts based on area-specific and industry-specific information provided by the user. In addition to directly modifying the IMPLAN data base, a user can alter import and export relationships, change production functions, introduce new industries and disaggregate existing ones.

The microcomputer version of IMPLAN has been designed to operate on an IBM compatible personal computer. Specific computer requirements for Micro IMPLAN are MS-DOS 2.0 or higher, 640 KB of random access memory, a math or floating-point coprocessor, and at least 10 MB of disk space.

The MicroIMPLAN version is much improved over its earlier main-frame version (which is no longer available). Complete transaction matrices, including social accounts, are speedily and adequately handled on a PC-compatible personal computer meeting the minimum computer requirements.

Changes in regional variables and relationships are readily introduced into the regional data base. All assumptions are up front and accessible to the user. Additional support via a help line is also available to further reduce user learning time.

One unique feature of IMPLAN is its flexibility. It is used currently in organizing and manipulating data bases for countries and regions with many data limitations, like Mexico. Another unique feature is its capability for constructing complete regional social accounting matrices. The system can also simulate industry output, employment and income effects of a given change in any one or more of a large number of regional export demand and/or supply variables. These effects can be measured from a given historical base year like 1982 or 1985 or a projected year, like 1990 or 2000.

The reality of an impressive learning curve still remains its major disadvantage, which is significantly reduced by attendance at a MicroIMPLAN training session. Another disadvantage of IMPLAN is its static nature. It provides a "snapshot" rather than a "moving picture" of a regional economy. This disadvantage is addressed by the use of a dynamic simulation model, like IPASS (Interactive Policy Analysis Simulation System) to move the IMPLAN data base from one year to the next.

Decision makers use IMPLAN results to assess human and environmental effects of proposed and projected changes in the demand for or the supply of specific commodity outputs. IMPLAN has a unique capacity for relating specific economic and demographic changes to the concerns of local residents as manifested in changing job, income, investment and consumption outlooks. Moreover, IMPLAN can address a wide variety of data base situations, ranging from the most highly to far less developed national and regional settings. Users of IMPLAN and their applications are summarized under three

institutional categories, as follows:

1. Federal and regional agencies: FEMA (recovery planning from hazardous wastes); USBM (Alaska minerals development); NPS, BLM and FS (resource planning; BPA (electrical rate evaluation); ERS (agricultural policy); TVA (recreational development), Corps of Engineers (river basin development); FWS (wildlife refuge establishment); Pacific Marine Fisheries Council (west coast fisheries); FES (community development extension).
2. State and regional agencies: Great Lakes Governors Conference; Michigan; Maryland; Nebraska; Oregon; South Carolina; Tennessee; Illinois; Indiana; Washington.
3. Educational institutions: Alabama; Auburn; California at Berkeley; Chico State; Clemson; Colorado; Colorado State; Dartmouth; Delaware; Florida State; Georgia; Idaho; Illinois; Southern Illinois; Iowa State; Kansas State; Lewis and Clark; Louisiana State; Northeast Louisiana State; Michigan Tech; Michigan State; Minnesota; Missouri; Montana; Nebraska at Omaha; New Mexico State; New Hampshire; Ohio State; Oregon State; Pennsylvania State; South Dakota; Utah State; Virginia (VPI); Washington; Washington State; West Virginia; Wisconsin; Wisconsin at Superior; Wyoming.

While ex post comparisons of simulation accuracy have not yet been made, the use of gross, rather than net, exports and the consequent increase in regional imports, has reduced multiplier values. Also the use of Type III rather than the larger Type II multipliers results in impact values that are closer to the actual change than earlier Type II values based also on the use of net exports and imports. All IMPLAN county data bases are calibrated to US NIPA (national income and product accounts) control totals and individual state REIS income, earnings and employment series.

Problem Focus

From a business or community management perspective, improved market access and resource productivity are essential conditions of local economic viability. They are addressed in IMPLAN-related market and resource use analysis in context of one or more.

Market analysis as a tool of state and regional economic development relates to the determinants of changing demand for the goods and services

produced by economic units in a state or region. It is a macro-to-micro approach to the study of export and local markets.

Resource use analysis often is micro-economic in its approach. It includes the assessment of micro-to-macro effects, for example, the job and income consequences for a state or region of a particular plant closure.

A third management concern not often touched upon by IMPLAN-based studies is the capability of relating short-term changes to long-term consequences. It can be viewed as a form of long-range, or strategic, planning. It involves a process of participatory construction of alternative corporate or community futures--a sort of "strategic visioning."

Market Analysis

For the most part, market analysis using IMPLAN deals with the local effects of a shifting state or regional economic base resulting from changes in export markets. The policy or action orientation is one of market expansion, explicitly final product markets but implicitly, also, intermediate product markets. This distinction becomes important in interdependent regional economic systems. Indeed, every region or community is linked by trade to some other region or community but with varying intensity of interaction depending upon the size of and distance to its nearest neighbor.

Export expansion and import substitution

Growth in regional industry activity, according to export-base theory, is achieved by expanding export markets. Long-term economic well-being is determined by each region's industrial capabilities for exploiting its natural resources or productivity and profitably transforming imports into value-added exports.

The export base of a region is linked typically to the intermediate product markets of large urban centers, especially their manufacturing

sectors. Tourism and recreation activities and transfer payments, on the other hand, relate to final product markets--the shops and services of Main Street merchants.

From an input-output modeling perspective, visitor purchases are not differentiated from those of local residents. A matrix of recreation expenditures by activity can be used, however, to convert final purchaser prices and products into producer prices and commodity outputs. Such a matrix is part of the US Forest Service/University of Minnesota interactive policy analysis simulation system (IPASS) now being used in assessing the impact of tourism/recreation activities in the Southeast Alaska economy and the US Forest Service recreation facility requirements for maintaining and expanding these activities.

Because of low material input requirements natural resource exploitation in itself places few added burdens on imports. However, an increase in value added manufacturing triggers related changes in imports or local production or both. Exports and imports are thus inexorably linked by the production systems they serve.

IMPLAN modeling applications for assessing import substitution opportunities and impacts are essentially the same as those assigned to export expansion. Unless lack of comparative advantage is addressed, however, an import substitution strategy is likely to lack credibility and eventual success.

Existing IMPLAN modeling capabilities can address the comparative advantage issue through the use of cost-sensitive regional purchase coefficients (RPCs). Additional work is still needed in the formulation and estimation of RPC functional relationships (Alward and Despotakis; Siverts).

Economic variables and relationships affecting regional exports and

imports that contribute to the difficulties encountered in measuring changes in regional activity include (1) gross regional commodity demands and (2) regional shares of US domestic and foreign trade flows. Changes in these variables and relationships are associated with corresponding changes that occur in either the levels of both export and imports or in their industry specific relationships. Their importance in affecting regional economic activity can be discussed under two headings--regional trade balances and regional self sufficiency.

Regional trade balances

Individual industry trade balances are calculated for illustrative purposes from the industry origins of foreign and domestic exports from and imports to Minnesota as summarized in Table 1. These trade balances have been compiled into 13 aggregated sectors from the 528-sector Minnesota IMPLAN model (Regional Econometrics, Inc., 1989).

The IMPLAN system has provided both the computer programs and the data base for building a Minnesota trade model as outlined schematically in Figure 4. Choice of the IMPLAN system for modeling applications in state and regional development related to its salient features. They include:

- o A user-tested software program with a long record of successful applications in federal agency resource planning;
- o A built-in data base at a 528-sector level of industry detail;
- o A comprehensive coverage of 3100 counties in the US that can be combined into multiple county regions so as to correspond with any administrative, planning, or analytical delineations;
- o A detailed coverage of all components of US and regional economic (NIPA) accounts;
- o A menu-driven, user-friendly interface that greatly expands access to

its full modeling capabilities;

- o An adaptable system allowing user-initiated changes in an individual county data base and parameters, including changes in trade flows and industry technology.

The accounts and models, which are constructed from data acquired by using a variety of non-survey and occasionally survey techniques, characterize the inter-dependence among producing and consuming sectors of an economy (Alward, 1987).

IMPLAN modeling applications in state and regional development are illustrated by the study of regional trade flows. Such studies may be initiated by a state development agency to provide an information base for export expansion and import substitution programs. The Minnesota trade model, for example, requires a detailed industry breakdown of Minnesota commodity exports that are derived from several economic modeling systems. IMPLAN, with its large number of individual sectors, is used to establish a bridge between US foreign exports based on one modeling system and MN foreign exports based on another modeling system in benchmarking MN trade flows. Projected changes in US foreign exports are thus systematically and accurately converted into corresponding changes in Minnesota foreign exports.

The data base on US and Minnesota export trade can be used in deriving the flow of imports into Minnesota from domestic industries or foreign sources. Sources of excess demand can be identified and the magnitude of the deficit commodity production can be calculated while the existence of the deficit commodity supply is usually traced to lack of comparative advantage in its production.

The tabular presentation for the Minnesota IMPLAN data base shows import purchases originating from industries outside Minnesota exceeding the total

exports of Minnesota goods-producing industries. The positive trade balance of other sectors, including value added transfers to Minnesota from the foreign operations of Minnesota corporations, compensate for the negative goods-producing industry trade balance in 1982--at least enough to yield a positive overall trade balance.

US foreign exports provide another measure of comparison of foreign trade dependency, namely, the percentage of total US foreign trade originating from Minnesota export-producing industry. This share ranged from 0.9 percent of US manufactured nondurables to 5.1 percent of US farm commodities in the 13-industry breakdown. This range is much wider, of course, among the 528 sectors.

The 1982 data show further that foreign imports into Minnesota of nearly \$5 billion in 1982 were almost entirely goods rather than services. Purchases of domestic imports, which were over \$35 billion in 1982, included \$6.2 billion of services.

The 13 Minnesota producing industries purchased nearly 56 percent of the total imports in the form of intermediate rather than final products. The percentage distribution of imports between intermediate demand and final demand sectors varied greatly among the individual commodity groups. These differences correspond, of course, with differences in industry clustering and stages of the production process.

Quarterly and annual estimates of a region's commodity-specific foreign exports are currently available from the US Department of Commerce (USDC, 1988). The US Department of Commerce estimates (USDC, 1984) differ from those based on the 1982 IMPLAN data because of differences in commodity classification and designation of originating state or region. The USDC estimates of exports from Louisiana, for example, include through shipments of

commodity production from other states to final markets outside Louisiana.

Regional supply sufficiency

Total commodity production originating from and received in Minnesota is commonly expressed by two statistical measures of regional self sufficiency--the export market share coefficient and the import dependency coefficient. The market share coefficient is expressed as a ratio of given regional industry exports to corresponding US exports or industry output. It can be viewed as a policy or target parameter among individual businesses. The import dependency coefficient is expressed as a ratio of total import purchases of a given regional industry to total industry purchases. It is a derived value rather than a target parameter. Finally, each of the two ratios is multiplied by its corresponding denominator when forecasting future exports from and imports to a given regional industry.

A third trade strategic concept, and one that is central to the derivation and use of regional purchase coefficients (RPCs) in domestic and foreign trade analysis is the propensity to import--the proportion of a region's total requirements of a given commodity that originates from other regions, including foreign countries. For those commodities produced in excess supply in the region, all requirements are met without imports, except for "cross-hauling". Conversely, for noncompetitive imports, that is, imports of commodities not produced in the region, the import propensity is 1. In Minnesota, commodities originating in the mining industry have a high import propensity while service industry production has a low import propensity. Manufacturing is characterized by low to moderate import propensities.

The import propensity coefficient is derived from the regional purchase coefficient, which is defined by the ratio of net commodity supply to gross regional commodity demand (Stevens, Treyz, Ehrlich, and Bower, 1983). Net

commodity supply is the total amount of a commodity available for consumption in the region, namely, gross commodity production, plus inventory and institutional (state, local and federal government) sales, less foreign exports. Gross regional commodity demand is the sum of regional intermediate demand plus regional final demand.

The import propensity coefficient is defined as $(1-RPC)$. It is a measure of import dependency that includes both intermediate demand and final demand in the denominator. This measure of market share ranged from 1.1 percent of the gross Minnesota commodity demand for wholesale margins to 81.7 percent for manufactured durables. Unlike the export share coefficient, the proportion of US industry gross output accounted for by any one region is generally small because of the wide geographic distribution of import as compared with export origins.

Resource Use Analysis

IMPLAN applications identified with resource use analysis deal with the effects of job and income gains and losses generated by changes in resource use. One topic not often addressed in any of the IMPLAN applications is factor and product substitution. It is discussed here with reference to new developments in extending IMPLAN applications.

Job creation or dislocation

An important IMPLAN modeling capability is the use of a local labor market module for relating industry staffing requirements to the acquisition of new and existing job skills. Both industrial targeting and regional planning studies can use such a capability as they relate to issues of skill acquisition for new entrants into the local work force and, also, for upgrading the currently employed work force.

Job creation strategies also involve facility investments to reduce

capital constraints (Kasal). An investment module would help in the related analysis by quickly and accurately converting the functional categories of producer durable equipment and purchaser prices to corresponding commodity production and producer prices. Such a module would relate to the level of resource use, not necessarily its productivity.

Income growth or decline

Closely related to changes in the labor market are changes in personal, business and government income levels and their distribution by functional category. Shifts in occupational, as well as industry, patterns have lead to strong income growth in metropolitan regions. In Minnesota, for example, earnings per worker are nearly 40 percent higher in the Minneapolis-St. Paul metropolitan core region than in the rest of the state. Even in the same industry, earnings per worker are higher in the Metro Region than in Greater Minnesota. Highly correlated with earnings is investment per worker, which, in turn, depends ultimately on access to information.

Resource discovery or depletion

Economic effects of resource discovery and development or depletion have been addressed in IMPLAN-related modeling applications. For example, in a recent study completed for the US Bureau of Mines, a US Forest Service/University of Minnesota research team used a generic production function approach to introduce new technical coefficients representing different stages in Alaska minerals development (Shantz and Maki, 1987). This method provides for quick access to the assessment of a vast array of entirely new regional minerals development options that are represented by unique sets of industry technical coefficients.

Use of IMPLAN modeling in assessing specific industry as well as economy-wide effects of compensating present resource owners of set-aside

agricultural land in a conservation reserve program is an additional application of conventional impact analysis for resource management purposes. The set-aside programs may create jobs and income in industries other than agriculture, for example, retailing. The tourism-recreation module cited earlier could be used in such studies to assess the local economic effects originating with this program

Factor and product substitution

Factor and product substitutions are central to resource use management in achieving various productivity improvement goals. Whether or not the substitutions are price-induced or technology-induced is not necessarily important to the economic impact assessments, except for the industry-specific changes in input purchases and their effects on local demands for intermediate products and a region's comparative advantage (and thus the future growth of its basic industries). Here, again, quick and easy access to the modeling of RPC changes becomes critical.

Price-induced and technology-induced changes in a regional economic system may occur through the transportation sectors. Existence of high transportation costs for the Southeast Alaska economy, for example, precludes development of a basic manufacturing or service sector, other than one engaged in the exploitation of the region's natural resources. Availability of a transportation module to convert final transportation services and purchaser prices to commodity production and producer prices is important for the further development of input-output modeling applications in the economic development of natural resource-based, peripheral regions.

Other changes in the productivity of human resources may occur through education and training and the cultural values that contribute to a strong work ethic. Industry expansion in Minnesota is attributed in part to the

preception of its high labor productivity.

Strategic Visioning

IMPLAN modeling applications in economic development can hardly preclude the creation of alternative community futures. One test of understanding of regional and community economic systems is to accurately forecast their future over an entire business cycle or more (Schnaars). Sorting out short-term cyclical changes from long-term trends would be an important task of economic analysis in economic development.

Such a forecast starts with the construction of economic base multipliers from the final demand and value added accounts. The export-producing industries become the measure of future threats and opportunities facing a region or community. Most important, however, is the active participation of community members in the preparation of the future scenarios.

Current situation

Extension of sectoral and impact analysis to scenario development would start with a clear and concise representation of the current situation, including:

- o constraints, including industry investment and employment;
- o threats, including both cyclical and structural;
- o resources, represented in part by industry value added;
- o goals, as represented by jobs and income; and
- o opportunities -- new markets and improved productivity.

Threats, goals and opportunities are less readily presented by input-output modeling than constraints and resources, although the complete social accounting matrix (SAM) provides a useful addition to the standard tables for showing the broad range of economic effects associated with each scenario.

Community participation

Community-based scenario preparation typically starts with a baseline projection. Alternative future scenarios differ from the baseline scenario because of differences in (1) industry product mix and market demands for locally-produced commodities and (2) industry input requirements and factor productivity. The alternative futures are presented as departures from the baseline projection with a yearly SAM to summarize these differences and their implications for the economic well-being of the community and the state or region of which it is an integral part.

Strategic visioning has the added burden of easily becoming elitist and academic, but only in the sense that it depends on factual observations of present trends and their driving forces and a critical exploration of corporate or community goals. The IMPLAN system would be available for use as a community resource to assist in the examination of community constraints and resources in the context of community goals and strategies for achieving these goals in existing business and political environments.

Modeling and Data Requirements

Given the many different IMPLAN modeling applications in economic development, the next step is to assess their data requirements. They are presented under two topics--existing IMPLAN modeling for cross-sectional studies of community economic systems and extended IMPLAN modeling for longitudinal studies of regional economic systems. Under each of the two topics we present some of the data challenges facing IMPLAN users and practitioners.

Cross-sectional studies

In most IMPLAN applications, an exogenous change in the demand for locally-available commodity production is introduced. Industry-specific

effects of this change are measured and analyzed. Virtually every data component in the IMPLAN model is potentially of some importance to these applications.

Of particular importance are the commodity import and export tables that show the industry destination of commodity disbursements from one region to the rest of nation and vice versa (del Ninno). For sectoral analysis and industrial targeting, however, the value of the trade flows data would be enhanced by (1) relating the gross trade flows to their transportation requirements and (2) estimating export, rather than import, market shares for allocating excess regional commodity production among regions.

Input-output tables derived from the 1982 IMPLAN system yield estimates of gross domestic exports and imports. These estimates are not necessarily consistent with the modally-differentiated estimates of transportation requirements. For regions like Southeast Alaska, internal inconsistencies between these two sets of estimates invariably call for special data adjustments to account for the uniqueness of regional transportation requirements. Construction of a transportation module that estimates modally-differentiated transportation requirements of commodity trade flows is proposed, therefore, as a worthwhile and feasible extension of existing input-output methodology and application (Westeren, 1987).

Similarly, use of export-share coefficients rather than import-based regional purchase coefficients would facilitate the use of input-output methodology in regional and community scenario construction. Export expansion as an economic development strategy is most readily described by change in export-market shares. It is also the most readily estimated coefficient for a two-region input-output tableau that starts with a base year and a baseline forecast.

With import substitution efforts, the use of import-based coefficients to describe changes in local import requirements is simple and straightforward. On the other hand, the use of import-share coefficients in projecting future trade flows ignores the role of exports as one of the two or three determinants of import requirements (the others being industry location or relocation and factor productivity changes).

Longitudinal studies

Lacking in conventional input-output modeling is a capability for more than a one-period change. Use of input-output models in longitudinal studies calls for some sort of an added dynamic modeling capability like the University of Minnesota/US Forest Service IPASS (Olson, Schallau and Maki, 1984; Olson, Maki and Schallau, 1985; McHugh et al, 1989). For economic development purposes, this capability must include a procedure for introducing new industries or removing existing ones as a consequence of industry location, dislocation and relocation.

A recently completed US Bureau of Mines study of minerals development in Alaska introduced entirely new minerals industries into a regional input-output table by development stage. More than 170 generic production functions were prepared to represent the several stages of minerals development, starting with exploration and continuing with facility construction, operation, and eventual closure. With each stage, several options were available within the environmental and economic constraints under which a given development would occur. The combination of options could be varied to account for the mining methods most suitable for a particular mineral development.

The generic production function methodology devised for the Alaska minerals development studies is readily extended to other areas with a totally

different industry composition. Much similarity exists among industries in the several stages of their product cycles, although individual industries are represented by a unique set of intermediate and primary input requirement.

References

- Alward, G. S. 1985. IMPLAN Version 1.1: Analysis Guide. Land Management Planning Systems Section, US Forest Service, Ft. Collins, CO.
- Alward, G. S. 1987. IMPLAN Version 2.0: Methods Used for Constructing the 1982 Regional Economic Data Base. USDA Forest Service General Technical Report RM-000, OOp. Rocky Mountain Forest and Range Experiment Station, Fort Collins, CO.
- Alward, G. S. and K. Despotakis. 1987. IMPLAN Version 2.0: Data Reduction Methods for Constructing Regional Economic Accounts. USDA Forest Service General Technical Report RM-000, OOp. Rocky Mountain Forest and Range Experiment Station, Fort Collins, CO.
- Del Ninno, C. 1984. A Two-Region Input-Output Model for Minnesota. Plan B paper submitted in partial fulfillment of the requirements of a Master of Science degree in Agricultural and Applied Economics, University of Minnesota.
- Hwang, H.H. and W. R. Maki. 1979. Users' Guide to Minnesota Two-Region Input-Output Model. Staff Paper Series P79-34. Department of Agricultural and Applied Economics, University of Minnesota, St. Paul.
- Kasal, James, Richard Magleby, 1988. Economic Impact Evaluation Using IMPLAN: A Case Study of the Nebraska Panhandle Project. Resources and Technology Division, Economic Research Service, U.S. Department of Agriculture. ERS Staff Report No. AGES870522.
- Maki, Wilbur, Douglas Olson and Con H. Schallau. 1985. A Dynamic Simulation Model for Analyzing the Importance of Forest Resources in Alaska, U.S. Forest Service, Pacific Northwest Forest and Range Experiment Station, Research Note, PNW-432.
- McHugh, Paul, Douglas Olson, Con Schallau, Scott Lindall, Hossein Akhavi pour and Wilbur Maki. 1987. IPASS Data Preparation Manual. U.S. Forest Service, Pacific Northwest Forest and Range Experiment Station, Technical Report PNW- . Portland, Oregon.
- Olson, Douglas, Con Schallau, and Wilbur Maki. 1984. IPASS: An Interactive Policy Analysis Simulation System, Pacific Northwest Forest and Range Experiment Station, General Technical Report, PNW-170.
- Olson, Douglas, C., Wilbur R. Maki and Con H. Schallau. 1985. IPASS Technical Manual, University of Minnesota, Institute of Agriculture, Forestry and Home Economics, St. Paul, Minnesota, P85-30.
- Personick, V. A. 1987. "Projections 2000: Industry Output and Employment

- Through the End of the Century." Monthly Labor Review, September, p.30-45.
- Regional Econometrics, Inc. 1989. Minnesota Trade Model. A Report for the Minnesota Department of Trade and Development. Regional Econometrics, Inc., 1315 5th Street Southeast, Minneapolis, MN.
- Schnaars, Steven, P. 1987. "How to Develop and Use Scenarios", Long Range Planning, Vol. 20, No. 1, pp. 105-114. Great Britain.
- Shantz, Radford and Wilbur Maki. 1987. "Recent Innovations in Regional Impact Analysis by the Bureau of Mines." Paper presented at Western Regional Science Association Annual Meeting, November 13, 1987.
- Siverts, Leif E., 1988. Modeling Regional Economic Change at the County Level: An IMPLAN Application. A Ph.D. Dissertation submitted to Michigan State University in partial fulfillment of the requirements for the degree of Doctor of Philosophy. Department of Forestry.
- Stevens, B. H., G. I. Treyz, D. J. Ehrlich, and J. R. Bower. 1983. "A New Technique for the Construction of Non-Survey Regional Input-Output Models," International Regional Science Review 8: 3: 271-286.
- US Department of Commerce. 1984. State Export Series, International Trade Administration, U.S. Department of Commerce, Bureau of the Census, Washington, D.C.
- US Department of Commerce. 1985. BEA Regional Projections, US Government Printing Office, Washington, D. C.
- US Department of Commerce. 1988. State Export Series Tapes, International Trade Administration, U.S. Department of Commerce, Bureau of the Census, Washington, D.C.
- Western, Knut Ingor. 1987. Impacts on Regional Development from Changes in the Transportation System Analyzed by Input-Output Methods. Unpublished doctoral dissertation, Department of Economics and Management, University of Trondheim, Trondeheim, Norway.

Figure 1. Intersectoral Transfer in U.S. Input-Output Model.

Originating Region and Sector	U.S.		Rest of World Total	Gross Commodity Output
	Intermediate Purchases	Final Purchases		
U.S.:	<u>Account # 2.0, Use Matrix</u>	<u>Region # 1.3 Final Demand</u>	<u>Account # 1.3,</u>	<u>Account # 1.0 Gross Comm. Prod.</u>
	A * A	A * ZA	A * B	AX
Total Intermediate				
Value Added:	<u>Region # 1.3, Total Value Added</u>		0	<u>Region # 1.3 AV</u>
	A * AV	0		
Rest of World:	<u>Account # 8.0, 9.0, and 10.0 Commodity Import (comp & noncomp)</u>			
	B * A	B * ZB	0	BX
Total Intermediate				
Value Added:	0	0	0	
Gross Industry Output	<u>Region # 1.3, Total Output</u>			
	XA	ZA	XB	X

Figure 2. Intersectoral Transfers in Minnesota Input-output Model.

Originating Region and Sector	Minnesota		Rest of Nation		Rest of World Total	Gross Commodity Production Accounts #1.8
	Intermediate Purchases	Final Purchases	Intermediate Purchases	Final Purchases		
Minnesota:	<u>Accounts #2.0, Region #1.3</u>		<u>Accounts #2.0.</u>			<u>Region #1.300 Exports</u>
	A*A	A*ZA	B*A	A*ZB		A*C
Total Intermediate						
Value Added	A*AV	0	0	0	0	<u>Region #1.3 Total Value-A</u> AV
Rest of Nation:	<u>Lister #7.1, Total Domestic</u>		<u>By subtraction Also: MNTRIO</u>			<u>By subtraction</u>
	B*A	B*ZB	B*B	B*ZB	B*C	BX
Total Intermediate						
Value added:	0	0	B*BV	0	0	BV
Rest of World:	<u>Lister #7.1, Total For. Imp.</u>		<u>By subtraction For Imports</u>			
	C*A	C*Z	C*B	C*ZB	0	CX
Total Intermediate						
Value added:	0	0	0	0	0	CV=0
Gross Industry Output	<u>Region #1.2; Total ind. output:</u>		<u>Region #1.30, Final demand</u>		<u>Region #2.00 Foreign exp.</u>	X
	XA	ZA	XB	ZB	XC	

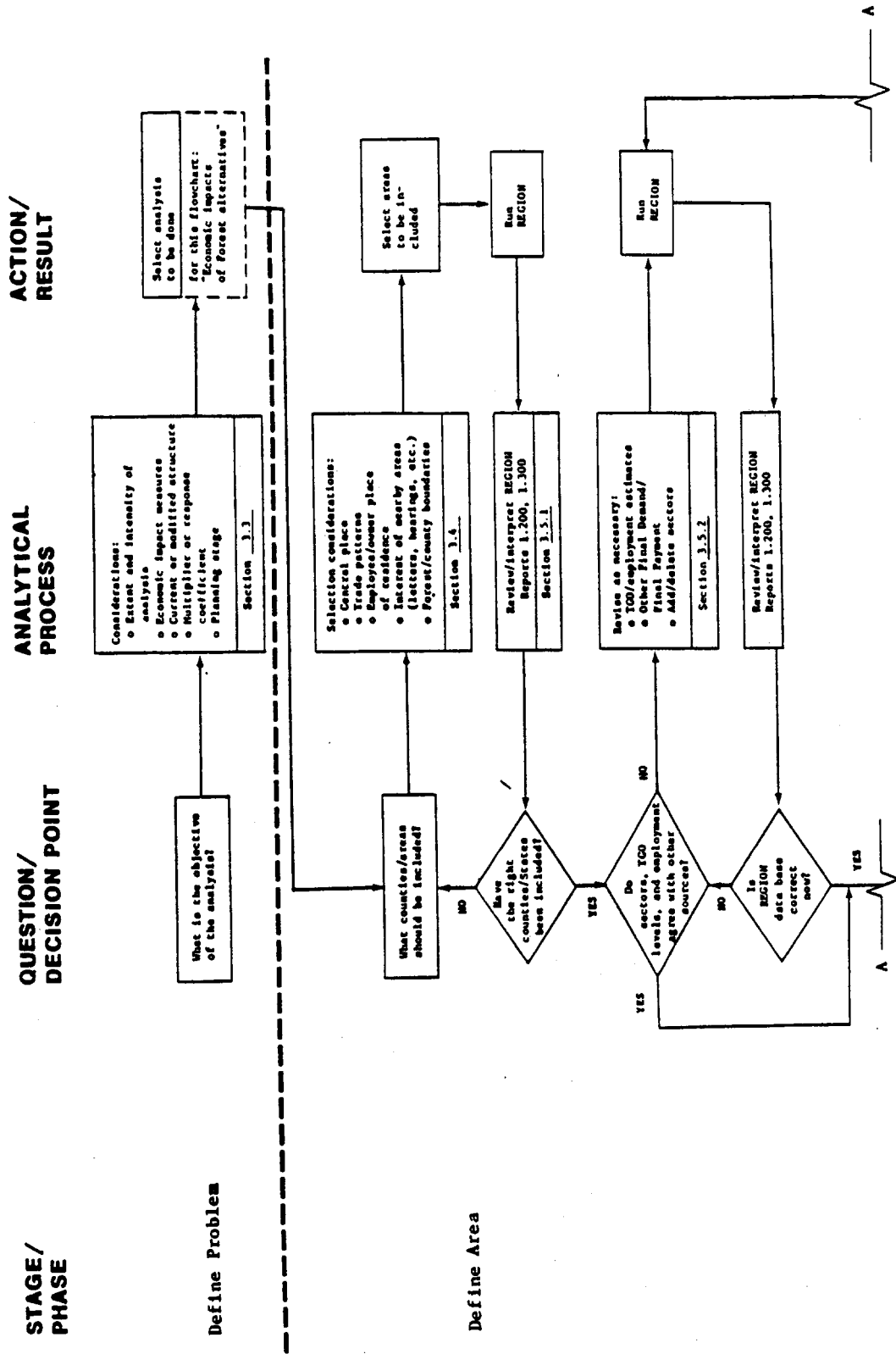

Figure 3-1 IMPLAN Logic Flow Chart

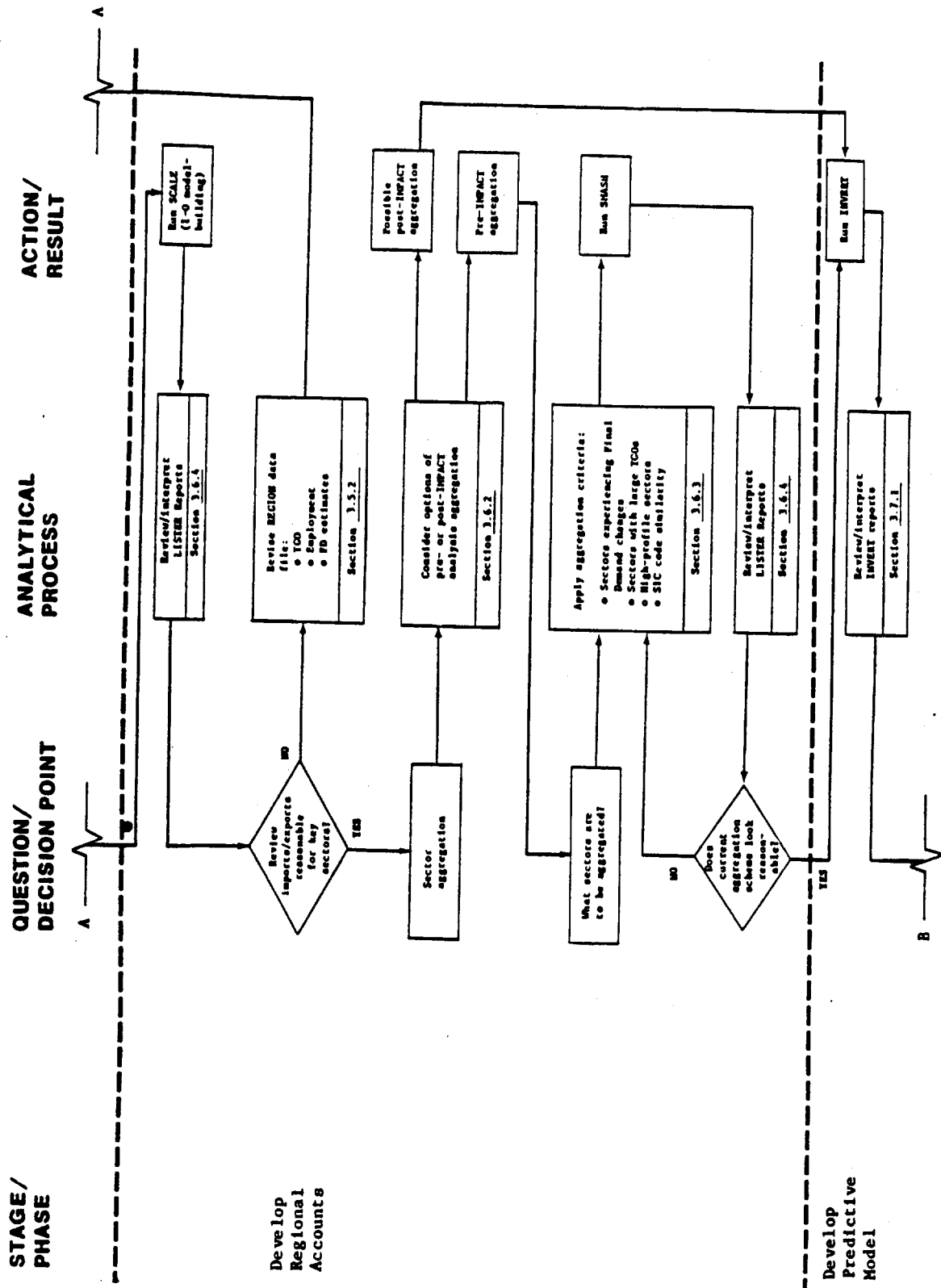

Figure 3-1, cont.

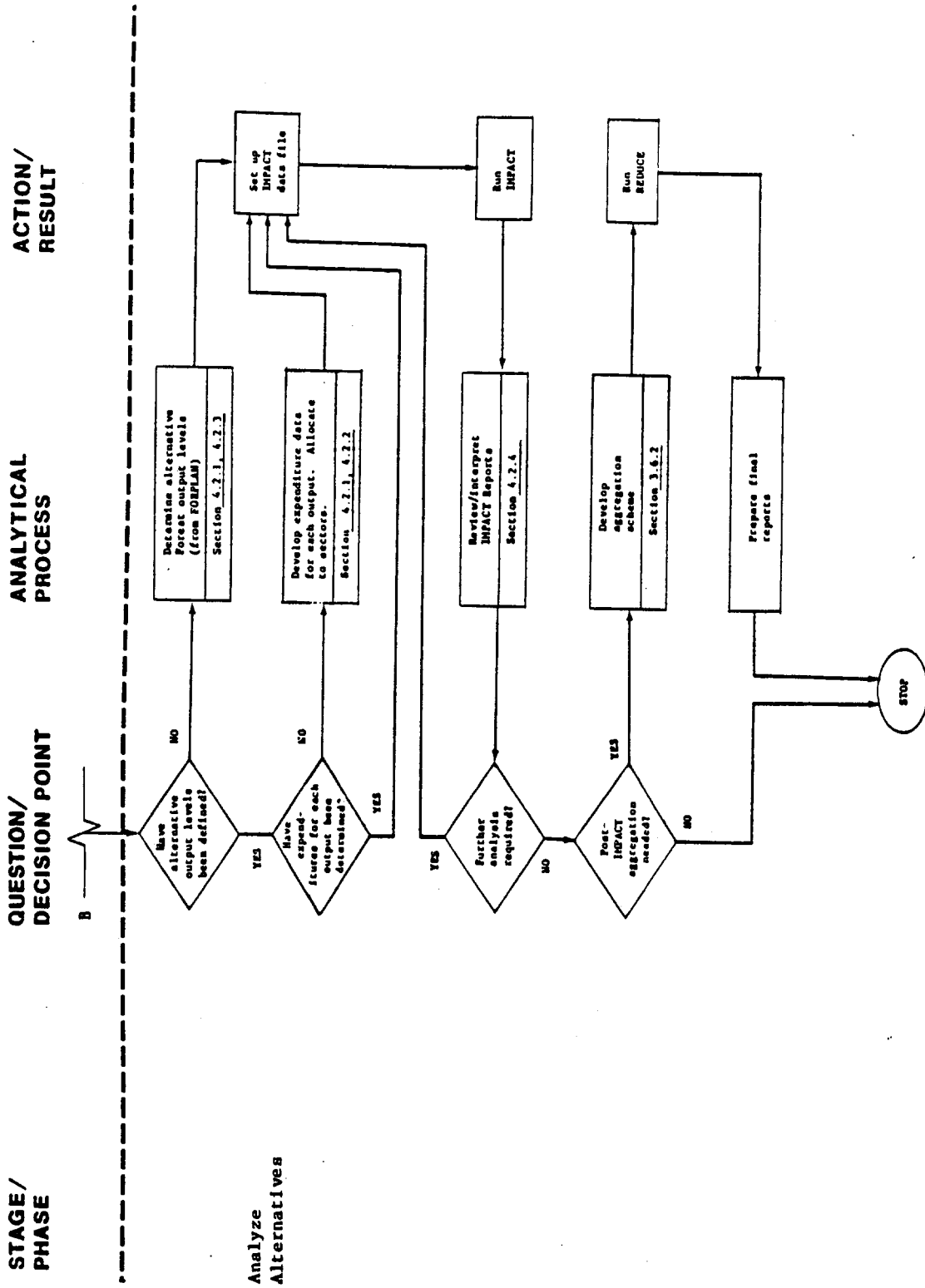

Figure 3-1, cont.

Figure 4. Minnesota Trade Model Structure

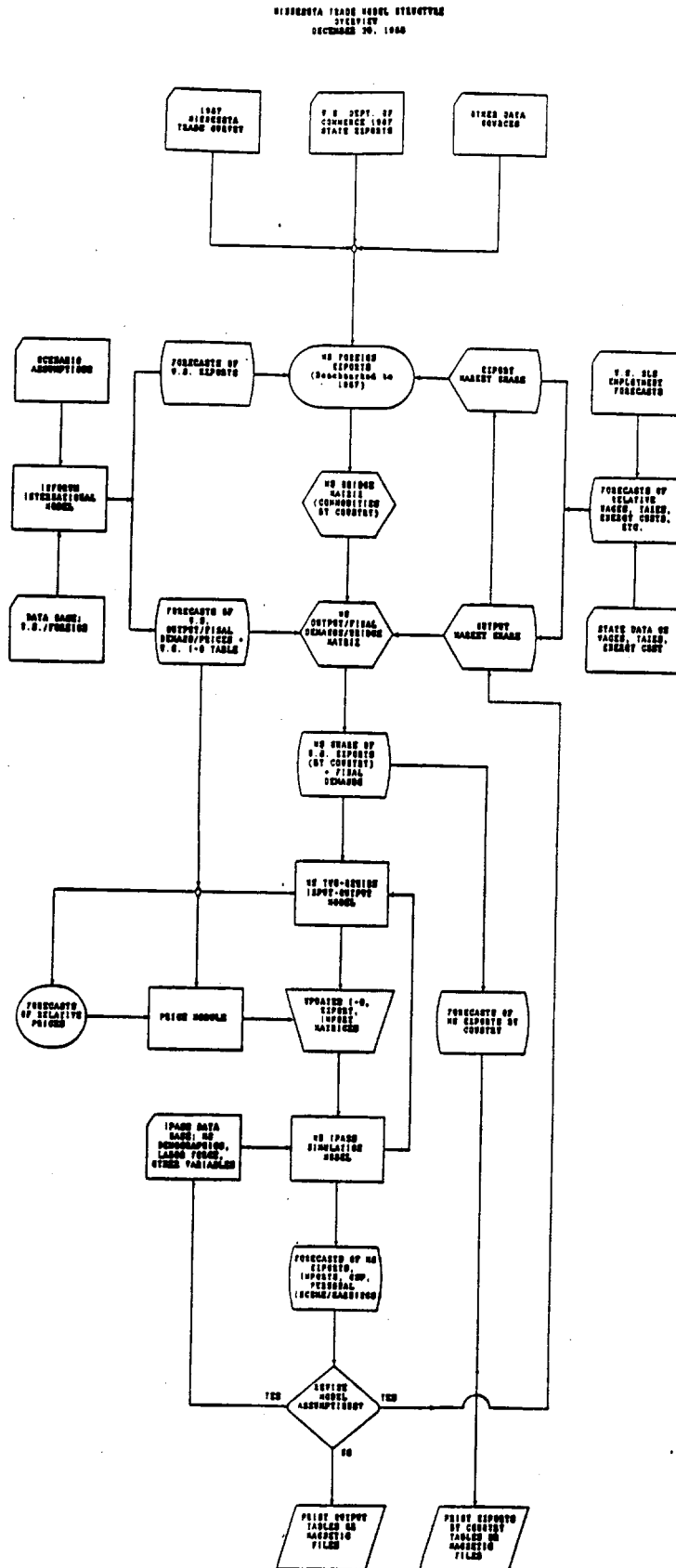

Table 1

Minnesota's foreign market share is the the proportion of US foreign exports originating from Minnesota. In 1982, total foreign exports were \$5.4 billion and total foreign imports were \$2.3 billion. Total domestic exports were \$34.1 billion and total domestic imports were \$35.0 billion. A net trade balance of \$2.2 billion is derived from these data, which show, also, a trade deficit for the goods-producing sectors and a trade surplus for the services-producing sectors.

Producing Sector	Exports			Domestic MN (mil \$)	Imports			Trade Balance			
	Foreign		Share (pct.)		Foreign MN (mil \$)	Domestic		Total Exports (mil \$)	Total Imports (mil \$)	Net Exports (mil \$)	
	US (mil.\$)	MN (mil.\$)				Total (mil \$)	Inter (mil. \$)				Final (mil.\$)
Goods-producing:											
1. Agriculture	18900	958	5.1	2418	51	1992	1666	326	3376	2043	1333
2. Ag. serv.,for.,fis	370	6	1.5	130	20	1092	405	687	135	192	-57
3. Mining	6754	101	1.5	694	493	470	374	96	794	963	-169
4. Construction	42	1	2.1	903	0	1295	296	999	904	1295	-391
5. Mfg., nondurables	58724	538	0.9	9380	977	12139	7433	4686	9918	13116	-3198
6. Mfg., durables	112014	2096	1.9	8410	1735	11771	6361	5410	10506	13506	-3000
Total goods-prod	196804	3709	2.1	21935	3276	18759	16555	12204	25633	31115	-5482
Services producing:											
7. Tran. comm., util.	15908	256	1.6	745	4	1627	1102	525	1001	1631	-630
8. Wholesale trade	18178	375	2.1	829	0	56	53	3	1204	56	1148
9. Retail trade	198	4	1.8	111	0	234	26	208	114	234	-120
10. Fin., ins., real e	6282	103	1.6	2414	0	889	288	601	2517	889	1628
11. Private services	7965	94	1.1	1898	1	2415	1341	1074	1992	2416	-424
12. Government enterpr	280	4	1.3	70	0	57	38	19	74	57	17
13. Other sectors	48333	868	1.8	6140	0	953	0	953	7008	953	6055
Total services-pro	97344	1704	1.8	12207	5	6231	2848	3383	13910	6236	7674
Total	294148	5404	1.9	34142	2281	34990	19403	15587	39543	38271	2192

Table 2

Export and import parameters for individual industries are represented by market share, import dependency, regional purchase, and import propensity coefficients. In 1982, the export market shares of 13 Minnesota industry groups ranged from less than 0.05 percent of US retail industry output to 1.9 percent of US agriculture industry output. The import dependencies of the same industries ranged from no import purchases to import purchases equal to 32.4 percent of total industry purchases, while the net commodity supply ranged from none to 100 percent of gross commodity demand as represented by the regional purchase coefficient (RPC). The import propensity coefficient is then given by the form, $1-RPC$, which shows import propensities ranging from zero propensity for farm commodities to 100 percent for noncomparable imports. Import market share, which is the ratio of total imports to gross regional commodity demand, ranged from 1.1 percent for wholesale trade to 81.7 percent for durable goods manufacturing.

Industry	Industry Output		Export Sales		Import Purchases		Regional Supply Sufficiency		Import Propensity	Import Market Share	
	US (bil.\$)	Minnesota (mil.\$)	Total (mil.\$)	Market Share (pct.)	Total (mil.\$)	Import Dependency (pct.)	Net Supply (mil.\$)	Gross Demand (mil.\$)			Regional Purchase (pct.)
Goods-producing:											
1. Agriculture	175.9	8320	3376	1.9	2101	25.3	7037	6658	100.0	0.0	30.7
2. Ag. serv., for., fi	20.2	185	136	0.7	29	15.7	265	526	50.4	49.6	36.5
3. Mining	196.8	835	788	0.4	233	27.9	759	2378	31.8	69.2	40.5
4. Construction	399.7	7586	904	0.2	2458	32.4	7586	7627	99.5	0.5	17.0
5. Mfg., nondurables	1011.0	18699	9918	1.0	5812	31.1	17654	19866	88.9	11.1	66.0
6. Mfg., durables	941.2	15115	10494	1.1	4523	29.9	13194	16534	79.8	20.2	81.7
Total goods-prod	2744.8	50740	25615	0.9	15156	29.9	46495	53589	86.8	13.2	59.8
Services producing:											
7. Tran. comm., util.	541.6	8715	1001	0.2	2021	23.2	8380	9075	92.3	7.7	18.0
8. Wholesale trade	299.2	6167	1204	0.4	416	6.7	5813	4992	100.0	0.0	1.1
9. Retail trade	427.1	7810	114	0.0	730	9.3	5029	5249	95.8	4.2	4.5
10. Fin., ins., real	719.7	15357	2517	0.4	599	3.9	15312	13787	100.0	0.0	6.4
11. Private services	815.2	14171	1992	0.2	1679	11.8	18259	18672	97.8	2.2	12.9
12. Government enterpr	58.5	918	74	0.1	71	7.7	564	551	100.0	0.0	10.7
13. Other sectors	367.4	7159	7008	1.9	0	0.0	6545	412	100.0	0.0	n.a.
Total services	3226.7	60298	12207	0.4	5518	9.2	59902	52738	100.0	0.0	11.8
Total	5971.5	111038	39607	0.7	20674	18.6	106397	106327	100.0	0.0	36.0